

UNCLASSIFIED

AD NUMBER

AD000211

CLASSIFICATION CHANGES

TO: unclassified

FROM: secret

LIMITATION CHANGES

TO:
Approved for public release, distribution unlimited

FROM:
Distribution authorized to U.S. Gov't. agencies and their contractors; Administrative/Operational Use; 30 NOV 1952. Other requests shall be referred to Air Force Cambridge Research Laboratories, Hanscom AFB, MA.

AUTHORITY

AFCRL ltr dtd 30 Apr 1968; AFCRL ltr dtd 30 Apr 1968

THIS PAGE IS UNCLASSIFIED

Reproduced by

Armed Services Technical Information Agency
DOCUMENT SERVICE CENTER

KNOTT BUILDING, DAYTON, 2, OHIO

AD -

2 1 1

SECRET

SECRET

Copy No. 45

QUARTERLY PROGRESS REPORT NO. 4

Contract No. AF 19(122)-7, Item II

September 1, 1952 to November 30, 1952

Reliability Research

Prepared by

H. L. Stubbs
H. L. Stubbs
Assistant Professor

J. S. Rochefort
J. S. Rochefort
Assistant Professor

L. J. Nardone
L. J. Nardone
Research Associate

W. H. Lob
W. H. Lob
Research Associate

J. Wiren
J. Wiren
Research Associate

M. L. Bovarnick
M. L. Bovarnick
Research Associate

M. W. Essigmann
M. W. Essigmann
Associate Professor
Coordinator

This document contains information affecting the national defense of the United States within the meaning of Espionage Laws, Title 18, U.S.C., Sections 793 and 794. Its transmission or the revelation of its contents in any manner to an unauthorized person is prohibited by law.

SECRET

W-6731

SECRET

TABLE OF CONTENTS

	Pg.
ABSTRACT -----	1
MAIN BODY OF REPORT	
Personnel and Administration -----	2
Communications -----	2
Statement of the Problem -----	3
Methods of Attack	
System Reliability	
General Considerations -----	4
Filtering -----	6
Pulse-Train Correlator -----	9
Behavior of Pulse-Train Correlator in Presence of Noise -----	12
Reliability as a Function of Frequency -----	14
Equipment Reliability	
Transistor Testing -----	16
Apparatus and Equipment	
Pulse-Train Correlator Working Model -----	17
Pulse-Train Generator -----	19
Pulse-Jamming Generator -----	20
Transistor Testing -----	21
Conclusions and Recommendations -----	21
Future Work -----	22
APPENDIX	
Curves and Drawings -----	24
Bibliography -----	44

SECRET

SECRET

-1-

RELIABILITY RESEARCH

ABSTRACT

Included herein are reports of progress made on the various topics under active study during the period from September 1, 1952 to November 15, 1952.

Discussion is given of some methods of optimum filtering that may be applicable in the i-f section of an IFF receiver. An interim report on a survey made to evaluate the usability of s and x-band frequencies for the IFF transmission is given. Further developments are reported on the design and analysis of a pulse-train correlator. A pulse-train generator and a jamming-pulse generator have been completed, and complete details are given. A transistor-testing program has been started, and descriptions of the equipment and procedures employed are included.

SECRET

a. Personnel and Administration

1. Martin W. Essigmann, Coordinator (half time, engineer)
2. George E. Pihl (one-tenth time, engineer)
3. John S. Rochefort, liaison man (full time, engineer)
4. Harold L. Stubbs (half time, mathematician)
5. Walter H. Lob (full time, physicist)
6. Myron L. Bovarnick (full time, engineer)
7. Louis J. Nardone (full time, engineer)
8. Jacob Wiren (four-fifths time, engineer from September 15, 1952)
9. Walter Goddard (one-tenth time, technician)
10. Mary D. Reynolds (half time, secretary)
11. Charles U. Knowles (full-time cooperative student assistant from September 23, 1952 through November 14, 1952; half-time from November 17, 1952)
12. Robert H. Lawson (full-time cooperative student assistant from October 21, 1952 through November 14, 1952)
13. Lawrence J. O'Connor (full-time cooperative student assistant from November 17, 1952)
14. John J. Kelly (full-time cooperative student assistant from November 17, 1952)

The staff assigned to this item of work under the contract was increased during this report period by the addition of Jacob Wiren and two pairs of cooperative student assistants. Wiren has been continuously employed on work under this contract since its establishment at Northeastern, his previous work being under Item I. In his present assignment, he devotes four-fifths time to the transistor testing program, and one-fifth time to work under Item I. His rank at Northeastern is that of Research Associate.

Modification No. 10 to the contract was executed during this period. This modification adds funds and extends the termination date until November 30, 1953. In addition, it provides for an Item 3 to cover work on coding circuitry and transistors as applied to IFF.

b. Communications1. Correspondence

Listings of all non-expendable property received for use under this contract have been sent to the Research Accountable Property Officer under the dates of August 31, 1952, September 30, 1952, and October 31, 1952.

2. Conferences

September 15, 1952. Conference at AFCRC among C. Hobbs, C. Ryan and W. Bishop of AFCRC; and M. Essigmann, W. Lob, H. Stubbs and J. Rochefort of Northeastern.

The purpose of this conference was to discuss Quarterly Progress Report No. 3, and to plan for the introduction of transistor testing into the program of research under the contract.

October 14, 1952. Conference at AFCRC among C. Hobbs, W. Bishop and B. Mills of AFCRC; and M. Essigmann, J. Rochefort and W. Lob of Northeastern.

The purpose of this conference was to inform the AFCRC representatives concerning the work performed at Northeastern directed particularly toward the improvement of reliability of IFF systems by optimum receiver design.

November 12 and 13, 1952. Visits made to the Meteorology Department at M.I.T. by H. L. Stubbs and M. L. Bovarnick. The purpose of these visits was to obtain information regarding such items as expected amounts of rainfall and radar attenuation insofar as these topics are important to transmission reliability. M.I.T. staff members consulted included Dr. J. Johnson, Dr. R. Wexler, and Mrs. P. M. Austen.

J. S. Rochefort, as liaison man between AFCRC and Northeastern, has kept in constant contact with AFCRC to fulfill this obligation. In addition, J. Wiren and C.U. Knowles have made considerable use of the AFCRC facilities in connection with the transistor-testing program undertaken during this report period.

c. Statement of the Problem

This item of the contract is concerned with the study of the communication aspects of the IFF problem with the aim to determine methods for improving the performance reliability of IFF systems. The specific system assumed for the present studies is one in which an n-digit binary number is transmitted as a challenge over a single channel to a transponder where the channel is encoded into an r-digit reply. The reply is transmitted to the responsor, also over a single channel, where it is compared with a locally encoded version to determine whether or not it is correct.

The present studies are concerned with methods for improving the transmission reliability of the ground-to-air and air-to-ground links of the assumed system. These two links differ in that the correct reply is available at the terminal of the air-to-ground link, thus providing the possibility of applying prevalent cross-correlation techniques in the reception of the coded reply. Less powerful means must be resorted to at the airplane since no a priori knowledge as to the challenge can be assumed. Atmospheric, enemy noise and pulse jamming, and enemy attempts at interrogation are being considered as factors which need to be combatted in devising systems to provide improved transmission reliability.

The aspect of cryptographic security introduced by the presence of two encoders in the general system is not a part of the present problem. The system is assumed to be secure against an enemy who can only listen.

d. Methods of Attack

During the first report period the problem of reliability was divided into two parts which were named system reliability and equipment reliability. System reliability refers to the performance of the system if all equipment

operates perfectly, and equipment reliability refers to the performance of the equipment alone. Until the present report period, only the former has been considered since it was felt that techniques for obtaining the maximum system reliability should be investigated first. During the present report period investigation of equipment reliability was initiated with the introduction of a transistor test program.

System Reliability

General Considerations

In approaching the problem of system reliability, the first step was to enumerate the factors which might reduce reliability. They include "atmospherics" and receiver noise, inadequate space resolution, garbling and fruit, as well as jamming and deception on the part of the enemy. Since it appears that interference by the enemy constitutes the major threat to reliable operation, it has been given the most attention in the work done thus far.

The effects of enemy interference by means of noise or pulse jamming can be minimized by either minimizing the possibility that signal and jam will arrive simultaneously at a receiver, or by incorporating equipment in the receiver for improving signal detection in the presence of jamming. The possibility of simultaneous reception of signal and jam can be reduced by directional communication equipment, while signal detection in the presence of jamming can be improved by redundancy coding, filtering, and correlation detection.

Directional communication could be achieved if airplanes as well as ground stations were equipped with narrow-beam antennae. For certain applications (ADC for example) it has been suggested that airplanes could be required to approach interrogators along certain prescribed courses. A narrow-beam antenna mounted in the nose of an airplane would be sufficient and enemy jamming could only be effective if the jammer were within the beam angle of either ground station or airplane.

A general-purpose directional communication system would require a narrow-beam rotating antenna on the airplane. This system has been discussed in detail in a previous report* and the antenna development problem is currently being evaluated by the Antenna Laboratory of AFCRC.

Weight and size considerations would probably make an X-band system mandatory for any directional-communication system. Consequently a survey is in progress in order to obtain factual data so that a comparison can be made between S and X-band frequencies.

Several methods which fall under the heading of redundancy coding have been considered for combatting jamming. They include transmission of a number and its complement, the use of additional digits for error detection

* Quarterly Progress Report No. 2 dated May 31, 1952.

SECRET

-5-

and correction, restriction to a specific number of pulses in the pulse train, and coding to match the channel capacity as defined by Shannon.

Cross-correlation of pulse trains by a process discussed below has been shown to provide an effective means of overcoming the effects of jamming. This method can very well be used at the ground station of a ground-to-air IFF system, since the correct reply is available there. It has been shown that cross-correlation may also be used at the airplane if challenges are transmitted in a pre-arranged sequence which can be duplicated at the airplane with the aid of certain stored information. This system requires two stages of synchronization, the coarser to be achieved with a mechanical clock and the finer by a crystal-controlled or tuning-fork-controlled oscillator.

Optimum filters which sacrifice signal shape and merely indicate when the signal occurs have been shown to be equivalent to cross-correlation. In the presence of noise jamming, the transfer characteristic of such a filter should be the conjugate of the Fourier transform of the signal waveform. The maximum improvement in signal-to-noise ratio is obtained only when a different filter is available at the receiver to match every possible pulse train. However, since storage at the airplane is undesirable, some improvement in signal-to-noise ratio can be obtained if only one filter is used to evaluate each pulse in the pulse train individually. Such a filter would be matched to a single pulse and has been shown to improve the signal-to-noise power ratio by a factor of about 3 over conventional filtering. Consequently optimum filters of this type would be an asset at both the airplane and the ground station.

When applying the above result in the design of a receiver, it appears that the proper place to make use of the optimum-filter technique is the i-f amplifier. Since the second detector is inherently a non-linear device, there is considerable doubt that small signals can be recovered reliably from noise by any post-detection means if the signal-to-noise ratio is less than one at the input to the second detector. Consequently it appears best (pending more complete data concerning the effect of detectors on the S/N ratio) to maximize the signal-to-noise ratio before detection. The test program which is now in the developmental stage has been accordingly enlarged to allow for predetection filtering.

The block diagram of the proposed test set-up is shown in Fig. 1.* The test equipment can be used to simulate either the ground-to-air or air-to-ground link of an IFF system working in the presence of pulse jamming, noise-modulated carrier jamming, and broad-band noise jamming. Figure 1 illustrates the use of the test equipment to simulate the ground-to-air link of the IFF system under study.

The signal generator can be used to generate either the challenge or the reply. The adder used to combine the signal with the three types of jamming is used to simulate the transmission link. Three separate modulators are

* The figures are included in the Appendix.

SECRET

used in conjunction with the signal generator, jamming-pulse generator, and noise modulator, in order to insure that phase agreement does not exist between the three carriers. The high-frequency noise source is used to simulate noise jamming by a travelling-wave tube or some similar device.

The optimum filter can be considered to represent the i-f section of the receiver. A conventional i-f strip or an optimum filter of the type discussed below can be used at this point. The purpose of the optimum-filter study is to attempt to improve the signal-to-noise ratio before detection and thus reduce the low-signal masking effect of noise during detection.

If the air-to-ground link is to be studied, the correlator described in a subsequent section can be used to follow the detector.

Filtering

In the IFF system under study, both challenges and replies are binary numbers which are represented by pulse trains. The presence of a pulse in any digit position is used to represent a one, while a zero is represented by the absence of a pulse.

In the presence of noise or jamming, cross-correlation provides the optimum means of detecting a given challenge or reply. By the very nature of the process involved, however, cross-correlation requires an a priori knowledge of the pulse-train transmitted. Since it is not desirable to store challenges at the airplane, cross-correlation of the entire pulse-train cannot be accomplished at the transponder. However, since the challenge is known to consist of pulses, cross-correlation can be performed on a digit-by-digit basis. As such the correlator cannot be used to determine if the "correct" pulse train has been received, but rather its output can be used to determine which digit positions contained pulses. Consequently this type of correlation would be of little use in overcoming the effects of pulse jamming since a jamming pulse which was similar in shape to a signal pulse and occurred at a zero-digit would be considered to be a signal pulse. However, digit-by-digit correlation would be an effective means of improving signal detection in the presence of noise or noise jamming.

Previously it was shown that cross-correlation could be accomplished by filtering. The optimum filter for this purpose is that filter which has an impulse response, $h(t)$, equal to $s(-t)$, where $s(t)$ is the signal to be correlated. If digit-by-digit correlation is desired, the pulse used to represent a one should be defined as the signal, and consequently the impulse response of the optimum filter should look like the backwards version of the pulse. When the signal is a rectangular pulse such a filter has been shown to improve the signal-to-noise power ratio by a factor of about three over that for a conventional low-pass filter.

The design of an optimum filter appears to be a difficult one if synthesis is attempted on a frequency-response basis. However, if

SECRET

-7-

synthesis is carried out on an impulse-response basis this type of filter can be very nearly approximated by a tapped delay line, weighting networks, and an adding circuit.

If a signal $s(t)$ which is immersed in a noise $n(t)$ is applied to a filter having an impulse response $h(t)$, then the filter output $y(t)$ is given by the convolution integral

$$y(t) = \int_0^t [s(t-x) + n(t-x)] h(x) dx$$

The optimum filter for cross-correlation is that filter which has an impulse response which is the backwards version of the signal. If the signal is of finite duration such that

$$s(t) = \begin{cases} s(t) & \text{for } 0 < t < \delta \\ 0 & \text{for all other } t \end{cases}$$

then the impulse response of the optimum filter becomes

$$h(t) = \begin{cases} s(\delta-t) & \text{for } 0 < t < \delta \\ 0 & \text{for all other } t. \end{cases}$$

Making the above substitution we obtain

$$y(t) = \int_0^{\min\{t, \delta\}} [s(t-x) + n(t-x)] s(\delta-x) dx$$

The above integral may now be approximated by the summation

$$y(t) = \Delta x \sum_{j=0}^m [s(t-x_j) + n(t-x_j)] s(\delta-x_j) \quad \text{where } x_m \leq \min\{t, \delta\}$$

Since $x_0 = 0$, $x_1 = \Delta x$, $x_2 = 2 \Delta x$, $x_m = m \Delta x$, we may rewrite the above expression as

$$y(t) = \Delta x \sum_{j=0}^m [s(t-j\Delta x) + n(t-j\Delta x)] s(\delta-j\Delta x)$$

$$\text{where } m\Delta x \leq \min\{t, \delta\} < (m+1)\Delta x$$

The above expression may now be interpreted in terms of a tapped delay line, weighting networks, and an adding circuit, as is shown in Fig. 2. Since the signal $s(t)$ has a duration δ , the total length of the delay line should be equal to δ . The delay line should be divided into

SECRET

$k = \frac{\delta}{\Delta x}$ sections, and each section should delay the signal by an amount $\tau = \Delta x$. Resistive weighting networks can be used at each tap and should be such that $\omega_j = A(\delta - j\tau)$. The output signal is taken from the adding bus and is equal to $\frac{y(x)}{\Delta x}$.

The circuit indicated by the block diagram of Fig. 2 is not new. It has been used in time-division multiplexing^{1,2*}, in the synthesis of a prescribed transient response^{3,4}, and to obtain a prescribed impulse response⁵. In this particular application it is used to synthesize an impulse response which is the backwards version of the signal $s(t)$. If a unit impulse is applied to the network shown in Fig. 2, the output will consist of a train of $(k + 1)$ equally spaced unit impulses whose amplitudes are attenuated in accordance with the weighting functions. The envelope of the output will be the backwards version of the signal $s(t)$.

Because of the non-linear action of the second detector it appears best to employ optimum filtering before detection as is shown in Fig. 1. Consequently the signal would be a pulse at the intermediate frequency. If the pulse shape was rectangular and the pulse width was equal to some integral multiple of the period of the intermediate frequency, the signal would consist of an integer number, N , of cycles at the intermediate frequency. The interval between taps on the delay line would then have to be small enough to provide a reasonable number of taps during each cycle of the i - f carrier. If ten taps were provided per cycle and the pulse had a duration of 20 cycles, then a delay line with 200 taps would be necessary. This would indeed be a difficult goal to achieve.

However, the above filter could be further approximated if merely one or two taps per cycle were employed. This approximation would simplify the construction problem and give some improvement in signal-to-noise ratio. It would not be the optimum filter, however, and would react equally well to harmonics of the intermediate frequency. Nevertheless this approximation warrants further investigation and may prove to be acceptable.

If the optimum filter were constructed in the form shown in Fig. 2, the design of a delay line with 200 taps might well prove to be an impossible task. However, the same filter can be constructed in different form for the signal described above.

Consider the network indicated by the block diagram of Fig. 3A. The delay line is considered to be lossless and provides an overall delay, (δ/N) , equal to one cycle of the intermediate frequency. The taps are weighted in accordance with the backwards version of one cycle, and about ten taps are provided. Positive feedback with a gain of A is provided.

If $0 < A < 1$, the envelope of the impulse response resembles a damped sinusoid. As such the device is analogous to a band-pass filter.

* Superscripts refer to numbered references given in the bibliography.

If $A = 1$, the network acts as an ideal, lossless filter tuned to a frequency of N/δ . The envelope of the impulse response is a sinusoid which lasts forever. The impulse response differs from that of the desired filter in that it continues after $t = \delta$. This difference can be removed, however, by the network shown in Fig. 3B.

The optimum filter shown in Fig. 3B has an identical impulse response with the one described above for $0 < t < \delta$. At $t = \delta$, the original unit impulse emerges from the additional delay line (delay = δ), is inverted, and cancels the impulse which has cycled N times through the tapped delay line. Consequently the impulse response is the desired one. At the expense of an additional delay line, the number of taps have been reduced by a factor of $1/N$. This model of the optimum filter may prove to be a more practical one to build than one of the type shown in Fig. 2.

At this point the similarity between the pulse-train correlator discussed in the next section and the optimum filter can be clarified. The pulse-train correlator is an approximation of an optimum filter with one tap provided at each digit position. Since the correlator is to be used to detect replies, an a priori knowledge is available, and each tap can be weighted in accordance with the expected pulse train. Since only one tap per pulse is provided, the pulse-train correlator is insensitive to pulse shape or pulse width. This fact is desirable since the filter of Fig. 3B, will convert rectangular pulses into triangular pulses of twice the original width. Consequently the optimum filter shown in the block diagram of Fig. 1 serves a dual purpose. It improves the signal-to-noise ratio in the presence of noise jamming, and discriminates against jamming pulses which do not resemble signal pulses. The pulse-train correlator, on the other hand, gives further improvement in the signal-to-noise ratio and discriminates against incorrect pulse trains.

Pulse-Train Correlator

In this report period the theoretical work concerning the pulse-train correlator was furthered, and the detail design of a working model was completed.

The function of the correlator is basically to produce an output upon reception at one of its two inputs of a probably "correct" pulse train, and to yield no output in the absence of such a pulse train, all in the presence of noise and/or pulse jamming. Here by a "correct" pulse train is meant a pulse train whose pulse and gap assignment has been supplied to, and stored in, the correlator via the other input at some previous time.

The comparison of the stored pulse train $f_1(i)$ and the received one $f_2(i)$ (i being the place number in the train, running from 1 to n for an n -place pulse train) is to be achieved by correlation, i.e. by evaluating

with an analogue computer the value of $\phi = \sum_{i=1}^n f_1(i) f_2(i)$. Roughly

speaking, the greater the value of ϕ the greater is the probability that the correct pulse train was received. A threshold device is to be

provided to produce an output whenever ϕ exceeds a threshold value, the magnitude of which has to be varied automatically to give the best possible results under various conditions of signal strength, jam, etc.

The block diagram for the proposed correlator is shown in Fig. 4. The received video signal is fed into a tapped delay line, the n taps being arranged such that when the last place of a correct n -place pulse train is just entering the line all the other places are at their proper taps. At that instant, therefore, the signal which was received in time sequence, exists in space sequence along the line. Proper staggering of the intervals between places (and of the spacings between taps) will prevent multiple coincidences of places and taps prior to and subsequent to that instant.

Preset toggle switches feed the signal directly to an adding bus at those taps where a pulse is expected (the " m " taps), and feed the inverted signal to the adding bus at the taps where a gap is expected (the " k " taps). Independent of the adding bus, a "threshold" voltage is generated by a combination of the maximum and minimum instantaneous voltages existing at the taps. A threshold device then yields an output whenever the adding bus signal exceeds the threshold voltage.

In the development of a new formula for the threshold voltage the major emphasis was placed on the importance of combatting pulse jamming. Stating this problem more precisely, the probability of obtaining an output when, in addition to pulse jam, there is a "correct" pulse-train present should be maximized, without allowing an output due to the pulse jam in the absence of a "correct" pulse train. (The obvious exception to this latter clause is the case where jam pulses happen to occur at all of the " m " places and at none of the " k " places, thus making the jam indistinguishable from a "correct" pulse train. This exception, however, is the only one that is tolerated.)

These requirements suggest the desirability of a positive contribution to the threshold voltage proportional to the height J of the jam pulses, and of a negative contribution proportional to the height S of the signal pulses, so that jam alone will raise the threshold enough to prevent an output from the threshold device but that the addition of a sufficient amount of "correct" signal will bring the threshold back down enough to allow an output to occur. In symbols we have, then: $V_T = AJ - BS$, where A and B are positive parameters yet to be determined.

In order to carry out such a scheme it is necessary to obtain reasonably reliable estimates of the magnitudes of S and J from the existing video signal. How this can be accomplished using minimum and maximum tap voltages can be seen from the diagrams in Table I, wherein the variables M and K represent the number of " m " and " k " taps respectively at which at a given instant a jam pulse exists, so that $M = 0$ means that there is no jam pulse at any of the " m " taps, $0 < M < m$ means that there are one or more jam pulses at some (but not all) of the " m " taps, and $M = m$ that there are jam pulses at all of the " m " taps. (Similarly with $K = 0$, $0 < K < k$, $K = k$.) It can now be seen that, except in the top row of the table, J can be described as the maximum signal existing at any one of the " k " taps (this value will be represented by the symbol k_{max}), whereas in the top row

(except in the first box where no jam exists, and in the last box where the jam is indistinguishable from the signal), J can be represented by $E_{\max} - E_{\min}$. Since it is considered more important to prevent erroneous outputs from the threshold device than to prevent the occasional loss of correct pulse trains (since, in other words, in the interest of safety, the threshold should be set too high rather than too low), the best estimate of J is the greater one of the two expressions given above, or, symbolically: $\max\{k_{\max}, E_{\max} - E_{\min}\}$

Referring again to Table I, S is equal to E_{\min} everywhere but in the last column, where, however, S can be represented by $E_{\max} - k_{\max}$ (except again in the highest box which need not be considered). Bearing in mind that S is to yield a negative contribution to the threshold, the "safe" estimate for S is: $\min\{E_{\min}, E_{\max} - k_{\max}\}$. We therefore arrive at the formula for the threshold voltage:

$$V_T = A \max\{k_{\max}, E_{\max} - E_{\min}\} - B \min\{E_{\min}, E_{\max} - k_{\max}\}$$

A condition on the value of A in this expression can be found by considering the case where a "correct" signal is absent and a pulse jam is introduced which differs from the "correct" signal in only one place, giving rise to an adding bus signal of intensity $(m - 1)J$, and a threshold voltage AJ . (The two possibilities are shown below.)

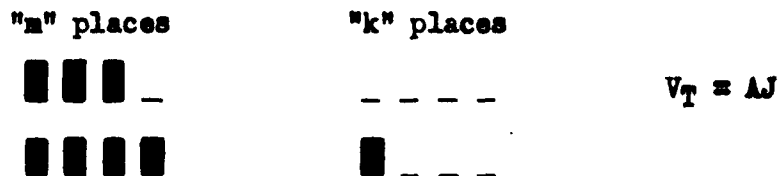

Since no output is allowed in this case, A must be greater than $m - 1$, or $A = m - 1 + \alpha$ where α is a positive constant. This condition on A makes it seem desirable to use a fixed value of m , i.e. to specify that always the same number of places of the pulse train shall be occupied by pulses.

It is expected that the optimum values of α and B will depend on the amount of noise present in the video signal. In the absence of all noise a value of α almost equal to zero and a very large value of B would give very good resistance to constant amplitude pulse jamming. Conditions on the choice of B (and α) required to combat noise and noise-jamming can in principle be determined by calculating the probability distribution for V_x (the adding-bus voltage) and V_T for assumed probability distributions of the noise. Since this calculation, as discussed below under "Behavior of Pulse-Train Correlator in Presence of Noise" appears to be too complex to yield useful results, a working model will be used to obtain the desired information experimentally.

A more detailed analysis of the behavior of such a correlator in the presence of constant-amplitude pulse jamming has been worked out in Table II, which is laid out in accordance with the values envisioned for the working model under construction. These values are: $m = k = 4$, hence

$A = 3 + \alpha$. All possible values of M and K are considered, and the probability of occurrence p of each combination of M and K is calculated for the condition that the probability P , that a jam pulse will coincide with any particular place of the pulse train, is one-half. In this table, then, the first entry in each box is the probability of occurrence p of that box for $P = \frac{1}{2}$, the second entry is the signal V_Z present in the correlator adding bus in terms of the signal and jam intensities S and J respectively, the third entry is the threshold voltage in terms of S , J , α , and B , and the last entry is the S/J ratio necessary to obtain an output. It should be noted that, except in the first column of the table, α occurs only in the numerator and B only in the denominator of the S/J expressions, indicating that for sufficiently small α and sufficiently large B , S/J ratios appreciably smaller than one will still give satisfactory operation. This can be seen more clearly from the curves in Fig. 5, which, for $\alpha = 1$ and various values of B , show the probability of obtaining an output due to a "correct" pulse-train input in the presence of constant amplitude pulse jam of signal-to-jam ratio S/J and of probability of occurrence of a jam pulse $P = \frac{1}{2}$.

Behavior of Pulse-Train Correlator in Presence of Noise

In order to evaluate the reliability of the pulse-train correlator in the presence of noise, and to aid in the choice of values for threshold parameters, it would be desirable to calculate the probability of an output for a given assumed probability distribution of the noise, for the following cases: (1) noise alone, (2) noise combined with a correct signal, (3) noise combined with pulse jamming, and (4) noise plus pulse jamming plus correct signal. An attempt has been made during this report period to carry out this calculation for the first case, assuming that the noise amplitude x_i at the i -th tap has a probability density $\phi(x_i)$, $0 < x_i < \infty$, and a corresponding cumulative probability distribution

$$\Phi(x_i) = \int_0^{x_i} \phi(t) dt. \quad \text{The probability of an output from the correlator is}$$

$\text{pr} \{V_Z - V_T > 0\}$, and since V_Z and V_T are not independent, this probability depends on their joint density, which for a general $\phi(x_i)$ appears to have a very complicated form. If m and k are large, however, since V_T is calculated from only three of the x_i while V_Z depends on all $m + k$ of them, it appears that only a small error would result from assuming the independence of V_Z and V_T . Hence it may be of some interest to write, in multiple integral form, the separate density functions $f_1(V_Z)$ and $g_1(V_T)$:

$$f_1(V_Z) = \frac{d}{dV_Z} \left[\int_{\max\{0, -V_Z\}}^{\infty} \int_0^{V_Z + \eta} f_2(\xi) f_3(\eta) d\xi d\eta \right]$$

where

$$f_2(\xi) = \frac{d}{d\xi} \left[\int_0^{\xi} \int_0^{\xi - x_1} \dots \int_0^{\xi - x_1 - x_2 - \dots - x_{m-1}} \phi(x_1) \phi(x_2) \dots \phi(x_m) dx_m \dots dx_2 dx_1 \right]$$

$$\text{and } f_3(\eta) = \frac{d}{d\eta} \left[\int_0^\eta \int_0^{\eta-x_{m+1}} \dots \int_0^{\eta-x_{m+1}-\dots-x_{m+k-1}} \phi(x_{m+1}) \dots \phi(x_{m+k}) dx_{m+k} \dots dx_{m+1} \right].$$

$$g_1(V_T) = \frac{d}{dV_T} \left[\int_{\max\{0, -\frac{V_T}{B}\}}^\infty \int_0^{\frac{V_T+Bv}{A}} g_2(u, v) du dv + \int_{\min\{0, -\frac{V_T}{A+B}\}}^0 \int_{-v}^{\frac{V_T+Bv}{A}} g_2(u, v) du dv \right]$$

$$\text{where } g_2(u, v) = -\frac{\partial^2}{\partial u \partial v} \left[\int_{\max\{0, v\}}^{u+v} \int_{w-v}^u \int_{y+v}^{u+w} g_3(y, z, w) dz dy dw \right. \\ \left. + \int_{\max\{0, v\}}^\infty \int_0^{w-v} \int_w^{u+w} g_3(y, z, w) dz dy dw \right]$$

$$\text{and } g_3(y, z, w) = k m(m-1) [\Phi(y)]^{k-1} [\Phi(z) - \Phi(w)]^{m-2} \phi(y) \phi(z) \phi(w).$$

In these equations, ξ and η represent the sums of the noise voltages at

the m taps and the k taps respectively; that is, $\xi = \sum_{i=1}^m x_i$ and

$\eta = \sum_{j=1}^k x_{m+j}$. Also, y , z , and w represent k_{\max} , m_{\max} , and m_{\min} (when

noise alone is present) and u and v represent $\max\{y, z - w\}$ and $\min\{w, z - y\}$ respectively, so that $V_T = Au - Bv$.

Although noise coming out of a detector would usually be assumed to have a Gaussian-type probability density (but for positive values of x_i only) the above equations can only be utilized for a density function which has an indefinite integral. For this reason, attempts are being made to simplify the above integrals for such simple density functions as $\phi(x) = e^{-x}$ ($0 \leq x < \infty$), $\phi(x) = 1$ ($0 \leq x \leq 1$) and $\phi(x) = 1 - \frac{x}{2}$

($0 \leq x \leq 2$).

Reliability as a Function of Frequency

The use of a rotating directional airborne antenna at the airplane as part of a system to obtain geometric security has been suggested in the previous reports. Mechanical requirements for such an antenna system dictate that its size should be as small as possible, while the electrical considerations indicate that the size should be large. The latter requirement arises from the increased attenuation of shorter waves in the atmosphere under adverse weather conditions, and from the need for narrow beam angles. These two conflicting requirements indicate that a survey study to determine the optimum operating frequency for such a system is justified. Such a survey should include: (1) obtaining world-wide climatological data, (2) obtaining data giving centimeter-wave attenuation as a function of rainfall, and (3) determining the relation between equipment size and system power requirements at various wavelengths. Problems involved in the design of the antenna are already being investigated at AFCRC and need not be included in this study.

A study of the first aspect of the problem is being made, with the object of determining the worst expected rainfall and cloud conditions under which the system will be required to operate. Rainfall records which are usually available only for widely separated locations constitute a very unsatisfactory basis for estimating these conditions, since the lateral extent of the rain at a given instant is of primary importance. In fact, for the range required for IFF transmission, the rainfall rate along a 200-mile line of sight is of interest. Beyond 200 miles the line of sight is at an altitude (above 20,000 feet) where no appreciable liquid precipitation is present.

It is evident from climatological records that the heaviest rainfall in the world occurs in low latitudes, particularly in India, Southeast Asia, Indonesia, and the equatorial regions of South America and Africa. Figure 11 of Reference 6 indicates that at six locations in Indonesia and Ceylon, a rainfall rate of approximately 100 mm/hr is the heaviest for a 30-minute period to be expected in any given year. The world's record for this period is a rate of about 450 mm/hr. A 30-minute period is chosen arbitrarily as an indication that the rainfall is not the result of showers which cover only a small area and pass quickly over a given point, but even in widespread areas of rain, the average intensity is apparently very much less than the maximum. Hence, it appears that an average rainfall rate of 50 mm/hr for a 200-mile distance would very rarely be exceeded anywhere in the world.

Considering only temperate zone climates, such as the United States, it appears that a much lower figure can safely be used. A survey⁷ of the Muskingum Valley in Ohio for the year 1938 showed that for only 20 hours in the entire year was there a rate in excess of 10 mm/hr for 50 miles in any direction from a central point in the valley. Hourly records^{7,8} at individual locations in various parts of the U.S. indicate that only in the worst storms have there been total falls of more than one inch in an hour, or more than 6 inches in 12 hours. Hence, it appears that an average rate of .5 in/hr (or about 12.5 mm/hr) for a 200-mile distance would rarely be exceeded in temperate latitudes.

It is also difficult to obtain specific data as to the probability of having clouds or fog with a given concentration of water droplets over a given area. However, it is apparently not unusual to have nearly saturated clouds over distances of 200 miles, and hence allowance must be made for maximum possible attenuation due to clouds. Using the limit of approximately 1 gm/m³ of liquid water, without appreciable precipitation, in clouds at 18°C (less at lower temperatures), calculations⁶ show that even this maximum possible attenuation due to clouds or fog is in all cases of a lower order of magnitude than the attenuation due to heavy rainfall. Hence there is no necessity to consider clouds and fog alone, without rain, and the case of saturated clouds interspersed between rain areas may safely be considered to be included in the ample allowances for rainfall suggested above.

The analysis below is given to demonstrate quantitatively the effect of attenuation due to climatological conditions on the performance of the ground-to-air, or air-to-ground, link. A convenient measure of performance for this analysis is the free-space maximum range R_o defined by

$$R_o = \frac{\sqrt{G_t G_r}}{4\pi} \lambda \sqrt{\frac{P_t}{P_{min}}}$$

where G_t = gain of transmitting antenna

G_r = gain of receiving antenna

λ = wavelength

P_t = radiated peak power

P_{min} = minimum useful received power

For a given receiver sensitivity (P_{min}) this equation reduces to

$$R_o = k \lambda \sqrt{P_t}$$

The curves of Fig. 6 show the relationship between free-space range and transmitted peak power for three different wavelengths. In computing the values used in making these plots, the following data concerning the system were assumed: $G_t = G_r = 120$, $P_{min} = 128$ db below one watt. These data are in agreement with the requirements of the rotating-antenna scheme described in the previous reports.

The equations used above assume no attenuation due to rainfall, clouds, or fog; and when this assumption is not valid the maximum range for a given P_t will be reduced below the free-space values. Under such conditions, the ideal value can be regained by an appropriate increase in

transmitted power, i.e. by an amount corresponding to the additional db loss in the transmission path. This has been done for the two hypothetical rainfall figures discussed above (50 mm/hr for 200 miles, and 12.5 mm/hr for 200 miles), and the results are shown in Fig. 7. The attenuation figures used in making the calculations upon which these plots are based were estimated from published results^{6,7,10}. Also included were inherent transmitter losses. Not included, however, was the effect on the field intensity of the presence of the earth¹⁰.

Equipment Reliability

Transistor Testing

The miniaturization which can be achieved by transistor circuitry, the small power requirements of the transistor, and its ability to withstand severe shock and vibration, are some of the more outstanding qualities which enhance the position of the transistor as a replacement for the vacuum tube. However, characteristics such as limited high-frequency response, and comparatively small power-handling capacity restrict the application of the transistor. Miniaturized switching circuits and flip-flop types of storage devices are two of the more immediate applications in which transistors may prove highly effective.

In order to obtain sufficient data on individual transistors, a testing program is in the process of being organized at Northeastern. At present the commercial transistor production methods do not include any effective system of quality control, and the characteristics vary considerably from one unit to the next. It is, therefore, necessary to have some method of testing to provide the required information for transistor-circuit design. A program of this nature also provides a method of orienting personnel in this relatively new field.

The transistor testing program has been initiated by one engineer and a full-time student assistant working in close coordination with the transistor testing group at the Air Force Cambridge Research Center. The purpose of this arrangement is to provide a training period for the personnel and to make sure that the testing program at Northeastern is fundamentally the same as that used at the Research Center. It is intended that Northeastern will eventually carry out the bulk of the initial testing for its own purposes and also for the Cambridge Research Center.

The testing program will include the measurement of both large and small-signal parameters of the point-contact n-type transistor. The small-signal parameters are r_{11} , r_{12} , r_{21} , and r_{22} . These are the standard four-terminal equivalent resistances of the transistor, considered as the four-terminal network shown below.

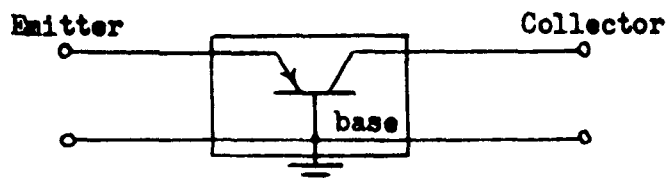

These small-signal parameters are measured with the transistor in a grounded-base type circuit. A fifth small-signal measurement is alpha (α), defined as the ratio of the change in collector current to a change in emitter current made at constant collector voltage. A value for the upper cut-off frequency is also obtained for each transistor.

The large-signal test which is made on the transistor consists of applying a rectangular current pulse to the emitter circuit and measuring the rise and fall time of the collector-circuit response. The ratio of the magnitude of the collector current to that of the emitter-current pulse defines alpha for large signals. Some transistors exhibit an unusual delay characteristic which can be measured during the above test. The parameter which expresses this delay and is of considerable importance to circuitry in which transistors are to be pulsed is the hole-storage time. It is a limiting factor on the minimum usable width of control pulse. Hole-storage time has been defined as the time between cut-off of the emitter current and the resulting cut-off of the collector current. If a transistor is placed in a grounded-emitter circuit as shown below, and a square-wave of long period and sufficient magnitude is applied to the base, hole-storage time may be measured from the output waveform as shown.

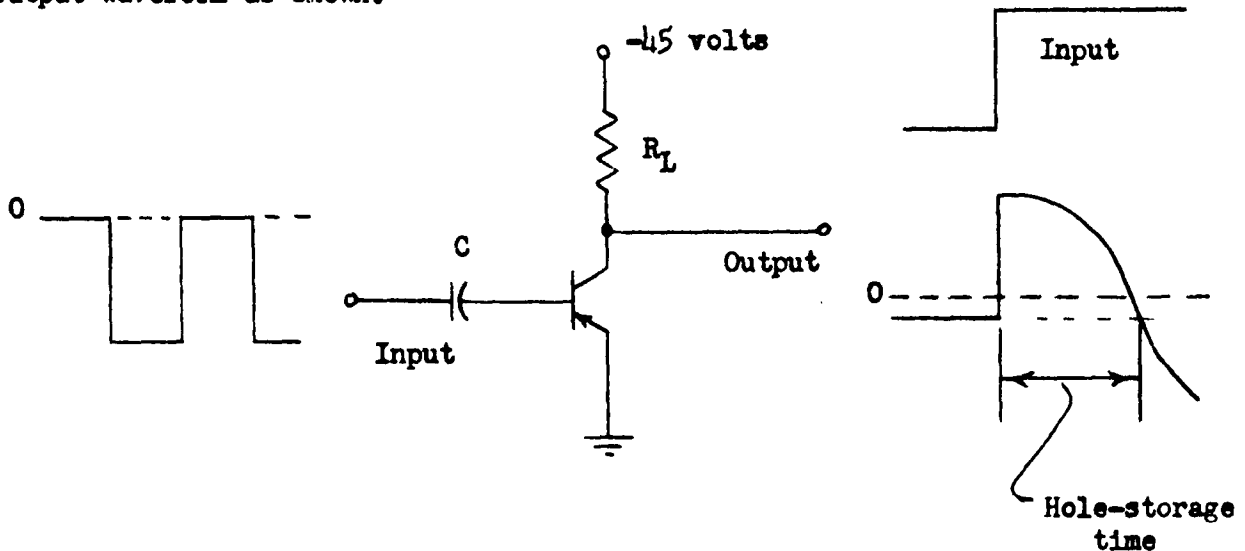

e. Apparatus and Equipment

Pulse-Train Correlator Working Model

When implementing the scheme of a pulse-train correlator, presented in the section Methods of Attack of this report, the first question that needs to be decided is what type of coupling should be employed in the amplifiers and computer elements. Three types of coupling circuits were considered: (1) direct coupling, (2) conventional R-C coupling, and (3) R-C coupling with clamping. Of these, direct coupling must be considered to be the most conservative design, there being no question of shift of base level with pulse-repetition frequency or due to a brief instantaneous noise peak, as would be experienced with coupling circuits (2) or (3) respectively. For the design of this experimental model, therefore, either actual direct coupling or circuits that achieve the results of direct coupling were

employed, keeping in mind the possibility of determining the effects of the other coupling methods when the model is operating.

Now consider a length of delay line, followed by an amplifier whose gain is set to just compensate for the attenuation of the line, so that the overall gain is equal to one.

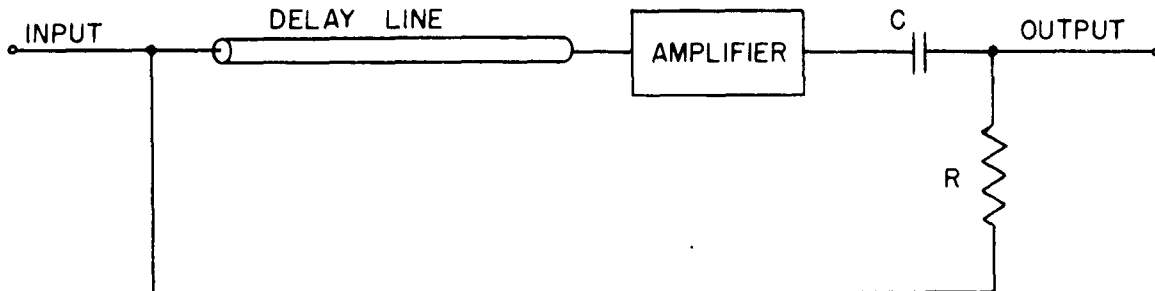

We may obtain the over-all response of direct-coupled circuitry and still use condenser coupling in the amplifier, if we return the resistor of the last coupling circuit to the input instead of to ground, at the same time making the R-C time-constant of that circuit very long compared to the delay time of the line, and making the time-constants of any previous coupling circuits within the amplifier long compared to the last one. (That this circuit will very nearly give the proper response down to zero frequency can readily be seen by analyzing it with a step-voltage.) This scheme, then, is used in the design of the working model, thus permitting the in-line amplifiers and the tap phase-inverters to be condenser-coupled. A separate d-c phase-inverter of a gain of minus one is used to provide a point to which the output coupling resistors of the tap phase-inverters are returned. A schematic of the first half of the correlator is given in Fig. 8 which shows the input tap and phase inverter, a typical in-line amplifier and tap phase-inverter, and the d-c phase-inverter.

The formula for the threshold voltage

$$V_T = A \max \{k_{\max}, m_{\max} - m_{\min}\} - B \min \{m_{\min}, m_{\max} - k_{\max}\}$$

which was developed in the Methods of Attack section, implies three subtractions of voltages, which would have to be performed by three direct-coupled phase inverters and adding circuits. This is undesirable since each d-c phase inverter requires a tube with separate gain and zero-setting controls. In the interest of fewer controls it was therefore decided to remove the need for subtraction in the threshold computer by transforming the formula, using the identity $-m_{\min} = (-m)_{\max}$. We then have:

$$\begin{aligned} V_T &= A \max \{k_{\max}, m_{\max} - m_{\min}\} + B \max \{(-m)_{\max}, k_{\max} - m_{\max}\} = \\ &= A \max \{k_{\max}, m_{\max} + (-m)_{\max}\} + B \max \{(-m)_{\max}, k_{\max} + (-m)_{\min}\} \end{aligned}$$

That this transformation allows for economy of equipment is seen from the fact that the $(-m)$ voltages are available at the tap phase-inverters.

Figure 9, which is a schematic of the second half of the correlator, shows how by means of crystal diodes the four required voltages k_{max} , m_{max} , $(-m)_{max}$, and $(-m)_{min}$ are produced, and how by resistive averaging circuits and further crystal rectifiers the coefficients of A and B are generated. These then are amplified in separate direct-coupled amplifiers with individual gain controls, and finally averaged together to give the threshold voltage. Another crystal diode and a pulse transformer perform the comparison between the threshold voltage and the adding-bus signal.

Pulse-Train Generator

A pulse-train generator has been constructed to generate an eight-digit number consisting of 0.6-microsecond pulses spaced at intervals of 1.8, 4.2, 3.6, 1.2, 7.2, 3.0, and 2.4 microseconds respectively. The repetition rate of the number is variable from approximately 2 to 11 kc. Single-pulse operation is also possible.

The block diagram, shown in Fig. 10, sub-divides the pulse-train generator into four functional groups: the pulse-train initiator, the digit generators, the output generator, and the synchronizing-pulse generator.

The pulse-train initiator, shown in Fig. 11, consists of a free-running multivibrator (T2) and a single pulser (T1) to allow continuous or single-pulse operation respectively. The free-running multivibrator is of the conventional type with the grid-bias return variable from zero to plus 200 volts for a frequency variation from approximately 2 to 11 kc. The single pulser uses a type 2D21 gas tetrode which generates a positive-going voltage at the cathode each time the single-pulse push-button switch is depressed. A DPDT switch allows either output to be fed to the synchronizing-pulse generator and to the digit-1 generator. The free-running multivibrator is made inoperative during single-pulse operation by returning the grid bias to minus 200 volts by the aforementioned switch.

A typical digit generator is shown in Fig. 12. Tube T1 is an amplifier used to plate-trigger the conventional one-shot cathode-coupled multivibrator T2. The input to T1 is from the pulse-train initiator in the case of the digit-1 generator, and from the preceding digit generator in the case of digit-2 to 8 generators. The output from the normally conducting plate of the multivibrator is differentiated at the input of amplifier T3. A positive pulse is generated at the plate of T3 when the plate of the multivibrator returns to its normally low level. Amplifier T3 then feeds into pulse amplifier T4 to obtain a pulse at its plate which is tied through the digit switch and the adding bus to the output generator. Amplifier T3 also feeds into the pulse amplifier at the input of the following digit generator, thus initiating its one-shot multivibrator to generate the pulse for the next digit. The delay of the one-shot multivibrator in the digit-1 generator can be set to an arbitrary number of pulse widths to delay the start of the train from the initiating pulse, but the delay of the one-shot multivibrators in the digit-2 through 8 generators must be set for 3, 7, 6, 2, 12, 5, and 4

pulse widths respectively by means of their delay capacitors. The presence or absence of a pulse on the adding bus to the output generator is controlled by the setting of the digit switches. Synchronizing pulses spaced at one pulse width are fed to each of the digit one-shot multivibrators so that they can only generate delays that are integral multiples of one pulse width.

The output generator, shown in Fig. 13, contains a conventional one-shot cathode-coupled multivibrator (T1), two cathode followers (T2 and T3), and a crystal-diode slicing circuit. The one-shot multivibrator generates a positive pulse of 0.6-microsecond duration at its normally low plate each time a pulse appears on the adding bus. The final output is coupled from the multivibrator through a cathode follower (T2) to a crystal-diode slicing circuit to cut out any noise at the base line and at the peaks of the pulses due to the synchronizing pulses. The slicing circuit feeds the output cathode follower (T3). The output pulse obtained is 20 volts in amplitude with a rise and fall time of 0.1 microseconds when feeding a capacitive load of 100 $\mu\mu$ fds.

A synchronizing-pulse generator, shown in Fig. 14, was incorporated into the pulse-train generator in order to insure time stability. Pulse amplifier (T1), fed by the initiating pulse, plate triggers a conventional type flip-flop (T2). The left plate of the flip-flop drops enough to cut off the cathode follower switch circuit (T3), allowing the transitron oscillator (T4) to operate. The variable L-C tank circuit in the cathode of T3 is adjusted to oscillate at a period of 0.6 microseconds. The potentiometers in the cathode of the oscillator control the stability and amplitude of oscillations. Tubes T5 and T6 are clipper amplifiers, the output of T6 being differentiated at the input of peaker T7. The negative pulses generated at the plate of peaker T7 are the synchronizing pulses fed to the various one-shot multivibrators. Tubes T8, T9, and T10 comprise a unit similar to the digit generators. The function of this unit, which is triggered from the digit-8 generator, is to return flip-flop T2, thereby making the synchronizing-pulse generator inoperative after some arbitrarily fixed delay (about 5 pulse widths) of one-shot multivibrator (T9). Therefore, synchronizing pulses are generated only for a time shortly preceding, to a time shortly following the pulse train.

Pulse-Jamming Generator

The pulse-jamming generator under development at the time of the last report writing has been completed in breadboard form. As initially specified, the pulse-repetition frequency is variable from 40 kc to 1 mc, and the pulse width is variable over the range of 0.5 to 1.5 microseconds. The rise and fall time of the pulse is less than 0.1 microsecond, and the pulse amplitude is fixed at 15 volts.

The final design of the pulse-jamming generator has been considerably simplified over the system originally contemplated. The circuit diagram is included in the Appendix as Fig. 15. The circuit consists of a free-running multivibrator followed by a cathode-coupled slicer

which in turn is followed by an output cathode follower.

The pulse-repetition frequency is made variable by a 40 to 1 variation of the resistance in the grid-return path of T1. The pulse width is made variable by varying the resistance in the grid-return path of T2. A large coupling capacitor connected between the plate of T1 and the grid of T2 provides for stability of operation over the entire frequency range.

Transistor Testing

The equipment to be used in measuring F_{11} , F_{12} , F_{21} , F_{22} and α (small signal) will be the Transistor Test Equipment Model T-61 manufactured by Transistor Products, Incorporated. This equipment is on order and should be delivered for use during the next report period.

The circuit and associated equipment used for cut-off frequency testing is shown in Fig. 16* of the Appendix. The Hewlett Packard Model 650-A Signal Generator and the Ballantine Model 304 Vacuum-Tube Voltmeter shown in the diagram, have been obtained. The circuit and associated equipment are now set up and ready for making frequency cut-off measurements.

The large-signal and hole-storage-time circuits have been combined on the same rack panel with a switching arrangement such as to reduce the number of equipment probe changes. The circuits and associated equipment are indicated in Fig. 17.

The Tektronix Type 105 Square-Wave Generator and Type 513-D Cathode-Ray Oscilloscope for large-signal testing have been obtained and are ready for making large signal measurements on point-contact n-type transistors.

g. Conclusions and Recommendations

1. The test set-up shown in Fig. 1 can be used to study the characteristics and effects of pulse and noise jamming, determine optimum methods of signal detection, and provide useful information for the evaluation of an IFF system employing filtering and correlation.

2. The use of optimum filtering techniques, such as those described in Fig. 3 for application in the i-f section of a pulse receiver, appears to provide promising means for increasing the S/N ratio prior to detection.

3. The formula derived herein for setting the threshold voltage in the pulse-train correlator appears to combat satisfactorily the effect of pure constant-amplitude pulse jamming. The circuits shown will generate the desired threshold voltage.

4. The design of the pulse generator appears satisfactory for its intended usage.

* This circuit and the one in Fig. 17 are essentially duplicates of those developed at AFCRC.

5. The pulse-train generator providing non-uniform symbol intervals operates as specified, and will fulfill satisfactorily its intended usage.

6. The survey to determine the optimum operating frequency is progressing satisfactorily. Climatological data presently available has yielded the following maximum expected densities of rainfall for a 200-mile path: 12.5 mm/hr in the temperate zone, 50 mm/hr in the tropics. Attenuation of centimeter waves due to rainfall would appear to be excessive for all wavelengths shorter than 5 cm in the tropic regions.

7. The transistor-testing program as outlined herein is sound as far as providing information useful to the design of transistor circuitry is concerned, and provides further insight into the behavior of transistors themselves.

h. Future Work

In view of the work of this and previous report periods, and the above conclusions and recommendations, it is intended that future work include:

1. The continuation of the various surveys already begun. These include: (a) the study of contemporary jamming and countermeasures techniques, (b) the study of ways by which correlation and filtering methods can be applied to IFF systems to improve system reliability, (c) the study of the use of redundancy in coding to reduce the probability of error, (d) the study of the response of the video detector to pulses in the presence of noise, and (e) the compilation of factual data concerning propagation effects at s and x-band frequencies in order that the desirable operating frequency for use with a directional rotating airborne antenna can be determined. In connection with the last-named study, future work would place emphasis on (a) obtaining additional data covering world-wide climatological conditions, (b) the inclusion of the effect of the presence of the earth on the attenuation of centimeter waves, and (c) determining the relation between equipment size and system power requirements.

2. A literature survey to determine the optimum pulse shape from the standpoint of time and frequency occupancy as well as equipment complexity.

3. The construction of an optimum filter for application in the i-f section of a pulse receiver.

4. The construction of the pulse-train correlator, and the testing of this unit to determine (a) the optimum values of the design parameters for various conditions of noise and pulse jamming, and (b) the amount of jam rejection possible with this device. Further attempts will also be made to calculate the performance of the correlator in the presence of noise.

5. The design and construction of those components used in the block diagram of Fig. 1 which have as yet not been discussed. The most important of these are the amplitude modulators and the carrier oscillators.

6. The use of the transistor test equipment to determine the small and large-signal parameters for transistors provided by AFCRC. This will include the cataloging of such data for future reference and evaluation. It is hoped that this information will be useful as a basis for making suggestions to transistor manufacturers that will result in better transistors for specific applications.

7. The beginning of the application of transistors to various circuit problems to be suggested jointly by the staff working under this item of the contract, and the personnel at AFCRC. This work will be under Item III, due to become effective on December 1, 1952.

UNCLASSIFIED

-24-

APPENDIX

a. Curves and Drawings

UNCLASSIFIED

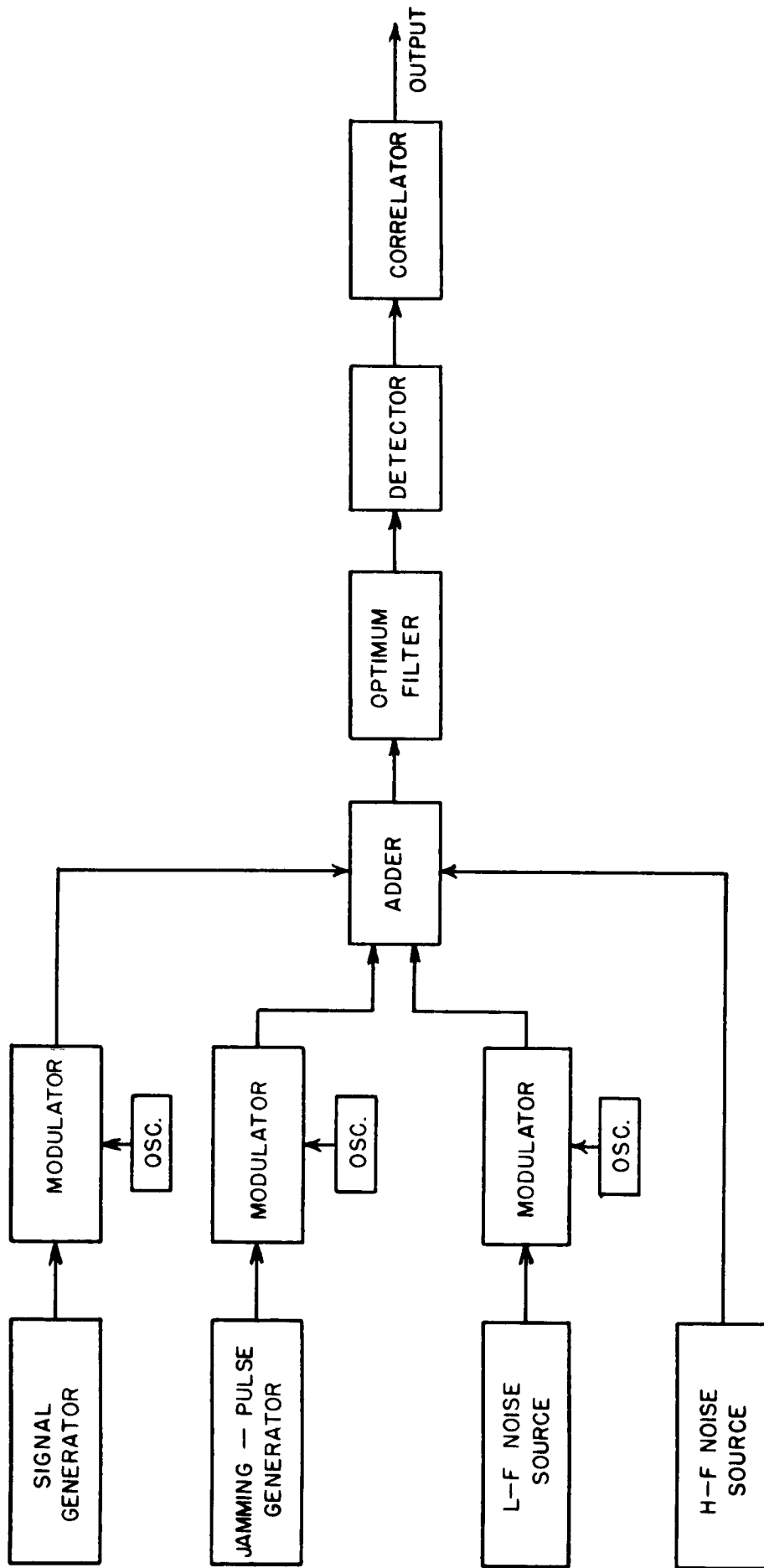

FIG. 1. BLOCK DIAGRAM OF PROPOSED TEST SET-UP.

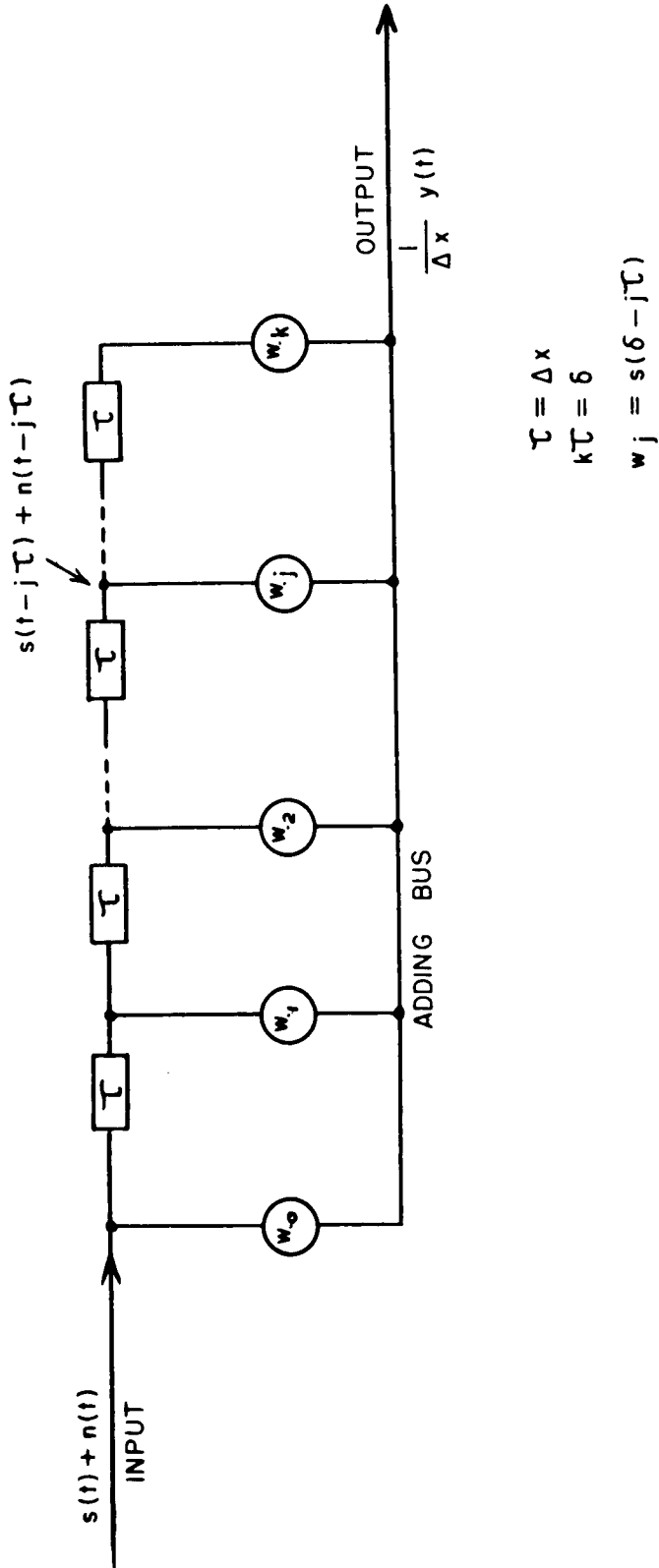
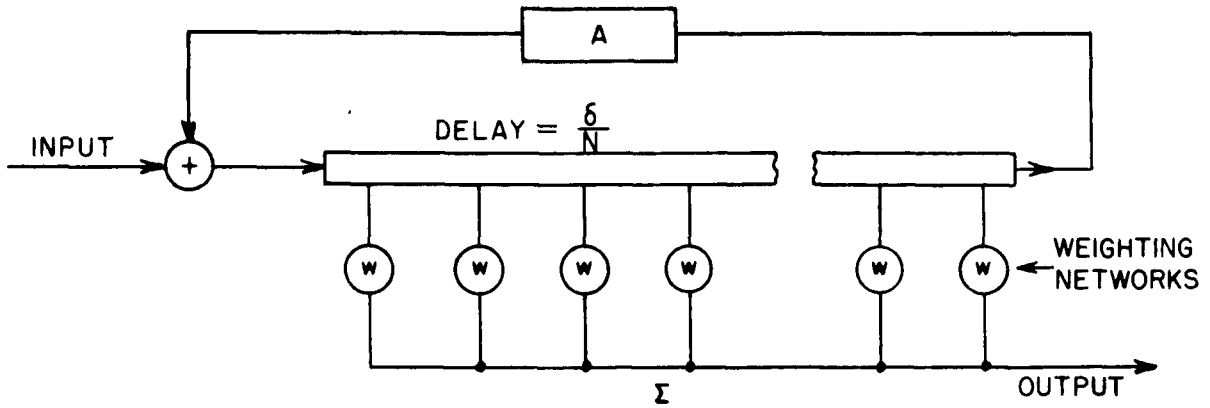
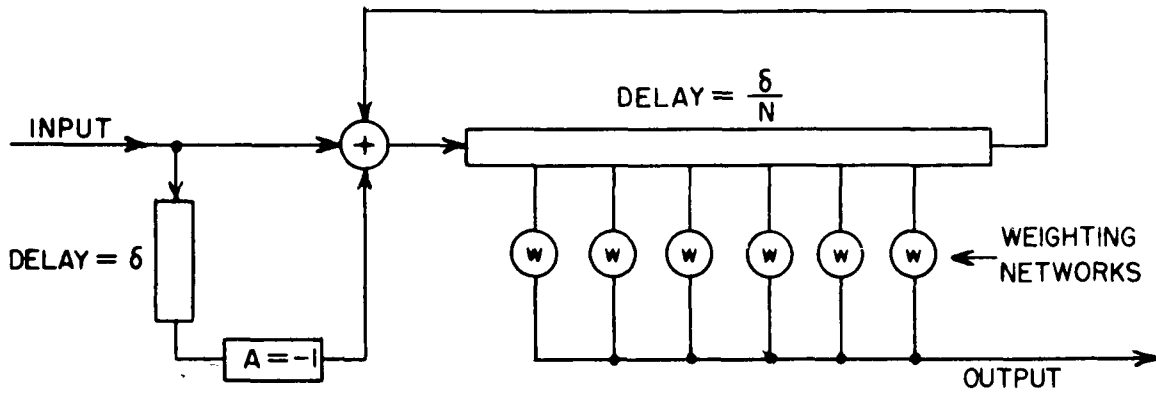

FIG. 2. BLOCK DIAGRAM OF OPTIMUM FILTER.



A. APPROXIMATE BAND-PASS FILTER



B. OPTIMUM FILTER FOR I-F SECTION

FIG. 3. DELAY-LINE FILTERS.

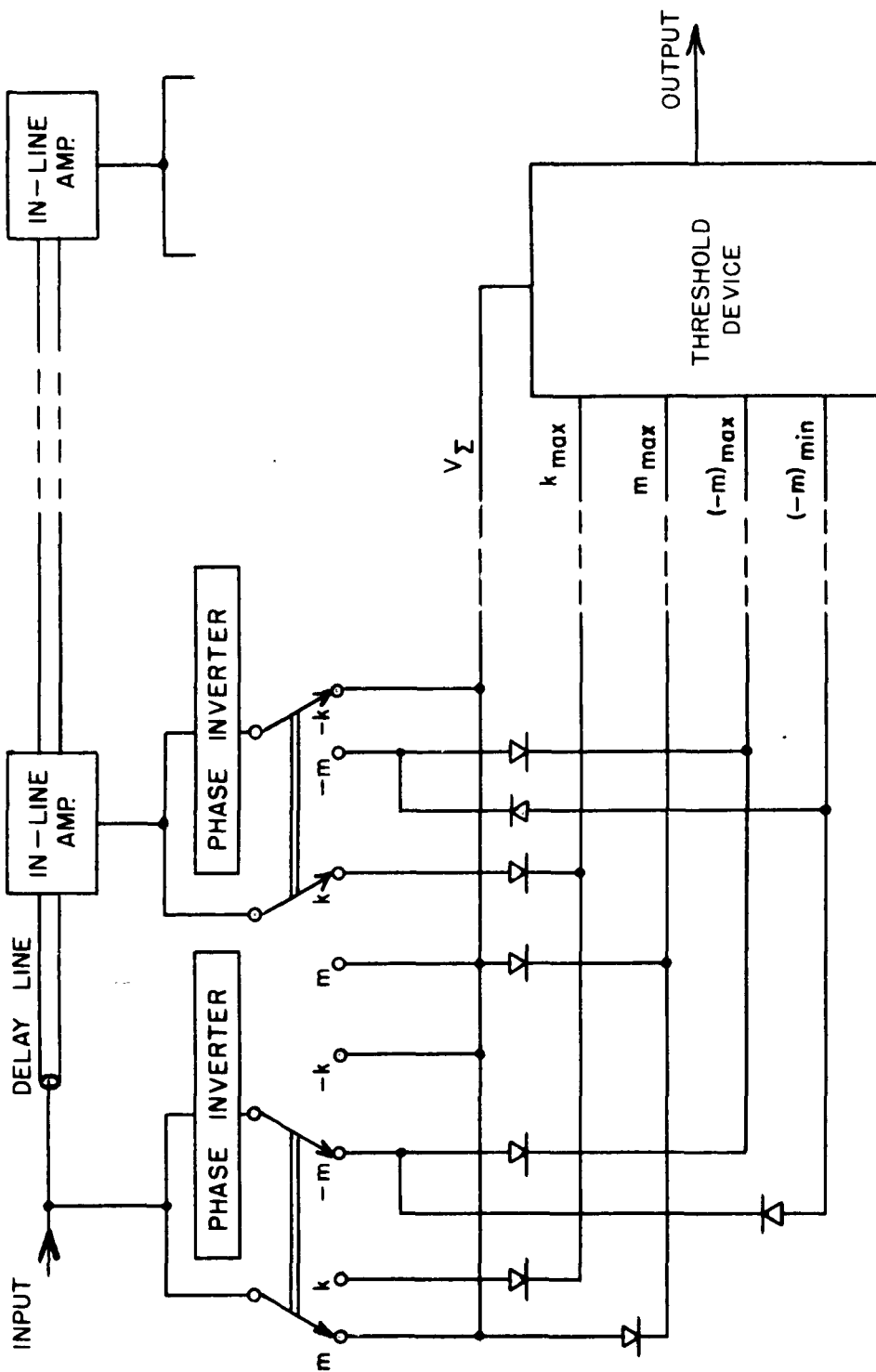

FIG. 4. BLOCK DIAGRAM OF PULSE - TRAIN CORRELATOR.

TABLE I. POSSIBLE JAM CONFIGURATIONS.

$\frac{M}{K}$	$M = 0$	$0 < M < m$	$M = m$
$K = 0$	<p>□□□□ ---</p> <p>(no jam)</p> <p>$V_T = -BS$</p>	<p>■□□□ ---</p> <p>$V_T = AJ-BS$</p>	<p>■■■■ ---</p> <p>(jam indistinguishable from signal)</p> <p>$V_T = -B(S+J)$</p>
$0 < K < k$	<p>□□□□ ■■ ---</p> <p>$V_T = AJ-B(S-J)$</p>	<p>■□□□ ■■ ---</p> <p>$V_T = AJ-BS$</p>	<p>■■■■ ■■ ---</p> <p>$V_T = AJ-BS$</p>
$K = k$	<p>□□□□ ■■■■</p> <p>$V_T = AJ-B(S-J)$</p>	<p>■□□□ ■■■■</p> <p>$V_T = AJ-BS$</p>	<p>■■■■ ■■■■</p> <p>$V_T = AJ-BS$</p>

$$V_T = A \max \left\{ k_{\max}, m_{\max} - m_{\min} \right\} - B \min \left\{ m_{\min}, m_{\max} - k_{\max} \right\}$$

■ JAM
□ SIGNAL

M	M=0	M=1	M=2	M=3	M=4
K=0 p=6.25%	$p=(1-P)^4=6.25\%$ $p=.39\%$ $V_Z=4S$ $V_T=BS$ $V_Z > V_T$ for all $\frac{S}{J}$	$p=4P(1-P)^3=25\%$ $p=1.56\%$ $V_Z=4S+J$ $V_T=(3+\alpha)J-BS$ $S > \frac{2+\alpha}{4+B}$	$p=6P^2(1-P)^2=37.5\%$ $p=2.34\%$ $V_Z=4S+2J$ $V_T=(3+\alpha)J-BS$ $S > \frac{1+\alpha}{4+B}$	$p=4P^3(1-P)=25\%$ $p=1.56\%$ $V_Z=4S+3J$ $V_T=(3+\alpha)J-BS$ $S > \frac{\alpha}{4+B}$	$p=P^4=6.25\%$ $p=.39\%$ $V_Z=4S+4J$ $V_T=B(S+J)$ $V_Z > V_T$ for all $\frac{S}{J}$
K=1 p=25%	$p=1.56\%$ $V_Z=4S-J$ $V_T=(3+\alpha+B)J-BS$ $S > \frac{4+\alpha+B}{4+B}$	$p=6.25\%$ $V_Z=4S$ $V_T=(3+\alpha)J-BS$ $S > \frac{3+\alpha}{4+B}$	$p=9.38\%$ $V_Z=4S+J$ $V_T=(3+\alpha)J-BS$ $S > \frac{2+\alpha}{4+B}$	$p=6.25\%$ $V_Z=4S+2J$ $V_T=(3+\alpha)J-BS$ $S > \frac{1+\alpha}{4+B}$	$p=1.56\%$ $V_Z=4S+3J$ $V_T=(3+\alpha)J-BS$ $S > \frac{\alpha}{4+B}$
K=2 p=37.5%	$p=2.34\%$ $V_Z=4S-2J$ $V_T=(3+\alpha+B)J-BS$ $S > \frac{5+\alpha+B}{4+B}$	$p=9.38\%$ $V_Z=4S-J$ $V_T=(3+\alpha)J-BS$ $S > \frac{4+\alpha}{4+B}$	$p=14.06\%$ $V_Z=4S$ $V_T=(3+\alpha)J-BS$ $S > \frac{3+\alpha}{4+B}$	$p=9.38\%$ $V_Z=4S+J$ $V_T=(3+\alpha)J-BS$ $S > \frac{2+\alpha}{4+B}$	$p=2.34\%$ $V_Z=4S+2J$ $V_T=(3+\alpha)J-BS$ $S > \frac{1+\alpha}{4+B}$
K=3 p=25%	$p=1.56\%$ $V_Z=4S-3J$ $V_T=(3+\alpha+B)J-BS$ $S > \frac{6+\alpha+B}{4+B}$	$p=6.25\%$ $V_Z=4S-2J$ $V_T=(3+\alpha)J-BS$ $S > \frac{5+\alpha}{4+B}$	$p=9.38\%$ $V_Z=4S-J$ $V_T=(3+\alpha)J-BS$ $S > \frac{4+\alpha}{4+B}$	$p=6.25\%$ $V_Z=4S$ $V_T=(3+\alpha)J-BS$ $S > \frac{3+\alpha}{4+B}$	$p=1.56\%$ $V_Z=4S+J$ $V_T=(3+\alpha)J-BS$ $S > \frac{2+\alpha}{4+B}$
K=4 p=6.25%	$p=.39\%$ $V_Z=4S-4J$ $V_T=(3+\alpha+B)J-BS$ $S > \frac{7+\alpha+B}{4+B}$	$p=1.56\%$ $V_Z=4S-3J$ $V_T=(3+\alpha)J-BS$ $S > \frac{6+\alpha}{4+B}$	$p=2.34\%$ $V_Z=4S-2J$ $V_T=(3+\alpha)J-BS$ $S > \frac{5+\alpha}{4+B}$	$p=1.56\%$ $V_Z=4S-J$ $V_T=(3+\alpha)J-BS$ $S > \frac{4+\alpha}{4+B}$	$p=.39\%$ $V_Z=4S$ $V_T=(3+\alpha)J-BS$ $S > \frac{3+\alpha}{4+B}$

TABLE II. ADDING-BUS AND THRESHOLD VOLTAGES (m=k=4, P=1/2).

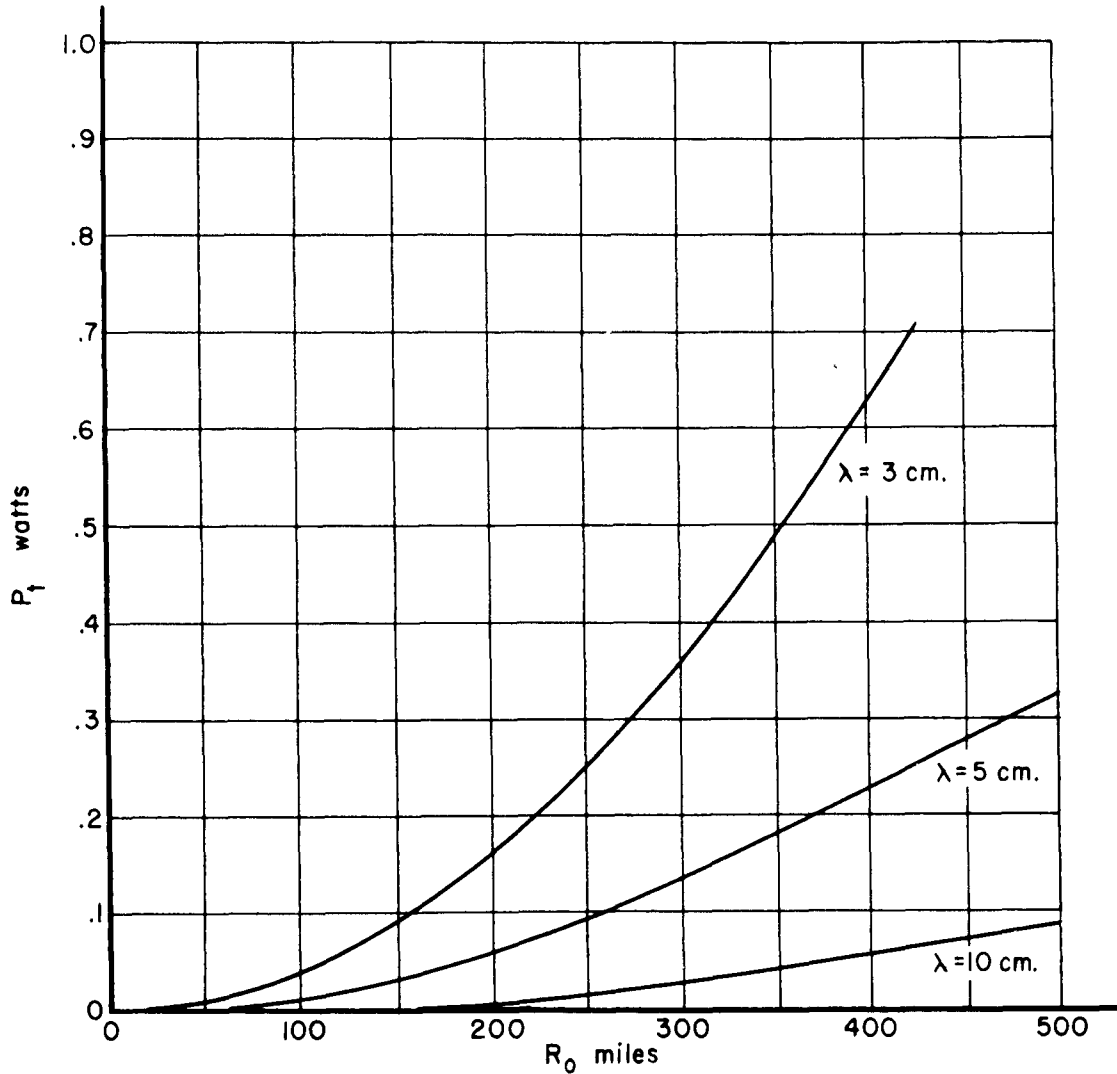

$$R_0 = \frac{\lambda \sqrt{G_t G_r}}{4 \pi} \sqrt{\frac{P_t}{P_{\min.}}}$$

$$P_{\min} = 128 \text{ db below 1 watt}$$

$$G_t = G_r = 120$$

FIG. 6. FREE-SPACE RANGE FOR ONE-WAY TRANSMISSION.

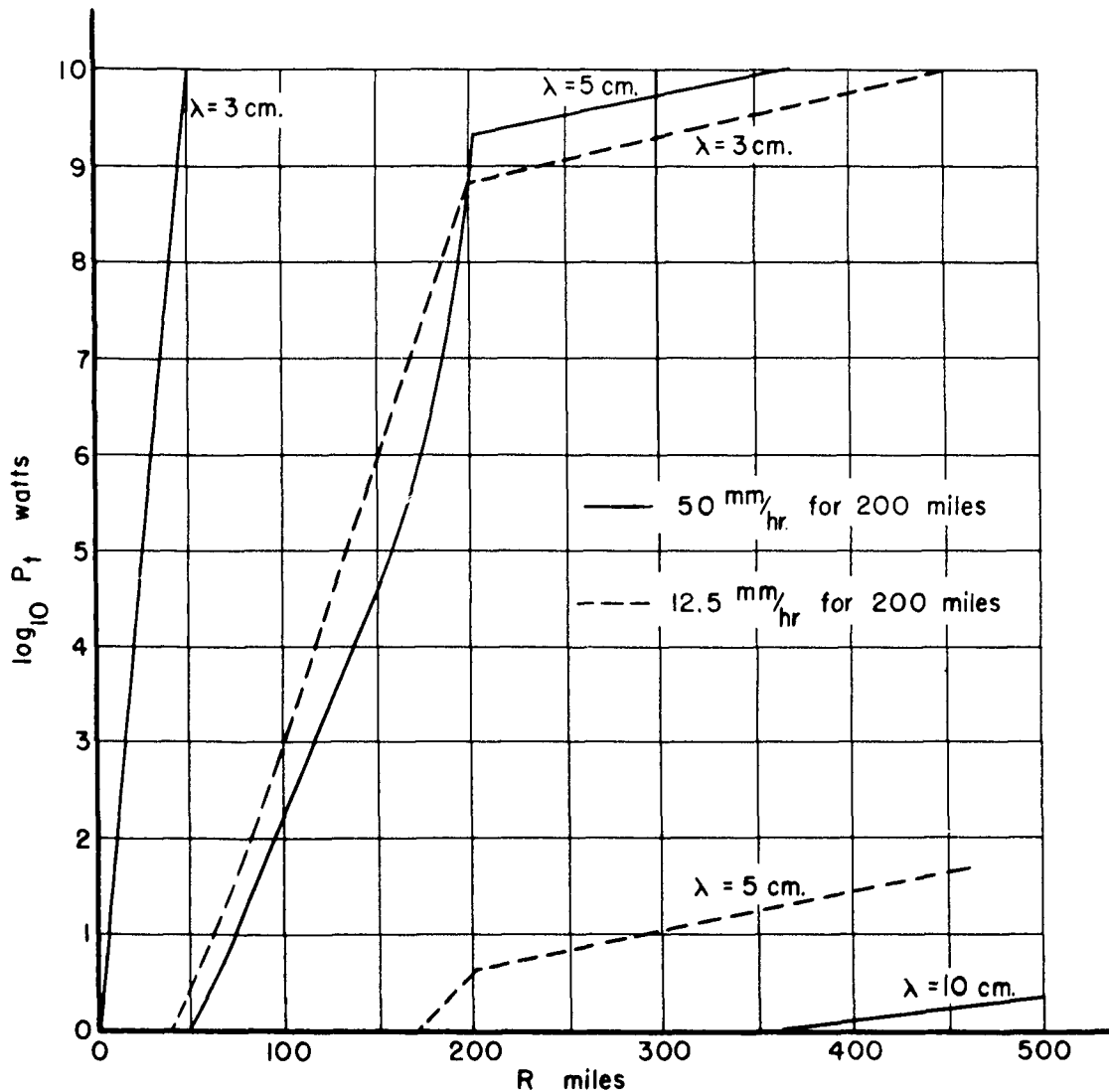

$$R = \frac{\lambda \sqrt{G_t G_r}}{4 \pi} \sqrt{\frac{P_t}{P_{\min.}}}$$

$$P_{\min} = 128 \text{ db. below 1 watt}$$

$$G_t = G_r = 120$$

FIG. 7. EFFECTIVE RANGE FOR ONE-WAY TRANSMISSION THROUGH RAIN.

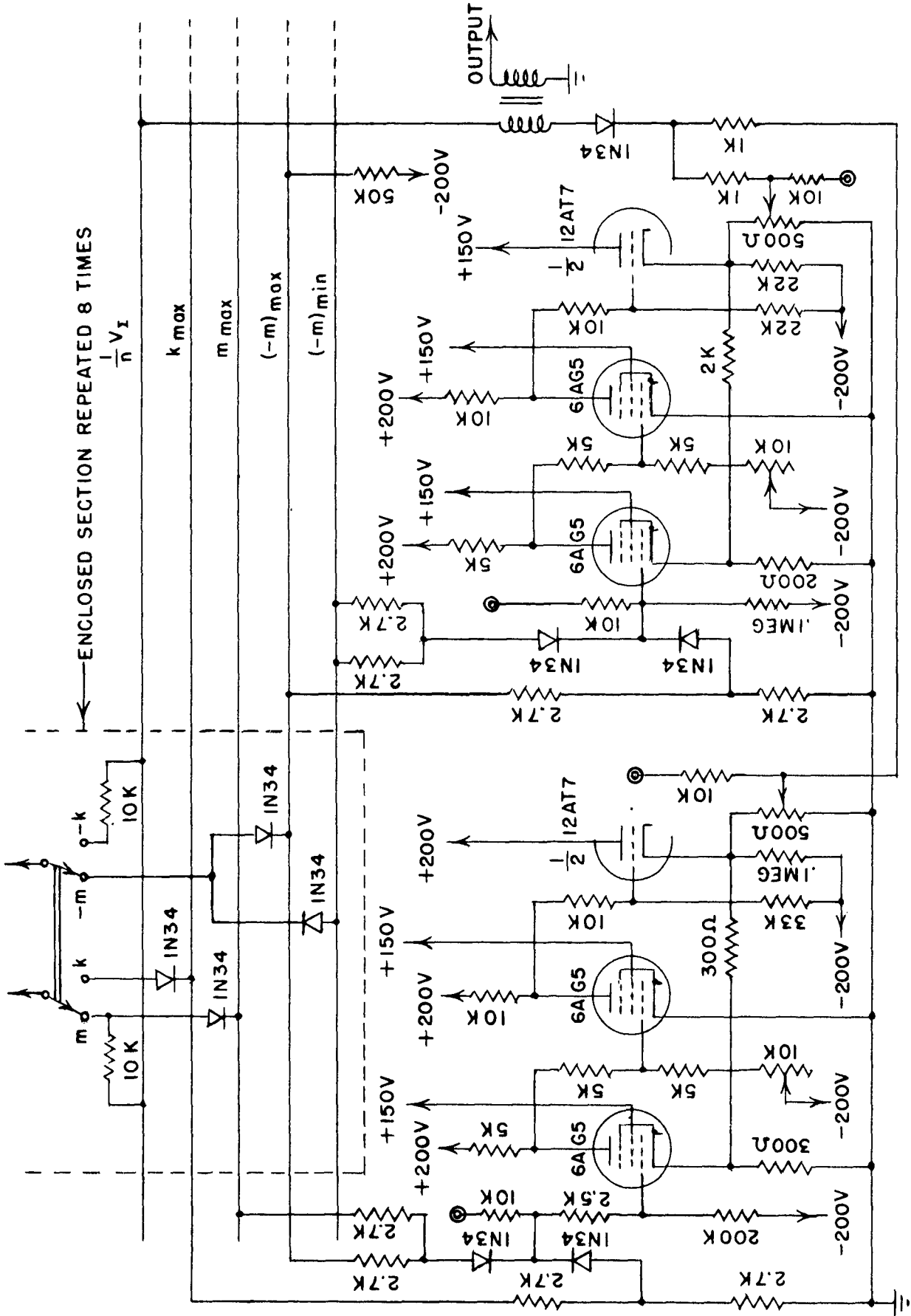

FIG. 9. SCHEMATIC OF PULSE-TRAIN CORRELATOR (SECOND HALF).

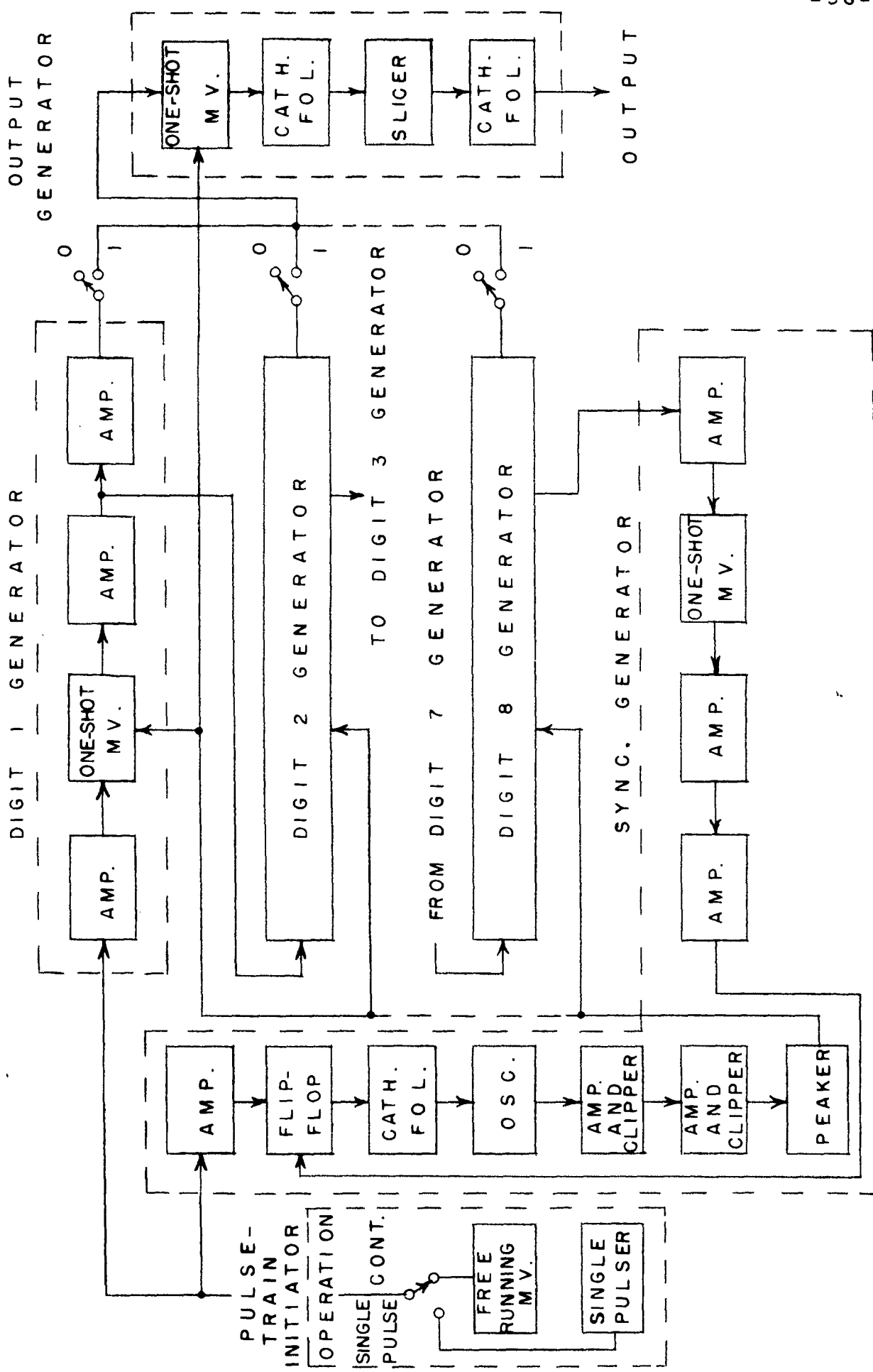
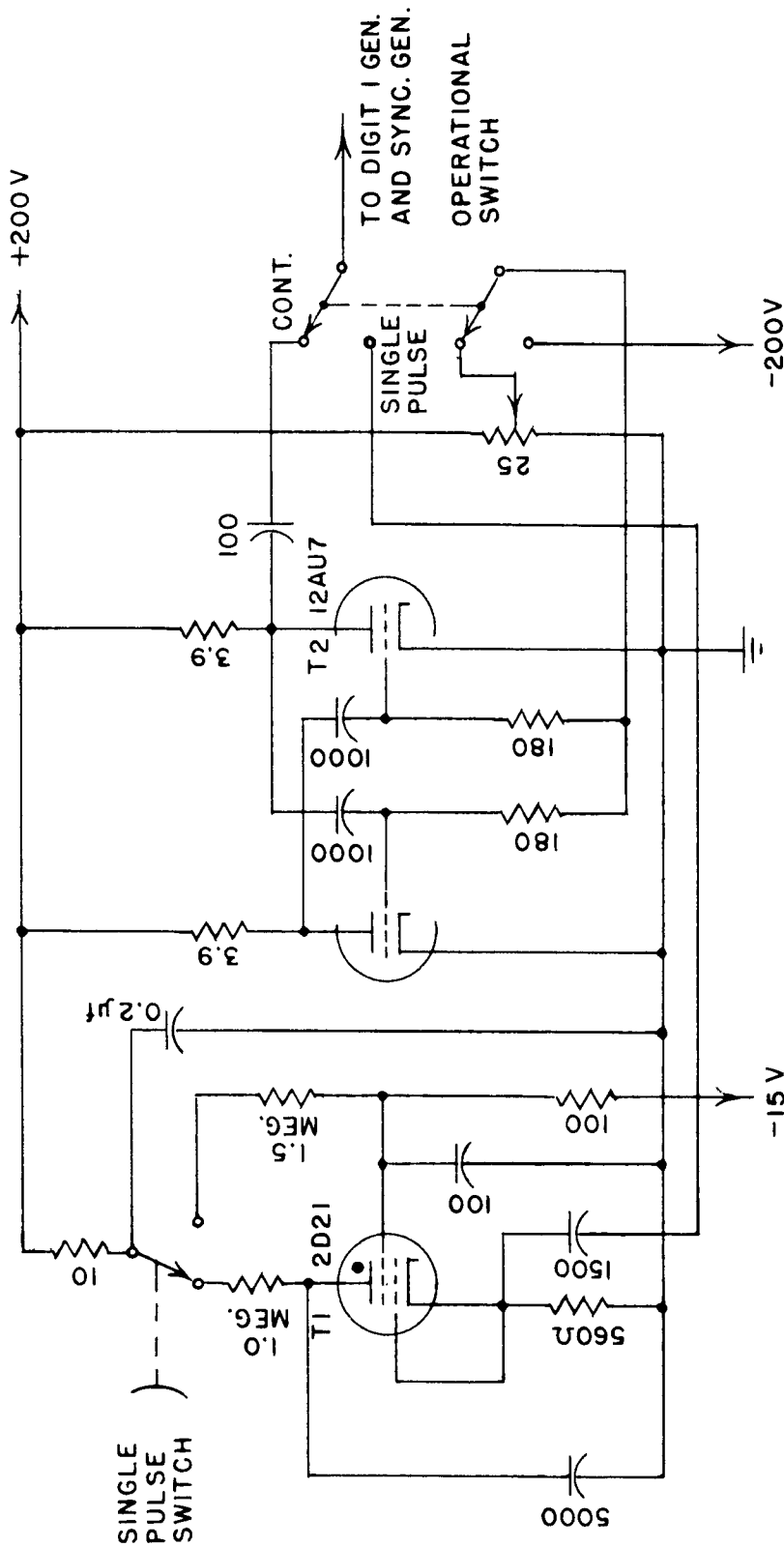
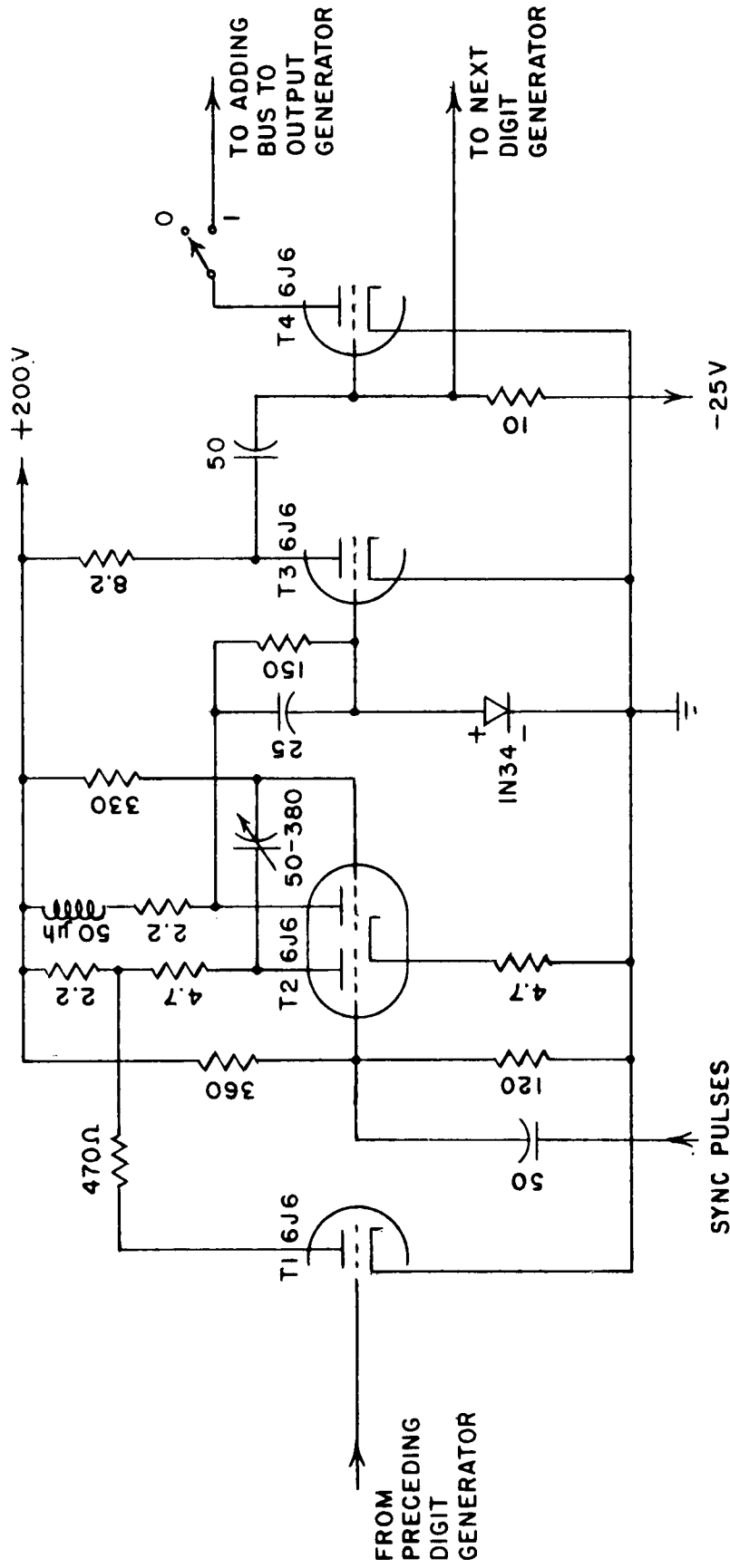

FIG. 10. PULSE - TRAIN GENERATOR.



NOTE: ALL RESISTANCE VALUES IN KΩ AND ALL CAPACITANCE VALUES IN μμf UNLESS OTHERWISE SPECIFIED.

FIG. 11. PULSE-TRAIN INITIATOR.



NOTE: ALL RESISTANCE VALUES IN KΩ AND ALL CAPACITANCE VALUES IN μμf UNLESS OTHERWISE SPECIFIED.

FIG. 12. TYPICAL DIGIT GENERATOR.

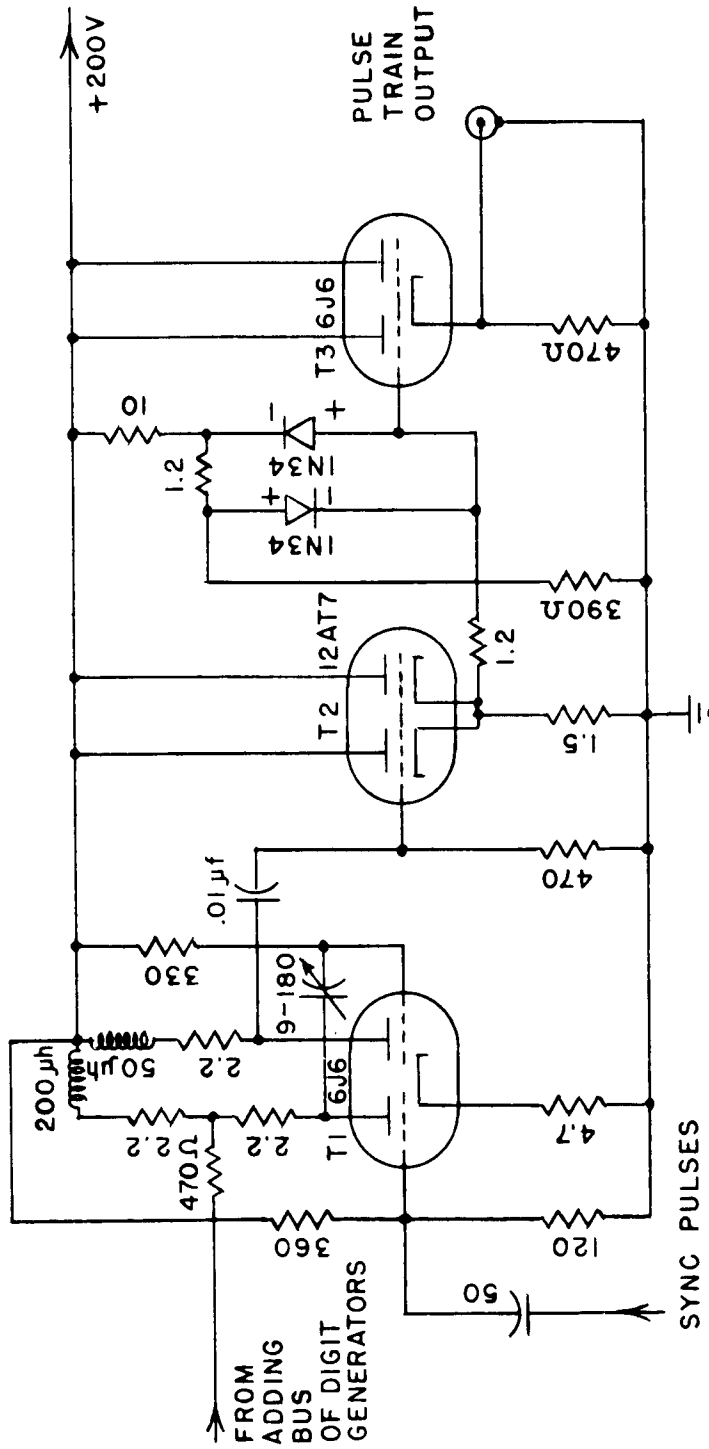

NOTE: ALL RESISTANCE VALUES IN KΩ AND ALL CAPACITANCE VALUES IN μμf UNLESS OTHERWISE SPECIFIED.

FIG. 13. OUTPUT GENERATOR.

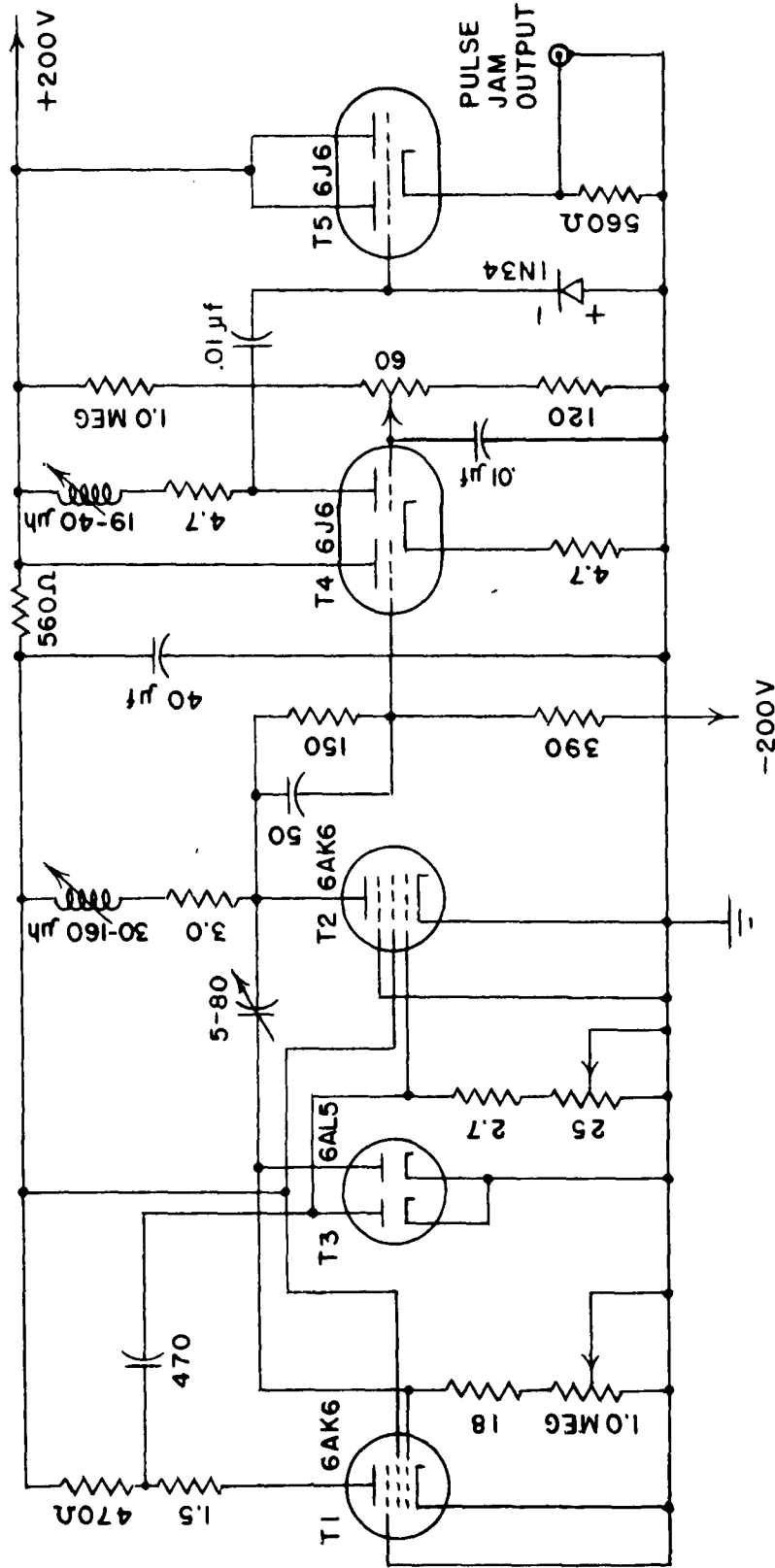

NOTE: ALL RESISTANCE VALUES IN KΩ AND ALL CAPACITANCE VALUES IN μf UNLESS OTHERWISE SPECIFIED.

FIG. 15. PULSE-JAMMING GENERATOR.

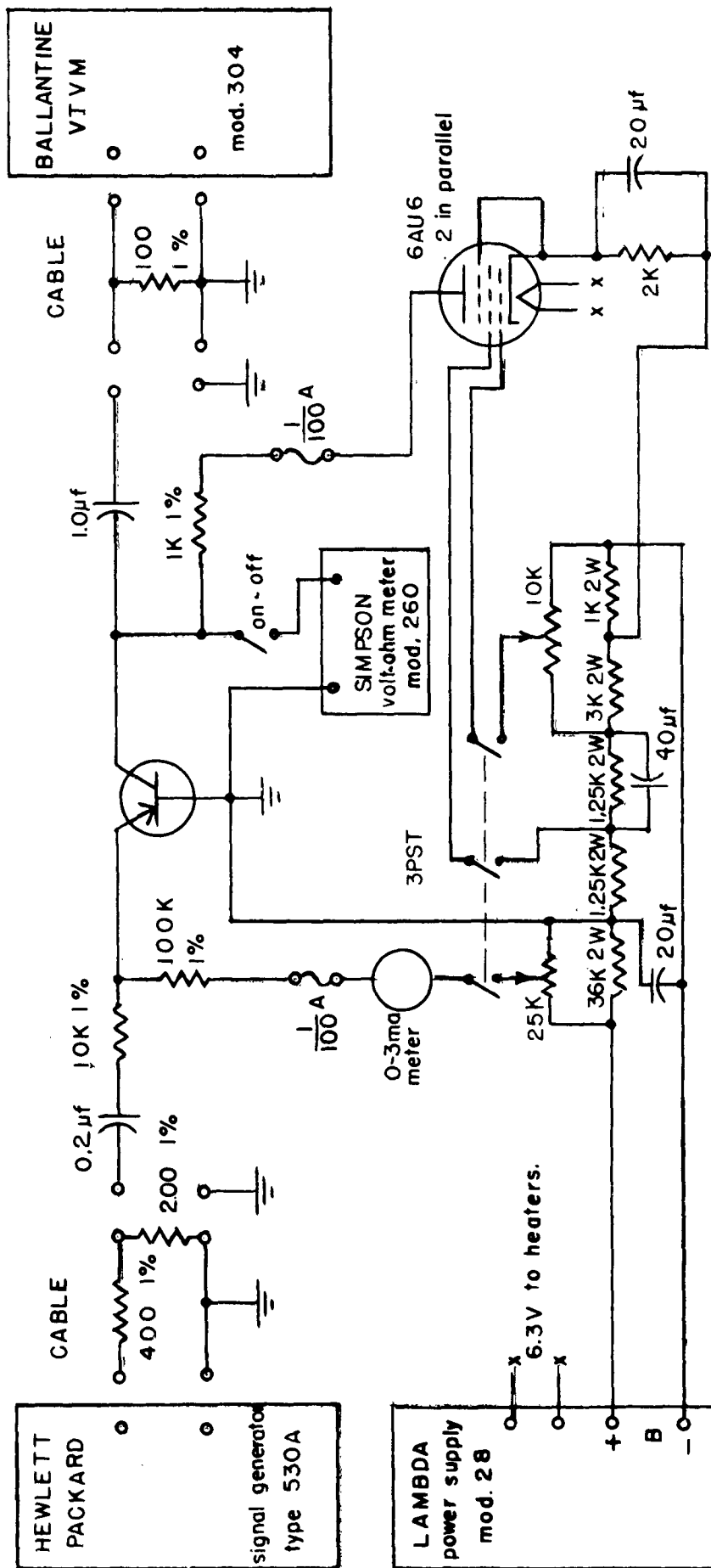

FIG. 16. SCHEMATIC DIAGRAM OF TRANSISTOR CUT-OFF-FREQUENCY MEASURING EQUIPMENT.

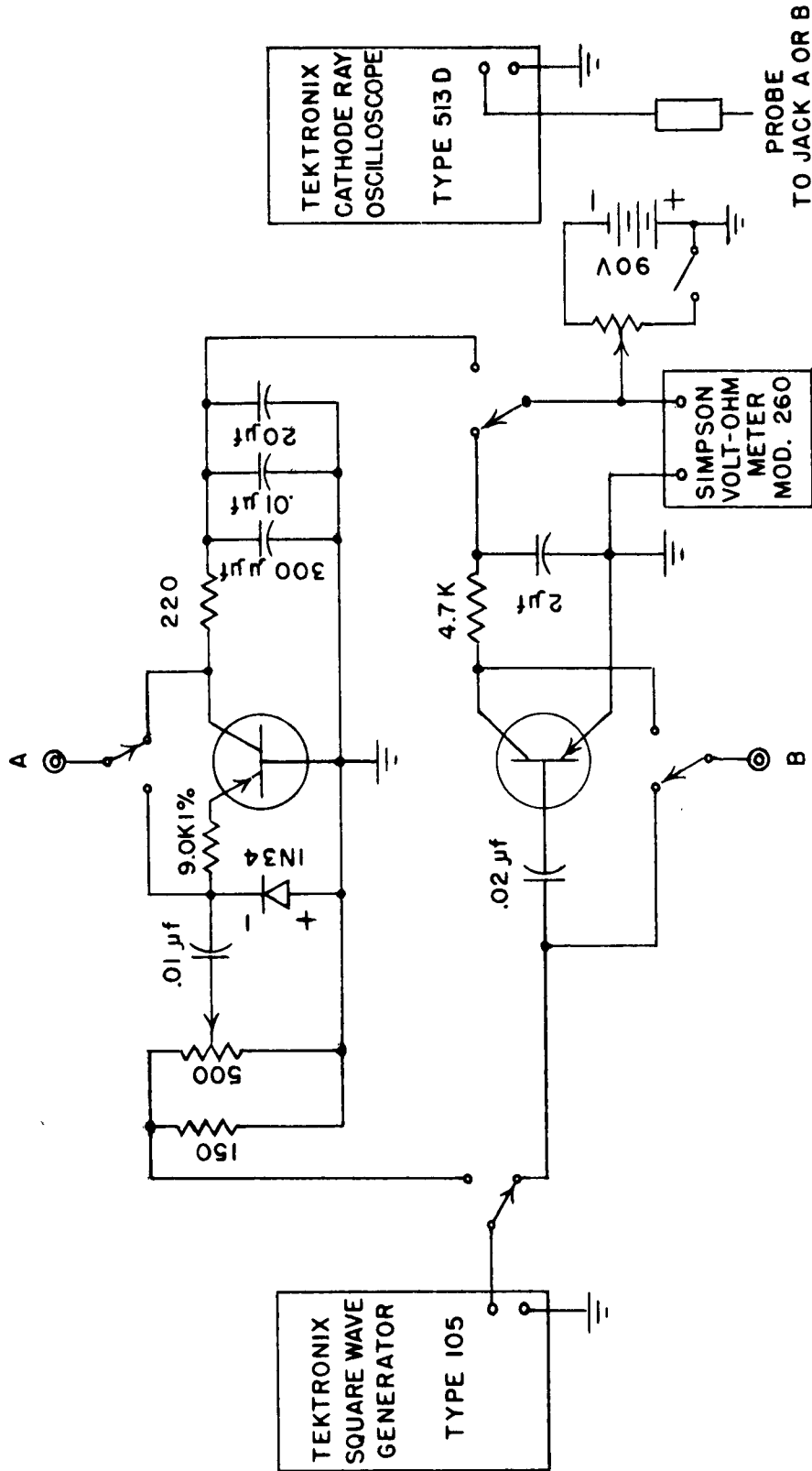

FIG. 17. SCHEMATIC DIAGRAM OF LARGE SIGNAL AND HOLE-STORAGE TIME TRANSISTOR TESTING EQUIPMENT.

b. Bibliography

1. Bartram, J. F. "Progress Report on Pulse Shape Studies", Yale University, Dunham Lab., Conn., Tech. Report No. 1, USA Contract No. DA-36-039-sc-5416 (November 13, 1951)
2. Boothroyd and Creamer "A Time-Division Multiplexing System", AIEE Technical Paper 49-25 (December, 1948)
3. Wiener, N. and Lee, Y.W., US Patent No. 2,024,900 (December 17, 1935)
4. Levy, M. "The Impulse Response of Electrical Networks", Jour. Inst. of Elect. Eng., (Repr.), 90, III (Comm. Eng.), No. 12 (December 1943)
5. Stutt, C. A. "Experimental Study of Optimum Filters", Research Lab. of Electronics, M.I.T., Cambridge, Mass., Technical Rept. 182 (May, 1951)
6. Ryde, J. W. and Ryde, D. "Attenuation of Centimetre and Millimetre Waves by Rain, Hail, Fogs, and Clouds", Report No. 8670, Res. Lab. of G. E. Co., Ltd., Wembley, England. (May, 1945)
7. Wexler, R. and Weinstein, J. "Rainfall Intensities and Attenuation of Centimeter Electromagnetic Waves", Proc. I.R.E., pp. 353-5. (March, 1948)
8. Foster, E. E. Rainfall and Runoff, New York, 1948, The MacMillan Company
9. Kerr, D. E. Propogation of Short Radio Waves, Radiation Lab. Series, Vol. 13, McGraw-Hill Book Co., Inc., New York, N.Y. (1951)
10. "Proposal for a New IFF System", USNEL Rept. 3 DPS Index No. 207-101, Buships Problem D1903S (Secret) 18 Apr 47