

THIS REPORT HAS BEEN DECLASSIFIED
AND CLEARED FOR PUBLIC RELEASE.

DISTRIBUTION A
APPROVED FOR PUBLIC RELEASE;
DISTRIBUTION UNLIMITED.

UNCLASSIFIED

AD _____

DEFENSE DOCUMENTATION CENTER

FOR

SCIENTIFIC AND TECHNICAL INFORMATION

CAMERON STATION ALEXANDRIA, VIRGINIA

DOWNGRADED AT 3 YEAR INTERVALS:
DECLASSIFIED AFTER 12 YEARS
DCD DIR 5200 10



UNCLASSIFIED

STRESS CONCENTRATION DUE TO A HEMISPHERICAL PIT
AT A FREE SURFACE

By

R. A. Eubanks

AD NO. 5650
ASTIA FILE COPY

A Technical Report to the

Office of Naval Research
Department of the Navy
Washington, D. C.

Contract N7onr-32906

Project No. NR 035-302

Department of Mechanics
Illinois Institute of Technology
Chicago, Illinois

January 1, 1953

STRESS CONCENTRATION DUE TO A HEMISPHERICAL PIT
AT A FREE SURFACE

By

R. A. Eubanks

A Technical Report to the

Office of Naval Research
Department of the Navy
Washington, D. C.

Contract N7onr-32906

Project No. NR 035-302

Department of Mechanics
Illinois Institute of Technology
Chicago, Illinois

January 1, 1953

2130069

327 - N7onr 32906.

see sec.

2''

SUMMARY

This paper contains a solution in series form for the stresses and displacements around a hemispherical pit at a free surface of an elastic body. The problem is idealized by considering a semi-infinite medium which is otherwise bounded by a plane. At infinity the body is assumed to be in a state of plane hydrostatic tension perpendicular to the axis of symmetry of the pit. The present method of solution may be generalized to loadings which are not rotationally symmetric. Numerical results are given for the variation along the axis of symmetry of the normal stress which is parallel to the tractions at infinity; these results are compared with the known corresponding numerical values appropriate to the two-dimensional analog of the present problem.

TABLE OF CONTENTS

	Page
PREFACE	iv
LIST OF TABLES	v
LIST OF ILLUSTRATIONS	v
SECTION	
I. INTRODUCTION, STATEMENT OF PROBLEM	1
II. PARTICULAR SOLUTIONS IN SPHERICAL COORDINATES	5
III. SOLUTION OF PROBLEM	13
IV. STRESS EVALUATIONS, ACCELERATION OF CONVERGENCE, NUMERICAL RESULTS	17
BIBLIOGRAPHY	24

PREFACE

The author is greatly indebted to Dr. E. Sternberg for invaluable advice and guidance in this investigation. Thanks are also due to Dr. M. A. Sadowsky for helpful suggestions. The assistance of Messrs. S. Parter, K. Fukuda, and W. P. Darsow in voluminous numerical computations is gratefully acknowledged.

LIST OF TABLES

Table		Page
1.	Numerical Values of c_n for $\nu = 1/4$	17
2.	The Stress σ_θ for $p = 1, \nu = 1/4$	22

LIST OF ILLUSTRATIONS

Figure		Page
1.	Meridional Cross Section of Pitted Region, Spherical Coordinates	2
2.	Decay of the Maximum Stress σ_θ along the Axis of Symmetry. $\sigma_x = \sigma_y = 1$ at Infinity.	23

STRESS CONCENTRATION DUE TO A HEMISPHERICAL PIT
AT A FREE SURFACE

I. INTRODUCTION, STATEMENT OF PROBLEM

In what follows we investigate the stress concentration produced by a hemispherical pit at a free surface of an elastic body. The problem is idealized by considering the medium to occupy a semi-infinite region containing a hemispherical indentation and otherwise bounded by a plane. With reference to cartesian coordinates (x, y, z) , the region under consideration (Figure 1) is defined by $z \geq 0$, $r = (x^2 + y^2 + z^2)^{1/2} \geq 1$ if, for the sake of convenience, we assume the pit to have a radius of unity.

The body forces are assumed to vanish. So far as the loading is concerned, we confine ourselves to the axisymmetric case in which the tractions at infinity constitute a plane hydrostatic field of stress parallel to the plane $z = 0$. It should be emphasized, however, that the method of solution adopted subsequently may be extended to the case in which the plane stress field at infinity is no longer rotationally symmetric. In the present instance, the boundary conditions at infinity assume the form,

$$\sigma_x, \sigma_y \rightarrow 1, \quad \sigma_z, \tau_{xy}, \tau_{yz}, \tau_{zx} \rightarrow 0 \quad \text{as } r \rightarrow \infty, \quad (1)$$

where $(\sigma_x, \dots, \tau_{xy}, \dots)$ are the cartesian components of stress. With reference to spherical coordinates (r, θ, γ) , introduced by the mapping,

$$\left. \begin{aligned} x &= r \sin \theta \cos \gamma, \\ y &= r \sin \theta \sin \gamma, \\ z &= r \cos \theta, \\ 0 \leq r < \infty, \quad 0 \leq \theta \leq \pi, \quad 0 \leq \gamma \leq 2\pi, \end{aligned} \right\} \quad (2)$$

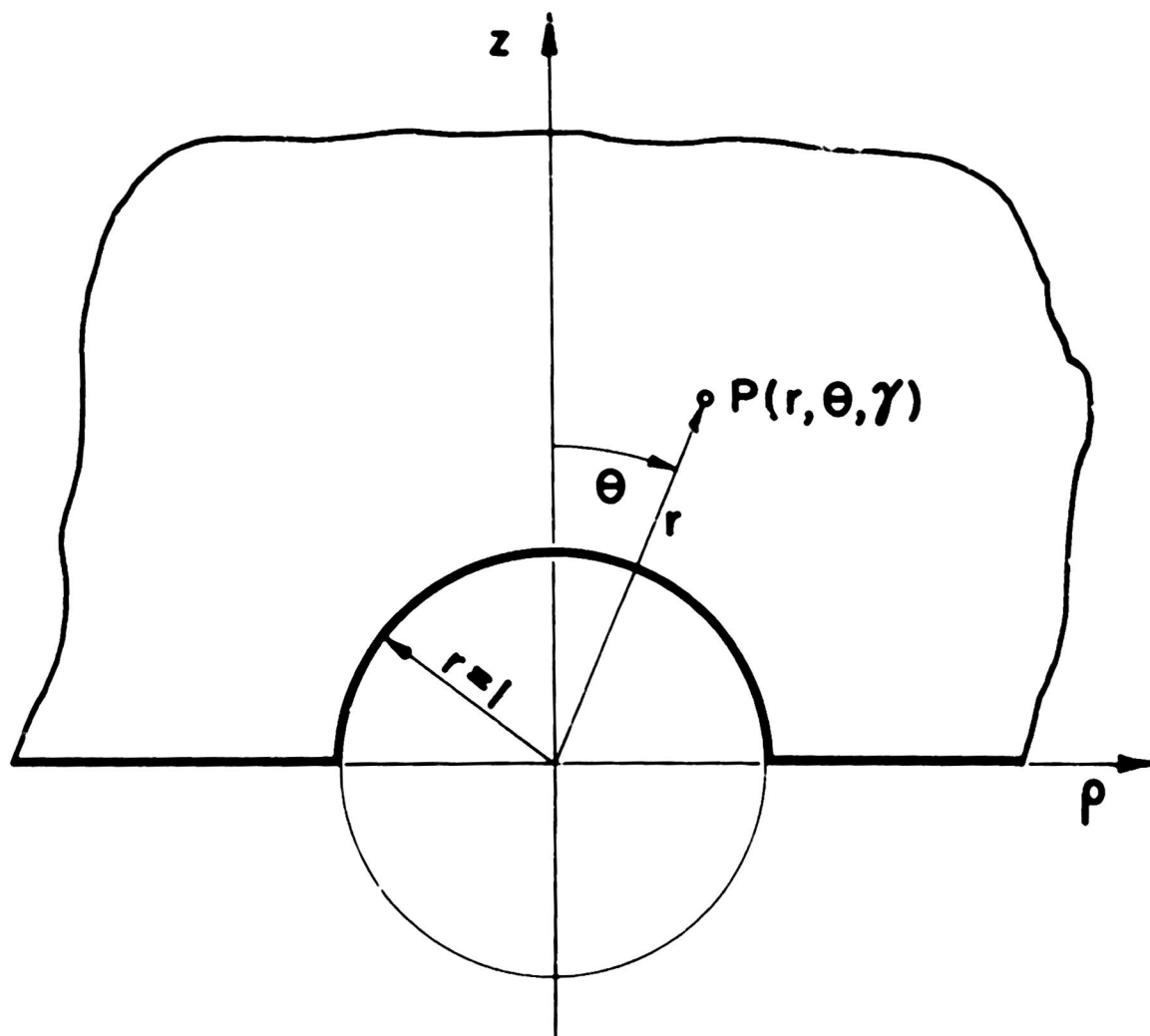

Figure 1
Meridional Cross-Section of the Pitted Region,
Spherical Coordinates

the conditions to be met at the stress-free plane boundary appear as

$$\left. \begin{aligned} \sigma_{\theta} = \tau_{r\theta} = \tau_{\theta y} = 0 \\ \text{for } 1 \leq r < \infty, \quad \theta = \pi/2, \quad 0 \leq y \leq 2\pi, \end{aligned} \right\} \quad (3)$$

whereas a traction-free surface of the pit requires

$$\left. \begin{aligned} \sigma_r = \tau_{r\theta} = \tau_{ry} = 0 \\ \text{for } r = 1, \quad 0 \leq \theta \leq \pi/2, \quad 0 \leq y \leq 2\pi, \end{aligned} \right\} \quad (4)$$

in which $(\sigma_r, \dots, \tau_{r\theta}, \dots)$ are the spherical components of stress.

The two-dimensional analog of this problem, that is, the problem presented by the stress concentration around a semi-circular notch in a semi-infinite plate which, at infinity, is in a state of uniaxial tension parallel to its straight edge, has received repeated attention. Maunsell [1]¹ obtained a series solution to this plane problem by first extending the uniform stress field at infinity throughout the half-plane and then removing the tractions so arising on the notch with the aid of a doubly infinite sequence of particular solutions of the field equations. This sequence is constructed in such a manner that each of its members is singular at the center of the notch, and leaves the straight boundary, as well as infinity, free from tractions. Subsequently, Weinel [2] and C. B. Ling [3], using bipolar coordinates, arrived at more elegant integral representations of the solution to the plane problem. The application to the present space problem of analogous integral approaches, based

¹Numbers in brackets refer to the bibliography at the end of this paper.

on the use of toroidal coordinates, meets with great analytical difficulties.² The method of solution adopted here may be regarded as the three-dimensional counterpart of that employed by Maunsell [1].

²One is led to a system of dual integral equations the kernels of which involve the Legendre functions of the first kind of complex index, $P_{-1/2+it}(q)$, where the index parameter t is the variable of integration. These functions have not been investigated extensively; see [4], p. 451.

II. PARTICULAR SOLUTIONS IN SPHERICAL COORDINATES

The problem characterized by the boundary conditions (1), (3), and (4), may be attacked by any one of the various available stress-function approaches to axisymmetric problems in elasticity theory.³ We shall utilize the approach originated by Boussinesq [7], according to which the general solution of the displacement equations of equilibrium, in case of torsion-free rotational symmetry, and in the absence of body forces, is representable as the sum of the two displacement fields,

$$2G [u_x, u_y, u_z] = \text{grad } \phi, \quad (5)$$

$$2G [u_x, u_y, u_z] = \text{grad } (z \psi) - 4(1 - \nu) [0, 0, \psi], \quad (6)$$

where

$$\nabla^2 \phi(r, z) = 0, \quad \nabla^2 \psi(r, z) = 0. \quad (7)$$

Here u_x, u_y, u_z are cartesian components of displacement, $r = (x^2 + y^2 + z^2)^{1/2}$, ∇^2 is the Laplace operator, and G and ν are the shear modulus and Poisson's ratio, respectively.

For our present purposes it is expedient to refer to the spherical coordinates (r, θ, γ) defined by Equations (2). The basic displacement fields given in Equations (5), (6), and their associated fields of stress, were transformed into general orthogonal axisymmetric coordinates in [6]. The specific forms assumed by the Boussinesq solutions in spherical coordinates appear explicitly in [8], which also contains the particular solutions obtained upon introduction of the interior and exterior spherical harmonics of integral order as generating stress functions ϕ and ψ .

³See [5], Chapter VIII, and [6] for references.

In view of the regularity requirements inherent in the current problem, we limit our attention to the two aggregates of harmonic stress functions,

$$\left. \begin{aligned} \phi_n(r, \Theta) &= r^{-n-1} P_n(\cos \Theta) \\ \psi_n(r, \Theta) &= r^{-n-1} P_n(\cos \Theta) \end{aligned} \right\} \quad (8)$$

$$(n = 0, 1, 2, \dots),$$

in which P_n denotes the Legendre polynomial of order n . The stress functions defined in Equations (8) represent exterior spherical harmonics and give rise to displacement and stress fields which are singular at the origin $r = 0$, are otherwise regular, and vanish at infinity. The particular solutions of the field equations generated by ϕ_n and ψ_n will be designated by $[A_n]$ and $[C_n]$, respectively. As explained in [8], considerable simplifications arise from a replacement of solution $[C_n]$ with the linear combination,

$$[B_n] = (2n + 1) [C_n] - (n + 4 - 4\nu) [A_{n-1}]. \quad (9)^4$$

We now cite⁵ the displacement and stress fields appropriate to solutions $[A_n]$ and $[B_n]$. With the auxiliary notations,

$$p = \cos \Theta, \quad \bar{p} = \sin \Theta, \quad (10)$$

we obtain for solution $[A_n]$,

$$2Gu_r = -\frac{(n+1)P_n}{r^{n+2}}, \quad 2Gu_\Theta = -\frac{\bar{p}P_n'}{r^{n+2}}, \quad (11)^6$$

⁴In Equation (9), as in subsequent equations, the letters in brackets denote either the displacement vector field or the stress tensor field, and equality, addition, as well as multiplication by a scalar, are to be interpreted accordingly.

⁵See Equations (12), (13), (17), (18) of [6].

⁶The argument of P_n is henceforth understood to be p and $P_n' \equiv \frac{dP_n}{dp}$.

$$\left. \begin{aligned}
 \sigma_r &= \frac{(n+1)(n+2)}{r^{n+3}} P_n, \\
 \sigma_\theta &= \frac{1}{r^{n+3}} \left[P'_{n+1} - (n+1)(n+2) P_n \right], \\
 \sigma_y &= -\frac{P'_{n+1}}{r^{n+3}}, \quad \tau_{r\theta} = \frac{n+2}{r^{n+3}} \bar{p} P'_n.
 \end{aligned} \right\} (12)$$

On the other hand, for $[B_n]$ there results

$$\left. \begin{aligned}
 2Gu_r &= -\frac{(n+1)(n+4-4\nu)}{r^{n+1}} P_{n+1} \\
 2Gu_\theta &= -\bar{p} \frac{(n-3+4\nu)}{r^{n+1}} P'_{n+1},
 \end{aligned} \right\} (13)$$

$$\left. \begin{aligned}
 \sigma_r &= (n+1) \left[(n+1)(n+4) - 2\nu \right] \frac{P_{n+1}}{r^{n+2}} \\
 \sigma_\theta &= \frac{-1}{r^{n+2}} \left[(n+1)(n^2 - n + 1 - 2\nu) P_{n+1} - (n-3+4\nu) P'_n \right] \\
 \sigma_y &= \frac{-1}{r^{n+2}} \left[(1-2\nu)(n+1)(2n+1) P_{n+1} + (n-3+4\nu) P'_n \right] \\
 \tau_{r\theta} &= (n^2 + 2n - 1 + 2\nu) \bar{p} \frac{P'_{n+1}}{r^{n+2}}.
 \end{aligned} \right\} (14)$$

In the preceding equations u_r , u_θ and σ_r , σ_θ , σ_y , $\tau_{r\theta}$ denote spherical components of displacement and stress, respectively; the displacement of u_y and the stresses τ_{yr} , $\tau_{y\theta}$, which vanish identically by virtue of rotational symmetry, have been omitted.

The physical significance of the sequences of solutions $[A_n]$, $[B_n]$, ($n = 0, 1, 2, \dots$), was examined in Reference [8]. Solution $[A_0]$ may be identified as that appropriate to a center of compression at the origin, whereas $[B_0]$ is the solution corresponding to a concentrated force acting at $r = 0$ in an infinite body, in the direction of the

negative z -axis.⁷ Moreover, in cartesian coordinates,

$$\left. \begin{aligned} [A_n] &= \frac{(-1)^n}{[n]} \frac{\partial^n}{\partial z^n} [A_0], \\ [B_n] &= \frac{(-1)^n(2n+1)}{[n]} \frac{\partial^n}{\partial z^n} [B_0] + (n-3+4\nu) [A_{n-1}], \end{aligned} \right\} (15)$$

($n = 1, 2, 3, \dots$).

Hence, these two aggregates represent sequences of successively higher singularities which may be obtained by suitable limit processes applied to the basic axisymmetric singularities corresponding to solutions $[A_0]$ and $[B_0]$. In particular, $[B_1]$ represents a force doublet along the z -axis together with a center of compression, both located at the origin. We note that solutions $[A_n]$ ($n = 0, 1, 2, \dots$), and $[B_n]$ ($n = 1, 2, 3, \dots$), are self-equilibrated in the sense that the associated tractions on any closed surface surrounding the origin are statically equivalent to null.

In the specific problem to be treated presently we need to construct particular solutions which leave the plane $z = 0$ ($p = 0$) free from surface tractions. To this end, we recall that

$$P_{2n+1}(0) = 0, \quad P'_{2n}(0) = 0, \quad (n = 0, 1, 2, \dots). \quad (16)$$

Furthermore, Equations (16), by virtue of the Legendre recurrence relations,

$$\left. \begin{aligned} (2n+1)p P_n &= (n+1) P_{n+1} + n P_{n-1}, \\ p^2 P'_n &= n P_{n-1} - np P_n, \end{aligned} \right\} (17)$$

imply

⁷ See [9], pp. 185-187.

$$\begin{aligned}
 P'_{2n+1}(0) &= (2n+1) P_{2n}(0) \\
 P_{2n+2}(0) &= -\frac{2n+1}{2n+2} P_{2n}(0) \\
 P_{2n}(0) &= (-1)^n \frac{\lfloor 2n \rfloor}{2^{2n} (\lfloor n \rfloor)^2} \\
 (n &= 0, 1, 2, \dots).
 \end{aligned}
 \tag{18}$$

Substitution of (16), (18) into (12), (14) thus yields for the normal and shearing stresses of solutions $[A_n]$ and $[B_n]$, on the plane $p = 0$, the following values:

For solution $[A_{2n}]$,

$$\sigma_{\Theta} = -\frac{(2n+1)^2}{r^{2n+3}} P_{2n}(0), \quad \tau_{r\Theta} = 0; \tag{19}$$

for solution $[A_{2n+1}]$,

$$\sigma_{\Theta} = 0, \quad \tau_{r\Theta} = \frac{(2n+1)(2n+3)}{r^{2n+4}} P_{2n}(0); \tag{20}$$

for solution $[B_{2n+1}]$,

$$\sigma_{\Theta} = \frac{(2n+1)(4n^2 + 4n - 1 + 2\nu)}{r^{2n+3}} P_{2n}(0), \quad \tau_{r\Theta} = 0; \tag{21}$$

for solution $[B_{2n+2}]$,

$$\sigma_{\Theta} = 0, \quad \tau_{r\Theta} = -\frac{(2n+1)(2n+3)(4n^2 + 12n + 7 + 2\nu)}{(2n+2) r^{2n+4}} P_{2n}(0). \tag{22}$$

In view of Equations (19) to (22), it is clear that the linear combinations,

$$\begin{aligned}
 [D_n] &= \alpha_{2n} [A_{2n}] + (2n+1) [B_{2n+1}] \\
 [E_n] &= \alpha_{2n+2} [A_{2n+1}] + (2n+2) [B_{2n+2}] \\
 (n &= 0, 1, 2, \dots),
 \end{aligned}
 \tag{23}$$

where

$$\alpha_{2n} \equiv (2n + 1)^2 - 2 + 2\nu, \quad (24)$$

satisfy Equations (3), that is, clear the plane $z = 0$ from tractions.

From Equations (11), (12), (13), (14), we obtain for $[D_n]$,

$$\left. \begin{aligned} 2Gu_r &= -\frac{2n+1}{r^{2n+2}} \left[\alpha_{2n} P_{2n} + (2n+2)(2n+5-4\nu) P_{2n+2} \right] \\ 2Gu_\theta &= -\frac{\bar{p}}{r^{2n+2}} \left[\alpha_{2n} P'_{2n} + (2n-2+4\nu)(2n+1) P'_{2n+2} \right] \end{aligned} \right\} (25)$$

$$\left. \begin{aligned} \sigma_r &= \frac{(2n+1)(2n+2)}{r^{2n+3}} \left[\alpha_{2n} P_{2n} + \beta_{2n} P_{2n+2} \right] \\ \sigma_\theta &= \frac{1}{r^{2n+3}} \left\{ \left[\alpha_{2n} + (2n+1)(2n-2+4\nu) \right] P'_{2n+1} \right. \\ &\quad \left. - (2n+1)(2n+2) \left[\alpha_{2n} P_{2n} + (\alpha_{2n} - 2n + 2 - 4\nu) P_{2n+2} \right] \right\} \\ \sigma_y &= -\frac{4n+3}{r^{2n+3}} \left[(2n+1)(2n+2)(1-2\nu) P_{2n+2} \right. \\ &\quad \left. + (2n-1+2\nu) P'_{2n+1} \right] \\ \tau_{r\theta} &= \frac{\bar{p}}{r^{2n+3}} \left[(2n+2) \alpha_{2n} P'_{2n} + (2n+1) \alpha_{2n+1} P'_{2n+2} \right], \end{aligned} \right\} (26)$$

and for $[E_n]$,

$$\left. \begin{aligned} 2Gu_r &= -\frac{2n+2}{r^{2n+3}} \left[\alpha_{2n+2} P_{2n+1} + (2n+3)(2n+6-4\nu) P_{2n+3} \right] \\ 2Gu_\theta &= -\frac{\bar{p}}{r^{2n+3}} \left[\alpha_{2n+2} P'_{2n+1} + (2n+2)(2n-1+4\nu) P'_{2n+3} \right] \end{aligned} \right\} (27)$$

$$\begin{aligned}
 \sigma_r &= \frac{(2n+2)(2n+3)}{r^{2n+4}} \left[\alpha_{2n+2} P_{2n+1} + \beta_{2n+1} P_{2n+3} \right] \\
 \sigma_\theta &= \frac{1}{r^{2n+4}} \left\{ \left[\alpha_{2n+2} + (2n+2)(2n-1+4\nu) \right] P'_{2n+2} \right. \\
 &\quad \left. - (2n+2)(2n+3) \left[\alpha_{2n+2} P_{2n+1} \right. \right. \\
 &\quad \left. \left. + (\alpha_{2n+1} - 2n+1-4\nu) P_{2n+3} \right] \right\} \\
 \sigma_y &= -\frac{4n+5}{r^{2n+4}} \left[(2n+1+2\nu) P'_{2n+2} \right. \\
 &\quad \left. + (1-2\nu)(2n+2)(2n+3) P_{2n+3} \right] \\
 \tau_{r\theta} &= \frac{\bar{p}}{r^{2n+4}} \alpha_{2n+2} \left[(2n+2) P'_{2n+3} + (2n+3) P'_{2n+1} \right],
 \end{aligned} \tag{28}$$

where

$$\beta_n \equiv (n+2)(n+5) - 2\nu. \tag{29}$$

Solutions $[D_n]$ and $[E_n]$ are self-equilibrated in the upper half-space, in the sense that the resultant of the corresponding tractions vanishes on a hemisphere centered at $r=0$ and lying in the region $z \geq 0$. To show this, we observe that for any axisymmetric stress field this resultant is a single force coincident with the z -axis, the magnitude of which is given by

$$Z(r) = -2\pi r^2 \int_0^1 \left[p\sigma_r - \bar{p} \tau_{r\theta} \right] dp, \tag{30}$$

where $Z(r)$ is positive if its sense is that of the positive z -axis. Equation (30), after a trivial computation, yields for the first Boussinesq solution, defined by Equation (5),

$$Z(r) = 2\pi r \left. \frac{\partial \phi}{\partial r} \right|_{p=0}, \tag{31}$$

whereas for the second Boussinesq solution, defined by Equation (6), we reach

$$Z(r) = 4\pi(1 - \nu)r^2 \int_0^1 \frac{\partial \psi}{\partial r} dp. \quad (32)$$

Equations (31), (32), together with (8), (9), (23), (24), confirm the self-equilibrance in the upper half-space of $[D_n]$, $[E_n]$. We note that self-equilibrance, in the present sense, is not a necessary consequence of the requirement that the tractions of a solution be zero on the plane $p = 0$, with the exception of the origin. The well known solution of Boussinesq corresponding to a concentrated normal load on the half-space⁸ conforms to this requirement but is, evidently, not self-equilibrated.

The physical significance of the singular solutions $[D_n]$, $[E_n]$ can be exhibited readily. For example, $[D_0]$ corresponds⁹ to two mutually perpendicular tangential force doublets, acting at the origin, on the plane $p = 0$. The physical significance of the other members of these two aggregates can, similarly, be established through suitable limit processes applied to the solutions corresponding to various configurations of normal and tangential forces acting on the plane boundary of the half-space.

⁸See [9], p. 191.

⁹See [10].

III. SOLUTION OF PROBLEM

We assume the solution [S] to the problem characterized by the boundary conditions (1), (3), (4) in the form,

$$[S] = [U] + [R]. \quad (33)$$

Solution [U] corresponds to the uniform stress field,

$$\sigma_x = \sigma_y = 1, \quad \sigma_z = \tau_{xy} = \tau_{yz} = \tau_{zx} = 0, \quad (34)$$

or, with reference to spherical coordinates, to

$$\left. \begin{aligned} \sigma_r &= \bar{p}^2, & \sigma_\theta &= p^2, \\ \sigma_\gamma &= 1, & \tau_{r\theta} &= \bar{p}p, \end{aligned} \right\} (35)^{10}$$

where p, \bar{p} are defined in Equations (10), while [R] is the solution to the "residual" problem, the definition of which is implicit in Equation (33). Thus, [R] is characterized by the boundary conditions (3), in addition to the requirement,

$$\sigma_r, \sigma_\theta, \sigma_\gamma, \tau_{r\theta} \rightarrow 0 \text{ as } r \rightarrow \infty, \quad (36)^{10}$$

and must satisfy

$$\left. \begin{aligned} \sigma_r &= -\bar{p}^2, & \tau_{r\theta} &= -\bar{p}p, \\ \text{for } r &= 1, \quad 0 \leq p \leq 1, & 0 \leq \gamma &\leq 2\pi. \end{aligned} \right\} (37)$$

¹⁰The stresses $\tau_{\gamma r}$ and $\tau_{\gamma\theta}$ are zero by virtue of rotational symmetry and have been omitted.

The tractions of $[R]$ on the surface of the pit have zero resultant. Since, furthermore, $[R]$ must leave the surface $1 \leq r < \infty$, $p = 0$ free from tractions, we are led to expand $[R]$ in terms of the two aggregates of solutions $[D_n]$, $[E_n]$, Equations (23) to (29), which possess both of these properties. Thus, we assume

$$[R] = \sum_{n=0}^{\infty} \left\{ a_n [D_n] + b_n [E_n] \right\}, \quad (38)$$

where a_n, b_n ($n = 0, 1, 2, \dots$) are, as yet, arbitrary.

In view of the fact that each $[D_n], [E_n]$ ($n = 0, 1, 2, \dots$) satisfies the boundary conditions (3), (36), the same is true of $[R]$ provided the series in Equation (38) converge suitably. With a view toward meeting the boundary conditions (37), we observe that they may be written as

$$\left. \begin{aligned} \sigma_r &= -\frac{2}{3} P_0 + \frac{2}{3} P_2, & \tau_{r\theta} &= -\frac{1}{3} \bar{p} P_2', \\ \text{for } r &= 1, 0 \leq p \leq 1, 0 \leq \gamma \leq 2\pi. \end{aligned} \right\} \quad (39)$$

Furthermore, the expansions,¹¹

$$\left. \begin{aligned} P_{2k+1}(p) &= (2k+1) P_{2k}(0) \sum_{n=0}^{\infty} \omega_k^{(n)} P_{2n}(p), \\ P_{2k+1}'(p) &= (2k+1) P_{2k}(0) \sum_{n=0}^{\infty} \omega_k^{(n)} P_{2n}'(p), \\ \omega_k^{(n)} &= \frac{(4n+1) P_{2n}(0)}{(2k+1-2n)(2k+2+2n)}, \quad 0 < p \leq 1, \end{aligned} \right\} \quad (40)$$

with the aid of Equations (28), lead to the following Legendre series representation of $\sigma_r, \tau_{r\theta}$ of $[E_k]$ on $r = 1, 0 \leq p \leq 1$,

¹¹See, for example, [4], pp. 38, 39.

$$\left. \begin{aligned}
 \sigma_r &= (2k+1)(2k+3)P_{2k}(0) \sum_{n=0}^{\infty} \left[(2k+2)\alpha_{2k+2} \omega_k^{(n)} \right. \\
 &\quad \left. - (2k+3)\beta_{2k+1} \omega_{k+1}^{(n)} \right] P_{2n}(p), \\
 \tau_{r\theta} &= (2k+1)(2k+3)P_{2k}(0) \alpha_{2k+2} \bar{p} \sum_{n=1}^{\infty} \left[\omega_k^{(n)} - \omega_{k+1}^{(n)} \right] P'_{2n}(p), \\
 &\text{for } r=1, \quad 0 \leq p \leq 1, \quad 0 \leq \gamma \leq 2\pi.
 \end{aligned} \right\} (41)^{12}$$

Application of the boundary conditions (37) to [R] in Equation (38), by aid of Equations (26) and (41), yields a doubly infinite system of equations for the coefficients of superposition a_n, b_n ($n = 0, 1, 2, \dots$).

These equations are equivalent to the following set:

$$\left. \begin{aligned}
 a_{n-1} &= \frac{(2n+2)\alpha_{2n}}{\Delta_n} \left[\frac{5}{3} \delta_1^{(n)} + \sum_{k=0}^{\infty} \left\{ (2n-2k-1)\alpha_{2k+2} \omega_k^{(n)} \right. \right. \\
 &\quad \left. \left. + \left[(2k+3)\beta_{2k+1} - (2n+1)\alpha_{2k+2} \right] \omega_{k+1}^{(n)} \right\} c_k \right] \\
 &\quad (n = 1, 2, 3, \dots), \\
 a_n &= \frac{(2n-1)}{\Delta_n} \left[\frac{2}{3} \delta_0^{(n)} - 8\delta_1^{(n)} + \sum_{k=0}^{\infty} \left\{ \left[(2k+2)\alpha_{2n-1} \right. \right. \right. \\
 &\quad \left. \left. - 2n\beta_{2n-2} \right] \alpha_{2k+2} \omega_k^{(n)} \right. \\
 &\quad \left. \left. + \left[2n\beta_{2n-2} \alpha_{2k+2} - (2k+3)\alpha_{2n-1} \beta_{2k+1} \right] \omega_{k+1}^{(n)} \right\} c_k \right] \\
 &\quad (n = 0, 1, 2, \dots),
 \end{aligned} \right\} (42)$$

¹²Note that although Equations (40) hold only for the open interval $0 < p \leq 1$, Equations (41) are valid for the closed interval since $\tau_{r\theta}$ of [E_k] vanishes for $p = 0$.

where $\delta_m^{(n)}$ is the Kronecker delta and

$$\left. \begin{aligned} c_k &= (2k+1)(2k+3) P_{2k}^{(0)} b_k, & \alpha_{-1} &= 1, \\ \Delta_n &= (2n-1)(2n+2) \alpha_{2n} \left[2n \beta_{2n-2} - (2n+1) \alpha_{2n-1} \right]. \end{aligned} \right\} (43)$$

The elimination of a_n between the two systems of equations given in Equations (42) yields an infinite system of equations for the unknowns c_k ($k = 0, 1, 2, \dots$). Since these equations are at once obtainable from Equations (42), they may be omitted here. Once the c_k have been determined, the coefficients of superposition a_n, b_n follow from Equations (42), (43). The values of these coefficients, together with Equations (24) to (29), (33), (35), (38), constitute the complete solution of the problem.

IV. STRESS EVALUATIONS, ACCELERATION OF CONVERGENCE, NUMERICAL RESULTS

The infinite system of equations for the c_k , which is immediate from Equations (42), was dealt with by the usual segmentation process, for $\nu = \frac{1}{4}$. Thus, systems of n equations in n unknowns, which correspond to principle sub-matrices of rank n , were solved for values of n ranging from 10 to 26. The systems of equations for $n = 25$ and $n = 26$ yield coefficients c_k which agree to the number of figures shown in Table 1. These values were used in the subsequent stress computations.

Table 1. Numerical Values of c_n for $\nu = 1/4$.

n	c_n
0	- 0.158,199,1
1	0.046,745,3
2	0.006,036,9
3	0.001,551,8
4	0.000,491,7
5	0.000,163,5
6	0.000,047,3

The series, Equations (42), for a_n , converge slowly and, consequently, the same applies to the series for the individual stress components. For the purpose of accelerating the convergence, the following method of stress computation was adopted: Let $s_n(r, \theta)$ be a representative stress component of $[D_n]$. If the first of Equations (42) is written in the form,

$$a_{n-1} = f_n + \sum_{k=0}^{\infty} g_n^{(k)} c_k, \quad (n = 1, 2, 3, \dots), \quad (44)$$

the corresponding representative stress component $s(r, \Theta)$ of

$\sum_{n=1}^{\infty} a_{n-1} [D_{n-1}]$ becomes

$$\begin{aligned}
 s &= \sum_{n=1}^{\infty} a_{n-1} s_{n-1} \\
 &= \sum_{n=1}^{\infty} \left[f_n + \sum_{k=0}^{\infty} g_n^{(k)} c_k \right] s_{n-1} \\
 &= \sum_{n=1}^{\infty} f_n s_{n-1} + \sum_{k=0}^{\infty} \left[\sum_{n=1}^{\infty} g_n^{(k)} s_{n-1} \right] c_k.
 \end{aligned} \tag{45}$$

The slow convergence of the double series in Equations (45) is readily traced to the slow convergence of the series,

$$q^{(k)} = \sum_{n=1}^{\infty} g_n^{(k)} s_{n-1}. \tag{46}$$

Since the general term in the series for $q^{(k)}$ is available from Equations (26), (42), (44), Kummer's transformation¹³ can be used to accelerate the convergence. Thus, a sequence of functions $h_n^{(k)}(r, \Theta)$ is determined such that

$$\lim_{n \rightarrow \infty} \frac{g_n^{(k)} s_{n-1}}{h_n^{(k)}} = 1, \quad (k = 0, 1, 2, \dots), \tag{47}$$

and

$$H^{(k)} = \sum_{n=1}^{\infty} h_n^{(k)} \tag{48}$$

admits a closed representation. One then has

$$q^{(k)} = H^{(k)} + \sum_{n=1}^{\infty} \left[g_n^{(k)} s_{n-1} - h_n^{(k)} \right]. \tag{49}$$

¹³See, for example, [11], p. 247.

The series in Equation (49) converges faster than that in Equation (46).

We illustrate the foregoing procedure with the stress component σ_{θ} , on the axis of symmetry, which is of primary interest in the present investigation. Thus, let s in the preceding discussion be σ_{θ} for $p = 1$. Since

$$P_n(1) = 1, \quad P_n'(1) = \frac{n(n+1)}{2}, \quad (n = 0, 1, 2, \dots), \quad (50)^{14}$$

we have from Equations (26), (42), (43), and (50), with $\nu = 1/4$,

$$\left. \begin{aligned} g_n^{(k)} s_{n-1} &= \frac{n(4n-3)(16n^2-1)(2n\xi_k + \zeta_k) P_{2n}(0)}{(16n^2+4n+3)(2n+2k+2)(4n-2k-3)(2n+2k+4)r^{2n+3}} \\ \xi_k &= (2k+3)\beta_{2k+1} - (2k+2)\alpha_{2k+2} \\ \zeta_k &= (2k+3)(2k+2)\beta_{2k+1} - 2(2k^2+8k+7)\alpha_{2k+2} \\ &(n = 1, 2, 3, \dots), \quad (k = 0, 1, 2, \dots). \end{aligned} \right\} (51)$$

for the general term in Equations (46). We now choose $h_n^{(k)}$ in Equation (47) in the form,

$$\left. \begin{aligned} h_n^{(k)} &= \frac{(4n^2\xi_k + 2nL_k + M_k) P_{2n}(0)}{(2n+1)(2n+2)r^{2n+3}}, \\ &(n = 1, 2, 3, \dots), \quad (k = 0, 1, 2, \dots), \end{aligned} \right\} (52)$$

where L_k, M_k are independent of n . Equation (52) evidently conforms to the limit condition (47) for arbitrary choice of the sequences L_k, M_k and, as will be seen later, the corresponding $H^{(k)}$ in Equations (48) admits a closed representation. It is apparent from Equation (47) that the best possible convergence, within the present choice of $h_n^{(k)}$, of the

¹⁴See [12], p. 553.

series in Equation (46), is secured by determining L_k, M_k in such a way that the coefficients of the highest power of n in the numerator of

$$\frac{g_n^{(k)} s_{n-1} - h_n^{(k)}}{h_n^{(k)}} \quad (53)$$

vanish. This requirement leads to

$$\left. \begin{aligned} L_k &= \xi_k - (2k + 2) \xi_k \\ M_k &= (16k^2 + 44k + 24) \xi_k - (2k + 2) \xi_k \\ (k &= 0, 1, 2, \dots). \end{aligned} \right\} \quad (54)$$

We now proceed to establish $H^{(k)}$ in closed form. To this end we recall¹⁵ that

$$\sum_{n=1}^{\infty} \mu^{2n} P_{2n}(0) = \frac{1}{\sqrt{1+\mu^2}} - 1, \quad 0 \leq \mu \leq 1. \quad (55)$$

Two successive integrations with respect to μ of Equation (55), and subsequent division by μ^2 , yield

$$\sum_{n=1}^{\infty} \frac{\mu^{2n} P_{2n}(0)}{(2n+1)(2n+2)} = \frac{\sinh^{-1} \mu}{\mu} - \frac{\sqrt{1+\mu^2}}{\mu^2} + \frac{1}{\mu^2} - \frac{1}{2}. \quad (56)$$

Similarly we obtain, by successive differentiation with respect to μ of Equation (56),

¹⁵See [4], p. 15.

$$\left. \begin{aligned} \sum_{n=1}^{\infty} \frac{2n \mu^{2n} P_{2n}(0)}{(2n+1)(2n+2)} &= -\frac{\sinh^{-1} \mu}{\mu} + \frac{2\sqrt{1+\mu^2}}{\mu^2} - \frac{2}{\mu^2}, \\ \sum_{n=1}^{\infty} \frac{(2n)^2 \mu^{2n} P_{2n}(0)}{(2n+1)(2n+2)} &= \frac{\sinh^{-1} \mu}{\mu} - \frac{(4+3\mu^2)}{\mu^2 \sqrt{1+\mu^2}} + \frac{4}{\mu^2}. \end{aligned} \right\} (57)$$

In view of Equations (48), (52), $H^{(k)}$ in the present instance is obtained by replacing μ in Equations (56), (57) with r^{-1} , subsequently dividing these equations by r^3 , and forming the linear combination apparent from Equation (52). This computation results in

$$\left. \begin{aligned} H^{(k)} &= (\xi_k - L_k + M_k) \frac{\sinh^{-1} \left(\frac{1}{r}\right)}{r^2} + \frac{\xi_k}{r^2 \sqrt{r^2 + 1}} \\ &\quad + (4\xi_k - 2L_k + M_k) \left(\frac{1}{r} - \frac{\sqrt{r^2 + 1}}{r^2}\right) - \frac{M_k}{2r^3}, \end{aligned} \right\} (58)$$

($k = 0, 1, 2, \dots$).

To demonstrate the improvement in the convergence of the original series for $q^{(k)}$, Equations (46), in the present instance, we observe that the general term in this series is of the order $(r^{2n+3} n^{3/2})^{-1}$ as $n \rightarrow \infty$, whereas $g_n^{(k)} s_{n-1} - h_n^{(k)}$ in Equations (49) here is of the order $(r^{2n+3} n^{9/2})^{-1}$.

An analogous procedure was used in the determination of σ_r for $r = 1$, $p = 1$, which was computed merely as a check on the satisfaction of the boundary conditions. Within the number of terms considered in the numerical evaluations of the series solution established earlier, this value of σ_r , which should be zero, was found to be -4×10^{-5} for $\nu = \frac{1}{4}$. This indicates satisfaction of the boundary conditions to at least four significant figures. The variation of the maximum stress σ_{θ} along the axis of symmetry is shown in Table 2. These results are com-

pared in Figure 2 with the corresponding stress values given by Maunsell [1] for the plane analog of the present space problem. As usual, the stress concentration in the space problem is found to be less severe in intensity and more localized in character than it is in its two-dimensional counterpart.

Table 2. The Stress σ for $p = 1$, $\nu = 1/4$.

r	σ
1	2.23
1.15	1.63
1.35	1.29
1.55	1.15
2	1.04
3	1.00

It is interesting to note that the maximum value 2.23 of σ at the bottom of the pit is 7 per cent larger than the maximum stress concentration induced by a spherical cavity in an infinite medium under the same loading conditions,¹⁶ and for $\nu = 1/4$. In contrast, the maximum stress concentration at the bottom of a semi-circular notch in a plate under unit tension at infinity is only 2 per cent larger than the corresponding value appropriate to the infinite plate with a circular hole.¹⁷

¹⁶See [13], pp. 359-362.

¹⁷See [1], [2], [3].

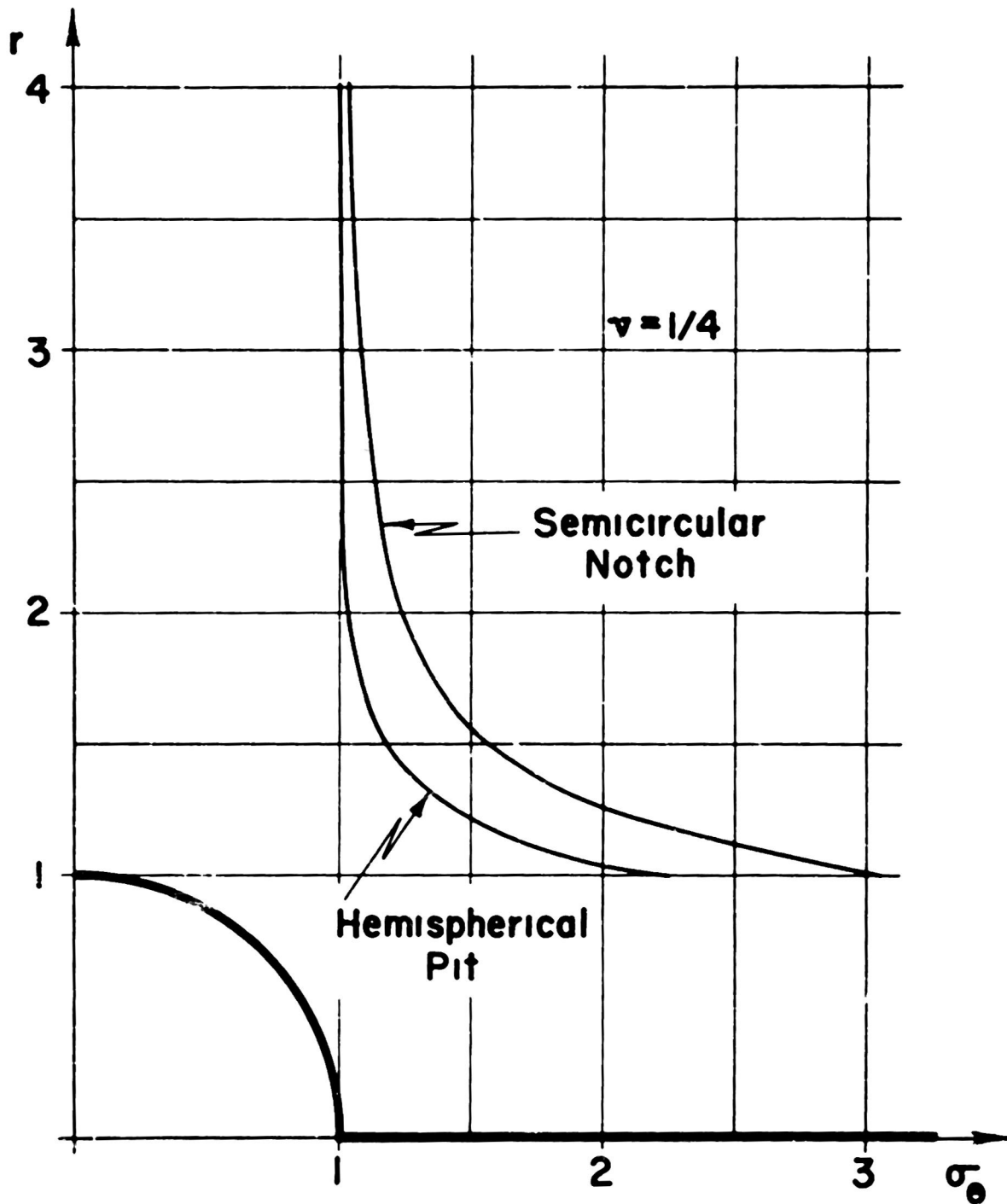

Figure 2

Decay of the Maximum Stress, σ_0 ,
 along the Axis of Symmetry
 $\sigma_x = \sigma_y = 1$ at Infinity

BIBLIOGRAPHY

- [1] "Stresses in a Notched Plate Under Tension," by F. G. Maunsell, London, Edinburgh and Dublin Philosophical Magazine, Series 7, vol. 21, 1936, p. 765.
- [2] "Die Spannungserhöhung durch Kreisbogenkerben," by E. Weinel. Zeitschrift für angewandte Mathematik und Mechanik, vol. 21, 1941, p. 228.
- [3] "On the Stresses in a Notched Plate Under Tension," by Chih-Fing Ling, Journal of Mathematics and Physics, vol. 26, no. 4, 1947, p. 284.
- [4] "The Theory of Spherical and Ellipsoidal Harmonics," by E. W. Hobson, University Press, Cambridge, England, 1931.
- [5] "Tratado de Elasticidad," by E. Butty, Centro Estudiantes de Ingeniería, Buenos Aires, Argentine, 1946.
- [6] "On the Stress-Function Approaches of Boussinesq and Timpe to the Axisymmetric Problem of Elasticity Theory," by E. Sternberg, R. A. Eubanks, and M. A. Sadowsky, Journal of Applied Physics, vol. 22, no. 9, 1951, pp. 1121-1124.
- [7] "Application des Potentiels," by J. Boussinesq, Gauthiers Villars, Paris, France, 1885.
- [8] "On the Axisymmetric Problem of Elasticity Theory for a Region Bounded by Two Concentric Spheres," by E. Sternberg, R. A. Eubanks, and M. A. Sadowsky, presented at the First U. S. National Congress of Applied Mechanics, Chicago, Ill., June, 1951, to appear in the forthcoming Proceedings of the Congress.
- [9] "A Treatise on the Mathematical Theory of Elasticity," by A. E. H. Love, fourth edition, Dover Publications, New York, N. Y., 1944.
- [10] "The Elastic Sphere Under Concentrated Loads," by E. Sternberg and F. Rosenthal, Journal of Applied Mechanics, vol. 19, no. 4, 1952, p. 413.
- [11] "Theory and Application of Infinite Series," by K. Knopp, Hafner Publishing Co., New York, N. Y., 1947.
- [12] "On a Simple Property of the Derivatives of Legendre's Polynomials," by E. Grosswald, Proceedings of the American Mathematical Society, vol. 1, no. 4, 1950, pp. 553, 554.
- [13] "Theory of Elasticity," by S. Timoshenko and J. H. Goodier, McGraw-Hill Book Co., New York, N. Y., 1951.

DISTRIBUTION LIST - PROJECT NR 035-302Administrative, Reference and Liaison Activities

Chief of Naval Research Department of the Navy Washington 25, D. C. Attn: Code 438 (2) : Code 432 (1)	Commanding Officer Office of Naval Research Branch Office 801 Donahue Street San Francisco 24, Calif. (1)
Director, Naval Research Lab. Washington 25, D. C. Attn: Tech. Info. Officer (9) : Technical Library (1) : Mechanics Division (2) : Code 3834 (J. P. Walsh) (1)	Commanding Officer Office of Naval Research Branch Office 1030 Green Street Pasadena, California (1)
Commanding Officer Office of Naval Research Branch Office 495 Summer Street Boston 10, Mass. (1)	Officer in Charge Office of Naval Research Branch Office, London Navy No. 100 FPO, New York, N. Y. (5)
Commanding Officer Office of Naval Research Branch Office 346 Broadway New York 13, N. Y. (1)	Library of Congress Washington 25, D. C. Attn: Navy Research Section (2)
Commanding Officer Office of Naval Research Branch Office 844 N. Rush Street Chicago 11, Illinois (2)	

Department of DefenseOther Interested Government ActivitiesGENERAL

Research & Development Board
 Department of Defense
 Pentagon Building
 Washington 25, D. C.
 Attn: Library (Code 3D-1075) (1)

Armed Forces Special Weapons Project
 P. O. Bcx 2610
 Washington, D. C.
 Attn: Lt. Col. G. F. Blunda (1)

Joint Task Force 3
 12th St. & Const. Ave., N.W. (Temp. U.)
 Washington 25, D. C.
 Attn: Major B. D. Jones (1)

ARMY

Chief of Staff
 Department of the Army
 Research & Development Division
 Washington 25, D. C.
 Attn: Chief of Res. & Dev. (1)

Office of the Chief of Engineers
 Assistant Chief for Works
 Department of the Army
 Bldg. T-7, Gravelly Point
 Washington 25, D. C.
 Attn: Structural Branch
 (R. L. Bloor) (1)

Office of the Chief of Engineers
 Asst. Chief for Military Construction
 Department of the Army
 Bldg. T-7, Gravelly Point
 Washington 25, D. C.
 Attn: Structures Branch
 (H. F. Carey) (1)

Office of the Chief of Engineers
 Asst. Chief for Military Operations
 Department of the Army
 Bldg. T-7, Gravelly Point
 Washington 25, D. C.
 Attn: Structures Development
 Branch (W. F. Woolard) (1)

Engineering Research & Development
 Laboratory
 Fort Belvoir, Virginia
 Attn: Structures Branch (1)

Office of Chief of Ordnance
 Research & Development Service
 Department of the Army
 The Pentagon
 Washington 25, D. C.
 Attn: ORDTB (2)

Commanding Officer
 Watertown Arsenal
 Watertown, Massachusetts
 Attn: Laboratory Division (1)

NAVY

Chief of Bureau of Ships
 Navy Department
 Washington 25, D. C.
 Attn: Director of Research (2)
 : Code 440 (2)
 : Code 421 (1)

Director
 David Taylor Model Basin
 Washington 7, D. C.
 Attn: Structural Mechanics Div. (1)
 : Dr. E. Wenk (1)

Other Interested Government ActivitiesNAVY (Cont.)

Director Naval Engr. Experiment Station Annapolis, Maryland	(1)	Naval Air Experimental Station Naval Air Material Center Naval Base Philadelphia 12, Pennsylvania Attn: Head, Aeronautical Materials Laboratory	(1)
Director Materials Laboratory New York Naval Shipyard Brooklyn 1, New York	(1)	Chief of Bureau of Yards & Docks Navy Department Washington 25, D. C. Attn: Code P-314	(1)
Chief of Bureau of Ordnance Navy Department Washington 25, D. C. Attn: Ad-3, Technical Library	(1)	Officer in Charge Naval Civil Engr. Research and Eval. Laboratory Naval Station Port Hueneme, California	(1)
Superintendent Naval Gun Factory Washington 25, D. C.	(1)	Superintendent U. S. Naval Post Graduate School Annapolis, Maryland Attn: Library	(1)
Naval Ordnance Laboratory White Oak, Maryland RFD 1, Silver Spring, Maryland Attn: Mechanics Division	(2)		
Naval Ordnance Test Station Inyokern, California Attn: Scientific Officer	(1)		
Naval Ordnance Test Station Underwater Ordnance Division Pasadena, California Attn: Structures Division	(1)		
Chief of Bureau of Aeronautics Navy Department Washington 25, D. C. Attn: TD-41, Technical Library : DE-22, C. W. Hurley	(1) (1)		

AIR FORCES

Commanding General
U. S. Air Forces
The Pentagon
Washington 25, D. C.
Attn: Research & Development
Division (1)

Commanding General
Air Materiel Command
Wright-Patterson Air Force Base
Dayton, Ohio
Attn: MCREX-B (E. H. Schwartz) (1)

Office of Air Research
Wright-Patterson Air Force Base
Dayton, Ohio
Attn: Chief, Applied Mechanics
Group (1)

OTHER GOVERNMENT AGENCIES

U. S. Atomic Energy Commission
Division of Research
Washington, D. C. (1)

Argonne National Laboratory
P. O. Bcx 5207
Chicago 80, Illinois (1)

Director
National Bureau of Standards
Washington, D. C.
Attn: Dr. W. H. Ramberg (2)

U. S. Coast Guard
1330 E Street, N.W.
Washington, D. C.
Attn: Chief, Testing & Development
Division (1)

Forest Products Laboratory
Madison, Wisconsin
Attn: L. J. Markwardt (1)

National Advisory Committee for
Aeronautics
1724 F. Street, N.W.
Washington, D. C. (1)

National Advisory Committee for
Aeronautics
Langley Field, Virginia
Attn: Mr. E. Lundquist (1)
; Dr. B. Budiansky (1)

National Advisory Committee for
Aeronautics
Cleveland Municipal Airport
Cleveland, Ohio
Attn: J. H. Collins, Jr. (1)

U. S. Maritime Commission
Technical Bureau
Washington, D. C.
Attn: Mr. V. Russo (1)

Contractors and other Investigators
Actively Engaged in Related Research

Professor Jesse Ormondroyd
University of Michigan
Ann Arbor, Michigan (1)

Dr. N. J. Hoff, Head
Department of Aeronautical
Engineering & Applied Mechanics
Polytechnic Institute of Brooklyn
99 Livingston Street
Brooklyn 2, New York (1)

Dr. N. M. Newmark
Department of Civil Engineering
University of Illinois
Urbana, Illinois (1)

Dr. J. N. Goodier
School of Engineering
Stanford University
Stanford, California (1)

Professor F. K. Teichmann
Department of Aeronautical Engr.
New York University
University Heights, Bronx
New York, New York (1)

Professor C. T. Wang
Department of Aeronautical Engr.
New York University
University Heights, Bronx
New York, New York (1)

Professor E. Sternberg
Illinois Institute of Technology
Technology Center
Chicago 16, Illinois (10)

Professor M. A. Sadowsky
Illinois Institute of Technology
Technology Center
Chicago 16, Illinois (10)

Contractors and other Investigators Actively Engaged in Related Research (Cont.)

Professor B. Fried Washington State College Pullman, Washington	(1)	Dr. Francis H. Clauser Chairman, Dept. of Aeronautics Johns Hopkins University School of Engineering Baltimore 18, Maryland	(1)
Professor E. Reissner Department of Mathematics Massachusetts Institute of Technology Cambridge 39, Massachusetts	(1)	Dr. S. Raynor Armour Research Foundation of Illinois Institute of Technology Chicago 16, Illinois	(1)
Dr. A. Phillips School of Engineering Stanford University Stanford, California	(1)	Professor R. L. Bisplinghoff Massachusetts Institute of Technology Cambridge 39, Massachusetts	(1)
Dr. W. Prager Graduate Division of Applied Math. Brown University Providence 12, Rhode Island	(1)	Dr. R. J. Hansen Massachusetts Institute of Technology Cambridge 39, Massachusetts	(1)
Professor L. S. Jacobsen Stanford University Stanford, California	(1)	Professor A. C. Eringen Illinois Institute of Technology Technology Center Chicago 16, Illinois	(1)
Dr. W. H. Hoppmann Department of Applied Mechanics Johns Hopkins University Baltimore, Maryland	(1)	Professor B. J. Lazan Institute of Technology University of Minnesota Minneapolis 14, Minnesota	(1)
Professor W. K. Krefeld College of Engineering Columbia University New York, New York	(1)	Professor Paul Lieber Dept. of Aeronautical Engineering and Applied Mechanics Polytechnic Institute of Brooklyn 85 Livingston Street Brooklyn 2, New York	(1)
Professor R. M. Hermes University of Santa Clara Santa Clara, California	(1)	Professor George Lee U. S. Naval Post Graduate School Annapolis, Maryland	(1)
Dr. R. P. Petersen Director, Applied Physics Division Sandia Laboratory Albuquerque, New Mexico	(1)		

Contractors and other Investigators Actively Engaged in Related Research (Cont.)

Professor Lloyd Donnell Department of Mechanics Illinois Institute of Technology Technology Center Chicago 16, Illinois	(1)	Library, Engineering Foundation 29 West 39th Street New York, New York	(1)
Dr. J. H. Hollomon General Electric Research Labs. 1 River Road Schenectady, New York	(1)	Professor M. Hetényi Northwestern University The Technological Institute Evanston, Illinois	(1)
Professor T. J. Dolan Dept. of Theoretical and Applied Mechanics University of Illinois Urbana, Illinois	(1)	Professor H. Bleich Dept. of Civil Engineering Columbia University Broadway at 117th Street New York 27, New York	(1)
Professor Lynn Beedle Fritz Engineering Laboratory Lehigh University Bethlehem, Pennsylvania	(1)	Professor Vito Salerno Dept. of Aeronautical Engineering and Applied Mechanics Polytechnic Institute of Brooklyn 85 Livingston Street Brooklyn 2, New York	(1)
Dr. C. B. Smith College of Arts and Sciences Department of Mathematics Walker Hall University of Florida Gainesville, Florida	(1)		