

UNCLASSIFIED

AD _____

DEFENSE DOCUMENTATION CENTER

FOR

SCIENTIFIC AND TECHNICAL INFORMATION

CAMERON STATION ALEXANDRIA, VIRGINIA

DOWNGRADED AT 3 YEAR INTERVALS:
DECLASSIFIED AFTER 12 YEARS
DCD DIR 5200.10



UNCLASSIFIED

THIS REPORT HAS BEEN DECLASSIFIED
AND CLEARED FOR PUBLIC RELEASE.

DISTRIBUTION A
APPROVED FOR PUBLIC RELEASE;
DISTRIBUTION UNLIMITED.

AD No. **7030**

ASTIA



THE PENNSYLVANIA STATE COLLEGE

School of Chemistry and Physics

STATE COLLEGE PENNSYLVANIA

TECHNICAL REPORT ON CONTRACT

Nó -ONR - 269, T. O. III

by

J. G. Aston
Director, Cryogenic Laboratory

April 13, 1953

TABLE OF CONTENTS

<u>Title</u>	<u>Page</u>
Introduction	1
Synthesis and Properties of Trimethylhydrazine	2
Trimethylhydrazine and Tetramethylhydrazine	3 - 11
Infrared and Raman Spectra of Methylhydrazine and Symmetrical Dimethylhydrazine	12 - 21
The Heats of Combustion of the Methyl Substituted Hydrazines and Some Observations on the Burning of Volatile Liquids	22 - 27
The Entropy and Configuration of Methylhydrazine	28 - 30
The Heat Capacity, Heats of Fusion and Vaporization, Vapor Pressures, Entropy and Thermodynamic Functions of Methylhydrazine	31 - 41
The Heat Capacity, Heats of Fusion and Vaporization, Vapor Pressures and Entropy of Symmetrical Dimethylhydrazine	42 - 50
The Thermodynamic Properties and Configuration of Unsymmetrical Dimethylhydrazine	51 - 64

Technical Report N6-omr-269, Task Order III

THE METHYLHYDRAZINES

Introduction

The following technical report records the preparation of trimethyl- and tetramethylhydrazine for the first time and the development of satisfactory synthetic methods for the preparation of large quantities of the ion.

The spectra of methylhydrazine and *sym*-dimethylhydrazine have been determined. The heats of combustion of and third law entropies of methylhydrazine and the two dimethylhydrazines have been measured and conclusion drawn about their configuration.

With the exception of the data on the entropies of *unsym*-dimethylhydrazine all the work has been, or is in course of publication. The latter waits more reliable determination of the vapor pressure.

During the coming year, it is hoped to complete the work on the spectra, third law entropies and configuration of trimethyl- and tetramethylhydrazine and possibly their heats of combustion.

[Copied from the Journal of the American Chemical Society,
73, 2359 (1951)]

"Synthesis and Properties of Trimethylhydrazine"

By J. B. Class and J. G. Aston

We have recently performed the first successful synthesis of trimethylhydrazine, the simplest member of the trisubstituted hydrazine series.

Previous attempts by Klages and co-workers¹ indicated the impracticability

1. F. Klages, G. Nober, F. Kircher and M. Bock, Ann., 547, 1 (1941)

of chloramine coupling and methylation ~~which~~, so we attempted and succeeded in reducing N,N-dimethyl-N'-methylenehydrazine with LiAlH_4 .

Identification of the product resulted from equivalent weight determinations by electrometric titration with HCl (equivalent weight: calcd., 74.13; found, 74.53, 74.59). A cryoscopic determination in water gave a molecular weight of 67.2 (calcd. 74.13) indicating one equivalent per molecule. A satisfactory combustion has not yet been obtained due to the compound exploding in the combustion tube.

Trimethylhydrazine is a colorless liquid possessing a strong, fish-like odor. Unlike hydrazine and the other known methylhydrazines, it is relatively stable to the atmosphere. The compound fumes on dilution with water, the process of solution being strongly exothermic. The low boiling point of 59° , which is lower than that of the methyl and dimethylhydrazines, indicates that the hydrogen bonding characteristic of hydrazine is further decreased by introducing a third methyl group.

A preliminary determination of its physical constants gave the following: b.p. 59° (740 mm.); d_4^{18} 0.814; n_D^{18} 1.406; MR calcd. 23.60, found 22.39; pK_b 7.0 (determined by electrometric titration using a glass electrode.)

Contribution from the School of Chemistry and Physics of
The Pennsylvania State College
TRIMETHYLHYDRAZINE AND TETRAMETHYLHYDRAZINE ¹

1. This research is part of a program of the Chemistry Branch of the Office of Naval Research (Contract N6-onr-269, Task Order 111).
-

J. B. Class ^{2,3}, J. G. Aston, and T. S. Oakwood

2. Allied Chemical and Dye Corporation Fellow, 1951-1952.
3. Present Address - Hercules Experiment Station, Hercules Powder Company, Wilmington, Delaware.
-

Trimethylhydrazine and tetramethylhydrazine have been synthesized. Their boiling points, melting points, refractive indices, densities, and basic dissociation constants have been measured. A comparison of the boiling points of the methylhydrazines, methylamines, and hydrocarbons of similar structure has been made. There is a similar trend for the two series, relative to the hydrocarbons, attributable to the decrease of hydrogen bonding on introducing methyl groups into hydrazine and ammonia respectively. The decomposition of N-trimethylamine-N'-methylimide is discussed.

- - - - -

The methyl-substituted hydrazines are being studied in this laboratory. To complete the series, two new compounds, trimethylhydrazine and tetramethylhydrazine, unknown in spite of previous efforts to prepare them, had to be synthesized. F. Klages and co-workers, who reported the synthesis of the first tri- and tetraalkylhydrazines, sought to prepare these compounds by various routes ⁴. The attempted coupling of two dimethylchloramine molecules using

4. Klages, Nober, Kircher, and Bock, Ann, 547, 1 (1941)
-

copper-bronze and the reaction between dimethylchloramine and dimethylamide

magnesium halide both resulted in disproportionation of the molecules to amines. The reaction between aqueous formaldehyde and hydrazine hydrochloride yielded only polymerization products. Only hydrazoneium salts resulted from methylation attempts with methyl p-toluenesulfonate, trimethyl phosphate, and trimethyl phosphite. Although successful with higher homologues, the alkylation of hydrazine at elevated temperatures failed with methyl chloride. Klages did succeed in condensing formaldehyde and N,N-dimethylhydrazine to methylenedimethylhydrazine. Attempted catalytic reduction of this compound failed due to resinification on the catalyst.

The methods used in this investigation, with success, followed the equation given below.

Trimethylhydrazine ⁵

5. Class and Aston, THIS JOURNAL, 73, 2359 (1951) have given a preliminary report of the synthesis of trimethylhydrazine.

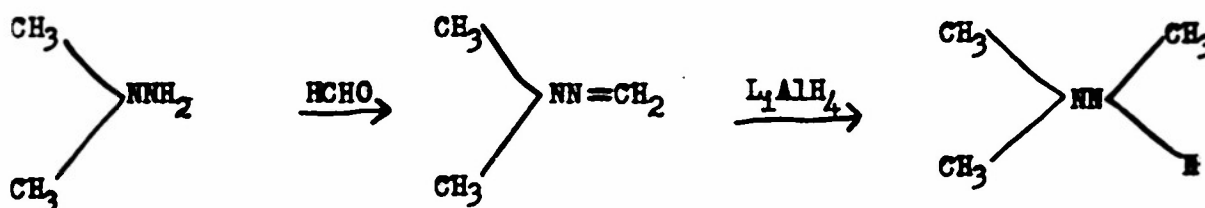

Tetramethylhydrazine

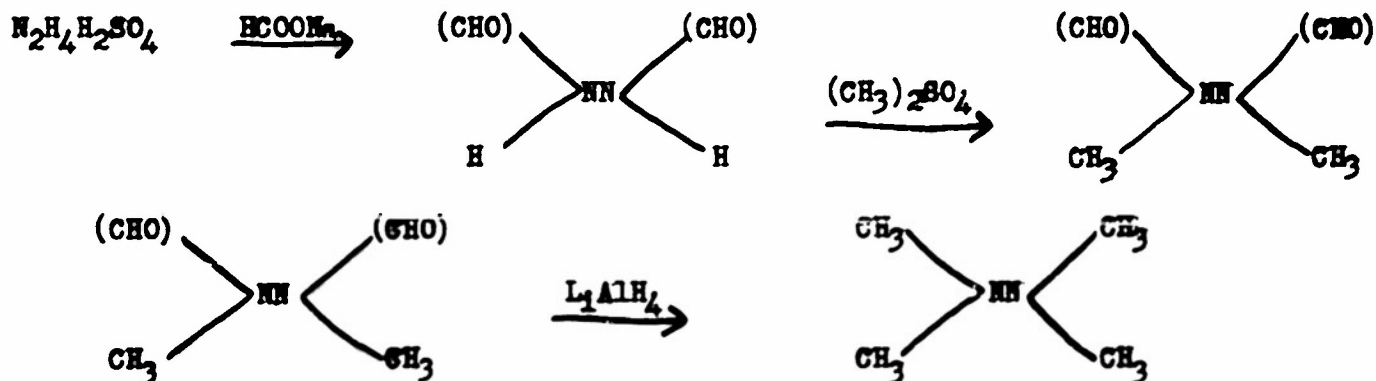

The reductions with lithium aluminum hydride proceeded smoothly. Even though an excess of reducing agent was used, no cleavage of the N-N bond to produce amine was observed. If the reductions are successful with other

hydrazones and hydrazides, the methods may become useful preparations for the other alkylhydrazines.

The compounds prepared are clear, colorless, volatile liquids possessing an offensive odor. They are hygroscopic, reduce hot Fehlings solution only slightly, and are stable relative to the other methylhydrazines.

The physical properties of trimethylhydrazine and tetramethylhydrazine are listed in Table I. Methylene dimethylhydrazine has been included because of its similarity to the other methylhydrazines.

Assuming that the difference between the boiling point of an organic nitrogen compound and the structurally analogous hydrocarbon is caused by hydrogen bonding, a simple subtraction should give a measure of this effect. This is done for hydrazine and the methylhydrazines in Table II and for ammonia and the methylamines in Table III. The similarities of the ΔT values in the tables are immediately seen. This shows that the effect of hydrogen bonding in the two series is about the same.

Table I
Physical Properties

	TRIMETHYLHYDRAZINE	TETRAMETHYLHYDRAZINE	METHYLENEDIMETHYL- HYDRAZINE
b.p.	60° (735 mm.)	73° (730 mm.)	72° (730 mm.)
m.p.	-73 ^a	-118° ± 10°	-103° ± 10°
n_D^{20}	1.4039	1.4040	1.4338
d_4^{20}	0.7716	0.7794	0.8125
K_b	6 x 10 ⁻⁸	2 x 10 ⁻⁸	—
E	7.1 ± 0.5 (29°)	—	9.1 ± 0.5 (28°)

a. This value is from the heat capacity measurements of J. L. Wood, which will be published shortly.

Table II

BOILING POINT COMPARISON OF
HYDRAZINES WITH ANALOGOUS SATURATED HYDROCARBONS

Structure	X = CH	Ref.	X = H	Ref.	ΔT
$H_2X - XH_2$	-89	(6a)	113	(8)	201
$\begin{array}{c} Me \\ \\ H > X - XH_2 \end{array}$	-42	(6b)	87	(8)	129
$\begin{array}{c} Me \\ \\ H > X - X < \begin{array}{c} Me \\ \\ H \end{array} \end{array}$	-1	(6c)	81	(9)	82
$Me_2 X - XH_2$	-12	(6d)	63	(9)	75
$Me_2 X - \begin{array}{c} Me \\ \\ H \end{array}$	28	(7)	60		32
$Me_2 X - X Me_2$	58	(7)	73		15

(Me - methyl)

Table III

BOILING POINT COMPARISON OF
AMINES WITH ANALOGOUS SATURATED HYDROCARBONS

Structure	X = CH	Ref.	X = N	Ref.	ΔT
XH_3	-162	(7)	-33	(8)	129
$MeXH_2$	-88	(7)	-6	(8)	82
Me_2XH	-42	(7)	7	(8)	49
Me_3X	-12	(7)	3	(8)	15

(Me - methyl)

- (6a) Witt and Kemp, THIS JOURNAL, 59, 272 (1937)
- (6b) Kemp and Egan, ibid., 60, 1521 (1938)
- (6c) Aston and Messerly, ibid., 62, 1917 (1940)
- (6d) Aston, Kennedy and Schumann, ibid., 62, 2059 (1940)
- (7) Egleff, Physical Constants of Hydrocarbons I, Reinhold Publishing Corp., New York, 1939
- (8) International Critical Tables I, McGraw-Hill Co., New York, 1926
- (9) Heilbron, Dictionary of Organic Compounds I, Oxford University Press, New York, 1946, p.926

The reaction between methyl iodide and the lithium-aluminum complex of trimethylhydrazine was investigated as a method of preparation of tetramethylhydrazine. Contrary to expectations, the nitrogen-nitrogen bond was cleaved producing the methylamines and ammonia in the following yields: ammonia, 16%; methylamine (assumed), 1%; dimethylamine, 14%; and trimethylamine, 22%. All except methylamine were identified in the mixture by preparation of derivatives. The yields were determined by titration of the chloroform soluble and insoluble hydrochlorides, and are only approximate.

Klages reported similar results for his reaction of methyl bromide with *N,N*-dimethyl-*N'*-ethylhydrazido magnesium chloride ⁴. The results of both reactions can be explained if an intermediate analogous to an amine oxide is assumed.

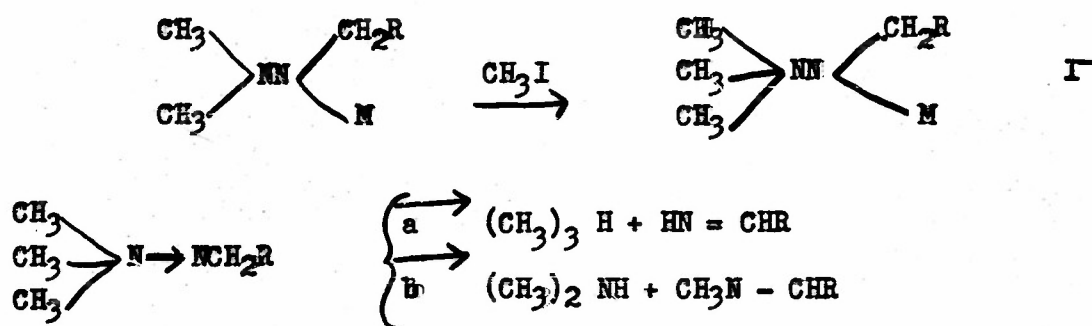

R is H or CH₃. m is an equivalent of metal ion.

The Schiff base structures can be either hydrolysed or polymerized. The decompositions by paths a and b are analogous to those of trialkylamine oxides ¹⁰.

10. T. Taylor and W. Baker, Sigwick's Organic Chemistry of Nitrogen, Oxford, 1945, p.167

Path a corresponds to yielding atomic oxygen, the nitrogen free radical having undergone an obvious rearrangement. Path b corresponds to the decomposition yielding a secondary amine and an aldehyde.

Experimental

N,N-Dimethylhydrazine - The N,N-dimethylhydrazine was prepared by the reduction of nitrosodimethylamine with zinc dust and acetic acid, as described by Hatt ¹¹.

11. Hatt, Org. Syn. Col. II, J. Wiley and Sons, Inc., New York, 1943, p.211

The product was collected as an aqueous solution of about 75% concentration.

Methylenedimethylhydrazine - In a 500 ml. round bottom flask equipped with an addition funnel and stirrer was placed 132 ml. (1.4 moles) of N,N-dimethylhydrazine solution. While stirring, 128 g. (1.6 moles) of 37% formaldehyde solution was added keeping the temperature at 25-30°. The reaction mixture was then saturated with sodium hydroxide, the solution still being stirred. The upper layer of product was separated, and dried and distilled from sodium hydroxide three times. It was finally dried and fractionated from calcium hydride. Product was collected from 70-72°. Yield - 78-83 g. (78-83%).

Analysis: Calcd: C - 49.96%; H - 11.18%; MR - 22.97. Found: C - 50.28%; H - 10.98%; MR - 23.14.

Trimethylhydrazine - A 1 l. round bottom, three necked flask was equipped with a stirrer, addition funnel, and reflux condenser. To 300 ml of an ether solution of lithium aluminum hydride (12.6 g., 0.33 moles LiAlH_4) in the flask, 98.5 ml. (80 g., 1.11 moles) of methylenedimethylhydrazine was added at a rate just fast enough to reflux the ether. Addition took 3 hrs. The reaction mixture was stirred and refluxed for 1 hr. longer. Water was then added carefully and the mixture was poured into about 200 g. ice. After addition of 500 ml. of 6N hydrochloric acid, the resulting solution was concentrated on a steam bath to about 200 ml.

A 1 l. round bottom, two necked flask was fitted with an addition funnel and a condenser set for distillation. The hydrochloride solution was carefully

added to a hot solution of 280 g. sodium hydroxide in 120 ml. water in the flask. The distillate, which was collected until the temperature reached 100°, was saturated with sodium hydroxide, the temperature being kept below 30° by cooling and stirring. The product was separated, dried and distilled from sodium hydroxide twice. The final drying was over calcium hydride, from which it was fractionated. Product was collected from 58.8-60.1°. Yield - 57-61 g. (69-74%). Analysis: Calcd: C - 48.61%; H - 13.60%; N - 37.79%; Mol. wt. - 74.13; MR - 23.14. Found: C - 48.75%; H - 13.33%; N - 37.35%; Mol. wt. - 74.2 (potentiometric titration), 68.4 (cryoscopic in water), 75.0 (vapor density); MR - 23.49.

N,N'-Diformylhydrazine - The procedure used was described by Pellissari ¹². A

12. Pellissari, Gazz. chim. Ital., 39, I 529 (1909)

continuous extraction of the product was introduced in place of the hand extraction.

N,N'-Diformyl-N,N'-dimethylhydrazine - The method used was essentially that described by Thiele ¹³. In an attempt to improve the yield, an excess of di-

13. J. Thiele, Ber., 42, 2576 (1909)

methyl sulfate was used; and ether was replaced by chloroform in the extraction. Results were erratic and yields varied from 30-78% theoretical.

Tetramethylhydrazine - A 1 l. round bottom^d three necked flask was fitted with a stirrer, addition funnel, and reflux condenser. In the flask was placed 23.0 g. (0.60 moles) of lithium aluminum hydride. About 500 ml. of ether dried over calcium hydride was distilled in, and stirring was started to hasten solution.

After addition was effected, 58 g. (0.50 moles) of N,N'-diformyl-N,N'-dimethylhydrazine was added at a rate rapid enough to reflux the ether. The hydrazine in the addition funnel was kept fluid by using an infrared lamp. Stirring and refluxing was continued for 1 hr. after addition was completed.

After 150 ml. water was added carefully, the ether was stripped off through a fractionating column. Then 80 g. of sodium hydroxide in 100 ml. water was added and the mixture distilled until the temperature reached 100° . The distillate was saturated with sodium hydroxide while being stirred with the temperature kept below 30° . The product was separated, dried, and distilled from sodium hydroxide. The final drying was over calcium hydride, from which it was fractionated. Product was collected from $72.0 - 73.1^{\circ}$. A yield of approximately 15% was obtained as an average of several preparations, none of which ~~was~~^{was} free from mechanical difficulties ^vpreventing complete isolation. Analysis: Calcd: C - 54.50%; H - 13.72%; N - 31.78%; Mol. wt. 88.15; MR - 27.81. Found: C - 54.20%; H - 13.61%; N - 31.14%; Mol. wt. - 90.4 (potentiometric titration), 84.0 (cryoscopic in water), 87.6 (vapor density), MR - 27.66.

Reaction of Methyl Iodide with the Lithium-Aluminum Complex of Trimethylhydrazine -

In the same manner as described in the preparation of trimethylhydrazine, 44.5 ml. (36 g., 0.5 moles) of methylenedimethylhydrazine was added to 143 ml. (6.0 g., 0.16 m) of an ether solution of lithium aluminum hydride. Addition of 34 ml. (77.5 g., 0.55 moles) of methyl iodide followed at a rate which just refluxed the ether. After 2 1/2 hrs. stirring and refluxing, water was carefully added. The mixture was poured onto about 150 g. of ice and then 250 ml. of ~~the~~ hydrochloric acid was added. The solution was concentrated by evaporation on a steam bath.

A 1 l. round bottom, ^{ed}two necked flask was fitted with an addition funnel and a condenser set for distillation. A trap containing hydrochloric acid was connected to the receiver. The solution of hydrochlorides was added to a hot solution of 140 g. of sodium hydroxide in 60 ml. of water in this flask. Liquid was distilled until the temperature reached 100° . The distillate was saturated with sodium hydroxide and the evolving gases passed through the hydrochloric acid trap. No hydrazine layer separated. The solution was further degassed by 1/4 hr. boiling after completion of the saturation. The dried hydrochlorides

from the trap weighed 41 g.

Ammonia was identified as ammonium chloride, diethylamine as the benzenesulfonamide, and trimethylamine as the picrate. Solubility separations with n-butyl alcohol chloroform indicated that the presence of methylamine could be in no more than trace quantities.

The quantitative distribution of the amines reported above was calculated from the titration of the chloroform soluble and insoluble hydrochlorides with standard silver nitrate.

The values of the basic dissociation constants reported in Table I were obtained from the hydrogen ion concentrations obtained during the potentiometric titrations to determine the equivalent weights. The dielectric constants were obtained by a beat frequency method in an apparatus loaned by Prof. W. C. Fernelius.

State College, Pennsylvania
February 21, 1953

[Copied from The Journal of Chemical Physics, Vol. 19, No. 6, 704-707, June, 1951]

"Infrared and Raman Spectra of Methylhydrazine and Symmetrical Dimethylhydrazine"

D. W. E. Axford, G. J. Janz and K. E. Russell

Raman spectra for liquid methylhydrazine and sym-dimethylhydrazine, and infrared spectra for both liquid and vapor methylhydrazine and sym-dimethylhydrazine in the region $1600-650\text{ cm}^{-1}$ have been obtained. Frequency assignments are proposed for methylhydrazine and sym-dimethylhydrazine. The strong polarization of the Rayleigh scattering from these two compounds is explained on the basis of associated structures of approximately spherical symmetry.

Recently, a series of measurements has been carried out in the Cryogenic Laboratory of this college on the thermodynamic properties of methylhydrazine and symmetrical dimethylhydrazine ¹. In order to compare the entropies determined experimentally with those

1. Aston, Janz and Russell (to be published)

calculated from molecular and spectroscopic data, assignments of the fundamental vibrational frequencies of these two molecules are required. For this purpose Raman data on methylhydrazine are already available from the work of Kahovec and Kohlrausch ², and on sym-

2. L. Kahovec and K. W. F. Kohlrausch, Z. physik. Chem. B38, 96 (1937)

dimethylhydrazine from that of Kahovec and Kohlrausch ² and West and Killingsworth ³.

3. W. West and R. B. Killingsworth, J. Chem. Phys., 6, 1 (1938)

Considerable divergences appear in the results on sym-dimethylhydrazine, however, and the Raman spectra of both compounds have been reinvestigated with samples of known purity. As there are no published infrared data on methylhydrazine and sym-dimethylhydrazine, infrared spectra have been obtained in the rock salt region in both the liquid and vapor phases. Assignments for methylhydrazine and sym-dimethylhydrazine based on these data are presented here, together with some comments on hydrogen bonding in the liquid phase.

EXPERIMENTAL

The samples of methylhydrazine and sym-dimethylhydrazine were identical with those used in the calorimetric studies. They were prepared according to the methods of Organic Syntheses ⁴ and were purified by distillation and fractional melting ⁵.

4. Organic Syntheses (John Wiley and Sons, Inc., New York, 1943) collective Vol. II, pp. 208, 395.

5. J. G. Aston and S. V. Mastrangelo, *Analytical Chem.*, 22, 636 (1950)

The solid insoluble impurity was found to be 0.25 mole percent for methylhydrazine and 0.38 mole percent for sym-dimethylhydrazine.

The Raman spectrograph used in these investigations has already been described ^{6,7}.

6. Rank, Scott, and Fenske, *Ind. Eng. Chem. Anal. Ed.* 14, 816 (1942)

7. Rank, Sheppard, and Szasz, *J. Chem. Phys.*, 16, 698 (1948)

The Raman spectra are listed in Tables I and II and agree in the main with those obtained by Kahovec and Kehlrausch. It was impossible to find any frequencies below 350 cm^{-1} , despite the extremely intense exposures obtained with low pressure mercury arcs and a praseodymium nitrate filter. The Raman lines were very broad in many cases, and it was often difficult to decide the exact positions of the line centers.

Infrared spectra of methylhydrazine and sym-dimethylhydrazine were obtained for both the liquid and vapor phases. Experimental difficulties in handling the extremely reactive methylhydrazine in the liquid phase made it impossible to obtain accurate percentage transmission curves for this substance, but it was possible to obtain reasonably accurate values for the positions of the main bands along with the general features of the spectra. All traces were taken on a Perkin-Elmer spectrometer (Model 12c), with a rock-salt prism, used in conjunction with a Brown recorder. The results of these infrared investigations are listed in Tables I and II for the region $1600\text{--}650\text{ cm}^{-1}$. The bands near 3000 cm^{-1} also were obtained, but the low resolution at these wavelengths makes a comparison with the Raman spectra of doubtful value.

DISCUSSION

If methylhydrazine and sym-dimethylhydrazine possess a skew configuration similar to that of the parent molecule hydrazine ⁸, neither of these molecules belongs to a symmetry class higher than C_2 and all fundamental modes are infrared and Raman active. A comparison of the infrared and Raman spectra of liquid sym-dimethylhydrazine shows a number of coincidences confirming the absence of a center of symmetry.

Table I
Infrared and Raman spectra of methylhydrazine
(all measurements at 30°C, approx).^{a, b}

Data of Kahovec and Kohlrausch	Raman	Infrared	
	Present work	Liquid phase cell thickness = 0.026 mm	Vapor phase path length = 10 cm, vap. press. = 46 mm
281 (1)			
322 (1)			
445 (2)	443 (M) sp	814 (S)	770 (S)
819 (4)	816 (Mb) pp	951 (S)	886 (S)
			934 (W)
975 (1)	982 (Wb) sp	984 (M)	969 (M)
1010 (1)			
		1042 (M)	
	1098 (W) dp	1099 (S)	1103 (W)
1092 (3b)	1117 (W) dp	1118 (M)	1122 (W)
	1137 (W) dp		
1188 (2)			
1209 (2)	1197 (W) sp	1207 (M)	1197 (V.W.)
			1220 (V.W.)
			1278 (V.W.)
		1308 (M)	1296 (W)
1415 (1?)	1412 (M) dp		
1450 (4b)	1441 (Sb) dp	1443 (S)	
		1474 (S)	
		1615 (M)	1464 (M)
1615 (1b)	1587 (Wb) dp		
1741 (00?)			
2778 (10)	*2778 (S)		
2865 (4vb)	*2865 (Mb) sp		
2933 (12b)	*2933 (Sb) sp		
2965 (8)	*2965 (Mb) dp		
3177 (8)	*3177 (W) sp		
3245 (8vb)	*3245 (Wb) sp		
3317 (6b)	*3317 (Wb) sp		

* Bands marked with an asterisk were observed on our plates but were not measured, and Kahovec and Kohlrausch's values have been used.

^a Intensities in our measurements are given as V.W., W, M, S, representing very weak, weak, medium, strong, respectively.

^b Polarizations are given as dp, depolarized; pp, partially polarized; sp, strongly polarized.

Table II

Infrared and Raman spectra of sym-dimethylhydrazine

(all measurements at 30°C, approx).^{a, b}

Data of West and Killingsworth	Raman	Data of Kahovec and Kohlrausch	Present work	Liquid phase cell thickness = 0.026 mm	Infrared Vapor phase path length = 10 cm vap. press. = 46 mm
		156 (3b)			
		270 (1/2)			
473 (2) dp		430 (1/2)	422 (S) sp		
		476 (2)	483 (VS) pp		
		530 (1/2)		753 (S)	720 (S)
		810 (2b)	790 (Mb) dp	801 (W)	
		925 (1b)	923 (M) sp	918 (S)	865 (S)
1010 (2)		1010 (1b)	1019 (S) dp	1022 (W)	910 (W)
		1025 (1b)		1042 (S)	1045 (W)
					1055 (W)
					1086 (W)
		1096 (3b)	1091 (S) sp	1098 (S)	1099 (W)
1118 (2)		1123 (1b)	1110 (M) dp?	1112 (M)	1114 (W)
1201 (2)		1203 (2b)	1132 (M) dp?	1137 (W)	
1301 (2)			1203 (S) sp	1208 (S)	1197 (W)
		1405 (2b)	1405 (VS) dp		
		1446 (4b)	1442 (VS) dp	1453 (S)	1456 (M)
1465 (5)		1473 (3b)	1476 (VS) dp	1477 (S)	1476 (M)
		1605 (0)			
2790 (6) sp		2776 (8b)	2790 (VS) sp		
			2824 (VS) pp		
2838 (4) dp		2840 (6b)	2843 (VS) pp		
2867 (4) dp		2875 (7b)	2916 (VS) dp		
2940 (10) sp		2940 (12b)	2946 (VS) dp		
2973 (9) dp		2973 (2b)			
3099 (3)		(3170) (4b)			
3226 (10) sp		3219 (5b)	3223 (S) sp		
3319 (6) dp		3319 (3b)	3294 (W) pp		

^a Intensities in our measurements are given as W, M, S, VS, representing weak, medium, strong, very strong, respectively.

^b Polarizations are given as dp, depolarized; pp, partially polarized; sp, strongly polarized.

8. W. G. Penney and G. B. B. M. Sutherland, *Trans. Faraday Soc.*, **30**, 898 (1934)

Before attempting detailed assignments, the general principles used to distinguish between the skeletal stretching and CH and NH deformation modes that occur between 1300 and 700 cm^{-1} will be discussed. It appears to be a general rule^{9,10} that a low

9. K. W. F. Kohlrausch, Ramanspektren (Becker and Eiler, Leipzig, 1943), p.221, Fig. 84.

10. N. Sheppard and G. J. Szasz, *J. Chem. Phys.*, **17**, 86 (1949)

skeletal stretching mode of a chain of C, N and O atoms occurs in the Raman effect as a strong line between 800 and 950 cm^{-1} , whereas the higher unsymmetrical modes are usually of fair strength in both the Raman and infrared spectra. When polar linkages are involved, e.g., C - O, or C - N as in the present case, one of the high frequency modes is often very strong in the infrared, presumably because the vibration involving the polar linkage gives rise to a large change in dipole moment. All straight chain alcohols, for example, show a strong absorption between 1050 and 1085 cm^{-1} which is usually referred to as a C - O stretching mode^{11,12}.

11. J. Leccmter, Traite-de Chimie Organique (Grignard and Baud, Masson, Paris, 1936) Vol. 2, pp. 143-293.

12. See the spectra of straight chain alcohols in Barnes, Gore, Liddell and Williams, Infra-Red Spectroscopy (Reinhold Publishing Corporation, New York, 1944).

There is considerable evidence for hydrogen bonding in liquid methylhydrazine and sym-dimethylhydrazine, so that marked shifts in frequencies involving the N-H linkages might be expected on passing from the vapor to the liquid state. It is well established that when involved in hydrogen bonding the X -H stretching mode is always lower in frequency in the liquid state as compared to the vapor.

Furthermore, in the case of water and hydrogen peroxide, and probably of methyl alcohol, the OH deformation frequency increased on passing from vapor to liquid^{13,14}.

13. M. M. Davies, *Ann. Repts. Prog. Chem. (London)* **43**, 5 (1946)

14. P. A. Giguere, *J. Chem. Phys.*, **18**, 86 (1950)

In the infrared spectra of both methylhydrazine and sym-dimethylhydrazine, there occur two extremely strong absorptions in the vapor state between 700 and 900 cm^{-1} which are considerably increased in frequency (by 40-70 cm^{-1}) in the liquid phase. These have accordingly, been assigned to deformation modes involving the NH and NH_2 groups.

In assigning the methyl wagging and the skeletal modes, reference has been made to the assignment for n-butane ¹⁵. The NH_2 deformation modes have been picked out by comparison

15. Szasz, Sheppard, and Rank, J. Chem. Phys., 16, 704 (1948)

with the spectra of hydrazine ¹⁶ and methylamine ¹⁷. The assignment of CH and NH

16. Scott, Oliver, Cross, Hubbard and Huffman, J. Am. Chem. Soc., 71, 2293 (1949)

17. A. P. Cleaves and E. K. Plyler, J. Chem. Phys., 7, 563 (1939)

stretching CH_3 deformation modes is a well-established procedure, and there is little doubt about the skeletal bending modes.

The assignments given in Table III for the controversial region 700-1350 cm^{-1} are discussed briefly below. It should be emphasized that as far as the methyl wagging modes and a few of the NH deformation modes are concerned, the assignment is to some extent schematic and may have to be changed in detail at a later date.

In methylhydrazine the strongest Raman line in the region 800-1000 cm^{-1} lies at 816 cm^{-1} , and accordingly, this has been selected as the lowest skeletal stretching mode. Similarly, the strongest infrared band in the region 1050-1150 cm^{-1} , vis., at 1099 cm^{-1} (1103 cm^{-1} in the vapor), has been chosen for the higher skeletal stretching mode. In accordance with the earlier discussion, the strong vapor phase infrared absorptions at 770 cm^{-1} and 886 cm^{-1} (814 cm^{-1} and 951 cm^{-1} in the liquid) are allocated to NH and NH_2 deformation modes. In methylamine the NH_2 wagging mode occurs at 783 cm^{-1} ¹⁷, while in hydrazine there are two such modes near 830 and 950 cm^{-1} ¹⁶, 886 cm^{-1} has been chosen as the corresponding mode in methylhydrazine. Since strong absorptions occur in sym-dimethylhydrazine between 700 and 900 cm^{-1} , it is safe to choose 770 cm^{-1} as a deformation mode involving the lone NH grouping. By analogy with methylamine ¹⁷, the symmetrical

NH_2 deformation is certainly at 1587 cm^{-1} in the liquid. The band at 1197 cm^{-1} is assigned as a CH_3 wagging mode, since it also is observed in the infrared spectrum of unsymmetrical dimethylhydrazine and cannot therefore be allotted to an N - H deformation vibration. There remain four frequencies, 1137 , 1296 , 969 , and 1122 cm^{-1} which might reasonably be considered as fundamentals. Of these, the frequency at 1137 cm^{-1} has been chosen as the NH_2 rocking mode by analogy with the spectrum of hydrazine and methylamine^{16,17}. The frequency at 969 cm^{-1} has been assigned as the other methyl wagging mode (see reference 15), and the one at 1122 cm^{-1} as the remaining NH deformation vibration. No reasonable assignment is available for the band 1296 cm^{-1} , and it is assumed to be a combination or difference frequency.

No attempt has been made to assign the torsion modes. Kohlrausch reports two frequencies in the region below 350 cm^{-1} , but, as stated earlier, these results were not duplicated in the present investigation.

In sym-dimethylhydrazine, similar arguments lead to the selection of 801 and 1099 cm^{-1} as two of the skeletal stretching modes. The third might be expected to lie between 900 and 1050 cm^{-1} by analogy with n-butane¹⁵, and 1019 cm^{-1} , a line which is weak in the infrared and strong and depolarized in the Raman, has been chosen for this mode. The strongly shifted bands at 720 cm^{-1} and 865 cm^{-1} are attributed to NH deformation modes, as also is 1114 cm^{-1} , while the line at 1132 cm^{-1} is chosen as the remaining NH deformation mode. The bands at 1045 cm^{-1} and 1197 cm^{-1} have been allocated in semischematic fashion to the CH_3 wagging modes, each being assigned a double degeneracy.

ROTATIONAL ISOMERISM IN METHYLHYDRAZINE

Rotational isomerism in methylhydrazine may give rise to a trans form and two skew forms (see Janz and Russell¹⁸). Measurements of the Raman spectrum of this compound

18. G. J. Janz and K. E. Russell, J. Chem. Phys., 17, 1352 (1949)

were made at different temperatures in an effort to discover whether temperature had any significant effect on the relative concentrations of the various forms. The Raman spectrum of liquid methylhydrazine at -48°C showed no detectable changes in the relative

Table III

Assignments for methylhydrazine and sym-dimethylhydrazine

Methylhydrazine		Dimethylhydrazine	
Mode	Frequency (cm ⁻¹)	Mode	Frequency (cm ⁻¹)
Skeletal bending	443	Skeletal bending	422,483
Skeletal stretching	816,1103	Skeletal stretching	801,1019,1099
NH ₂ sym. deformation	1587	N-H deformation	720,865,1132,1114
NH ₂ wagging and rocking	886,1137	CH ₃ wagging	1045(2), 1197(2)
NH deformation	770,1122	CH ₃ deformation	1405,(2),1456(2)
CH ₃ wagging	969,1197		1476 (2)
CH ₃ deformation	1412,1441,1474	C-H stretching	2824,2843,2916(2), 2946 (2)
C-H stretching	2865,2933,2965	N-H stretching	3223,3294
N-H stretching	3177,3245,3317		

intensities of any of the lines as compared with the spectrum at 30°C. Jans and Russell¹⁸ conclude from entropy studies that gaseous methylhydrazine exists primarily as a single skew form, and these Raman results indicate that the same conclusion holds for liquid methylhydrazine at 25°C.

RAYLEIGH SCATTERING AND HYDROGEN BONDING

The comparatively high boiling points of hydrazine, methylhydrazine, and sym-dimethylhydrazine are a good indication of hydrogen bonding in the liquid phase. The boiling points decrease with increasing methyl substitution, suggesting that hydrogen bonding decreases as one proceeds from hydrazine to sym-dimethylhydrazine. The extent of hydrogen bonding in the liquid phase must be considerable even in sym-dimethylhydrazine, however, as is evidenced by the frequency shifts observed in passing from the liquid to the vapor state. The Raman lines of all three substances are unusually broad, and this effect may also be attributed to hydrogen bonding.

To obtain further information, measurements have been made on the polarization of the Rayleigh scattering from methylhydrazine, using essentially the experimental method of Douglas and Rank¹⁹. These results may be used to investigate the symmetry of the scattering

19. A. E. Douglas and D. H. Rank, J. Opt. Soc. Am., 38, 281 (1948)

unit (see Bhagavantam²⁰). It was pointed out to us by Rank that, in the liquid state, linear or planar molecules almost invariably yield depolarized Rayleigh scattering. The heavy atoms seem to determine the effective shape of the scattering particle. Usually when definite association is present the Rayleigh scattering is strongly polarized. A more extreme example of this phenomenon exists in the case of light scattering from colloids and glasses, where it is well known that molecular clustering must approximate to spherical symmetry. Measurements of the polarization of the Rayleigh scattering of methylhydrazine gave values for rho of 0.034 at 30°C and 0.046 at 70°C. These values would suggest an approach to spherical symmetry in the scattering unit which is possible only if associated structures are considered. Linear or planar scattering units would probably yield a rho value between 0.2 and 0.6. The value of the rho for sym-dimethylhydrazine was 0.2 at

20. S. Bhagavantam, Scattering of Light and The Raman Effect (The Registrar, Andhra University, Waltair 1942)

30°C. It is concluded from this evidence that there is considerable hydrogen bonding in liquid methylhydrazine and sym-dimethylhydrazine which gives associated structures of approximately spherical symmetry.

Vapor density experiments indicate that hydrazine ²¹ and methylhydrazine ²² are not

21. P. A. Giguere and V. Schomaker, J. Am. Chem. Soc., 65, 2025 (1943)

22. Dr. S. Isserow (private communication)

appreciably associated in the vapor phase. The above assignments have been made using vapor phase frequencies as far as possible, this being of particular importance for frequencies below about 1000 cm^{-1} in the calculation of the vibrational entropy contribution.

ACKNOWLEDGEMENT

We should like to acknowledge the advice and encouragement we have received from Dr. J. G. Aston and Dr. D. H. Rank, and the helpful discussions with Dr. N. Sheppard and Dr. D. M. Simpson. We are also grateful to Mr. E. R. Shull for considerable assistance in taking the Raman spectra.

[Copied from the Journal of the American Chemical Society, 74, 2484 (1952)]
 Contribution from the Department of Chemistry, Pennsylvania State College

"The Heats of Combustion of the Methyl Substituted Hydrazines and Some Observations
 on the Burning of Volatile Liquids"

By John G. Aston, Elizabeth J. Rock and Saul Isserow

The method of burning volatile reactive liquids in a combustion bomb is discussed. A modified method is outlined in which a small soft-glass cylindrical vial is used as the sample container, and a small pellet of benzoic acid acts as an auxiliary ignitor in the combustion process. Values for the heats of combustion are reported as follows: methylhydrazine, 311.711 kcal./mole; symmetrical dimethylhydrazine, 473.454 kcal./mole; unsymmetrical dimethylhydrazine, 472.648 kcal./mole.

INTRODUCTION

The interest in substituted hydrazines both as jet engine fuels and from a theoretical point of view makes it desirable to have values for the heats of combustion of methyl substituted hydrazines. The heat of combustion of hydrazine has been determined by Hughes, Corruccini and Gilbert ¹.

1. A. M. Hughes, R. J. Corruccini and E. C. Gilbert, THIS JOURNAL, 61, 2639 (1939)

While the third law entropies of methylhydrazine and symmetrical dimethylhydrazine have already been determined in this Laboratory ^{2,3} values of the heats of formation required to

2. J. G. Aston, H. L. Fink, G. J. Janz and K. E. Russell, ibid., 73, 1939 (1951)
 3. J. G. Aston, G. J. Janz and K. E. Russell, ibid., 73, 1943 (1951)

calculate reliable values of the free energy of formation are lacking.

The present paper describes the experimental work involved in the determination of heats of combustion of these two compounds and of un-symmetrical dimethylhydrazine and gives the values so obtained.

During the work, evidence was obtained about the function of thin flat-walled bulbs in burning of liquids. It is shown that such bulbs seldom, if ever, stand the pressure of oxygen in the bomb. Rather, they operate through breaking gently without splashing the liquid out of the crucible. This is discussed in further detail in the experimental section.

EXPERIMENTAL

Apparatus and Method. - The apparatus and method were similar to those used by many previous investigators ^{4,5}. The bath was essentially like that described by Dickinson ⁴

4. H. C. Dickinson, Bulletin Bur. Standards, 11, 189 (1915)
 5. R. S. Jessup and G. B. Green, J. Research Nat. Bur. Standards, 13, 469 (1934)

except that it was made to accommodate twin calorimeter assemblies.

All temperature measurements were made with a flat calorimetric type resistance thermometer (Leeds and Northrup, Catalog No. 8160, Serial No. 326349).

The pressure-tight seal in the electrode assembly of the combustion bomb, described by Dewey and Harper⁶ was first tried. The quartz washer was ground to optical flatness and the gold washers were pressed between plane paralleled steel blocks which had been lapped until they were optical flats. The illium surfaces which bear on the gold were ground as

6. P. H. Dewey and D. R. Harper, III, *ibid.*, 21, 457 (1938)

true as possible, yet no permanent tight seal could be obtained even when Sauereisen insulating cement was used between the gold washers. We finally learned that workers at the Bureau of Standards had had the same trouble with all such assemblies except the first and abandoned them.

The body of the present electrode (see Fig. 1) is a conical piece of illium which clears the body of the bomb by 1/32 inch, thus shielding the teflon gasket from the combustion zone.

The gold gasket between the top and body of the tomb was replaced by a teflon gasket.

In the determination of the energy equivalent of the calorimetric system, the time of energy input was measured on a clock activated by the output from a vacuum tube precision fork (General Radio Company). The circuit is arranged so that the heating and timing are switched on and off simultaneously. The error in the timing was estimated as 0.03 second, and the heating time was 300 seconds.

Calibration. - In a series of six determinations, the mean energy equivalent for the system was $128,386.3 \pm 27.8$ joules per ohm, with a maximum deviation from the mean of 41.0 joules per ohm.

As a check, the heat of combustion of benzoic acid (standard sample N.B.S. 39F) was determined. In four determinations, the heat produced in the bomb process at 30° was found to be $26,426.2 \pm 6.4$ joules per gram of benzoic acid burned. Jessup^{7,8} reports

7. R. S. Jessup, *ibid.*, 36, 421 (1946)

8. R. S. Jessup, *ibid.*, 29, 247 (1942)

a mean value of $26,427.3 \pm 2.7$ joules per gram.

On Burning Volatile Liquids. - Initially a soft glass bulb, heat-flattened on both sides, with a capillary neck was used for the sample since such bulbs (weight between 10 and 100 mg.) had proved reasonably satisfactory in burning liquid hydrocarbons^{1,6,9,10}.

9. R. S. Jessup, *ibid.*, 18, 115 (1937)

10. J. Coops, D. Mulder, J. W. Dianske and J. Smittenberg, *Rec. trav. chim.*, 66, 153 (1947)

In theory, when a slight excess pressure is exerted on a bulb, weighing less than 120 mg. the internal volume of the bulb is reduced until the liquid sample supports the excess pressure. The flexibility of the flattened sides allows the initial distortion without breakage. This is true, but only under strictly limited conditions.

In tests made on the bulbs an excess pressure of 0.1 atmosphere outside a sample bulb of 1 ml. capacity, weighing 80-100 mg. caused the meniscus to rise approximately 1 mm. in a 1 mm. capillary. Most of the bulbs tested broke when the excess pressure reached 0.3 to 0.5 atmosphere. Thus an excess pressure of 0.1 atmosphere produced a change in volume of 0.0008 ml. and the change of volume possible without breaking the bulb is between 0.0024 and 0.0040 ml.

When an external pressure, P_2 , is exerted on a bulb of volume V , which contains a volume, v_s , of liquid and a volume, v_g , of non-condensable gas, the liquid will support the external pressure when V has been reduced by an amount equal to

$$\Delta V = v_s B_s (P_2 - P_1) + v_g (1 - P_1/P_2) \quad (1)$$

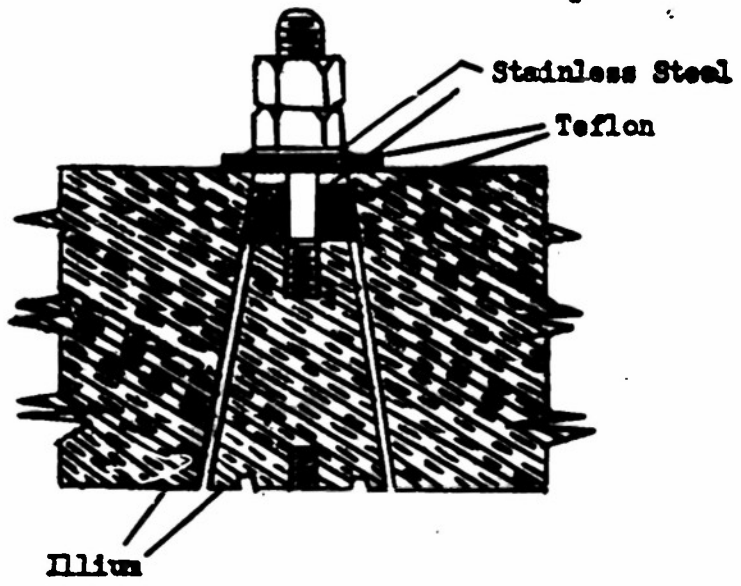

Fig. 1 - New electrode assembly

where B_g is the coefficient of compressibility of the liquid.

According to equation (1), if a bulb of the dimensions given above be filled with acetone ($B_g = 1.11 \times 10^{-4}$) and sealed off under nitrogen 2 mm. above the level of the liquid the change in volume necessary so that the acetone would support an external pressure of 30 atmospheres is 0.0048 ml. Since this value of ΔV is larger than that which the flexibility of the bulbs would normally allow, the bulb should break as the bomb is being charged with oxygen.

Were it experimentally feasible the conditions could be improved by reducing v_g , although if the coefficient of compressibility in the higher part of the usual range the bulb would break even if v_g were zero.

When the bulb was filled with acetone, the bomb charged with oxygen, and the sample fired in the normal manner, it appeared from the nature of the combustion that the bulb had functioned properly although according to the above calculation breakage must have occurred when the oxygen was introduced.

When bulbs weighing between 75 and 175 mg. were filled with hydrazine the bulbs broke during filling and the sample ignited spontaneously or did not burn at all.

Coops and his co-workers¹⁰ actually tested thin bulbs (about 100 mg.) by submitting them to 35 atmospheres of oxygen pressure without firing them. On reopening the bomb some of these bulbs were still intact. This could be due to a summation of favorable factors (e.g., the compounds they studied had lower compressibilities) in equation (1) as well as fortuitously favorable structural details in the glass bulb.

Since acetone or liquid hydrocarbons do not usually react with the oxygen even after the bulb breaks, whenever the sample is fired successfully the breakage escapes detection but is unimportant because with the bulb practically full of liquid breakage occurs without shattering.

The bulb chosen is a soft glass cylindrical bulb with a rounded end and a capillary neck (weight, 500 mg.; diameter of cylindrical part, 10 mm; over-all volume 0.5 ml.).

Since a bulb of this size is not readily broken with a small fuse wire, as an auxiliary ignitor, a thin pellet of benzoic acid (standard sample, N.B.S. 39F), is placed in the crucible with the sample. The average weight of the benzoic acid pellet is 0.1 g. and of the hydrazine sample is 0.6.

When pure hydrazine was burned with benzoic acid, a dark residue was detected after a combustion, both in the crucible and on the walls of the bomb. It is quite probable that the hydrazine sample is ignited before the benzoic acid pellet has burned completely. When the unburned benzoic acid strikes the wall of the bomb it is cooled enough to cause incomplete oxidation and the residue remains on the wall. Since it would be very difficult to weigh this unburned residue, it is necessary to depend on the carbon analysis to determine the extent of combustion.

Preparation and Purification of Samples. - The methyl substituted hydrazine samples were prepared according to the methods outlined in reference 11. The methylhydrazine was then purified and used for heat capacity determinations².

11. "Organic Syntheses", Coll. Vol. II, John Wiley and Sons, Inc., New York, N. Y. 1943, pp. 395, 211, 208.

From melting point data taken during the heat capacity determinations the methylhydrazine was shown to contain 0.25 mole per cent. impurity. Difficulties in removing this sample from the calorimeter necessitated further purification of the methylhydrazine used for combustion determinations by distillation through a forty-plate column packed with glass helices, and maintained at a pressure of 680 mm. using oxygen-free nitrogen.

No calorimetric melting point data have, as yet, been determined on this newly purified methylhydrazine. Since, however, the column proved very effective in a test distillation of acetonitrile, it is assumed that the methylhydrazine fraction used has less impurity than stated above.

The symmetrical dimethylhydrazine sample was that used in the heat capacity measurements³. From the data taken during melting it was found to be 99.6% pure.

The final purification of the unsymmetrical dimethylhydrazine sample consisted also in distillation through the column used for the methylhydrazine sample. Since the heat capacity data have not yet been taken, its exact purity is not known, but the impurity should be less than 0.5%.

RESULTS

The value reported by Hughes, Corruccini and Gilbert¹ for the heat of combustion of hydrazine at 25° is 148,635 ± 30 cal./mole. The value determined in this Laboratory, using benzoic acid as an auxiliary ignitor, is 148,619 cal./mole. This we consider as a check on the technique employed.

The results are listed in Table I. The amount of benzoic acid burned was derived from the carbon analysis. Only those experiments in which the ratio CO₂ (experimental)/CO₂ (calculated) is 99% or above have been considered. It is assumed that the low carbon analyses are due solely to the incomplete combustion of benzoic acid (that is, that the hydrazine sample burned completely).

The final value for the heat of combustion under the conditions of the bomb process (initial pressure, 30 atmospheres; final temperature, 30°) for methylhydrazine is 311.711 ± 0.144 kcal./mole, and for unsymmetrical dimethylhydrazine it is 472.648 ± 0.699 kcal./mole. In the case of symmetrical dimethylhydrazine, a preliminary value is given as 473.454 kcal./mole. The accuracy does not justify the correction outlined by Washburn¹².

12. E. W. Washburn, J. Research Natl. Bur. Standards., 10, 529 (1933)

On investigation after heat of combustion determinations using the compounds discussed previously, the sample bulb was found either fused or more often shattered. After symmetrical dimethylhydrazine combustions (about fifteen runs were attempted on this compound) the bulb was in some cases so badly shattered that it appeared powdered. This indicated a tendency for the latter sample to burn more violently. Such a tendency could explain the fact that only one combustion resulted in a reasonable carbon analysis. This determination alone is used to calculate the value reported here; however, all other values lay within 1% of this mean.

The errors are estimated on the basis that the correction for unburned benzoic acid is good to only 20.0% of its value, and that compared to this, all other errors are negligible. As a matter of fact the deviation from the mean is roughly proportional to this correction. Accordingly, the average deviation from the mean is given as the error.

Table I

Heats of Combustion

Substance burned	Mass of sample, g.	Total heat produced Int. joules	Nitric acid formation Int. joules	Ignition energy Int. joules	CO ₂ (exp.)		Heat produced by combustion of benzoic acid burned Int. joules	Observed heat of combustion Int. joules/g.
					CO ₂ (calc.)	per cent		
Methyl- hydrazine	0.47705	16648.5	-114.6	-40.2	99.47	2982.8	28321.8	
	.50908	16905.8	-78.9	-56.6	99.88	2362.3	28302.0	
	.52533	19894.5	-84.6	-51.4	99.81	4901.3	28281.7	
						Mean	28301.9 ± 13.1	
Diam- methyl- dimethyl- hydrazine	.34469	16840.4	-92.1	-33.7	99.83	5361.4	32937.4	
	.42847	17571.4	-72.9	-45.6	99.84	3354.1	32905.0	
	.38349	14654.3	-66.7	-50.8	100.09	1918.0	32905.2	
	.41091	19752.7	-86.1	-43.3	99.22	6044.5	33045.7	
						Mean	32948.3 ± 48.7	
<u>SYM</u> -Dimethylhydrazine ^a	.71346	26091.5	-80.9	-48.6	99.92	2414.6	33004.5	

^a This was the only run of 15 which gave satisfactory combustion.

"The Entropy and Configuration of Methylhydrazine"

G. J. Janz and K. E. Russell

The School of Chemistry and Physics, Pennsylvania State College,
State College, Pennsylvania

The theoretical treatment of Penney and Sutherland¹ indicates that the most stable form of hydrazine should be a skew form as opposed to the symmetrical trans configuration. The recent entropy study on this compound by Scott, Oliver, Gross, Hubbard, and Huffman²

-
1. Penney and Sutherland, Trans. Faraday Soc., 30, 902 (1934); J. Chem. Phys., 2, 492 (1934)
 2. Scott, Oliver, Gross, Hubbard, and Huffman, J. Am. Chem. Soc., 71, 2293 (1949).
-

is in accord with this. The present communication concerns methylhydrazine which is theoretically capable of existing in a trans form and two skew forms as shown in Fig. 1. It is possible to investigate the number of forms present by a comparison of experimental and calculated entropies of the ideal gas. The results of such an investigation³

-
3. Aston, Fink, Janz and Russell (to be published)
-

together with evidence from dipole moment data are reported in this letter. A summary of the experimental results is given in Table I.

Possible residual entropy at absolute zero has been neglected². The results of calculations of the entropy from molecular structure and spectroscopic data are given in Table II for an equimolar mixture of the two optical isomers of the "outer" skew form.

The vibrational entropy contribution was calculated using an assignment made on the basis of work done by Kahovec and Kohlrausch⁴ and of infra-red and Raman studies in this

-
4. Kahovec and Kohlrausch, Zeits. f. physik. Chemie., B38, 96 (1938)
-

college. The entropy contributions for restricted internal rotation were taken from the tables of Pitzer and Gwinn⁵, barriers of 3200 cal./mole for the methyl group

-
5. Pitzer and Gwinn, J. Chem. Phys., 10, 428 (1942)
-

(CH₃ vs. NHNH₂) and 3000 cal./mole for the amino group (NH₂ vs. NHCH₃) being taken as best values. The symmetry of the potential energy barrier of the NH₂ group is assumed very nearly a symmetrical threefold cosine-type^{1,2}. While from stereochemical considerations one would expect the "outer" form to be more stable than the "inner", one would expect a certain percentage of each of the two optical isomers of the "inner" form in the equilibrium mixture. In keeping with this, the experimental and calculated entropies reported above are brought into agreement if methylhydrazine be assumed to consist only of a mixture of 92 mole percent and 8 mole percent of the "outer" and "inner" forms respectively (entropy of mixing, 0.57 e.u.). This result gives a value of E₀ between the "outer" and "inner" forms as calculated from the relationship:

$$E_0 = -RT \ln \frac{N(\text{inner})}{N(\text{outer})} \text{ of about } 1450 \text{ cal./mole.}$$

It is evident that the above conclusions are dependent on the barriers hindering the internal rotation of the methyl and amino groups. Only if the barriers are chosen as 2700 cal./mole and 2050 cal./mole for the methyl and amino hindered rotation respectively (and these are reasonable minimum values corresponding to S° int. rot., 4.32 e.u.) does the entropy calculated for the "outer" isomers alone correspond to the calorimetric entropy (i.e., the "inner" and trans structures are not allowed). Again if the barriers are 3500 and 3400 cal./mole respectively for the methyl and amino groups (which are probably maximum values, giving S° int. rot. as 3.41 e.u.) the calculated entropy is in agreement with the experimental value if methylhydrazine vapor consists of a mixture of 8% mole percent of the "outer" form and 16 mole percent of the "inner" form (entropy of mixing, 0.91 e.u.), the E_0 between these being then about 1000 cal./mole.

The dipole moments were calculated assuming the net moment may be compounded vectorially from the bond moments. The results are summarized below:

"Inner" configuration	"Outer" configuration	Observed moment ⁶
$\mu = 1.13$ D	$\mu = 1.91$ D	$\mu = 1.68 \pm 0.14$ D

6. Ulich, Feisker, and Audrieth, Ber. d. d. chem. Ges., B68, 1677 (1935)

The dipole moment calculated for the trans-configuration is even less than that for the "inner" skew configuration. These results are therefore in accord with the entropy study, namely that methylhydrazine exists predominantly in the skew "outer" form with its methyl group farthest from the hydrogens of the NH_2 group.

This is a preliminary report of part of the program being carried out on Contract N6onr 269, Task Order III of the ONR under the direction of Professor J. G. Aston whose advice we have frequently sought in these calculations.

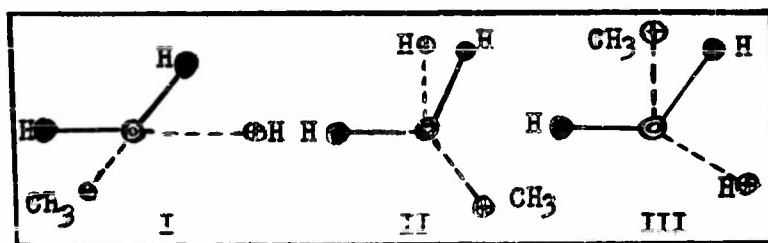

Fig. 1

End-on view of methylhydrazine. I-Trans form. II-"Outer" skew form.
III-"Inner" skew form.

Table I

	E.U./Mole
0-15°K Debye function ($\nu = 193$, six degrees of freedom)	0.073
15-220.79°K (graphical)	18.780
Fusion (2490.5/220.79)	11.279
220.79-298.16°K (graphical)	9.530
Entropy of liquid at 298.16°K	39.662 \pm 0.07
Vaporisation (9650.3/298.16)	32.366 \pm 0.11
Entropy of real gas at 298.16°K/49.6 mm	72.028 \pm 0.18
Entropy of ideal gas	72.036 \pm 0.18
Compression $R \ln (49.6/760)$	-5.423 \pm 0.02
Entropy of ideal gas at 298.16°K/760 mm.	66.61 \pm 0.20

Table II

S° translational	37.393
S° ext. rot.	22.094
S° vibrational	1.418
S° int. rot. (CH_3 and NH_2)	3.751
S° mixing (2 o. isomers)	1.379
Total entropy (ideal gas, 298.16°K/760 mm.)	66.04 e.u.

Copied from the Journal of the American Chemical Society, 73, 1939 (1951)

Contribution from the School of Chemistry and Physics, The Pennsylvania State College

"The Heat Capacity, Heats of Fusion and Vaporization, Vapor Pressures, Entropy and Thermodynamic Functions of Methylhydrazine" ¹

By J. G. Aston, H. L. Fink, G. J. Janz and K. E. Russell

The entropy of methylhydrazine vapor in the ideal gas state has been calculated from heat capacity measurements down to 14.5°K., heats of fusion, heats of vaporization and the vapor pressure. This has been compared with that calculated from the spectroscopic and molecular data on the basis of alternate assumptions concerning the ratios of the amounts of rotational isomers. The outer form apparently predominates.

INTRODUCTION

Investigations of the thermodynamic properties of the various methyl-substituted hydrazines are in progress in this Laboratory. This paper presents the experimental results on methylhydrazine, together with a discussion of the configuration of the molecule in the gaseous state based on a comparison of the calorimetric entropy with that calculated from spectroscopic and molecular data.

EXPERIMENTAL

The Methylhydrazine Sample.- The methylhydrazine was prepared according to the method of "Organic Syntheses" ². Benzalazine was prepared from hydrazine, and converted

1. This research was carried out on Contract N6omr-269, Task Order 3, of the Office of Naval Research.
2. "Organic Syntheses", Coll. Vol. II, John Wiley and Sons, Inc., New York, N. Y. 1943, p.395

to the methylhydrazine sulfate by reaction with dimethyl sulfate. The salt was decomposed with base, and the methylhydrazine distilled in an atmosphere of nitrogen. The sample was further purified by the method of fractional melting ³ in a glass apparatus. It was shown to contain 0.25 mole per cent. impurity from its melting point curve, assuming all impurity to be solid insoluble.

3. Aston and Mastrangelo, Anal. Chem., 22, 636 (1950)

Apparatus.- The experimental measurements were made in an adiabatic calorimeter with a valve in the outlet line at the shield. This is described in Fig. 1 with explanatory legend. The calorimeter and valve is similar to one designed by R. B. Scott of the National Bureau of Standards, ^{4a} and except for the valve, to others of this Laboratory ^{4b,c}.

- 4a. R. B. Scott, et. al., to be published; see also Osborne and Ginnings, J. Research Natl. Bur. Standards, 39, 453 (1948); (b) Aston and Szasz, THIS JOURNAL, 69, 3108 (1947); (c) Morrison and Szasz, J. Chem. Phys., 16, 280 (1948)

Henceforth it will be designated as calorimeter F. The valve seat is of stainless steel, and the closure disk of brass which has been tin plated. The valve is opened and closed by means of a thumb screw which gives fine control of a lever system. The valve prevents

evaporation of the sample into the filling line and hence eliminates corrections to the heat capacities from this cause. It is also used to control the rate of flow of vapor during heats of vaporization. With the valve located on the shield the vaporization process does not include any effect of expansion at the valve.

An electronic circuit was designed to control accurately the temperature of the tube and two shields. When necessary this could replace manual operation.

A means of switching, in turn, the three control thermocouple voltages into a single Perkin Elmer d.c. amplifier was provided. This is made possible by the low period (1/6 sec.) of the amplifier. A motor drives two single pole triple throw switch elements. One switch element controls the input side of the amplifier (directly from the thermocouple) and the other switch element controls the output side of the Perkin Elmer d.c. amplifier (to the electronic amplifier circuit). These two switches had to be phased so that the input contact was made before the output and then the output contact broken before the input. The switches are carefully shielded to exclude stray electro-motive forces. The signal received from the amplifier is stored in a condenser, for each circuit, which then controls an electronic circuit in which the output of 6L6 tubes is used to heat the various elements of the calorimeter assembly.

A schematic diagram showing the various connections used in the control circuit and calorimeter, etc., is given in Fig. 2. It is sometimes necessary to maintain a small temperature difference between the shields and the calorimeter. This is done by adding a small bias voltage ("balance controller") to the signal from the difference thermocouples. The control panel is arranged so that the heating current for the shields and tube is set to a higher value on switching the calorimeter heating current on. This is done by exchanging the resistance in the output circuit of the 6L6 tubes for a lower one. The time of energy input was measured on a clock driven by the output from a General Radio Company vacuum tube precision fork. The switches for the heating current and for the clock were so connected that the heating circuit and the timing circuit were switched on and off simultaneously.

The Temperature Scale.— Below 90°K. the calorimeter platinum resistance thermometer PT. G-9, was calibrated, as previously described^{4b,c} against the laboratory standard thermocouple S-3 which was fastened to the calorimeter. The indications of the thermocouple, S-3 were compared with temperatures from vapor pressures of hydrogen condensed in the calorimeter before the measurements were made. The change from the original calibration ($T_{S-3} - T_{obs}$) was 0.42° at 20.3°K. A corresponding correction in microvolts was applied to the original calibration on the assumption that this was proportional to the total microvolt reading. Above 90°K. the International Temperature was used as determined by the readings of PT. G-9 at the oxygen, ice, steam and sulfur points. This scale agreed with that of the thermocouple, with its indications thus corrected, within experimental error (0.02°).

The Heat Capacity Measurements.— The smoothed values of the heat capacity at integral temperatures, read from the best curve through the experimental points, are listed in Table I. The precision of the results from 30 to 298°K. is 0.2%, but between 20 and 30°K. it is 0.3%, and below 20°K. the error may rise to as much as 2.5%. The uncertainty in the region 15-20°K. is due in part to the difficulty in maintaining the system adiabatic, because of the heat leak through the filling tube and valve. The heat capacity curve was extrapolated from 190°K. to the melting point (220.79°K) because of the premelting which occurs in this region, and this may give rise to an error of 0.5% in the heat capacities at the melting point.

The small volume above the methylhydrazine in the calorimeter and the low vapor pressure even at 298.16°K (49.6 mm.) made it unnecessary to correct for the amount of material in the vapor space. However, there was some polymerization as indicated by the heat capacity of the empty calorimeter which had risen several tenths of a per cent after the first series of measurements. A correction was applied based on the amount of sample which could be removed. The uncertainty in this correction could affect

Table I

Heat Capacity of Methylhydrazine

Mol. wt. 46.074; 0°C. = 273.16°K; 1 cal. = 4.1833 int. joules

T, °K.	C _p	T, °K.	C _p
	Crystal	130	12.21
15	0.436	140	12.84
20	1.007	150	13.45
25	1.646	160	14.05
30	2.349	170	14.67
35	3.081	180	15.34
40	3.830	190	15.98 ^a
45	4.570	200	16.60 ^a
50	5.220	210	17.20 ^a
55	5.835	220	17.80 ^a
60	6.420	220.79	17.84 ^a crystal
65	6.984		Fusion
70	7.531	220.79	31.27 liquid
75	8.085	230	31.40
80	8.570	240	31.52
85	8.996	250	31.64
90	9.389	260	31.76
95	9.760	270	31.88
100	10.13	280	32.01
110	10.83	290	32.14
120	11.52	298.16	32.25

^a Values extrapolated.

the accuracy of the results by as much as one per cent. in some regions but much less at others. The maximum effect on the entropy could not exceed 0.3 e.u.

The Melting Point and Heat of Fusion.— Equilibrium temperatures of solid and liquid methylhydrazine were observed with increasing fractions of the sample melted. From these results, the solid-insoluble impurity was found to be 0.25 mole per cent. A similar value was calculated from the premelting heat capacities showing that there was little or no solid soluble impurity in the sample. The melting point of pure methylhydrazine, obtained by correcting the melting point of the sample for the presence of 0.25 mole per cent. impurity is 220.79°K.

The results of the heat of fusion measurements are given in Table II. The usual corrections for premelting and for heating the solid and the liquid have been applied ^{4b}. They were obtained during the heat capacity measurements as previously described.

The Vapor Pressures and Heats of Vaporization.— The vapor pressure of methylhydrazine at 298.16°K. is required for the calculation of the entropy of compression term to 1 atmosphere. A series of readings of vapor pressures against temperatures, taken in the usual manner, ^{4b} are reported in Table III. The deviations of the values in column 2 from equation 1, given at the foot of the table, are given in column 3. These are much larger than usual, possibly due to lack of equilibrium caused by adsorption on the glass capillary and walls of the manometer, possibly due to slight condensation. The vapor pressure interpolated at 298.16°K. by this equation is 49.6 mm.

Heats of vaporization were obtained directly by introducing measured quantities of heat into the calorimeter and collecting the methylhydrazine vaporized in weighed bulbs surrounded by liquid air as described for the heat of vaporization of trimethylamine at 25°K ⁵. The temperature of vaporization, as measured on a standard thermocouple

5. Aston, Sagenkahn, Szasz, Messen and Zuhr, THIS JOURNAL, 66, 1171 (1944)

attached to the calorimeter, was maintained constant by controlling the valve instead of the grooved stopcock described previously. The filling tube and valve were held at a higher temperature than the calorimeter to prevent condensation in the line, and corrections for the heat leak from this cause and from the shields were applied. The vaporizations were taken at temperatures close to 25° and the heats of vaporization at 25° were calculated using a value of the heat capacity of the vapor obtained from spectroscopic data and assumed barriers for internal rotation. The results are given in Table IV. A value calculated from equation (1) and thermodynamics is also included as a test of this equation only. Its accuracy is not to be compared with that of the measured values.

The Entropy from Calorimetric Data.— The calculation of the entropy of methylhydrazine from calorimetric data is summarized in Table V. The small correction for gas imperfection was made using the Berthelot equation,

$$FV = RT \left[1 + \frac{9PT_c}{126F_c T} \left(1 - 6 \frac{T_c^2}{T^2} \right) \right] \quad (2)$$

with assumed critical constants of $T_c = 530^\circ\text{K}$ and $P_c = 75$ atm. Although the critical constants and the Berthelot correction itself are only estimates, the uncertainty is probably less than 0.005 e.u.

DISCUSSION

Thermodynamic Functions from Spectroscopic and Molecular Data.— Rotational isomerism in methylhydrazine can give rise to a trans form and two skew forms. It has been shown in the case of hydrazine that the trans form is excluded ⁶ and it is

6. Penney and Sutherland, Trans. Faraday Soc., 30, 902 (1934); J. Chem. Phys., 2, 492 (1934)

probable that the same result applied to methylhydrazine ⁷. The skew form of

Table II

Heat of Fusion of Methylhydrazine

Mol. wt. 46.074; $0^{\circ}\text{C} = 273.16^{\circ}\text{K}$; melting point = 220.79°K ; 1 cal. = 4.1833 int. joules

Temp. interval	Cor. heat input cal./ mole	$C_p dT$, cal./ mole	Pre- melt- ing, cal./ mole	H cal./mole
205.007-221.763	2970.8	-489.2	+ 8.2	2489.8
214.688-222.584	2701.9	-252.9	+42.2	2491.2

Mean 2490.5 ± 3 cal./mole

Table III

Vapor Pressure of Methylhydrazine

g State College = $980.124 \text{ cm./sec}^2$ "I.C.T.", $0^{\circ}\text{C} = 273.16^{\circ}\text{K}$.

$T^{\circ}\text{K}$	$P_{\text{obs.}}$ mm.	$P_{\text{calcd.}}$ $P_{\text{obs.}}$
275.117	12.11	+0.13
284.899	22.85	+ .08
290.292	31.76	- .02
293.692	38.72	- .10
(298.16) (interpolated using eq.1)	49.63	
298.326	50.00	+ .08

Calculated from the equation: $\log_{10} P = -7.88 \log_{10} T - 3.146/T + 31.746$ (1).

Table IV

Molar Heats of Vaporization of Methylhydrazine at 298.16°K.

Mol. wt. 46.074, 0°C = 273.16°K; 1 cal. = 4.1833 int. joules

Mole vaporized	Mean temp. of vaporization, °K.	ΔH at T°K. cal./mole	ΔH at 298.16°K cal./mole
0.12022	296.69	9684	9660
.11959	297.15	9672	9655
.092195	299.39	9618	9638
.12279	302.27	9602	9669
.12440	297.96	9623	9620
			Av. 9648
Calculated from eq. (1) (Table III) and estimated critical data, $T_c = 530^\circ\text{K}$; $P_c = 75$ atm. (Berthelot correction 19 cal.)			9701

Table V

Entropy of Methylhydrazine from Thermal Data

	E.u./mole
0-15°K. Debye function	
$\Theta = 193$, six degrees of freedom	0.073
15-220.79°K, graphical	18.780
Fusion 2490.5/220.79	11.279
220.79-298.16°K, graphical	9.530
Entropy of liquid at 298.16°K	39.66 \pm 0.07
Vaporization 9648/298.16	32.36 \pm 0.11
Entropy real gas at 298.16°K	72.02 \pm 0.18
Entropy ideal gas at 298.16°K	72.03 \pm 0.18
Compression $R \ln 49.6/760$	-5.42 \pm 0.02
Entropy ideal gas 760 mm., 298.16°K	66.61 \pm 0.20

7. Janz and Russell, *ibid.*, 17, 1352 (1949), have given preliminary results of the investigation.

methylhydrazine with the methyl group farthest from the hydrogens of the amino group is termed the "outer" form, and the other is known as the "inner" form. It is considered that the outer skew form is more stable than the inner since the interactions between the hydrogens of the methyl group and the rest of the molecule are less for this form. This is assumed as the main form.

Moments of inertia of this form have been calculated using the following data: N-H, 1.45 Å; N-C, 1.47 Å; N-H, 1.04 Å; C-H, 1.09 Å,⁸ and assuming all angles to

8. W. H. Beamer, *THIS JOURNAL*, 70, 2979 (1948)

be tetrahedral. The product of the principal moments of inertia is 1.803×10^{-115} g. cm.², and the reduced moments of the methyl and amino groups are 4.32×10^{-40} g. cm.² and 2.85×10^{-40} g. cm.². The reduced moments were calculated by the method of Pitzer and Gwinn.⁹

9. Pitzer and Gwinn, *J. Chem. Phys.*, 10, 428 (1942)

The vibrational assignment has been discussed elsewhere⁷. The frequencies used in the thermodynamic calculations were 443, 770, 816, 886, 969, 1103, 1122, 1137, 1197, 1441, 1412, 1474, 1587, 2865, 2933, 2965, 3177, 3245, 3317 cm⁻¹. The frequencies corresponding to torsional oscillations were not observed directly.

In the calculation of entropy decreases due to restricted internal rotation, a three-fold cosine-type barrier was taken for the methyl hindered rotation. The shape of the barrier restricting rotation of the amino group is not known, but a barrier of the type suggested for hydrazine has been assumed with each form occupying one-third of a revolution^{10,7}. A series of possible values for the potential barriers has been

10. Scott, Oliver, Gross, Hubbard and Huffamn, *THIS JOURNAL*, 71, 2293 (1949)

chosen and in each case the calculated entropy has been brought into accord with the observed by means of the entropy of mixing of inner and outer forms. The contributions due to hindered internal rotation were calculated using the difference tables of Pitzer and Gwinn. The calculations are summarized in Table VI.

If a value of 2800 cal./mole is assigned to the barrier hindering the methyl rotation and 2650 cal./mole to that hindering the amino rotation, the calculated entropy agrees with the observed value, if the system exists entirely in the outer skew form. For barriers of 3200 and 3000 cal./mole for the methyl and amino hindered rotations respectively, the system is shown to exist as an equilibrium mixture of 96 mole per cent. outer form and 4 mole per cent. inner form (with an energy difference of 1880 cal. between the two forms). If barriers as high as 3500 and 3400 cal./mole are assigned to the methyl and amino rotations, the calculated entropy for a mixture of 92 mole per cent. outer form and 8 mole per cent. inner form agrees with the observed entropy. This corresponds to an energy difference of 1445 cal. between the two forms. If a comparison may be made with barriers reported for hydrazine, the simple aliphatic amines and hydrocarbons, it is probable that values of 3200 and 3000 cal./mole are the most reasonable. Over the whole range of barriers discussed, however, it is shown that one form predominates, leading to the conclusion that methylhydrazine exists primarily in the skew outer form.

In the foregoing discussion it has been assumed that methylhydrazine does not possess residual entropy at the absolute zero. It has been suggested that hydrazine may possess a small zero point entropy¹⁰, and it is possible that compounds such as methylamine and dimethylamine, which have been used as comparison substances for barrier

estimates, also possess a definite entropy at the absolute zero. If a zero point entropy occurs evenly through the amines and the hydrazines, however, it will change the values given for the potential barriers, but will not materially affect the above discussion concerning rotational isomers. Some additional evidence in favor of the predominance of the skew outer form for methylhydrazine may be obtained from dipole moment data. The moments for the skew forms can be calculated by vector addition of group moments. Using the values given by West and Killingsworth ¹¹ for the N-H, N-C and H-N-CH₃ group

11. West and Killingsworth, J. Chem. Phys., 6, 1 (1938)

moments and a value of 1.48 D for the H-N-H moment, the resultant moments of these forms were found to be

Inner form	Outer form	Observed ¹²
1.13D	1.92D	1.68 ± 0.14 D.

12. Ulich, Peisker and Audrieth, Ber., B68, 1677 (1935)

The moments were calculated assuming a 90° rotation from the cis-configuration, and if, as is possible, this angle is greater than 90°, the calculated dipole moment for the outer form approaches the observed value still more closely. The dipole moment was observed for a dilute solution of methylhydrazine in benzene, and it might be expected that there would be a little difference between the configuration of methylhydrazine in such a system and in the gaseous state.

Values of the free energy function, heat content function, entropy and heat capacity of methylhydrazine were calculated using the spectroscopic and molecular data already mentioned. These are listed in Table VII. In the calculation the barriers, listed under (2) in Table VI were used with an energy difference of 1880 cal. mole⁻¹ between the isomers. In some cases the values are given to more significant figures than is justified by their absolute accuracy in order to retain internal consistency among the different functions.

Table VI

Entropy of Methylhydrazine

T = 298.16°K; P = 1 atm.

	(1) V_{CH_3} 2800 V_{NH_2} 2650	(2) V_{CH_3} 3200 V_{NH_2} 3000	(3) V_{CH_3} 3500 V_{NH_2} 3400
S transitional	37.393	37.393	37.393
S vibrational	1.767	1.767	1.767
S ext. rot.	22.094	22.094	22.094
S int. rot. (CH ₃ and NH ₂)	3.985	3.679	3.421
S mixing (optical isomers)	1.377	1.377	1.377
S total (outer form)	66.61	66.31	66.05
S mixing (with inner form)	0.00	0.30	0.56
S total (mixture)	66.61	66.61	66.61
S observed	66.61	66.61	66.61

Table VII

Thermodynamic Functions for Methylhydrazine

Temp. °K	H - E ₀ cal./mole	-(F - E) ₀ /T		
		cal./deg./ mole	S cal./deg./ mole	C _p cal./deg./ mole
298.16	3,438	55.08	66.61	17.0
300	3,469	55.16	66.72	17.11
400	5,382	58.74	72.20	21.0
500	7,658	61.67	77.29	24.3
600	10,230	64.88	81.93	27.1
700	13,040	67.67	86.30	29.3
800	16,080	70.23	90.33	31.3
900	19,290	72.58	94.02	33.1
1000	22,630	74.99	97.63	34.6
1200	29,830	79.32	104.18	37.1
1500	41,420	85.28	112.90	39.8

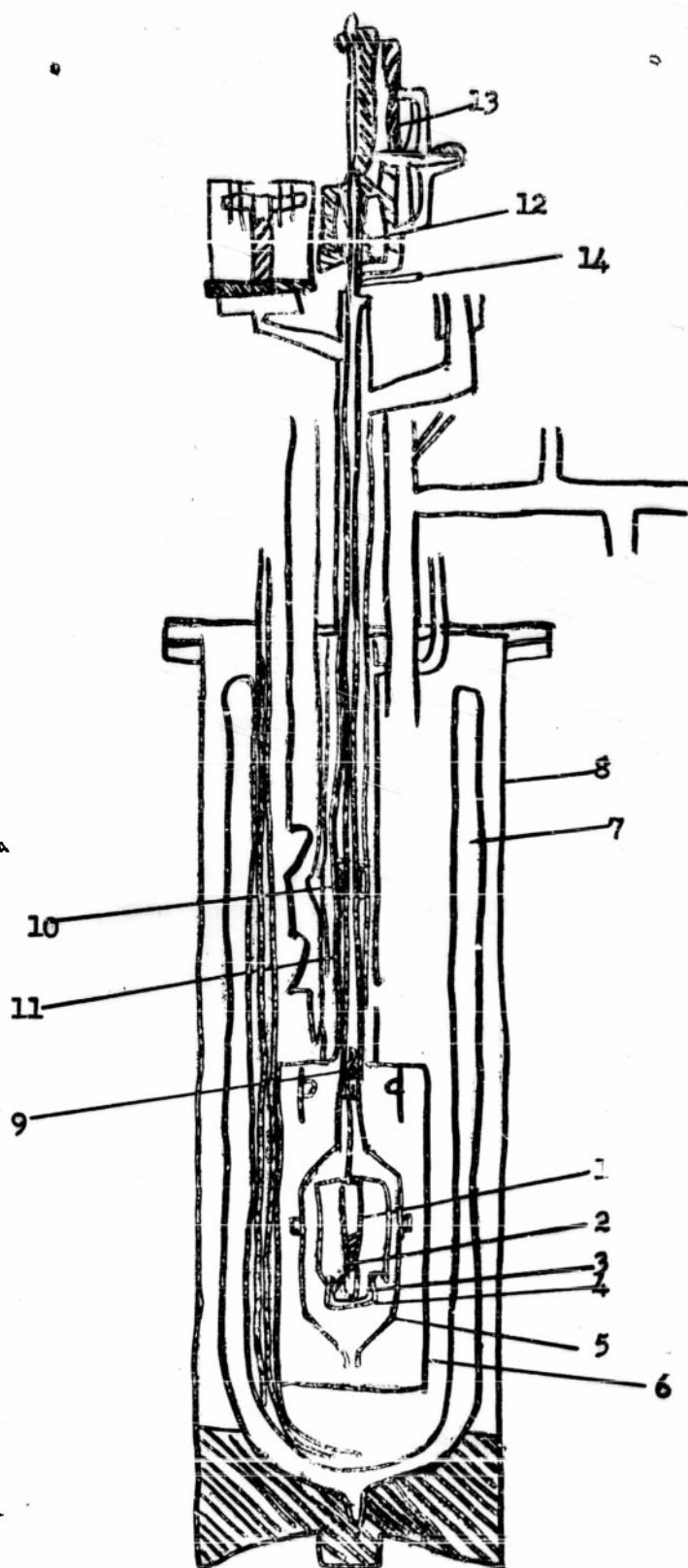

Fig. 1

1. Calorimeter vessel with vanes-about 90 cc. capacity, all of copper; gold plated outside, tinned with pure tin inside. 2. Thermometer well holding 25 ohm strain-free platinum resistance thermometer with the calorimeter heater of constantan wire wrapped bifilarly on the lower part. The thermometer and heater are cast in with Woods metal. 3. Collar, around which leads to heater and thermometer are wrapped so that any heat leaking along them from the heater is conducted back to the calorimeter. 4. Cap to cover collar and

prevent radiation from thermometer cap and leads when at higher temperature than calorimeter. 5. Shields. 6. Vacuum tight cryostat envelope. 7. Dewar for refrigerants. 8. Dewar container. 9. Stainless steel valve seat with closure disc of tin plated brass. 10. Thermal contact of valve stem with tube leading to cryostat which serves as a thermal contact with the bath. Consists of spring-like fins of brass on stem fitting into copper bearing. 11. Tube heaters. 12. Copper bellows. 13. Valve control mechanism. 14. Filling tube for calorimeter.

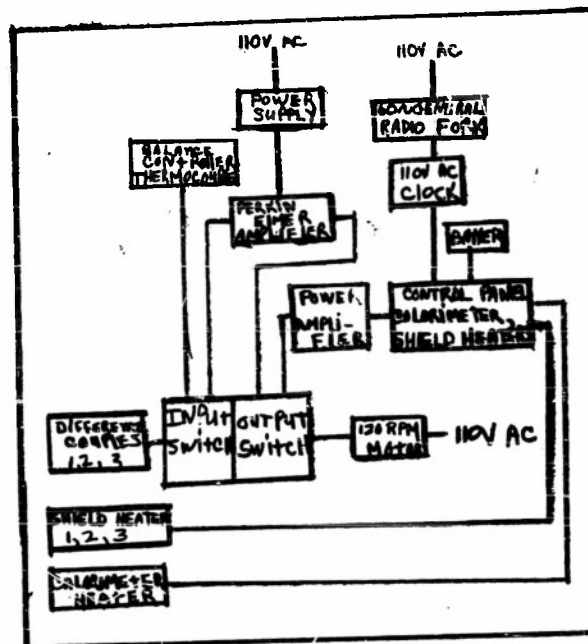

Fig. 2

Schematic diagram of electrical connections for automatic operation of adiabatic calorimeter.

[Copied from the Journal of the American Chemical Society, 73, 1943 (1951)]

[Contribution from the School of Chemistry and Physics of the Pennsylvania State College]

"The Heat Capacity, Heats of Fusion and Vaporization, Vapor Pressures and Entropy
of Symmetrical Dimethylhydrazine" ¹

by J. G. Aston, G. J. Janz and K. E. Russell

The entropy of sym-dimethylhydrazine vapor in the ideal gas state has been calculated from heat capacity measurements down to 14.5°K. heats of fusion, heats of vaporization and the vapor pressure. This has been compared with that calculated from the spectroscopic and molecular data for both the inner-outer and the outer-outer forms.

1. This research was carried out on Contract N6-onr-269, Task Order III, of the ONR

INTRODUCTION

Symmetrical dimethylhydrazine may exhibit rotational isomerism to give a number of forms analogous to the "inner" and "outer" skew forms of methylhydrazine ^{2a,b,c}.

- 2a. West and Kellingsworth, J. Chem. Phys., 6, 1 (1938)
- b. Janz and Russell, J. Chem. Phys., 17, 1352 (1949)
- c. Aston, Fink, Janz and Russell, THIS JOURNAL, 73, 1939 (1951)

This paper presents the results of a calorimetric investigation of sym-dimethylhydrazine with a discussion of the relative amounts of the rotational isomers occurring in the vapor at room temperature.

EXPERIMENTAL

The sym-Dimethylhydrazine Sample.- Symmetrical dimethylhydrazine was prepared according to the method of "Organic Syntheses", ³ liberated by the addition of base, and purified by distillation in an atmosphere of nitrogen through a column of glass helices with approximately 100 theoretical plates.

3. "Organic Syntheses", Coll. Vol. II, John Wiley and Sons, Inc., New York, N. Y. 1943, p.208.

Heat Capacity Measurements.- The measurements were taken in calorimeter F which was used for the work on methylhydrazine ². Smoothed values of the heat capacity at integral temperatures are given in Table I, extrapolated values being used from 230°K. to the melting point because of premelting. The heat capacity data are plotted against temperature in Fig. 1. There is a sharp rise of about 0.1 cal./mole in the heat capacity in the region of 138°K. (see insert at the left of Fig. 1.)

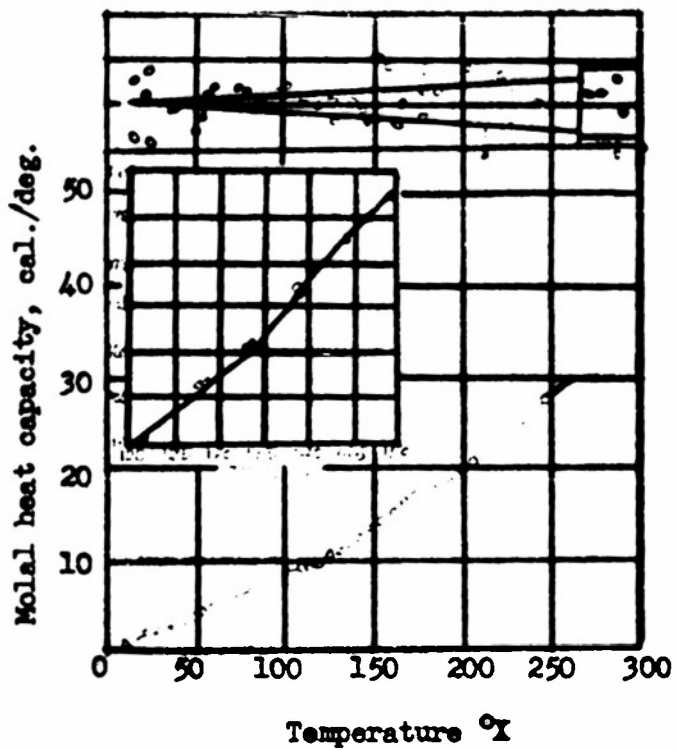

Fig. 1 - Heat capacities of dimethylhydrazine.

Table I

Heat Capacity of gas-Dimethylhydrazine at Integral TemperaturesMol. wt. 60.010; $0^{\circ}\text{C} = 273.16^{\circ}\text{K}$; 1 cal. = 4.1833 int. joules.

Temp., $^{\circ}\text{K}$	C_p cal./deg./mole	Temp. $^{\circ}\text{K}$	C_p cal./deg./mole
15	0.936	100	13.14
16	1.054	110	14.06
17	1.180	120	14.95
18	1.318	130	15.77
19	1.455	140	16.83
20	1.602	150	17.79
21	1.760	160	18.66
22	1.922	170	19.56
23	2.088	180	20.50
24	2.258	190	21.49
25	2.435	200	22.50
30	3.430	210	23.53
35	4.430	220	24.59
40	5.330	230	25.70 ^a
45	6.192	240	26.83 ^a
50	6.990	250	28.01 ^a
55	7.750	260	29.23 ^a
60	8.465	264.28	29.74 ^a Crystal
65	9.172		Fusion
70	9.854	264.28	40.31 Liquid
75	10.49	270	40.40
80	11.09	280	40.56
85	11.65	290	40.72
90	12.15	298.16	40.88
95	12.66		

^a Extrapolated.

The effect constitutes 3% of the total heat capacity, compared with a precision of about 0.2% at these temperatures as indicated by the deviation plot in the upper part of Fig. 1. It can be seen from Fig. 1 that the discontinuity does not affect the smoothness of the values in Table I below 130°K. or above 150°K. but that the first differences in this region are not in keeping with the rest in the table. If the phenomenon involves a transition, then the heat of transition must be close to zero. Heat capacities taken in the region of 138°K show an abnormal afterdrift of the order of 0.001° per minute for a period of about 2 hours.

A small amount of involatile material remained in the calorimeter from the methylhydrazine measurements, which increased the heat capacity of the calorimeter by about 1% at the higher temperature, for which a correction was made. The heat capacity measurements could be in error by several tenths of a per cent. and the entropy by about 0.3 e.u. on this account rather than by the instrumental errors listed in Table IV.

The Melting Point.— Equilibrium temperatures were observed with several fractions of the sample melted. The solid insoluble, impurity was calculated to be 0.4 mole per cent. and the calculated melting point of the pure material is $264.24 \pm 0.04^\circ\text{K}$. The concentration of impurity was also estimated to be 0.4 mole per cent. from premelting heat capacities indicating the presence of little or no solid-soluble impurity. This included the involatile material mentioned above.

The Heat of Fusion.— The results of the heat of fusion measurements on sym-dimethylhydrazine are summarized in Table II. They were taken during the course of the heat capacity measurements and the usual corrections have been applied ^{2c}. One of the results was obtained in conjunction with the purity determination.

Heats of Vaporization and Vapor Pressures.— Measurements were made as for methylhydrazine ². As a result of five determinations listed in Table III, the heat of vaporisation of sym-dimethylhydrazine was found to be 9,400 cal./mole at 25°. The vapor pressures below 25°, taken as described previously ², are given in Table IV, column 2, along with the deviations (column 3) from equation (1) given at the foot of the table. These are larger than usual, possibly due to the slow adsorption

Table II

Heat of Fusion of sym-DimethylhydrazineMol. wt. 60.010; $0^{\circ}\text{C} = 273.16^{\circ}\text{K}$; 1 cal. = 4.1833 int. joules; melting point 264.28°K

Temp. interval $^{\circ}\text{K}$	Heat input cal./mole	$C_p dT$ cal./mole	Pre-melt- ing, cal./mole	ΔH fusion, cal./mole
245.106-266.167 ^a	4126.3	876.2	10.5	3260.6
242.844-266.387 ^b	4243.6	993.7	7.6	3257.5
243.758-266.409 ^b	4205.2	952.1	7.3	3260.4
				Mean $\Delta H = 3295.5 \pm 5$ cal/mole

^a Obtained in conjunction with purity determination Integral heat of fusion.

Table III

Molal Heats of Vaporization of sym-DimethylhydrazineMol. wt. 60.010; $0^{\circ}\text{C} = 273.16^{\circ}\text{K}$; 1 cal = 4.1833 int. joules

Mole vaporized	Mean temp. of vaporization $^{\circ}\text{K}$	ΔH real gas $^{\circ}\text{K}$	ΔH real gas 298.16°K cal./mole
0.093236	296.46	9441	9404
.093.136	298.97	9388	9406
.093329	298.60	9375	9385
.092230	298.50	9393	9401
.091609	297.81	9410	9402
			Average 9400 \pm 15

Calculated from equation (1), Table IV, and estimated critical data, $T_c = 530^{\circ}\text{K}$, $P = 90$ atm. (Berthelot correction = 21 cal.)

processes. To give an idea of the accuracy, the heat of vaporization calculated from equation (1) is given at the foot of Table III. The accuracy of this value, of course, does not compare with the measured one. In its calculation the vapor volumes were estimated using the modified Berthelot equation and the estimated critical constants, $T_c = 530^\circ\text{K}$. and $P_c = 90$ atmospheres. Equation (1) yields a value of 70.1 mm. for the vapor pressure at 298.16°K (Table IV). This result has been used in the calculation of the entropy correction to one atmosphere.

Entropy from the Thermal Data.- The entropy calculation is summarized in Table V. A correction for gas imperfection has been made using the Berthelot equation and assumed critical constants of $T_c = 530^\circ\text{K}$, $P_c = 90$ atmospheres. As with methylhydrazine, the uncertainty is less than 0.005 e.u.

DISCUSSION

The Entropy from Spectroscopic and Molecular Structure Data.- The most probable forms of symmetrical dimethylhydrazine are the three skew forms ^{2a}, with the outer-outer, the inner-outer, and the inner-inner placement of methyl groups. From stereo-chemical reasoning it is likely that the amount of the inner-inner form in the vapor at room temperature is small, so that the two low energy forms are the outer-outer and the inner-outer.

The moments of inertia were calculated using the following bond distances, N-N, 1.45 Å; C-N, 1.47 Å; C-H, 1.09 Å; N-H, 1.04 Å, and assuming all angles to be tetrahedral. The product of the principal moments of the outer-outer form is 1.309×10^{-114} (g. cm²)³. The reduced moment of the methyl group is 4.524×10^{-40} g. cm² for the outer-outer form, and the reduced moment of the methyl-amino group is 1.636×10^{-39} g. cm². For the inner-outer form, the product of the principal moments is 1.573×10^{-114} (g. cm²)³ and the reduced moments of the methyl and methylamino groups are 4.986×10^{-40} g. cm² and 1.897×10^{-39} g. cm², respectively. The moments of the methylamino group were calculated by the method of Pitzer ⁴. The symmetry number for

4. Pitzer, J. Chem. Phys., 14, 239 (1946)

Table IV

Vapor Pressures of sym-Dimethylhydrazine
 $0^{\circ}\text{C} = 273.16^{\circ}\text{K}$; $g(\text{State College}) = 980.124 \text{ cm./sec.}^2$ "I.C.T."

Temperature, $^{\circ}\text{K}$	Vapor pressure mm.	$P_{\text{calcd}}^a - P_{\text{obsd.}}$
274.531	17.01	+0.33
282.892	29.19	+0.23
288.970	42.49	- .37
294.067	56.13	- .04
297.617	67.99	- .05
298.16 (extrapolated using eq. 1)	69.9	

^a Calculated using the equation: $\log_{10} P = -10.540$
 $\log_{10} T - 3207.0/T + 39.352$ (1).

Table V

Entropy of sym-Dimethylhydrazine from Thermal Data

	E.u./mole
0-15 $^{\circ}\text{K}$ Debye function ($\theta = 118.3^{\circ}$ of freedom)	0.306 \pm 0.02
15 $^{\circ}\text{K}$ -264.28 $^{\circ}\text{K}$, graphical	30.055 \pm 0.07
Fusion (3259.5/264.28)	12.334 \pm 0.02
264.28-298.16 $^{\circ}\text{K}$	4.903 \pm 0.01
Entropy of Liquid at 298.16 $^{\circ}\text{K}$	47.598 \pm 0.12
Vaporization (9400/298.16)	31.527 \pm 0.05
Entropy real gas at 298.16 $^{\circ}\text{K}$ and 69.8 mm	79.125 \pm 0.17
Entropy ideal gas at 298.16 $^{\circ}\text{K}$ and 69.8 mm.	79.135 \pm 0.18
Compression $R \ln (69.9/760)$	-4.740 \pm 0.01
Entropy ideal gas at 760 mm and 298.16 $^{\circ}\text{K}$	74.39 \pm 0.2

for the external rotation is unity for the inner-outer form and two for the outer-outer form.

The frequencies used in the calculation of the vibrational entropy contribution were 422, 483, 720, 801, 955, 1019, 1045 (2), 1099, 1114 (2), 1132, 1197, 1405 (2), 1456 (2), 1476 (2), 2824, 2845, 2916 (2), 2946 (2), 3223, 3294 cm^{-1} 5.

5. Axford, Janz and Russell, to be published.

Approximate barriers of 3000 cal./mole have been assigned to the hindered rotation of both the methyl and methylamino groups. The calculations are summarized in Table VI.

Two alternatives are allowed by the entropy study. The entropy calculated for the inner-outer form is equal to the observed entropy within the limits of experimental error. One possibility is therefore that sym-dimethylhydrazine vapor at 25° consists almost entirely of the inner-outer form. Supporting evidence comes from dipole moment data.¹ West and Killingsworth¹ conclude that sym-dimethylhydrazine is predominantly in the inner-outer form.

The entropy study allows a second alternative. A mixture of about 70 mole per cent outer-outer form with 30 mole per cent. inner-outer form gives an entropy equal to the observed value. This corresponds to an energy difference of about 1000 cal. between the two forms. If such a high proportion of a second form were also present in liquid sym-dimethylhydrazine at room temperature, it would be expected that the Raman spectrum would contain lines due to both forms. Spectra taken at two different temperatures might show variations in relative intensities of some lines, giving evidence for this second alternative.

The above discussion assumes that sym-dimethylhydrazine does not possess a zero-point entropy. The barriers to internal rotation are not known exactly, although the values chosen are probably not in serious error.

Table VI

Entropy of syn-Dimethylhydrazine from Molecular Data

	Outer-outer form	Inner-outer form
S translation	38.186	38.186
S vibration	2.850	2.850
S ext. rotation	22.692	24.253
S methyl internal rotation	4.194	4.370
S methylamino internal rotation	3.294	3.436
S mixing optical isomers	1.377	1.377
S total, e.u.	72.59	74.47
S observed, e.u.	74.39	74.39

THE THERMODYNAMIC PROPERTIES AND CONFIGURATION OF
UNSYMMETRICAL DIMETHYLHYDRAZINE ¹

-
1. This research was carried out on Contract N6-onr-269, Task Order III of O.N.R.
-

by J. G. Aston and J. L. Wood

The heat capacities of unsym dimethylhydrazine have been measured from 12°K to 298.16°K. The triple point ($215.951 \pm 0.005^\circ\text{K}$), the heat of fusion ($2407.4 \pm 1.5 \text{ cal. mole}^{-1}$), and the heat of vaporization at 298.16°K ($8366 \pm 4 \text{ cal. mole}^{-1}$) have been measured. The vapor pressure at 298.16°K is $159 \pm 1 \text{ mm}$. The entropy of the ideal gas at 298.16°K and 1 atm. was found to be $72.80 \pm 0.30 \text{ cal. deg}^{-1} \text{ mole}^{-1}$. Assuming the molecule to be entirely in the gauche form this corresponds to a barrier of $3000 \pm 1000 \text{ cal. mole}^{-1}$ hindering the internal rotation of the amino group. Using this same barrier an unlikely alternative allows 75 percent trans.

Rotation of the NH₂ group about the nitrogen-nitrogen bond in unsym-dimethylhydrazine would permit "trans" and "gauche" forms analogous to those possible in hydrazine ².

-
2. Penney and Sutherland, *Trans. Faraday Soc.*, **20**, 902 (1934); *J. Chem. Phys.*, **2**, 492 (1934)
-

This paper presents the results of a calorimetric investigation of unsym-dimethylhydrazine and a comparison of the third law entropy with that from spectroscopic and molecular data leading to a discussion of the probable barriers to internal rotation of the methyl and amino groups, and the configuration of the molecule.

Experimental

The Unsym-Dimethylhydrazine Sample. - The unsym-dimethylhydrazine was prepared by the method of Hatt ³, and purified by fractional distillation in a glass

3. Organic Syntheses, Coll. Vol. II, John Wiley and Sons, Inc., New York, N. Y., 1943, p.211.

helix packed forty plate column, maintained at a pressure of 680 mm using oxygen free nitrogen. From the change of the triple point with the fraction of sample melted (Table II), the solid-insoluble, liquid soluble impurity was determined as $0.01 \pm 0.01\%$. A part of this sample was used to determine the heat of combustion ⁴.

4. Aston, Rock, and Isserow, THIS JOURNAL, 74, 2484, 1952.

The Calorimeter. - A new platinum calorimeter and assembly, designed for adiabatic operation, was built. This will hereafter be designated calorimeter G. The assembly is similar in design to those previously reported from this laboratory ^{5a,b}.

5a. Aston and Szasz, THIS JOURNAL, 69, 3108 (1947)

5b. Morrison and Szasz, J. Chem. Phys., 16, 280 (1948)

Temperatures are measured with a strain-free platinum resistance thermometer Pt-G20, which meets all requirements of the International Temperature Scale of 1948 and this scale was used above 90°K. This thermometer has been calibrated against the thermodynamic scale of the National Bureau of Standards, and by comparison with a high precision helium thermometer in this laboratory ⁶.

6. Aston, Moessen, etc. To be published. All the data had not been computed at the time this paper was written.

The latter comparison was part of an investigation to provide a thermodynamic scale for this and other thermometers in the region 10°K - 90°K. The scale

below 90°K was based on a combination of the data. The energy input to the calorimeter was measured by the method described by Aston, et. al. ⁷.

7. Aston, Fink, Jans and Russell, THIS JOURNAL, 73, 1939 (1951)

This calorimeter was used in all measurements except those of the heats of vaporization which were taken in calorimeter F ⁷.

Heat Capacity Measurements. - The heat capacity of the empty calorimeter in the range 12°K - 300°K was measured immediately previously. The heat capacities of a sample of 63.33 g. (1.0491 mole) were measured over 54 temperature intervals from 12°K to 300°K. The rounded values are presented in Table I.

Table I

Heat Capacity of ungym-dimethylhydrazine at Integral Temperatures

mol. wt. 60-08;

0°C = 273.16°K;

1 cal = 4.1833 int. joules

T°K	\bar{C}_p cal./deg/mole	Temp. °K	\bar{C}_p cal./deg/mole
13	0.65	135	15.42
14	0.805	140	15.84
15	0.95	145	16.255
16	1.105	150	16.675
17	1.28	155	17.10
18	1.46	160	17.515
19	1.64	165	17.93
20	1.82	170	18.33
21	2.00	175	18.735
22	2.18	180	19.12
23	2.36	185	19.55
24	2.535	190	19.97
25	2.72	195	20.42
30	3.74	200	20.88
35	4.71	205	21.36
40	5.56	210*	21.87
45	6.345	215*	22.36
50	7.09	215.951	22.46 crystal
		Fusion	
55	7.76	215.951	36.25 liquid
60	8.32	220	36.43
65	8.91	225	36.65
		Fusion	
70	9.48	230	36.86
75	10.01	235	37.08
80	10.54	240	37.26
85	11.055	245	37.44
90	11.505	250	37.60
95	11.94	255	37.76
100	12.385	260	37.90
105	12.815	265	38.07
110	13.255	270	38.23
115	13.68	275	39.40
120	14.12	280	38.59
125	14.555	285	38.78
130	14.99	290	38.95
		295	39.11
		298.16	39.21

* From points corrected for prefusion.

The mean deviation of the experimental points from the best curve is 0.02 percent for the crystal and 0.01 percent for the liquid. Only the heat capacities 6° below the melting point were effected by pre-fusion. These have been corrected for the effect of 0.01 mole percent impurity. Correspondingly, the heats of fusion presented in Table III have been corrected for the small amount melted in the pre-fusion. The correction for vaporization into the filling line was only 0.1 percent at the highest temperature and therefore neglected. The heat capacity of the calorimeter, at various temperatures, was redetermined after the sample had been removed. It was within 0.1% of the original value. Of the sample, 0.09 g was not recovered from the calorimeter at the termination of the investigation. It is considered that this did not remain in the calorimeter as involatile material, but remained as vapor in the manometer and connections and absorbed in the stopcocks essential for measurement of vapor pressures. Inasmuch as the material was confined by a magnetic breaker during all measurements except the vapor pressure measurements which were the last made, this loss of material did not effect any of the thermal measurements.

The Melting Point. - Equilibrium temperatures of solid and liquid unsym-dimethylhydrazine were observed with increasing fractions of the sample melted. This data is presented in Table II along with the reciprocal of the fraction melted.

Table II

Triple Point Temperatures of ~~Unsym~~-Dimethylhydrazine

$$0^{\circ}\text{C} = 273.16^{\circ}\text{K}$$

Temp. $^{\circ}\text{K}$	$\frac{1}{\text{Fraction Melted}}$
213.863	23.14
215.934	3.86
215.940	2.11
215.945	1.45
215.947	1.04

Solid insoluble, liquid soluble impurity: 0.01 mole percent.

Calculated triple point for zero impurity: 215.951°K .

Table III

Heat of Fusion of unmelted-DimethylhydrazineMol. wt. 60.06; $0^{\circ}\text{C} = 273.16^{\circ}\text{K}$; 1 cal. = 4.1843 int. joules; melting point 215.97°K .

Temperature $^{\circ}\text{K}$	Interval	Heat input: cal./mole	$C_p \frac{dT}{dt}$ cal./mole	Heat of Fusion cal./mole	Pre-melting cal./mole	ΔH Fusion cal./mole
206.808	219.193	2891.50	482.97	2408.53	+0.02	2408.5
207.950	219.141	2847.20	440.77	2406.43	+0.10	2406.5
212.142	217.231	2668.25	262.32	2404.93	+1.17	2407.1
Mean $\Delta H =$						2407.4
						\pm
						1.50
213.490 ^a	221.182	2772.67		2411.14	3.45	2414.59

^a From melting point determination.

The Heat of Fusion. - Three independent determinations of the heat of fusion of unsym-dimethylhydrazine were made, and the resulting values are presented in Table III. The usual corrections for premelting, and for the heating of the solid and of the liquid have been applied⁵. For comparison, the value obtained by summing the heat input in determining the melting point, is appended. This value is not used in the evaluation of the mean heat of fusion to be used in the entropy.

The Vapor Pressures. - The vapor pressure of unsym-dimethylhydrazine at 298.16°K is required for the evaluation of the entropy of the ideal gas at this temperature. A series of measurements of the vapor pressure at various temperatures between the melting point and 298.16°K were made by the method previously used in this laboratory^{5a}.

The vapor pressure extrapolated to 298.16°K on the basis of these data is 158.50 ± 0.30 mm.

The Heat of Vaporization. - Four independent values of the heat of vaporization were obtained directly by vaporizing small fractions of the sample from the calorimeter into weighed bulbs cooled with liquid nitrogen. The method used, and the corrections applied, are as described for methylhydrazine⁷. The results are presented in Table IV. The values at 298.16°K were obtained using values of ΔC_p obtained from the heat capacity of the gas calculated from the spectroscopic data and barriers discussed later along with the observed liquid heat capacities.

The Entropy from Calorimetric Data. - The entropy of unsym-dimethylhydrazine calculated from the above calorimetric data is summarized in Table V. The correction for the vapor imperfection at 298.16°K was estimated to be 0.04

cal deg⁻¹ mole⁻¹ based on comparison with related compounds.

Discussion

The Entropy from Spectroscopic and Molecular Structure Data. 2. Considering rotation about the nitrogen-nitrogen bond, the possible forms of unsym-dimethylhydrazine are the "trans" form, corresponding to a sector of $2\pi/3$ and two "gauche" forms, each corresponding to a sector of $2\pi/3$. The entropy is calculated for both forms, assuming all angles tetrahedral, and the following bond distances and angles ⁸.

8. Beamer, THIS JOURNAL, 70, 2979 (1948)

N - N, 1.45 Å; C - N, 1.47 Å; C - H, 1.09 Å; N - H, 1.04 Å. LC-N-C = LC-N-N = 110°. The product of the principal moments of inertia for the trans form is 1.519×10^{-114} g. cm² and for the gauche forms 1.495×10^{-114} g. cm². The reduced moments of the methyl and amino groups were calculated by the method of Pitzer ⁹.

9. Pitzer, Journal of Chem. Phys., 14, 239 (1946)

For the "trans" form, the reduced moment of each of the methyl groups is 5.03×10^{-40} g. cm², and that of the amino group is 3.04×10^{-40} g. cm² while for the "gauche" forms that of the methyl groups is 5.02×10^{-40} g. cm² and that of the amino group 3.03×10^{-40} g. cm². The symmetry number for external rotation is 1 in both cases, three for the methyl group internal rotation, and one for that of the amino group, but $R \ln 3$ must be subtracted from the free rotational entropy to limit the amino group to a sector of $2\pi/3$.

The frequencies used in the calculation of the vibration entropy contribution were: 413, 443 (2), 803, 904, 961, 1044 (2), 1214,⁽²⁾ 1301 (2), 1457 (⁷), 2771 (2), 2818 (2), 2950, 2988, 3133, 3305 cm⁻¹ 10.

10. Aston, Shull and Wood, to be published.

The contributions to the entropy are presented in Table VI. Comparison with related compounds leads to the choice of a barrier of approximately 3,700 cal. mole⁻¹ hindering the rotation of the methyl groups ¹¹.

11. Aston, Faraday Society Discussions, 10, 76 (1951)

For the internal rotation of the amino group a barrier of 3,000 cal. mole⁻¹ was assumed.

If the potential functions be of cosine form for the methyl and amino groups these barriers give libration frequencies of 255 cm⁻¹ and 295 cm⁻¹ respectively. Examination of the Raman spectrum of the liquid shows a marked broad band around 285 cm⁻¹, with a spread of approximately 30 wave numbers in keeping with these assumptions. As has been pointed out by Penney and Sutherland ² and confirmed by comparison of third law entropies with those calculated from molecular data for hydrazine ¹², methylhydrazine ¹³ and sym-dimethylhydrazine ¹⁴

12. Scott, Oliver, Gross, Hubbard and Hoffman, THIS JOURNAL, 71, 2293 (1949)

13. Aston, Fink, Janz and Russell, THIS JOURNAL, 73, 1939 (1951)

14. Aston, Janz and Russell, THIS JOURNAL, 73, 1943 (1951)

the trans form has a higher energy than the gauche forms and exists in negligible quantities at room temperatures. Such would also be expected for unsymmetrical dimethylhydrazine.

Comparison of the experimental value with the entropy calculated for the gauche form alone shows excellent agreement for the barrier of 3000 cal. mole⁻¹. However, agreement with the experimental value can be obtained assuming a mixture of 75 percent of trans and 25 percent of an equimolar mixture of the d and l gauche forms.

If a barrier of 3700 cal. mole⁻¹ be chosen the entropy is decreased to 0.21 cal. deg⁻¹ mole⁻¹ below the experimental value. This is just with the

experimental error. The barrier found in hydrazine is 2800 cal. mole⁻¹ ¹². If the effect of substitution of methyl groups were as in trimethylamine the barrier for the amino group could be increased to as high as 3700 cal. mole⁻¹, a value not excluded by our data. It is of interest that the value of the amino group in methyl hydrazine ¹³ could possibly be as high as 3400 cal. mole⁻¹ which is the value to be expected by analogy with dimethyl amine.

Table IV

Heats of Vaporization of unsymmetrical Dimethylhydrazine

Mol. wt. 60.082; $0^{\circ}\text{C} = 273.16^{\circ}\text{K}$; 1 cal = 4.1833 int. joules

Moles Vaporized	Mean Temp. of Vaporization K.	H T, $^{\circ}\text{K}$.	H real gas 298.16 $^{\circ}\text{K}$., cal./mole
.052462	297.76	8376	8376
.052262	296.50	8412	8373
?	297.66	8385	8373
.076745	300.63	8292	3350
			Average 8366

Table V

Entropy of unsym-DimethylhydrazineMol. wt. $0^{\circ}\text{C} = 273.16^{\circ}\text{K}$; 1 cal. = 4.1833 int joules

	Cals.	cal. deg ⁻¹ mole ⁻¹
0 - 15 ^o K. Debye function		.24 ± .01
15 = six degrees of freedom		24.28 ± .05
215.951 ^o K.		
Fusion 2407.4/215.951		11.15 ± .01
215.951 - 298.16		12.19 ± .05
Entropy of Liquid at 298.16 ^o K		47.86 ± .12
Vaporization 8366/298.16 ^o K		28.06 ± .15
Entropy real gas at 298.16 ^o K, 158.5 mm		75.92 ± .27
Entropy ideal gas 298.16 ^o K, 158.5 mm		75.96 ± .29
Compression R ln 158.5/760		=3.11 ± .03
Entropy ideal gas at 298.16 ^o K and 760 mm		72.85 ± 0.32 e.u.

Table VI

Entropy of unsym-dimethylhydrazine from molecular data at 298.16°K

	<u>Trans Form</u>	<u>Gauche Form</u>
	cal. deg ⁻¹ mole ⁻¹	cal. deg ⁻¹ mole ⁻¹
S. translation	38.19	38.19
S. vibration	3.3 ⁹ 0	3.3 ⁹ 0
S. external rotation	23.96	24.18
S. mixing optical isomers (R ln 2)	0	1.38
S. int. rot. Me (V = 3700)	3.89	3.89
S. int. rot. NH ₂ (V = 3000)	1.76	1.78
Sum	<hr/> 71.1 ⁹ 0 <hr/>	<hr/> 72.8 ¹ 0 <hr/>
S. int. rot. (V = 3700)	1.54	1.54
Sum	<hr/> 70.9 ⁷ 0 <hr/>	<hr/> 72.5 ⁹ 0 <hr/>
Observed	72.85 ± .30	72.85 ± .3