

UNCLASSIFIED

AD _____

DEFENSE DOCUMENTATION CENTER

FOR

SCIENTIFIC AND TECHNICAL INFORMATION

CAMERON STATION ALEXANDRIA, VIRGINIA

DOWNGRADED AT 3 YEAR INTERVALS:
DECLASSIFIED AFTER 12 YEARS
DCD DIR 5200.10



UNCLASSIFIED

THIS REPORT HAS BEEN DECLASSIFIED
AND CLEARED FOR PUBLIC RELEASE.

DISTRIBUTION A
APPROVED FOR PUBLIC RELEASE;
DISTRIBUTION UNLIMITED.



ELECTROKINETIC TRANSDUCERS

Technical Report No. 2

AD-8015

PROPERTIES OF ELECTROKINETIC TRANSDUCERS
and
Factors Determining their Suitability
in Various Applications

Technical Report No. 2

Prepared for the Office of Naval Research under:

Contract Nonr-617(00)
Project NR 385 407

THE BETA CORPORATION
Post Office Box 8625
Richmond 26, Virginia

By:

E. V. Hardway, Jr.
E. V. Hardway, Jr.
President

December 1, 1952

TABLE OF CONTENTS

<u>Subject</u>	<u>Page</u>
1. Introduction	1
2. Principles of Operation	3
2.1 General	3
2.2 The Single Capillary Transducer	3
2.3 A Porous Plug Transducer	5
2.4 The Electrokinetic Cell	7
2.5 Summary	8
3. Properties of Electrokinetic Transducers	10
3.1 Certain Transducer Designs	10
3.2 Sensitivity, Output Impedance, and External Loads	11
3.3 Stability	15
3.4 Low Frequency Response	16
3.5 High Frequency Response	18
3.6 Pressure Range and Linearity	22
3.7 Resolution and Noise	23
3.8 Acceleration Sensitivity	24
3.9 Efficiency	25
3.10 Electro-Osmosis and Electrokinetic Generators	25
4. Factors Determining the Suitability of Electrokinetic Transducers for Various Applications	27
4.1 General	27
4.2 Pressure Range	28
4.3 Operating Temperature Range	29
4.4 Hydrophones	29
4.5 Differential Pressure Measurements	30
4.6 Underwater Blast and Other Very High Pressure Measurements	31
4.7 Linear Acceleration Measurements	33
4.8 Angular Acceleration Measurements	34
4.9 Velocity and Displacement Measurements	34
4.10 A Comparison with Piezoelectric Transducers	35
5. References	38
6. Definitions of Symbols	39

LIST OF FIGURES

No.	Description	Appears after Page No.
2-1	Single Capillary Transducer	3
2-2	Expanded View of Capillary	3
2-3	Porous Plug Transducer	6
2-4	An Electrokinetic Cell	6
2-5	Equivalent Circuits Midband Frequencies	7
2-6	Equivalent Electrical Circuit High Frequencies	7
3-1	Section - Type 3 Transducer	10
3-2	Section - Type 4 Transducer	10
3-3	Resistance and Sensitivity vs. Temperature	14
3-4	Resistance and Sensitivity vs. Temperature	14
3-5	Compensation with NTC Resistor	15
3-6	Low Impedance Load Compensation	15
3-7	Circuit Showing Electrode Elements	18
3-8	Equivalent Circuit at Low Frequencies	18
3-9	Type 4 - Air Frequency Response	20
3-10	Type 4 - Air Frequency Response	20
3-11	Type 4 - Frequency Response with 20 Ft. Cable	20
3-12	Type 4 - Underwater Response	20
3-13	Type 3 - Air Response	20
3-14	Type 4 - Underwater Response with Theoretical Curve	20
3-15	Equivalent Circuit Showing Mass Loading	20
3-16	Sensitivity vs Pressure, Data Taken by NOL	22
3-17	Sensitivity vs Sound Pressure	22
3-18	Streaming Potential vs Pressure-Water	22

No.	Description	Appears after Page No.
4-1	Differential Pressure Transducer	30
4-2	Explosion Pressure Transducer	31
4-3	Electrokinetic Accelerometer	33
4-4	Schematic, Velocity and Displacement Measurements	35
	Displacement Transducer	41

PROPERTIES OF ELECTROKINETIC TRANSDUCERS

1. INTRODUCTION

This report together with Technical Report No. 3 summarizes our current knowledge of the properties of electrokinetic transducers which employ porous plugs as transducing elements. The intention in this report is to present the more practical aspects of electrokinetic transducers in the light of current knowledge and to state what we now know or can readily foresee with regard to those factors which will govern future applications. Technical Report No. 3 will contain more general theoretical derivations and data tabulations which will be of interest to investigators of electrokinetic phenomena.

The report contains information that was obtained in work on Office of Naval Research Contract Nonr-617(00). Much of the practical information on transducer design and non-contaminating choices of materials was derived from work done privately, on Naval Ordnance Laboratory Contract N60921s-1461 and other fixed price sale contracts since the latter part of 1950. A more comprehensive summary of the properties of electrokinetic transducers can be presented in this way. Inasmuch as electrokinetic transducers are new and are not well known in the field of instrumentation, it is hoped that the presentation of this information will interest scientific personnel in the Navy and elsewhere, and bring suggestions for applications not previously considered.

Technical Report No. 3 covers work, almost all of which was done under Contract Nonr-617(00). This report gives detailed and complete information on the factors which govern electrokinetic energy conversion in accordance with the following outline:

Contents: Technical Report No. 3

1. Introduction
2. Historical Background
3. General Theory of Operation of Electrokinetic Transducers.
4. Electrokinetic Properties of Certain Liquids in Porous Solids
 - a. Test Methods
 - b. Data Tabulations
 - c. Discussion
5. Equivalent Circuits
6. Conclusions and Suggestions for Future Investigations.
7. APPENDIX: Symbols, Units, and Conversion Factors

In general, it may be stated that electrokinetic transducers have voltage sensitivities comparable to piezoelectric devices. Their essentially resistive output impedance makes it possible to measure from frequencies well below 1 cps to 20 KC or above without special high impedance amplifier input circuits. As a result, substantially lower thermal noise levels may be obtained. These factors, together with the fact that the midband sensitivity is independent of cable length, will undoubtedly have an important bearing on their future applications.

2. PRINCIPLES OF OPERATION OF ELECTROKINETIC TRANSDUCERS

2.1 General:

Electrokinetic transducers may be defined as devices which employ the Helmholtz double-layer at a solid liquid interface as a means of intraconverting mechanical and electrical energy.

In this report we are primarily concerned with those devices in which a liquid is forced under an unknown applied pressure through a microporous plug to produce a streaming potential which is in turn measured to determine the unknown pressure or otherwise is caused to perform any useful function.

The literature is extensive on electrokinetic phenomena but is very limited with regard to transducers of the type described (1, 2). For this reason a rather complete explanation will be given on the essential operating principles, but leaving the detailed theoretical derivations to be presented in Technical Report No. 3.

2.2 The Single Capillary Transducer:

The basic principles of operation may be simply illustrated by considering the case of a single capillary since a microporous plug is in effect a "bundle" of capillaries.

In Figure 2-1 a single glass capillary tube connects two vessels each containing electrodes and one being subjected to an applied pressure causing the liquid shown to be forced through the capillary. The liquid may, for example, be distilled water and the containing vessels and capillary be made of glass.

An expanded section of the capillary is shown in Figure 2-2. The polar water molecules become oriented at the solid-liquid interface and by virtue of this preferred orientation and possible forced dissociation at the interface cause a double-layer to develop. In this double layer the negative ions are adsorbed to the solid surface and an equal number of positive ions distribute themselves a short distance away in a diffuse layer. Although the inner ionic layer is diffuse, it may be considered to be at an electrostatic center of gravity, i.e. with all of the ions in the moveable layer located at a distance "d" from the surface. Actually this distance "d" is extremely small, on the order of a few molecular spacings.

When the liquid is caused to move through the capillary the ions in the moveable layer are carried with the liquid causing a transportation of charge. The resulting potential

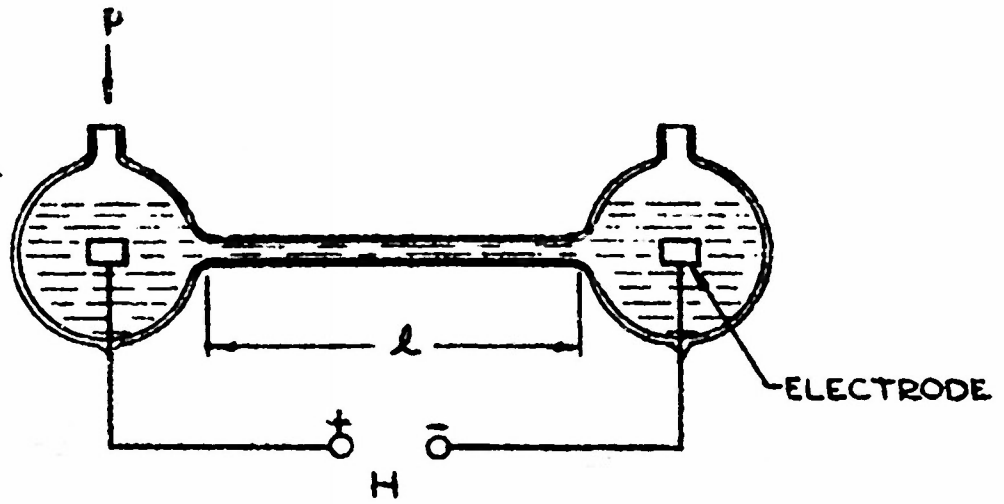

FIGURE 2-1

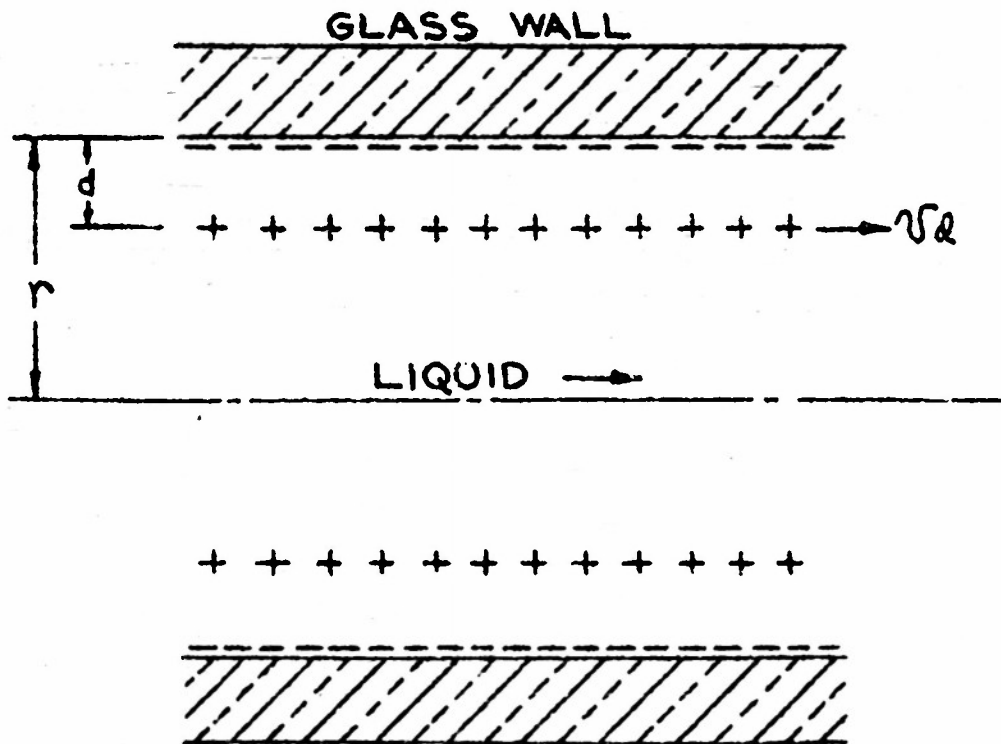

FIGURE 2-2

"H" developed between the two vessels and their electrodes causes a counter flow of ions in the bulk of the liquid and an equilibrium is simultaneously reached for non-turbulent flow in which the potential "H" is proportional to the pressure "p".

If the assumption is made that the radius "r" is much greater than "d", the double layer thickness, the following relations may be derived for a single capillary:

$$I = \frac{\sigma \rho}{r^2} V + \left[\frac{K_B \pi r^2}{l} + \frac{2\pi \sigma^2 (r)}{\eta l (d)} \right] H \quad (1.)$$

$$P = -\frac{\sigma \rho}{r^2} H + \frac{\sigma \eta l}{\pi r^4} V \quad (2.)$$

Where: I is the current flowing in the external circuit,
 V is the volume flow rate,
 P is the applied pressure,
 H is the electrode potential difference (neglecting polarization),
 σ is the electric moment of the double layer or charge per unit area times "d",
 d is the double layer thickness,
 η is the viscosity, and
 K_B is the bulk conductivity.

The first term on the right of Equation (1.) represents the flow of current in the double layer due to the volume flow, the second term the conductance current due to the bulk conductivity, and the last term the surface conductance of the double layer. Although the latter term is incomplete, it applies under certain conditions and is sufficient for purposes of explanation. The first term on the right of Equation (2.) is the osmotic pressure due to the voltage "H" and the second term in the ordinary relation for viscous flow in a round pipe or capillary.

It can be shown that a very close approximation can be made in practice by neglecting certain terms. For the streaming potential relationship the equations may be reduced for the purpose of this report to:

$$I = \frac{\sigma \rho}{r^2} V + \frac{K_B \pi r^2}{l} H \quad (3.)$$

$$P = \frac{\sigma \eta l}{\pi r^4} V \quad (4.)$$

Now when $I = 0$ i.e., when the transducer is operated in an open circuit condition, Equations (3.) and (4.) reduce to

$$\frac{H}{P} = - \frac{\sigma}{\eta K_B} \quad (5.)$$

In the previous equation K_c is the equivalent conductivity of the liquid in the capillary and may be considered equal to K_0 when the effects of surface conductance are negligible, i.e., for large capillaries.

From the theory given thus far several interesting conclusions can be drawn.

a. The sensitivity is independent of the length of the capillary, and would for "large" capillaries be independent of the radius. It is also evident that it would be independent of the number of parallel connected capillaries.

b. For a given transducer output resistance, the sensitivity can be increased by lowering the viscosity or increasing the electric moment.

c. If the electric moment is substantially independent of temperature and if Walden's Rule were applicable in maintaining the viscosity-conductivity product constant, the sensitivity would be independent of temperature. (This is true to better than 1% from minus 20°C to plus 65°C in certain instances).

2.3 A Porous Plug Transducer

The previous discussion of the single capillary will assist in understanding the important variables which affect the characteristics of porous plug transducers.

We first make the simplifying assumption that a microporous plug is a parallel bundle of capillaries with the same voltage to pressure relationship as exists in a single capillary but with N times the conductance where N is the number of capillaries. We then recognize two facts.

a. The factors controlling the magnitude of the electric moment are not fully understood and are not now subject to calculation. No theories as to its exact origin yet developed have been experimentally verified. Even certain "rules-of-thumb" which work reasonable well, have outstanding exceptions.

b. The same applies to a great extent to conductivity in the pores and "surface conductance."

As we are particularly concerned with microporous plugs with pore radii on the order of 1 micron or less where the sensitivity is a function of pore radii and are dealing not with round straight capillaries but with randomly shaped tortuous passages in the solid, we resort to parameters which can be experimentally determined and are used in equations

which satisfy the energy requirements of a passive system. In the equations so developed, no assumptions need be made with regard to the shape of the capillaries:

$$I = \frac{S_{(IP)H}}{q_v} V + G_o H \quad (6.)$$

$$P = - \frac{S_{(IP)H}}{q_v} H + \frac{V}{q_v} \quad (7.)$$

In the above equations $S_{(IP)H}$ is the short circuit current to volume rate sensitivity with $H=0$, G_o is the plug overall conductance and q_v is the flow conductance of plug for the given liquid, or the volume rate per unit pressure.

For the open circuit streaming potential case (6.) and (7.) may be reduced to:

$$\frac{H}{P} = - \frac{S_{(IP)H}}{G_o} \quad (8.)$$

To understand the factors that will control the sensitivity of the transducer as shown in Figure 2-3, it is necessary to break $S_{(IP)H}$ and G_o into their component parameters.

We first define K_o as the overall conductivity of the specific porous plug filled with a particular liquid. We make no assumptions but merely define:

$$K_o \triangleq G_o \frac{t}{A} \quad (9.)$$

where G_o is a measured quantity.

Omitting the derivation, we also write and define:

$$\alpha_{(ip)h} = S_{(IP)H} \frac{t}{A} = \frac{\beta F}{\eta} \quad (10.)$$

In equations (9.) and (10.) K_o and $\alpha_{(ip)h}$ are both properties of a particular liquid solid combination and may be determined from measurements of G_o and H/P since:

$$\frac{H}{P} = - \frac{\alpha_{(ip)h}}{K_o} \quad (11.)$$

The parameter "F" is the effective porosity defined by the equation in combination with the electric moment β .

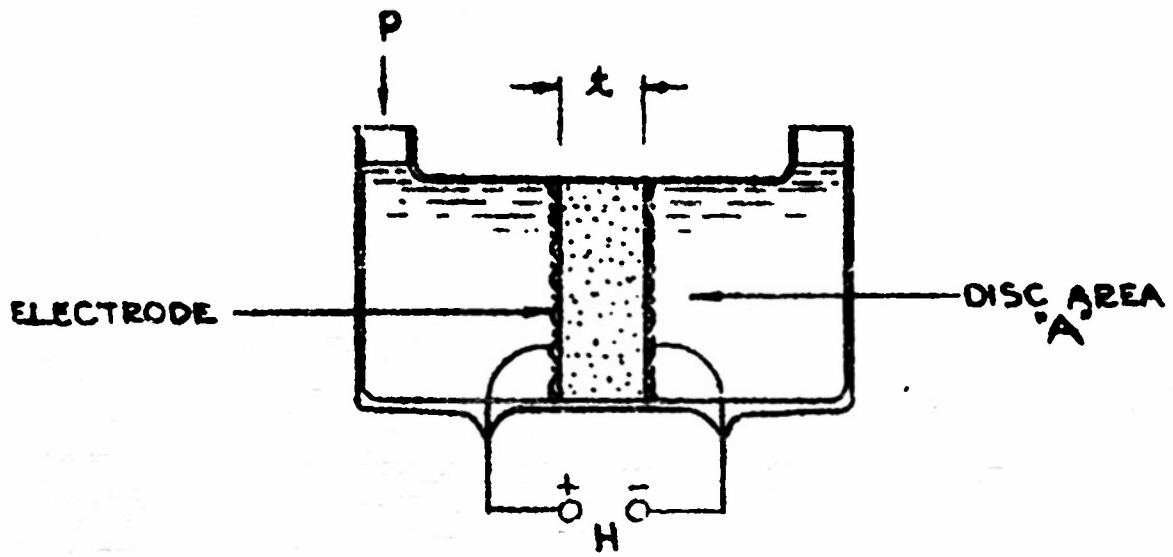

FIGURE 2-3

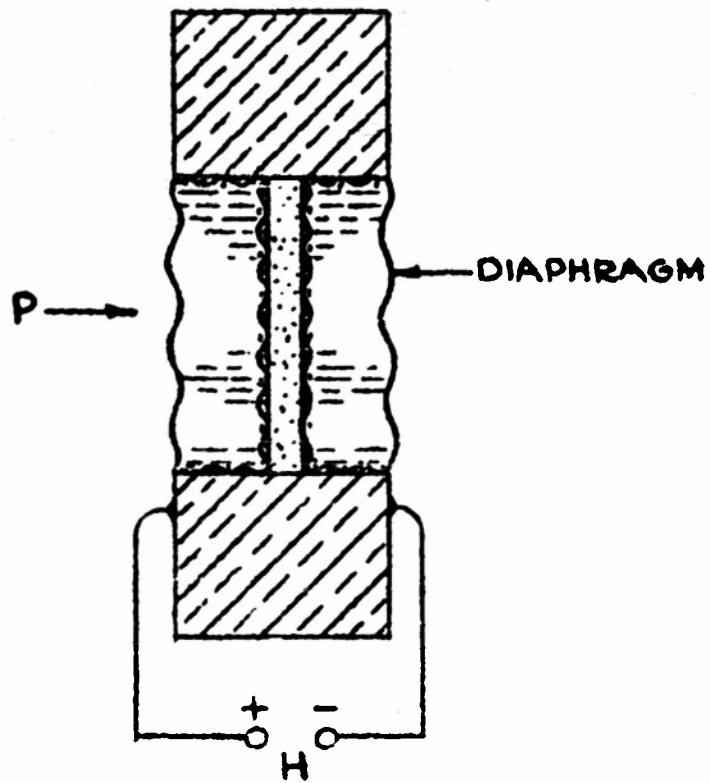

FIGURE 2-4
AN ELECTROKINETIC CELL

It is a property of the solid material.

If Equation (11.) is rewritten as:

$$\frac{H}{P} = - \frac{GF}{\eta K_0} \quad (12.)$$

and compared with Equation (5.), the similarity may be established. If the plug were a parallel bundle of similar capillaries and the effects of surface conductance were not present, it is evident that K_0 , the overall conductivity would be simply equal to $K_0 F$ and the two equations would be similar. To a certain extent this assumption would be reasonable for coarse materials. For microporous plugs, however, we are restricted to Equation (12.) in which K_0 is a measured quantity. G is unique to the particular solid-liquid combination which always appears in combination with F a property of the porous solid. The product can be experimentally determined for a given combination.

In this report we are principally concerned with H/P and R_0 (or $1/G_0$), the sensitivity and output resistance. The above factors are, however, important, at least in a qualitative sense in understanding what might be expected to occur when changes are made or occur in area, thickness, porosity, viscosity, etc.,

2.4 The Electrokinetic Cell.

In practice an electrokinetic transducer for use as an instrument must be sealed to prevent evaporation of the liquid. Inasmuch as certain contaminants will be present to be adsorbed or go into solution until a state of equilibrium is reached, it is also desirable to enclose a fixed quantity of liquid. Such an arrangement has been developed in the configuration shown in Figure 2-4. Here a porous disc is glazed into an impermeable solid insulating ring forming two chambers, each containing wire mesh electrodes in intimate contact with the surfaces of the disc. Each chamber is sealed with a diaphragm and filled with a suitable electrokinetically active liquid.

When a pressure P acts on one diaphragm, liquid is forced through the porous disc causing a streaming potential to develop across the two electrodes, which is proportional to the applied pressure. The output impedance is essentially resistive and hence the equivalent circuit is simply a voltage source "H" in series with a resistance R_0 as shown in Figure 2-5 at mid-band frequencies.

For microporous plugs of very small pore sizes the viscous flow conductivity is extremely small and for reasonably elastic diaphragms the travel is so small when

EQUIVALENT CIRCUIT FOR MID-BAND
FREQUENCIES

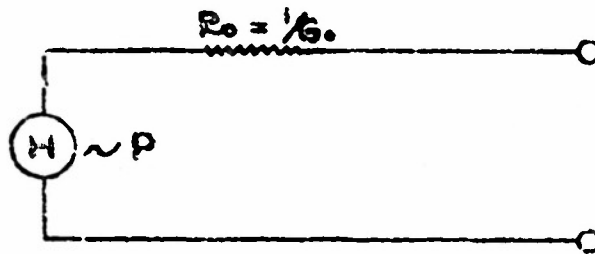

FIGURE 2-5

EQUIVALENT CIRCUIT AT HIGH
FREQUENCIES

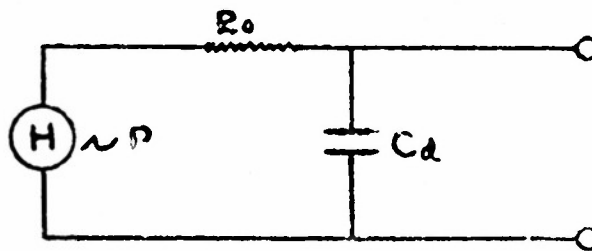

FIGURE 2-6

subjected to alternating or transient pressures that the diaphragms have negligible effect except at very low frequencies or during prolonged transients. In practice, experimental units have been made with frequency response extending to .02 cps. This low frequency response can be extended indefinitely by design but can never extend to zero in a closed transducer. In contrast to piezoelectric devices no comparable output impedance problems are encountered in the low ranges. Reasonably high impedance loads are required, however, to minimize polarization effects at low frequencies.

At high frequencies the equivalent circuit shown in Figure 2-6 is theoretically applicable. Here the transducing disc element is assumed to be inelastic and the phenomena itself independent of frequency. The internal capacity of the unit would be expected to cause an attenuation of 6db per octave beyond the break point at

$$\eta = \frac{1}{2\pi R_0 C_d}$$

Another factor which might be expected to enter the picture at high frequencies is the mass time constant defined as:

$$T_m = \frac{m g_v}{A^2 D}$$

where m is the mass of the liquid.

In practice, however, the upper frequency response in various designs thus far, has been limited by elastance effects in the disc, its supporting ring, and mounting means, causing the T_m time constant to play a relatively minor role. Units which drop in response rapidly in sensitivity in water at 30 KC should have a range extending to 50 KC from calculated attenuations based on RC or 500 KC based on T_m .

Although more complete theoretical derivations have been omitted for Technical Report No. 3, certain conclusions can be summarized from the theory of operation as presented thus far.

2.5 Summary:

a. The sensitivity of an electrokinetic transducer is proportional to the electric moment of the double layer, the porosity factor "F", and is inversely proportional to the overall conductivity of the liquid filled plug and the viscosity of the liquid.

b. Inasmuch as "F" is a constant essentially independent of temperature, if combinations are selected wherein the electric moment and the sensitivity are independent of temperature, the output resistance can be expected to vary directly with the viscosity of the liquid.

c. The Reynold's Number for the microporous plug pores for all liquids can be made extremely small. Linearity in performance may be expected over extremely wide ranges of pressure.

d. Inasmuch as the viscous forces may be made much greater than elastance forces except at very low frequencies and much greater than inertial forces except at very high frequencies, there is no need to compromise between range and sensitivity, or frequency response and sensitivity. The response in practice is not second order, hence the terms "natural frequency" and "damping ratio" would not carry the same direct connotations as they would for many other types of instruments.

e. The low frequency limit of operation is not established by the streaming potential phenomena itself but by mechanical design considerations. In a simple type of enclosed transducer, the low frequency range may be extended indefinitely but can never reach zero because of the finite diaphragm travel limits.

3. PROPERTIES OF ELECTROKINETIC TRANSDUCERS

3.1 Certain Transducer Designs:

Inasmuch as certain important data have been taken on "Type 3" transducers by the Naval Ordnance Laboratory and this Corporation which will be later presented, their construction will be described.

In this unit an inert porous disc or plug is clamped against an inner shoulder in a Teflon outer ring to form two chambers as shown in Figure 3-1. Electrodes of fine wire mesh cover both faces of the plug or disc, being held in place in front by an inner metal ring and in the rear by a metal backing plug to provide rigid support for the disc and maintain sealing pressure against the shoulder. Support from the rear is provided by the backing contact, and the backing plate which, in turn, act through the diaphragm to support the backing plug. Holes in the backing plug allow for flow of the electrokinetic liquid.

The outer clamp ring, and Teflon pressure ring in combination with the front and rear pressure gaskets locate the cell and provide sealing pressure of the metal diaphragms against the tapered faces of the outer ring.

The construction, as shown, was chosen to provide a nearly flush diaphragm for baffle blast pressure measurements and to provide rigid support for the porous plug (while providing for thermal expansion) to enable it to withstand high blast pressures.

In operation a pressure acting on the front diaphragm forces a minute amount of liquid through the porous plug pores causing a streaming potential to develop across the electrodes, the potential is conducted through the backing plug, rear diaphragm, etc., to the center conductor of the shielded cable which becomes positive for a positive pressure. The front electrode, inner ring and diaphragm are connected through a foil to the case and cable shield.

The "Type 4" transducer basic configuration originally designed as a baffle mounted blast gage (although not restricted to that application) was used in the form shown in Figure 3-2 for taking much of the data presented in this report and in Technical Report No. 3. Many modifications were made for different tests, but most of the essential components were as shown. The scale in Figure 3-2 has been distorted for clarity.

In this construction the electrokinetic cell consists of a porous disc glazed into a glass or porcelain ring. Wire mesh electrodes against the disc faces contact the metal diaphragms one of which is grounded and the other is connected as shown to the shielded cable. An elastomer

TYPE 3 TRANSDUCER

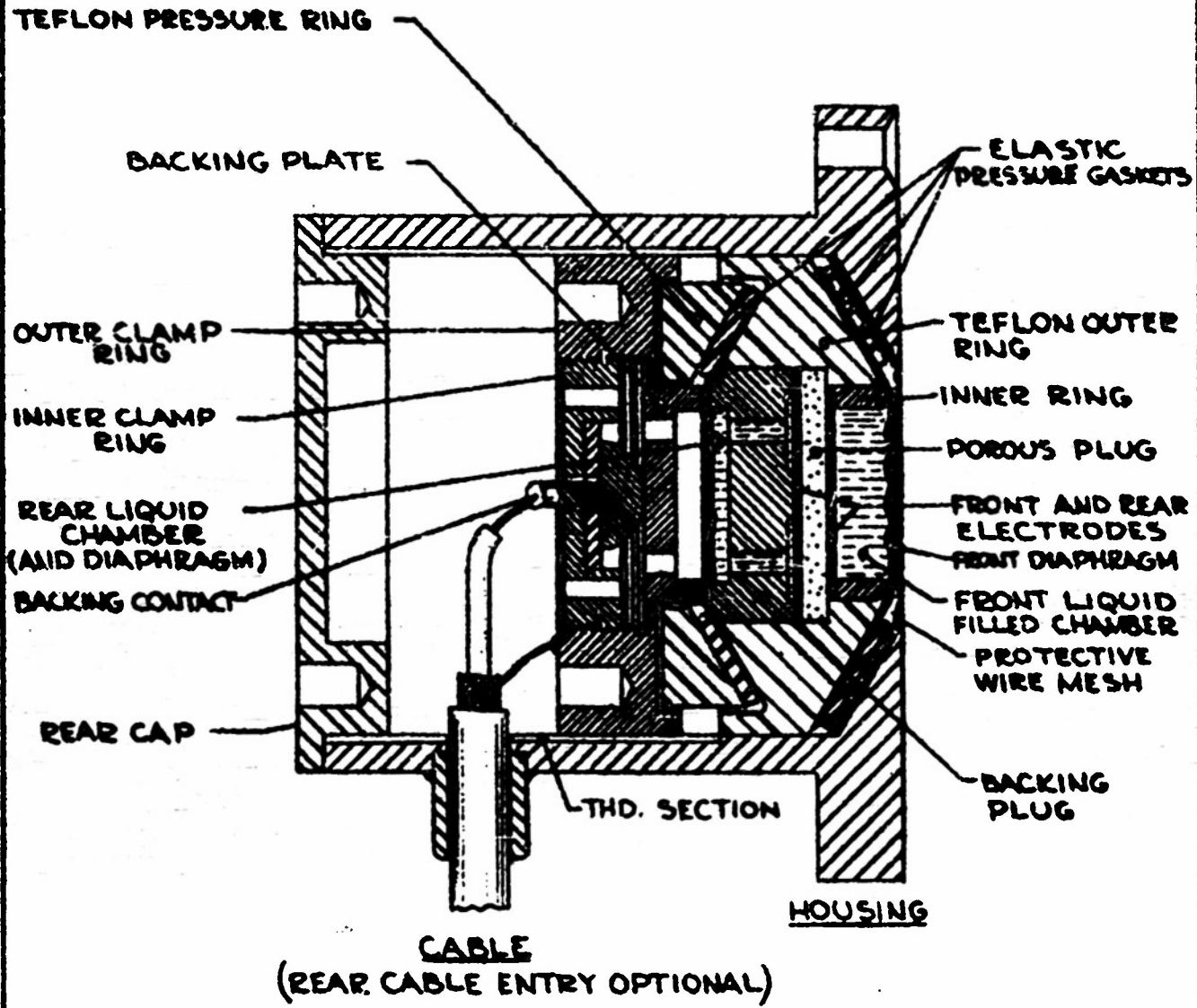

FIGURE 3-1

TYPE 4 TRANSDUCER

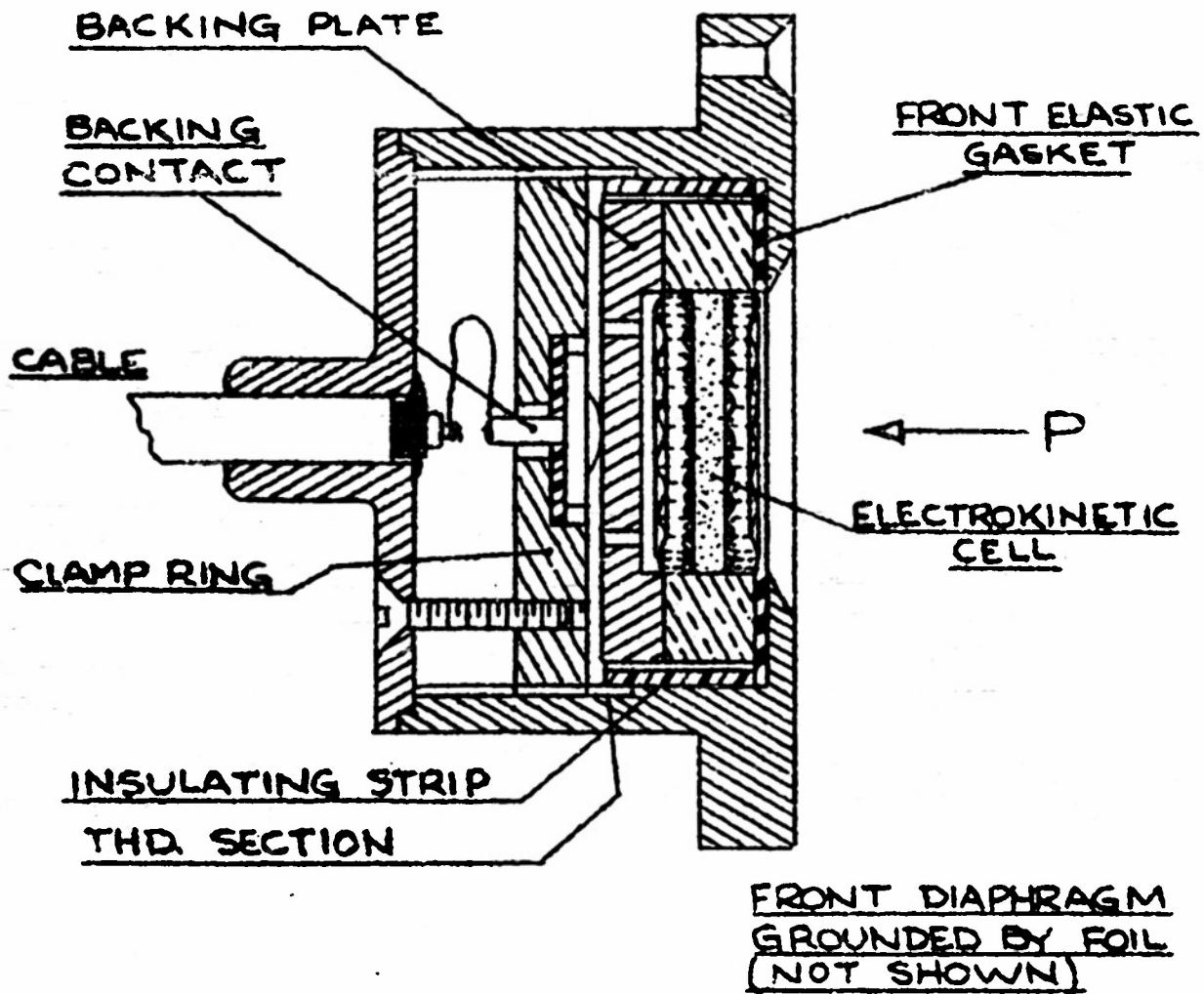

FIGURE 3-2

in front maintains sealing pressure while the backing plate, clamp ring, and backing contact provide rigid clamping to the case. The elastomer may be placed on either side of the cell unit. The operation of the cell is essentially the same as previously described in Section 2.3.

3.2 Sensitivity Output Impedance, and External Loads:

One of the most important advantages of electrokinetic transducers is their high sensitivity, in combination with the fact that they are self-generating, a single instrument being equally suitable for measuring pressures in a range of a few dynes per square centimeter or less to 100 psi or more. It may be said that they are to the best of our knowledge considerably more sensitive than any other type of transducers designed to operate over either the same range of frequencies, or the same range of pressures.

Equation (12.) is repeated below:

$$\frac{H}{P} = - \frac{\beta F}{\eta K_0}$$

From this equation it is evident that it is desirable in order to obtain a high sensitivity to employ a liquid with a low viscosity and which will produce a large electric moment in contact with the solid. It is also desirable to employ liquids which are as free as possible from ionizing contaminants, or which have low conductivities.

Some liquids will have a positive moment with respect to one solid, a negative moment with respect to another, and a negligible moment with respect to a third. The solid as well as the liquid plays an important part in determining the magnitude of the electric moment. Because of the physical requirements imposed on the solid, the necessity for the material to be inert and non-conducting, and the problem of availability, only a limited number of materials have been tested. Data published in the literature indicates, however, that an extended search to find more suitable solid materials than Pyrex glass or porcelain may not have been worthwhile.

The selection of liquids with "optimum" properties was a long task as the object was to find liquids which produced a large electric moment for a given conductivity and satisfy other requirements as to activity, boiling and freezing, viscosity, toxicity, etc.. A rule-of-thumb method was employed to eliminate a great number of liquids from consideration of molecular surface packing i.e., $(\rho/MW)^{1/3}$, dielectric constant, dipole moment, and viscosity.

Starting with all known liquid compounds on which tabulated information could be obtained, it became evident that the best choices were among the lighter alcohols, ketones, nitro-compounds, and saturated nitriles. The majority of the work done in the past has been done with water or water with the addition of various salts. Water, however, has been found very impractical to work with from several points of view and inferior in its electrokinetic properties. Acetonitrile had been previously chosen for blast gages manufactured for the Naval Ordnance Laboratory and has ultimately, after many tests, proved to be the most satisfactory compound for general usage.. Most of the data presented, therefore, relates to the use of acetonitrile with microporous porcelain, or Pyrex glass.

As an illustration of sensitivities involved with certain liquids and solids the following Tables I and II are given:

TABLE I

(.090" x .750" Dia. #03 Porcelain Disc)

Liquid	$K_B \times 10^6$	$R_o \times 10^{-3}$	H/PR _o	H/P	H/P(DB)
Acetonitrile	2.4	54.5	4.56	258	-108.6
Acetone	.86	200	3.2	640	-100.6
Methanol	3.6	240	1.19	286	-107.6
Nitromethane	6.75	94	1.01	95.2	-117.2
Diethyl Ketone	.24	1790	0.8	1430	-93.6
M. E. Ketone	.56	800	0.42	340	-106.2
Water	***	37	0.4	27.2	-128.2
n-Propyl Formate	.093	2280	0.215	490	-103.0

The above data was taken in a streaming potential test cell at 20°C. The flow permeability of the #03 porcelain material is approximately 5.6×10^{-11} cm².

TABLE II

(.082" x .750" Dia. Med. Pyrex Fritted Glass Disc.)

Liquid	$K_B \times 10^5$	$R_o \times 10^{-3}$	H/PR _o	H/P	H/P(DB)
Acetonitrile	1.48	350	3.83	1,340	-94.2
Water	5.25	126	2.16	272	-108.2
Acetone	.364	1,040	2.04	2,120	-90.2
Diethyl Ketone	.473	1,750	1.13	1,970	-91.2
Methanol	2.70	327	1.0	329	-106.4
M. E. Ketone	.875	915	0.539	493	-102.9
Nitromethane	7.75	144	0.392	56	-121.8
n-Propyl Formate	.25	3,290	0.182	600	-101.2

The above data was taken in a streaming potential test cell at 20°C. The flow permeability of the medium Pyrex disc material was $46.7 \times 10^{-11} \text{ cm}^2$.

In the above table K_B is the bulk liquid conductivity in reciprocal ohm centimeters, R_o is in ohms $\times 10^{-3}$, H/PR_o in microamperes per psi and H/P is in millivolts per psi. H/P(DB) is referred to 1 volt per dyne per square centimeter.

Inasmuch as the sensitivity is dependent on the purity of the liquid, it is not the best index of electrokinetic activity. In transducers it is desirable to have a maximum sensitivity and a minimum impedance. We, therefore, take the ratio below in "rating" various liquids.

$$\frac{H}{PR_o} = S_{(IP)}H \quad (\text{From Equation 8}) \quad (13.)$$

This gives an indication of the internal rate of flow of charge in the double layer - or the current sensitivity with a low impedance load.

When an instrument is utilized with a short cable to a very high impedance load such as a cathode follower, the sensitivity H/P in the table may be used to determine a good choice for the liquid.

The two tables indicate that acetonitrile has the highest current sensitivity with both solid materials. In the case of the glass disc the permeability is ten times greater than the porcelain and yet the voltage sensitivities are not proportionally greater.

Note that approximate resistance for any disc of similar material can be obtained from:

$$R_x = R_o \frac{t_x}{t_o} \left(\frac{D_o}{D_x} \right)^2 \quad (14.)$$

where x refers to an arbitrary diameter or thickness and "o" refers to the value in the table. Sensitivity is independent of area or thickness.

Values obtained in a sealed and stabilized transducer may generally be expected to differ depending on the surface history of the disc material, but such differences are not as significant as the degree of purity of the liquid and cleanliness of the parts exposed to the liquid.

The effects of temperature are of great importance in any transducer used in instrumentation work. We have found that in several combinations the electric moment \mathcal{S} is substantially independent of temperature. We have also found that stabilized porcelain disc transducers with purified acetonitrile are not affected by temperature as far as sensitivity is concerned. The internal impedance varies in accordance with the known change in viscosity as a function of temperature.

Data is presented on a Type 4, Ser. No. 9 transducer and on a Type 3, Ser. No. 21 transducer showing the sensitivity and impedance versus temperature in Figures 3-3 and 3-4. The constancy of sensitivity is a very beneficial property and will be most important factor in regard to future applications. If the streaming equation is written in the form most frequently found in the literature, i.e.,:

$$\frac{H}{P} = - \frac{fE}{4\pi\eta K_s}$$

and it is considered that all four parameters on the right including the zeta potential f and the dielectric constant ϵ are all strongly affected by temperature, it was not obvious that combinations could be found in which the temperature variation of H/P would be negligible over a wide range of temperature.

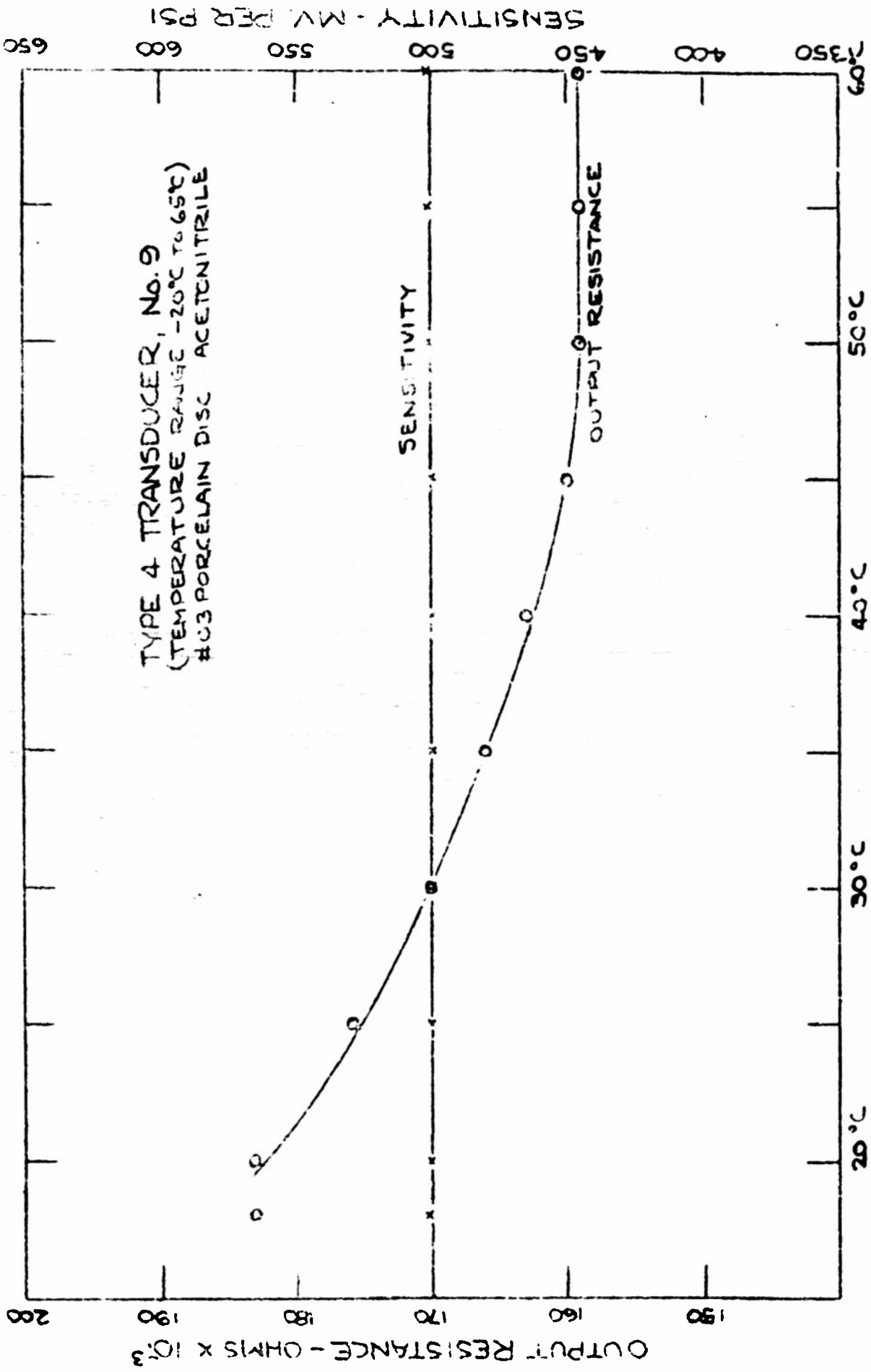

OUTPUT RESISTANCE AND SENSITIVITY VERSUS TEMPERATURE
 FIGURE 3-3

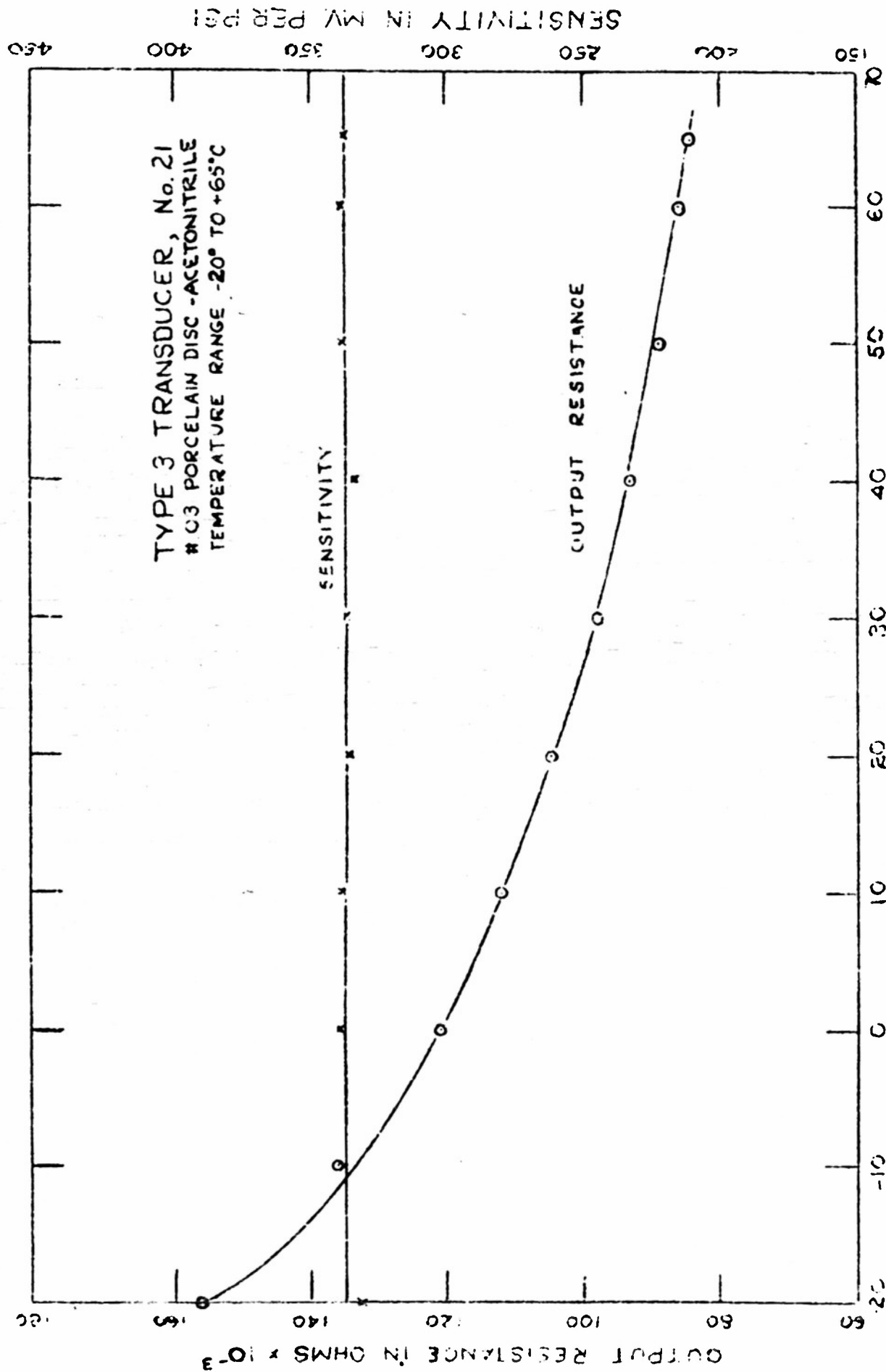

OUTPUT RESISTANCE AND SENSITIVITY VERSUS TEMPERATURE
 TEMPERATURE °C
 FIGURE 3-4

In Figure 3-5 an arrangement is shown for compensating a transducer whose sensitivity does increase with temperature by means of a negative temperature coefficient resistor. Such an arrangement would be necessary when acetonitrile is used with a Pyrex disc and in a number of other material combinations.

The power output of an electrokinetic transducer, particularly in larger sizes would be ample for driving a low impedance microammeter or galvanometer. It should be noted, however, that unless a cathode follower is used, compensation has to be made for low impedance loads because of the change of resistance with temperature. Such an arrangement is shown in Figure 3-6.

The high frequency effects of cable capacity can be readily computed by the equation:

$$\left(\frac{H}{P}\right)_{\omega} = \left(\frac{H}{P}\right) \frac{1}{\sqrt{1 + (\omega R_0 C)^2}} \quad (15.)$$

For frequencies up to 30 KC and cable lengths up to ten feet this has not been found to be a limitation.

The effects of polarization and electrode impedance at low frequencies is discussed in Section 3.4.

3.3 Stability:

Originally one of the most difficult problems to overcome in designing transducers for investigating electrokinetic phenomena or for pressure measurements was that of stability. It was found, however, that with proper choices of inert material combinations, for the liquid, electrodes, diaphragms and sealing compounds that such transducers when sealed and heated over a period of several days would approach a constant stable sensitivity. (The initial decay is exponential in character.) After the stabilization period the sensitivity remains constant. (Although Type 4 blast gages for example, have only been in use for about six months we have had no reports to the effect that changes in sensitivity have occurred. Very complete tests have been run by laboratories to whom such units have been delivered and after time lapses of several months.)

In taking data on the electrokinetic properties of different porous solid - liquid combinations in our investigations of electrokinetic phenomena we used somewhat different experimental techniques from those used in the past. We closed off the liquid solid combination in a sealed system and made most of our tests at alternating pressures while varying the temperature. This approach was used for the following reasons:

TRANSDUCER

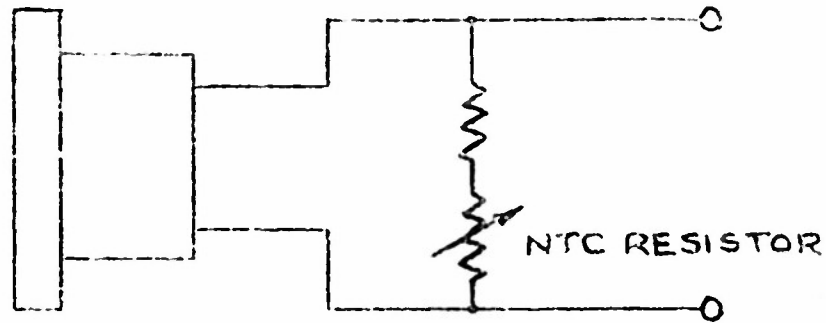

TEMPERATURE COMPENSATION WITH
AN NTC RESISTOR

FIGURE 3-5

TRANSDUCER

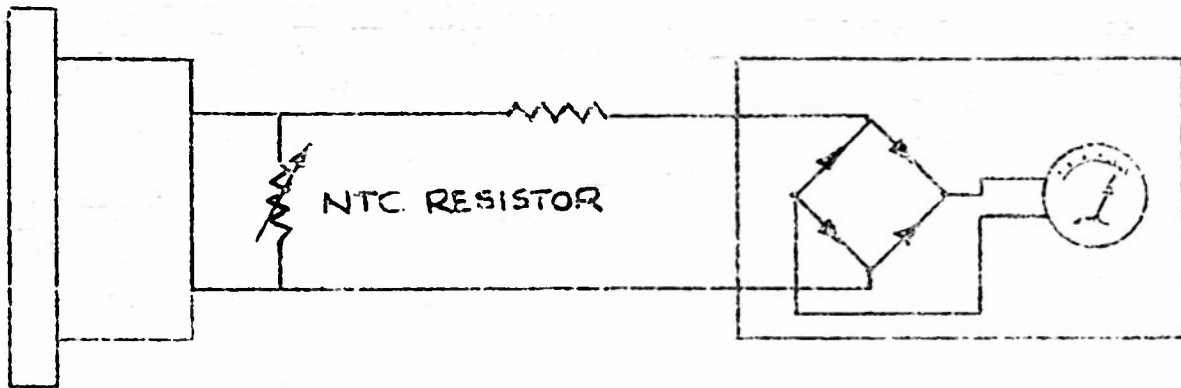

COMPENSATION FOR VARIATION OF OUTPUT
RESISTANCE WITH LOW IMPEDANCE LOAD

FIGURE 3-6

a. It was desirable to insure, insofar as possible, that a state of equilibrium had been reached with regard to the conductivity of the liquid and the time varying factors affecting the magnitude of the electric moment. Effects produced by the past history of the solid surface were thus minimized. The test transducers were heated and subjected to alternating pressures for several days, in most cases, before data were taken. The advantages of this method were verified by the fact that in many cases preliminary test results on the first day were erratic - so that incorrect conclusions may have been drawn if we had used a apparatus in which the fresh liquid was steadily streamed under a constant pressure.

b. Polarization effects were negligible and it was considerably simpler to obtain accurate results and measure small differences using an A.C. vacuum tube voltmeter.

The single disadvantage of the method of testing was that the bulk conductivity of the liquid after stability had been achieved was unknown. It was felt, however, that this disadvantage was outweighed by the many other advantages.

It was found in general that no available elastomers, and very few sealing compounds or plastics could be used in contact with the liquid of the electrokinetic cell. In spite of the advantages of using materials such as Teflon for diaphragms in obtaining good low frequency response with a relatively rugged diaphragm material, no plastics can be used alone for diaphragms. This is because of the diffusion permeability of all known plastics to air and the liquid vapors. Only thin metal diaphragms or foil-plastic laminated diaphragms have thus far been found suitable.

In each new design the stability problem will resolve itself in terms of effecting absolute seals between the inside and outside of the electrokinetic cell. If the inside materials are inert to the pure liquid used, the liquid is degassed to remove oxygen and prevent bubble formation, and a good seal is made, there are no reasons to expect a change of sensitivity with time after the initial stabilization period.

3.4 Low Frequency Response:

As previously stated, the low frequency response of the type of transducer illustrated in Fig. 3-2 for example, may be extended indefinitely by design but cannot extend to zero. Experimental units have been made in which the low frequency break point (3DB down) is .02 cps. There is no limitation on the phenomena taking place in the porous plug. The limitation is rather a result of the stiffness and travel limitation of the diaphragms and the flow conductance of the porous plug.

The flow conductance of the plug or disc is given by:

$$g_v = \frac{B}{\eta} \left(\frac{A}{t} \right) \quad (16.)$$

where B is the permeability of the solid in centimeters squared, η is the liquid viscosity in poise and A and t are in the area and thickness. The dimensions of g_v are centimeters⁵ per dyne second. The grade #03 porcelain we often use, has a permeability of $5.6 \times 10^{-11} \text{ cm}^2$. (Materials are available with permeability considerably higher and lower than this figure.)

If k_D is the effective pressure stiffness of the diaphragms in dynes per centimeter² per centimeter (displacement), then the low frequency time constant is given by:

$$T_L = \frac{A}{g_v k_D} \quad (17.)$$

and the low frequency response is given by:

$$\left(\frac{H}{P} \right)_L = \left(\frac{H}{P} \right) \frac{1}{\sqrt{1 + (1/2\pi\eta T_L)^2}} \quad (18.)$$

The response will drop 3DB or 29.3% at the frequency:

$$\eta_L = \frac{1}{2\pi T_L} \quad (19.)$$

There are numerous methods of extending the low frequency response. Some of these are tabulated along with their relative disadvantages below:

- Decrease plug permeability Lowers sensitivity
- Decrease plug area or increase thickness Raises impedance
- Use thinner diaphragm material Decrease strength
- Use larger diaphragm diameter Increases size

It will be evident that the method chosen will in each case, depend on the application where in many cases the corresponding disadvantage will not be important.

As an example, for one transducer:

- Diaphragms 3/4", .005 Polyethylene-Aluminum
- Liquid Acetonitrile at 20°C.
- Disc75D by .080, #03 porcelain
- N_L 0.16 c.p.s.

When current is drawn in an external circuit and the cell resistance is in a low range, polarization effects reduce the useful lower limit. The equivalent circuit then becomes as indicated in Figure 3-7.

In this circuit typical effective values obtained in bridge measurements on a transducer, were $R_v = 45K$, $R_e = 20K$ and $C_e = 0.3$ mfd. These values are, of course, a function of bridge current, but are given to indicate how erroneous results can be obtained by assuming a pure resistance in bridge measurements and why at very low frequencies, it may be necessary to operate electrokinetic transducers into high impedance input circuits. For a given current the electrode impedance is reduced as the area is increased. The valves given are for 20 mesh .010 aluminum wire cloth.

Figure 3-8 is a complete equivalent circuit showing the elements which affect the low frequency response. Typical values are given below:

$$\begin{aligned}
 R_v &= 29 \text{ megohms} \\
 C_{dia} &= .017 \text{ mfd,} \\
 G_o &= 16.7 \times 10^{-6} \text{ mhos} \\
 R_e &= 20K \\
 C_e &= 0.3 \text{ mfd} \\
 \eta_L &= 0.28 \text{ cps} \\
 M &= 40.7 \text{ ampere sec./meter}^2
 \end{aligned}$$

In the equivalent circuit, M is the electromechanical coupling constant and is defined by:

$$M = \frac{S(\rho)H}{g_v} \quad (20.)$$

This ratio appears in the basic Equations (6.) and (7.)

To summarize, two considerations are involved in extending low frequency response; increasing the time constant T_L , and, if current is drawn, maximizing the effective electrode area to minimize polarization impedance effects. Neither of these offer serious obstacles in any designs thus far considered.

3.5 High Frequency Response:

The following general statements regarding high frequency response are based on data taken on electrokinetic transducers of the general type of construction shown in Fig. 3-2, and employing .750"D x .080" discs.

The useful range with selected cable and load capacities extends to 20KC and based on somewhat less accurate measurements to 30KC or above in air. Accuracy within 2db can be achieved with respect to diaphragm pressure response.

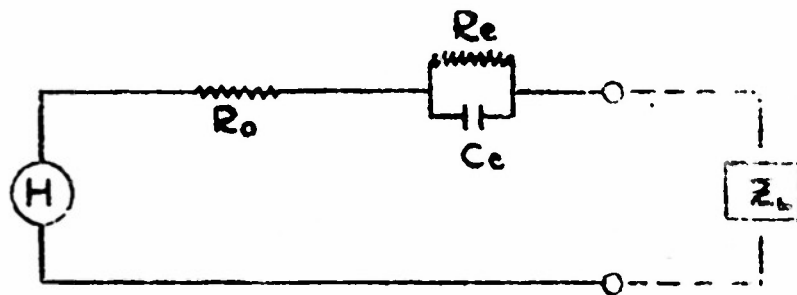
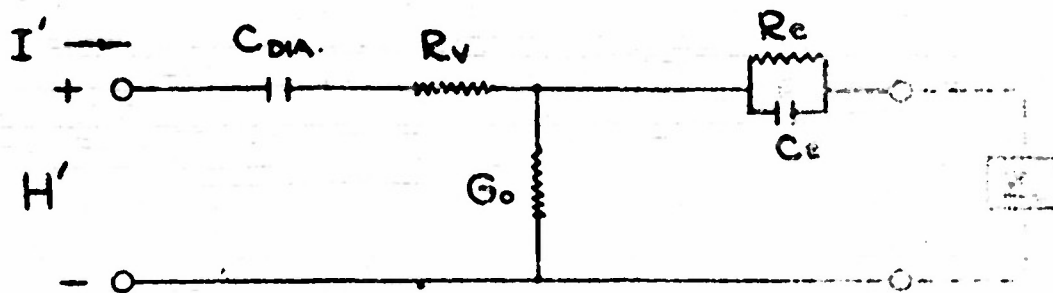

FIGURE 3-7
CIRCUIT SHOWING ELECTRODE ELEMENTS



$$I' = VM$$

$$H' = P/M$$

$$C_{DIA.} = M^2 / K_D$$

$$R_v = \frac{1}{\gamma M^2}$$

FIGURE 3-8
EQUIVALENT CIRCUIT AT LOW FREQUENCIES

The useful upper response range is limited to 20 to 30KC in water with resonance effects above 15KC requiring compensation.

There are several factors which could act to limit the high frequency response of a transducer of this type:

a. The elastance of the porous disc and its clamping means with respect to the instrument case permitting motion of the disc. This has been found to be particularly important in underwater measurements due to the increased mass loading.

b. The inertia of the moving mass of electrokinetic liquid - in air and gas measurements, assuming the porous disc is completely rigid.

c. Transmission of sound through the instrument case to the disc.

d. Capacity of the disc and other transducer parts (assuming a short cable.)

e. Acoustic absorption phenomena in the pores.

f. Possible non-applicability of the basic theory for the origin of streaming potential at high frequencies.

A considerable number of tests were run under varying conditions and with numerous transducer modifications to determine which of the above factors were more important in limiting the high frequency performance. By making impedance measurements, using cork insulation in various parts of the transducers, using materials of widely different porosities, employing different types of clamping means and conducting tests in both air and water, it was concluded that the most important factor up to 30KC was (a), the elastance of the disc and its clamping means, particularly in water. This conclusion was partly verified by the improvement in response in a unit in which the center portion of the disc was masked with wax - on the assumption that the center would most likely vibrate at the greatest amplitudes. The superior air response also indicates this.

An obvious approach to the problem of raising the high frequency underwater response limits for pressures acting on the diaphragm would be to simply use porous discs of stiffer construction, i.e., smaller in diameter or greater in thickness. Although transducers using such ceramic elements have been designed and procurement of the elements initiated, they have not as yet been fabricated or tested at the time of this writing.

It would appear reasonable to assume on the basis of tests conducted thus far that the frequency range may be extended to several hundred kilocycles. On the other hand it would not appear that construction such as shown in Figure 3-2 would ever be likely to be useful in the megacycle range.

Figures 3-9 through 3-15 show typical response curves of data taken during studies of electrokinetic transducers at higher frequencies. In all curves a Brush BM-101 Standard Microphone was used for a reference above 30 cps and an accurately calibrated Statham strain gage transducer was used at 30 cps and below. An arbitrary 2DB correction was made to all readings made with the BM-101 Microphone as its calibration was apparently 2DB in error, as compared to the strain gage.

Figures 3-9 and 3-10 show the air response curve of two Type 4 transducers of the construction shown in Figure 3-2. These and all other tests were made in a standing wave tank with the transducer face flush with one end of the tank and the sound source at the other end. Frequencies were chosen to obtain resonance in the tank and the diaphragm pressure was assumed to be the same as the nearest pressure maxima as determined by the BM-101 calibrated microphone. Note that the usable frequency response of these units extends from the 3db point at less than 0.2 cps in both cases to 30KC which was the highest frequency at which data could be obtained in air with the available test instrumentation.

Figure 3-11 shows the response of a fairly high impedance Type 4 Transducer with a 20 foot cable. The rise in response, (normally encountered with a very small external capacity, and due to elastance effects,) is overcompensated by cable capacity effects in accordance with Equation 15.

Figure 3-12 shows the response of a Type 4 transducer in water where external capacity was purposely minimized. In this unit elastance effects were pronounced.

Figure 3-13 is the response curve of a typical Type 3 transducer as illustrated in Figure 3-1. The longer liquid column and the elastance of the disc support causes a marked resonance at 16 KC. The effects of the resonance can be largely eliminated by external RC networks to obtain reasonably flat response for shock wave measurements to 15 KC. The design in Figure 3-2 is considerably superior from this viewpoint.

Another typical underwater response curve of a Type 4 transducer of different construction is shown in Figure 3-14.

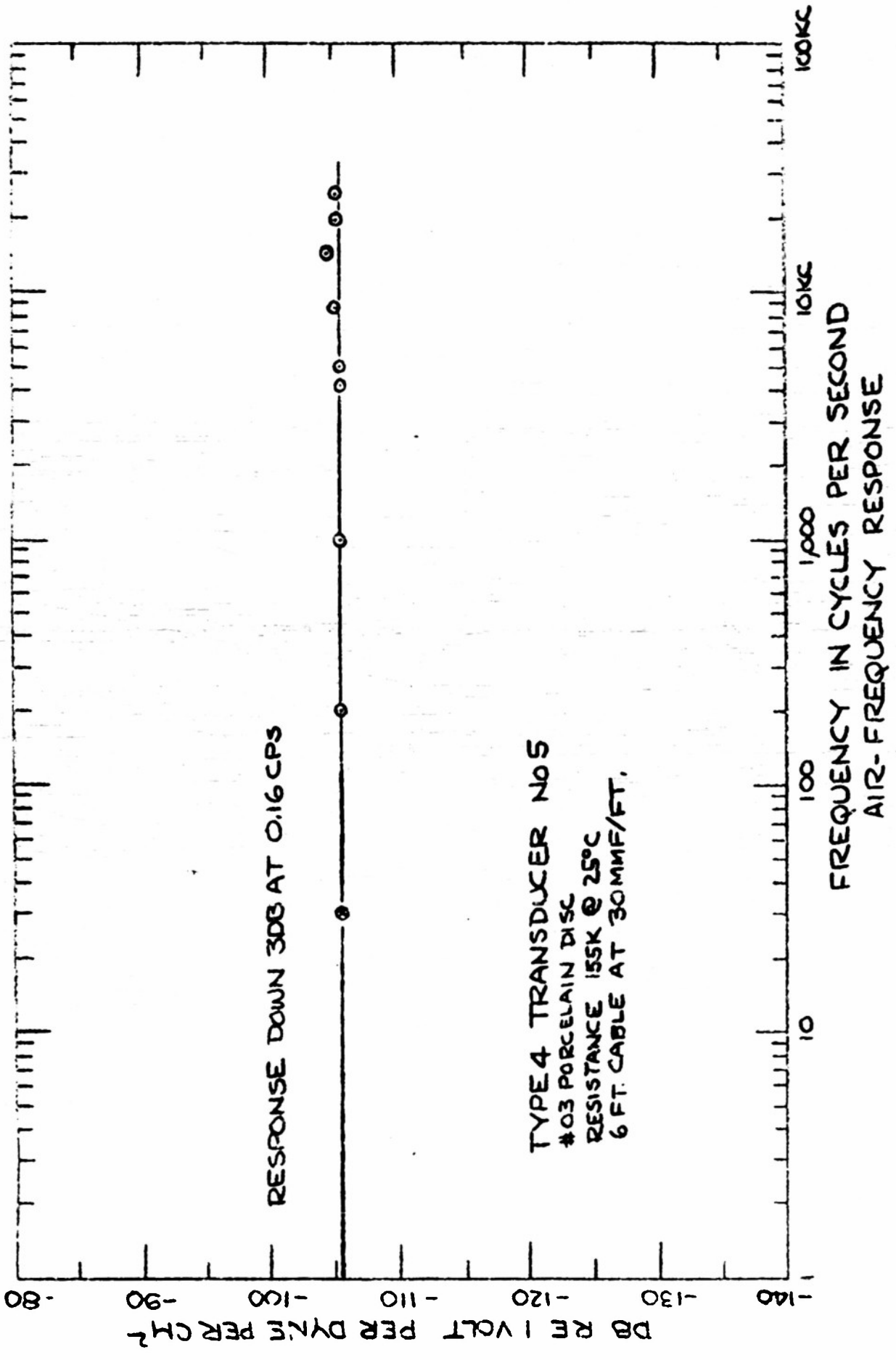

FIGURE 3-9

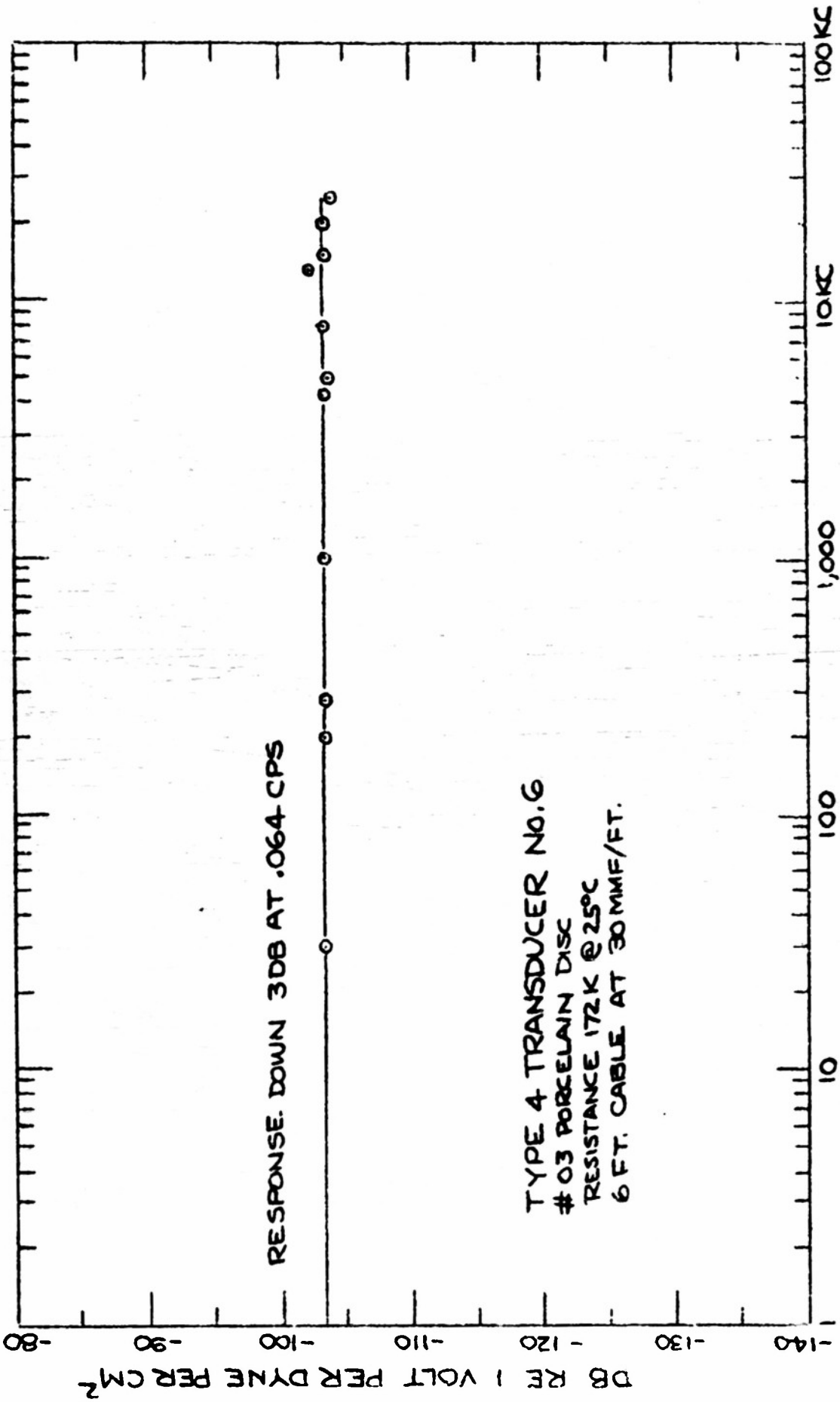
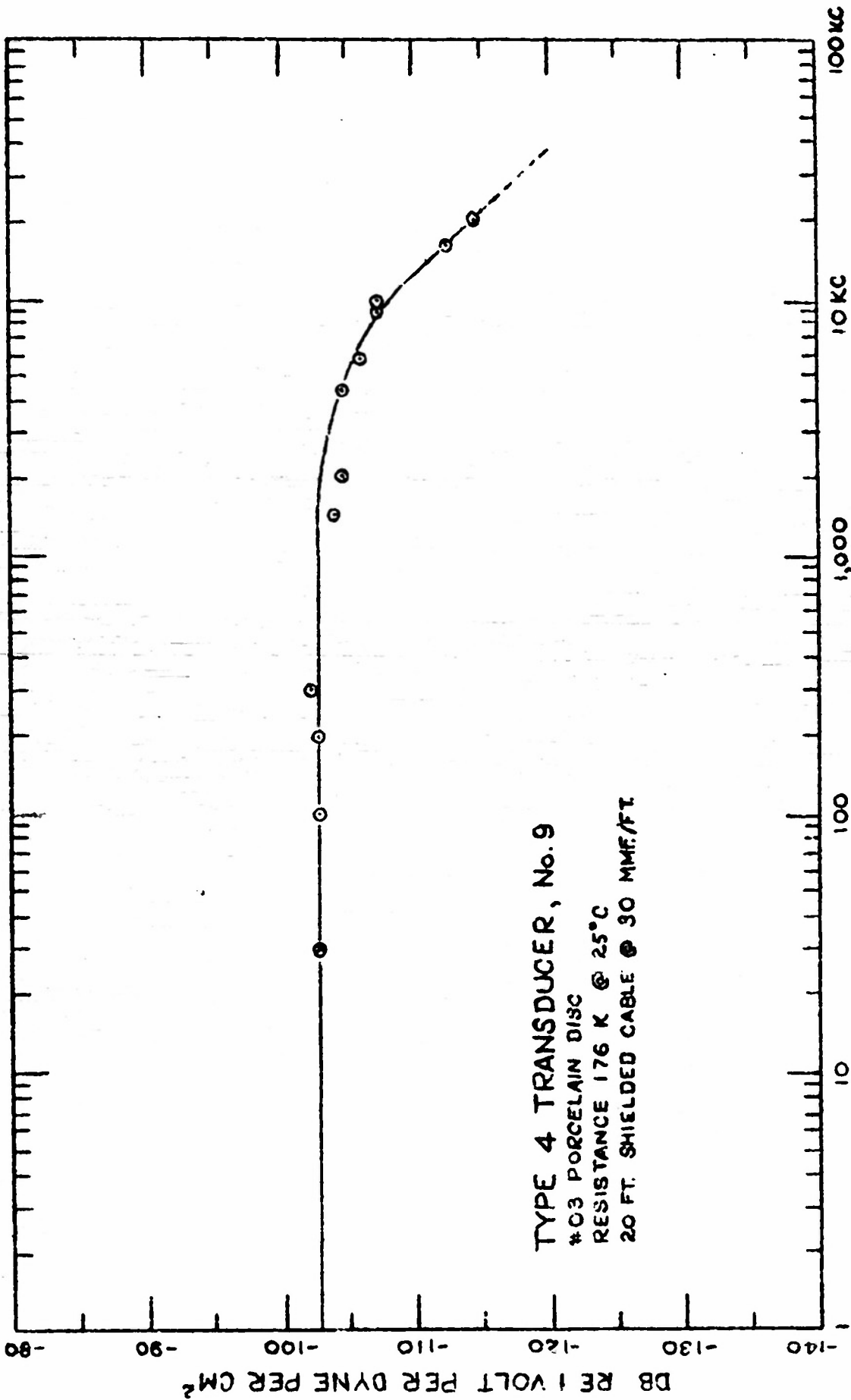

FIGURE 3-10



FREQUENCY IN CYCLES PER SECOND
 AIR - FREQUENCY RESPONSE

FIGURE 3-11

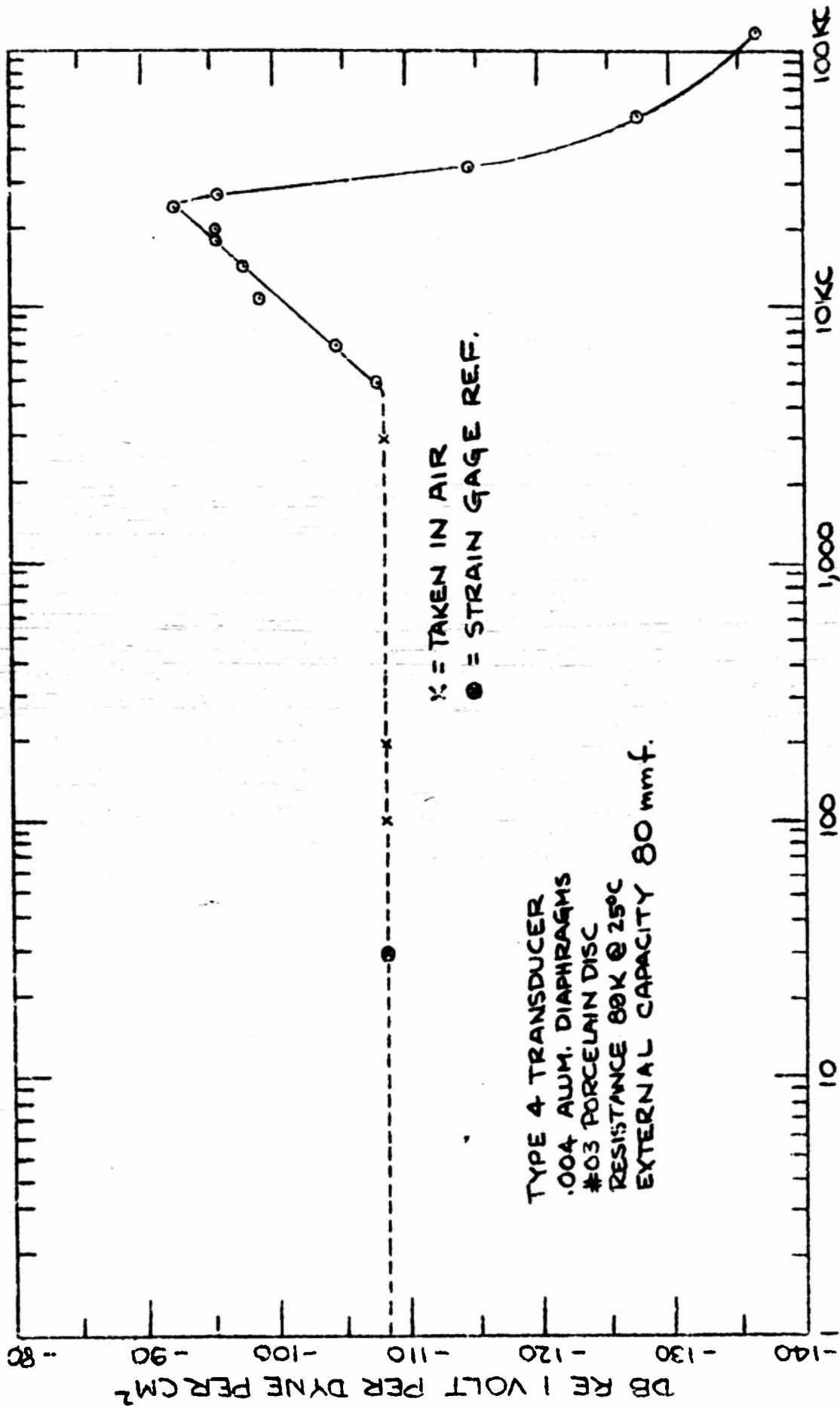
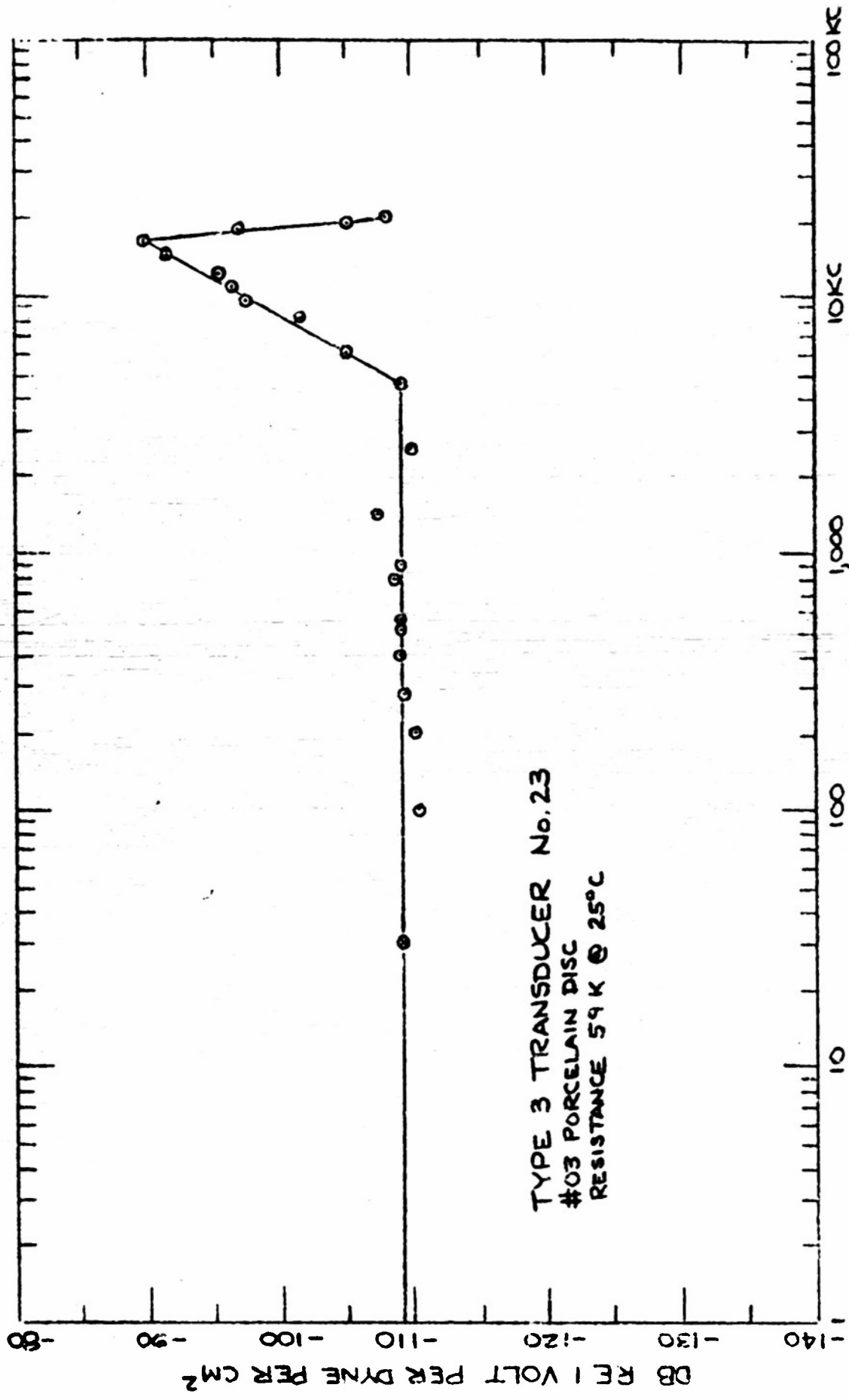

FIGURE 3-12



FREQUENCY IN CYCLES PER SECOND
 AIR-FREQUENCY RESPONSE

FIGURE 3-13

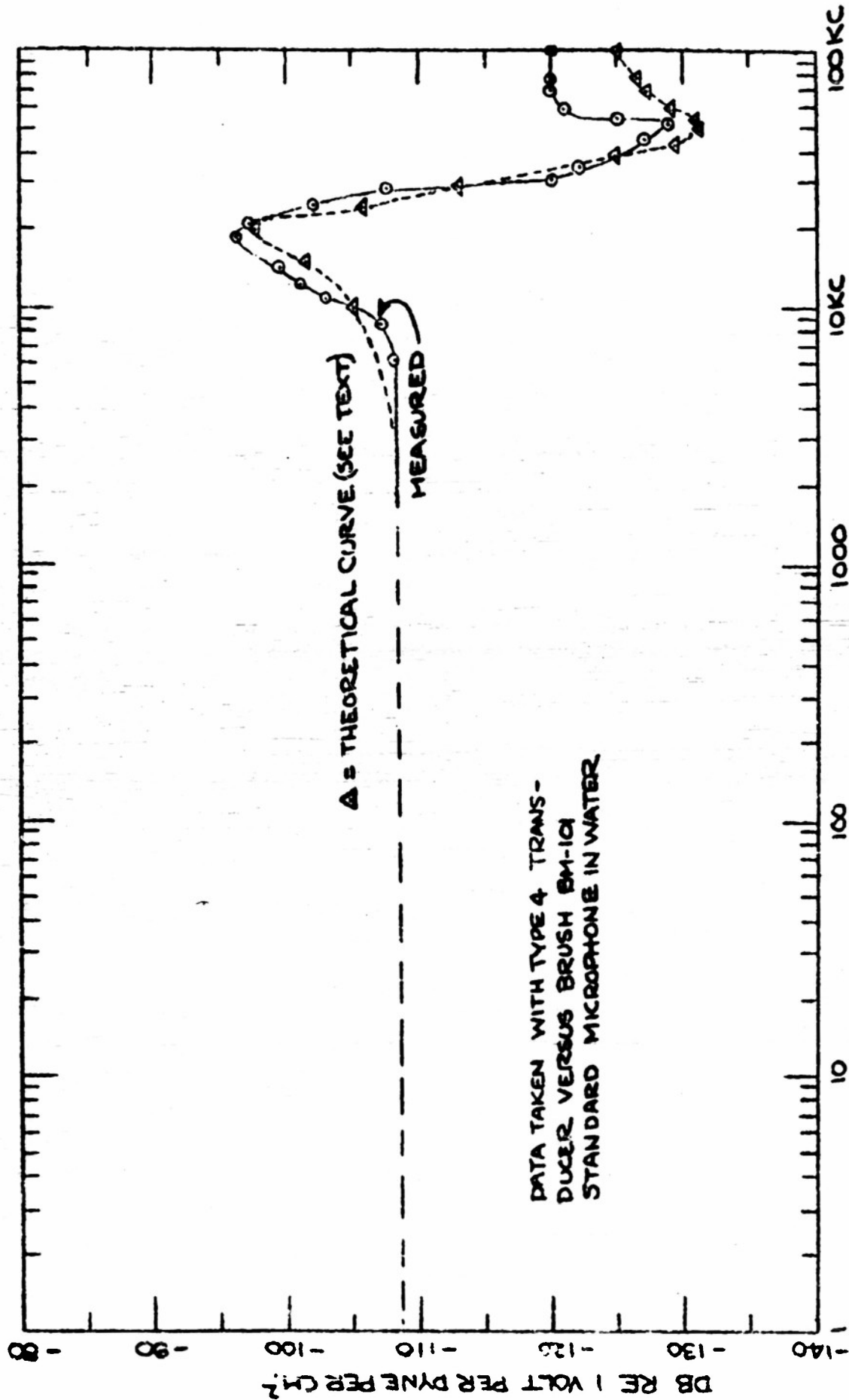
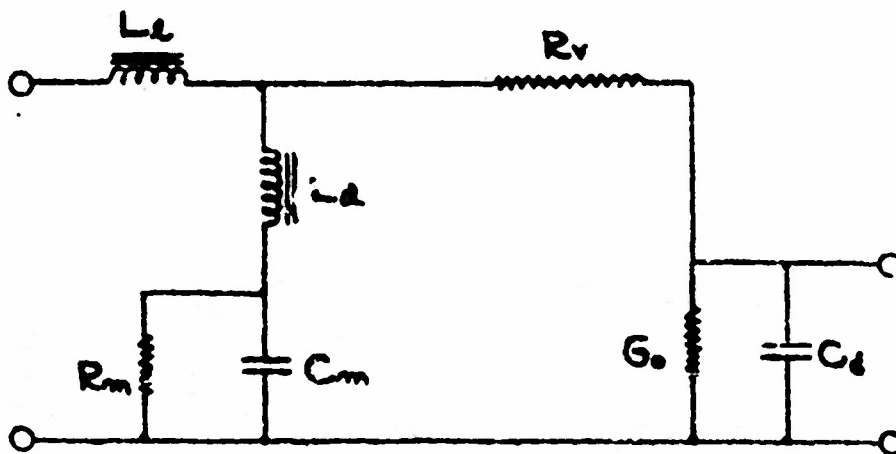

FIGURE 3-14



EQUIVALENT CIRCUIT WHICH ACCOUNTS FOR MASS LOADING IN LIQUID MEDIA, AND THE ELASTANCE AND DAMPING IN DISC AND MOUNT

- L_2 = INDUCTANCE EQUIVALENT OF EFFECTIVE MASS OF LIQUID - INSIDE AND OUTSIDE OF CELL
- L_d = INDUCTANCE EQUIVALENT OF MASS OF DISC AND OUTER RING
- C_m = COMBINED CAPACITANCE EQUIVALENT OF ELASTANCE OF DISC AND CLAMPING MEANS
- R_m = RESISTANCE EQUIVALENT OF DAMPING COEFFICIENT OF MOUNT

FIGURE 3-15

This curve is presented to show the effects of "mass loading" and the elastance of the disc and mount. A theoretical curve is also plotted, based, on the equivalent circuit in Figure 3-15 and the assumptions to be stated below.

The equivalent flow resistance R_v is infinite and may be disregarded in determining the frequency response of the mechanical elements. The effective mass of the surrounding liquid is assumed to be constant. This is not, of course, an accurate assumption, as the impedance of the liquid cannot be represented by a simple function. This assumption is made as a rough approximation for the sake of simplicity. The mass of the disc and outer ring are lumped as an equivalent inductance L_d and the elastance and damping of the mount or clamping means by C_m and R_m .

The response function of the mechanical elements is given then in terms of electrical equivalents by:

$$f(\omega) = \sqrt{\frac{[1 - (\frac{\omega}{\omega_2})^2]^2 + Q_2^2}{[1 - (\frac{\omega}{\omega_1})^2]^2 + Q_1^2}} \quad (21.)$$

Where:

$$\omega_1^2 = \frac{1}{C_m(L_d + L_e)} \quad (22.)$$

$$\omega_2^2 = \frac{1}{C_m L_d} \quad (23.)$$

$$Q_1 = \frac{\omega L_d}{R_m} \quad (24.)$$

$$Q_2 = \frac{\omega(L_d + L_e)}{R_m} \quad (25.)$$

$$\frac{Q_2}{Q_1} = \frac{L_d}{L_d + L_e} = \left(\frac{\omega_1}{\omega_2}\right)^2 \quad (26.)$$

In Figure 3-14, a transducer response curve is shown and an attempt to fit this curve using the above derived expression. All values were obtained for the theoretical curve by making the following assumptions:

$$\omega_1 = 2\pi(20KC)$$

$$\omega_2 = 2\pi(50KC)$$

$$f(\omega_1) = +9.5DB$$

An experimental curve as shown in Fig. 3-14 was not obtained in every case, and the results are not, therefore, conclusive. The reasoning is given, however, as it may be worthy of future consideration, at least, from a qualitative point of view in the design of hydrophones.

Means of improving high frequency response in the design of units to measure very high blast pressures are mentioned in Section 4.6.

As previously stated the ultimate limitations of the high frequency response in air are unknown at the time of this writing as our present instrumentation is limited to 20 KC for accurate air measurements. And again, the most obvious method of achieving improved response in the ultrasonic range in underwater measurements would be to reduce the size and increase the stiffness of the mounting of the porous disc.

3.6 Pressure Range and Linearity:

Tests have been conducted on electrokinetic transducers over an extremely wide range of pressures extending from a few dynes per square centimeter to 95 lbs. per square inch. The ceramic disc elements used in transducers of the type shown in Figure 3-2 have been tested at 165 psi (steady gas pressure) without breakage occurring.

The excellent linearity of this type of transducer was anticipated in view of the very small Reynolds Number in the pores and the low pore velocities. Figure 3-16 shows the linearity of an earlier Type 3 gage at high air blast pressures. This data was taken by the Explosion Effects Division of the Naval Ordnance Laboratory, Silver Spring, Maryland. The blast pressures were produced by one pound spherical cast pentolite charges. Tourmaline piezoelectric gages were used for the comparative measurements.

Figure 3-17 shows the results of sensitivity measurements over a range of roughly 100 to 100,000 microbars (1.45 psi). To permit a wide range of pressures to be measured in the test tank, measurements were made of sensitivity at 5KC, 25KC, 50KC and 120 KC. The average sensitivity for each frequency was obtained and deviation from the mean is plotted in DB as a function of pressure. The resulting plot simply shows that the departures at sound levels are due to experimental errors in making the measurements rather than to any non-linearities. This data was taken on the same unit for which frequency response is plotted in Figure 3-14.

Figure 3-18 shows steady flow data taken with distilled water at 66°F and a 30mm fine porosity fritted glass disc. An ordinary laboratory D.C. vacuum tube voltmeter and a mercury manometer were used in taking this data (on Dec. 6, 1950.) The departures can be accounted for in the reading of the voltmeter scale in the low ranges.

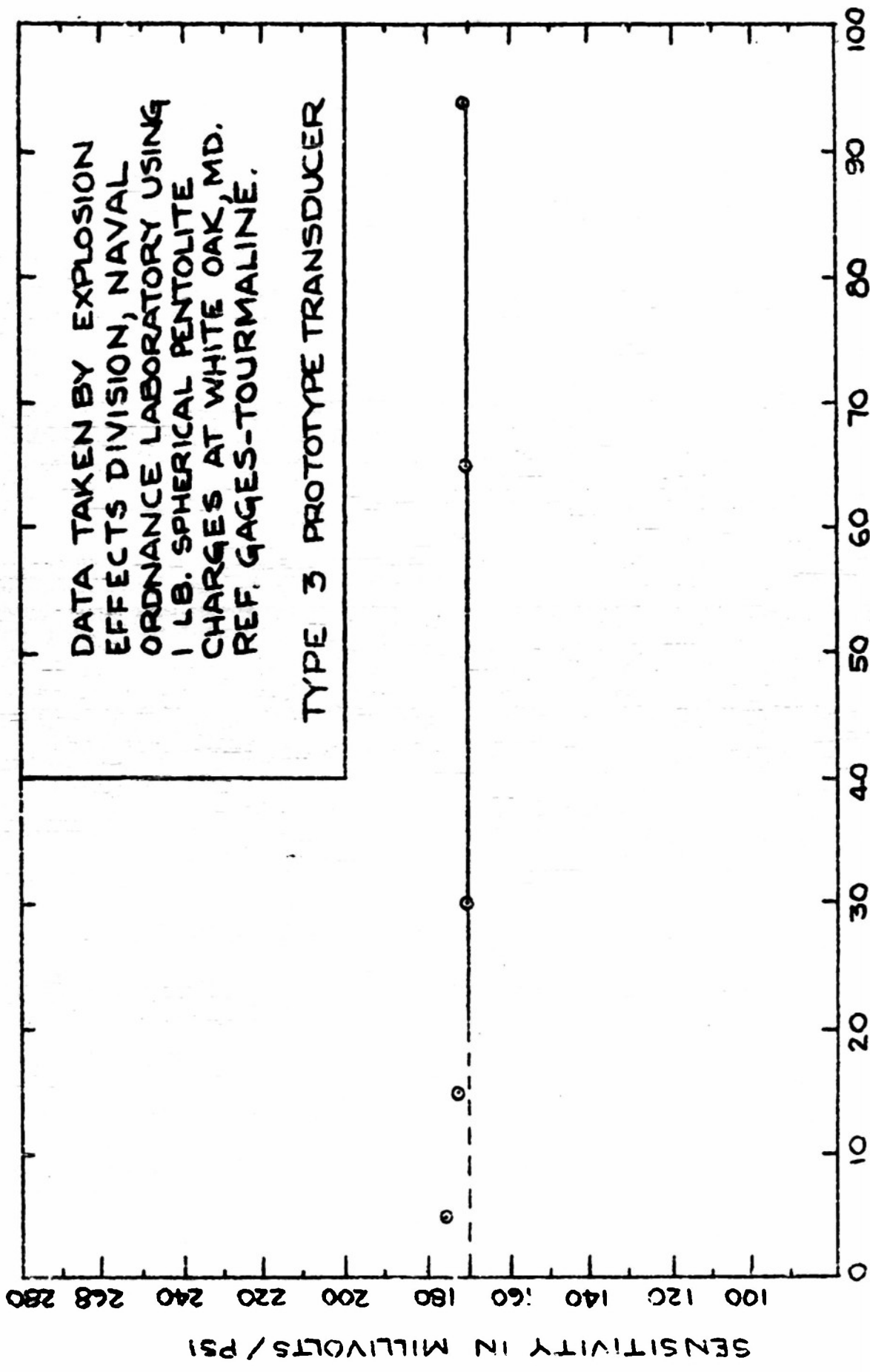

SENSITIVITY VS. PRESSURE

FIGURE 3-16

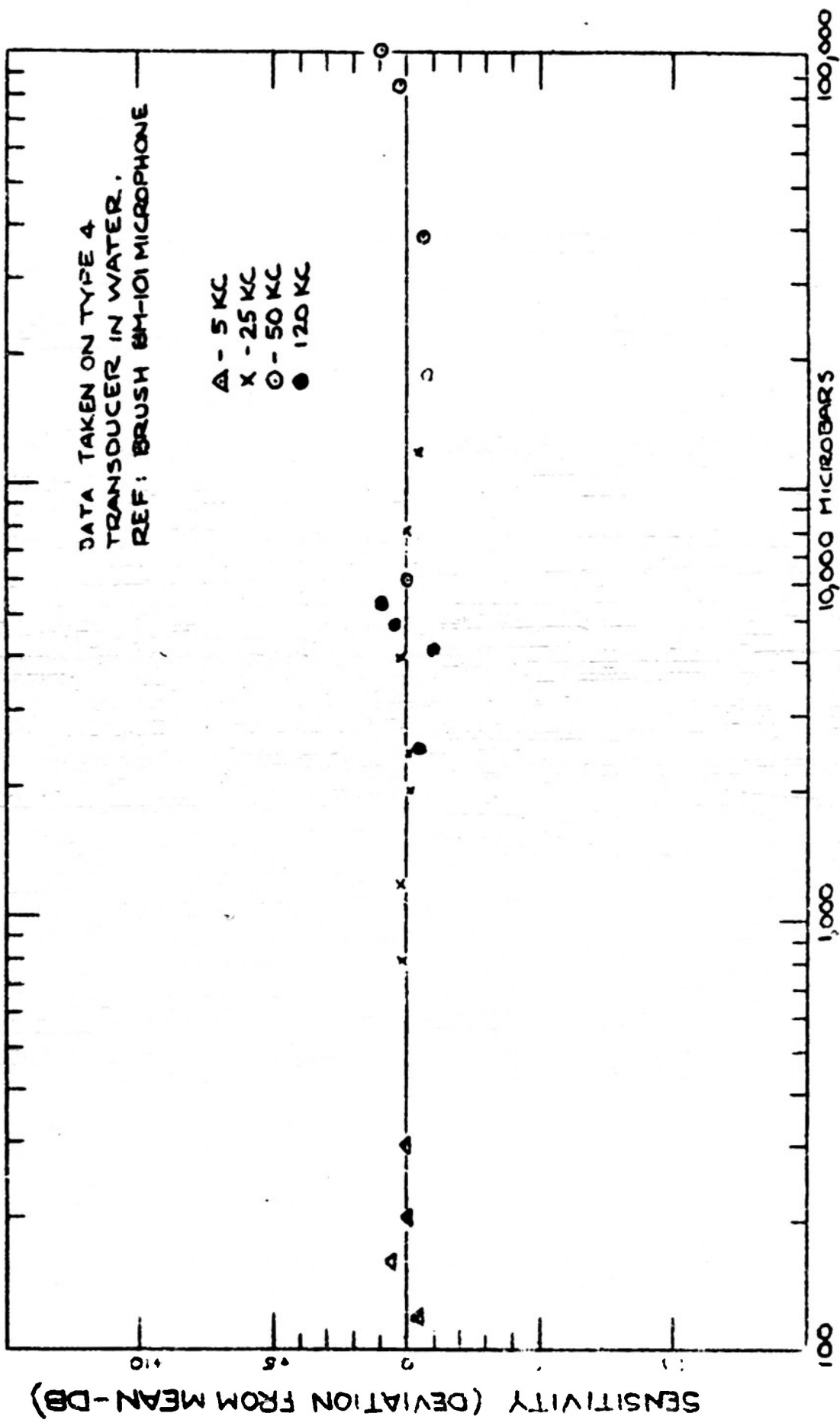

SOUND PRESSURE - MICROBARS
SENSITIVITY VS. PRESSURE

FIGURE 3-17

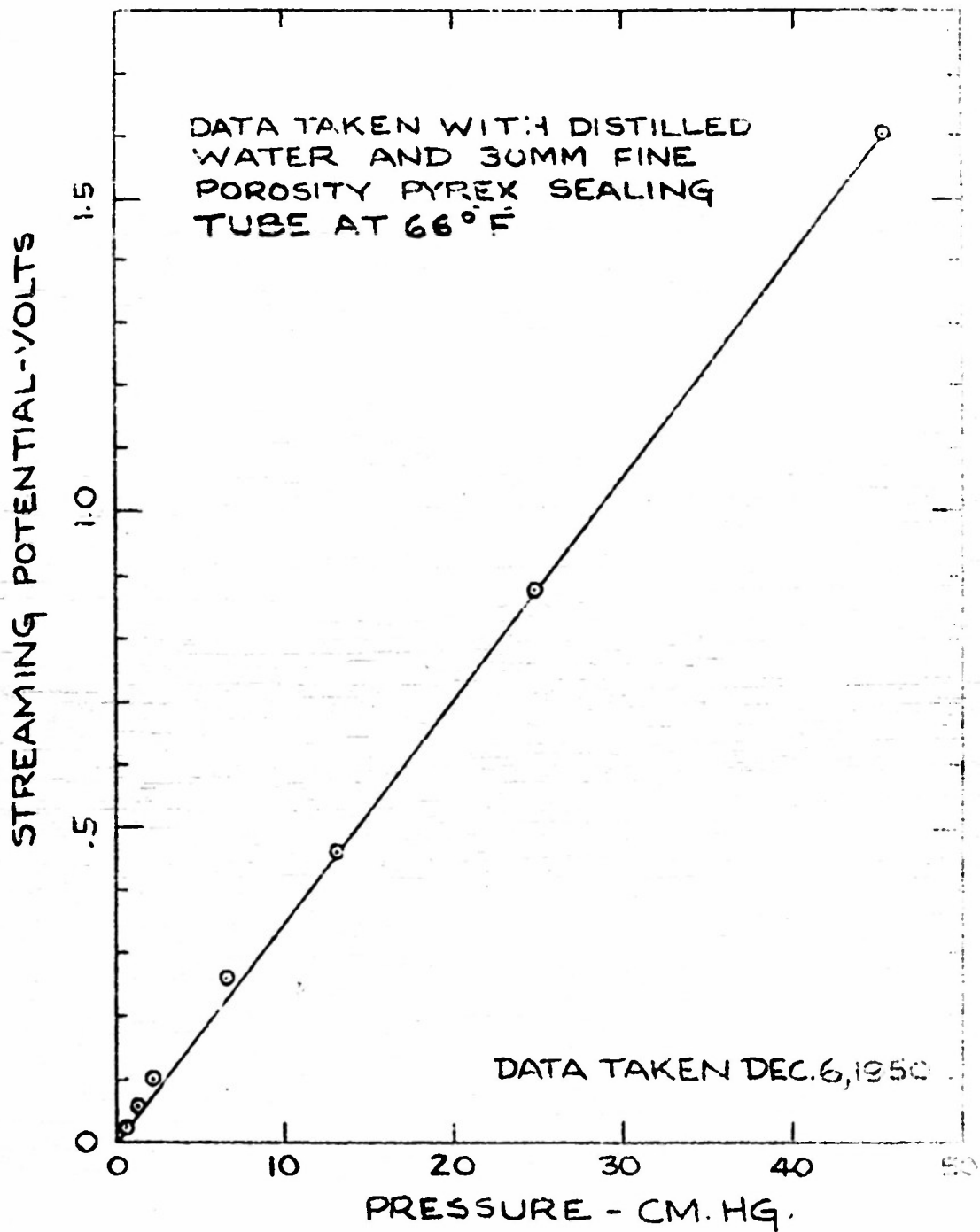

STREAM. POTENTIAL VS. PRESSURE

FIGURE 3-18

Numerous other tests have been made which would have indicated any changes in sensitivity with pressure. In tests made to date, no indications of non-linearity have been present. Linearity is not considered a problem in the design of an electrokinetic transducer.

The pressure operating range for static pressures is limited by the strength of the diaphragm and maximum allowable diaphragm pressure.

The usable dynamic range is dependent on the allowable travel. This can readily be computed for any given design for rectangular pulses or alternating pressures at the maximum operating temperatures.

For example with an .090 thick, .750 Dia. #03 porosity porcelain disc at 60°C the flow resistance is 290 psi/in/sec. The pressure range is therefore limited to:

$$P_{(max)} \leq 2\pi\eta (290) X_0 \quad (27A.)$$

$$P_{(max)} \leq 2\pi\eta (290) \frac{X_0}{T} \quad (27B.)$$

where η is the frequency, T is the pulse length, and X_0 is the allowable (effective) diaphragm travel in inches. For a maximum allowable travel of .010" and a pulse of 10 milliseconds duration the maximum allowable pressure on this basis would be 290 psi. At an alternating frequency of 1 cps, the maximum pressure for the same travel would be 18.2 psi. The range can, of course, be extended for a given pulse length by using discs of lower permeability or by effectively increasing the permissible diaphragm travel.

3.7 Resolution and Noise:

In view of the pressure range, and frequency response range of electrokinetic transducers it is evident that inter-modulation effects should be extremely small, if they exist and resolution would be expected to be excellent. Such transducers whether used to measure pressure or acceleration should give signals capable of being integrated or differentiated by electronic means with excellent results. No information is as yet available other than that which can be inferred from data given in preceding sections.

By using a well shielded battery operated high gain amplifier it was possible to compare the noise originating in the transducers with that originating in ordinary carbon resistors of the same resistance as the transducers. This was done at various cut-off frequencies and the noise level was found to be identical indicating that the thermal noise of an electrokinetic transducer can be predicted by the formula for "Johnson noise". A transducer with a 100,000 ohm resistance would thus be expected to have a thermal noise level of 1.2 microvolts over 1 kilocycle at 25°C. It is evident that the noise level would be extremely low in large low frequency hydrophones.

Methods of increasing signal to noise ratio, when necessary, are discussed in Section 4.2.

3.8 Acceleration Sensitivity:

The acceleration sensitivity of gages as shown in Figures 3-1 and 3-2 can be readily anticipated by computation, since the length of the liquid column and its mass are known. The acceleration sensitivity is:

$$\frac{H}{G} = \left(\frac{H}{P}\right) \rho l g \quad (28.)$$

In convenient units the acceleration sensitivity is:

$$\frac{H}{G} = .0362 \left(\frac{H}{P}\right) \rho l \quad (29.)$$

where:

H/P is in millivolts/psi

ρ is in grams/cc

l is in inches

H/G is in millivolts per G.

In a typical example for $l = 3/16"$, $H/P = 500$ mv/psi and $\rho = .783$ (acetonitrile), the acceleration sensitivity is 2.66 mv/G. This is very small in view of the stated pressure sensitivity.

If the above transducer, for example, 2-1/4" in diameter, weighing 8 ounces, were freely or elastically suspended and were subjected to a shock wave the acceleration response would be 4.2% of the pressure response. It would, of course, be substantially less if rigidly clamped in a rugged baffle.

Acceleration effects could be readily cancelled by incorporating two opposing cells in one transducer housing with only one cell having an exposed diaphragm.

In underwater hydrophones the effect of the acceleration sensitivity would be expected to be negligible except at frequencies where the wave length is short in comparison with the hydrophone dimensions inasmuch as the hydrophone external pressures would be substantially equalized on the case.

In designing accelerometers the liquid column is lengthened and a heavy liquid may be used as described in Section 4.7.

3.9 Efficiency:

Referring to Figure 3-8, it can be seen that at mid-band frequencies the maximum efficiency in delivering power to a load would occur when Z_L is equal to R_o as R_v is normally much greater than R_o . The efficiency, from equivalent circuit, is:

$$E_{ff} = \frac{R_o}{4R_v} = \frac{\beta^2 F^2}{4BK_o\eta} \quad (30.)$$

For $R_o = 60,000$ ohms and $R_v = 29$ megohms the overall efficiency would only be .052%. For very pure liquids the cell resistance can be increased readily to 600,000 ohms (or greater) giving efficiencies of the order of 1% into a matched load. It can be shown from theoretical reasoning that the percent efficiency for zero bulk conductivity, K_B , approaches $(d/r) \times 100\%$, where d is the double layer thickness and r is the average pore radius.

Although the efficiency is low it should be noted that it is equally low or lower for all transducers with flat response characteristics over a wide range of frequencies.

3.10 Electro-osmosis and Electrokinetic Generators:

Little mention has been made of the electrokinetic transducers as generators because of their low efficiency which results from power loss in the conducting liquid and, even in the ideal case, the loss in shearing the liquid in the double layer. No important applications of electrokinetic generators are visualized with the possible exception

of laboratory generators where it is desirable to utilize the wide range, particularly at the low frequency end to generate sound waves or pulses. Low efficiency would limit their usefulness except where power consumption and heat dissipation were not important.

In an electrokinetic generator equation (6) and (7) can be reduced to:

$$I = G_0 H \quad (31.)$$

$$P = - \frac{S(I,P)H}{g_v} H + \frac{V}{g_v} \quad (32.)$$

It is interesting to note that in the case of electro-osmosis with $P = 0$:

$$\left(\frac{V}{I}\right)_{P=0} = \frac{S(I,P)H}{G_0} = - \left(\frac{H}{P}\right)_{I=0} \quad (33.)$$

This equality has been used frequently to check the validity of measurements in electrokinetic apparatus.

When $V = 0$ the electro-osmotic pressure is given by:

$$P = - \frac{S(I,P)H}{g_v} H \quad (34.)$$

This relation may be used to determine the pressure developed by an "electrokinetic pump".

Equivalent circuits such as shown in Figure 3-8 may be used for electrokinetic generators by interchanging the source and load. The same electromechanical coupling constant M is used in the "turns ratio" in impedance conversion.

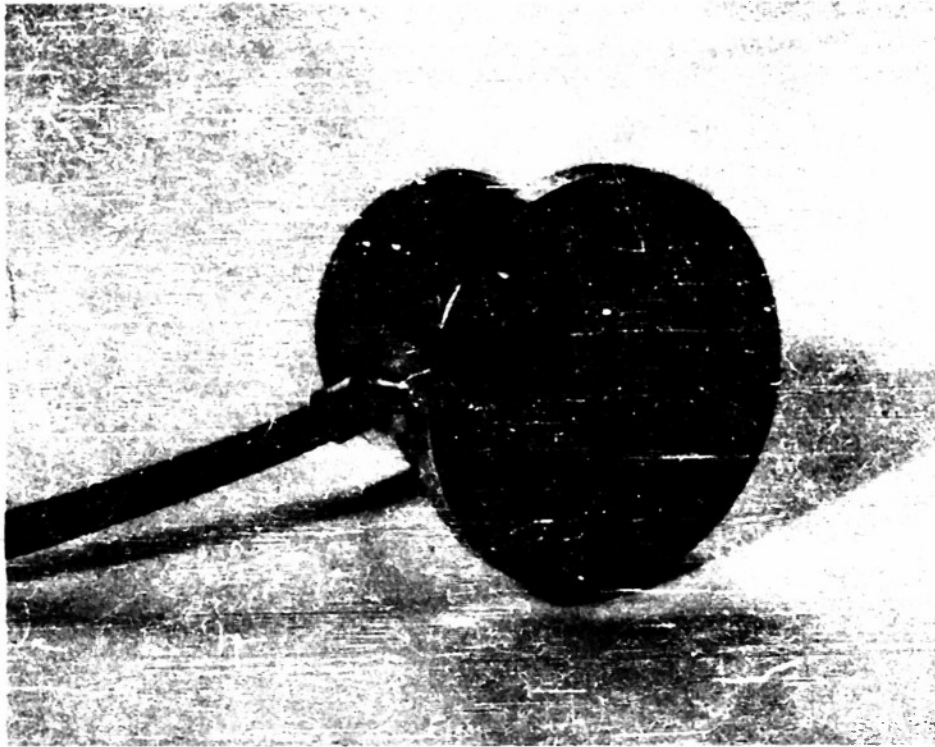

THE TYPE 3 TRANSDUCER

4. FACTORS DETERMINING THE SUITABILITY OF ELECTROKINETIC TRANSDUCERS FOR VARIOUS APPLICATIONS

4.1 General:

The purpose of this section is to discuss in practical terms some of the considerations involved in utilizing electrokinetic transducers for various applications. There are two primary reasons why many possible applications have not yet been realized. First, the idea of employing electrokinetic transducing means in instruments for measuring pressure and the realization of their advantages as to pressure range, independence of temperature, sensitivity linearity and frequency response are new, the most important transducer developments having occurred in the last two years. Secondly, this organization has only recently through listings in the trade journals announced the commercial availability of electrokinetic transducers. In general, the proportion of scientists or engineers who have even heard of electrokinetic transducers is at this time extremely small, and those who have had occasion to become aware of their principles of operation, advantages, and limitations, are fewer still.

It is somewhat early to be writing a section on applications, a subject which we are actually only beginning to explore. Yet certain questions which are likely to arise, can be at least tentatively answered in regard to the probable suitability of electrokinetic transducers for future instrumentation applications.

4.2 Pressure Range:

The high pressure limitations of a transducer of the general construction shown in Figure 3-2 are dependent on the mechanical strength of the porous disc and other mechanical elements. It would appear perfectly practicable to extend the present design to cover ranges up to 1000 psi. The question of linearity of the phenomena itself (which might or might not become a problem) could be overcome by increasing the disc thickness and correspondingly decreasing the pressure gradient. There is no evidence, however, to the effect that linearity would become a problem at such pressures.

The diaphragm travel limitations as discussed in Section 3.6 would have to be taken into account in any design regardless of ultimate range. A special design for explosion pressures so high as to require protection for any glass or ceramic elements is discussed in Section 4.6.

When static or average pressures are high and it is necessary to measure down to relatively low frequencies and amplitudes, for example in measuring pressure pulsations in gas lines, pressure equalizing means must be used. One solution is the use of a differential transducer as shown in Figure 4-1, exposing one diaphragm to the measured region and the other to the average pressure of the measured medium. The latter may be accomplished by using a valve (closed when measurements are made) or an orifice or porous filter damping means to isolate the opposing diaphragm from the pulsations and yet permit static equalization.

The low pressure limitations depend entirely on signal-to-noise ratio which in turn is dependent to a great extent on the resistive output impedance. In this respect it is expected that they will compare favorably with other types of true energy transducers and be substantially superior to devices such as strain gages, "E" type magnetic pickups, and other instruments requiring an external source of electrical energy.

The signal-to-noise ratio could in a number of applications be increased by mechanical amplification as is done in piezoelectric microphones. It could also be increased where size limitations permit, by simply increasing the porous plug area to obtain a corresponding impedance reduction at a given sensitivity.

The noise level, as stated in Section 3.7 is very low in electrokinetic transducers and would be particularly low in applications not requiring use of the full range of frequencies. Excellent response can be obtained in the low frequency range without the use of very high resistive impedances which tend to increase the noise level of piezoelectric devices designed for low frequencies.

4.3 Operating Temperature Range:

The operating temperature range is limited primarily by the boiling and freezing point of the electrokinetic liquid under the absolute pressures to which it is subjected in the transducer. At ordinary atmospheric temperatures this offers no problem. Acetonitrile at atmospheric pressures boils at 82°C and freezes at -41°C. Propionitrile which also has good electrokinetic properties boils at 97°C and freezes at -92°C. For higher temperatures nitrobenzene with a boiling point of 211°C may be used, and there are undoubtedly other compounds with even higher boiling points which could be selected.

For very high operating temperatures it may eventually be found practicable to use liquids sealed under high static pressures to raise their boiling points, particularly if flat response at very low frequencies were not a problem. Inasmuch as the ceramic elements electrodes, etc., are usable to very high temperatures the ultimate limitation might eventually be determined by thermal expansion of the materials, insulation requirements, or other properties related more to the exterior design than to the streaming potential cell components.

4.4 Hydrophones:

One of the most important applications of electrokinetic transducers will probably be in underwater sound pressure measurements. Data taken thus far indicates that such transducers will have definite advantages over existing types in a number of applications, particularly at low frequencies. The important properties related to the suitability of such transducers to underwater sound pressure measurements are given below:

a. Sensitivity comparable to piezoelectric hydrophones in which piezoelectric elements are subjected to hydrostatic pressure.

b. Output impedance substantially lower than piezoelectric types at low frequencies and not a function of frequency. Low frequency range can be extended indefinitely by design without increasing the resistive impedance and noise level.

c. Sensitivity is not a function of cable length.

d. Coupling is ideal in that it is only necessary to isolate water from the electrokinetic liquid by means of a thin diaphragm.

e. Design can be made extremely rugged with no moving parts or close tolerances.

f. No critical or expensive materials are required.

g. Noise level to 1KC would be below the lowest undersea random pressure noise levels, even with a resistive impedance of 100,000 ohms.

The only known limitations pertain to the upper frequency range which will be limited by the output resistive impedance and the cable capacity (when no preamplifiers are used.) The only statements which can be made at this time regarding high frequency underwater applications are:

a. It has not yet been demonstrated that electrokinetic transducers of the type described would be useful in ranges above 30KC. Below 30 KC it would appear that they would be useful, properly compensated, with short cables, or using preamplifiers with cables of any length.

b. Hydrophones for use at great depths will probably be limited to an upper range of below 1000 c.p.s., when preamplifiers are not used, because of cable capacity. As the attenuation will occur at 6dB per octave and will not by its nature reduce signal-to-noise ratio at the higher frequencies, it should be practicable to make the response flat to considerably higher frequencies by simple RC differentiating networks in the surface amplifiers when necessary.

Details regarding specific hydrophone applications will be covered in subsequent reports.

4.5 Differential Pressure Measurements:

With proper external fittings electrokinetic transducers may be used to measure alternating or transient differential pressures.

When measuring differential pressures in liquids or in moist or corrosive gases it is necessary to electrically isolate the rear parts connected to the non-grounded or "positive" electrode. An arrangement such as is shown in Figure 4-1 would be suitable for such applications.

INSULATING LIQUID CHAMBER
AND DIAPHRAGM

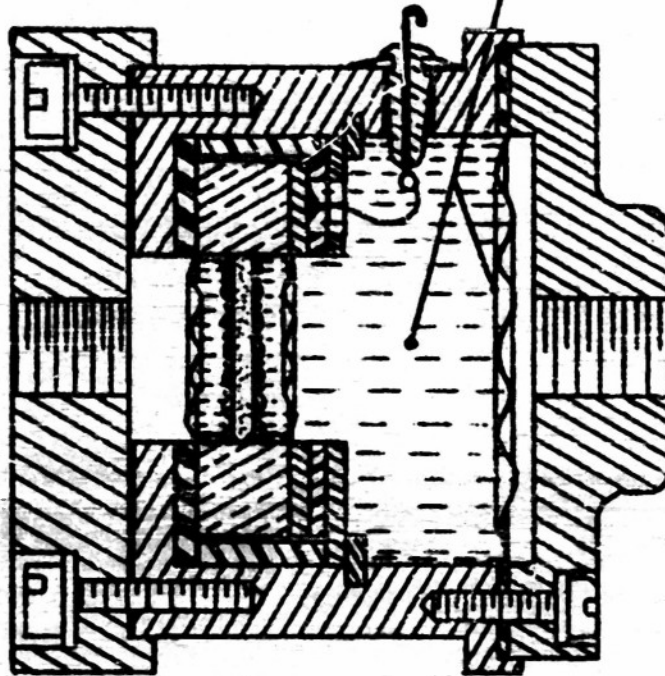

DIFFERENTIAL PRESSURE TRANSDUCER

FIGURE 4-1

In Figure 4-1 the rear portion of the transducer is filled with an insulating oil enclosed by a diaphragm on which the pressure acts. The cell is located on one side by an elastic gasket and is rigidly supported on the other by a metal ring, an insulating washer, a second metal ring and a retaining ring. A wire is soldered to the first metal ring and connected to an hermetically sealed terminal. The other features of such an instrument are self-explanatory.

This type of instrument may be used with a high speed rotary reversing valve to measure very low static values of differential pressure over a range of from a few dynes per square centimeter to several hundred psi. The instrument combined with the valve modulator and an A.C. vacuum tube voltmeter, (with calibration modified for square wave inputs,) would provide a convenient means of measuring pressures too low, or varying too rapidly, to be measured by a mercury manometer.

4.6 Underwater Blast and other Very High Pressure Measurements:

The first electrokinetic transducers developed for the Naval Ordnance Laboratory were designed for air blast measurements up to 100 psi. The units shown in Figures 3-1 and 3-2 are both suitable for pressures of 100 psi as mentioned in Section 4.2.

For the pressures encountered in underwater explosions and the like, a different design would be used employing a metallic pressure reducing plug as shown in Figure 4-2. This design would permit the measurement of pressures of any magnitude depending only on the strength of the case and the porous metal plug.

In this design the strength of the front diaphragm, and cell diaphragms can be greatly increased without loss in low frequency response. It would also be logical to assume that the damping effect of the microporous metal plug would improve the high frequency response considerably, as it would in effect provide rigid means of eliminating vibrations of the porous disc element. The only loss in such an arrangement would be a proportional loss in sensitivity - not important for high blast pressures. In the unit shown, the porous metal plug would be of stainless steel (an available material) either small enough to cause a sufficient pressure drop or used with a viscous oil having nearly the same temperature coefficients as the electrokinetic liquid. It will be evident that if the volumetric flow is the same across the metal plug and the electrokinetic disc element, the ratio of the pressure drops across the two will be a constant. Such an arrangement is made possible by the fact that a finite flow does exist in the electrokinetic cell.

This relationship can be shown mathematically by repeating Equations (6.) and (7.) adding a term to account for the pressure drop across the metal plug.

OUTER DIAPHRAGM

FRONT AND REAR
OIL CHAMBERS

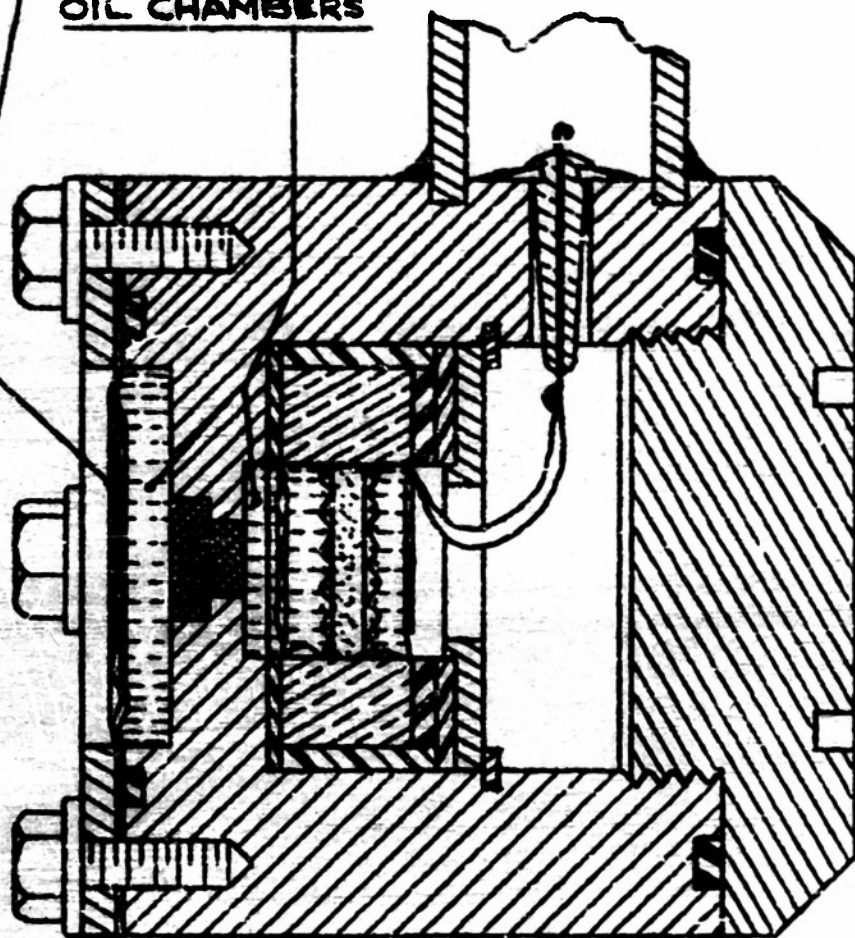

MICROPOROUS METAL
PLUG

ELECTROKINETIC CELL

EXPLOSION PRESSURE TRANSDUCER

FIGURE 4-2

For simplicity r_v the reciprocal of g_v is used.

$$I = S_{(IP)} H r_v V + G_0 H \quad (35.)$$

$$P = -S_{(IP)} H r_v H + (r_v + r_v') V \quad (36.)$$

Setting $I=0$ and dropping the first term on the right in the second equation the equation may be combined to give:

$$\frac{H}{P} = - \frac{S_{(IP)} H}{G_0} \left(\frac{r_v}{r_v + r_v'} \right) \quad (37.)$$

Using a prime to denote quantities related to the metal Plug and the liquid we may write:

$$S_{(IP)} H = \frac{\beta F}{\eta} \frac{A}{t} \quad (38.)$$

$$G_0 = K_0 \frac{A}{t} \quad (39.)$$

$$r_v = \frac{\eta}{B} \frac{t}{A} \quad (40.)$$

$$r_v' = \frac{\eta'}{B'} \frac{t'}{A'} \quad (41.)$$

and

$$\frac{H}{P} = \frac{\beta F}{\eta K_0} \left[\frac{1}{\left(\frac{\eta'}{\eta}\right) \left(\frac{B}{B'}\right) \left(\frac{A}{A'}\right) \left(\frac{t'}{t}\right) + 1} \right] \quad (42.)$$

This Equation is equivalent to Equation (12.) except for the bracketed term which represents the proportion of the pressure drop across the electrokinetic cell to the total. The bracketed term will not be dependent on temperature provided that liquids are chosen so that η'/η is a constant. When complete independence is necessary the same liquid may be used and the same reduction achieved as with a viscous liquid, by increasing B/B' , A/A' and t'/t .

It should be noted that the increase of fluid flow resistance will make possible the measurement of pulses of longer duration for a given pressure in the low ranges and will extend the low frequency range in proportion to the pressure loss for the same effective diaphragm elastance.

The loss in sensitivity is proportional to the gain in maximum allowable pressure. A 500 mv per psi cell which will withstand 100 psi would have a sensitivity of 5 mv/psi incorporated in a transducer as shown in Figure 4-2 designed for 10,000 psi.

Microporous stainless steel and other metals are available with tensile strengths of 15,000 psi. The compressive strength of a small plug would be considerably greater.

4.7 Linear Acceleration Measurements:

The acceleration sensitivity of electrokinetic cells was discussed in Section 3.8. From this discussion it was evident that an electrokinetic transducer could be used to measure acceleration by subjecting the case to the unknown acceleration and by using the relation:

$$H/G = .0362 (H/P) \rho l$$

again where:

ρ is the liquid density in grams/cc.

H/P is the pressure sensitivity in millivolts per psi.

l is the length of the liquid column.

and H/G is in millivolts per G.

It will also be evident that in general all of the previously developed dynamic relationships will be applicable.

The acceleration sensitivity can be increased by increasing "l" the length of the liquid column between diaphragms.

A convenient means of producing a high sensitivity is shown in Figure 4-3. In this unit the sensitivity is given by:

$$H/G = .0362 \left(\frac{H}{P} \right) [\rho l + \rho' l'] \quad (43.)$$

where the primes refer to the heavy liquid column.

An instrument as shown, 2-1/2" in length, was developed for the measurement of the low frequency vibrations over the precordium. It employed mercury as the heavy liquid and was designed for a frequency range from 0.5 cps to 100 cps. This instrument had a sensitivity of 410 millivolts per G which was ample to observe the beating of the heart on a 304E oscillograph without preamplification. (A double integrating amplifier will provide velocity and displacement records to be superimposed on the same chart with traces from the electrocardiograph.)

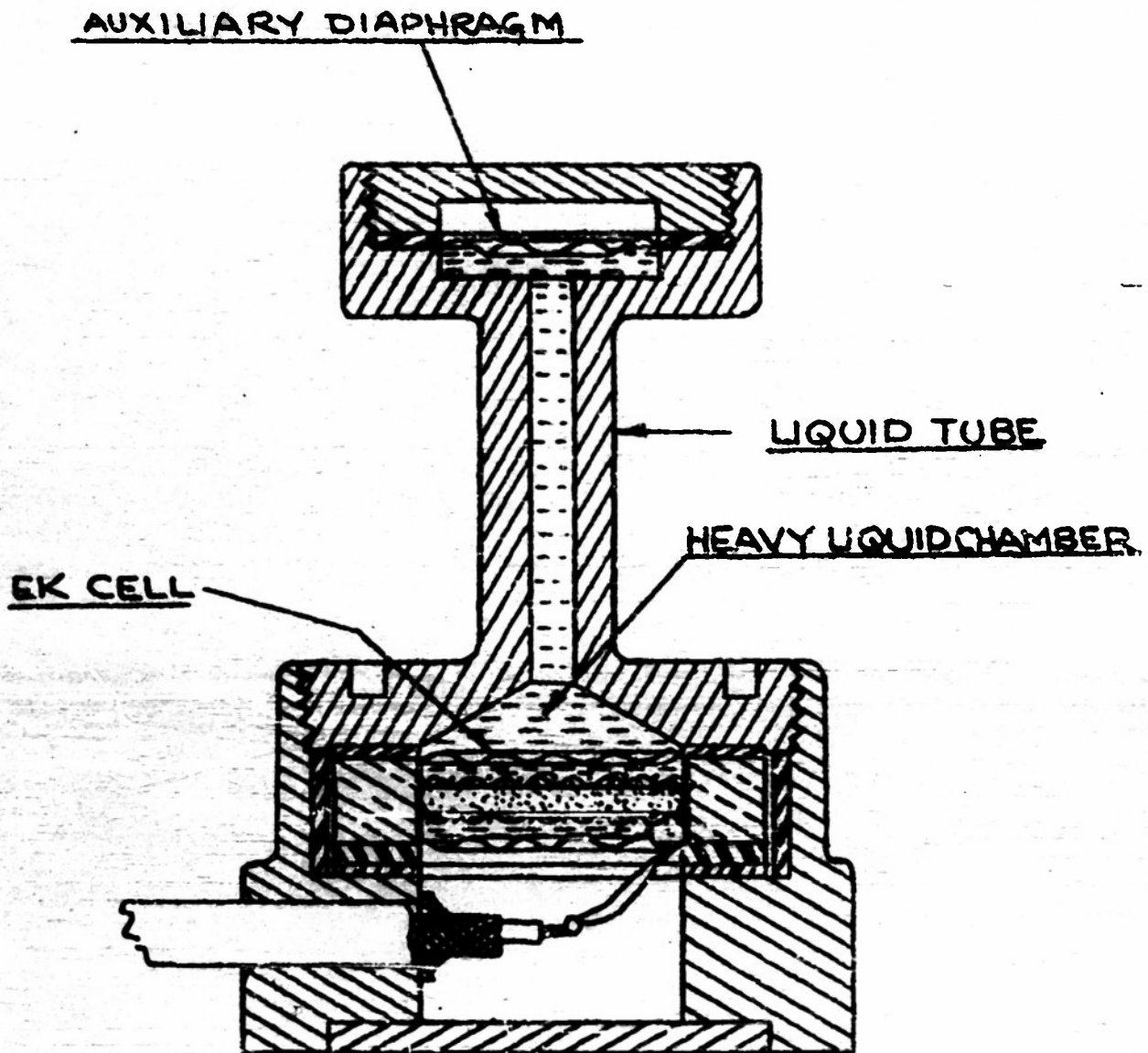

ELECTROKINETIC ACCELEROMETER

FIGURE 4-3

The problem of elastance in the disc and clamping means is important at high frequencies in electrokinetic accelerometers because of the increased liquid mass. Development work is being conducted on the applications of electrokinetic transducers to acceleration measurements at the present time. This includes the use of piston multipliers to reduce the overall length for high sensitivities.

4.8 Angular Acceleration Measurements:

To measure angular acceleration it would be simply necessary to employ a toroidal tube filled with a polar liquid and with a porous plug restricting the flow at some point in the tube. With electrodes on each side of the porous plug the angular acceleration may be measured about the axis of the toroid, the sensitivity being given by:

$$\left(\frac{H}{\alpha}\right) = 2\pi \left(\frac{H}{P}\right) \rho y^2 \quad (44.)$$

In a multiturn helix of N turns it would be:

$$\left(\frac{H}{\alpha}\right) = 2\pi N \left(\frac{H}{P}\right) \rho y^2 \quad (45.)$$

In the above relations ρ is the density of the electrokinetic liquid and y is the radius of gyration of the liquid in the toroidal tube from the axis of rotation. It is evident that such an accelerometer would be insensitive to angular or linear acceleration about or along any other axis.

4.9 Velocity and Displacement Measurements:

As is the case with most other types of transducers, electrokinetic transducers may be used to measure velocity, displacement, and other physical quantities besides pressure and acceleration. Several important considerations are involved in adapting an electrokinetic cell to measure various quantities:

a. Open circuited the voltage sensitivity H/P can be made independent of temperature.

b. Short circuited (i.e. operated into a low impedance load) the current-velocity sensitivity I/v is independent of temperature when "M" is constant. If velocity is measured open circuit, compensation must be made for changes of viscosity by means of an NTC resistor.

c. The dynamic response characteristics must take into account the additional elements or the effect on elements previously considered.

Figures 4-4A through 4-4D show schematically several means of employing electrokinetic transducers to measure vibratory velocities and displacements. The sensitivities are not multiplied by the response function $f(\omega)$ as these functions in each case may be obtained by well known methods.

In Figure 4-4A an electrokinetic accelerometer output is integrated to obtain velocity. Double integration may be done to obtain displacement as shown in 4-4C. Such methods would be particularly applicable where no fixed references are available. Examples are in measuring the impact deflection of waves striking the hull of a ship or in measuring the vibrations of an airplane wing in flight.

In Figure 4-4B velocity is measured by coupling directly to the diaphragm. In this case the response at low frequencies is not affected by the diaphragm, hence ω_L is zero. When a load is used such that $R_L \ll R$, the current-velocity sensitivity is independent of temperature inasmuch as "M" the electromechanical coupling constant is substantially independent of temperature for most liquid-solid combinations.

In Figure 4-4D a simple spring is added to obtain voltage proportional to displacement. (This principle is to be used in measuring relative low frequency heart beat displacements over the chest wall within a fixed span to eliminate the ballistic displacement components.) In this type of instrument the effective elastance of the added spring must be added to that of the two cell diaphragms, in computing the low frequency response. An illustration of such a transducer is on the last page of this report.

4.10 A Comparison with Piezoelectric Transducers:

Direct analogies cannot be drawn between electrokinetic transducers and any other known types. Several properties are unique.

From the point of view of applications (excluding the angular accelerometer) they correspond closely in some respects to piezoelectric transducers particularly in that neither type will function at zero frequency. Both are true energy conversion devices not requiring external sources of power. Their sensitivities in some applications are comparable. The sensitivity of a typical electrokinetic transducer will be about 45DB below an ordinary air microphone (because of mechanical amplification in the microphone) and 40DB above typical piezoelectric devices used for shock wave and blast measurements. (The latter are loaded with sufficient capacity for a given circuit resistance and consequent noise level to provide flat response below 1 cps.)

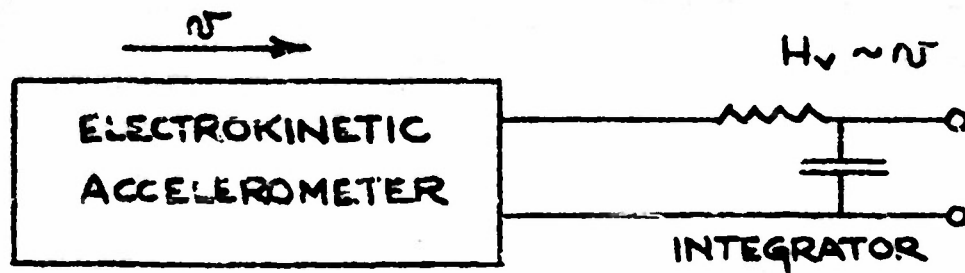

FIGURE 4-4A (VELOCITY)

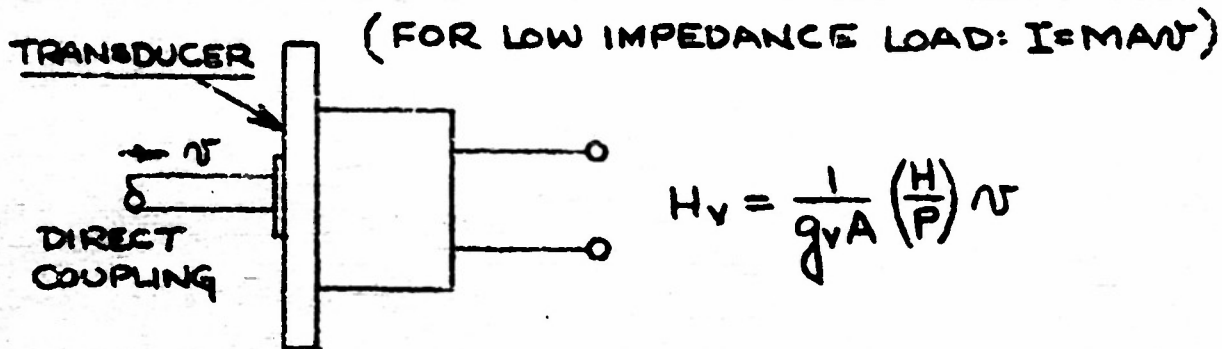

FIGURE 4-4B (VELOCITY)

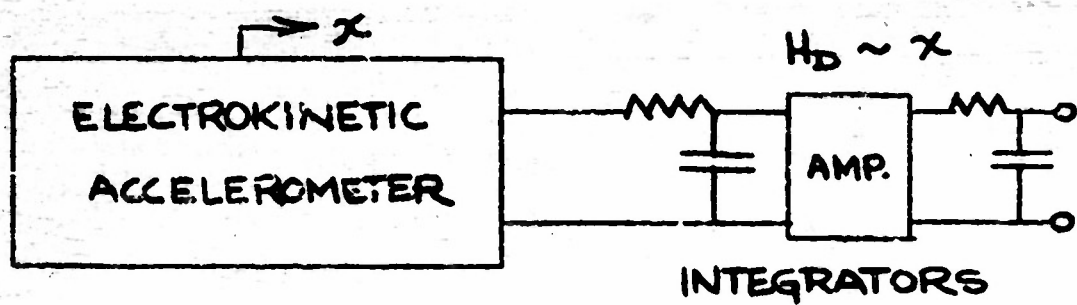

FIGURE 4-4C (DISPLACEMENT)

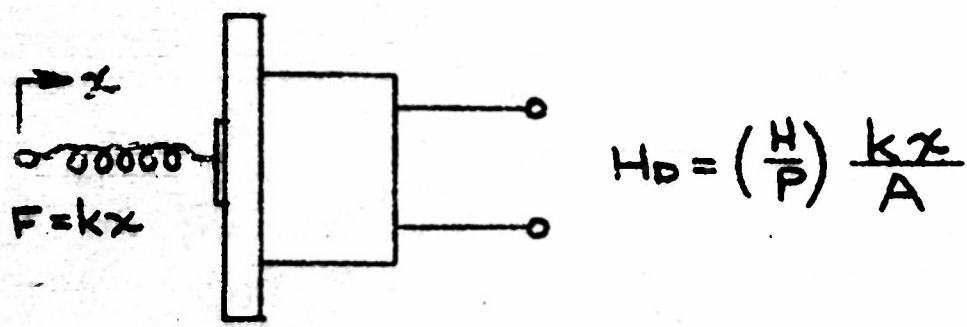

FIGURE 4-4D (DISPLACEMENT)

The output impedance of piezoelectric devices is capacitative and consequently a function of frequency. If a typical unit with a capacity of .005 microfarad were used in an application which required 3DB response to 1 cps the circuit resistance would be at least 30 megohms. It is evident that the thermal noise level per cycle band width would be $\sqrt{300}$ or 17.3 times greater than for a typical electrokinetic transducer of comparable sensitivity and with an impedance of 100,000 ohms, and that the sensitivity of the piezoelectric device would have to be reduced a factor of 17.3 in signal-to-noise ratio.

From the above it may be seen that a principal advantage of the electrokinetic transducer over the piezoelectric is that the impedance is resistive and independent of frequency. This advantage is most significant in the low ranges i.e., from, say, .01 cps to 1000 cps, and in every case where the response of a transducer must be flat to frequencies below 1 c.p.s. for the accurate reproduction of transients or low frequency phenomena.

In ranges above 1000 c.p.s. no general advantages can be pointed out for electrokinetic transducers. Reasonable comparisons could only be made for specific applications where ranges of operation, ambient temperatures, size, weight, etc., were specified.

In conclusion a list of advantages and disadvantages of electrokinetic transducers is given which may be used for comparison with other known types of transducers.

ADVANTAGES OF ELECTROKINETIC TRANSDUCERS

1. "Self-generating" - require no external calibrated power source.
2. High sensitivity - independent of temperature.
3. High resolution and low noise level - suitable for use where operations of differentiation or integration are to be performed on output signal.
4. Wide useful pressure range - roughly 1,000,000 to 1 in same instrument.
5. Sensitivity independent of cable length or load capacity.
6. Wide frequency response - same instrument useful in range from a fraction of a cycle per second to 30 KC or above.
7. Constructed of non-critical, inexpensive materials, and require no close machining tolerances.

8. High signal-to-noise ratio at all frequencies.

DISADVANTAGES OF ELECTROKINETIC TRANSDUCERS

1. Must be connected to high impedance loads unless correction for sensitivity is made based on impedance of unit.
2. Units must be individually calibrated. Present state of art does not permit sensitivity to be predicted precisely prior to assembly and stabilization.
3. Not useful for measuring static quantities.
4. High frequency response limit affected by cable length or load capacity.
5. Acceleration sensitivity may cause difficulties in some low pressure applications where vibration is severe.
6. Elastance effects may limit applicability to frequencies below 30KC.
7. Resistive output impedance a function of temperature (must be compensated with low impedance loads.)

5. REFERENCES

- (1.) Williams, Milton, The Reviews of Scientific Instruments, vol. 19, No. 10, 640-646. October 1948.
- (2.) Williams, Milton, U.S. Patent No. 2,615,940**
- (3.) Abramson, H.A., Electrokinetic Phenomena and their Application to Biology and Medicine*, The Chemical Catalog Publishing Co., New York, 1934.
- (4.) Gortner, Ross Aiken, Rosa Aiken, Jr., and Willis Alway, Outlines of Biochemistry, Wiley, 1950. Chapter 6.
- (5.) Shizuo Ueda, Akira Watanabe, and Fukuji, Tsuji, Study on Surface Electricity (1) on the Theory and Application of the U-Effect., Memoirs of the College of Agriculture, Kyoto University, No. 67, July 1950. (Also Studies on Surface Electricity 2, 3, and 4.)
- (6.) G. Quincke, Pogg. Ann., 113, 513 (1861); cf. also Pogg. Ann., 107, 1 (1859)
- (7.) H. Helmholtz, Wied. Ann., 7, 337 (1879); Wiss. Abhandl., 1, 855 (1822.)
- (8.) D. R. Briggs, J. Phys. Chem., 32, 641 (1928)
- (9.) Hardway, E. V., Jr., ; Electrokinetic Transducers, Nov. 1950. (Informally Distributed.)
- (10.) Hardway, E. V. Jr.; Electrokinetic Transducers and their Future Military Applications, August, 1951 (Informally Distributed)
- (11.) The Beta Corporation, Technical Report No. 1, A Generalized Theory Regarding the Conversion of Energy by Electrokinetic Means, ONR Contract Nonr-617(00), February 27, 1952.

* Contains thorough treatment of electrokinetic phenomena with historical background and references.

** Other Transducer patents pending.

6. DEFINITIONS OF SYMBOLS

- A Area
- B Permeability of porous plug. (Defined by Eq. 16)
- C Capacity
- C_s Equivalent polarization capacity of electrodes
- C_d Internal capacity of electrokinetic cell
- C_{DIA} Electrical equivalent capacity of diaphragm elastance
- d Thickness of Helmholtz double-layer
- e Charge per unit area of double-layer
- F Porosity of plug or effective pore area per unit area
- G Acceleration in "G" units
- G_0 Electrical Conductance of porous plug
- g Acceleration of gravity
- G_V Flow conductance of porous plug
- H Potential difference
- I Current (in external circuit)
- k Stiffness
- k_d Equivalent stiffness of diaphragms in pressure per unit displacement
- K Electrical Conductivity
- K_B Bulk conductivity of liquid
- K_0 Equivalent conductivity of liquid filled porous plug
- K_0, K_s Equivalent conductivity in capillary or pore including surface conductance
- L Electrical inductance
- L_d Electrical inductance equivalent of mass of disc and ring
- L_1 Electrical inductance equivalent of effective mass of liquid in liquid media

l	Length of capillary or liquid column referred to in text
M	Electromechanical coupling constant
m	Mass
n	Frequency
n_L	Low frequency limit (3DB attenuation)
N	Number of pores, capillaries, etc.
P	Pressure
Q	Electrical defined by $\omega L/R$
r	Radius of pore or capillary
r_v	Flow resistance of porous plug
R	Resistance
R_0	Resistance of plug in electrokinetic cell
R_m	Resistance equivalent of damping of mount
R_v	Electrical equivalent of flow resistance of plug
$S_{(IP)H}$	Current-pressure sensitivity of electrokinetic cell with voltage equal to zero
$s_{(ip)h} = S_{(IP)H}^t$	a characteristic electrokinetic property of the liquid-solid combination
t	Thickness of porous plug
T	Time Constant
T_L	Low frequency time constant
T_m	Mass time constant
V	Volume velocity
v	Linear velocity
v_d	Linear velocity of inner layer of double layer
x	Displacement
y	Radius of gyration
Z	Impedance
Z_L	Load Impedance

DB Decibels (Referred usually to 1 volt per microbar)

MW Molecular Weight

ρ Electric moment of the double-layer or charge per unit area times thickness

η Viscosity

ρ Density

ω Angular frequency

G Acceleration in "G" units

ζ Zeta potential of double-layer

ϵ Dielectric constant (refers to liquid in pores)

