

UNCLASSIFIED

AD NUMBER

AD008142

CLASSIFICATION CHANGES

TO: unclassified

FROM: secret

LIMITATION CHANGES

TO:  
Approved for public release, distribution unlimited

FROM:  
Distribution authorized to U.S. Gov't. agencies and their contractors; Foreign Government Information; NOV 1952. Other requests shall be referred to British Embassy, 3100 Massachusetts Avenue, NW, Washington, DC 20008.

AUTHORITY

DSTL, AVIA 6/23497, 12 Feb 2009; DSTL, AVIA 6/23497, 12 Feb 2009

THIS PAGE IS UNCLASSIFIED

Reproduced by

Armed Services Technical Information Agency

**DOCUMENT SERVICE CENTER**

KNOTT BUILDING, DAYTON, 2, OHIO

**AD -**

**8 1 4 2**

**SECRET**

**SECRET**



**ROYAL AIRCRAFT ESTABLISHMENT**

FARNBOROUGH, HANTS

TECHNICAL NOTE No: AERO.2211

**LOW SPEED TUNNEL TESTS WITH  
JET FLOW REPRESENTED ON A  
1/5th SCALE MODEL OF A  
TWIN JET FIGHTER WITH AN  
UNSWEPT WING AND V-TAILPLANE  
(SUPERMARINE N9/47)**

by

**CONTRIBUTED BY SGT ANGLAS D.I.C.**

1. THIS INFORMATION IS DISCLOSED ONLY FOR OFFICIAL USE BY THE RECIPIENT GOVERNMENT AND SUCH OF ITS CONTRACTORS, UNDER SEAL OF SECRECY, AS MAY BE ENGAGED ON A DEFENCE PROJECT. DISCLOSURE TO ANY OTHER GOVERNMENT OR RELEASE TO THE PRESS OR IN ANY OTHER WAY WOULD BE A BREACH OF THESE CONDITIONS.
2. THE INFORMATION SHOULD BE SAFEGUARDED UNDER RULES DESIGNED TO GIVE THE SAME STANDARD OF SECURITY AS THAT MAINTAINED BY HIS MAJESTY'S GOVERNMENT IN THE UNITED KINGDOM.

THIS DOCUMENT IS THE PROPERTY OF H.M. GOVERNMENT AND ATTENTION IS CALLED TO THE PENALTIES ATTACHING TO ANY INFRINGEMENT OF THE OFFICIAL SECRETS ACT, 1911-1939.

It is intended for the use of the recipient only and for communication to such officers under him as may require to be acquainted with its contents in the course of their duties. The officers exercising this power of communication are responsible that such information is imparted with due caution and reserve. Any person other than the authorised holder, upon obtaining possession of this document, by finding or otherwise, should forward it, together with his name and address, in a closed envelope to:-

THE SECRETARY, MINISTRY OF SUPPLY, MILLBANK, LONDON, S.W.1.

Letter postage need not be prepaid, other postage will be refunded. All persons are hereby warned that the unauthorized retention or destruction of this document is an offence against the Official Secrets Act.

SECURITY INFORMATION



**SECRET**

53AA-4760

AD No. 8142

ASTIA FILE COPY

**SECRET**

U.D.C. No. 533.652.1.011.3(42) Supermarine N9/47:533.695.75:  
533.69.048.2:533.6.013.412/415:533.6.013.43/152

Technical Note No. Aero 2211

November, 1952

ROYAL AIRCRAFT ESTABLISHMENT, FARNBOROUGH

Low speed tunnel tests with jet flow represented on a  
1/5th scale model of a twin jet fighter with an  
unswept wing and V-tailplane (Supermarine N 9/47)

by

D. A. Kirby, B.Sc., A.C.G.I., D.I.C.

R.A.E. Ref: Aero W/S 1952/R

SUMMARY

Low speed tunnel tests have been made on the Supermarine N 9/47 to check the effects of the jet flow on the longitudinal stability and to test the V-tailplane. Measurements of the velocity distribution behind the exit have been made to check the effectiveness of the jet exit fillet in keeping the jet flow clear of the rear fuselage.

Estimation of the reduction in static stability margin using the results of previous work (Meteor and Vampire) gave fair agreement with the measured reduction. Modifications to the jet exit fillet were tested and found to increase its effectiveness.

**SECURITY INFORMATION**

SECRET

SECURITY INFORMATION

Tech. Note No. Aero 2211

LIST OF CONTENTS

	<u>Page</u>
1 Introduction	4
2 Model Details	4
3 Details of Tests	4
4 Results and Discussion	5
4.1 Velocity distributions behind the jet exit	5
4.2 Longitudinal stability	5
4.21 Jet effects on lift and pitching moment	5
4.22 Application to full scale conditions	7
4.3 Lateral and directional stability	8
5 Conclusions	9
References	9
Advance Distribution	10

APPENDIX

Assumptions made in estimating the jet effects without tailplane

LIST OF TABLES

	<u>Table</u>
Model data	I
Data used in applying model results with cold jets to full scale conditions	II
Trimmed lift coefficients	III
Longitudinal stability without tailplane	IV
Longitudinal stability with tailplane	V
Thrust contribution to lift and pitching moment	VI
Flow contribution to lift and pitching moment without tailplane	VII
Tailplane contribution to pitching moment	VIII
Experimental results and estimates of the jet effects on pitching moment	IX
Directional stability without tailplane, original jet exit fillet	X
Lateral and directional stability without tailplane, modified jet exit fillet	XI
Lateral and directional stability with tailplane, modified jet exit fillet.	XII

SECRET

Tech. Note No. Aero 2211

LIST OF ILLUSTRATIONS

	<u>Fig.</u>
G. A. of model	1
Jet exit fillets, side and plan views	2
Jet exit fillets, cross sections	3
Velocity traverse behind the original and modified jet exit fillets at zero tunnel speed	4
Velocity distribution behind the modified jet exit fillets at zero tunnel speed	5
Velocity distribution behind the modified jet exit fillets, $\frac{V_{exit}}{V_0} = 1.75$	6
Trimmed lift coefficients	7
Pitching moment coefficients	8
Effect of flow on pitching moment of model without tailplane	9
Effect of flow on tailplane contribution to pitching moment	10
Effect of incidence on the change in $C_m$ due to flow, no tailplane	11
Effect of incidence on the change in $\Delta C_{m_{tailplane}}$ due to flow	12
Effect of incidence on the change in $C_L$ due to flow, no tailplane	13
Overall effect of jet flow on pitching moment at maximum steady thrust	14
Yawing moment coefficients	15
Rolling moment coefficients	16
Sideforce coefficients	17

Detachable Abstract Cards.

## 1 Introduction

The present method<sup>1</sup> of estimating the effect of a jet on the static longitudinal stability of an aircraft depends to a large extent on tests made on two models (Meteor and Vampire). The two engines of the N 9/47 are in the body, and the exits near the side of the body aft of the wing trailing edge; the jet axis at the exit is downwards and outwards relative to the body centre line (Figs.1 and 2). This layout is very different from the previous arrangements, so that tests on the N 9/47 were desirable to check the jet effects on stability and also to check the design of exit fillets required to prevent the jet "sticking" to the rear fuselage.

## 2 Model Details

A 1/5th scale model of the aircraft was used for the tests. The duct centre line, and the area and flow direction at the entries and the exits were represented correctly; the centre part of the duct was distorted so that internal fans could be fitted. No boundary layer bypass was represented. Sawyer motors were used to drive four fans, two in each duct, to provide a cold jet. Pitot combs were fitted at the exits to measure the flow and internal thrust.

No ailerons or elevators were cut, but the tail setting could be adjusted. Transition wires were fitted to the fuselage behind the intakes and over the cabin. Full details of the model are given in Table I, a general arrangement drawing in Fig.1 and a drawing of the original and modified jet exit fillets in Figs.2 and 3. The exit fillets are discussed in Section 4.1.

## 3 Details of Tests

The tests were made in the No.1 11½ ft × 8½ ft tunnel at the R.A.E. during the period March-July 1951. Wind speeds of 80 and 120 ft/sec were used, giving Reynolds numbers of 0.82 and  $1.23 \times 10^6$  based on the standard mean chord of the wing.

The technique of representing the flow in a jet engine by model fans using cold air is discussed in Ref.1.

Tests were made as follows:-

- (a) A static test showed that the modified jet exit fillet (first modification) deflected the jet from the side of the fuselage better than the original design; and this modified fillet was used for the stability tests.
- (b) The flow distribution behind the exit was measured at  $\frac{V_{\text{exit}}}{V_0} = 1.75$ , including the effect of sideslip.
- (c) Measurements of  $C_L$ ,  $C_D$  and  $C_m$  were made with the fans windmilling ( $\frac{V_{\text{exit}}}{V_0} = 0.9$ ) and with  $\frac{V_{\text{exit}}}{V_0} = 2.25$  and 3.4. It was necessary to reduce the tunnel speed from 120 ft/sec to 80 ft/sec to obtain  $\frac{V_{\text{exit}}}{V_0} = 3.4$ .
- (d) Measurements of  $C_n$ ,  $C_y$  and  $C_\xi$  were made with the fans windmilling and of  $C_n$  and  $C_y$  with  $\frac{V_{\text{exit}}}{V_0} = 2.25$ .

SECRET

Tech. Note No. Aero 2211

(e) The second modification to the jet exit fillet was made on one side of the model. The effect on the flow behind the exit was obtained but no stability measurements were made.

The coefficients with fans windmilling have been corrected to zero thrust conditions ( $\frac{V_{\text{exit}}}{V_0} = 1.0$ ) before presentation in this report.

#### 4 Results and Discussion

##### 4.1 Velocity distribution behind the jet exit - tests with various jet exit fillets.

For the N 9/47 a jet exit fillet is required to prevent over-hot air "sticking" to the rear fuselage. The original jet exit fillet was a concave projection from the body, but as it did not follow a cylinder with the jet centre line as axis, it seemed likely that over-hot air might not be kept sufficiently clear of the body.

Hot air was not obtainable for the tunnel test, so velocity traverses behind the fillet (Fig. 2) have been made to assess the efficiency of the fillet in controlling the jet flow. Since the exit is near the wing wake it is not easy to interpret the velocity measurements in terms of heat. For the static case (zero tunnel speed) 35% of the maximum jet velocity was obtained at the side of the fuselage with the original fillet (Fig. 4).

Two modifications to the jet exit fillet were therefore tried (Figs. 2 and 3). For the first of these the general size of the fillet was unaltered, but it formed part of a cylinder giving the jet direction, though it was not symmetrical about a generator. This fillet diverged more from the body direction than the original, and sharper edges were provided to help the flow break clear of the body. The second modification was designed to assist the flow of cold air between the body and jet; the channel between the jet exit and body was deepened, the fillet made shorter and symmetrical about a cylinder generator, and the fillet was supported on a slightly undercut fairing.

The effect of either modified fillet was to reduce the velocity at the side of the fuselage from 35% to 5% of the maximum jet velocity. The results are shown in Figs. 4 and 5.

Following the static test various flow measurements were made with wind on, suggesting that an improvement might be obtained in this case also. All the results are not given since their quantitative interpretation in terms of heat is not possible because of the wake of the wing and engine housing. The two distributions shown in Fig. 6 demonstrate the superiority of the second modification in keeping the higher velocities away from the body.

##### 4.2 Longitudinal stability

###### 4.21 Jet effects on lift and pitching moment

The jet flow causes changes in lift and pitching moment, because there is:-

- (1) a thrust lift and moment
- (2) a change of downwash at the tailplane

(3) a lift and pitching moment due to the change of direction of the jet on entering the duct and to the further change of direction inside the duct.

(4) an interference between the jet and the body near the exit.

Calculations for (1), (2) and (3) can be made as follows:-

(1) is calculated by considering the thrust as the change of momentum which occurs between the free stream and the exit (see Appendix and Table VI).

(2) is calculated by Squire<sup>1,2</sup>. Since the N 9/47 has a V-tailplane the jet effect on the downwash angle is calculated at several spanwise stations and an integration made across the span. In finding the effect on pitching moment the measured value of  $\frac{\partial C_m}{\partial \eta} = 0.04$  has been used.

For (3) Squire<sup>1</sup> has shown that the change of direction of the air entering the duct gives rise to a lift acting in the plane of the entry which is proportional to the mass flow and the sine of the angle between the jet axis and the stream direction. With an entry at the side of a body the local stream direction is inclined to the free stream direction because of the upwash due to the wing and body field. At the N 9/47 entry position one chord ahead of the wing, the upwash due to the wing alone would be small, of the order of 10% of the wing incidence. Because the effect of the body on this value is uncertain no allowance has been made for upwash when using Squire's formula. For the N 9/47 the calculated lift in the plane of the entry is therefore  $0.0281 \frac{V_{exit}}{V_0} \sin \alpha_D$ , where  $\alpha_D$  is the incidence of the duct centre line at the entry to the free stream direction. There is a further lift of  $0.00082 \left(\frac{V_{exit}}{V_0}\right)^2$  due to the bend in the duct. The full details of the calculations are given in the Appendix.

In comparing the calculated values of the various jet effects with the experimental, (2) can be studied directly by considering the model results with and without tailplane for various jet flows. (3) and (4) can only be obtained together from the experiment. In Tables VII and VIII the measured jet effects on lift and pitching moment are given relative to the lift and pitching moment obtained with zero thrust  $\left(\frac{V_{exit}}{V_0} = 1\right)$ .

All the calculations have been made using this exit flow as a datum.

Considering first the model without tailplane, the measured jet effect on pitching moment (thrust moment removed) is plotted in Figs. 9 and 11. The estimated value for (3) above is given and is lower than the measured value of (3) and (4) together, suggesting that interference of the jets on the body near the exits is appreciable. The overall lift change due to the jet flow is mainly the lift component of the thrust (Table VI). The remainder is nearly zero whereas the calculated value of (3) would be a small positive lift (Fig. 13), so that the interference near the exits is a negative lift. This is consistent as regards direction with the pitching moment mentioned above and at low incidence a position near the jet exits is given for this negative lift. The result is not affected by the omission of an upwash angle from the calculations, but with the present model the doubt about the upwash angle prevents any further analysis at higher incidences.

The jet effect on the tailplane depends on the exit momentum so the pitching moments have been plotted in Fig.12 as

$$\frac{\Delta C_m}{\frac{V_{\text{exit}}}{V_0} \left( \frac{V_{\text{exit}}}{V_0} - 1 \right)}$$

against the wing incidence. The estimated values agree reasonably.

#### 4.22 Application to full scale conditions

Table II gives the model exit velocity ratios for the mass flow and exit momentum corresponding to maximum steady thrust at sea level and 40,000 ft. The range of exit momentum used in the model tests is inadequate to cover sea level flight above a lift coefficient of 0.4 ( $\alpha = 6^\circ$ ), but will cover flight at 40,000 ft up to a lift coefficient of 0.6 ( $\alpha = 8^\circ$ ). At the test Reynolds number the wing stalls at lift coefficients just greater than 0.6 (Fig.8).

The results have been used to deduce the flight pitching moments for a range of lift coefficient at sea level and 40,000 ft by:-

- (i) removing the thrust components of lift and pitching moment from the measured values for the model without tailplane.
- (ii) finding the lift and pitching moment applicable to the exit velocity for correct mass flow.
- (iii) adding to (ii) the thrust components as deduced from the correct exit momentum.
- (iv) adding to (iii) the tailplane contribution applicable to the correct exit momentum.

In using the correct mass flow and in determining the correct thrust lift the incidences corresponding to the final trimmed lift coefficients with thrust are used. The results are expressed relative to pitching moments when  $\frac{V_{\text{exit}}}{V_0} = 1.0$ ; allowance has been made for the change in datum between the incidence corresponding to a trimmed lift coefficient with  $\frac{V_{\text{exit}}}{V_0} = 1.0$  and the incidence corresponding to the same  $C_L$  with thrust.

Table IX shows the various components of the jet effect and the overall effect on pitching moment is plotted in Fig.14. This figure shows the following changes in stability margin:-

/Table

Reduction of static stability margin caused by jet flow

Maximum steady thrust with a C.G. position at 0.199c

Trimmed $C_L$	Sea Level		4,0,000 ft	
	From Experiment	From Estimate	From Experiment	From Estimate
0.1	0.053c	0.052c	0.010c	0.015c
0.2	0.057c	0.056c	0.015c	0.021c
0.3	0.066c	0.059c	0.025c	0.027c
0.4	0.077c	0.061c	0.033c	0.033c
0.5			0.041c	0.036c
0.6			0.048c	0.036c

4.3 Lateral and directional stability

The effect of sideslip on the flow into the ducts and the jet interference with the body at the exit cannot be calculated but Figs.15 and 17 show that varying the flow gives only small changes in the yawing moment and sideforce. The tests were nearly all made with the first modified fillet. Tables X and XI show that replacing the original by the first modified fillet gave little change in  $C_n$  and  $C_y$ .

The model measurements have been analysed to find the effects of the jets on directional stability by adding the V-tailplane contribution at the correct exit momentum to the coefficient without tailplane at the correct mass flow. This gives  $n_v$  for the complete model as

$\alpha^\circ$	Trimmed $C_L$	$\frac{V_{exit}}{V_0}$		$n_v^*$	
		Correct Mass flow	Correct exit momentum	Correct conditions	With zero thrust
<u>Sea Level</u>					
2.05	0.11	1.03	2.06	0.051	0.041
<u>40,000 ft</u>					
2.05	0.11	1.01	1.37	0.046	0.041
7.6	0.535	1.19	2.46	0.076	0.057

No measurements were made of the lateral stability with thrust. The contribution of the V-tailplane to  $\ell_v^*$  was

$\alpha^\circ$	Trimmed $C_L$	Measured	Estimated
2.05	0.11	-0.060	-0.063
7.6	0.535	-0.048	-0.052

Ref.3 was used for the estimate.

\*Values of  $\frac{C_n}{\beta}$  and  $\frac{C_\ell}{\beta}$  at  $\beta = 2\frac{1}{2}^\circ$  have been used for  $n_v$  and  $\ell_v$ .

5 Conclusions.

- (1) The modifications to the jet exit fillet increased its effectiveness in keeping the jet flow clear of the rear fuselage.
- (2) The estimates of the overall effect of the jets on the longitudinal stability are in fair agreement with the measured values.

The analysis of the jet effects without tailplane showed a discrepancy between the experimental results and an estimate which was made neglecting the interference between the jet and fuselage. Most of this discrepancy was found to be consistent with a downward force acting in the region of the duct exits. The estimate of the effect of the jet flow on the tailplane agreed reasonably with the experimental results.

REFERENCES

<u>No.</u>	<u>Author</u>	<u>Title, etc.</u>
1	H.B. Squire	Jet flow and its effects on aircraft R.A.E. Report No. Aero 2171, 1946 ARC 10,189
2	H.B. Squire and Miss J. Trouncer	Round jets in a general stream R and M 1974, 1944
3	I. Levacić	Rolling moment due to sideslip, Pt.I effect of dihedral, Pt.II - effect of sweepback and plan form, Pt.III - effect of wingbody arrangement and tail unit. R.A.E. Reports No. Aero 2028, 2092, 2139 1945-46 ARC Reports No. 8709, 9278, 9987

Attached:

Drawings 27872S to 27884S  
 Detachable Abstract Cards

Advance Distribution:

EDSR(A)	
ADARD(Res)	} Action copy
ADSR(Rec.)	
DGTD(A)	
TPA3/TIB	150
DARD	
DDARD	
EDRD(Aircraft)	
DMARD(RAF)	
DMARD(RN)	
ADRDL1	
ADRDL2	
ARDN	
DCARD	
A & AEE	
MAEE	
NPL(Aero Div)	3
RTO at Vickers Ltd	3
DRAE	
DDR AE(A)	
RAE Library	
NA Dept	
Aero(1)	
Aero T/A	
NAE Library	5
Aero E	
Aero F	
Aero H	
Aero P	
Aero Q	
Aero Sup	
Aero S	
Aero W	3

APPENDIX

Assumptions made in estimating the jet effects without tailplane

When the duct centre line at the intake is at an incidence to the free stream the change in flow direction of the air entering the duct produces forces  $N_1$  and  $F_1$  acting on the duct. ( $N_1$  is assumed to act in the plane of the entry).

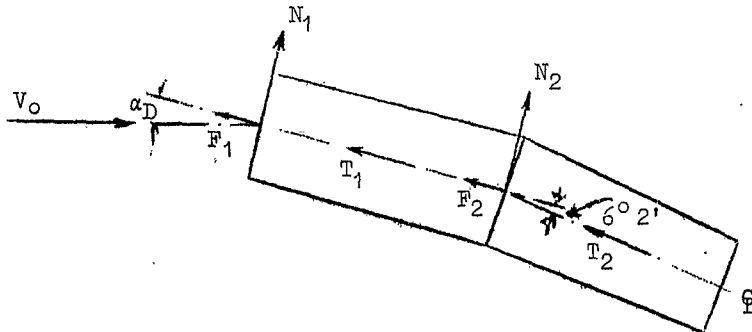

For the N 9/47 a second change in direction occurs at the kink in the duct giving forces  $N_2$  and  $F_2$ . The duct also carries the forces  $T_1$  and  $T_2$  arising from changes of momentum in the two parts of the duct. These six forces represent the overall forces on the duct. They can be evaluated by considering the changes of momentum at the intake, at the kink and in the ducts. For example:- at the intake

$$N_1 = G V_0 \sin \alpha_D$$

$$F_1 = G (V_1 - V_0 \cos \alpha_D)$$

where  $G$  is the mass flow  
 $V_0$  is the stream velocity  
 $V_1$  is the entry velocity  
 $\alpha_D$  is the angle of the duct centre line to the free stream.

A very close approximation to this system of forces is obtained by considering only  $N_1$ ,  $N_2$  and a thrust acting along the duct centre line at the exit. This approximation has been used in estimating the jet effects without tailplane and in calculating thrust lifts and moments.

For the N 9/47 geometry

$$(i) \frac{N_1}{\frac{1}{2} \rho V^2 S} = 0.0281 \frac{V_{exit}}{V_0} \sin \alpha_D$$

$$(ii) \frac{N_2}{\frac{1}{2} \rho V^2 S} = 0.00082 \left( \frac{V_{exit}}{V_0} \right)^2$$

$$(iii) \frac{Thrust}{\frac{1}{2} \rho V^2 S} = 0.0279 \frac{V_{exit}}{V_0} \left( \frac{V_{exit}}{V_0} - 1 \right)$$

The corresponding moments are

$$(i) \text{ due to } N_1 = 0.0388 \frac{V_{\text{exit}}}{V_0} \sin \alpha_D$$

$$(ii) \text{ due to } N_2 = 0.00026 \left( \frac{V_{\text{exit}}}{V_0} \right)^2$$

$$(iii) \text{ due to thrust} = 0.0191 \frac{V_{\text{exit}}}{V_0} \left( \frac{V_{\text{exit}}}{V_0} - 1 \right)$$

The estimates have all been made relative to the exit velocity ratio for zero thrust.  $\left( \frac{V_{\text{exit}}}{V_0} = 1.0 \right)$ .

---

TABLE I

## MODEL DATA

		Model Scale = 1/5	Full Scale
<u>WING</u>			
Area (projected)	S	13.37 sq ft	334.25 sq ft
Span	b	8.19 ft	40.95 ft
Mean chord	$\bar{c} = \frac{S}{b}$	1.63 ft	8.15 ft
Aspect ratio	A		5.01
Section (H.S.A.VII; N.P.L.No. 310)		Symmetrical 9% thick at 38% chord	
Root Chord (chord at wing and fuselage intersection)		2.05 ft	10.25 ft
Tip chord (obtained by producing L.E. and T.E. to extreme tip)		1.00 ft	5.00 ft
Sweepback	40% chord line is at rt. angles to the fuselage $\bar{c}$		
Dihedral			3°
Wing/fuselage angle			2°
Taper ratio (centre line chord/tip chord)			2.33
<u>TAILPLANE</u>			
Area (projected)	$S_T$	4.08 sq ft	102.1 sq ft
Span	$b_T$	3.44 ft	17.20 ft
Mean chord	$\bar{c}_T = \frac{S_T}{b_T}$	1.19 ft	5.95 ft
Aspect ratio	$A_T$		2.89
Section		Symmetrical 8% thick at 37% chord	
Height of $\bar{c}_T$ of tailplane above fuselage datum		0.15 ft	0.83 ft
Arm (Firms C.G. position to mean $\frac{1}{4}$ chord point of tail)	$l_T$	4.39 ft	21.95 ft
Volume coefficient	$\bar{v} = \frac{S_T l_T}{S \bar{c}}$		0.822
Sweepback	60% chord line is at rt. angles to the fuselage $\bar{c}$		
Dihedral			35°
Taper ratio (centre line chord/tip chord)			2.00
<u>DUCTS</u>			
Entry area (per side)		0.1192 sq ft	2.98 sq ft
Area at kink (per side)		0.338 sq ft	
Exit area (per side)		0.0939 sq ft	2.35 sq ft
Distance of entry ahead of C.G.		1.3825	1.3995
Distance of kink aft of C.G.		0.3145	0.2985
Distance of exit aft of C.G.		1.3305	1.3145
Perpendicular distance from C.G. of			
(i) Centre line of forward part of duct			0.03475
(ii) Centre line of rear part of duct (taken as thrust line)		0.06845	0.06745

NOTE: The areas and quarter chord points of the wing and tailplane are defined by producing leading and trailing edges to the fuselage and joining across fuselage.

TABLE I (Contd.)

Model Scale = 1/5 Full Scale

DUCTS (Contd.)

Direction of centre line of duct

Forward part	{	in vertical plane	parallel to fuselage datum
		in horizontal plane	2° 5' <u>in</u> , relative to centre line of aircraft
Rear part	{	in vertical plane	6° 2' <u>down</u> , relative to fuselage datum
		in horizontal plane	6° 40' <u>out</u> , relative to centre line of aircraft

C.G. POSITION

Ahead of wing 40% chord line	0.328 ft	1.64 ft
Above fuselage datum	0.018 ft	0.092 ft
Aft of L.E. of S.M.C.		0.1995

POSITION OF PITOT COMB

Aft of fuselage nose	7.8 ft	39.0 ft
----------------------	--------	---------

The positions A, B, C and D round the fuselage are shown in the figures.

TABLE II

Data used in applying model results with cold jets  
to full scale conditions  
 (Data obtained from firm)

- 1 Take off weight - 19,930 lb.
- 2 Thrust at sea level
 

Speed (m.p.h.)	150	200	300	400	600
Thrust per engine (lb)	5840	5720	5600	5450	5420
- 3 Thrust at 40,000 ft
 

Speed (m.p.h.)	200	300	400	600
Thrust per engine (lb)	1910	1870	1820	1810
- 4 Engine parameters for the Rolls Royce Avon.

Revs for maximum continuous conditions - 7,720 r.p.m. i.e. sustained maximum thrust.

$\frac{N}{\sqrt{T_T}}$	420	440	460	480	500	520	530
$\frac{M\sqrt{T_T}}{P_T}$	110	118	126	132.5	137	138	136.5

where N = engine revs.  
 $T_T$  = total absolute temperature at intake  
 M = mass flow lb/sec  
 $P_T$  = total pressure at intake lb/sq in.

- 5 Model Exit Velocity Ratios deduced from above data:-

$C_{L_{Trimmed}}$	Correct Mass Flow		Correct Exit Momentum	
	Sea Level	40,000 ft	Sea Level	40,000 ft
0.1	1.00	1.01	2.00	1.33
0.2	1.31	0.99	2.57	1.65
0.3	1.55	1.04	3.00	1.93
0.4	1.76	1.11	3.39	2.18
0.5	1.95	1.17	3.73	2.39
0.6	2.13	1.23	4.04	2.59

TABLE III

Trimmed Lift Coefficients

$V_o = 120 \text{ ft/sec}$ $R.N. = 1.23 \times 10^6$			$V_o = 80 \text{ ft/sec}$ $R.N. = 0.82 \times 10^6$		
Condition	$\alpha^\circ$	$C_{L_{Trimmed}}$	Condition	$\alpha^\circ$	$C_{L_{Trimmed}}$
$\frac{V_{exit}}{V_o} = 1.0$	-1.65	-0.174	$\frac{V_{exit}}{V_o} = 1.0$	0.45	-0.023
	0.5	-0.012		2.6	+0.140
	2.65	+0.155		4.75	0.309
	4.8	0.317		6.9	0.480
	6.95	0.491		9.0	0.639
	9.1	0.656			
	11.2	0.733			
13.2	0.761				
$\frac{V_{exit}}{V_o} = 2.25$	-1.65	-0.167	$\frac{V_{exit}}{V_o} = 3.4$	0.45	-0.013
	0.5	0		2.6	+0.157
	2.65	+0.168		4.75	0.337
	4.8	0.335		6.9	0.519
	6.95	0.506		9.1	0.698
	9.1	0.669			
	11.2	0.757			
13.25	0.816				

TABLE IV

Longitudinal Stability without Tailplanes

Condition	$\alpha^\circ$	$C_L$	$C_D$	$C_m$
$V_o = 120 \text{ ft/sec}$ $\frac{V_{exit}}{V_o} = 1.0$	-1.65	-0.161	0.0206	-0.0351
	+0.5	-0.006	0.0174	-0.0156
	2.65	+0.153	0.0202	+0.0062
	4.8	0.308	0.0263	0.0254
	6.95	0.474	0.0375	0.0449
	9.1	0.632	0.0593	0.0640
	11.2	0.727	0.1201	0.0172
13.2	0.769	0.1825	-0.0056	
$V_o = 120 \text{ ft/sec}$ $\frac{V_{exit}}{V_o} = 2.25$	-1.65	-0.154	-0.0520	-0.0348
	+0.5	+0.004	-0.0544	-0.0119
	2.65	0.165	-0.0515	+0.0093
	4.8	0.324	-0.0448	0.0295
	6.95	0.487	-0.0327	0.0497
	9.1	0.644	-0.0121	0.0687
	11.2	0.748	0.0513	0.0248
13.25	0.815	0.1094	0.0019	
$V_o = 80 \text{ ft/sec}$ $\frac{V_{exit}}{V_o} = 1.0$	0.45	-0.018	0.0183	-0.0144
	2.6	0.138	0.0200	+0.0060
	4.75	0.299	0.0252	0.0261
	6.9	0.464	0.0343	0.0441
	9.0	0.616	0.0542	0.0645
$V_o = 80 \text{ ft/sec}$ $\frac{V_{exit}}{V_o} = 3.4$	0.45	-0.005	-0.1918	-0.0213
	2.6	0.155	-0.1890	+0.0057
	4.75	0.326	-0.1834	0.0305
	6.9	0.501	-0.1726	0.0486
	9.1	0.672	-0.1529	0.0695

TABLE V  
Longitudinal Stability with Tailplane

Condition	$\eta_T^\circ$	$\alpha^\circ$	$C_L$	$C_D$	$C_m$
$V_o = 120 \text{ ft/sec}$ $\frac{V_{\text{exit}}}{V_o} = 1.0$	-1.95	-1.65	-0.223	0.0230	0.0696
		+0.5	-0.044	0.0188	0.0379
		2.65	+0.136	0.0206	0.0148
		4.8	0.318	0.0271	-0.0102
		6.95	0.506	0.0447	-0.0358
		9.1	0.681	0.0617	-0.0632
		11.2	0.784	0.1242	-0.1464
13.2	0.833	0.1908	-0.1924		
$V_o = 120 \text{ ft/sec}$ $\frac{V_{\text{exit}}}{V_o} = 2.25$	-1.95	-1.65	-0.210	-0.0484	0.0726
		+0.5	-0.033	-0.0525	0.0476
		2.65	+0.145	-0.0496	0.0248
		4.8	0.331	-0.0426	0.0026
		6.95	0.523	-0.0298	-0.0221
		9.1	0.694	-0.0074	-0.0428
		11.2	0.804	+0.0569	-0.1185
13.25	0.868	0.1280	-0.1638		
$V_o = 120 \text{ ft/sec}$ $\frac{V_{\text{exit}}}{V_o} = 1.0$	-3.95	-1.65	-0.248	0.0251	0.1476
		+0.5	-0.074	0.0201	0.1157
		2.65	+0.103	0.0211	0.0912
		4.8	0.279	0.0267	0.0679
		6.95	0.464	0.0379	0.0444
		9.1	0.643	0.0587	0.0188
		11.2	0.752	0.1225	-0.0700
13.2	0.810	0.1882	-0.1214		
$V_o = 120 \text{ ft/sec}$ $\frac{V_{\text{exit}}}{V_o} = 2.25$	-3.95	-1.65	-0.256	-0.0445	0.1526
		+0.5	-0.065	-0.0497	0.1266
		2.65	+0.114	-0.0487	0.1037
		4.8	0.293	-0.0420	0.0811
		6.95	0.478	-0.0306	0.0613
		9.1	0.663	-0.0083	0.0392
		11.2	0.768	+0.0531	-0.0458
13.65	0.857	0.1378	-0.1197		
$V_o = 80 \text{ ft/sec}$ $\frac{V_{\text{exit}}}{V_o} = 1.0$	-3.95	0.45	-0.070	0.0218	0.1168
		2.6	+0.103	0.0221	0.0896
		4.75	0.282	0.0277	0.0699
		6.9	0.468	0.0366	0.0484
		9.0	0.645	0.0586	0.0177
$V_o = 80 \text{ ft/sec}$ $\frac{V_{\text{exit}}}{V_o} = 3.4$	-3.95	0.45	-0.071	-0.1930	0.1371
		2.6	+0.109	-0.1875	0.1116
		4.75	0.295	-0.1838	0.0945
		6.9	0.494	-0.1728	0.0766
		9.1	0.671	-0.1551	0.0623

TABLE VI

Thrust Contribution to Lift and Pitching Moment

$V_{exit}/V_0 = 2.25$			$V_{exit}/V_0 = 3.4$		
$\alpha^\circ$	$\Delta C_L$	$\Delta C_m$	$\alpha^\circ$	$\Delta C_L$	$\Delta C_m$
-1.65	0.003	0.0054	0.45	0.018	0.0156
+0.5	0.006		2.6	0.026	
2.65	0.009		4.75	0.034	
4.8	0.012		6.9	0.043	
6.95	0.015		9.1	0.051	
9.1	0.018				
11.2	0.021				
13.25	0.023				

TABLE VII

Flow Contribution to lift and Pitching Moment without Tailplane  
Thrust Moment Removed

(Relative to  $V_{exit}/V_0 = 1.0$ )

$\Delta(V_{exit}/V_0)$	$\alpha^\circ$	$\Delta C_L$	$\Delta C_m$	$\Delta C_L$	$\Delta C_m$
				$\Delta(V_{exit}/V_0)$	$\Delta(V_{exit}/V_0)$
1.25	-1.65	0.004	0.0057	0.003	0.0046
	+0.5	0.004	0.0091	0.003	0.0073
	2.65	0.003	0.0085	0.002	0.0068
	4.8	0.004	0.0095	0.003	0.0076
	6.95	-0.002	0.0102	-0.002	0.0082
	9.1	-0.006	0.0101	-0.005	0.0081
	11.2	0	0.0130	0	0.0104
	13.25	+0.021	0.0133	+0.017	0.0106
2.4	0.45	-0.005	0.0087	-0.002	0.0036
	2.6	-0.009	0.0153	-0.004	0.0064
	4.75	-0.007	0.0200	-0.003	0.0083
	6.9	-0.006	0.0201	-0.003	0.0084
	9.1	-0.003	0.0201	-0.001	0.0084

TABLE VIII

Tailplane Contribution to Pitching Moment

(given relative to  $V_{exit}/V_0 = 1.0$ )

$V_{exit}/V_0 = 2.25$					$V_{exit}/V_0 = 3.4$		
$\alpha^\circ$	$\eta_T = -1.95^\circ$		$\eta_T = -3.95^\circ$		$\alpha^\circ$	$\eta_T = -3.95^\circ$	
	$\Delta C_m$	$\Delta C_m/Z^*$	$\Delta C_m$	$\Delta C_m/Z$		$\Delta C_m$	$\Delta C_m/Z$
-1.65	0.0027	0.0010	0.0047	0.0017	0.45	0.0272	0.0033
0.5	0.0060	0.0021	0.0072	0.0026			
2.65	0.0069	0.0025	0.0094	0.0033			
4.8	0.0087	0.0031	0.0091	0.0032			
6.95	0.0089	0.0032	0.0121	0.0043			
9.1	0.0157	0.0056	0.0157	0.0056			
11.2	0.0203	0.0072	0.0166	0.0059			
13.25	0.0221	0.0079					

where  $Z^* = \text{the momentum factor } \frac{V_{exit}}{V_0} \left( \frac{V_{exit}}{V_0} - 1 \right)$

TABLE IX

Experimental Results and Estimates of the Jet Effects on Lift and Pitching Moment for Maximum Steady Thrust at Sea Level and 40,000 ft

(All the effects are given relative to the values of  $C_L$  and  $C_m$  with  $\frac{V_{exit}}{V_0} = 1$ )

(a) Effects of the jets on  $C_L$  and  $C_m$  at constant incidence and tailsetting.

	Trimmed* $C_L$	From flow through ducts				From tailplane		From thrust	
		$\Delta C_L$		$\Delta C_m$		$\Delta C_m$		Exper. and Estimate	
		Exper.	Estimate	Exper.	Estimate	Exper.	Estimate	$\Delta C_L$	$\Delta C_m$
Sea Level	0.1	0	0	0	0	0.0046	0.0057	0.006	-0.0038
	0.2	-0.001	0.001	0.0020	0	0.0109	0.0135	0.014	-0.0077
	0.3	-0.001	0.002	0.0038	0.0004	0.0177	0.0209	0.024	-0.0115
	0.4	-0.002	0.003	0.0055	0.0011	0.0254	0.0281	0.037	-0.0155
	0.5		0.004		0.0019		0.0351	0.050	-0.0195
	0.6		0.006		0.0031		0.0424	0.067	-0.0235
40,000 ft	0.1	0	0	0	0	0.0008	0.0010	0.001	-0.0008
	0.2	0	0	0	0	0.0027	0.0037	0.004	-0.0020
	0.3	0	0	0.0003	0	0.0052	0.0071	0.007	-0.0034
	0.4	0	0	0.0008	0.0002	0.0086	0.0108	0.012	-0.0049
	0.5	0	0.001	0.0013	0.0004	0.0122	0.0145	0.017	-0.0063
	0.6	0	0.001	0.0019	0.0008	0.0167	0.0180	0.024	-0.0079

(b) Overall effect of the jet flow on  $C_m$  at various trimmed  $C_L$ 's

(including effects of change of incidence between  $\frac{V_{exit}}{V_0} = 1.0$  and with thrust)

Trimmed $C_L$	$\Delta C_m$			
	Sea Level		40,000 ft	
	Exper.	Estimate	Exper.	Estimate
0.1	0.0016	0.0027	0.0002	0.0004
0.2	0.0071	0.0079	0.0013	0.0023
0.3	0.0135	0.0137	0.0031	0.0047
0.4	0.0209	0.0197	0.0061	0.0079
0.5		0.0258	0.0098	0.0116
0.6		0.0335	0.0146	0.0149

\*The incidences considered are those corresponding to the trimmed  $C_L$  with thrust.

TABLE X

Directional Stability without Tailplane  
 (Original Jet Exit Fillet.  $V_0 = 120$  ft/sec)

Condition	$\alpha^\circ$	Trimmed $C_L$	$\beta^\circ$	$10^3 C_n$	$10^3 C_y$	$10^3 C_L$
$\frac{V_{exit}}{V_0} = 1.0$	2.05	0.105	0	0	0	
			5	-6.3	-11.2	
			10	-12.5	-24.3	
$\frac{V_{exit}}{V_0} = 2.25$	2.05		0	0	0	
			5	-7.1	-14.7	
			10	-13.5	-31.4	

TABLE XI

Lateral and Directional Stability without Tailplane  
 (Modified Jet Exit Fillet.  $V_0 = 120$  ft/sec)

Condition	$\alpha^\circ$	Trimmed $C_L$	$\beta^\circ$	$10^3 C_n$	$10^3 C_y$	$10^3 C_L$
$\frac{V_{exit}}{V_0} = 1.0$	2.05	0.11	0	0	0	0
			2.5	-3.4	-4.9	-0.5
			5	-6.8	-10.7	-1.1
			10	-12.7	-23.3	-2.3
$\frac{V_{exit}}{V_0} = 2.25$	2.05		0	0	0	
			2.5	-3.9	-6.9	
			5	-7.8	-13.2	
			10	-14.5	-29.3	
$\frac{V_{exit}}{V_0} = 1.0$	7.6	0.535	0	0	0	0
			2.5	-3.4	-4.7	-1.7
			5	-6.6	-10.6	-3.4
			10	-12.6	-24.0	-5.7
$\frac{V_{exit}}{V_0} = 2.25$	7.6		0	0	0	
			2.5	-4.0	-6.4	
			5	-7.7	-13.0	
			10	-14.4	-29.4	

# SECRET

Tech. Note No. Aero 2211

TABLE XII

Lateral and Directional Stability with Tailplane,  $\eta_T = -1.95^\circ$

(Modified Jet Exit Fillet.  $V_o = 120$  ft/sec)

Condition	$\alpha^\circ$	Trimmed $C_L$	$\beta^\circ$	$10^3 C_n$	$10^3 C_y$	$10^3 C_L$
$\frac{V_{exit}}{V_o} = 1.0$	2.05	0.11	0	0	0	0
			2.5	1.8	-15.4	-3.1
			5	4.2	-32.5	-5.9
			10	10.1	-68.0	-12.7
$\frac{V_{exit}}{V_o} = 2.25$	2.05		0	0	0	
			2.5	1.9	-19.5	
			5	4.4	-38.2	
			10	10.2	-78.2	
$\frac{V_{exit}}{V_o} = 1.0$	7.6	0.535	0	0	0	0
			2.5	2.5	-16.6	-3.8
			5	5.5	-34.3	-7.6
			10	11.7	-70.0	-16.2
$\frac{V_{exit}}{V_o} = 2.25$	7.6		0	0	0	
			2.5	2.8	-19.8	
			5	5.5	-38.0	
			10	11.4	-79.3	

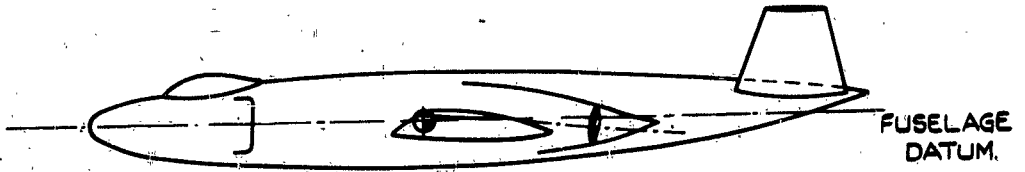

DRAWING SHOWS THE 1<sup>ST</sup> MODIFICATION TO THE JET EXIT FILLET.

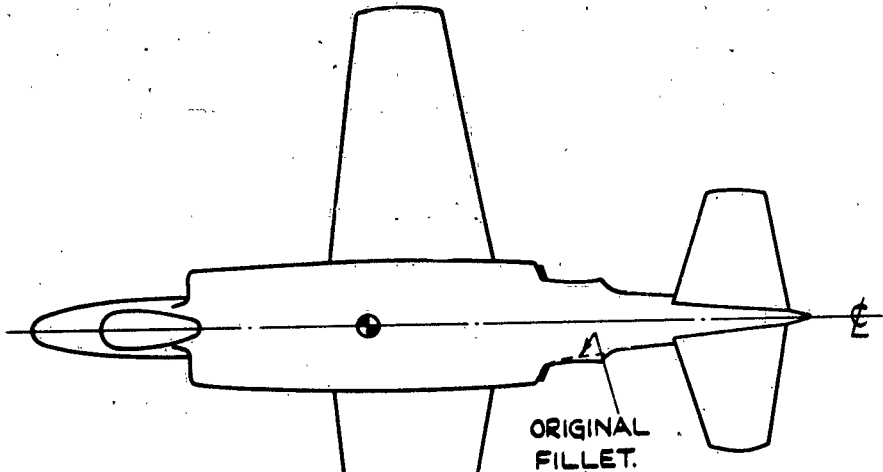

FT. FULL SCALE  
0 5 10  
0 1 2  
FT. MODEL SCALE.

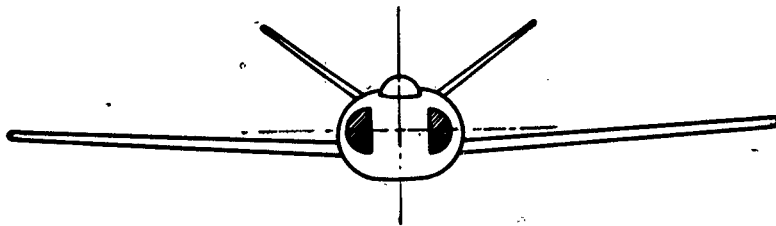
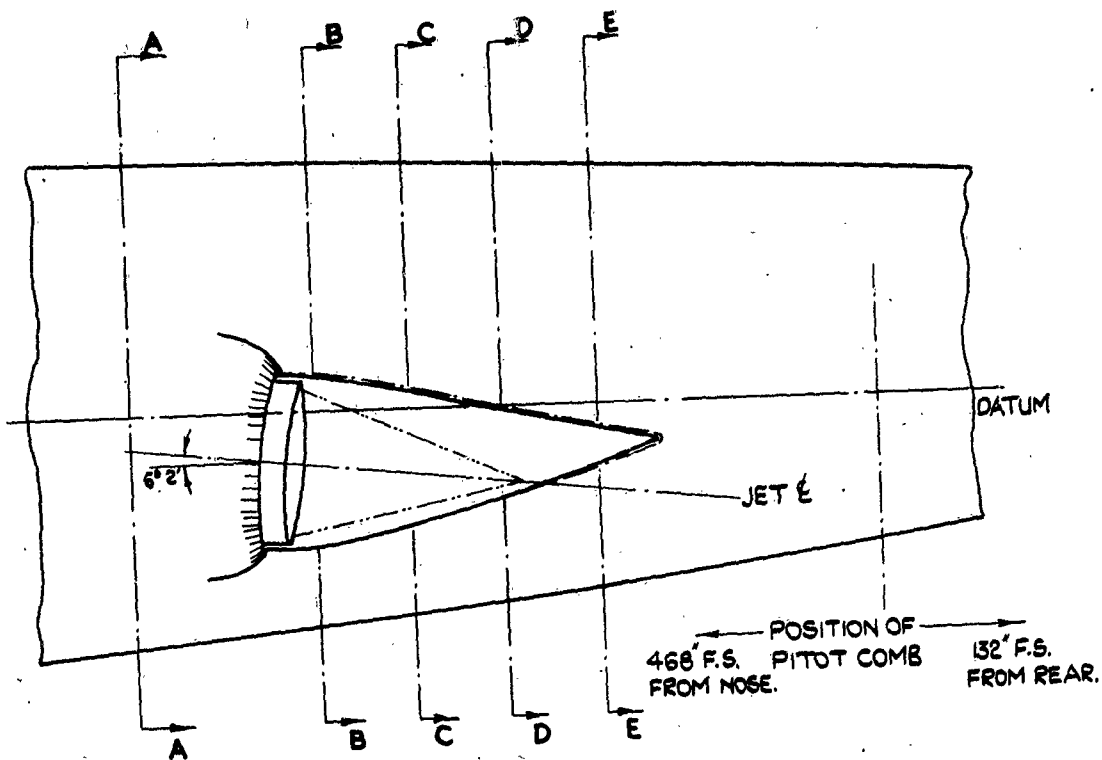

FIG. 1. G. A. OF MODEL



----- ORIGINAL  
----- 1ST. MODIFICATION.  
----- 2ND. MODIFICATION

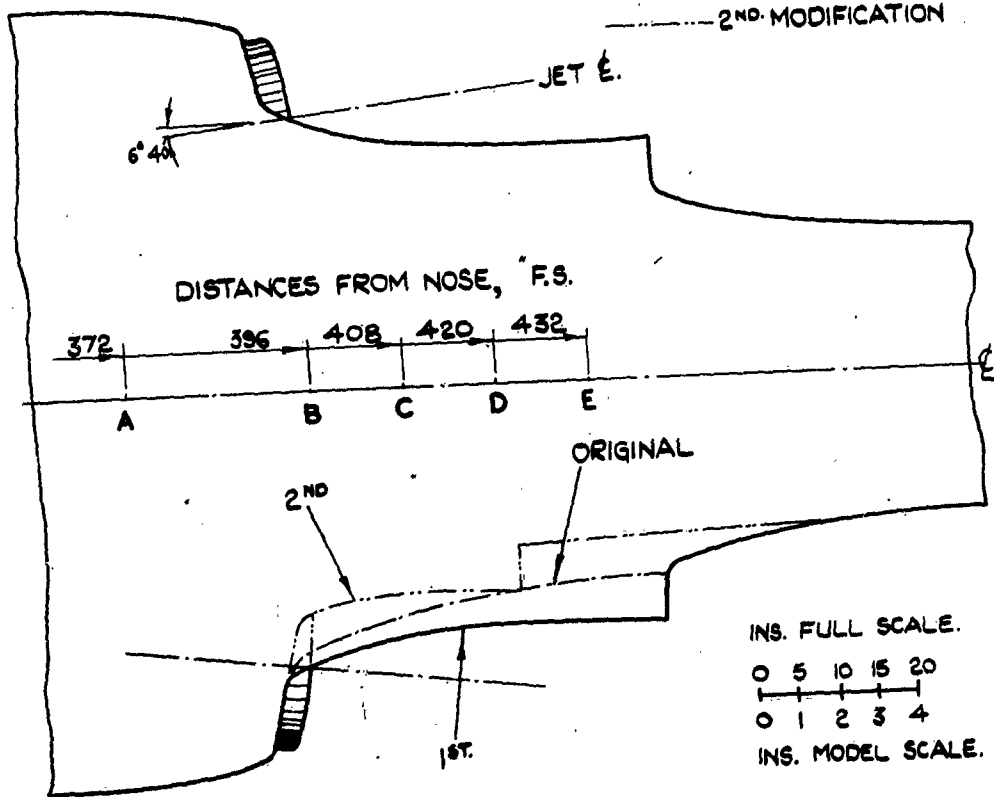
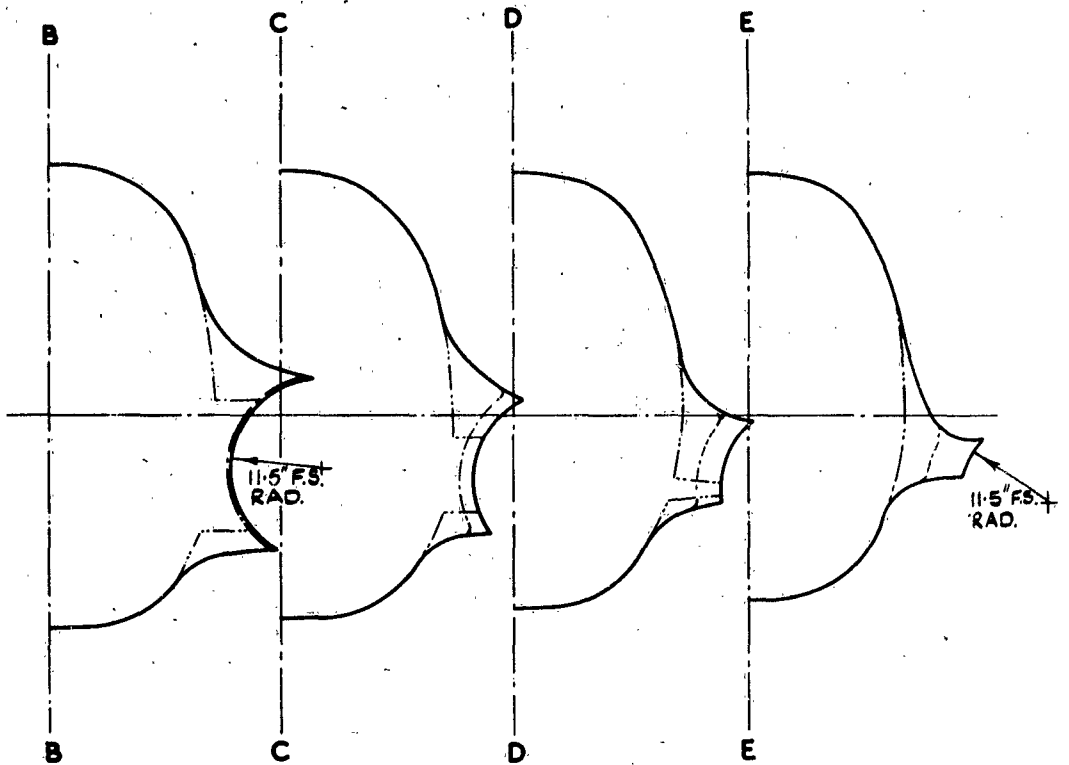
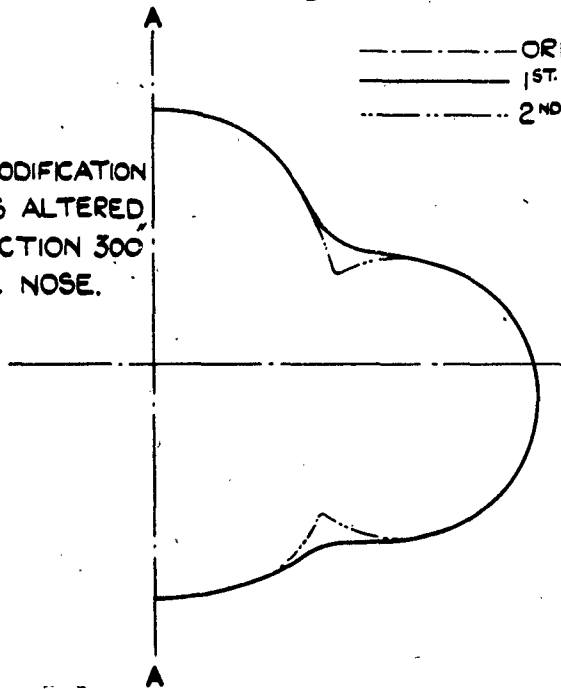

FIG.2. JET. EXIT FILLETS, SIDE & PLAN VIEWS.



- - - - - ORIGINAL  
 ——— 1<sup>ST</sup>. MODIFICATION  
 - · - · - 2<sup>ND</sup>. MODIFICATION.

FOR THE 2<sup>ND</sup> MODIFICATION  
 THE BODY WAS ALTERED  
 AFT OF A SECTION 300'  
 F.S. FROM THE NOSE.



INS. FULL SCALE  
 0 5 10 15 20  
 ———  
 0 1 2 3 4  
 INS. MODEL SCALE.

FIG. 3. JET EXIT FILLETS, CROSS SECTIONS

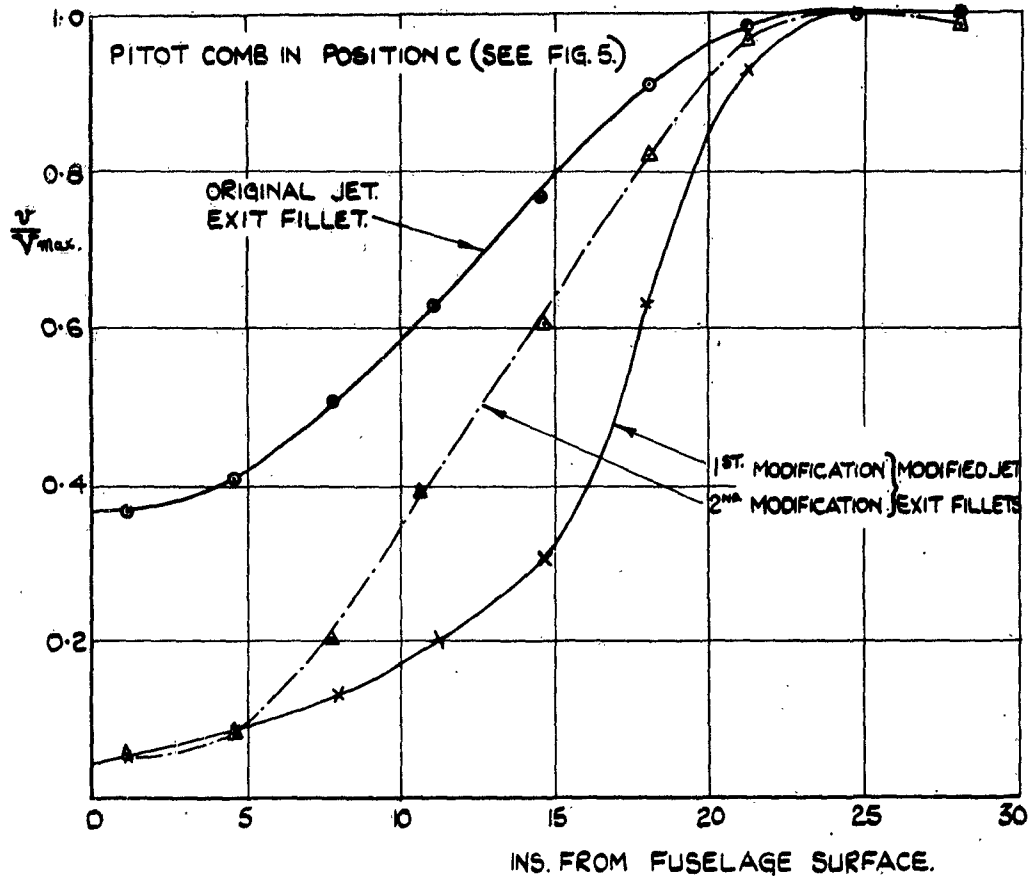
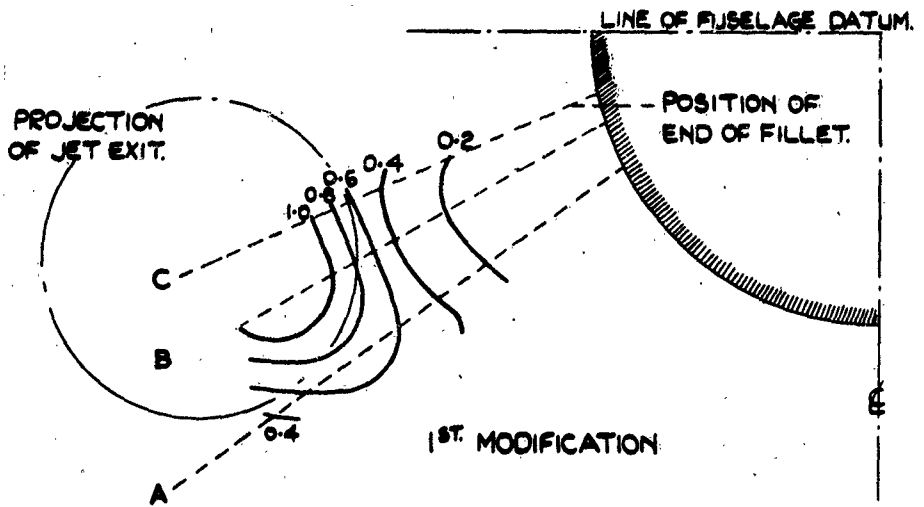

FIG. 4. VELOCITY TRAVERSE BEHIND THE ORIGINAL & MODIFIED JET EXIT FILLETS AT ZERO TUNNEL SPEED, EXIT VELOCITY - 210 FT/SEC.



INS. FULL SCALE  
 0 5 10  
 0 1 2  
 INS. MODEL SCALE.

NUMBERS ON FIGURE GIVE LOCAL VELOCITY AS A FRACTION OF MAX. VELOCITY.

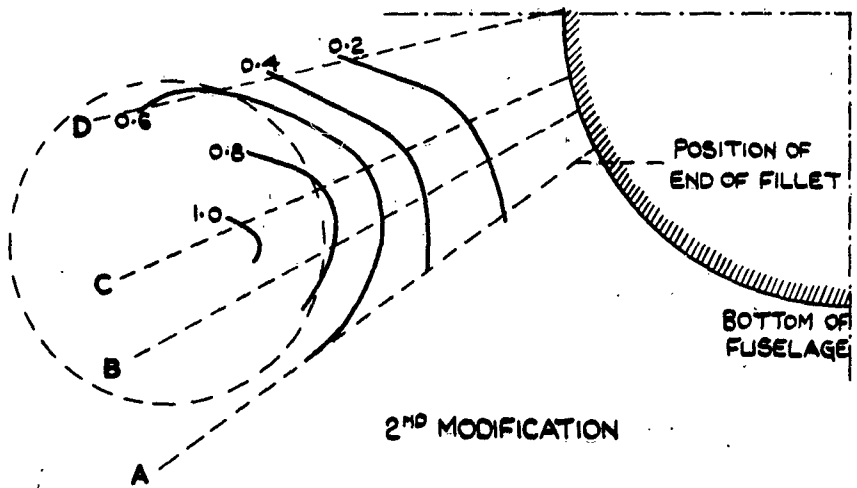
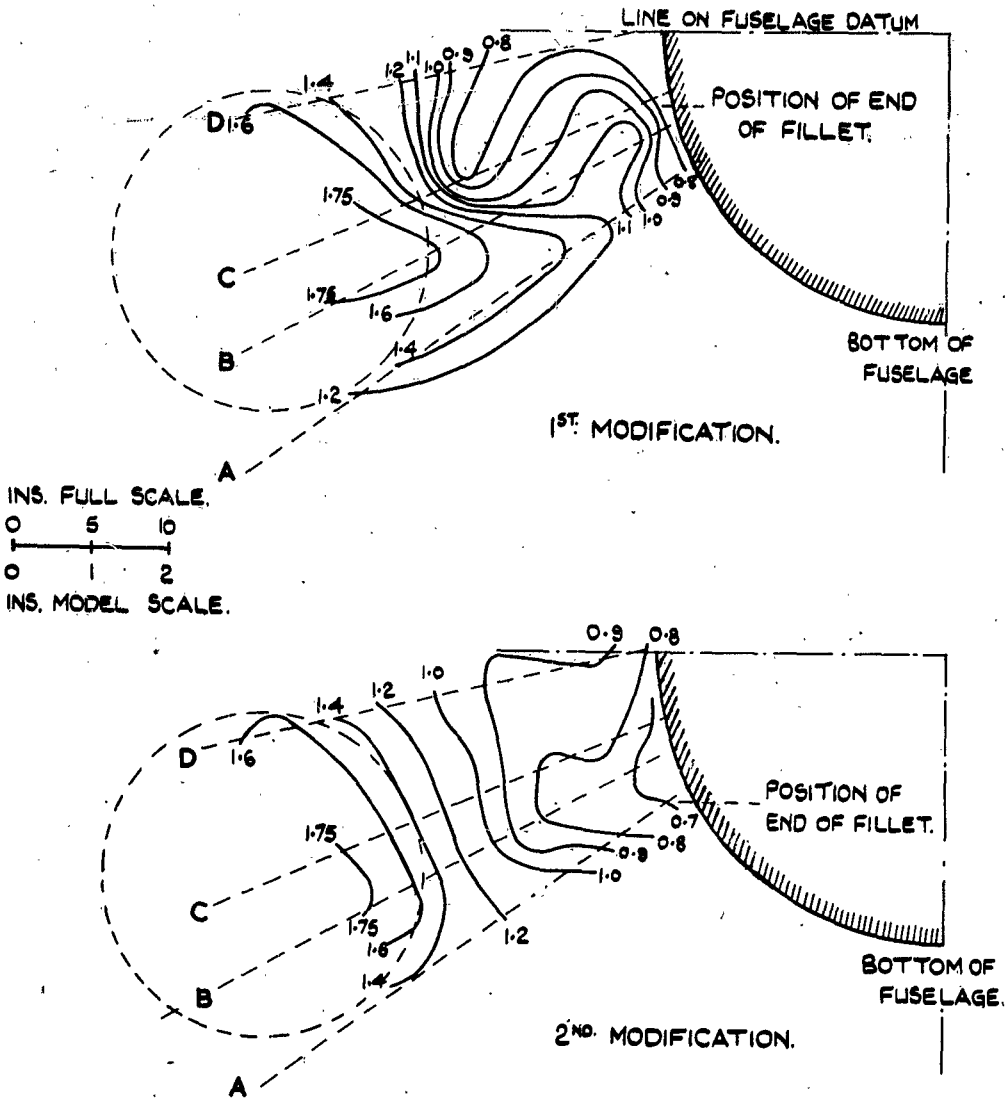

FIG. 5. VELOCITY DISTRIBUTION BEHIND THE MODIFIED JET EXIT FILLETS AT ZERO TUNNEL SPEED - EXIT VELOCITY - 210 FT/SEC.



NUMBERS ON FIGURE GIVE LOCAL VELOCITY AS A FRACTION OF FREE STREAM VELOCITY.

INCIDENCE OF BODY DATUM =  $0.05^\circ$   
 JET IS  $6^\circ 40'$  OUT } RELATIVE TO  
 $6^\circ 2'$  DOWN } THE BODY DATUM.

**FIG. 6. VELOCITY DISTRIBUTION BEHIND THE MODIFIED JET EXIT FILLETS.**

$V_0 = 120 \text{ FT/SEC.}$      $\frac{V_{exit}}{V_0} = 1.75$      $\alpha = 2.05^\circ$      $C_L(\text{TRIMMED}) = 0.11.$   
 $\beta = 0^\circ$

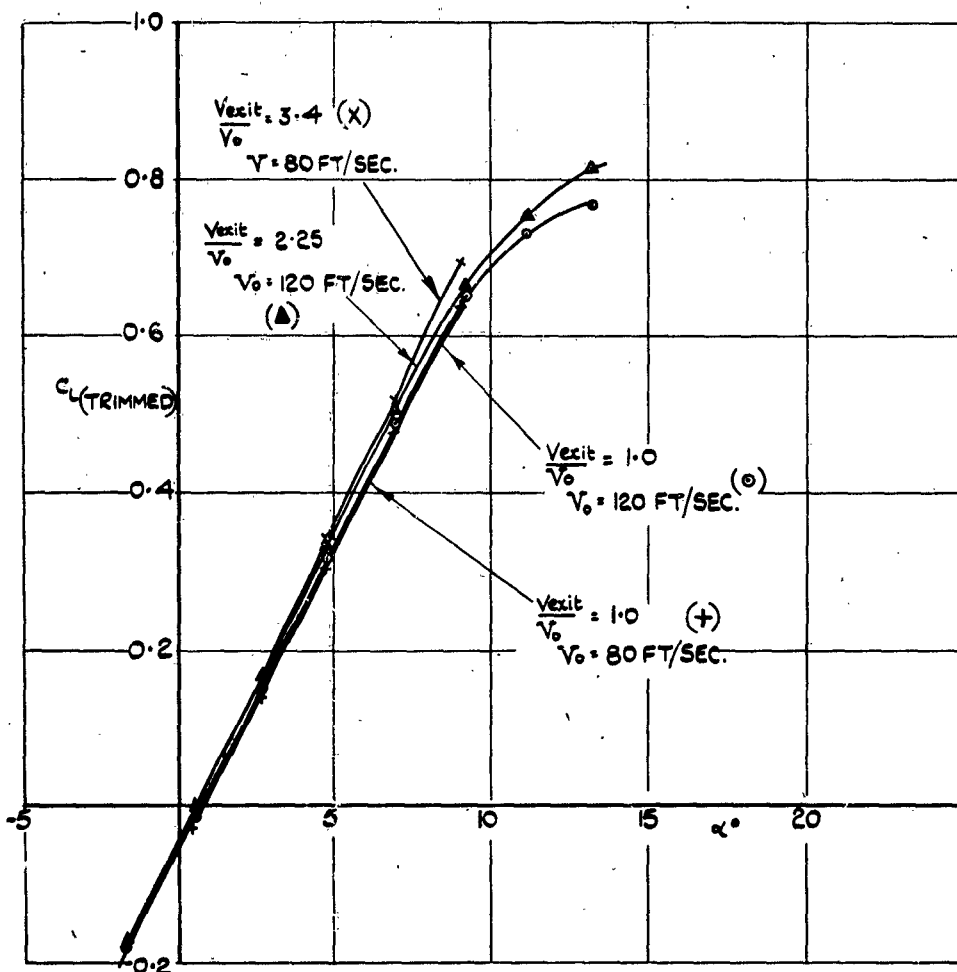
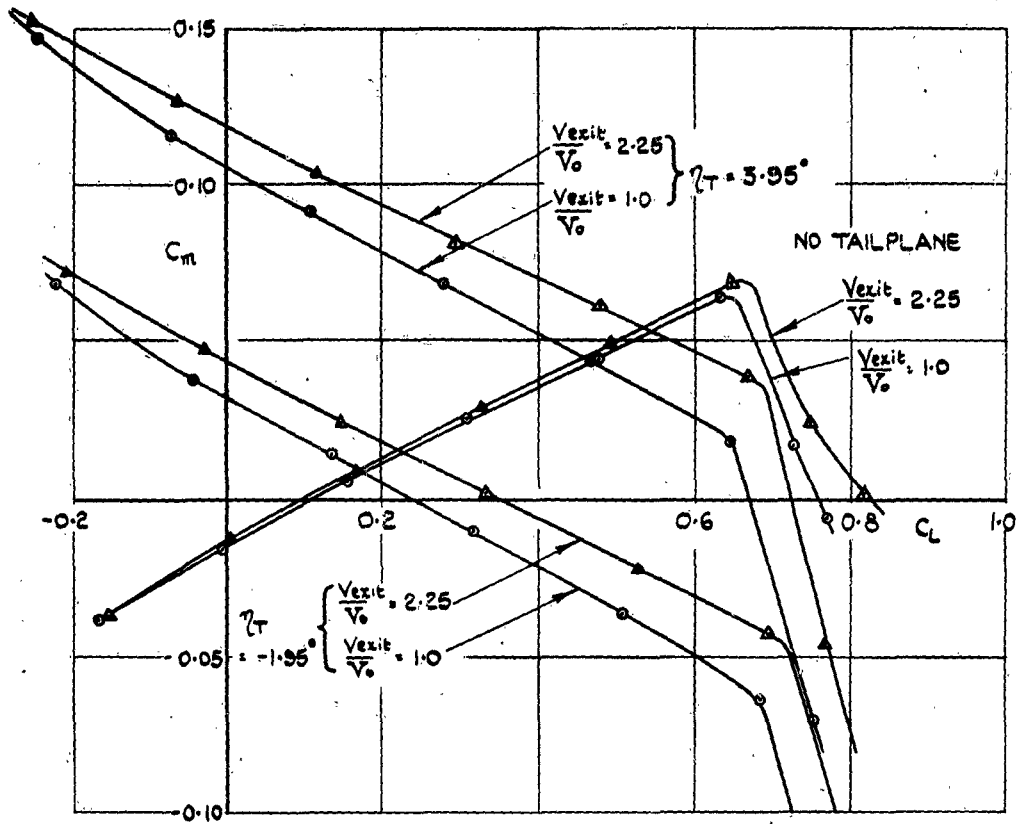
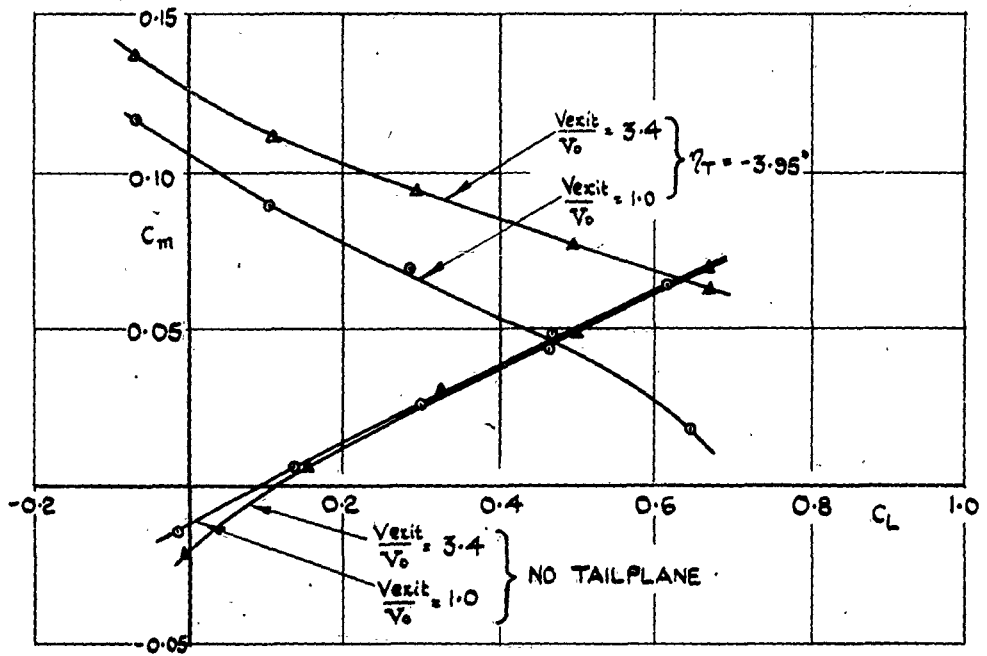

FIG. 7. TRIMMED LIFT COEFFICIENTS.

FIG. 8.



$V_0 = 120 \text{ FT/SEC}$   $R.N. = 1.23 \times 10^6$



$V_0 = 80 \text{ FT/SEC}$   $R.N. = 0.82 \times 10^6$

FIG. 8. PITCHING MOMENT COEFFICIENTS.

$\tau_T$

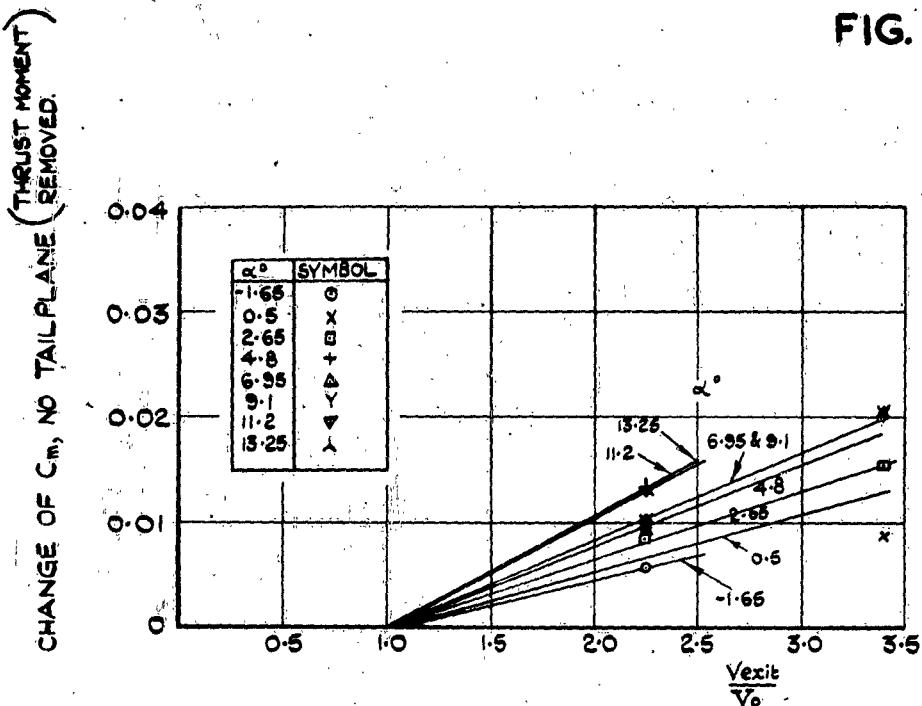

FIG. 9. EFFECT OF FLOW ON PITCHING MOMENT OF MODEL WITHOUT TAILPLANE.  
(PITCHING MOMENTS ARE GIVEN RELATIVE TO  $\frac{V_{exit}}{V_0} = 1.0$ )

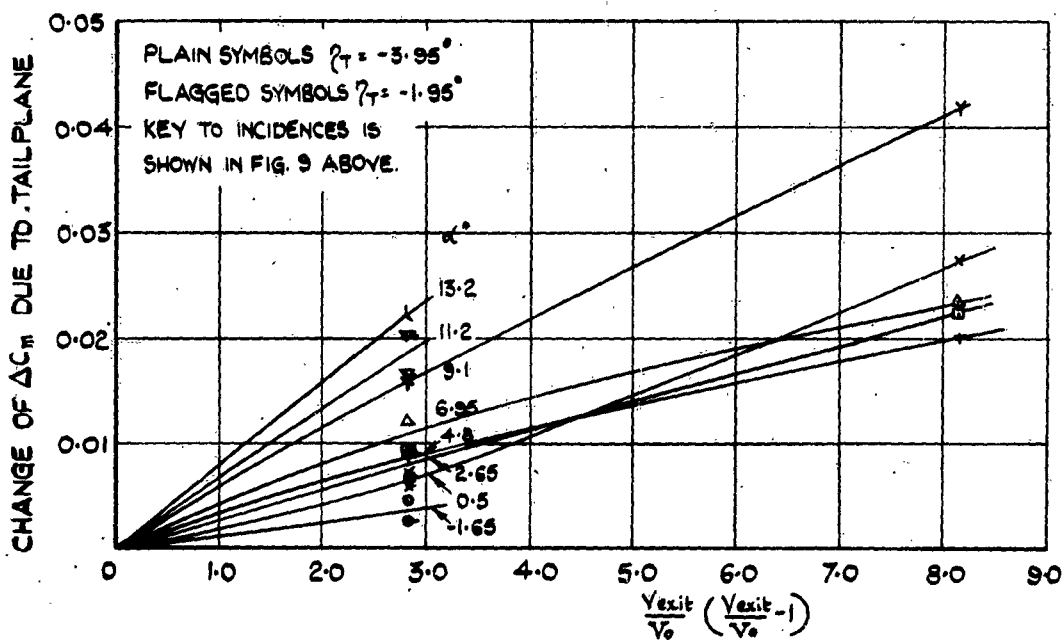

FIG. 10. EFFECT OF FLOW ON TAILPLANE CONTRIBUTION TO PITCHING MOMENT  
(PITCHING MOMENTS ARE GIVEN RELATIVE TO  $\frac{V_{exit}}{V_0} = 1.0$ )

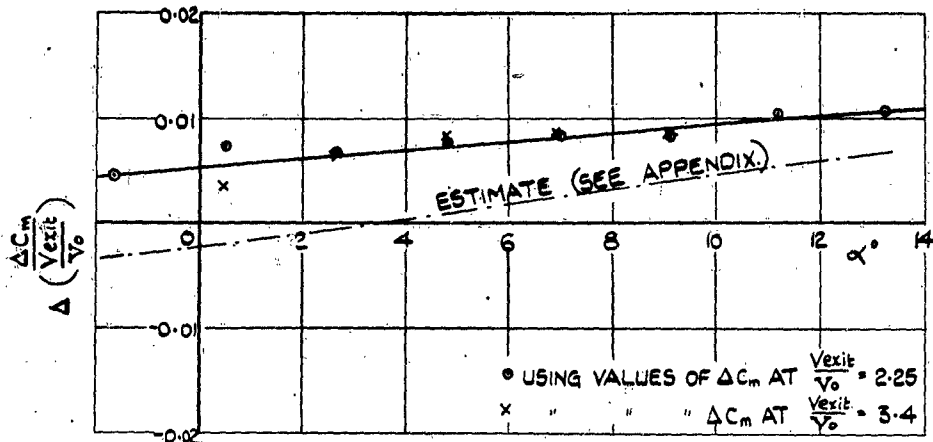

FIG. II. EFFECT OF INCIDENCE ON THE CHANGE IN  $C_m$  DUE TO FLOW, NO TAILPLANE.

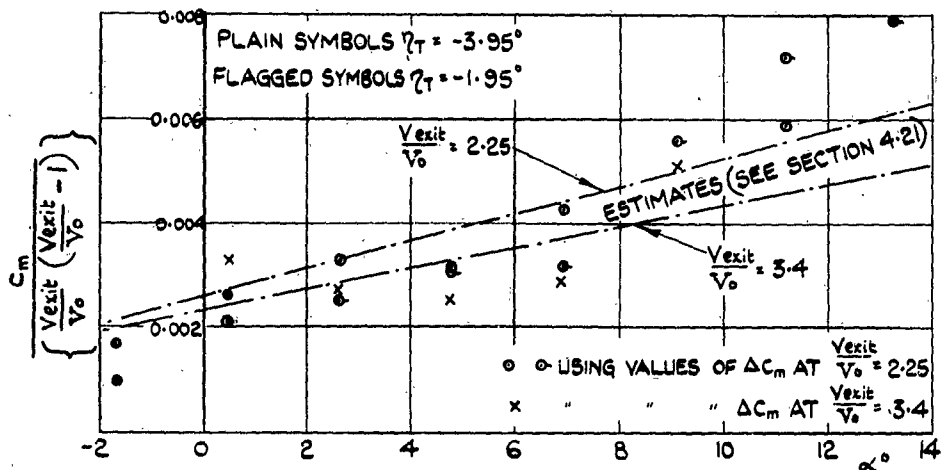

FIG. 12. EFFECT OF INCIDENCE ON THE CHANGE IN  $\Delta C_m$  TAILPLANE DUE TO FLOW.

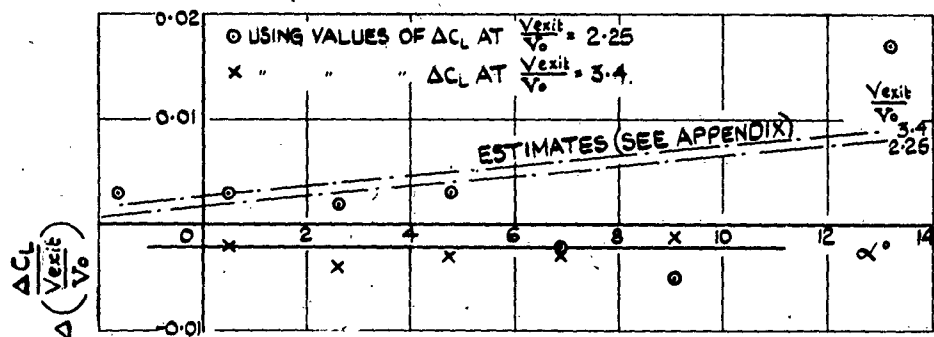

FIG. 13. EFFECT OF INCIDENCE ON THE CHANGE IN  $\Delta C_L$  DUE TO FLOW, NO TAILPLANE.

FT  
L

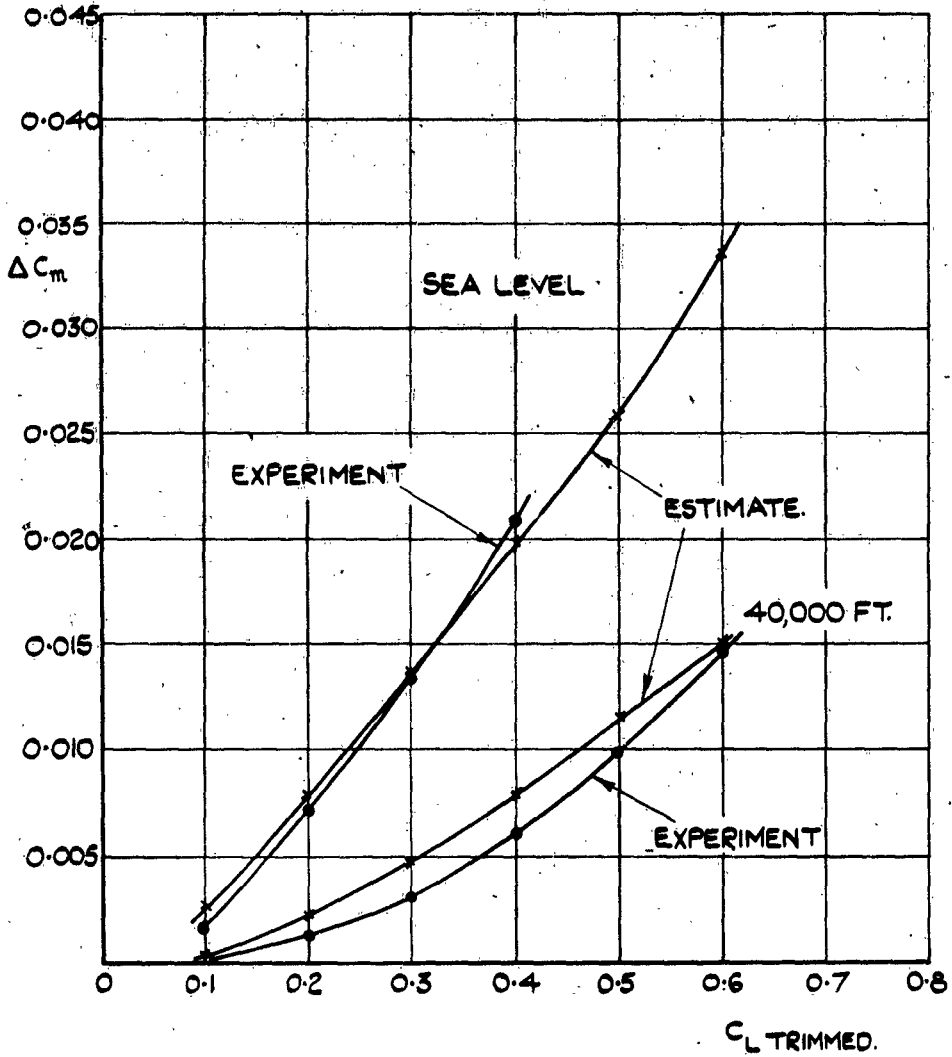

FIG. 14. OVERALL EFFECT OF JET FLOW ON PITCHING MOMENT GIVEN RELATIVE TO  $\frac{V_{exit}}{V_0} = 1.0$

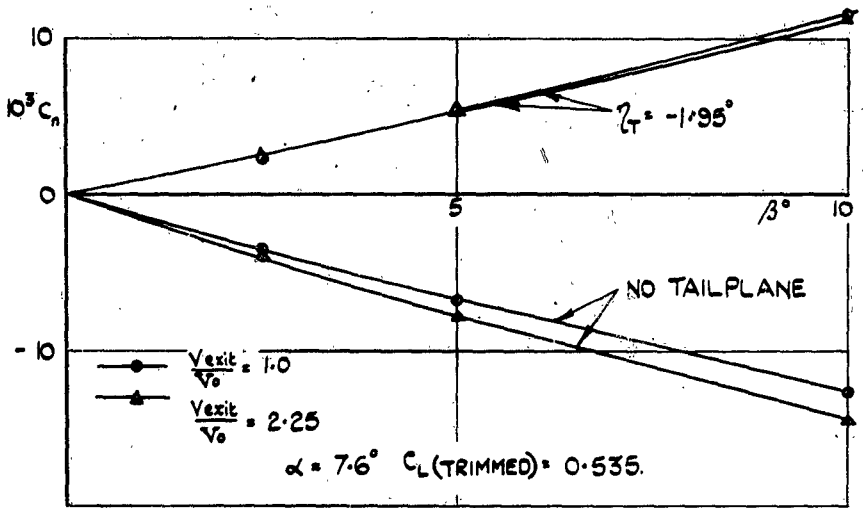
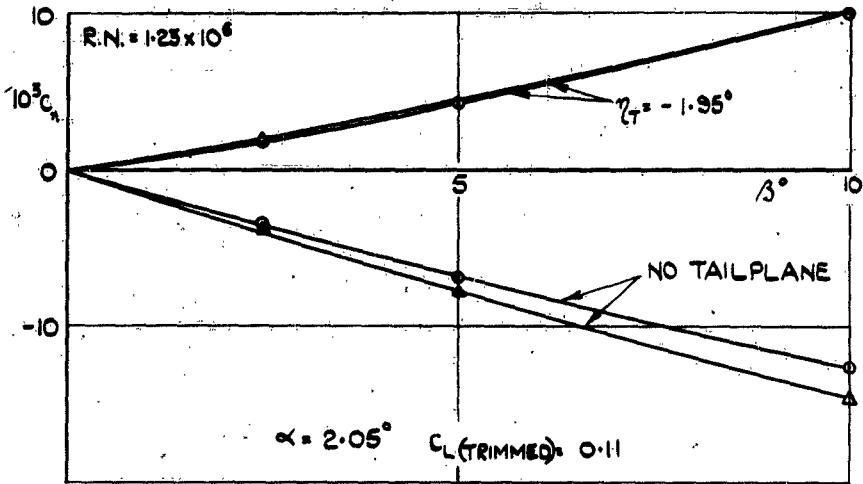

FIG. 15. YAWING MOMENT COEFFICIENTS.

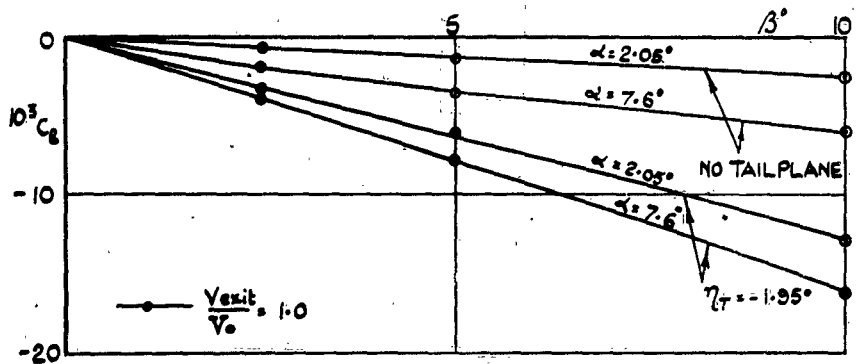

FIG. 16. ROLLING MOMENT COEFFICIENTS.

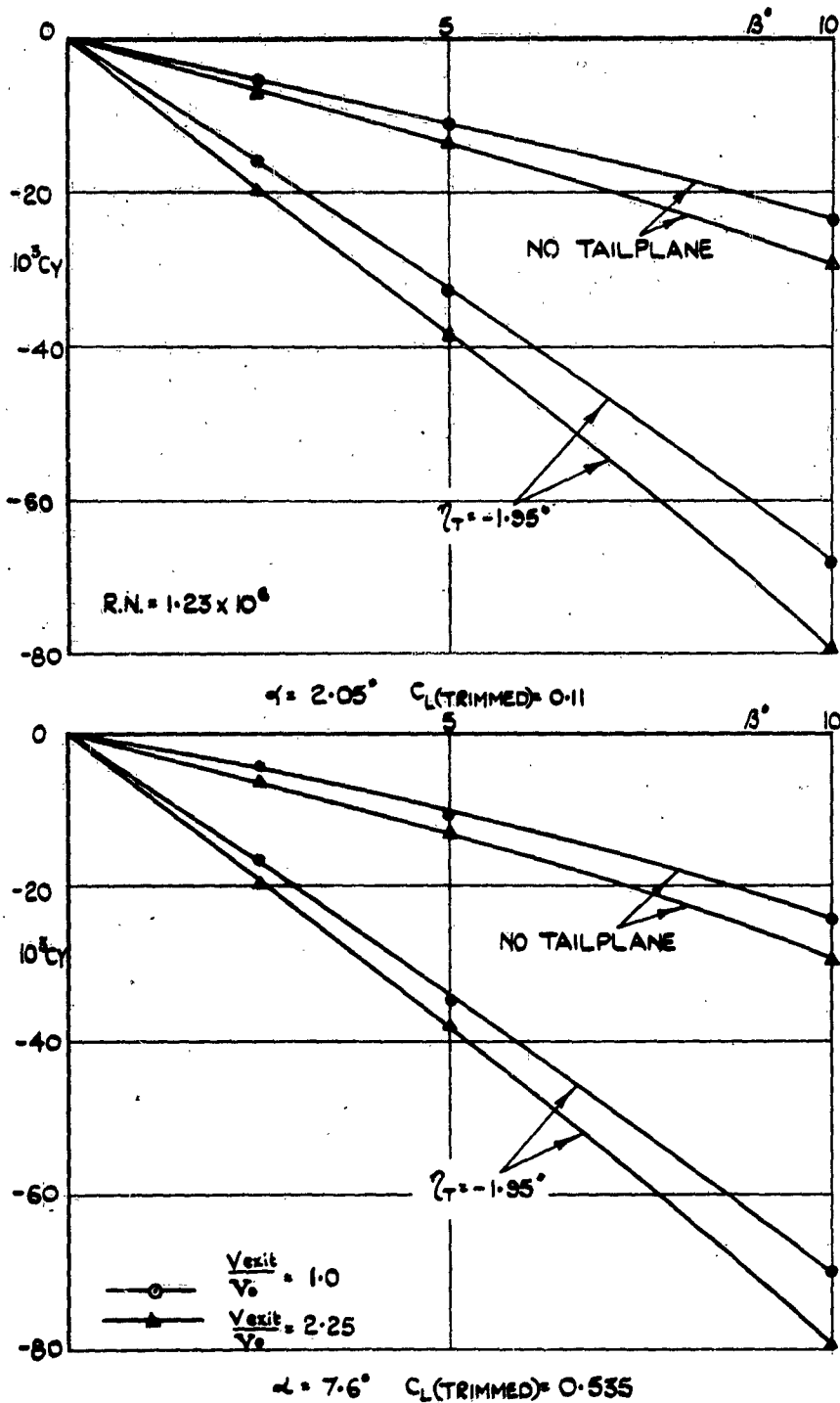

FIG. 17. SIDEFORCE COEFFICIENTS

DETACHABLE ABSTRACT CARDS

These abstract cards are inserted in RAE Reports and Technical Notes for the convenience of Librarians and others who need to maintain an Information Index.

Detached cards are subject to the same Security Regulations as the parent document, and a record of their location should be made on the inside of the back cover of the parent document.

<p align="center">RESTRICTED</p> <p>Royal Aircraft Est. Technical Note Aero.2211 1952.11 Kirby, D.A.</p> <p>533.652.1.011.3(42) Supermarine N9/47: 533.695.75: 533.69.048.2: 533.6.013.412/415: 533.6.013.13/152</p> <p>LOW SPEED TUNNEL TESTS WITH JET FLOW REPRESENTED ON A 1/5TH SCALE MODEL OF A TWIN JET FIGHTER WITH AN UNSWEPT WING AND V-TAILPLANE (SUPERMARINE N9/47)</p> <p>Low speed tunnel tests have been made on the Supermarine N9/47 to check the effects of the jet flow on the longitudinal stability and to test the V-tailplane. Measurements of the velocity distribution behind the exit have been made to check the effectiveness of the jet exit fillet in keeping the jet flow clear of the rear fuselage.</p> <p align="right">P.T.O.</p>	<p align="center">RESTRICTED</p> <p>Royal Aircraft Est. Technical Note Aero.2211 1952.11 Kirby, D.A.</p> <p>533.652.1.011.3(42) Supermarine N9/47: 533.695.75: 533.69.048.2: 533.6.013.412/415: 533.6.013.13/152</p> <p>LOW SPEED TUNNEL TESTS WITH JET FLOW REPRESENTED ON A 1/5TH SCALE MODEL OF A TWIN JET FIGHTER WITH AN UNSWEPT WING AND V-TAILPLANE (SUPERMARINE N9/47)</p> <p>Low speed tunnel tests have been made on the Supermarine N9/47 to check the effects of the jet flow on the longitudinal stability and to test the V-tailplane. Measurements of the velocity distribution behind the exit have been made to check the effectiveness of the jet exit fillet in keeping the jet flow clear of the rear fuselage.</p> <p align="right">P.T.O.</p>
<p align="center">RESTRICTED</p> <p>Royal Aircraft Est. Technical Note Aero.2211 1952.11 Kirby, D.A.</p> <p>533.652.1.011.3(42) Supermarine N9/47: 533.695.75: 533.69.048.2: 533.6.013.412/415: 533.6.013.13/152</p> <p>LOW SPEED TUNNEL TESTS WITH JET FLOW REPRESENTED ON A 1/5TH SCALE MODEL OF A TWIN JET FIGHTER WITH AN UNSWEPT WING AND V-TAILPLANE (SUPERMARINE N9/47)</p> <p>Low speed tunnel tests have been made on the Supermarine N9/47 to check the effects of the jet flow on the longitudinal stability and to test the V-tailplane. Measurements of the velocity distribution behind the exit have been made to check the effectiveness of the jet exit fillet in keeping the jet flow clear of the rear fuselage.</p> <p align="right">P.T.O.</p>	<p align="center">RESTRICTED</p> <p>Royal Aircraft Est. Technical Note Aero.2211 1952.11 Kirby, D.A.</p> <p>533.652.1.011.3(42) Supermarine N9/47: 533.695.75: 533.69.048.2: 533.6.013.412/415: 533.6.013.13/152</p> <p>LOW SPEED TUNNEL TESTS WITH JET FLOW REPRESENTED ON A 1/5TH SCALE MODEL OF A TWIN JET FIGHTER WITH AN UNSWEPT WING AND V-TAILPLANE (SUPERMARINE N9/47)</p> <p>Low speed tunnel tests have been made on the Supermarine N9/47 to check the effects of the jet flow on the longitudinal stability and to test the V-tailplane. Measurements of the velocity distribution behind the exit have been made to check the effectiveness of the jet exit fillet in keeping the jet flow clear of the rear fuselage.</p> <p align="right">P.T.O.</p>

RESTRICTED

Estimation of the reduction in static stability margin using the results of previous work (Meteor and Vampire) gave fair agreement with the measured reduction. Modifications to the jet exit fillet were tested and found to increase its effectiveness.

RESTRICTED

RESTRICTED

Estimation of the reduction in static stability margin using the results of previous work (Meteor and Vampire) gave fair agreement with the measured reduction. Modifications to the jet exit fillet were tested and found to increase its effectiveness.

RESTRICTED

RESTRICTED

Estimation of the reduction in static stability margin using the results of previous work (Meteor and Vampire) gave fair agreement with the measured reduction. Modifications to the jet exit fillet were tested and found to increase its effectiveness.

RESTRICTED

RESTRICTED

Estimation of the reduction in static stability margin using the results of previous work (Meteor and Vampire) gave fair agreement with the measured reduction. Modifications to the jet exit fillet were tested and found to increase its effectiveness.

RESTRICTED



*Information Centre  
Knowledge Services*  
**[dstl]** Porton Down  
Salisbury  
Wiltshire  
SP4 0JQ  
22060-6218  
Tel: 01980-613753  
Fax: 01980-613970

Defense Technical Information Center (DTIC)  
8725 John J. Kingman Road, Suit 0944  
Fort Belvoir, VA 22060-6218  
U.S.A.

AD#: AD008142

Date of Search: 12 February 2009

Record Summary: AVIA 6/23497

Low speed tunnel tests with jet flow represented on 1/5 scale model of twin jet fighter with unswept wing and V-tailplane (supermarine)  
Former reference (Department): Technical Note No Aero2211  
Held by The National Archives, Kew

This document is now available at the National Archives, Kew, Surrey, United Kingdom.

DTIC has checked the National Archives Catalogue website (<http://www.nationalarchives.gov.uk>) and found the document is available and releasable to the public.

Access to UK public records is governed by statute, namely the Public Records Act, 1958, and the Public Records Act, 1967.  
The document has been released under the 30 year rule.  
(The vast majority of records selected for permanent preservation are made available to the public when they are 30 years old. This is commonly referred to as the 30 year rule and was established by the Public Records Act of 1967).

This document may be treated as **UNLIMITED**.