

UNCLASSIFIED

AD _____

DEFENSE DOCUMENTATION CENTER

FOR

SCIENTIFIC AND TECHNICAL INFORMATION

CAMERON STATION ALEXANDRIA, VIRGINIA

DOWNGRADED AT 3 YEAR INTERVALS:
DECLASSIFIED AFTER 12 YEARS
DCD DIR 5200.10



UNCLASSIFIED

THIS REPORT HAS BEEN DECLASSIFIED
AND CLEARED FOR PUBLIC RELEASE.

DISTRIBUTION A
APPROVED FOR PUBLIC RELEASE;
DISTRIBUTION UNLIMITED.

AD NO. 9368
ASTIA FILE COPY

WOODS HOLE OCEANOGRAPHIC INSTITUTION

WOODS HOLE, MASSACHUSETTS

WOODS HOLE OCEANOGRAPHIC INSTITUTION

WOODS HOLE, MASSACHUSETTS

Reference No. 52-88

On the Nature of Estuarine
Circulation

PART I
(Chapters 3 and 4)

by

Henry Stommel
Harlow G. Farmer

Technical Report
submitted to the Office of Naval Research
under Contract No. N6onr-27701 (NR-083-004).

October, 1952

APPROVED FOR DISTRIBUTION

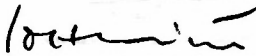

Director.

Preface to Chapters 3 and 4

Chapters 3 and 4 complete Part I of this report.

We would like to call attention to the fact that the informal nature of these unpublished Technical Reports invites an amount of speculation which would be perhaps intolerable in the published literature, and a certain looseness and crudeness in derivations and formulations of problems which a regular published work would not exhibit. It seems desirable to the authors to make a statement at this point concerning the scope of what we know and what we do not know in the subject matter of these two chapters.

The reader will quickly see that the subject matter of Chapter 3 is confined to the hydraulics of sharply stratified media, whereas real estuaries are always more or less diffusely stratified. What is more, no discussion is made of the order of magnitude of the friction terms. In ordinary single layer flow (such as in rivers) engineers already have crude approximations of the friction terms (Chezy and Manning formulas), but we do not have even these approximations for two layer flow. For this reason the differential equations of gradually varied flow of two layers are for the most part left unintegrated and all that is demonstrated is the qualitative aspects of the flow.

In the case of entrainment of water from one layer into another we can only perform integrations of the equations when the amount of entrainment is known, whereas in real estu-

aries we do not have a priori knowledge of this amount. The reader will see, therefore, that the subject matter of Chapter 3 is really very incomplete, leaving undetermined all the constants which depend upon turbulent mixing, upon the frictional stresses on the bottom, and the free surface and the walls, and upon the amount of entrainment.

The contents of Chapter 4 are somewhat different. First of all, they contain summaries of several already published papers on the mixing in estuaries. Most of these papers have proceeded on the basis of hypotheses about the nature of the mixing process. The applicability of these hypotheses appears to be restricted to only certain estuaries, and it must be admitted that more work has been done that involves guessing what the mixing processes in an estuary might be, than has been done in trying to find out what the mixing processes in an estuary actually are.

As incomplete as the subject matter of Chapter 4 is, it is hoped that it will suggest which of the possible mixing processes in estuaries may be important in any particular one which is the subject of study, and that it will also suggest the type of observations which will be most desirable in studying a particular estuary. For example: in an unstratified estuary it seems that a more or less uniform spacing of stations up and down the estuary is de-

irable; but in an estuary which appears to be subject to the constraint of overmixing (Section 4.51) the location of stations should be largely confined to control sections.

CHAPTER 3.

Gradually varied flow.

3.1 The general equation of varied flow.

We envisage a channel whose axis is oriented along the x axis, whose width is $b(x)$. The z axis is directed vertically upward. The y -axis is directed horizontally across the channel.

Two layers of vertically homogeneous liquids flow in this channel, the lighter on top of the heavier. The upper liquid, whose density is $\rho_1(x)$, has a free surface at $z = \zeta_1(x)$.

The interface between this upper fluid and the lower liquid layer, whose density is $\rho_2(x)$, is at $z = \zeta_2(x)$. The bottom of the channel is at $z = \zeta_3(x)$.

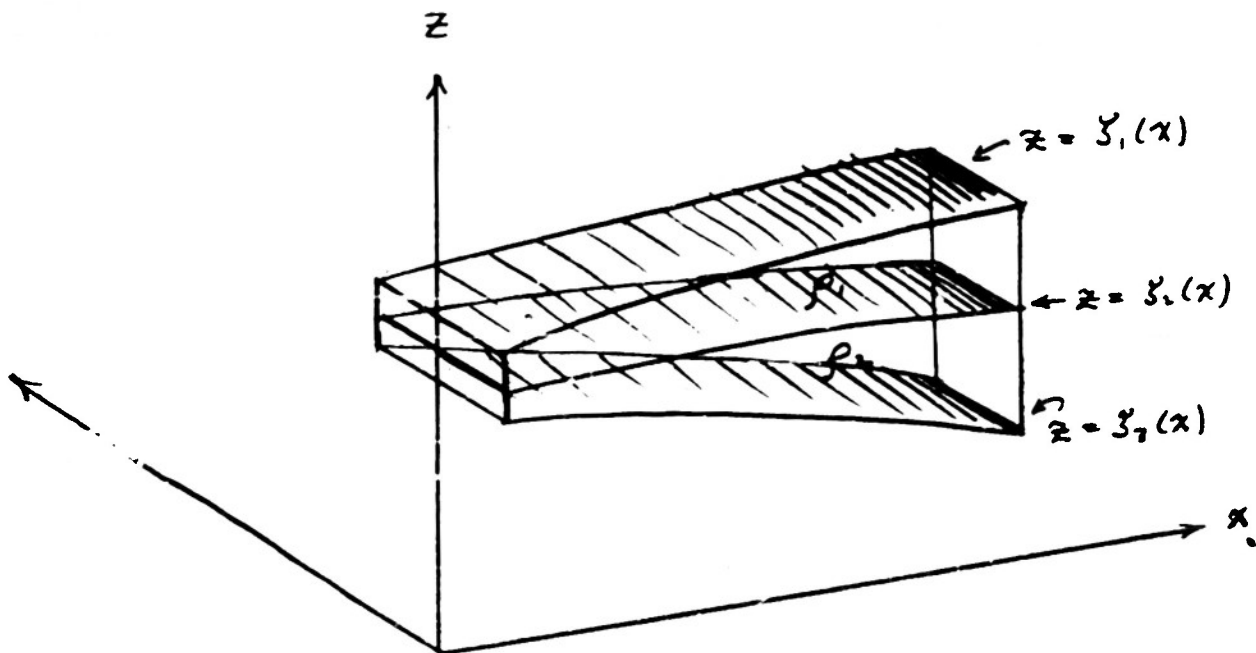

For convenience auxiliary quantities are introduced:

the layer depths:

$$D_1 = \zeta_1 - \zeta_2 \quad D_2 = \zeta_2 - \zeta_3$$

the discharges per unit width:

$$q_1 = D_1 u_1 \quad q_2 = D_2 u_2$$

and the total discharges:

$$Q_1 = b q_1 \quad Q_2 = b q_2$$

The steady state equation of motion in the x -direction is

$$\rho u \frac{\partial u}{\partial x} + \rho v \frac{\partial u}{\partial y} + \rho w \frac{\partial u}{\partial z} = -\frac{\partial p}{\partial x} + \frac{\partial}{\partial z} \left(\mu \frac{\partial u}{\partial z} \right) - \phi(u) \quad (1)$$

The viscous term is supposed to be primarily vertical (as might be the case in a wide channel with thin layers) and it is supposed that μ the dynamic eddy viscosity, may be a function of z . Therefore the term $\frac{\partial}{\partial z} \left(\mu \frac{\partial u}{\partial z} \right)$ is used instead of the usual $\mu \nabla^2 u$

The additional term $-\phi(u)$ is intended to include retarding forces such as might be due to a fine screen, or pilings, or long grass.

The steady state equation of continuity is

$$\frac{\partial}{\partial x} (\rho u) + \frac{\partial}{\partial y} (\rho v) + \frac{\partial}{\partial z} (\rho w) = 0 \quad (2)$$

Now we know that the following identities hold:

$$\rho u \frac{\partial u}{\partial x} = \frac{\partial}{\partial x} (\rho u^2) - u \frac{\partial}{\partial x} (\rho u) \quad (3)$$

$$\rho v \frac{\partial u}{\partial y} = \frac{\partial}{\partial y} (\rho uv) - u \frac{\partial}{\partial y} (\rho v) \quad (4)$$

$$\rho w \frac{\partial u}{\partial z} = \frac{\partial}{\partial z} (\rho uw) - u \frac{\partial}{\partial z} (\rho w) \quad (5)$$

By adding these three the last terms vanish on account of the continuity relation, and we may substitute the remaining terms of the right-hand member into the left-hand member of the equation of motion, obtaining the following form:

$$\begin{aligned} \frac{\partial}{\partial x} (\rho u^2) + \frac{\partial}{\partial y} (\rho uv) + \frac{\partial}{\partial z} (\rho uw) \\ = -\frac{\partial p}{\partial x} + \frac{\partial}{\partial z} \left(\mu \frac{\partial u}{\partial z} \right) - \phi(u) \end{aligned} \quad (6)$$

We now integrate this equation vertically over each layer.

First, over the top layer:

$$\begin{aligned} \int_{z_2}^{z_1} \frac{\partial}{\partial x} (\rho u^2 + p) dz + \int_{z_2}^{z_1} \frac{\partial}{\partial y} (\rho uv) + \rho uw \Big|_{z_2}^{z_1} \\ = \mu \frac{\partial u}{\partial z} \Big|_{z_2}^{z_1} - \int_{z_2}^{z_1} \phi(u) dz \end{aligned} \quad (7)$$

The limits ξ_1 and ξ_2 are functions of x .

Differentiation of the following integral yields the following:

$$\begin{aligned} \frac{\partial}{\partial x} \int_{\xi_2}^{\xi_1} (\rho u^2 + p) dz &= \int_{\xi_2}^{\xi_1} \frac{\partial}{\partial x} (\rho u^2 + p) dz \\ &+ \frac{\partial \xi_1}{\partial x} (\rho u^2 + p) \Big|_{\xi_1} - \frac{\partial \xi_2}{\partial x} (\rho u^2 + p) \Big|_{\xi_2} \end{aligned} \quad (8)$$

The vertically integration equation of motion becomes:

$$\begin{aligned} \frac{\partial}{\partial x} \int_{\xi_2}^{\xi_1} (\rho u^2 + p) dz + \frac{\partial}{\partial y} \int_{\xi_2}^{\xi_1} \rho u v dz - \frac{\partial \xi_1}{\partial x} (\rho u^2 + p) \Big|_{\xi_1} \\ + \frac{\partial \xi_2}{\partial x} (\rho u^2 + p) \Big|_{\xi_2} + \rho u w \Big|_{\xi_2}^{\xi_1} = \mu \frac{\partial u}{\partial z} \Big|_{\xi_2}^{\xi_1} \\ - \int_{\xi_2}^{\xi_1} \phi(u) dz \end{aligned} \quad (9)$$

Also, we may integrate over the width of the channel horizontally along y , and dividing the result by $b(x)$, obtain the following expression:

$$\begin{aligned} \frac{\partial}{\partial x} \int_{\xi_2}^{\xi_1} (\rho u^2 + p) dz + \frac{1}{b} D_y \rho u v \Big|_{y=-h}^{y=h} - \frac{\partial \xi_1}{\partial x} (\rho u^2 + p) \Big|_{\xi_1} \\ + \frac{\partial \xi_2}{\partial x} (\rho u^2 + p) \Big|_{\xi_2} + \rho u w \Big|_{\xi_2}^{\xi_1} = \mu \frac{\partial u}{\partial z} \Big|_{\xi_2}^{\xi_1} - \int_{\xi_2}^{\xi_1} \phi(u) dz \end{aligned} \quad (10)$$

At the solid side walls

$$\frac{v}{u} = \frac{1}{2} \frac{\partial b}{\partial x}$$

Therefore the above equation of motion becomes

$$\begin{aligned} & \frac{\partial}{\partial x} \int_{z_2}^{z_1} (\rho u^2 + p) dz + \frac{1}{b} \frac{db}{dx} D_1 \rho_1 u^2 - \frac{\partial z_1}{\partial x} (\rho u^2 + p) \Big|_{z_1} \\ & + \frac{\partial z_2}{\partial x} (\rho u^2 + p) \Big|_{z_2} + \rho u w \Big|_{z_2}^{z_1} = \mu \frac{\partial u}{\partial z} \Big|_{z_2}^{z_1} \end{aligned} \quad (11)$$

$$- \int_{z_2}^{z_1} \phi(u) dz$$

We now study each of the two layers separately. Suppose that within the top layer u is uniform with \bar{u} , that is, has a value we may designate as u_1 . The hydrostatic pressure is

$$p_1 = \rho_1 g (z_1 - z)$$

Therefore

$$\int_{z_2}^{z_1} (\rho u^2 + p) dz = D_1 \rho_1 u_1^2 + \rho_1 g \frac{D_1^2}{2} \quad (12)$$

If no fluid comes through the top boundary

$$\frac{w}{u_1} = \frac{\partial \zeta_1}{\partial x} \quad \text{at } z = \zeta_1 \quad (13)$$

or more simply

$$\rho u w \Big|_{\zeta_2}^{\zeta_1} = \rho_1 u_1^2 \frac{\partial \zeta_1}{\partial x} - \rho u w \Big|_{\zeta_2} \quad (14)$$

At the interface $z = \zeta_2(x)$ there may be some flow of deep water up into the upper layer, so that if w_m is the upward velocity of water penetrating the interface we can write our expression as

$$\rho u w \Big|_{\zeta_2}^{\zeta_1} = \rho_1 u_1^2 \left(\frac{\partial \zeta_1}{\partial x} - \frac{\partial \zeta_2}{\partial x} \right) - \rho_2 u_2 w_m \quad (15)$$

The integrated equation of motion of the top layer then becomes:

$$\frac{\partial}{\partial x} \left(D_1 \rho_1 u_1^2 + g \rho_1 \frac{D_1^2}{2} \right) + \frac{1}{t} \frac{dt}{dx} \rho_1 u_1^2 D_1 + g \rho_1 D_1 \frac{\partial \zeta_2}{\partial x} - \rho_2 u_2 w_m = \tau_1 - \tau_2 - \int \phi(u) dz \quad (16)$$

where

$$\tau_i = \mu \frac{\partial u}{\partial z} \quad \text{at } z = \zeta_i$$

In the bottom layer $p_2 = g \rho_1 D_1 + g \rho_2 (\xi_2 - z)$

$$\begin{aligned} & \frac{\partial}{\partial x} \int_{\xi_3}^{\xi_2} (\rho u^2 + p) dz + \frac{\partial}{\partial y} \int_{\xi_3}^{\xi_2} \rho u v dz - \frac{\partial \xi_2}{\partial x} (\rho u^2 + p) \Big|_{\xi_2} \\ & + \frac{\partial \xi_3}{\partial x} (\rho u^2 + p) \Big|_{\xi_3} + \rho u w \Big|_{\xi_3}^{\xi_2} \\ & = \mu \frac{\partial u}{\partial x} \Big|_{\xi_3}^{\xi_2} - \int_{\xi_3}^{\xi_2} \phi(u) dz \end{aligned}$$

This expression becomes

$$\begin{aligned} & \frac{d}{dx} \left[D_2 \rho_2 u_2^2 + g \rho_1 D_1 D_2 + g \rho_2 \frac{D_2^2}{2} \right] - g \rho_1 D_1 \frac{\partial \xi_2}{\partial x} \\ & + (g \rho_1 D_1 + g \rho_2 D_2) \frac{\partial \xi_3}{\partial x} + \rho_2 u_2 w_m \\ & + \frac{1}{b} \frac{db}{dx} \rho_2 u_2^2 D_2 = \tau_2 - \tau_3 - \int_{\xi_3}^{\xi_2} \phi(u) dz \end{aligned} \tag{17}$$

3.2 A single fluid: effect of friction

Let us first consider a single layer of water of uniform density ρ_1 , and consider the surface ζ_2 as the solid bottom. Let us suppose that there is no frictional stress at the free surface ($\tau_1 = 0$) and that there is no addition of water to the flow ($\omega_m = 0$). The equation (1) then becomes

$$\begin{aligned} \frac{d}{dx} \left(D_1 \rho_1 u_1^2 + g \rho_1 \frac{D_1^2}{2} \right) + \frac{1}{b} \frac{db}{dx} \rho_1 u_1^2 D_1 \\ + g \rho_1 D_1 \frac{\partial \zeta_2}{\partial x} = -\tau_2 \end{aligned} \quad (1)$$

Furthermore, let us first consider a simple channel of constant width ($db/dx = 0$). By continuity $Dg_1/dx = 0$. The equation may be written

$$\frac{d}{dx} \left(\frac{g_1^2}{D_1} + g \frac{D_1^2}{2} \right) + g D_1 \frac{\partial \zeta_2}{\partial x} = -\tau_2 / \rho_1$$

or

$$\frac{dD_1}{dx} \left(-\frac{g_1^2}{D_1^2} + g D_1 \right) = -\frac{\tau_2}{\rho_1} - g D_1 \frac{\partial \zeta_2}{\partial x} \quad (2)$$

The condition of flow in which $dD_1/dx = 0$ is called "uniform flow" by hydraulic engineers (Bakhmeteff, 1932). According to the Chezy formula for very wide channels

$$u_1 = C \sqrt{s_2} \quad s_2 = -\partial \zeta_2 / \partial x$$

or

$$g_1 = D_1 C \sqrt{s_2}$$

where C is the Chezy resistance factor determined by empirical formulas. We designate a quantity $K = D_1 C$ as the conveyance

$$g_1^2 / K^2 = S_2 \quad (3)$$

This corresponds to the case in our formula where

$$\tau_2 / \rho_1 = g D_1 S_2$$

These two formulas can be reconciled if we write $\tau_2 = K \rho_1 u_1^2$ thus

$$K u_1^2 = g D_1 S_2$$

or

$$\frac{K u_1^2}{g D_1} = S_2, \quad K^2 = \frac{g D_1^3}{K}$$

$$C = \sqrt{\frac{g D_1}{K}}$$

Let us solve for

$$dD_1/dx$$

$$\frac{dD_1}{dx} = \frac{-\tau_2 / \rho_1 + g D_1 S_2}{-\frac{g_1^2}{D_1^2} + g D_1} \quad (4)$$

We thus see that the depth of the layer increases or decreases, depending upon the sign of both numerator and

denominator. The case where the denominator vanishes is a critical one; it occurs at a critical velocity of

$$u_c = \sqrt{g D_1}$$

the velocity of propagation of a long gravity wave. If the stream is flowing with a velocity less than the critical one, (i.e., $u < u_c$) the flow is subcritical and the denominator is positive. For supercritical flow the denominator is negative. It is interesting to note that for subcritical flow in a channel with level bottom ($S_b = 0$) the effect of friction on the bottom is to decrease D_1 in the downstream direction and hence to accelerate the flow. The gradually varied flow in most natural watercourses appears to be subcritical, and we will confine our attention to such regimes.

3.3 Single layer: widening the channel

Let us now consider the effect of widening of the channel alone on the flow. The equation (3.1-16) becomes simply

$$\frac{d}{dx} \left(\frac{g_1^2}{D_1} + g \frac{D_1^2}{2} \right) + \frac{1}{b} \frac{db}{dx} \frac{g_1^2}{D_1} = 0 \quad (1)$$

Now by continuity

$$\frac{d}{dx} (b g_1) = 0 \quad (2)$$

Differentiation of the equation of motion yields

$$\frac{dD_1}{dx} = \frac{\frac{1}{b} \frac{db}{dx} \frac{g_1^2}{D_1}}{g D_1 - \frac{g_1^2}{D_1^2}} \quad (3)$$

The result, in subcritical flow, of a broadening in the channel, is to thicken the single layer.

3.4 Single layer: entrainment

If the only effect permitted is that mass be added to the single layer, (i.e. $w_m \neq 0$) we obtain the following equation:

$$\frac{d}{dx} \left(D_1 \rho_1 u_1^2 + g \rho_1 \frac{D_1^2}{2} \right) - \rho_2 u_2 w_m = 0 \quad (1)$$

This corresponds to a case where water of density ρ_1 is injected into the single layer with a velocity of w_m and u_2 per unit width.

By continuity

$$\frac{\partial}{\partial x} (\rho_1 u_1) + \frac{\partial}{\partial z} (\rho_1 w_1) = 0 \quad (2)$$

$$\int_0^{z_1} \frac{\partial}{\partial x} (\rho_1 u_1) dz + \rho_1 w_1 \Big|_0^{z_1} \quad (3)$$

This is approximately

$$\frac{d}{dx} (D_1 u_1 \rho_1) = \frac{d \rho_1}{dx} = \rho_2 w_m \quad (4)$$

Now going back to the equation of motion

$$\frac{2g_1}{D_1 \rho_1} \frac{d \rho_1}{dx} - \frac{g_1^2}{(D_1 \rho_1)^2} \left(\rho_1 \frac{\partial D_1}{\partial x} + D_1 \frac{\partial \rho_1}{\partial x} \right) + g \rho_1 D_1 \frac{\partial D_1}{\partial x} + g \frac{D_1^2}{2} \frac{d \rho_1}{dx} = \rho_2 u_2 w_m \quad (5)$$

First consider the case where $\rho_2 = \rho_1$, then

$$\frac{\rho_1 g_1 w_m}{D_1} - \frac{g_1^2}{D_1^2 \rho_1} \frac{dD_1}{dx} + g \rho_1 D_1 \frac{dD_1}{dx} = \rho_1 u_2 w_m \quad (6)$$

The equation for the change of D_1 with x is:

$$\frac{dD_1}{dx} = \frac{\rho_1 (u_2 - 2u_1) w_m}{\left(g D_1 - \frac{g_1^2}{D_1^2 \rho_1^2} \right) \rho_1} \quad (7)$$

The result is that in subcritical flow, as long as the injected water is injected with a horizontal velocity, u_2 , more than the stream $2u_1$, the layer will thicken.

The next step is to compare these effects in some special cases where a bottom layer is present.

3.5 Two layers: deep bottom layer

Suppose the deep layer does not move at all, and that it does not mix with the upper layer. In this case, equation (3.1-17) takes on a particularly simple form:

$$\frac{d}{dx} \left(\rho_1 D_1 D_2 + \rho_2 \frac{D_2^2}{2} \right) - \rho_1 D_1 \frac{\partial \check{s}_2}{\partial x} + (\rho_1 D_1 + \rho_2 D_2) \frac{\partial \check{s}_3}{\partial x} = 0 \quad (1)$$

Thus

$$\frac{d}{dx} \rho_1 D_1 D_2 + \rho_2 D_2 \frac{dD_2}{dx} - \rho_1 D_1 \frac{dD_2}{dx} + \rho_2 D_2 \frac{\partial \check{s}_3}{\partial x} = 0 \quad (2)$$

or

$$\frac{d}{dx} (\rho_1 D_1) + \frac{d}{dx} (\rho_2 \check{s}_2) = 0 \quad (3)$$

This equation essentially states that the horizontal pressure gradient in the bottom layer vanishes.

We may now combine this expression with the equation (3.1-16) to obtain

$$\frac{d}{dx} \left[D_1 \rho_1 u_1^2 + g \rho_1 \frac{D_1^2}{2} \right] + \frac{1}{h} \frac{db}{dx} \rho_1 u_1^2 D_1 - g \frac{\rho_1^2}{\rho_2} D_1 \frac{dD_1}{dx} = -\tau_2 \quad (4)$$

or introducing

$$\gamma = \Delta \rho / \rho$$

$$\frac{dD_1}{dx} = \frac{-\tau_2 + \frac{\rho_1^2}{D_1 \rho_1^2} \frac{1}{t} \frac{dt}{dx}}{g \gamma D_1 - \frac{\rho_1^2}{D_1^2 \rho_1^2}} \quad (5)$$

The denominator defines a new critical velocity $u_c = \sqrt{g \gamma D_1}$, which is considerably less than that for one layer flow, $u_c = \sqrt{g D_1}$. Velocities of flow whose interfacial Froude number $F_i = \frac{u_1^2}{g \gamma D_1}$ is less than unity we may call subcritical. It is seen that the same general effects that occur in the subcritical, one-layer case, $F_s < 1$ occur in subcritical (referred to F_i) two-layered flow, except that the behavior of the top layer is, so to speak, inverted vertically.

3.51 Effect of entrainment

Suppose that the lower layer is very deep, but that mixing occurs across the interface. The model therefore is of this kind:

(i) The interface $z = \zeta_2(x)$ permits upward movement of deep water into the top layer where it is mixed, but no mixing downward is permitted. Thus, ρ_2 is independent of x , but $\rho_1(x) \rightarrow \rho_2$ as $x \rightarrow \infty$. The mixing may be due to winds, tidal currents, or the shear developed at the interface, but in this model it is regarded as fixed independently of the mean flow.

(ii) The depth of the top layer, D_1 , is very much less than that of the bottom layer.

(iii) Within the top layer mixing is so strong vertically that the density $\rho_1(x)$, the velocity $u_1(x)$, are independent of z .

The velocity of mixing of deep water into the upper layer is w_m . The mass flux per unit width of the top layer, $D_1 \rho_1 u_1$, increases by the addition of deep water at the rate $\rho_2 w_m$ so that by mass continuity the following relation must obtain:

$$\frac{d}{dx} (D_1 \rho_1 u_1) = w_m \rho_2 \quad (1)$$

If the salinity of the two layers are denoted by S_1 and S_2 , respectively, the salt transfer per unit width in the top layer, $D_1 u_1 S_1$, increases by addition of salt water from below, and by conservation of salt the following relation is obtained:

$$\frac{d}{dx} (D_1 u_1 S_1) = w_m S_2 \quad (2)$$

If the density is simply a linear function of salinity, $\rho = \rho_0 (1 + \alpha S)$ equations (1) and (2) combine to yield the following form of relation:

$$\frac{d}{dx} (D_1 u_1) = w_m \quad (3)$$

Because of its great depth, the velocities in the deep layer are small, and hence the horizontal pressure gradient at any depth within the deep layer must vanish. This is expressed by an earlier equation:

$$\frac{d}{dx} (\rho_1 D_1 + \rho_2 S_2) = 0 \quad (4)$$

Equation (1) simplifies to the following form:

$$\frac{d}{dx} [D_1 \rho_1 u_1^2] = - \frac{d}{dx} \left[\frac{g \rho_1 D_1^2}{2} \right] - g \rho_1 D_1 \frac{d\zeta_2}{dx} \quad (5)$$

By elimination of ζ_2 between equations (4) and (5) the following equation is obtained

$$\frac{d}{dx} \left[D_1 \rho_1 \left(u_1^2 + \frac{g D_1}{2} \gamma \right) \right] = 0 \quad (6)$$

where $\gamma = (\rho_2 - \rho_1) / \rho_2$

The meaning of equation (6) can be explained easily if we introduce

$$g_1 = D_1 \rho_1 u_1 \quad (7)$$

a function denoting the transport of the upper layer.

Clearly

$$\gamma = \gamma_0 g_0 / g \quad (8)$$

where the subscript 0 indicates values of γ and g at $x=0$.

The equation (7) then becomes

$$\frac{d}{dx} \left[\frac{g_1^2}{D_1} + \frac{g \gamma_0 g_0}{2} \frac{D_1^2}{g_1} \right] = 0 \quad (9)$$

or if
$$K = g \gamma_0 g_0 / 2$$

$$\frac{d}{dx} \left(\frac{g_1^2}{D_1} + K \frac{D_1^2}{g_1} \right) = 0 \quad (10)$$

Changing variables

$$\frac{dD}{dg} = \frac{1}{u_1} \left[\frac{2u_1^3 - K}{u_1^3 - 2K} \right] \quad (11)$$

or if

$$b = u_1^3 / K \quad (12)$$

$$\frac{dD_1}{dg} = \frac{1}{\sqrt[3]{bK}} \left[\frac{2b-1}{b-2} \right] \quad (13)$$

The numerical values tabulated in Table 3.51.1 indicate that there is a range of b : $0.5 < b < 2.0$, for which the depth of the top layer decreases with increase of transport. In the case of Alberni Inlet this is apparently what happens. Moreover, the value of b increases rapidly after a certain value of the transport, so that evidently the two layer model breaks down where $b \rightarrow 2.0$

The velocity, C , of an internal wave at the interface is given by

$$C^2 = g \gamma D_1$$

From equation (12) one sees that the velocity of the upper layer, u_1 , is equal to C at the value $b=2$. At points further upstream $u_1 < C$.

Tully has communicated to the writer the fact that the internal wave motions of the open sea do not seem to penetrate into the two layer portion of a deep layered estuary. Apparently this point of critical velocity acts as a block to such deep ocean waves and prevents them from progressing into the estuary.

This leads to an interesting result. The mouth of the estuary will act as a control so that $b=2$ at the mouth. The depth of the upper layer is a maximum at $b=0.5$; this corresponds to the place where the velocity of flow is one half the critical velocity.

TABLE 3.51.1

b	$\left[\frac{2b-1}{b-2} \right]$
0	0.5
.2	0.3
.4	0.125
.5	0.0
.6	-0.25
.8	-0.50
1.0	-1.00
1.2	-1.75
1.4	-3.00
1.6	-5.50
1.8	-13.00
2.0	$-\infty$
2.2	$+\infty$
3.0	+5.0
10.0	2.4
100.0	2.01

3.52 Experimental studies of entrainment in a two layer system

In the experimental flume it is possible to add either fresh or salt water to the top layer by means of a shower bath falling onto the free surface. This is an artifice for increasing the discharge of the top layer along the axis of flow. It differs from the natural entrainment process in estuaries in two ways: (1) In estuaries only salt water is available for entrainment, but experimentally we can add either fresh or salt water; (2) In estuaries a counter-flow occurs in the deep water due to the entrainment, whereas in the flume the water is added externally, so that it does not cause a reverse flow in the deep water, but such a flow can be induced by an auxiliary pump.

Equation 3.51.11 may be written in two forms depending on whether the entrained water is fresh or salt.

Fresh water entrained

$$\frac{g_1}{D_1} \frac{dD_1}{dg_1} = P(F_1) = 2 / \left(1 - \frac{1}{F_1}\right) \quad (1)$$

Salt water entrained

$$\frac{g_1}{D_1} \frac{dD_1}{dg_1} = Q(F_1) = \frac{2 \left(1 - \frac{1}{4F_1}\right)}{1 - \frac{1}{F_1}} \quad (2)$$

These two quantities, $P(F_1)$ and $Q(F_1)$ are given in Table 3.52.1. This table is perhaps somewhat easier to use in computing.

The results of experimental runs in the flume are given in Table 3.52.2.

Table 3.52.1

F_i	$P(F_i)$	$Q(F_i)$
0	0.00	
0.1	-0.22	+0.33
0.2	-0.50	+0.13
0.25	-0.66	0.00
0.3	-0.68	-0.15
0.4	-1.34	-0.50
0.5	-2.0	-1.00
0.6	-3.0	-1.74
0.7	-4.6	-2.95
0.8	-8.0	-5.50
0.9	-18.0	-13.00
1.0	$-\infty$	$-\infty$

Table 3.52.2

	Run				
	1	2	3	4	5
River discharge per unit width $\text{cm}^2\text{sec}^{-1}$	15.8	31.4	31.4	11.4	11.4
Shower discharge per unit width $\text{cm}^2\text{sec}^{-1}$	7.9	12.8	12.2	11.4	11.4
Shower Fresh or Salt	S	F	S	F	S
D_i	9.0	10.0	10.0	14.2	13.8
D_i'	8.0	8.0	8.5	13.8	16.2
D_i^3	720	1000	1000	2850	2620
$D_i'^3$	510	510	610	2640	4250
ρ_i	1.009	1.005	1.004	1.009	1.009
ρ_i'	1.018	1.011	1.014	1.009	1.016
γ	.018	.022	.023	.018	.018
γ'	.009	.016	.013	.018	.011
	—	—	—	(Transition downstream)	
F_i	.044	.068	.204	.004	.0049
F_i'	.502	.680	.495	.0385	.0201
$\Delta D_i / \bar{D}_i$	-.11	-.22	-.17	-.03	+.17
$\Delta \rho_i / \bar{\rho}_i$.66	.64	.54	.68	.61
$(\rho_i / D_i) (\Delta D_i / \Delta \rho_i)$	-.16	-.34	-.31	-.04	+.25
\bar{F}_i	.30	.36	.35	.021	.0110
$P(F_i) \text{ or } Q(F_i)$	-.15	-.00	-.32	-.04	+.50

Primes denote position downstream of shower.

3.53 Example of calculation of interfacial depth in a deep estuary dominated by entrainment.

The salinity of the ocean off Alberni Inlet is about 32 ‰. For purposes of the computation we choose the salinity of the upper layer as 30.6 ‰ at the mouth. The channel is of more or less uniform width, about 1500 m. The river discharge varies, but we will compute a curve for a discharge of $60 \text{ m}^3 \text{ sec}^{-1}$. This corresponds to a fresh water discharge per unit width $q_0 = 400 \text{ cm}^2/\text{sec}$. The initial density difference is taken as $\gamma_0 = 0.025$. At the mouth $q_c = 10^4 \text{ cm}^2/\text{sec}$ and $\gamma_c = 0.001$. The depth at the mouth is therefore given by the critical interfacial Froude number F_i being unity there :

$$F_i = \frac{q_c^2}{g \gamma_c D_c^3} = 1$$

Thus $D_c = 4.65 \times 10^2 \text{ cm}$.

We may now compute the interfacial depths at various points upstream by means of equation (3.51.10):

$$\frac{q_i^2}{D_i} + \frac{g \gamma_i D_i^2}{2} = C$$

where the constant C is determined at the mouth:

$$C = \frac{3}{2} g \gamma_c D_c^2$$

A table of such computations for a few selected values of γ_1 is given in Table 3.53.1. Depths of the top layer from Alberni Inlet are given as well.

By differentiation of the equation (3.51.10) it is found that the maximum depth of the interface is:

$$D_{i(\max)} = 1.26 D_c$$

and that this occurs at the station where

$$\gamma_1 = 1.26 \gamma_c$$

In the example we are here computing

$$D_{i(\max)} = 5.7 \text{ m at } \gamma_1 = 0.0013$$

Table 3.53.1

Computation for layer depth in Alberni Inlet			Actual layer depth in Alberni Inlet		
γ_1	D_1 (m.)	S ‰	S ‰	D_1 (m.)	Stat.
.001	4.65	31.0	31	4.5	H
.0015	5.6	30.0	29.5	2.0	G
.002	5.2	29.5	29.0	2.0	F
.004	3.9	27.0	28	1.5	E*
.012	2.3	16.6	26	4.0	D*
.020	1.8	6.4	19	2.0	C
.025	.5	0.0	11	2.2	B
			5	2.0	A

* Station is in a widening of the channel.

3.6 Salt wedge

An interesting special case of gradually varied flow is the salt wedge which occurs in channels where the depth is insufficient to permit the salt water to extend throughout the whole length of the channel, so that the downstream part of the channel has two layers of fluid in it, and the upstream part of the channel has only a fresh water layer. The wedge appears to be a phenomenon in which friction is more important than entrainment. Moreover, it is important to distinguish between steady salt wedges and the type of cold front discussed by von Karman (Non-linear engineering problems. Bull. Am. Math. Soc., 46, 8, pp. 615-683). In von Karman's wedge vertical velocities are important, the pressures are not hydrostatic, and the slope of the wedge surface is nearly 1:1. The slopes of stationary wedges occurring in estuaries are likely to be more of the order 1:40 or 1:100.

The hypothesis which is used in this section to construct a theoretical model of the salt wedge phenomenon is that the upper layer is turbulent, whereas the wedge itself is laminar. We shall use equation (3.1-16) which is the equation of motion of the top layer vertically integrated in which there is no entrainment, no free surface stress, and no change in section of the channel.

$$\frac{d}{dx} \left(D \rho u^2 + \rho g \frac{D^3}{2} \right) + \rho g D \frac{\partial \zeta}{\partial x} = - \tau_2 \quad (1)$$

The turbulent stress on the interface is taken to be

$$\tau_2 = k \rho_1 u_1^2 \quad (2)$$

The fluid in the wedge itself is presumed to be governed by the Navier-Stokes equations, but the velocities are so small that the inertial terms are neglected. (It will be noticed that the inertial terms are not neglected in the integrated form of the equation for the top layer). The equation for the lower layer, then, is of the following form:

$$\frac{1}{\rho_2} \frac{\partial p_2}{\partial x} = \nu_2 \frac{\partial^2 u_2}{\partial z^2} \quad (3)$$

If it is assumed that the vertical velocities are small and that therefore the pressure is hydrostatic, equation (3) may be written in the following form:

$$g \left(\alpha \frac{\partial \zeta_1}{\partial x} + \beta \frac{\partial \zeta_2}{\partial x} \right) = \nu_2 \frac{\partial^2 u_2}{\partial z^2} \quad (4)$$

$$\alpha = \rho_1 / \rho_2 \quad \beta = (\rho_2 - \rho_1) / \rho_2$$

The stress exerted by the upper fluid on the lower fluid and given by equation (2) must be balanced by a viscous shearing stress due to the lower fluid acting on the upper.

$$\tau_2 = \nu_2 \rho_2 \frac{\partial u_2}{\partial z} \quad \text{at } z = \zeta_2 \quad (5)$$

We may assume that the velocity used for (2) in the lower layer is given by the following form:

$$u_1 = a + bz + cz^2 \quad (6)$$

in which case equation (4) becomes the following:

$$g \left(\alpha \frac{\partial \xi_1}{\partial x} + \beta \frac{\partial \xi_2}{\partial x} \right) = \nu_2 \cdot 2c \quad (7)$$

and equation (5) becomes simply

$$\frac{\tau_2}{\mu} = b + 2c \xi_2 \quad (8)$$

If the velocity of the lower layer vanishes at the bottom, a vanishes.

Since we assume no transfer of salt water across the interface there must be no net flow of salt water across any section of the wedge.

$$\int_0^{\xi_2} u_1 dz = 0 \quad (9)$$

Evaluation of this integral results in the following relation:

$$0 = b + \frac{2}{3} \xi_2 c \quad (10)$$

From equations (8) and (10) we can solve for the constant C and substituting this into equation (7) we obtain the following form of the equation for the lower layer:

$$g \zeta_2 \left(\alpha \frac{\partial \zeta_1}{\partial x} + \beta \frac{\partial \zeta_2}{\partial x} \right) = \frac{3}{2} \tau_2 \quad (11)$$

Making use of the fact that

$$D_1 = \zeta_1 - \zeta_2 \quad (12)$$

$$Q = \nu_1 D_1 \quad (13)$$

and equations (2), (1), and (11), we can eliminate all the variables except ζ_1 and ζ_2 so that the equations are now reduced to two equations of the following form:

$$\left(\frac{1}{F} - 1 \right) \frac{\partial \zeta_1}{\partial x} + \frac{\partial \zeta_2}{\partial x} = -k \quad (14)$$

$$\frac{1}{\alpha F} \frac{\zeta_2}{\zeta_1 - \zeta_2} \left(\alpha \frac{\partial \zeta_1}{\partial x} + \beta \frac{\partial \zeta_2}{\partial x} \right) = \frac{3}{2} k \quad (15)$$

where for convenience

$$F = \frac{g^2}{g(\zeta_1 - \zeta_2)^3} \quad (16)$$

We place the origin of the coordinate system at the head of the wedge and introduce the quantity D_0 which is given by the equation

$$\zeta_1 = D_0 \quad \text{at} \quad x = 0 \quad (17)$$

We then introduce a change in variable:

$$\frac{\partial \zeta_1}{\partial x} = D_0 \frac{\partial \lambda_1}{\partial x} \quad , \quad \frac{\partial \zeta_2}{\partial x} = D_0 \frac{\partial \lambda_2}{\partial x} \quad (18)$$

and rewrite equations (14) and (15) in the forms

$$\left(\frac{1}{F} - 1\right) \frac{\partial \lambda_1}{\partial x} + \frac{\partial \lambda_2}{\partial x} = -\frac{k}{D_0} \quad (19)$$

$$\frac{1}{\alpha F} \frac{\lambda_2}{\lambda_1 - \lambda_2} \left(\alpha \frac{\partial \lambda_1}{\partial x} + \beta \frac{\partial \lambda_2}{\partial x} \right) = \frac{3}{2} \frac{k}{D_0} \quad (20)$$

Eliminating the quantity $\frac{\partial \lambda_1}{\partial x}$ from the above equations, we obtain

$$\left(\frac{1}{F_2} - \frac{\alpha}{1-F}\right) \frac{\partial \lambda_2}{\partial x} = \frac{\alpha k}{D_0} \left(\frac{1}{1-F} + \frac{3}{2} \frac{\lambda_1 - \lambda_2}{\lambda_2}\right) \quad (21)$$

where $F_2 = F/\beta$, the interfacial Froude number. It should be noted that F_2 and F are not constants, but are functions of (ζ_1, ζ_2) .

In order to simplify equation (21) so that it may be conveniently integrated, we make the following substitutions which have been substantially verified in the laboratory:

$$F \ll 1, \quad \lambda_1 \cong 1 \quad (22)$$

Equation (21) now takes the form

$$\frac{\partial \lambda_2}{\partial x} = \frac{\frac{3}{2} \frac{k}{D_0}}{\frac{(1-\lambda_2)^3}{\alpha F_{i0}} - 1} \left\{ \frac{1}{\lambda_2} - \frac{1}{3} \right\} \quad (23)$$

where $F_{i0} = \frac{Q^2}{g\beta D_0^3}$, the interfacial Froude number at $x=0$. As λ_2 is a function of x only, equation (22) may be written in integral form:

$$\int_0^{\lambda_2} \frac{(1-\lambda_2)^3 - \alpha F_{i0}}{3-\lambda_2} \lambda_2 d\lambda_2 = \frac{1}{2} \frac{k}{D_0} \alpha F_{i0} \int_0^x dx \quad (24)$$

Upon carrying out the prescribed integration and collecting terms, we obtain as the final equation which describes the profile of the salt water wedge

$$\frac{k}{2} \alpha F_{i0} \frac{x}{D_0} = \frac{\lambda_2^4}{4} + \frac{3}{2} \lambda_2^2 + (8 + \alpha F_{i0}) \left(\lambda_2 - 3 \ln \frac{3}{3-\lambda_2} \right) \quad (25)$$

This equation involves no other assumptions than equations (2) and (22), and will therefore be considered exact. It is used to determine the interfacial coefficient of friction, k .

Unfortunately, equation (25) is very inconvenient with which to work. We may simplify the equation in the following manner. If αF_{10} is of the order 1/10 it may be considered small compared to the number 8. Expanding the natural logarithm in series and collecting terms we obtain

$$\frac{k'}{2} \alpha F_{10} \frac{x}{D_0} = \frac{1}{6} \lambda_2^2 - \frac{8}{27} \lambda_2^3 + \frac{19}{108} \lambda_2^4 - \dots \quad (26)$$

The validity of this approximate form of equation (25) may be checked by comparison with the experimental data. k' has been substituted for k in event of a shift along one of the axes due to the approximation.

The interfacial Froude number, F_i , increases with increasing X . As F_i cannot exceed unity (see Section 2.21) we may say

$$F_{10} \leq F_i \leq 1 \quad (27)$$

The condition that $F_i = 1$, therefore defines the maximum thickness of the wedge, and permits a determination of the maximum length of the wedge. The following quantities are

now defined

$$aI F_c = 1, \quad x = X_m, \quad \lambda_2 = \lambda_{2m} \quad (28)$$

We may determine the maximum value of λ_2 from the equation

$$F_c = 1 = \frac{Q^2}{g\beta D_0^3 (1 - \lambda_{2m})^3} = \frac{F_{c0}}{(1 - \lambda_{2m})^3}$$

and therefore

$$\lambda_{2m} = 1 - F_{c0}^{1/3} \quad (29)$$

Using equations (29), (23) and (18), we may determine the slope of the interface at $X = X_m$

$$\left(\frac{\partial J_2}{\partial X} \right)_{X=X_m} = \frac{k}{\beta} \frac{\alpha}{2} \left(\frac{2 + F_{c0}^{1/3}}{1 - F_{c0}^{1/3}} \right) \quad (30)$$

3.61 Experimental studies of salt wedges

The experimental salt wedges in the laboratory exhibit a form similar to equation (3.6.25), as shown in Figure 3.61.1. The solid lines indicate the wedge profiles determined by the above equation. By fitting the experimental points to these curves, the interfacial coefficient of friction is found to equal

$$k = 0.0036 \quad (1)$$

The theoretical curves have been terminated at the value of λ_2 defined by equation (3.6.29). None of the experimental data exceeded this limit.

In order to fit the experimental data to equation (3.6.26), the approximate equation, it is necessary to make

$$k' = 0.0051 \quad (2)$$

Figure 3.61.2 shows these results, the dashed line indicating the curve given by equation (3.6.26). As the approximation involved the omission of a number of terms multiplied by αF_{10} it is not believed that k' bears any significant relation to k .

The solid line in Figure 3.61.2 indicates the following empirical relation found prior to the foregoing theory

$$\lambda_2 = 0.15 \left(\frac{x}{D_0} F_{10} \right)^{.52} \quad (3)$$

A further check on the theoretical analysis would be that the velocity in the wedge be approximately correct. The maximum upstream velocity occurs at $\xi_2/3$ and

$$u_{2max} = -\frac{\tau}{\mu_2} \frac{\xi_2}{12} \quad (4)$$

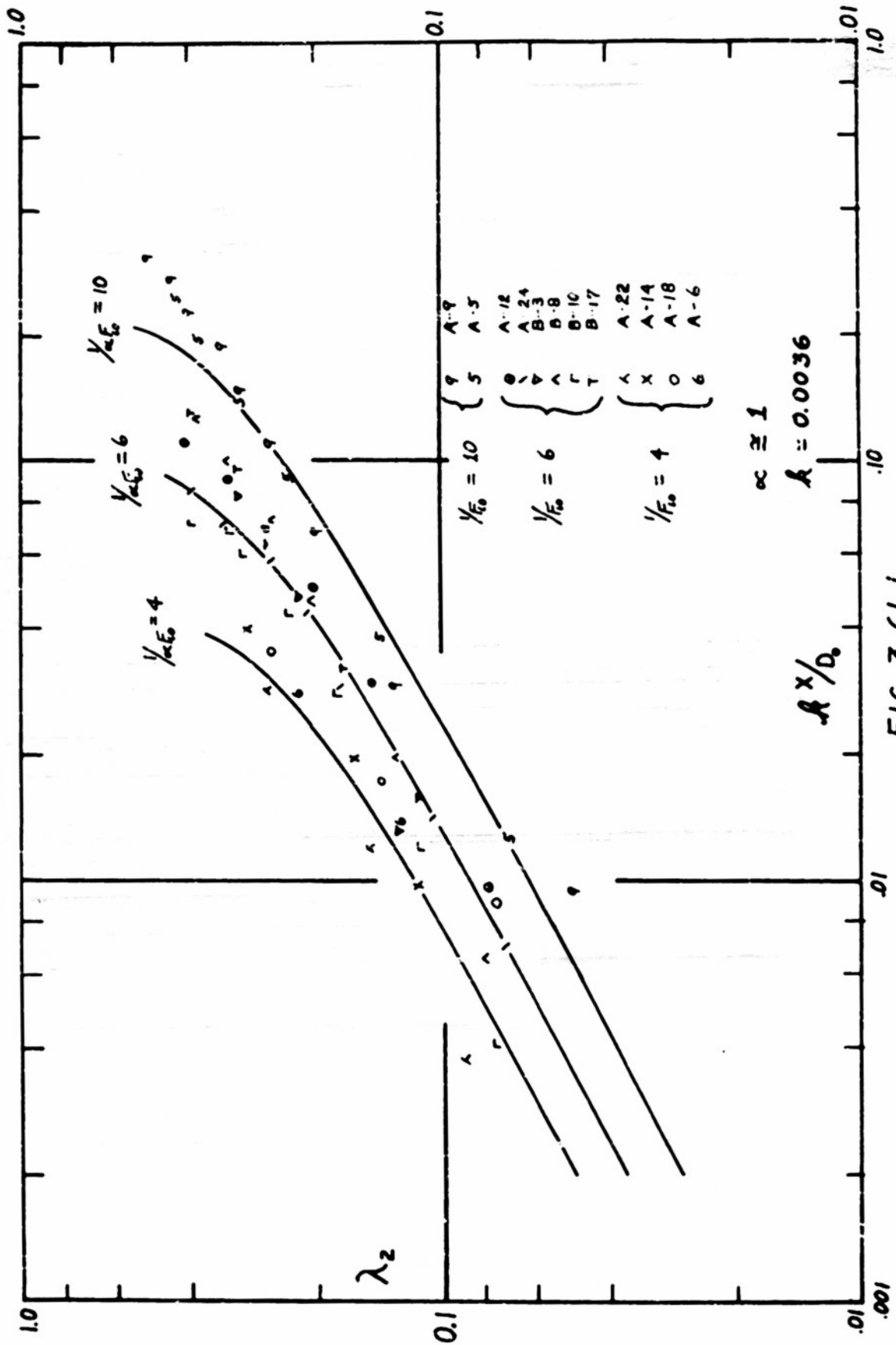

FIG. 3.61.1

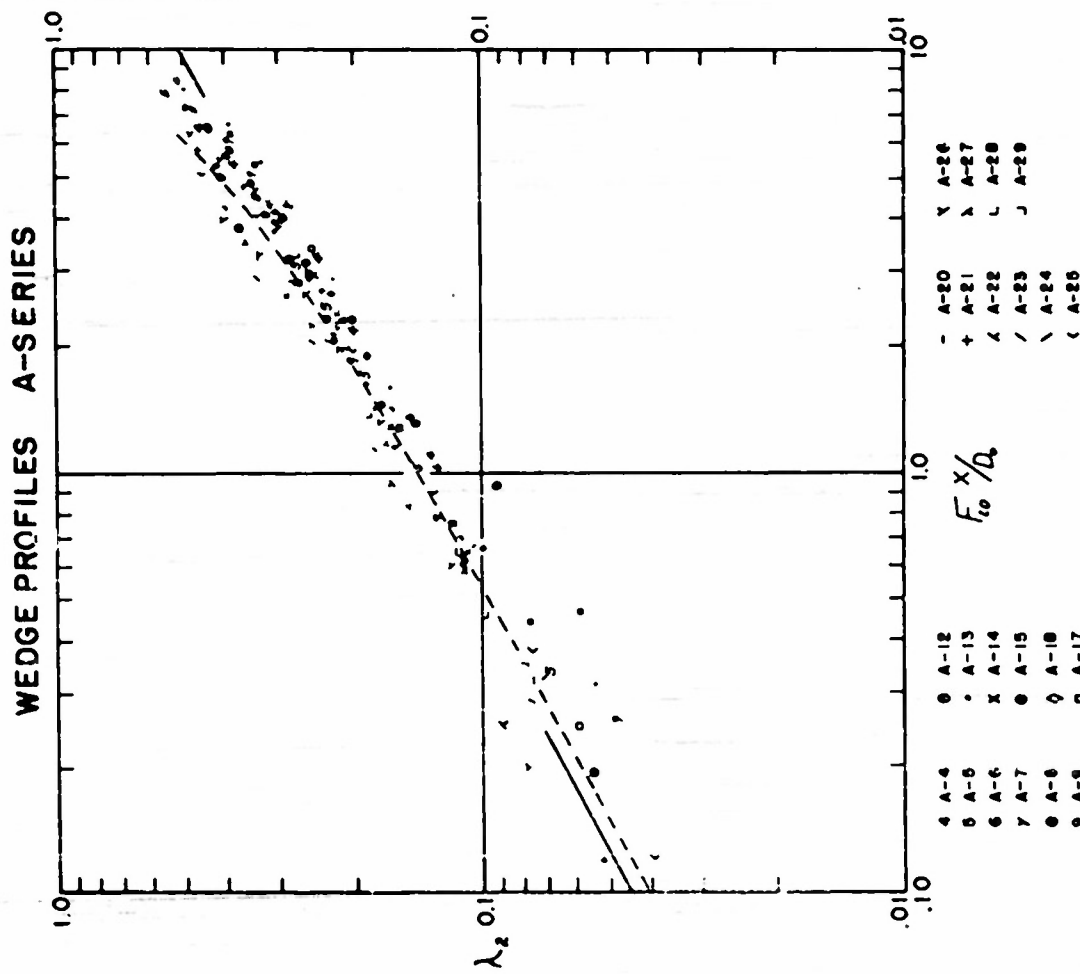
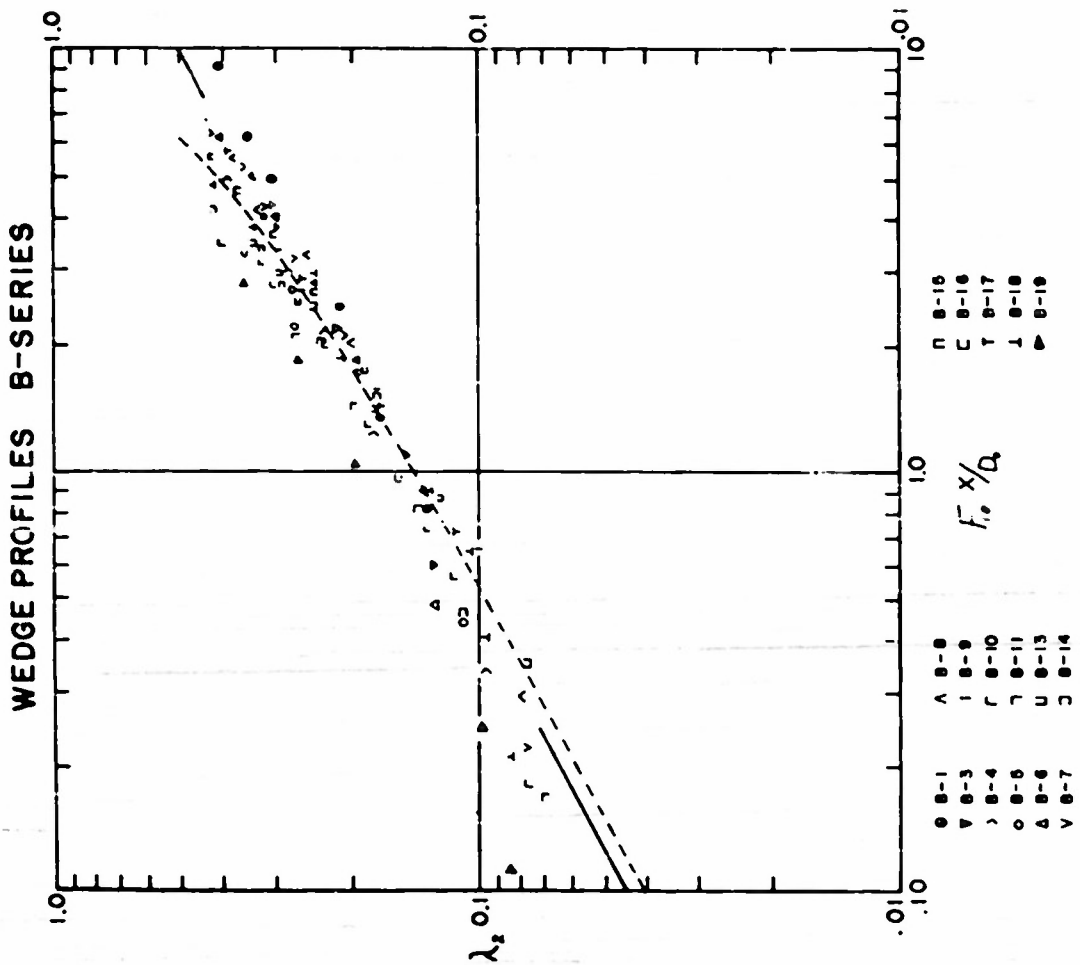

FIG. 3.61.2

3.7 The very viscous estuary

Certain estuaries, though stratified, are so turbulent that the deep layer is diluted with fresh surface water. These estuaries (Type 2) differ from the deep-fjord estuary (Type 3), and river outlet (Type 4) in which the bottom layer is undiluted.

Continuity principles show that whereas entrainment can occur without turbulent flux across the interface, turbulent flux must be accompanied by entrainment. This and other matters are discussed in Section 4.6.

In this chapter the interesting feature of the very viscous estuary is that inertia terms may not be important as compared to friction and pressure terms. An elementary theory of such a case may be developed as follows:

The dynamical equations (3.1.16) and (3.1.17) may be simplified to the following forms if inertia terms are neglected.

$$\frac{d}{dx} \left(g \rho_1 \frac{D_1^2}{2} \right) + g \rho_1 D_1 \frac{\partial \zeta_1}{\partial x} = -\kappa (u_1 - u_2) \quad (1)$$

$$\frac{d}{dx} \left(g \rho_2 D_2 \frac{D_2^2}{2} \right) - g \rho_2 D_2 \frac{\partial \zeta_2}{\partial x} = \kappa (u_1 - u_2) \quad (1')$$

where the frictional stress has been written in the form

$\tau_L = K(u_1 - u_2)$. It is convenient to write the equations with g_1 as independent variable, and let

$v = K/(dg_1/dx)$ where

$$\frac{d}{dg_1} \left(g_1 \rho_1 \frac{D_1^2}{2} \right) + g_1 \rho_1 D_1 \frac{\partial \xi_1}{\partial g_1} = -v(u_1 - u_2) \quad (2')$$

$$\frac{d}{dg_2} \left(g_1 \rho_1 D_1 D_2 + g_2 \rho_2 \frac{D_2^2}{2} \right) - g_1 \rho_1 D_1 \frac{\partial \xi_2}{\partial g_1} = v(u_1 - u_2) \quad (2'')$$

Addition of these two leads to the simple result that

$$\frac{d}{dg_1} \left[\rho_1 \frac{(D_1 + D_2)^2}{2} + (\rho_2 - \rho_1) \frac{D_2^2}{2} \right] = 0 \quad (3)$$

This equation simply states that in the absence of bottom friction the vertically integrated pressure force does not vary with x .

Now in a Type 2 estuary, with reasonably large value of v , the term $\partial(\rho_2 - \rho_1)/\partial g_1$ is small compared to the others, and in many cases so is $\partial D_2^2/2 \partial g_1$, so that the principal balance is in the form

$$\frac{d}{dg_1} \left(\rho_1 \frac{(D_1 + D_2)^2}{2} \right) = 0 \quad (4)$$

or quite simply

$$\frac{\partial \zeta_1}{\partial g_1} = -\frac{1}{\rho'} \frac{\partial \rho_1}{\partial g_1} \frac{(D_1 + D_2)}{2} \quad (5)$$

If we suppose that the density is given by a simple law

of the type $\rho = \rho_0(1 + \alpha s)$ then

$$\frac{\partial \zeta_1}{\partial g_1} = -\alpha \frac{\partial s_1}{\partial g_1} \frac{(D_1 + D_2)}{2} \quad (6)$$

From equation (4.6.3) we can now write

$$\frac{\partial \zeta_1}{\partial g_1} = \alpha \left(\frac{D_1 + D_2}{2} \right) \frac{1}{g_1} (1 + \gamma) (s_1 - s_2) \quad (7)$$

Now from the dynamical equation (2)

$$D_1^2 g \frac{\partial \zeta_1}{\partial g_1} = -\gamma (\alpha_1 - \alpha_2) D_1 \cong -2g_1 \gamma \quad (8)$$

If we eliminate $\partial \zeta_1 / \partial g_1$ between equations (7) and (8) we obtain an equation giving g_1 in terms of the observed salinity distribution (in a Type 2 estuary):

$$g_1^2 = g \alpha \frac{(D_1 + D_2)}{2} \frac{D_1^2}{2} \frac{(1 + \gamma)}{\gamma} (s_2 - s_1) \quad (9)$$

This equation, despite its restrictions and its approximate nature, is very remarkable. If we consider any Type 2 estuary, we can deduce the discharge q_1 , or the non-tidal velocities, u_1 , from the salinity distribution, even though we do not know the friction explicitly! The alternate form of (9) is as follows:

$$u_1 = \frac{1}{2} \sqrt{g \alpha (D_1 + D_2) \frac{1 + \gamma}{\gamma} (s_2 - s_1)} \quad (9')$$

An interesting corollary of the equation (9) is that, for large γ :

$$\frac{(s_2 - s_1)^3}{g_0^2 s_2^2} \approx g \alpha \frac{D_1^2}{2} \frac{D_1 + D_2}{2} \quad (10)$$

or, as in most Type 2 estuaries, if $D_1 = D_2 = \frac{1}{2} h$

$$\frac{(s_2 - s_1)^3}{s_2^2} \approx g \alpha g_0^2 h^3 / 16 \quad (10')$$

3.71 Example. Dynamics of a Type 2 estuary.

Pritchard (1951) has discussed in detail the numerical magnitude of various terms in the dynamical equation for the James River estuary (for the discussion of the salt transfer equation of the James, see Section 4.61). The dynamical equation for the x-component is averaged over time, a steady state is supposed, and the following form obtained:

$$\bar{u} \frac{\partial \bar{u}}{\partial x} + \bar{w} \frac{\partial \bar{u}}{\partial z} = -\frac{1}{\rho} \frac{\partial \bar{p}}{\partial x} - \frac{\partial}{\partial x} (\overline{u'^2}) - \frac{\partial}{\partial z} (\overline{u'w'}) - (\overline{u'w'}) \frac{1}{b} \frac{db}{dz} \quad (1)$$

By analogy to the fact that he found $\overline{u's'}$ negligible, (Section 4.61) Pritchard infers that $\frac{\partial}{\partial x} (\overline{u'^2})$ is also negligible. Hence, the vertical eddy flux of momentum may be solved for in the form

$$\overline{u'w'} = -\frac{1}{\bar{w}} \left[\int \bar{w} \left(\bar{u} \frac{d\bar{u}}{dx} + \bar{w} \frac{d\bar{u}}{dz} + \frac{1}{\rho} \frac{d\bar{p}}{dx} \right) dz + C \right] \quad (2)$$

Unless the elevation of the free surface is known, $\frac{1}{\rho} \frac{\partial \bar{p}}{\partial x}$ is known only with respect to a constant fixed at some level z_1 . However, Pritchard assumes that $\overline{u'w'}$ vanishes at both surface and bottom (the latter assumption being by far the weakest) and evaluates $\overline{u'w'}$ numerically from equation (2). The results for a single station are plotted in Figure 3.71.1.

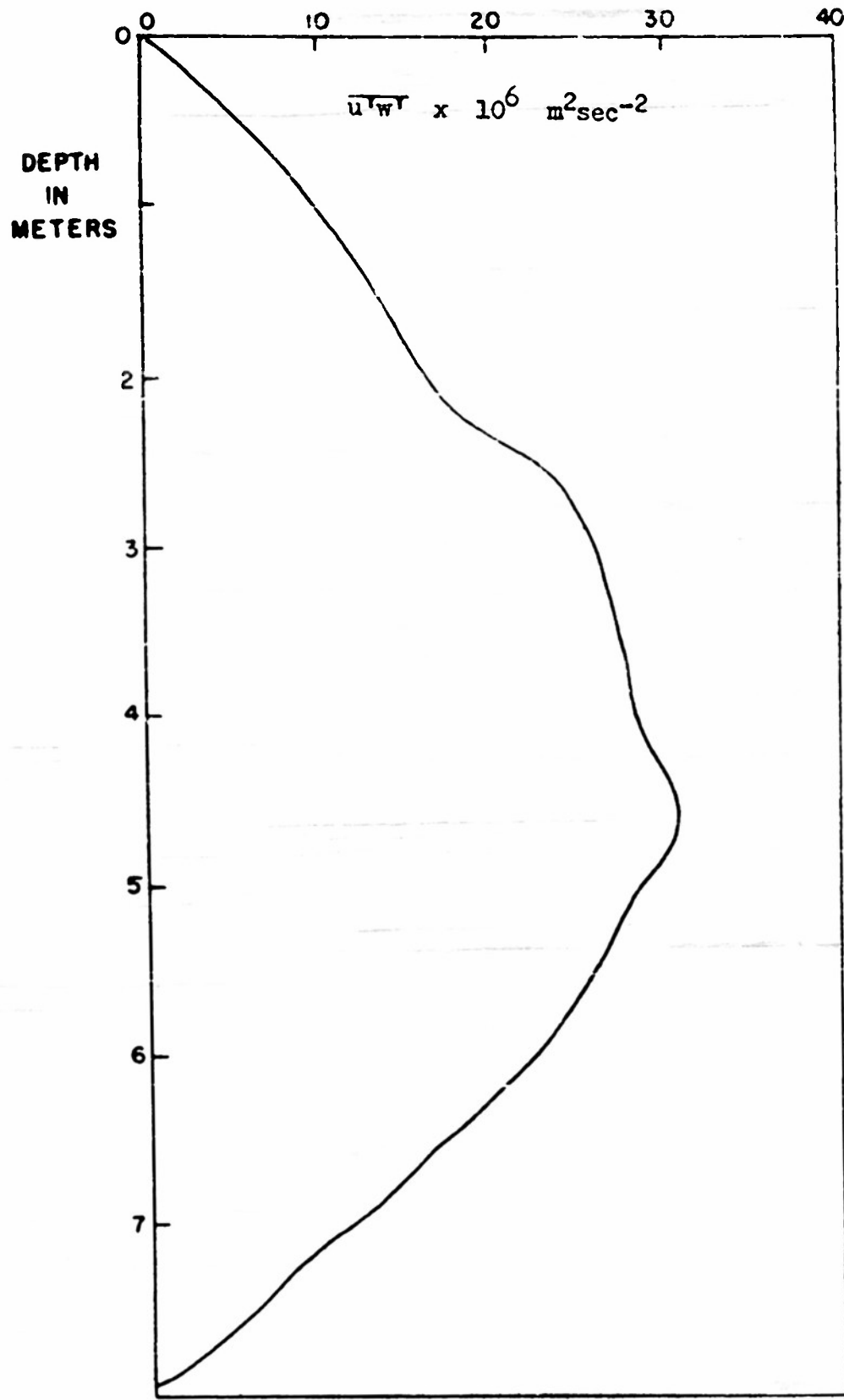

Figure 3.71.1 The vertical eddy flux of horizontal momentum as a function of depth, at a sample station in the James River estuary.

4.1 Mixing processes in estuaries

Very little is known for certain about the mixing processes which actually occur in estuaries, so that most of the work done to date has been hypothetical. These hypothetical studies are essentially an attempt to explain the observed distribution in the estuary of a property like salt on the basis of assumptions about the mixing. The methods of the tidal prism (4.2), of mixing in segments (4.3), and of arbitrarily defined eddy diffusivity (4.4), are examples of this hypothetical approach.

From the practical point of view of computation of pollution, numerical processes seem more likely to be of use than idealized hypothetical mixing theories. Section 4.46 is an example of the numerical process applied to an unstratified estuary.

An interesting feature of mixing in stratified estuaries is the condition of "overmixing" which is discussed in Sections 4.51-3. This condition may turn out to be a very useful one in the study of estuaries because it does not depend upon the detailed nature of the mixing process itself.

4.2 The tidal prism

The first rough approximate method of determining the salinity of a tidal estuary from a knowledge of the tides and river flow is the "tidal prism method", long in use by engineers (Metcalf and Eddy, 1935) in harbor studies.

Denote the high-tide volume of the estuary by V_H , the low tide volume by V_L , the volume of river flow per tidal cycle by R . The tidal prism is defined by

$$P = V_H - V_L$$

If the river water is fresh, and the salinity of the ocean is σ , the salinity of the harbor is obtained by the assumption that on each tidal cycle a volume P of water of salinity σ and a volume R of fresh water, mix thoroughly in the harbor, and that a volume $P+R$ of the mixture is expelled. The salinity of the estuary is therefore $P\sigma/(P+R)$ in the steady state.

4.3 Refinements of the tidal prism method

Ketchum (1951) has suggested that the primary weakness of the tidal prism method is that it assumes complete mixing over the entire estuary during each tidal cycle. He indicated that an estuary should be divided into a number of segments of a length approximately the local displacement of the tide in each of which mixing is complete. Before discussing Ketchum's theory of the exchange ratio we will first discuss various arbitrary ways of dividing the estuary into segments, some of which may be useful in cases where estuaries contain several isolated basins; and show how dependent the results may be on the exact nature of the mixing process.

Suppose that the estuary be divided into arbitrary segments, in each of which mixing is complete. The low-tide volumes of each of these segments are denoted by V_n , the high-tide volume by $P_n + V_n$

The segment $n=0$ is defined to be that where the quantity $P_0 = R$, R being the river discharge per tidal cycle.

If f_n is the fractional concentration of river water in the n th segment at high tide, then the fractional concentration of sea water in each segment is $1 - f_n$ at high tide. Let g_n be the fractional concentration of fresh water in the n th segment at low tide.

The rise of level in segment $n = 0$ during flood tide may be assumed to be due entirely to river flow, thus $f_0 = 1$. Since there is no flux upstream across the seaward boundary of the 0th segment, also $g_0 = 1$.

We now evaluate the flux of volume and fresh water across both the landward and seaward boundaries of the nth segment:

	Volume Flux	Fresh Flux
Ebb - Landward boundary	U_n	$U_n f_{n-1}$
Seaward boundary	U_{n+1}	$U_{n+1} f_n$
Flood - Landward boundary	$-(U_n - R)$	$-(U_n - R) g'_n$
Seaward boundary	$-(U_{n+1} - R)$	$-(U_{n+1} - R) g'_{n+1}$

The freshness of the water flowing in the flood tide is given by g'_n

Let

$$U_n = \sum_{i=0}^{i=n-1} P_i \quad P_0 = R$$

At high and low

	Volume of nth segment	Total Fresh water in nth segment
High	$P_n + V_n$	$(P_n + V_n) f_n$
Low	V_n	$V_n g_n$

The first relation to be satisfied is that the flux of volume across each boundary be R each tidal cycle.

This is clearly so since at landward boundary:

$$U_n - (U_n - R) \equiv R$$

and at seaward boundary:

$$U_{n+1} - (U_{n+1} - R) \equiv R$$

The next relation is that the flux of fresh water volume each complete tidal cycle by R . Thus at the landward boundary

$$U_n f_{n-1} - (U_n - R) g'_n = R \quad (1)$$

and at the seaward boundary

$$U_{n+1} f_n - (U_{n+1} - R) g'_{n+1} = R \quad (1')$$

g'_n and g'_m are in general different, and equal only when mixing is complete on low tide. As a matter of fact, the second equation follows from the first by induction.

By conservation of fresh water the change in fresh water content during the ebb is:

$$g_m V_m - f_n (P_n + V_n) = U_n f_{n-1} - U_{n+1} f_n \quad (2)$$

and during the flood is

$$f_n (P_n + V_n) - g_n V_n = - (U_n - R) g'_n + (U_{n+1} - R) g'_{n+1} \quad (2')$$

A number of different results may now be obtained, depending upon the precise nature of the mixing process supposed.

Mixing process 1. Suppose no mixing occurs at low tide so that on the flood the water flowing across each boundary is unchanged in properties. Formally this is equivalent to supposing that

$$g'_{n+1} = f_n \quad (3)$$

Substitution of this into equation ⁽¹⁾ shows that for this process the only possible steady state is one in which $f_n = 1$

Mixing process 2. Suppose mixing occurs at low tide and the segments are quite large so that in the limit

$$g'_n = f_n$$

If there is a certain value of n , say $n = m$ which lies in the ocean then it is certain that there $g'_m = f_m = 0$. The values of f_n at segments further upstream may be calculated by equation (1).

$$\begin{aligned}
 u_m f_{m-1} &= R \\
 u_{m-1} f_{m-2} &= (u_{m-1} - R) f_{m-1} + R \\
 &\text{etc.}
 \end{aligned}
 \tag{4}$$

There is no difficulty in satisfying the upper boundary between segments 0 and 1.

Mixing process 3. Suppose all the water that moves on the flood is ocean water in the form of a wedge, then $g'_n = 0$ and the f_n at the n th segment is computed by

$$u_{n+1} f_n = R \tag{5}$$

Mixing process 4. Suppose that mixing occurs at low tide in each segment as well as at high tide, thus

$$g'_n = g_n$$

There are two relations available: equations (1) and (2), between which g_n and g'_n may be eliminated, thus yielding a recurrence relation in f_n and f_{n-1} .

$$\begin{aligned} & u_n [V_n - u_n + R] f_{n-1} \\ & - (u_n - R) [P_n + V_n - u_{n+1}] f_n \quad (6) \\ & = R V_n \end{aligned}$$

4.31 Exchange Ratio

Ketchum (1951) has introduced a special type of segmentation which seems to this writer to be the most reasonable "a priori" for unstratified estuaries. In our notation, it consists of defining V_n in terms of the upstream segments:

$$V_n = U_n + V_0 \quad (1)$$

Moreover, Ketchum has introduced a quantity r_n called the exchange ratio, defined in the following way:

$$r_n = P_n / (P_n + V_n) \quad (2)$$

and has postulated that the total amount of fresh water in the nth segment at high tide is given by the following relation:

$$f_n \cdot (P_n + V_n) = R / r_n \quad (3)$$

In our notation this is tantamount to the following determination of

$$f_n = R / P_n \quad (4)$$

This result is different from the results of any of the four examples of mixing processes given in Section 4.3. In order to illustrate these differences a very simple hypothetical example is worked out here.

Example. Consider an estuary which has segments $n = 0, 1, 2, 3$, but beyond these is connected to the sea. The segmentation is taken as being that of equation (1)

\sum	0	1	2	3	4	
V_n	1	2	2	3	Ocean	
P_n	2	3	5	7	Ocean	Table 4.31.1
u_n	0	1	3	5	8	

The method of Ketchum gives the following values of f_n by equation (4).

n	0	1	2	3	4	
f_n	1	1/2	1/2	1/3	0	Table 4.31.2

Mixing process 1 leads to the result that all values of $f_n = 1$

Mixing process 2 clearly is not applicable because the segments as given by equation (1) are clearly not of a size adequate for the limit to be reached. Mixing process 3 leads to the following values of f_n by equation (5)

n	0	1	2	3	4	
f_n	1	1/3	1/5	1/8	0	Table 4.31.3

Mixing process 4 leads to the following equation:

$$(V_n - V_0)(V_0 + R) f_{n-1} - (V_n - V_0 - R) V_0 f_n = R V_n \quad (5)$$

The value of f_3 must be determined by the equation

4.3.1, where $g'_4 = 0$

π	0	1	2	3	4	
$(V_n - V_0)(V_0 + R)$	0	3	9	15		
$V_0(V_n - V_0 - R)$	-2	0	4	8		Table 4.31.4
$R V_n$	2	3	5	7		
f_n	1	107/135	8/15	1/8		

By using these different hypotheses regarding the mixing process, the salinity distribution in the sample estuary is quite different. Had we used some method of segmentation other than Ketchum's, it would have been different from any of the above. For example, the mean f of the estuary by the tidal prism method is 1/8.

4.4 A mixing-length theory of tidal mixing (Arons and Stommel, 1951)

Consider an estuary of uniform width w , depth H , length L . The origin is placed at the river inflow where the salinity is maintained at $S = 0$. The x -axis is directed positively downstream. At the seaward end of the estuary, $x = L$, the salinity is maintained at that of the open ocean $S = \sigma$.

The river discharge is D (cu. ft/min). The mean velocity of water in the channel due to the river is therefore $u = D/wH$

If the length of the channel is small compared to a quarter tidal wave length, the tide will be simultaneous and uniform over the entire channel, and we may express the height of the tide as $\zeta = \zeta_0 \cos \omega t$, where ω is the angular frequency of the tide.

The tidal current U is obtained from the equation of continuity:

$$\partial \zeta / \partial t = -H \partial u / \partial x \quad (1)$$

$$U = U_0 \sin \omega t \quad (2)$$

where

$$U_0 = \zeta_0 \omega x / H \quad (3)$$

The average tidal displacement, ξ , is obtained by integration of the tidal velocity

$$\xi = \xi_0 \cos \omega t \quad (4)$$

where

$$\xi_0 = -s_0 x / H \quad (5)$$

We will consider the equation describing the mean salinity distribution:

$$\partial s / \partial t = u \partial s / \partial x = \partial (A \partial s / \partial x) / \partial x \quad (6)$$

In this equation S is the time mean salinity at any point x , u is the time mean velocity at x , which we may take as that portion of the flow due to the river (that is, $u = a$), and A is eddy diffusivity along the x -axis. We express A in terms of a dimensionless number B , a characteristic velocity which we take as the tidal amplitude U_0 , and a characteristic length which we take as $2 \xi_0$, the total excursion of a particle due to the tides

$$A = 2 B \xi_0 U_0 \quad (7)$$

This form of diffusion equation regards the tides as a turbulent motion superposed upon the steady river flow through the estuary. The simple assumed form of the eddy-diffusivity coefficient is the equivalent of Ketchum's assumption of the dimensions of the mixing volume. It should be clear to the reader that the simplicity of both of these formulations results from a certain vagueness about the physical process involved; the effects of stratification, stability, vertical mixing, bottom roughness, and other influences are not investigated.

In the steady state the time derivative vanishes, and (6) is integrable

$$as = A \partial s / dx + C \quad (8)$$

where C is a constant of integration. At $x=0$, both $S=0$ and $A ds/dx=0$, because there can be no transfer of salt up the river by eddy diffusion; thus the constant of integration $C=0$.

From (3), (5), and (7) we see that A may be expressed as a function of x

$$A = 2B\zeta_0^2 \omega x^2 / H^2 \quad (9)$$

It is convenient to introduce a dimensionless parameter

$$\lambda = x/L \quad (10)$$

to express the distance along the channel in fractions of the total length, and a dimensionless parameter

$$F = \frac{2H^2}{2B\gamma^2\omega L} \quad (11)$$

which we may call the "flushing number".

Making these various substitutions in (8) the following equation is obtained:

$$Fs = \lambda^2 ds/d\lambda$$

Integration by separation of variable yields the following expression:

$$\ln s = F/\lambda + C'$$

At $\lambda=1$, $s=\sigma$, so that the constant of integration C' is given by

$$C' = F + \ln \sigma$$

Therefore, it is possible to write the ratio of mean salinity to the ocean salinity in exponential form

$$s/\sigma = e^{F(1-1/\lambda)} \quad (12)$$

The family of curves on the relation λ to s/σ is shown in Figure 4.4.1 for the various values of the flushing number F .

Empirical data for both Alberni Inlet, Vancouver Island, and the Raritan River, New Jersey, are plotted on

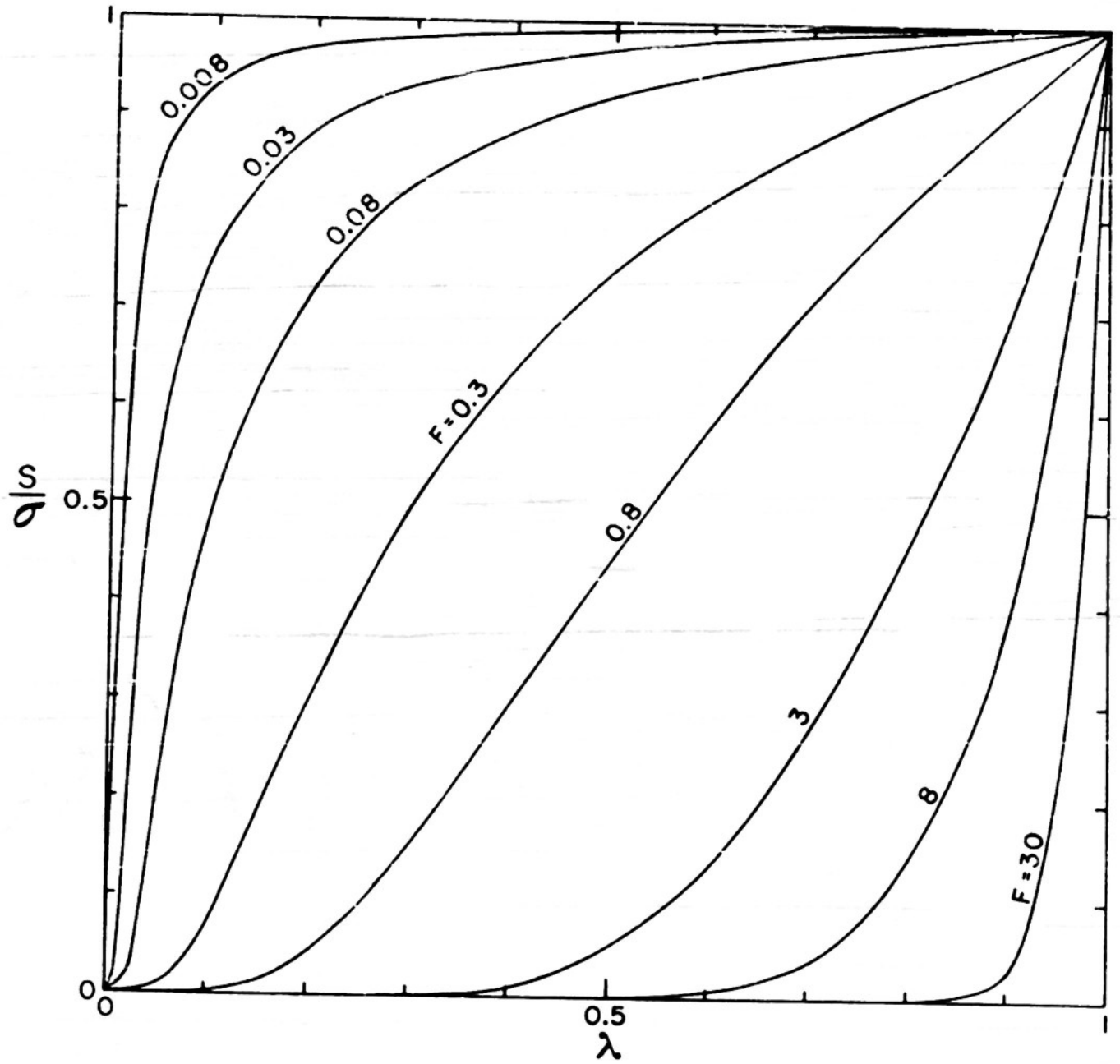

FIG. 4.4.1

this figure.

The family of curves is interesting for several reasons: (1) There is a toe to the curves near $\lambda = 0$. (2) The curves are very sensitive to F in region $0.1 < F < 10$. (3) There is a point of inflection at $\lambda = F/2$.

Convenient alternative forms of the flushing number are

$$F = \frac{DH^2}{2B\delta_0^2 \omega V} = \frac{DH^2 T}{4\pi B\delta_0^2 V} = \frac{RH^2}{4\pi B\delta_0^2}$$

where D is the river discharge, T is the tidal period, V is the mean total estuary volume, and R is the river discharge per tidal cycle.

The curves presented here were developed for a very much idealized situation. For that reason it is somewhat surprising and encouraging to find that empirical data from actual surveys can be plotted on the family with such good agreement.

An attempt to calculate the proportionality factor B from the data was unsuccessful, the values being of an order of magnitude different for the two cases. Therefore, it appears that although the shape of the theoretical curves is in good agreement with the observations at hand, an a priori calculation of the flushing number is not yet feasible. Nevertheless, the flushing number may be a convenient concept to characterize estuaries, just as the family of curves themselves is a convenient, semi-empirical expression of the mean salinity distribution.

If the mouth of the estuary is not taken as $\lambda = 1$ but some point λ_1 ($0 < \lambda_1 < 1$) further upstream is chosen as the end point, then the graph may still be drawn, but the flushing number is different. The salinity S_1 at λ_1 is given by

$$S_1/\sigma = e^{F(1 - \frac{1}{\lambda_1})}$$

If a new running variable $x = \frac{\lambda}{\lambda_1}$ is introduced

$$\frac{S}{S_1} = e^{\frac{F}{\lambda_1} \left(1 - \frac{1}{x}\right)}$$

The result of changing the location of the "mouth" is that the salinity distribution is still of the same family of curves, but with a different flushing number $F_1 = F/\lambda_1$.

4.41 Mixing in estuaries dominated by evaporation and precipitation.

Consider an idealized estuary as described in the previous section. If E is the evaporation from the surface in $\text{cm}/\text{sec}^{-1}$, the rate of change of salinity, S , will be given by:

$$S \frac{E}{H}$$

In the case of precipitation, E is negative.

A current is set up to compensate for the evaporated water

$$u = -Ex/H$$

The diffusion of salt is governed (as in equation 4.4.9) by a coefficient of eddy diffusion

$$A = kx^2$$

where

$$k = 2B\bar{s}'w/H^2$$

The steady state transfer of the salt transfer equation is given therefore by

$$k \frac{d}{dx} x^2 \frac{ds}{dx} + \frac{E}{H} x \frac{ds}{dx} + \frac{E}{H} s = 0$$

This may be simplified to the form

$$x^2 \frac{d^2 s}{dx^2} + ax \frac{ds}{dx} + bs = 0$$

where

$$a = 2 + \frac{E}{KH} \quad b = \frac{E}{KH}$$

This is a form of Euler's equation.

By substitution $s = x^\mu$ and eliminating the common factor x^μ we obtain the algebraic equation

$$\mu(\mu-1) + a\mu + b = 0$$

the roots of which are

$$\mu = -b, -1$$

The solution of the differential equation is then

$$s = C_1 x^{-1} + C_2 x^{-b}$$

The boundary conditions are that at $x = L$, $s = \sigma$ and also that the net salt flux vanishes, i.e. $S = \sigma$ and

$$v_s = A \frac{ds}{dx} \quad \text{at} \quad x = L$$

or

$$\sigma = C_1 L^{-1} + C_2 L^{-b}$$

$$b\sigma = \frac{E\sigma}{KH} = C_1 L^{-1} + b C_2 L^{-b}$$

Let

$$D_1 = C_1 L^{-1} \quad D_2 = C_2 L^{-b}$$

The equations which determine D_1 and D_2 are

$$\sigma = D_1 + D_2$$

$$b\sigma = D_1 + bD_2$$

from which we obtain $D_1 = 0$, $D_2 = \sigma$

The solution is

$$\frac{s}{\rho} = \lambda^{-b}$$

In Figure 4.4.2 this function is plotted against λ for various values of b . The quantity, b , plays the role of the flushing number F for estuaries whose salinity is governed by a balance between tidal flushing and evaporation.

$$b = \frac{EH}{4B\delta^2\omega}$$

Figure 4.4.3 shows the function plotted for negative E , that is, for precipitation.

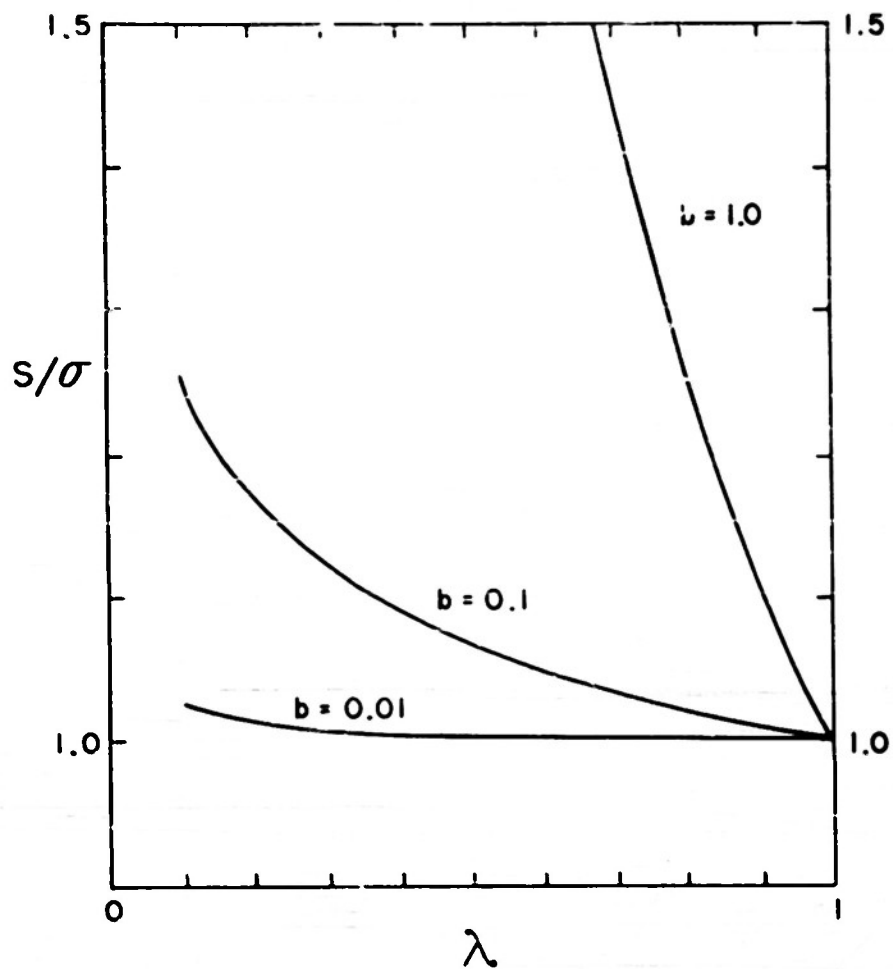

FIG. 4.4.2

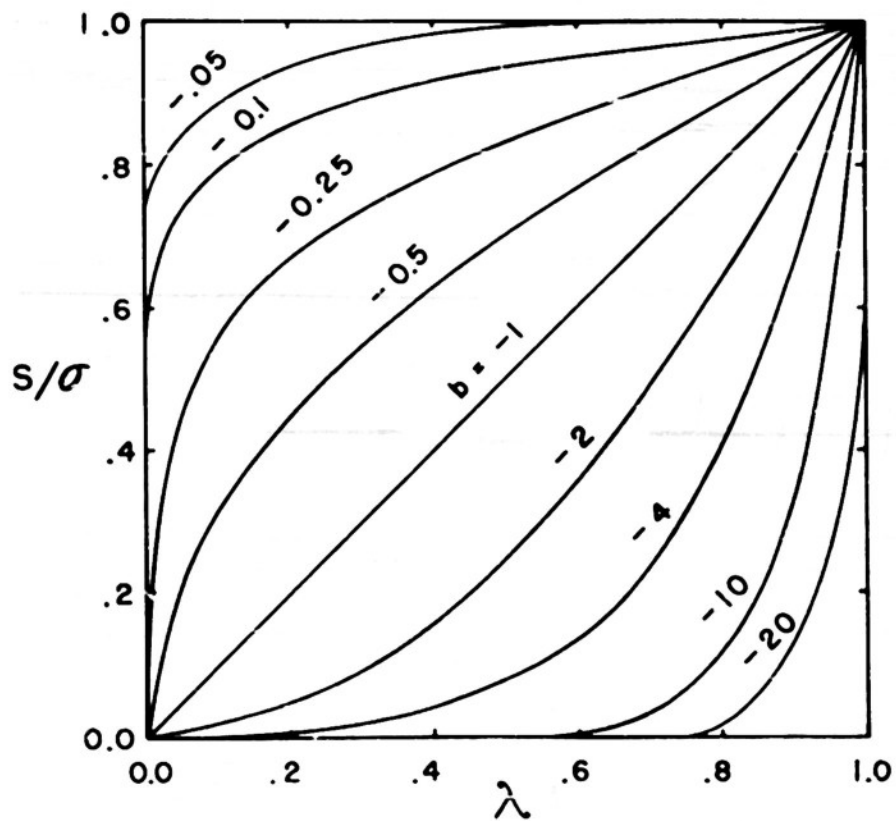

FIG. 4.4.3

4.42 Uniform mixing along an estuary

If the mixing in an estuary is not caused by the tides, but by the wind, for example, the eddy diffusivity A is not likely to be given by a quadratic law, but may be constant. Under these conditions the salt transfer equation is:

$$a \frac{ds}{dx} = A \frac{d^2s}{dx^2} \quad (1)$$

The boundary conditions are that at $x=L$, the mouth of the estuary, $s=s_0$ and

$$as = A \frac{ds}{dx} \quad (2)$$

The integral of this equation is:

$$\frac{s}{s_0} = e^{\frac{aL}{A}(\lambda-1)} \quad (3)$$

4.43 Mixing in a Pillsbury-type estuary

As shown in Section 6.5 there is a particular shape estuary in which the depth is constant, and the breadth is of an exponential shape in which the tidal velocity is independent of X , the position up and downstream. Many natural estuaries approximate this shape. It is of interest to extend the theory of tidal mixing curves of Section 4.4, which apply to a channel of uniform cross-section, to the special case of the Pillsbury-type estuary channel.

First of all, the eddy coefficient A is constant in a Pillsbury-type basin because both u and ξ are both independent of X

$$\xi_0 = 2u_0/w$$

Thus the relation given in equation (4.4.7) is changed to the following constant form:

$$A = 4B u_0^2 / w \quad (1)$$

The total flux of salt across a transverse section is given by

$$bh \left[as - A \frac{ds}{dx} \right] = 0 \quad (2)$$

where $b = b_0 e^{\frac{wx}{h} \left(\frac{\xi_s}{u_0} \right)}$ (see Section 6.5)

and the other quantities are defined in Section 4.4. The local non-tidal velocity a is given by $a = Q/bh$ where Q is the river discharge.

Equation (2) thus becomes

$$A \cdot bh \frac{ds}{dx} = Qs$$

This integrates directly to

$$\frac{s}{s_0} = e^{\frac{Q}{4B\omega_0 b_0 s_0} \left(1 - e^{-\frac{\omega s_0 x}{h\omega_0}}\right)} \quad (3)$$

This may be written in a form exactly the same as equation (4.4.12)

$$\frac{s}{s_0} = e^{F_1 \left(1 - \frac{1}{\lambda_1}\right)}$$

but in this case $\lambda_1 = b/b_0$ and

$$F_1 = \frac{Q}{4B\omega_0 b_0 s_0} = \frac{Qh}{4B\omega L_1 s_0^2 b_0} = \frac{.7Qh}{4B\omega L_1 s_0^2 b_0}$$

where L_1 is the distance upstream from the mouth where $b = b_0/e$ or L_1 is the distance upstream where $b = \frac{1}{2}b_0$.

Thus we may use the same family of curves as shown in Figure 4.4.1 for the Pillsbury-shaped channel, only F_1 and λ are redefined.

For a quick evaluation of the F_1 , it is convenient to locate the value of b/b_0 where s/s_0 has some given value, say, 0.5. Table 4.43.1 gives the value of F_1 for various values of λ , at $s/s_0 = 0.5$

TABLE 4.43.1

λ_1	F_1
0.9	6.3
0.8	2.8
0.7	1.6
0.6	1.04
0.5	.69
0.4	.46
0.3	.21
0.2	.17
0.1	.08
0.05	.037
0.02	.014
0.01	.007

4.44 Example of horizontal mixing theory: The Severn

The data available for the Severn Estuary (7.11) is adequate to test the various theories proposed in the previous sections. First of all, it is clear that the Severn is an unstratified Type 1 estuary, to which the ideas of horizontal mixing ought to apply, if they are correct. We will compute horizontal salinity distributions on the basis of Ketchum's Exchange Ratio, and on the basis of the Arons-Stommel theory. It will be shown that neither of these methods work for the Severn. The inference appears to be that the mixing length involved is not even remotely similar to the tidal displacement in the Severn, but is more nearly the depth.

The Severn by method of Section 4.31

The volume of water in the Severn Estuary was computed from the data given by Gibson (1933). Figure 4.44.1 shows the accumulated volume of water from Gloucester to seaward at high and low water during Spring tides. For March, 1940, the average river discharge (Figure 7.11.2) is 2,600 cusecs, which is equivalent to $1.2 \times 10^8 \text{ ft}^3$ /tidal cycle. The segmentation of the estuary is started by recalling the definition of the $n=0$ segment, $P_0 = R$, and, using equation (4.31.1) the subsequent P_n and V_n volumes may be readily determined. The following table summarizes the calculation:

TABLE 4.44.1

n	=	0	1	2	3	Ocean	
$P_n \times 10^{-3}$	=	1.2	89	910	-		ft ³
$V_n \times 10^{-3}$	=	2.2	3.3	92	1000		ft ³
$R/P_n = f_n$	=	1	0.01	0.001	-		
S_n ‰	=	0	32	32	-	32	
From Fig. 7.11.5 S_n ‰		0	8	16		32	

From the results through Segment 2 further calculation to the ocean is not warranted.

The freshness, f_n , and salinity, S_n , are the average values for the individual segments. For comparison, the salinities from Figure 7.11.5 during winter spring tides are given. It is evident that the salinities computed by the method of Section 4.31 are greatly in excess of those observed.

The Severn by method of Section 4.43

It is easy to see that Figure 7.11.5 may be plotted on a flushing number graph (Figure 4.4.1). When this is done it is found that B is of the order of magnitude of 10^{-3} , for both summer and winter. The tidal excursion is of the order of 150,000 feet in the Severn. The mixing length, therefore, is no more than 150 feet. As a result the hypothesis upon which Sections 4.4 to 4.44 is

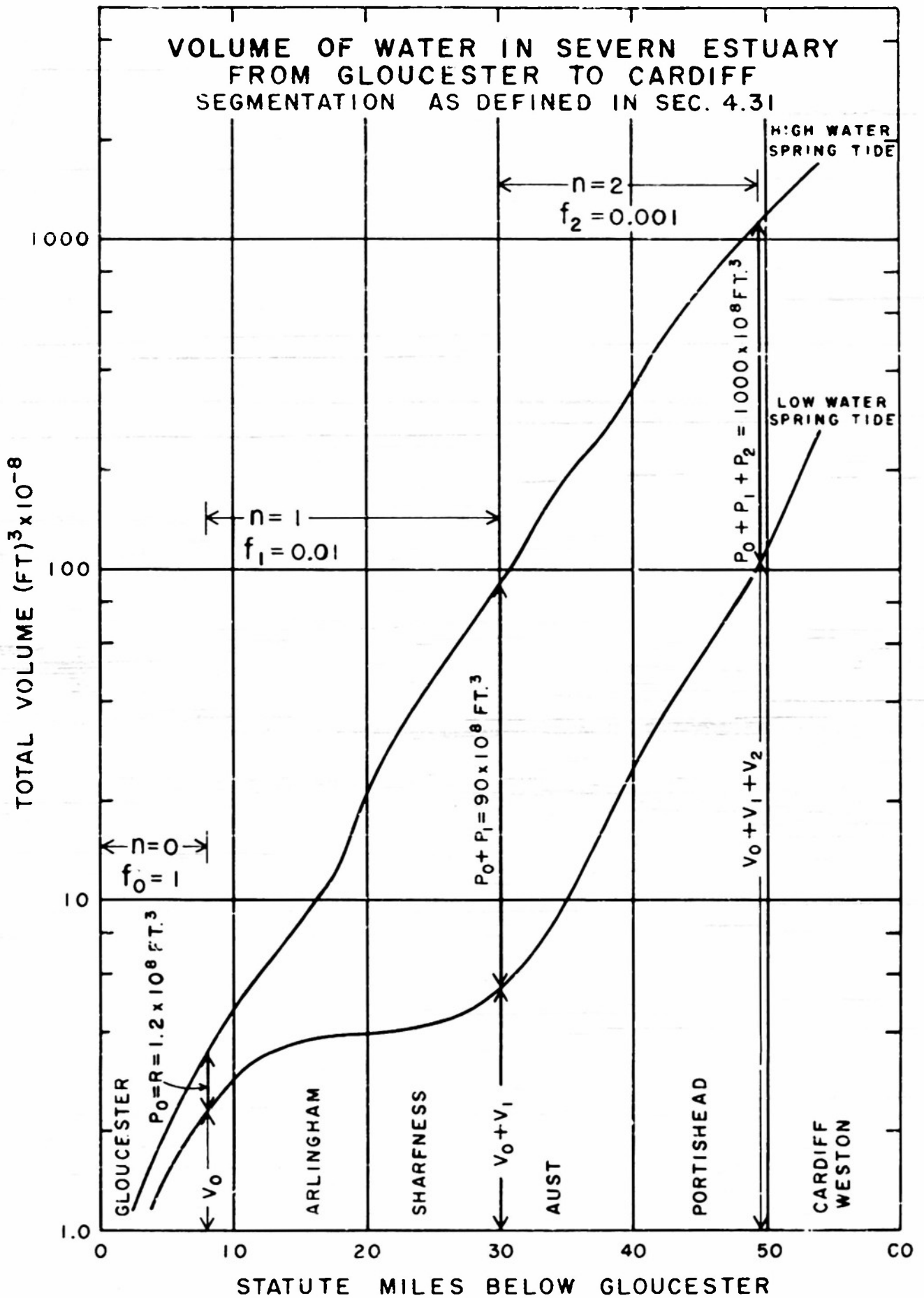

FIG. 4.44.1

based is simply not satisfied. The mixing length appears to be more certainly related to the depth. Upon reflection the reader will probably agree that this seems more reasonable anyway. Instead of the mixing being done by huge horizontal eddies, several miles in length, the mixing is done by small "boils" or eddies resulting from the shearing flow over the bottom. In order to demonstrate this fact more clearly we have considered the Severn in more detail.

The steady state distribution of salinity is a balance of diffusion and advection:

$$as = A \frac{ds}{dx}$$

where the x -axis is directed downstream, S is salinity, a is the mean river velocity, and A the coefficient of diffusivity. The quantity a at any x may be computed from the river discharge Q divided by the width w and depth d of the estuary:

$$a = Q / wd$$

The diffusivity A may be written as

$$A = B' d v$$

where v is the amplitude of the tidal velocity and d is the depth.

In this case

$$B' = (Qs) / (w v d^2 ds/dx)$$

We computed the value of B' at several points in the Severn from this formula.

TABLE 4.44.2

	<u>Weston</u>	<u>Portishead</u>	<u>Aust</u>	<u>Sharpness</u>	<u>Arlingham</u>
w (feet) $\times 10^3$	46.0	26.0	6.9	5.2	2.1
d (feet)	70	60	50	20	15
v (ft/sec)	8.5	8.5	8.5	8.5	8.0
<u>Winter</u>					
S (°/oo)	23	16	8	6	4
ds/dx (°/oo $\times 10^4$ /ft)	0.6	0.8	0.8	1.0	1.2
<u>Summer</u>					
S (°/oo)	28	27	25	20	18
ds/dx (/oo $\times 10^4$ /ft)	0.2	0.2	0.2	0.8	0.6
B' winter	0.6	0.7	1.5	9.0	5.0
B' summer	0.3	0.7	3.0	5.0	6.0
Winter Q ft ³ /sec	2600				
Summer Q ft ³ /sec	360				

The Raritan River

The Raritan River is the chief example given by Ketchum (1950) to illustrate the hypothesis of the exchange ratio. It is interesting to determine the mixing length at several stations similar to those discussed by him.

Station (1) 5 miles upstream of South Amboy

Station (2) South Amboy

Station (3) 3 miles downstream of South Amboy

The river discharge used by Ketchum is $33 \times 10^6 \text{ ft}^3 / 12.5$ hours, or $730 \text{ ft}^3 / \text{sec}$. The tidal velocity is about 1.5 knots, or 2.6 ft/sec.

	<u>Station 1</u>	<u>Station 2</u>	<u>Station 3</u>
Depth (ft.)	9	12	18
Width (ft.)	3600	7800	24,000
S ‰	10	25	26
<i>ds/dx</i> ‰/mi	4.4	0.4	0.2
<i>ds/dx</i> ‰/ft	0.7×10^{-3}	0.7×10^{-4}	0.3×10^{-4}
Mixing length in feet	128	1100	560

The mixing length is clearly much greater than the depth, but not as large as the tidal excursion.

The reader will see that whereas the mixing length in the Severn is of the order of magnitude of the depth, in the Raritan it is much larger, but not nearly as large as the tidal excursion.

4.45 Horizontal tidal exchange through an inlet.

A constricted inlet may be expected to act as an efficient tidal exchanger because of the tendency of the flow into it to be potential, whereas the flow out is jet-like, as indicated in Figure 4.45.1. As a result, one

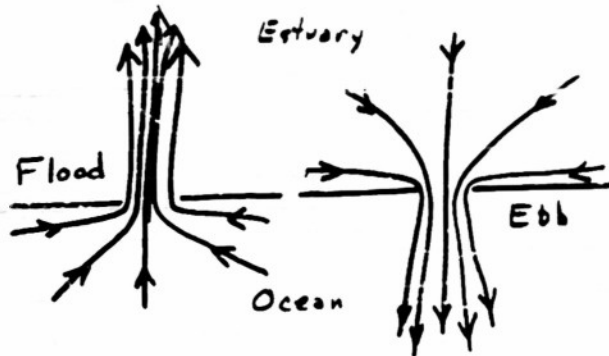

Figure 4.45.1

should expect that for the most part, the water passing through the inlet when the current reverses is not the same as that before reversal.

Let us consider the following simple theoretical picture: an inlet of width a (Figure 4.45.2). For simplicity we assume that

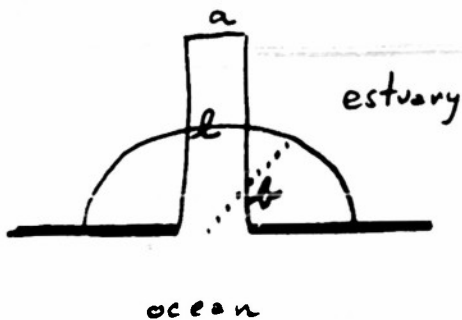

Figure 4.45.2

the depth D is uniform both in the inlet and throughout the estuary. The discharge on the ebb is from a semi-circular region of radius b , and amounts therefore to

$\frac{\pi}{2} b^2 D$. The flow during flood, which occurs in a jet-like filament of width a , and length l , amounts to $-ald$. The total river discharge for a complete tidal cycle is R , and for simplicity is written as $R = arD$

The conservation of mass requires that

$$\frac{\pi}{2} b^2 - al = ar \quad (1)$$

The conservation of salt requires that

$$a(b-l)\sigma + \left(\frac{\pi}{2} b^2 - ab\right) s = 0 \quad (2)$$

where s is the salinity inside the inlet and σ is the salinity of the ocean. The assumption involved is that on the ebb the portion of the jet ab within the semi-circle ebbs undiluted, but that the remainder of the ebb is water of salinity s . Elimination of l between equation (1) and (2) results in the following expression:

$$\frac{s}{\sigma} = 1 - \frac{\left(\frac{r}{b}\right)}{\frac{\pi}{2} \frac{b}{a} - 1}$$

4.46 Computation of pollution in a vertically mixed estuary by numerical process

As was seen in Section 4.44, there appears to be serious difficulty in applying to an estuary any of the hypothetical mixing processes discussed in the early sections of this Chapter. For example, the salinity distribution in the Severn estuary did not seem to fit properly that computed by the exchange ratio. The method of Section 4.44 is always open to the objection of the restrictive assumption about the geometry of the estuary and the undetermined nature of the constant B . From a practical point of view the proper procedure is to use the distribution of river water as a means of discovering the magnitude of the turbulent diffusion coefficients at various places in the estuary, and to devise a method using these coefficients which will yield the dilution of pollution at any point in the estuary. An attempt at such a method is described in the following. It is important to re-emphasize that it is intended to apply only to vertically unstratified estuaries in which the mixing is due to tides.

The steady state equations

Let us consider an estuary such as that shown in Figure 4.46.1. The X -axis is directed along the axis of the channel, the cross-sectional area $S(x)$ may vary with the position along the axis.

Now we will suppose that a pollutant, which is miscible with water, whose average (over a tide) concentration $c(x)$

varies with x , is in a steady state distribution in the estuary.

The term steady state means that the average of the concentration C over a tidal cycle does not change from tide to tide. This will be true if there has been little change in the river discharge during the time involved, and the discharge of pollutant into the estuary has remained constant. If the total river discharge into the estuary, at some point remote in the $-x$ direction, is Q , then the flux of pollutant by advection toward the sea is Qc .

In addition, there is a turbulent flux due to the tidally produced turbulence in the estuary. This turbulent flux may be written in the customary fashion: $-SA \frac{dc}{dx}$ where $A(x)$ is a turbulent eddy diffusivity, the value of which must be determined before the distribution of the pollutant can be calculated. Contrary to the methods of Ketchum, and of Arons and Stommel, we will not specify A a priori.

The net seaward flux $F(x)$ of pollutant across any section is the sum of these two fluxes.

$$F(x) = Qc - SA \frac{dc}{dx} \quad (1)$$

If the pollutant is conservative (does not decay with time), the net flux $F(x)$ must be constant downstream of the source of pollutant, and must be zero upstream of it. Some

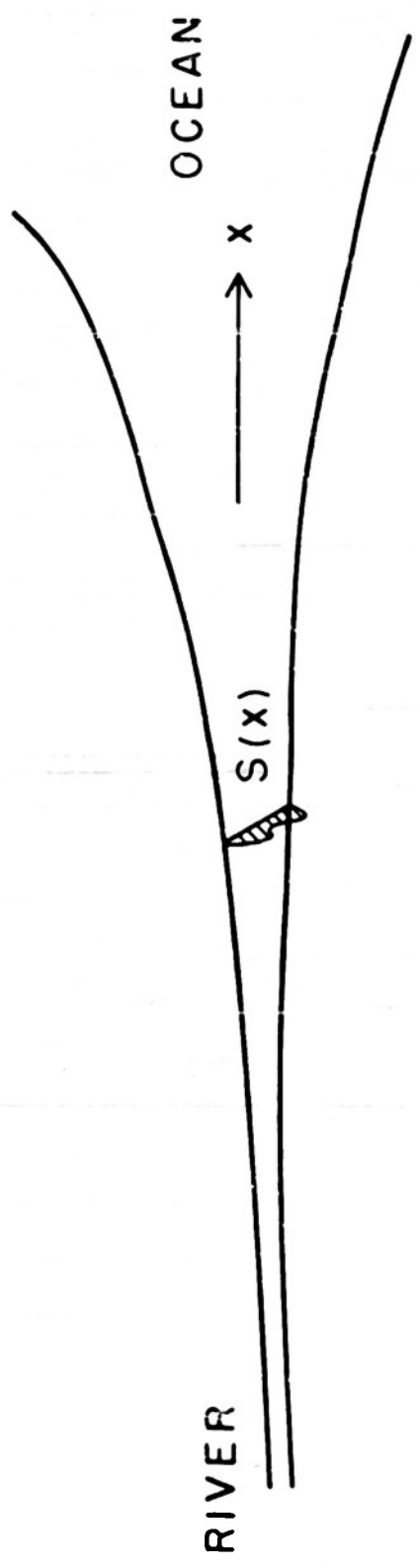

Figure 4.46.1

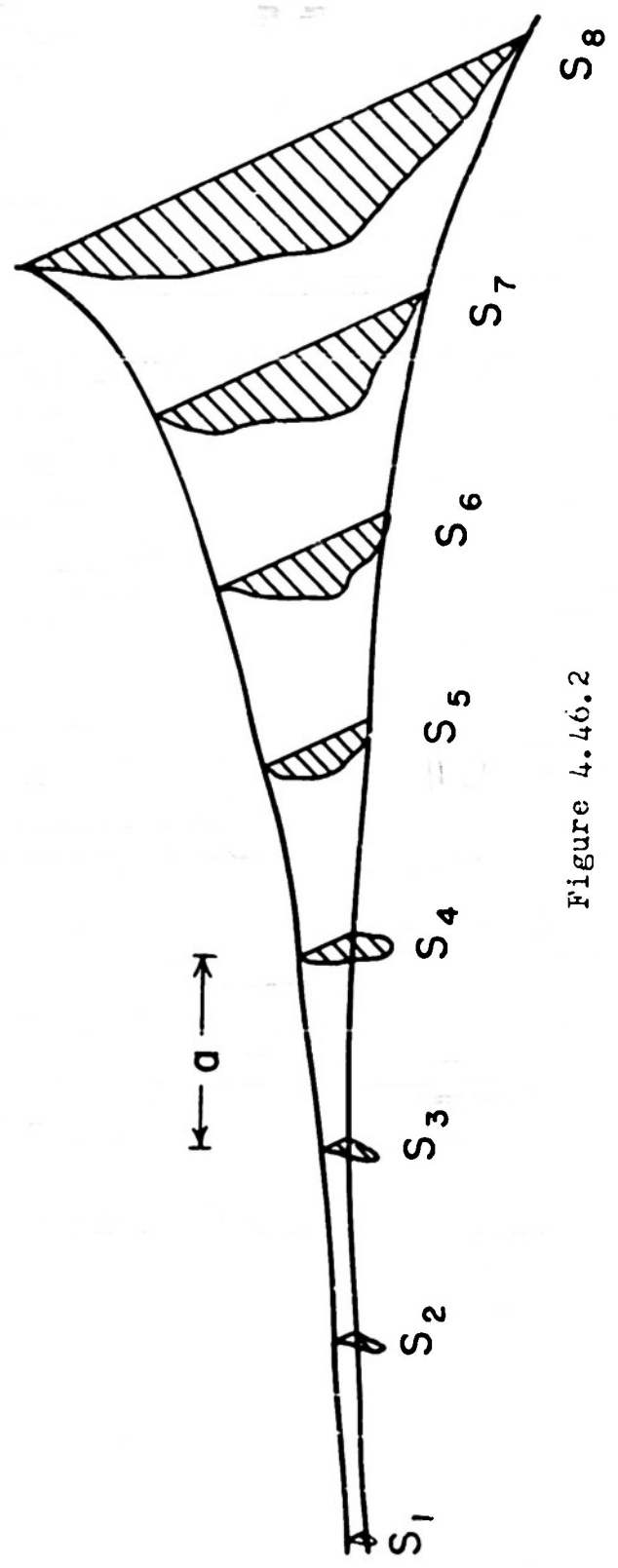

Figure 4.46.2

important pollutants, such as bacterial and atomic pile wastes, are not conservative, and their concentrations decay even when not subject to the dispersing influence of the estuary.

The concentration of such a non-conservative pollutant in an isolated container, may decrease with time according to the exponential decay law

$$C = C_0 e^{-t/\tau} \quad (2)$$

where τ is the time required for the concentration to decay from the concentration C_0 to $\frac{C_0}{e}$. The time, τ , is slightly larger than the half-life of the pollutant:

$$0.693 \tau = (\text{half life})$$

The net flux, $F(x)$, cannot be the same for all values of x if the pollutant is non-conservative, but must diminish in the following manner:

$$\frac{d}{dx} F(x) = -\frac{S}{\tau} C \quad (3)$$

The steady state equation (1) may be written in the following form:

$$\frac{d}{dx} \left[Qc - SA \frac{dc}{dx} \right] + \frac{S}{\tau} = 0 \quad (4)$$

$$= \psi \quad \text{at outfall}$$

where ψ is the total rate of pollutant supply at the outfall.

For a given pollutant and given estuary it is evident that the quantities Q , S , and Z are known. If we can determine A , then the distribution of $C(x)$ should be easily calculated.

Determination of the eddy diffusivity A

The eddy diffusivity A may be computed from a knowledge of the concentration of any other property in the estuary. The concentration of fresh water, $f(x)$, is a convenient conservative property. In some estuaries where ground-water, or precipitation, or evaporation, is important, it might be almost impossible to use the concentration of fresh water as a means of computing A .

Let us suppose for the immediate purpose that all the fresh water comes from one river, and that little is added or subtracted by other means. How to treat more complicated cases will be evident when the principles for this simple case are understood.

If the concentration of fresh water, f , is written for in equation (1) we obtain the following form of the equation, because in this case $F(x) = Q$

$$A = \frac{Q(f-1)}{S \, df/dx} \quad (5)$$

The concentration of fresh water, f , is dimensionless (e.g., pure fresh water is represented by 1.0; a mixture of one part fresh water, three parts sea water, is given by $f = 0.25$, etc.). The quantity, Q , (river discharge) has dimensions of ft^3/sec ; the cross-sectional area, ft^2 ; and distance in the X direction, ft . The dimensions of the eddy diffusivity A are therefore ft^2/sec .

The easiest way to compute A is to segment the estuary along its axis, the intervals being equally spaced a feet apart (Figure 4.46.2).

The average value of f is indicated at each segment. The equation (5) may now be written in finite difference form for numerical computation:

$$A_n = \frac{Q2a(1-f_n)}{S_n(f_{n-1} - f_{n+1})} \quad (6)$$

In general, f_n is less than unit, and f_{n+1} is less than f_{n-1} , so that A_n is expected to be positive. The values of A_n at points far upstream, (where $f_n \rightarrow 1$ and $f_{n-1} \rightarrow f_{n+1}$) are indeterminate from the fresh water distribution; this is also true beyond the mouth of the estuary in the ocean.

Calculation of the concentration of pollutant C

Equation (4) is written in finite difference form and the various coefficients gathered together

$$P_n c_{n-1} + Q_n c_n + R_n c_{n+1} = 0 \quad (7)$$

where we have defined

$$P_n = -\frac{1}{2a} \left[Q - \left(\frac{A_{n+1} S_{n+1} - A_{n-1} S_{n-1}}{2a} \right) \right] - \frac{A_n S_n}{a^2}$$

$$Q_n = \frac{2A_n S_n}{a^2} + \frac{s_n}{\tau}$$

$$R_n = \frac{1}{2a} \left[Q - \left(\frac{A_{n+1} S_{n+1} - A_{n-1} S_{n-1}}{2a} \right) \right] - \frac{A_n S_n}{a^2}$$

Equation (7) must hold at each of the segments, with one exception. In addition, there are certain additional constraints. At the ocean, where $f=0$, the value of $C=0$, and far upstream, $C=0$. At the segment where the outfall of the pollutant is located one further condition is imposed: the difference in flux upstream and downstream must be equal to the total rate of input of pollutant ψ . We may designate the segment at which the source (outfall) of pollutant is nearest as $n=S$.

In place of equation (7), which holds at all points except at $n=S$, we have

$$P_S C_{S-1} + Q_S C_S + R_S C_{S+1} = \frac{\psi}{2a} \quad (7')$$

The equations having been obtained, the solution is easily carried through by relaxation methods.

Simple example, estuary of uniform section

Before proceeding with a numerical example, it may be of interest to consider a simple example to illustrate certain fundamental properties of the problem. We will choose an example which admits an analytical solution.

Consider an estuary of uniform cross section S , which opens abruptly into the sea at $x=0$. If the eddy diffusivity A is a constant, then the concentration of fresh water has a very simple analytical form:

$$f = 1 - e^{x'} \quad (8)$$

where

$$x' = \frac{Q}{AS} x$$

The water is entirely fresh far upstream ($f=1$), but diminishes to $f=0$ at the mouth, as shown by the dashed line in Figure 4.46.3. In this graph the distance along the estuary is plotted in dimensionless units x' (x' is negative within the estuary).

Now consider the concentration of pollutant due to an outfall at $x=L$. The analytical solution of equation (4) is composed of two separate parts:

applies upstream of the outfall

applies downstream of the outfall

$$\frac{c_1(x)}{c(L)} = e^{k_1(x'-L')} \quad (9)$$

$$\frac{c_2(x)}{c(L)} = \frac{e^{k_2 x'} - e^{k_1 x'}}{e^{k_2 L'} - e^{k_1 L'}} \quad (9')$$

where

$$c(L) = c_0 \left(e^{k_2 L'} - e^{k_1 L'} \right)$$

and

$$k_1 = \frac{1}{2} \left(1 + \sqrt{1+Z} \right)$$

$$k_2 = \frac{1}{2} \left(1 - \sqrt{1+Z} \right)$$

and

$$Z = 4AS^2 / (\tau Q^2)$$

and

$$c_0 = \psi / Q ; L' = \frac{Q}{AS} L$$

The quantity c_0 is the concentration of pollution which would result at the outfall if there were no diffusion or decay, in other words, the simple dilution by river flow alone.

Fig. 4.46.3 displays certain of these solutions. The abscissa is expressed in a dimensionless fashion. The ocean is located at the extreme right-hand side. Toward

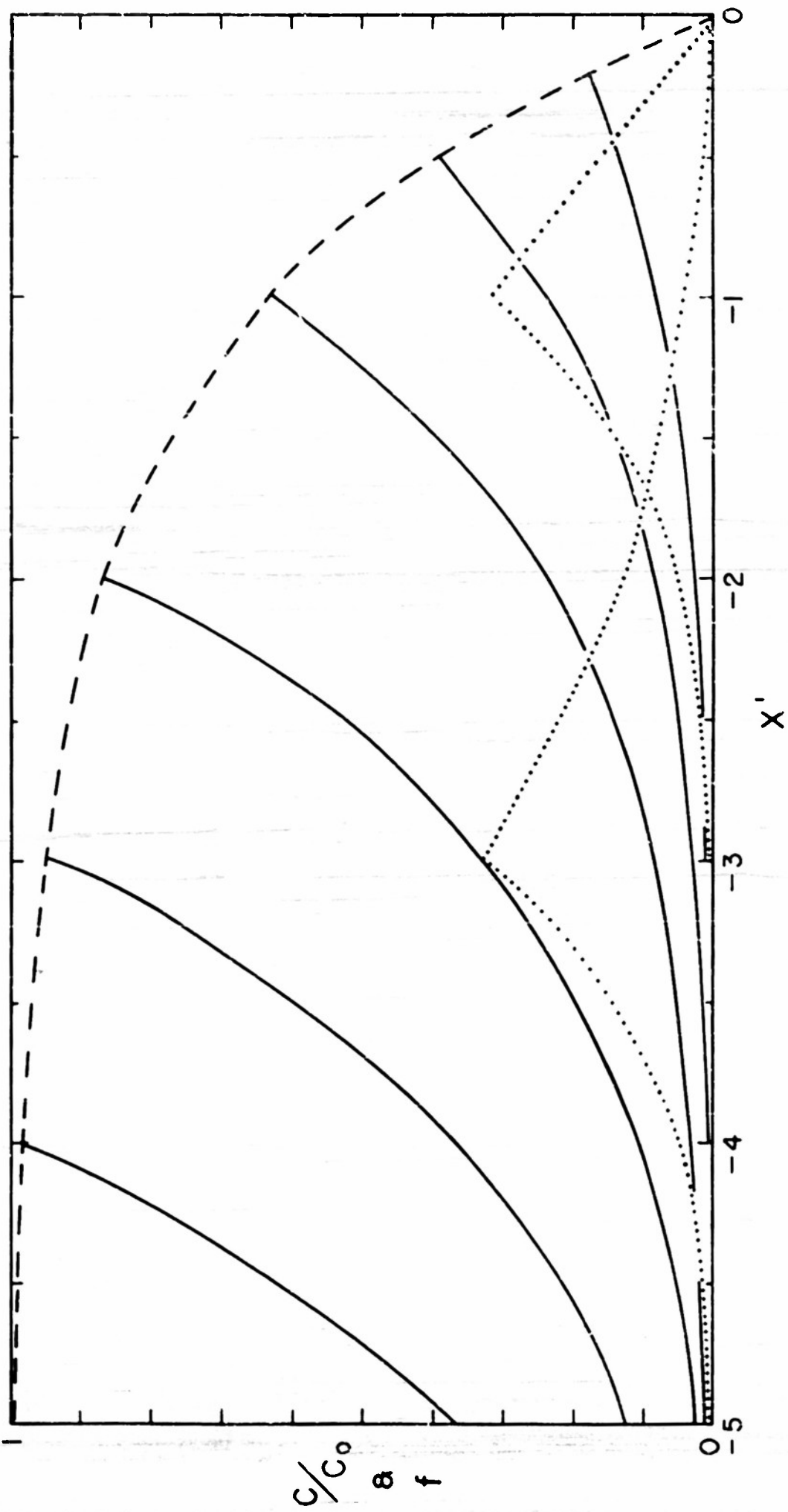

Figure 4.46.3

the left is the upstream direction. The dashed line is the solution of the equation for the concentration of fresh river water, f , (equation 8). The solutions of the problem of the distribution of a conservative pollutant introduced at

$$x' = -4, -3, -2, -1, -0.5, -0.2$$

are shown as solid black curves, terminating at the dashed curve at each of the outfall locations respectively. The remainder of the solution (downstream of the outfall) falls along the dashed line. The peak concentration is at the outfall. It is immediately clear, then, in this simple case of an estuary of uniform cross-section and eddy-diffusivity, that the pollution extends far upstream of the outfall, no matter what the location of the outfall, but that the concentration is everywhere reduced upstream of the outfall if the location of the outfall is moved toward the sea.

A seaward displacement of the outfall also reduces the peak concentration at the outfall, but downstream the concentration of a conservative pollutant is not affected by such a displacement.

The dotted curves in Figure 4.46.3 represent solutions for a non-conservative pollutant whose decay time

$$z = AS^2 / (2Q^2)$$

for outfall locations at $x' = -3$ and -1 . The remarkable feature of these curves is that the peak concentration, even

at the outfalls, is much reduced from what it is in the case of the conservative pollutant. The general equation for the peak concentration is as follows:

$$\frac{c(L)}{c_0} = \frac{1}{\sqrt{1+z}} \left(1 - e^{-L\sqrt{1+z}} \right) \quad (10)$$

The non-conservative pollutant extends both up and downstream of the outfall, but, unlike the conservative pollutant, can be reduced at a point below the outfall by an upstream displacement of the outfall.

Consideration of this simple case also shows clearly the effect of a change in the river discharge Q . Increase of river discharge increases the fresh water concentration at every position, foreshortens the extent of pollution upstream, reduces the peak concentration of pollution at the outfall, and even reduces the concentration of a conservative pollutant downstream.

Numerical example

As an example of computation of concentration of pollution by numerical methods, a particular distribution is computed for the Severn estuary, for which there is good salinity data available (Bassindale, 1943). Stations are chosen beginning at Gloucester ($n=0$); the sections are spaced about two miles apart ($a = 10,000$ feet). Cross-section areas are given in Table 4.46.1, in the column headed S_n . The fresh water concentration, f_n , from actual summer time survey data, is also tabulated.

The eddy diffusivity, A_n , is computed at each station by equation (6) using a value of $Q = 360 \text{ ft}^3/\text{sec}$ as the fresh water discharge during the summer dry period. It is interesting to note that the highest values of A_n occur at stations 6, 7 and 8, which happen to be the location of the Severn bore.

Suppose now that a pollutant outfall is located at Sharpness ($m = 12$), and that this pollutant has a half life of 4 days ($\tau = 5 \times 10^5 \text{ sec}$). The coefficients P_n, Q_n, R_n , of equation (7) are tabulated in Table 4.46.1. An estimated distribution of pollutant is initially entered into the Table, and the sum X_n (called the residual) is formed:

$$P_n c_{n-1} + Q_n c_n + R_n c_{n+1} = X_n \quad (11)$$

Equation (7) requires that all residuals except that at the outfall should vanish. In fact, we see that this is far from true for the estimated pollution distribution. We can adjust the values of c_n by successive steps (relaxation method of Southwell, 1945) because it is obvious that if we add Δc_n units to any c_n not only will the residual X_n be changed by the addition of $Q_n \Delta c_n$ but also the residual X_{n+1} will be increased by $P_{n+1} \Delta c_n$ and the residual X_{n-1} by $R_{n-1} \Delta c_n$. We make these adjustments step by step, removing the worst residuals first, and from time to time re-computing the residuals from the newly

adjusted C_n by equation (11). When the residuals have all been reduced to a point where further readjustments of C_n are below the precision of the required result (say 1% to 5%) the relaxation procedure may be regarded as completed: namely, we have obtained a set of values of C_n which satisfy equation (7). In the example shown, 54 adjustments of C_n were necessary in all. The computation took about three hours. We have used arbitrary units for C_n and must now convert to units of actual pollution concentration. We may suppose that the discharge of pollutant at station 12 is 10 lbs/sec. The concentration due to dilution by a river flow of 360 ft³/sec alone (if there were no diffusion or decay) would be, therefore, 28×10^{-3} lbs/ft³.

The values of $\bar{\psi}$ (= 10 lbs/sec) is put into equation (7'), $\bar{\psi}/2a$ should then be equal to the residual \bar{X}_s . If all the concentrations in arbitrary units are multiplied by 5×10^{-6} the value of \bar{X}_s comes out properly. The values of the concentration of pollution thus computed are shown in the last column of Table 4.46.1.

Table 4.46.1

Numerical example of pollution computation

n	S_n 10^3 ft^2	f_n	A_n ft^2/sec	P_n	Q_n	R_n	C_n arbitrary units	X_n	C lb_m/ft^3 $\times 10^4$
0	7.7	1.000	--	-0.147	.062	0.100	0	0.0	0
1	7.7	1.000	--	-0.134	.099	0.080	1	+0.1	.05
2	8.9	.929	180	-0.182	.184	0.029	2	-0.1	.1
3	8.2	.840	280	-0.237	.296	-0.032	4	0.0	.2
4	12.8	.679	290	-0.282	.410	-0.191	13	+0.7	.6
5	15.4	.536	960	-0.377	.601	-0.169	44	+95.9	2.2
6	14.0	.465	1040	-0.419	.735	-0.192	100	-0.4	5.0
7	18.0	.393	1000	-0.384	.781	-0.406	48	-0.4	2.4
8	27.3	.350	390	-0.464	1.024	-0.541	21	0.0	1.1
9	75.0	.308	280	-0.793	1.567	-0.283	8	0.0	.4
10	102.0	.265	510	-0.496	1.487	-0.406	1.5	0.0	.07
11	64.0	.215	570	-0.572	1.767	-0.541	.7	0.0	.03
12	117.0	.200	270	-0.656	2.378	-1.283	.5	0.0	.02
13	151.0	.172	192	-0.274	7.123	-3.550			
14	254.0	.125	210	-2.714	7.035	-2.576			
15	265.0	.108	190	-2.937	6.498	-2.321			
16	410.0	.072	280	-2.468	8.618	-3.290			
17	524.0	.065	295	-3.147	9.188	-2.079			
18	525.0	.061	234	-3.139	7.357	-1.956			
19	655.0	.059	190	-2.218	7.341	-1.682			
20	1091.0	.046	110	-1.942	8.073	-1.855			
21	1372.0	.043	95	-2.078					
22	1263.0	.036	60						
23	1748.0	.029							
24	2070.0	.018							
25	2496.0	.011							
26	2915.0	.000							

4.51 The effect of controls on the limitation of mixing:
"overmixing".

There is a curious way in which a control acts to limit the possible amount of mixture. Consider an estuary E opening into the ocean (without tides) O through a transition T . If the entire system is sufficiently deep, and the

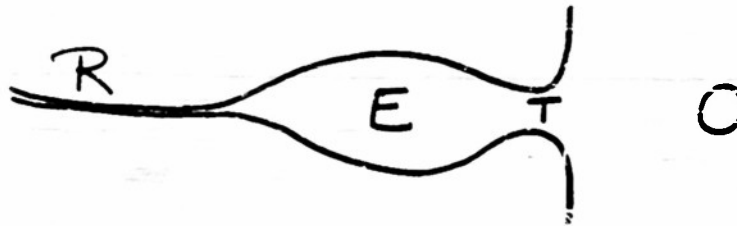

river R discharge (q , per unit width of the transition) is not too great, there is a two layer flow through the transition. The depth of the upper layer is determined by the method of Section 2.21. If there is no mixing between the two fluids, the lower layer is stagnant, and the upper layer at T is entirely fresh.

Suppose that some agency for vertical mixing of the two layers exists in the estuary E and that the amount of mixing is progressively increased. The upper layer is now somewhat brackish, the discharge of both layers through T is increased, and the interface nearer to mid-depth. Increased mixing in E decreases the salinity difference of the two layers at T , and increases the discharge; but there is a point beyond which increased mixing has no further effect on either the discharges through or the salinities at T .

It is natural to suppose that some estuaries will be over-mixed in this sense, and that the salinity control

will be exercised by the nature of the transition rather than by diffusion, horizontal, vertical, or otherwise.

The criterion for "overmixing" can be obtained from the equation for a stationary interfacial wave (2.21.9'):

$$\frac{\rho_2^2}{(1-\gamma)^3} + \frac{\alpha \rho_1^2}{\gamma^3} = \rho_1 \rho_2 \alpha^3 \quad (1)$$

the equation of continuity

$$\rho_1 + \rho_2 = \rho_0 \quad (2)$$

and the equation for the conservation of salt,

$$\rho_1 s_1 + \rho_2 s_2 = 0 \quad (3)$$

To relate salinity and density we may take a simplified equation of state

$$\rho = 1 + \alpha s \quad (4)$$

Thus

$$\beta = \frac{\rho_2 - \rho_1}{\rho_2} \approx \alpha (s_2 - s_1) \quad (5)$$

$$\alpha = \frac{\rho_1}{\rho_2} \approx 1 - \alpha (s_2 - s_1) \quad (6)$$

The equation (1) may now be written in the following form

$$g_1^2 \left[\frac{\left(\frac{s_1}{s_2}\right)^2}{(1-\eta)^3} + \frac{1 - a(s_2 - s_1)}{\eta^3} \right] = g a(s_2 - s_1) D^3 \quad (7)$$

or

$$\left[\frac{\left(\frac{s_1}{s_2}\right)^2}{(1-\eta)^3} + \frac{1 - a a_1 \left(1 - \frac{s_1}{s_2}\right)}{\eta^3} \right] = \frac{3 a a_1}{g_1^2} \left(1 - \frac{s_1}{s_2}\right)^3 D^3 \quad (8)$$

It is convenient to introduce $v = s_1/s_2$; $l = g a s_2 D^3 / g_1^2$

$$\phi(\eta) = v^2 \eta^3 + (1-\eta)^3 - l(1-v)^3 \eta^3 (1-\eta)^3 = 0 \quad (9)$$

This is an approximation of equation (8).

The real roots of $\phi(\eta) = 0$ between $\eta = 0$ and $\eta = 1$ cease to exist as $v \rightarrow 1$ and this point determines the state of overmixing. The value of η at which there is a double root occurs when

$$\frac{\partial \phi}{\partial \eta} = 0 = 3 \left\{ v^2 \eta^2 - (1-\eta)^2 - l(1-v)^3 (1-\eta)^2 \eta^2 (1-2\eta) \right\} \quad (10)$$

If we multiply equation (10) by η and subtract from (9) we obtain

$$l(1-v)^3 \eta^4 = 1 \quad (11)$$

Solving (11) for γ and substituting into (9) yields

$$\left(1 - \frac{1}{\gamma(\gamma l)^{1/3}}\right) \gamma^4 - (1-\gamma)^4 = 0 \quad (12)$$

This can be conveniently rearranged in the form

$$\gamma^8 = l (\gamma^4 - (1-\gamma)^4)^3 \quad (13)$$

As $l \rightarrow \infty$, $\gamma \rightarrow \frac{1}{2}$. This means that for weak river flows in estuaries with large transitions the overmixing leads to an interface at half depth. In order to investigate approximately the effect of $l < \infty$ we introduce $\epsilon = \gamma - \frac{1}{2}$; ϵ is a small quantity as long as l is large. Substituting this into equation (13) and retaining only the large terms we obtain

$$256 l \epsilon^3 - 16 \epsilon - 1 = 0 \quad (14)$$

For large values of l the roots of this expression are approximately

$$\epsilon = \sqrt[3]{1/(256l)} \quad (15)$$

In this way we can evaluate in states of overmixing at what values of l the quantity γ deviates significantly from $1/2$. The ratio of salinities of the

upper and lower layers, ν , is given by

$$\begin{aligned}\nu &= 1 - \frac{1}{\sqrt[3]{\ell \gamma^4}} \\ &= 1 - \frac{2}{\sqrt[3]{\frac{1}{2} \ell (1+8\epsilon)}}\end{aligned}$$

4.52 Experimental study of overmixing

Two sets of runs were made past a transition to test the theory of overmixing. The transition was a narrow segment of width W_1 opening to full width of the channel both upstream and downstream. The length of the narrow section was 42 cm in series G, and 100 cm in series H. Sample runs are summarized in Table 4.52.1 and Figure 4.52.1. In all runs the total depth D was 31.5 cm, g_0 is the river discharge per unit width of the transition. ρ_0 is the density of river discharge; ρ_1 the density of the overmixture; ρ_2 the density of the sea-water. ν is defined as

$$\nu = \frac{\rho_1 - \rho_0}{\rho_2 - \rho_0}$$

and ν_c is computed from the theory of Section 4.51. The data is plotted in Figure 4.52.1, the circles are G runs; the triangles are H series; the square is the only run (G-6) where ϵ is of sensible order of magnitude.

TABLE 4.52.1

Overmixing experimental runs

Run	D_0 cm ² /sec	W_1 cm	ρ_0	ρ_1	ρ_2	ν	ν_c
G-1	43.5	8.7	1.0170	1.0213	1.0259	.48	.50
-3	14.5	8.7	1.0170	1.0233	1.0259	.71	.77
-4	14.5	8.7	1.0000	1.0214	1.0259	.81	.82
-5	1.5	8.7	1.0000	1.0243	1.0259	.94	.95
-6	145.0	8.7	1.0000	1.0097	1.0259	.37	.36
-7	0.7	17.7	1.0000	1.0247	1.0259	.93	.97
-8	7.1	17.7	1.0000	1.0229	1.0255	.66	.90
-9	43.0	17.7	1.0000	1.0171	1.0255	.66	.67
-10	7.1	17.7	1.0170	1.0239	1.0255	.78	.85
-11	43.0	17.7	1.0170	1.0212	1.0255	.50	.52
H-1	0.7	17.5	1.0000	1.0240	1.0248	.97	.97
-2	7.1	17.5	1.0000	1.0221	1.0248	.88	.90
-3	71.0	17.5	1.0000	1.0140	1.0248	.56	.57
-4	0.5	27.8	1.0000	1.0248	1.0250	.99	.98
-5	4.6	27.2	1.0000	1.0230	1.0250	.92	.92
-6	46.0	27.2	1.0000	1.0160	1.0250	.64	.65

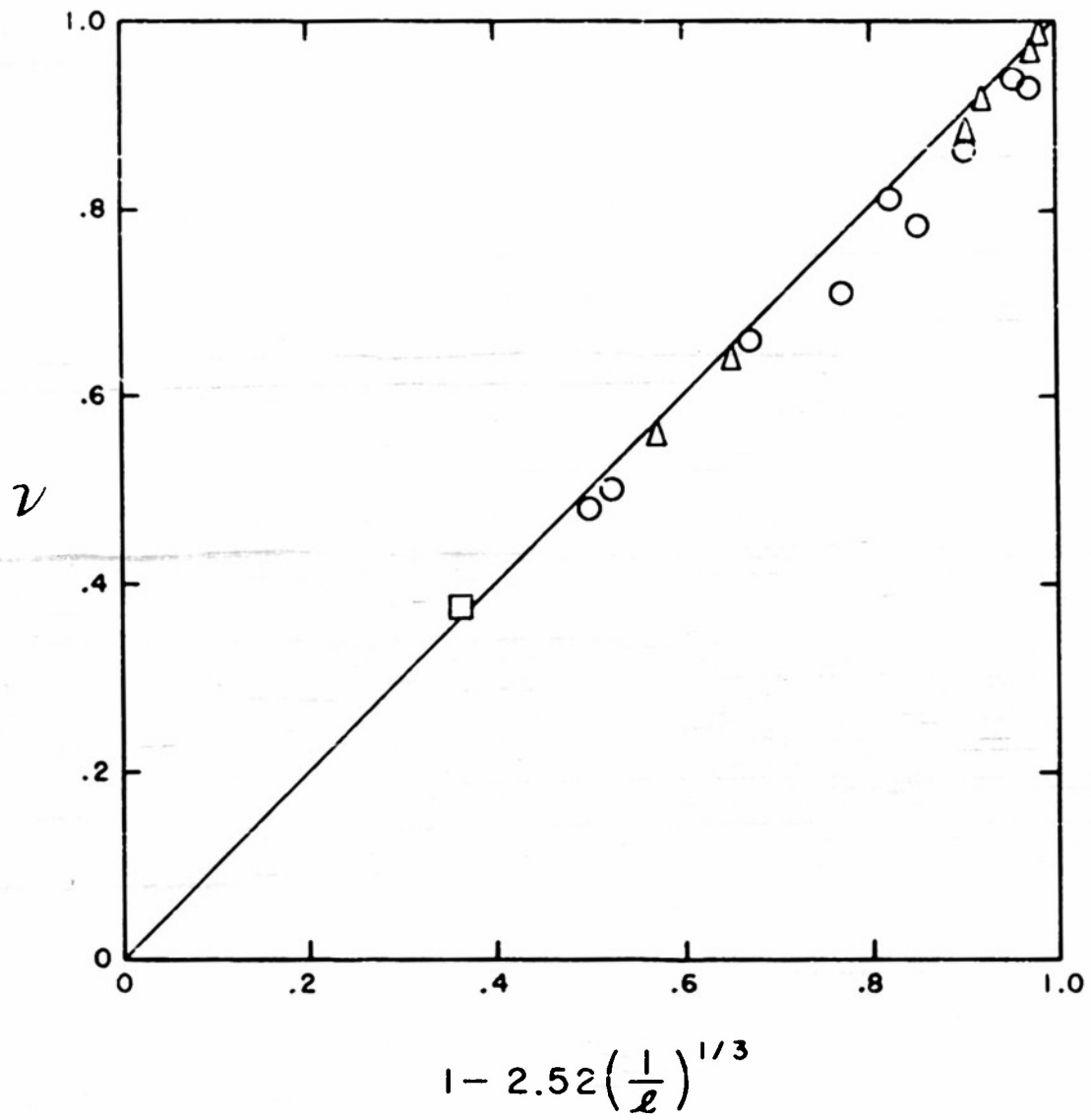

FIGURE 4.52.1

4.53 Influence of tidal currents on overmixing

Four tests were made in which a tide was imposed on the overmixed condition. Figure 4.53.1 shows the result of these experiments. In test 2, with the two minute tidal period, and test 3, the sea water of density ρ_1 is swept out of the transition for a portion of the tidal cycle and there is a reversal of flow in the upper layer. It is evident that serious disagreement in the ρ_1 of the steady and unsteady state tests is not experienced until test 4. In this test the surface profile was distorted by a bore and there was no vertical stratification.

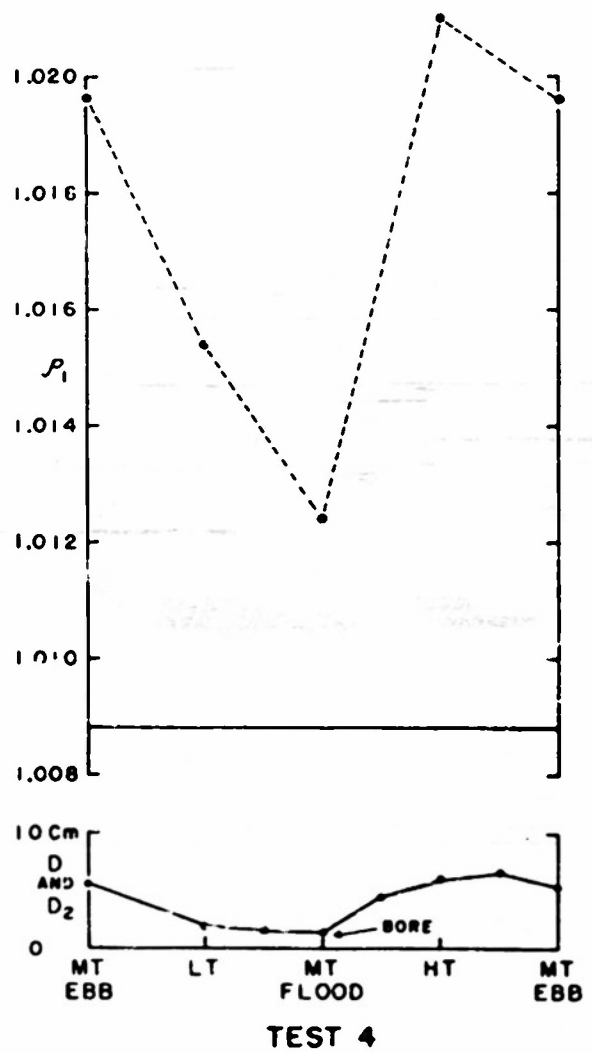
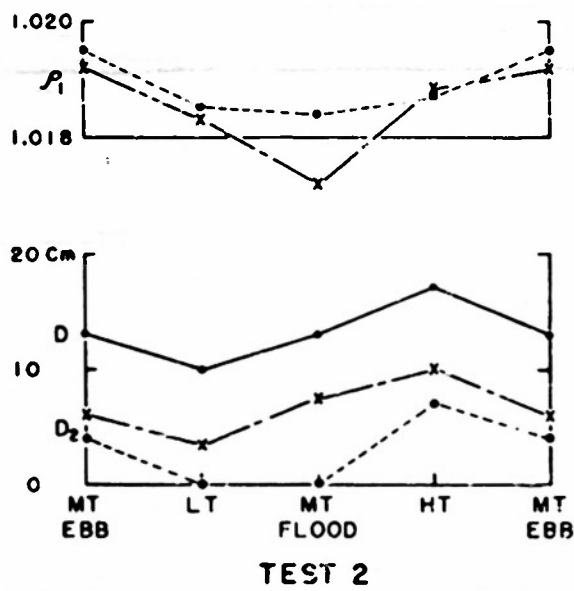
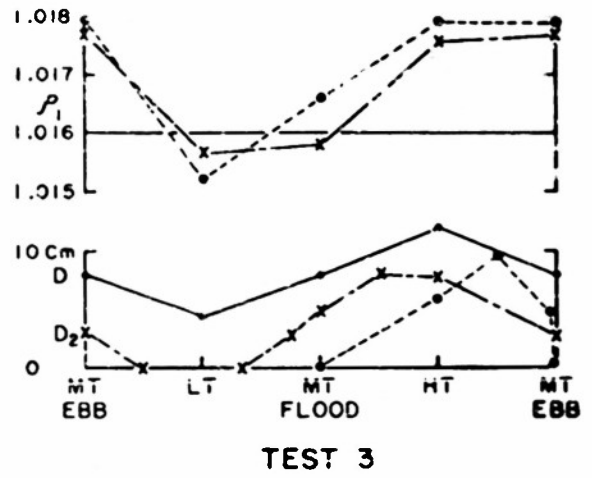
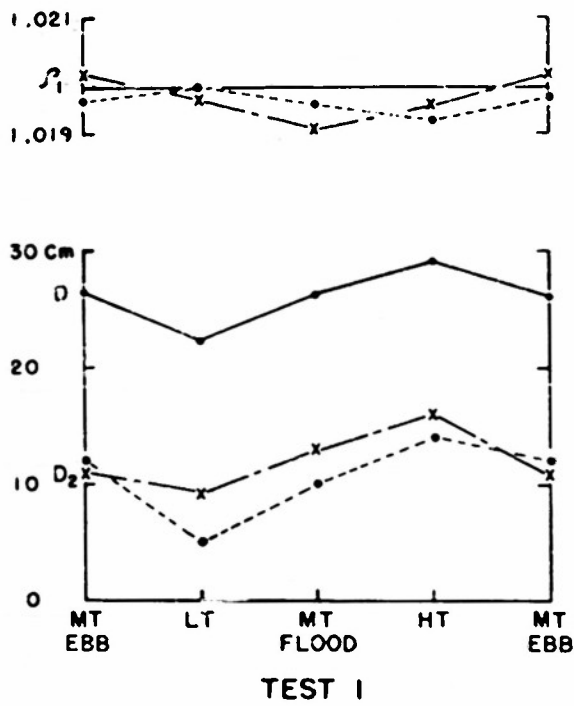

FIG. 4.53.1

4.54 Overmixing in actual estuaries

The only type of estuaries to which the concept of overmixing can properly be applied are those which are vertically stratified and in which there is evidence of a net flow (averaged over a tidal cycle, downstream in the upper layer, and a net upstream flow in the bottom layer. It is important not to attempt to apply this hydraulic condition to vertically mixed estuaries, such as the Raritan River, Delaware Bay, Bristol Channel-Severn estuary, where it does not appear that there is any hydraulic control action at the mouth.

Not all vertically stratified estuaries are likely to be overmixed. Rather obvious examples are Alberni Inlet, which is too deep to be thoroughly mixed by tides, and the Mississippi River passes, in which the tidal action is too small. However, in estuaries where there are tides of several feet or more, and the depth is not more than about ten meters, it is reasonable to suppose that overmixing may occur: that is, the salinity of the estuary upstream of a transition is determined by the control or "throttling" action of the transition on the two layer flow through it, and not by the magnitude of large scale horizontal turbulent exchange in the sense of Ketchum (1951) and Arons-Stommel (1951).

Hachey (1939) has summarized the data available on the salinity of the upper layer in St. Johns Harbor, (New Brunswick, Canada). The difference of salinity of the upper

and lower layers is plotted as a function of river discharge in Figure 4.54.1. The straight line is computed from equation (4.51.11) on the supposition that the abrupt widening at the mouth of the harbor acts as a control, that the width of the channel is 2,000 feet, the depth of the water is 30 feet, and that the mixing action of the reversing falls upstream is so efficient that overmixing occurs. Considering the crude nature of both the theory and data, the agreement is fairly good, and the conclusion is that the St. Johns harbor is overmixed.

Data on the dependence of stratification at the mouth of an estuary upon the river discharge is difficult to find in the literature. Very fragmentary data suggest that the following estuaries may be overmixed:

St. Johns River, Jacksonville, Fla.
Columbia River, Oregon
Savannah River, South Carolina
New Waterway, Holland
New York Harbor, N. Y.

It is suggested that in future surveys of estuaries where the possibility of overmixing exists, considerable detailed survey work be done on sections likely to exert control action. The observations should give vertical salinity and temperature soundings over a complete tidal cycle for several different stages of river discharge throughout the year. Construction of a graph, such as shown in Figure 4.54.1 will immediately determine whether or not the condition of overmixing exists in a particular estuary.

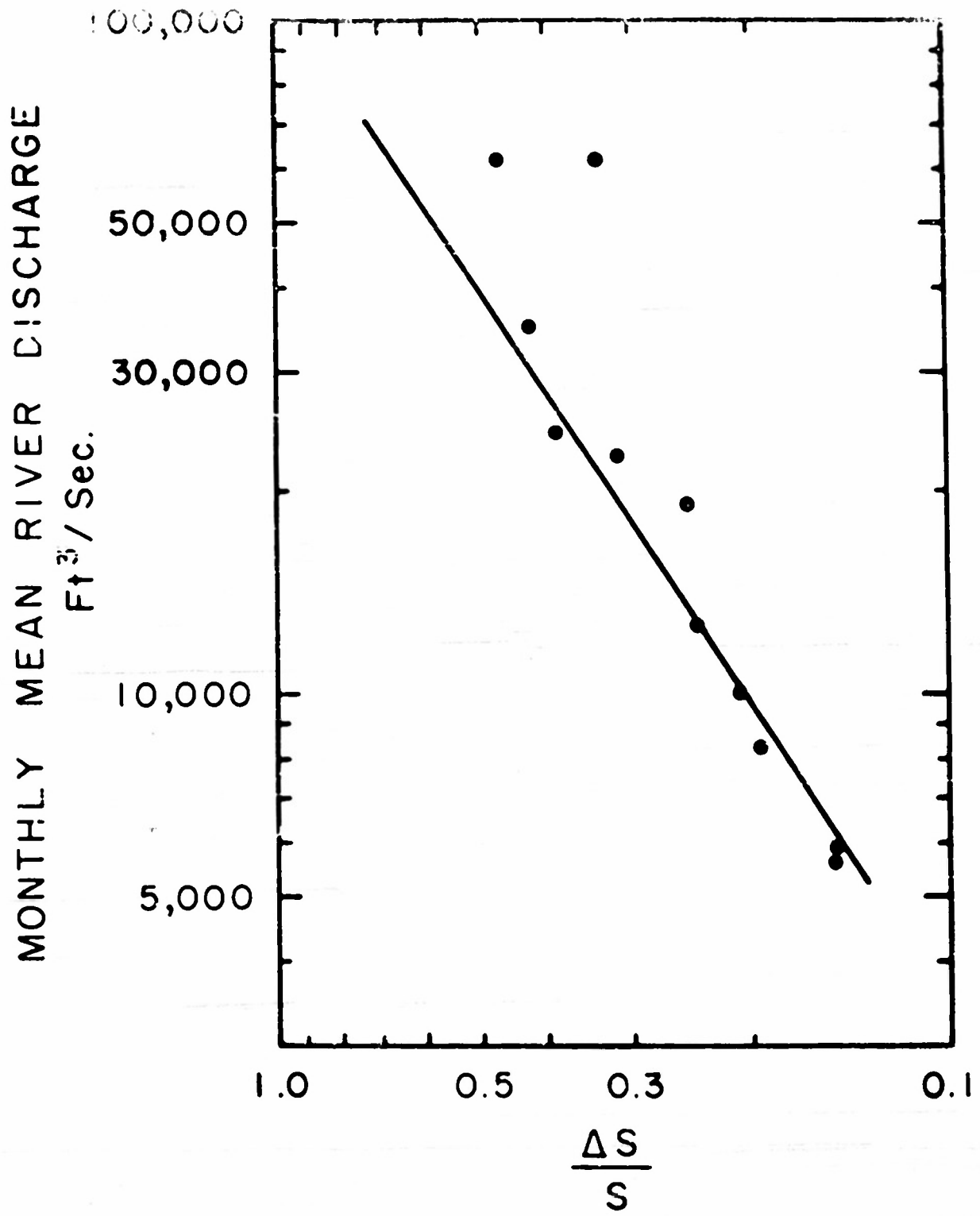

FIG. 4.54.1

4.6 Salinity distribution in the Type 2 estuary

Let S_1 and S_2 denote the salinity of the top and bottom layers respectively; g_1 and g_2 denote the discharges per unit width; w_m be the vertical entrainment velocity through the interface; and K the coefficient of turbulent exchange. The equations of salt conservation may be written

$$\begin{aligned} \frac{d}{dx}(g_1 s_1) &= w_m s_2 - K(s_1 - s_2) \\ \frac{d}{dx}(g_2 s_2) &= -w_m s_2 + K(s_1 - s_2) \end{aligned} \quad (1)$$

The laws of mass conservation are expressed in the following relations:

$$\frac{dg_1}{dx} = - \frac{dg_2}{dx} = w_m \quad (2)$$

It is generally convenient to use g_1 as the independent variable, and to write $\eta = K/w_m$

$$\begin{aligned} g_1 \frac{ds_1}{dg_1} &= -(1+\eta)(s_1 - s_2) \\ g_2 \frac{ds_2}{dg_1} &= \eta(s_1 - s_2) \end{aligned} \quad (3)$$

The integrals are simply

$$\begin{aligned} s_1 - s_2 &= C \frac{g_2^\eta}{g_1^{1+\eta}} \\ s_1 &= C \frac{g_2^{\eta+1}}{g_0 g_1^{\eta+1}} + L \end{aligned} \quad (4)$$

where C and L are constants of integration and q_0 is the discharge of the river per unit width of the channel. The salinity of the ocean is σ . The discharge at the mouth may be written q_m , hence $q_{2m} = -q_m + q_0$ at the mouth. It is convenient to introduce $p_1 = q_1/q_0$ and $p_2 = q_2/q_0$ or more simply $p_2 = 1 - p_1$. Thus

$$\frac{s_1 - s_2}{\sigma} = - \left(\frac{p_m}{1 - p_m} \right)^\eta \cdot \frac{(1 - p_1)^\eta}{p_1^{1+\eta}}$$

$$\frac{s_1}{\sigma} = \left(\frac{p_m}{1 - p_m} \right)^\eta \cdot \left(\frac{1 - p_1}{p_m} \right)^{1+\eta} \quad (5)$$

In order to illustrate the properties of these solutions, a numerical example is worked out. It is assumed that the discharge of the upper layer at the mouth is ten times the discharge of the fresh river water at the head of the estuary; the results of the computation for various values of η are shown in Figure 4.6.1.

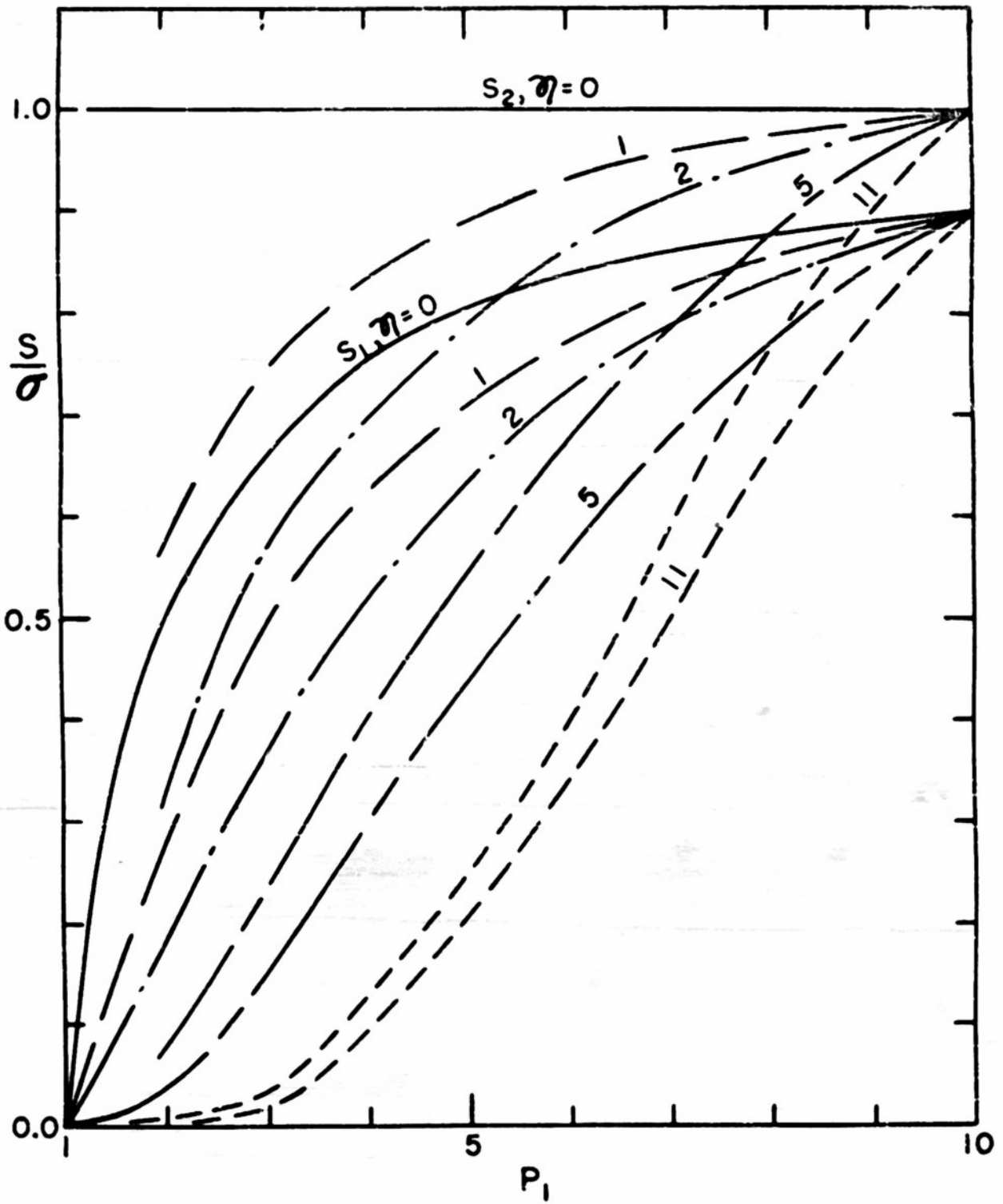

Fig. 4.6.1

4.61 Example: James River

An example of the mixing processes in a Type 2 estuary is obtained from Pritchard's (1951) special study of the James River (see Section 7.23). Figure 4.61.1 shows the mean salinity-depth curves at three stations; the estuary is clearly Type 2, as shown in Figure 7.0.2. Figure 4.61.2 shows the mean ebb and flood velocities for three periods in the James estuary. Figure 4.61.3 shows the total mean velocity-depth curves for each period. If we use the customary right-handed coordinate axis, with x directed downstream, y cross stream, z upward, and denote the instantaneous velocity components as u, v, w ; the salt transfer equation (omitting molecular diffusive transfer) is:

$$\frac{\partial s}{\partial t} = -\frac{\partial}{\partial x}(us) - \frac{\partial}{\partial y}(vs) - \frac{\partial}{\partial z}(ws) \quad (1)$$

Each term may be separated into two terms of the form:

$$A = \bar{A} + A'$$

where \bar{A} is the time mean, and A' the instantaneous deviation from the mean. Pritchard (1951) calls A' a random term, but this term is more nearly a periodic term. Taking the time mean of equation (1) results in the following well known form:

$$\begin{aligned} \frac{\partial \bar{s}}{\partial t} = & -\bar{u} \frac{\partial \bar{s}}{\partial x} - \bar{v} \frac{\partial \bar{s}}{\partial y} - \bar{w} \frac{\partial \bar{s}}{\partial z} \\ & - \frac{\partial}{\partial x}(\overline{u's'}) - \frac{\partial}{\partial y}(\overline{v's'}) - \frac{\partial}{\partial z}(\overline{w's'}) \end{aligned} \quad (2)$$

The right hand member is composed of three advection terms and three eddy diffusion terms. The equation may also be written in the equivalent form:

$$\begin{aligned} \frac{\partial \bar{s}}{\partial t} = & -\bar{u} \frac{\partial \bar{s}}{\partial x} - \bar{v} \frac{\partial \bar{s}}{\partial y} - \bar{w} \frac{\partial \bar{s}}{\partial z} \\ & + \frac{\partial}{\partial x} A_x \frac{\partial \bar{s}}{\partial x} + \frac{\partial}{\partial y} A_y \frac{\partial \bar{s}}{\partial y} + \frac{\partial}{\partial z} A_z \frac{\partial \bar{s}}{\partial z} \end{aligned} \quad (3)$$

(In the case of a Type 1 estuary the only possible terms in the right hand member are the first and fourth, and we are reduced to the case discussed in Sections 4.4 and 4.43).

Pritchard has made a numerical study of these various terms in the James estuary to discover their magnitudes, and takes only mean values with respect to the cross-stream coordinate y . The equation (2) may be written in the form:

$$\begin{aligned} \frac{\partial \bar{s}}{\partial t} = & -\bar{u} \frac{\partial \bar{s}}{\partial x} - \bar{w} \frac{\partial \bar{s}}{\partial z} - \frac{\partial}{\partial x} (\overline{u's'}) - \frac{\partial}{\partial z} (\overline{w's'}) \\ & - \overline{(w's')} \frac{1}{b} \frac{db}{dz} \end{aligned} \quad (4)$$

where b is the breadth of the channel (a function of z).

The terms \bar{u} , $\partial \bar{s} / \partial x$, $\partial \bar{s} / \partial z$ are computed from a series of observations as functions of x and z . The

mean vertical velocity \bar{w} is computed from the field of \bar{u} by mass continuity, and the results shown in Figure 4.61.4. The advective terms of equation (4), $\bar{u} \partial \bar{s} / \partial x$ and $\bar{w} \partial \bar{s} / \partial z$ may now be computed. Vertical integration of the equation (4) permits evaluation of $\partial (\overline{u's'}) / \partial x$ and then $(\overline{w's'})$ may be computed.

Fritchard's field program was undertaken during a period when $|\partial \bar{s} / \partial t| < 10^{-7}$ ‰ sec⁻¹. The term $\bar{u} \partial \bar{s} / \partial x$ varied from about 5×10^{-5} ‰ sec⁻¹ in the upper layer, to -5×10^{-5} ‰ sec⁻¹ in the bottom layer. The term $\partial (\overline{u's'}) / \partial x$ was negligible, less than 10^{-7} ‰ sec⁻¹. The vertical advective term, $\bar{w} \partial \bar{s} / \partial z$ was of the order of 10^{-5} ‰ sec⁻¹.

The vertical eddy flux term $\partial (\overline{w's'}) / \partial x$ was of the order of -4×10^{-5} ‰ sec⁻¹ in the lower layer. The vertical distribution of the vertical eddy flux of salt $(\overline{w's'})$ is shown in Figure 4.61.5. Since some of the stations were taken at different phases of the moon, the values of eddy flux as functions of tidal velocity may be computed, Figure 4.61.6.

A rough comparison with Section 4.6 may be made. At the halocline the value of $\overline{w_m}$ is about 4×10^{-5} ft/sec. The value of the eddy flux $(\overline{w's'})$ at the halocline, (or $-K(s_1 - s_2)$ in equation (4.6.1), is approximately 40×10^{-5} ‰ ft/sec. From Figure 4.61.1 we can see that the value of $(s_1 - s_2)$ is nearly -2 ‰. Thus, γ , as defined in Sec-

tion 4.6, has a value of about 5. The salinity distribution for $\eta = 5$, in Figure 4.6.1 resembles that of the James estuary.

It is interesting to try to compute the value of w_m at the halocline from Keulegan's formula for mixing. From Figure 4.61.2 we see that $U_i = 0.3 \text{ ft. sec}^{-1}$ and that this is well above $U_c \approx 0.05 \text{ ft. sec}^{-1}$. Hence, by equation (4.8.2) the value of w_m is computed to be $w_m = 8 \times 10^{-5} \text{ ft. sec}^{-1}$, whereas the observed value, according to Figure 4.61.4 is more nearly $w_m = 4 \times 10^{-5} \text{ ft. sec}^{-1}$.

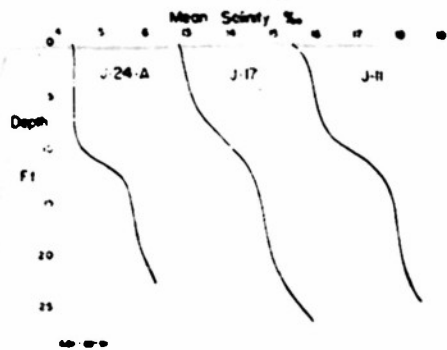

Figure 4.61.1 Mean salinity-depth curves at three stations

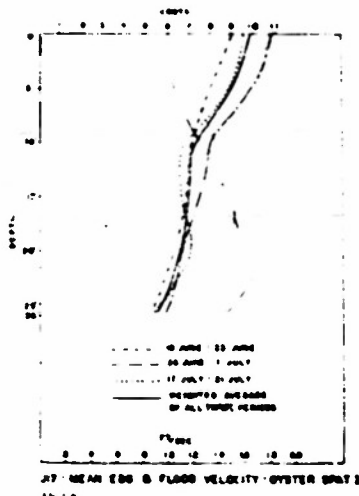

Figure 4.61.2 Mean ebb velocities (heavy lines); mean flood (light) for three periods

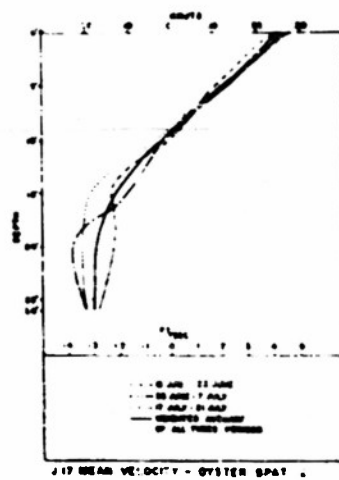

Figure 4.61.3 Mean velocities for three periods in James River.

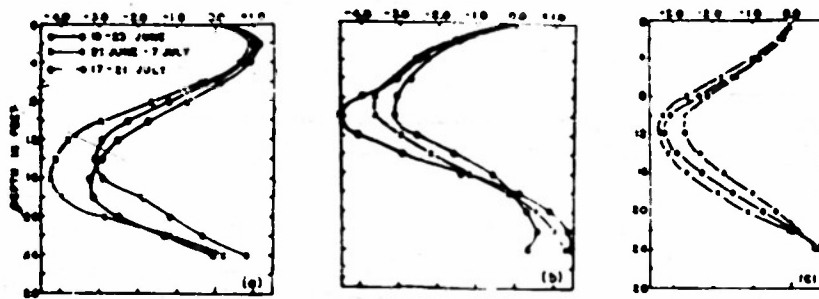

Figure 4.61.4 Abscissa is vertical velocity w (with minus sign) $\times 10^5$ ft sec $^{-1}$.

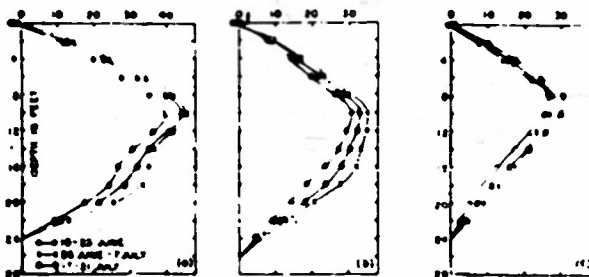

Figure 4.61.5 Abscissa is vertical eddy flux $\overline{wv} \times 10^5$ ft sec $^{-1}$.

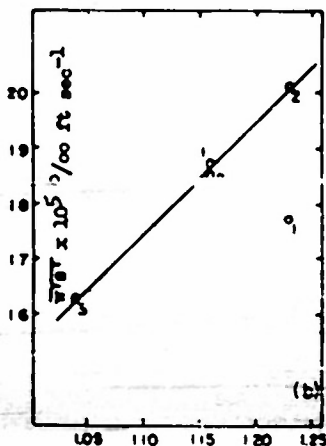

Figure 4.61.6 Mean value of vertical eddy flux as function of tidal velocity.

4.62 A relation between estuaries with horizontal mixing and with vertical mixing

The salinity distributions shown in Figures 4.6.1 and 4.4.1 look very similar, but come about as the results of two entirely different models. The writer is of the opinion that there is a fundamental equivalence between the two models. Dr. Henry Kierstead pointed out that this equivalence may be interpreted in the following way.

Consider a two-layer system in which the velocity of the two layers are u_1 and u_2 . Suppose that the mean velocity is \bar{u} . Particles which move randomly in the vertical will have a downstream drift of \bar{u} . If the eddy vertical velocity of the particles is w and they travel on the average the entire depth d , then a vertical eddy diffusivity describing the flux of particles is of the form

$$A_z \cong wd$$

In moving up and down the particles spend a time τ in each layer on the average, so that associated with vertical displacement is a horizontal displacement $(u_1 - \bar{u})\tau$. A horizontal diffusivity may be expressed as:

$$A_x \cong (u_1 - \bar{u})^2 \tau$$

and since

$$w\tau \cong d$$

$$A_x \sim \frac{(u_1 - \bar{u})^2 d^2}{A_z}$$

The remarkable fact is that A_x and A_z are inversely proportional. Thus large vertical turbulence confines a pollutant to a particular horizontal position which moves only with drift velocity \bar{u} .

Another way of showing this odd equivalence is to integrate vertically the results of Section 4.6, and reformulate them into a single equation of the type of Section 4.4. For simplicity's sake we consider only the case, which is often realized in Type 2 estuaries, in which the two layers are of equal depth: $D_1 = D_2 = d/2$

The vertical average of salinity \bar{s} is thus

$$\bar{s} = (s_1 + s_2) / 2$$

The average velocity is

$$\bar{u} = (g_1 + g_2) / d$$

From equation (4.6.4)

$$\bar{s} = 2C g_2^\eta / g_1^{\eta+1}$$

and

$$\frac{d\bar{s}}{dg_1} = 2C \left[\frac{\eta g_1 - (1+\eta)g_2}{g_1 g_2} \right] \frac{g_2^\eta}{g_1^{\eta+1}}$$

If we write an equation analogous to (4.4.8)

$$\bar{u} \bar{s} = A_z \frac{d\bar{s}}{dg_1} w_m = A_z \frac{d\bar{s}}{dx}$$

the quantity

$$A_z = \frac{g_0}{d} \frac{g_2 - g_1}{w_m (\eta g_1 - (1+\eta)g_2)}$$

For large values of γ and g_1 , the equation is simply

$$A_2 = g_0 g_1 / \kappa d$$

which is similar to the expression obtained by the elementary particle analysis above.

An important corollary of this inverse relation between A_x and A_2 is that the greater the tidal currents, the fresher the estuary. It should be very interesting to discover whether in fact an estuary of Type 2 is freshened by spring tides, but an estuary of Type 1 is made more saline.

4.8 Interfacial mixing

The phenomenon of mixing across a sharp interface is peculiar in that it is not a "two way" mixing of the type described by the usual theoretical treatments of turbulence, but is a "one way" process. So far as this writer knows, the only study of this type of mixing is that by Keulegan (1949), who points out that two forms of interfacial mixing may occur: "In one form, the interface may be identified as the dividing surface of two layers of liquid with different densities, the surface being one of sharp discontinuity of densities but not necessarily of velocities. Ordinarily the interface of this type is the locale of internal waves if the difference in velocities at points on opposite sides of the interface and at some distance from it is large. If mixing is present, it is in the form of eddies that are periodically ejected from the crests of the waves into the current that has the greater velocity. In the other form, the interface is a layer of transition between two currents. Both the densities and the velocities change uniformly in the layer that has measurable thickness. If any mixing is present, it is associated with the momentum exchange of turbulence, and the regular pattern of internal waves is absent."

Keulegan's study (1949) of mixing of the first form was made in three flumes in which the upper layer of fluid was recirculated many times over the lower layer of heavier fluid.

The mechanism of mixing was the breaking of the crests of interfacial waves into the moving upper layer.



A criterion of mixing has been obtained in the form

$$\theta = \left(\nu_2 g \frac{(\rho_2 - \rho_1)}{\rho_1} \right)^{1/3} / U_c \quad (1)$$

where subscripts refer to the two fluids in the usual way, and ν_2 is the kinematic viscosity of the lower fluid.

The value of θ appears to be about 0.178 in the turbulent region ($U_c D_1 / \nu_1 > 450$).

Keulegan defines the amount of mixing for velocities above the critical in the same fashion as we have defined w_m (Section 3.1, page 6).

The law for mixing is of the form

$$w_m = 3.5 \times 10^{-4} (U - 1.15 U_c) \quad (2)$$

"The bearing of the results of the present investigation on the interfacial mixing occurring in large bodies of water in stratified flow must be discussed.

"In the laboratory experiments, where relatively

short flumes are used and one of the liquids, the lower or the upper, is at rest, and the other is in motion, the state of the interface is one of discontinuity of density. In the case when the lower heavy liquid moves, it will be supposed that the flow has continued for a long time and that the characteristic wave front is absent. Under these conditions, the interfacial stability, the critical velocity of mixing, and the mixing for velocities above the critical, may be studied. All these, however, refer to a reach that is to be looked upon as a type of initial length.

"In the phenomenon transpiring in natural environments and thus involving large bodies of water in stratified flow, it may be assumed that conditions arise so that initial reaches are established. It is expected that the changes taking place in the initial length will be similar to those observed in a laboratory. What is not known definitely in this respect is the direct applicability of the results to be obtained in a laboratory investigation to the prototype magnitudes. Certainly, however, a qualitative similarity, at least, must exist.

"If that is granted, the application of the laboratory results must be restricted to a very short reach, which will be viewed as the initial reach. Beyond this in the remaining reach, which will be of considerable length, the conditions for mixing and the manner of mixing will be of a different type, obeying different laws. For the mix-

ing in the initial reach will establish in the following adjoining reach a transition layer between the liquids, and in this transition layer the density will vary continuously. As an illustration of how this can be brought about, we may visualize the following situation. A current of fresh water of depth H is flowing with a uniform velocity over a pool of heavier liquid. In places in the initial length, portions of liquid coming from the lower pool will spread themselves in the upper current only gradually. Let it be supposed that the spreading is proportional to time, this being measured from the instant of departure from the lower liquid. The density gradient established for this case can be obtained readily. Taking the instant when the spreading is completed and the area covered is a square of sides of length H , the concentration along a vertical may be represented by

$$C = A + B/y$$

for finite distances away from the interface.

"Now, the actual law of spreading for a given actual case may not be as simple as in the above illustration. As long as it is assumed that spreading of liquids ejected from below into the upper current and in the initial length is gradual, a qualitatively similar law for the concentrations as the one mentioned above will be expected. But these distributions imply the existence of transition layers. Whereas the mixing in the case of sharp interfaces is brought about

by the ejection of eddies at the crests of the internal waves, the mixing through the transition layers must be associated with the momentum exchange of turbulent motion. This is a matter to be approached using the basic ideas of the Prandtl and Richardson criterion for mixing and is, therefore, a subject outside the scope of the present investigation."

4.9 Measurements of microturbulence in estuaries

In the theories presented in earlier sections of this chapter, the turbulent elements responsible for transfer of properties have been considered to be of a tidal period. If such processes are said to be associated with "macroturbulence" then we may call turbulent fluctuations of period much less than a tidal period "microturbulence". There have been few direct measurements of microturbulence in estuaries.

Thorade (Rapports et Proces-verbaux, Cons. Per. Intern. l'Explor d.l. Mer 76, 1931) discusses work of Rauschelbach who measured velocity continuously in the Elbe at about mid-depth (total depth 8 m.). Turbulent fluctuation of 300 second period, with amplitude of about 10 cm sec^{-1} , occurred superposed on a mean velocity of about 20 cm sec^{-1} . Bowden and Proudman (Proc. Roy. Soc. A. 199, pp. 311-327) have made an extensive set of observations in the Mersey, and found two periods of fluctuation: (i) a short period fluctuation of a period of about 5 seconds; (ii) a longer period fluctuation of about 90 seconds. In both cases the ratio of amplitude of the turbulent fluctuation to the mean velocity is of the order of 0.1 (independent of mean current). A positive picture of the physical nature of the eddies (or waves?) responsible for these fluctuations has not evolved, nor do we know their role in the transport processes. Much observational work remains to be done in this direction.