

UNCLASSIFIED

AD NUMBER
AD009425
NEW LIMITATION CHANGE
TO Approved for public release, distribution unlimited
FROM Distribution authorized to U.S. Gov't. agencies and their contractors; Administrative/Operational Use; 01 NOV 1952. Other requests shall be referred to Office of Naval Research, Washington, DC.
AUTHORITY
onr ltr, 9 nov 1977

THIS PAGE IS UNCLASSIFIED

Reproduced by

Armed Services Technical Information Agency

DOCUMENT SERVICE CENTER

KNOTT BUILDING, DAYTON, 2, OHIO

AD -

9	4	2	5
---	---	---	---

UNCLASSIFIED

DISCLAIMER NOTICE

THIS DOCUMENT IS BEST QUALITY PRACTICABLE. THE COPY FURNISHED TO DTIC CONTAINED A SIGNIFICANT NUMBER OF PAGES WHICH DO NOT REPRODUCE LEGIBLY.

OFFICE OF NAVAL RESEARCH
CONTRACT N5 ORI-76 PROJECT ORDER X

NR-384-903

TECHNICAL MEMORANDUM
NO. 28

THE APPLICATION OF
CORRELATION TECHNIQUES
TO ACOUSTIC RECEIVING SYSTEMS

BY

JAMES J. FARAN, JR.

ROBERT HILLS, JR.

NOVEMBER 1, 1952

ACOUSTICS RESEARCH LABORATORY
DIVISION OF APPLIED SCIENCE
HARVARD UNIVERSITY - CAMBRIDGE, MASSACHUSETTS

HU/ARL TM 28

9425

AD NO.

ASTIA

FILE COPY

Office of Naval Research
Contract N5ori-76, Project Order X

Technical Memorandum No. 28

The Application of Correlation Techniques
to Acoustic Receiving Systems

by

James J. Faran, Jr. and Robert Hills, Jr.

November 1, 1952

Summary

The application of correlation techniques to acoustic receiving systems is considered theoretically and experimentally. The study is limited, for the most part, to random signals in a background noise which arises in the signal-bearing medium (not in the receiver amplifiers). For example, cross-correlating the signals received by a two-element array is compared with simply adding these signals and detecting with a square-law detector. In some cases, the correlator can effect an improvement in the signal-to-noise ratio of as much as 3 db, while, in other cases, conventional methods result in higher signal-to-noise ratios. The systems using correlators, however, usually exhibit a practical advantage which may offset any signal-to-noise ratio disadvantage; the average output of the correlator usually contains no large term proportional to the strength of the background noise. This allows the use of much higher gain recording or indicating instruments after the correlator. Several methods of performing multiple correlation for use with arrays of more than two elements are considered; nothing significantly superior to a simple adding of all the signals and detecting has been found.

Acoustics Research Laboratory

Division of Applied Science

Harvard University, Cambridge, Massachusetts

AD 9411

PREFACE

This is the second technical memorandum on the subject of our investigation of the possible applications of correlation techniques to acoustic receiving systems. The first, Technical Memorandum No. 27, is concerned entirely with theoretical analysis of correlators, comparison of correlators with detectors, and the design of practical electronic correlators. In this report the application of correlation techniques to particular acoustic receiving systems is considered, and the results of theoretical and experimental studies are reported.

This study of correlation techniques was suggested by Professor F. V. Hunt, and the authors are greatly indebted to him for his helpful and stimulating guidance of the project. We also greatly appreciate the assistance of Professor Harvey Brooks, who helped us to get started mathematically on this work.

TABLE OF CONTENTS

PREFACE	1
Chapter I INTRODUCTION	1
Chapter II EXPERIMENTAL APPARATUS	4
Speaker Array	4
Noise Generators	5
Signal Insertion System	6
Receiver Mount	7
Receiver Amplifiers	7
Ninety-Degree Phase-Shifter	8
Nonlinear Signal Processing Devices	9
Recorder	9
Output Noise Meter	9
Chapter III CORRELATION IN NOISE FIELDS	11
Cross-correlation in a Three-Dimensional Isotropic Noise Field	12
Evaluation for Rectangular Spectrum	13
Evaluation for Tuned-Circuit Spectrum	14
Cross-correlation in a Two-Dimensional Isotropic Noise Field	16
Chapter IV APPLICATION OF CORRELATION TECHNIQUES TO TWO-ELEMENT ARRAYS	18
Two-Element Array with Correlator	20
Two-Element Array with Square-Law Detector	22
Two-Element Array with 90-degree Phase Shift	26
Two-Element Array with Directional Receivers	28
Chapter V APPLICATION OF CORRELATION TECHNIQUES TO ARRAYS OF MORE THAN TWO ELEMENTS	33
Many Correlators	35
m-Fold Product	37
Multiple-Polarity-Coincidence Correlation	41
Chapter VI POST-DETECTION CORRELATION SYSTEMS	51
BIBLIOGRAPHY	54

TABLE OF CONTENTS

PREFACE	1
Chapter I INTRODUCTION	1
Chapter II EXPERIMENTAL APPARATUS	4
Speaker Array	4
Noise Generators	5
Signal Insertion System	6
Receiver Mount	7
Receiver Amplifiers	7
Ninety-Degree Phase-Shifter	8
Nonlinear Signal Processing Devices	9
Recorder	9
Output Noise Meter	9
Chapter III CORRELATION IN NOISE FIELDS	11
Cross-correlation in a Three-Dimensional Isotropic Noise Field	12
Evaluation for Rectangular Spectrum	13
Evaluation for Tuned-Circuit Spectrum	14
Cross-correlation in a Two-Dimensional Isotropic Noise Field	16
Chapter IV APPLICATION OF CORRELATION TECHNIQUES TO TWO-ELEMENT ARRAYS	18
Two-Element Array with Correlator	20
Two-Element Array with Square-Law Detector	22
Two-Element Array with 90-degree Phase Shift	26
Two-Element Array with Directional Receivers	28
Chapter V APPLICATION OF CORRELATION TECHNIQUES TO ARRAYS OF MORE THAN TWO ELEMENTS	33
Many Correlators	35
m-Fold Product	37
Multiple-Polarity-Coincidence Correlation	41
Chapter VI POST-DETECTION CORRELATION SYSTEMS	51
BIBLIOGRAPHY	54

INTRODUCTION

The application of correlation techniques to acoustic receiving systems has been under consideration from the point of view of the following question: Can techniques suggested by correlation theory be used to improve the ability of a receiving system to detect the presence of a weak signal in noise or to improve its ability to localize the direction of a source? We have considered the case where the background noise arises in the signal-bearing medium (rather than in receiver amplifiers), and where the signal is a random function having the same spectrum as the background noise. We have investigated several different systems of reception and processing which make use of correlation techniques and have compared them with similar but more conventional systems. The answer to the question above appears to be, briefly, that some correlator systems which we have investigated can improve the signal-to-noise ratio slightly, but not more than 3 db, and in some cases actually lower the signal-to-noise ratio; correlators, on the other hand, have other operational advantages which may even offset signal-to-noise ratio disadvantages. Correlation systems can do nothing, so far as these studies have disclosed, to improve the ability of a system to localize the direction of a signal source, but again may have some operational advantages in this use.

The concept of trading time-space for frequency-space which has arisen from comparing correlation systems with filtering systems has suggested the possibility of in some way trading signal-processing time for the physical size of a receiving array. A statement of some of the early thinking at this Laboratory on this subject has been published;¹ however, in the course of the investigations reported in this memorandum, we have not yet come to grips with this aspect of the problem, although some of our work bears on this question.

The application of correlation techniques to acoustic receiving systems has already received some consideration in the literature. The general subject of the use of correlation techniques in the detection of weak signals in noise, without reference to any particular system of receiving transducers, has been studied thoroughly.²⁻⁶ Some of the papers here cited discuss autocorrelation methods for the detection of periodic signals in noise; this method is of no avail if the signal is not periodic, and we have not considered it here. Effective receiving beam patterns for some simple correlation systems have been given by Nodtvedt.⁷ He did not, however, consider the important question of output signal-to-noise ratio. On the other hand, Icole and Oudin⁸ have compared output signal-to-noise ratios of various correlation and conventional systems without consideration of the beam patterns (on which the resolving power of the system depends).

Because we do not feel that at the moment any broad statement can be made about the usefulness of correlation techniques, this report has taken the form of a set of detailed studies of various correlation systems, and comparisons of these with their more conventional counterparts, if such exist. The correlation systems studied are those which appeared to have the most promise, or those which would most readily come to mind.

This memorandum leans heavily on its predecessor, TM 27,⁶ for mathematical derivations of output signal-to-noise ratios for various correlators and detectors. In the earlier memorandum some other questions relating to signal processing and detection are discussed briefly; these include the important subject of optimum filters.

References

1. Hunt, F. V., "Perturbation and Correlation Methods for Enhancing the Space Resolution of Directional Receivers," Proc. I. R. E. 39, 840 (July, 1951).

2. Lee, Y. W., T. P. Cheatham, Jr., and J. B. Wiesner, "Application of Correlation Analysis to the Detection of Periodic Signals in Noise," Proc. I. R. E. 38, 1165-1171 (October, 1950)
3. Fano, R. M., Signal-to-Noise Ratio in Correlation Detectors, Technical Report No. 186, Research Laboratory of Electronics, Massachusetts Institute of Technology, Cambridge, Massachusetts. (February 19, 1951).
4. Eckart, Carl, The Measurement and Detection of Steady A. C. and D. C. Signals in Noise, University of California Marine Physical Laboratory of the Scripps Institution of Oceanography (October 4, 1951).
5. Rudnick, Philip, The Detection of Weak Signals by Correlation Methods, University of California Marine Physical Laboratory of the Scripps Institution of Oceanography (May 10, 1952).
6. Faran, J. J., Jr., and R. Hills, Jr., Correlators for Signal Reception, Technical Memorandum No. 27, Acoustics Research Laboratory, Harvard University, Cambridge, Massachusetts. (September 15, 1952). This memorandum will be referred to below simply as TM 27.
7. Nodtvedt, H., "The Correlation Function in the Analysis of Directive Wave Propagation," Phil. Mag. 42, 1022-1031 (September 1951).
8. Icole, J., and J. Oudin, "Analyse Temporelle et Filtrage," Ann. Telecommun. 7, 99-108 (Feb. 1952).

EXPERIMENTAL APPARATUS

It was early recognized that Harvard's large anechoic chamber¹ offered an ideal environment for an experimental study of acoustic receiving systems. To this end there was constructed a large semicircular array of small loudspeakers, each of which could be driven by a separate noise generator. With this system it was possible to produce, at the center of the array, a good approximation to a two-dimensional isotropic noise field. Various receiving systems were then assembled at the center of the large array, and compared as to their ability to detect and localize a "signal" superposed on the background noise applied to one of the speakers. Receiving amplifiers, detectors, correlators, voltmeters, and a recorder completed the apparatus necessary for these tests. Most of this apparatus will be described below in more detail.

Speaker Array

Forty-one 5-in. loudspeakers (Cletron PM 5BB) were mounted on a semicircular arc 29ft., 4in. in diameter of aluminum "tee" section (1-1/2 in. X 1-1/2 in. X 3/16 in.). The whole assembly was hung from steel cables in a vertical plane in the anechoic chamber. The photograph of Fig. 2.1 is a general view of the array, while its dimensions are given in the drawing of Fig. 2.2. The speakers are located at 5-degree intervals around the arc. In most tests (where the receiving array was equally sensitive at the rear as at the front) only 36 of the speakers were used to create an isotropic (two-dimensional) noise field. As might be expected, the frequency responses of the individual speakers varied considerably, none having the particularly flat response that was desired. In an attempt to smooth the responses of these speakers, and to make them more uniform, all of the speakers were treated by stuffing the space between the cone and the metal frame with PF Fiberglass and painting the rim compliance with a thick coat of Viscoloid (which had been dissolved in acetone). This treatment seriously decreased the low-frequency response of the speakers because of the increased stiffness, but effected

substantial improvement in the smoothness of response in the range of interest, 1.5 to 4.5 kc/s. It was also found necessary to wrap the entire aluminum "tee" frame with a 2-in. layer of PF Fiberglas in order to reduce reflections from it which by destructive interference caused further irregularities in the speakers' responses. The photograph of Fig. 2.1 was taken prior to this treatment. The response was by no means completely smooth after these treatments; the solid curve of Fig. 2.3 shows the intensity spectrum of the system measured (with a constant voltage applied to the voice coil of a single speaker) at the output terminals of a receiver amplifier (see below) with its tuned-circuit band-pass filter set at $Q = 2$. The dashed curve in this figure is the response spectrum of a tuned circuit having a $Q = 2$, which is what the system response curve would be if all of the system except the filter were flat. It is obvious that the departure of the actual spectrum from the tuned-circuit spectrum is proportionately much less for narrower filter pass-bands.

Noise Generators

Each of the speakers in the array was driven by a separate noise generator. Figure 2.4 is a schematic diagram of one of these. As originally designed, the plate resistor of the 6A2 voltage regulator tube was chosen so that the current drawn would be in the normal operating range of the tube, say 10 ma. It was found, however, that the noise voltage output increased as the size of this plate resistor was increased. The value of 2.2 megohms was chosen as the largest possible for which the output spectrum did not fall off appreciably at 10 kc/s. The first 6AG5 is used as a voltage amplifier, and the second as a power amplifier. The primary of the output transformer is tuned roughly to 4 kc/s, and, when the secondary is loaded with a dummy 4-ohm load, the output intensity spectrum has the form shown in Fig. 2.5. Each generator delivers about 0.3 volt of noise at the terminals of the speaker voice coil. Each noise generator was constructed in a small box with an octal socket at the base, so that they could all be

mounted in a rectangular array on one large relay-rack panel. A defective generator can be easily replaced by simply unplugging it and plugging in a new one. The generators are connected to the speakers in the array via a panel which holds test points which allow easy measurement of the output voltage of each generator, and switches by means of which each generator can be disconnected from its speaker. Each noise generator draws 8 ma at 300 volts from one large electronically regulated plate power supply. It was found necessary to operate the heaters of the noise generators on direct current to prevent the appearance in the outputs of transients occurring at a rate of 60 cps. Figure 2.6 is a photograph of the noise generators, the test and switch panel, and the power supplies mounted in a relay rack ready for use.

Signal Insertion System

In order to allow measurement of receiving system signal-to-noise ratios, provision was made for the superposition of a signal voltage on the background noise voltage applied to one of the small speakers. To this end, the lowest impedance (4 ohms) output of a MacIntosh model P50B audiofrequency power amplifier was connected in series with the output of one of the noise generators and its speaker. Because of feedback incorporated in the MacIntosh amplifier, the effective output impedance was considerably less than 4 ohms (with the amplifier on), and this arrangement caused negligible decrease in the background noise signal reaching the speaker. During the adjustment of the background noise voltage the MacIntosh was kept turned on, but with the gain set at zero, while during adjustment of the signal amplitude, the noise generator was kept turned on, so that it would have its operating output impedance, but the noise was turned off by means of its gain control. Almost all experiments were conducted with random signals. The signal noise voltage was obtained from the 42nd noise generator on the panel, which was equipped with a dummy load resistance, and connected to the input of the MacIntosh amplifier.

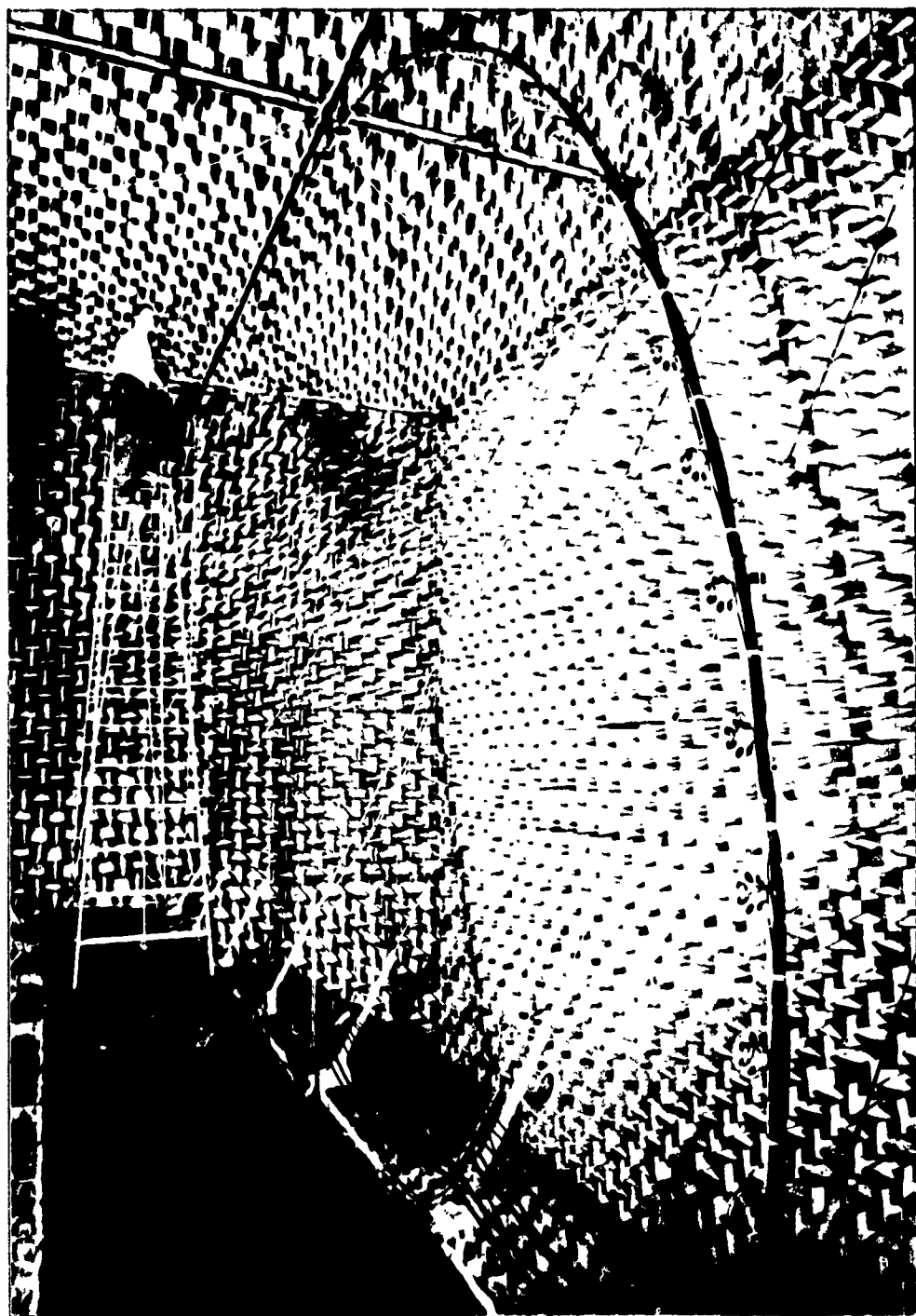

Fig. 2.1. Photograph of background noise array hung in Harvard's large anechoic chamber.

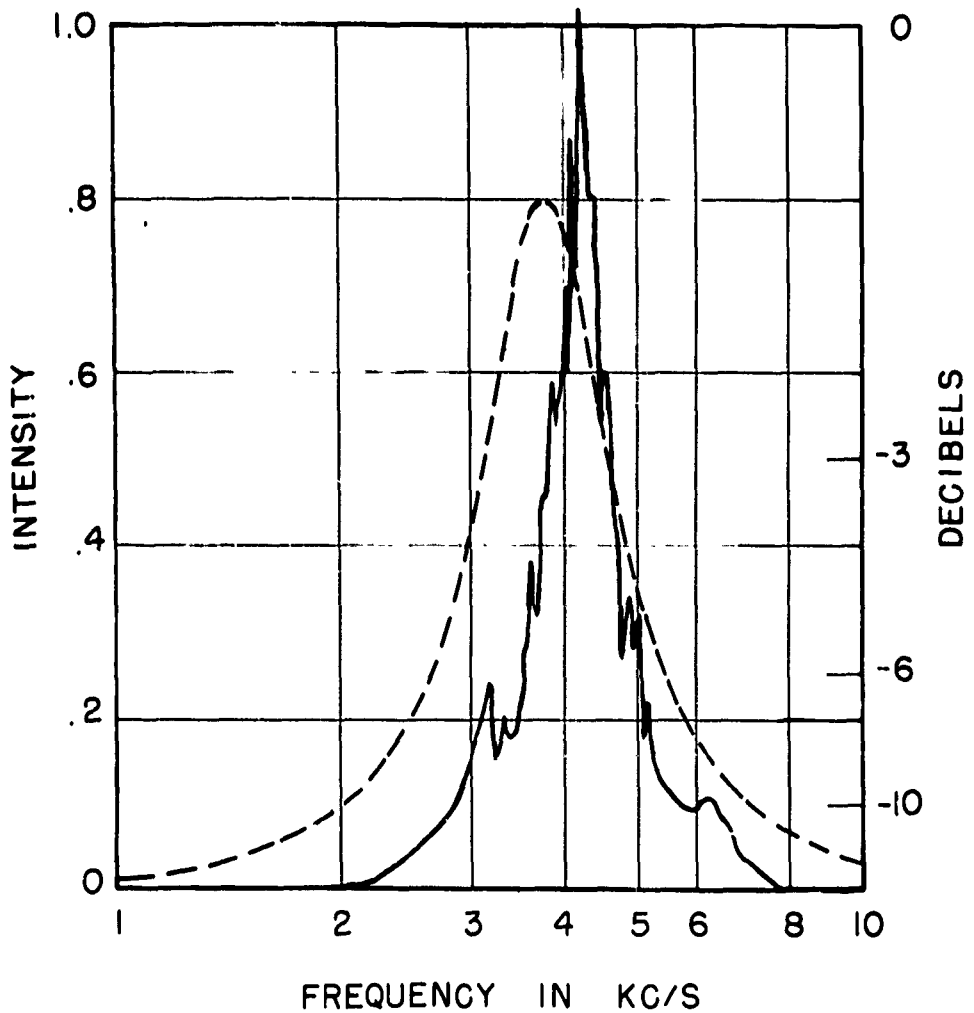

Fig. 2.3. Intensity spectrum of transmission system including background noise speaker, receiving microphone (Western Electric 633-A), and receiver amplifier with single-tuned-circuit filter set for $Q = 2$. The dashed curve is the intensity response spectrum for the filter alone; this is what the system response would be if the speakers and microphones were perfect.

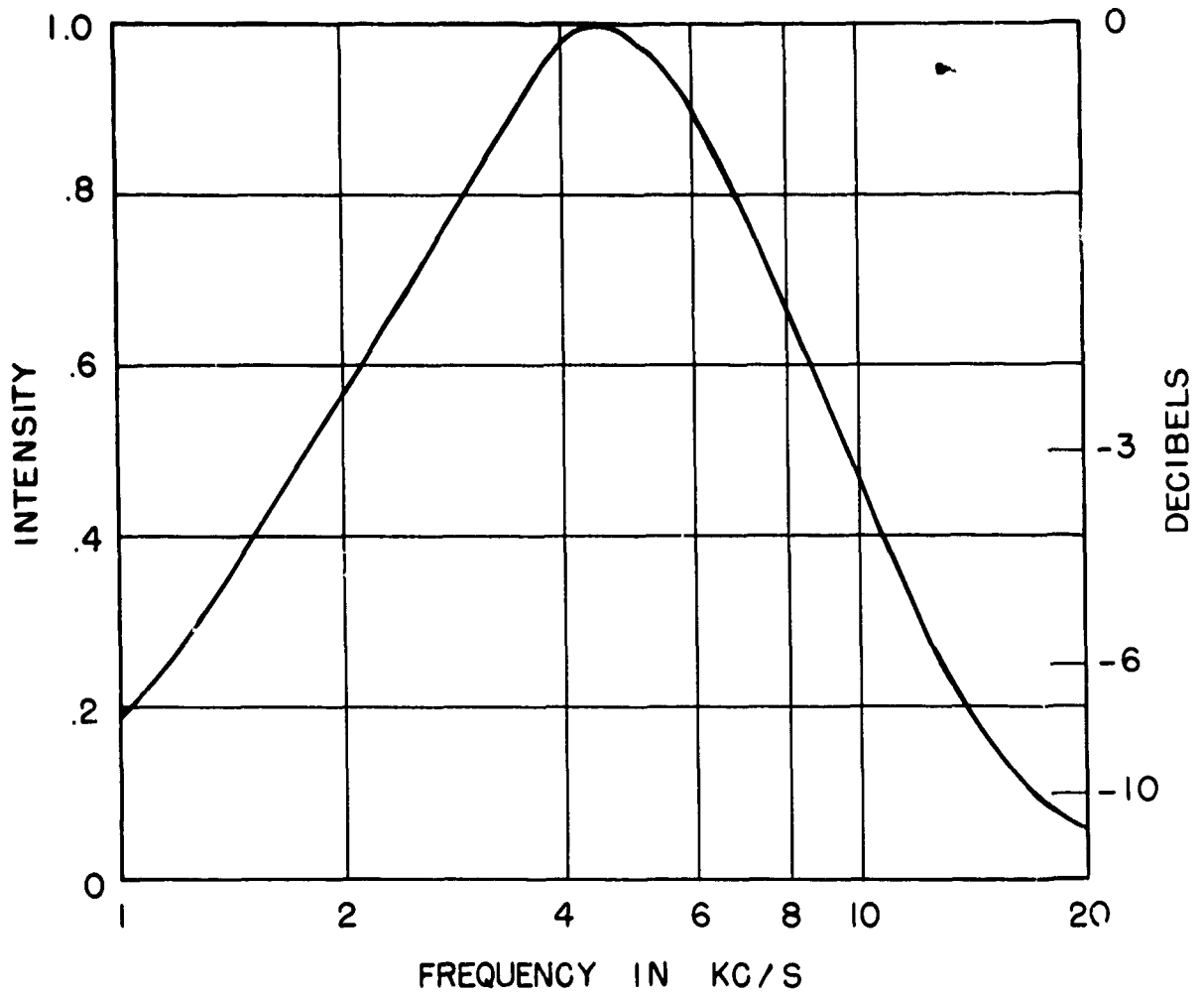

Fig. 2.5. Output intensity spectrum of miniature noise generator.

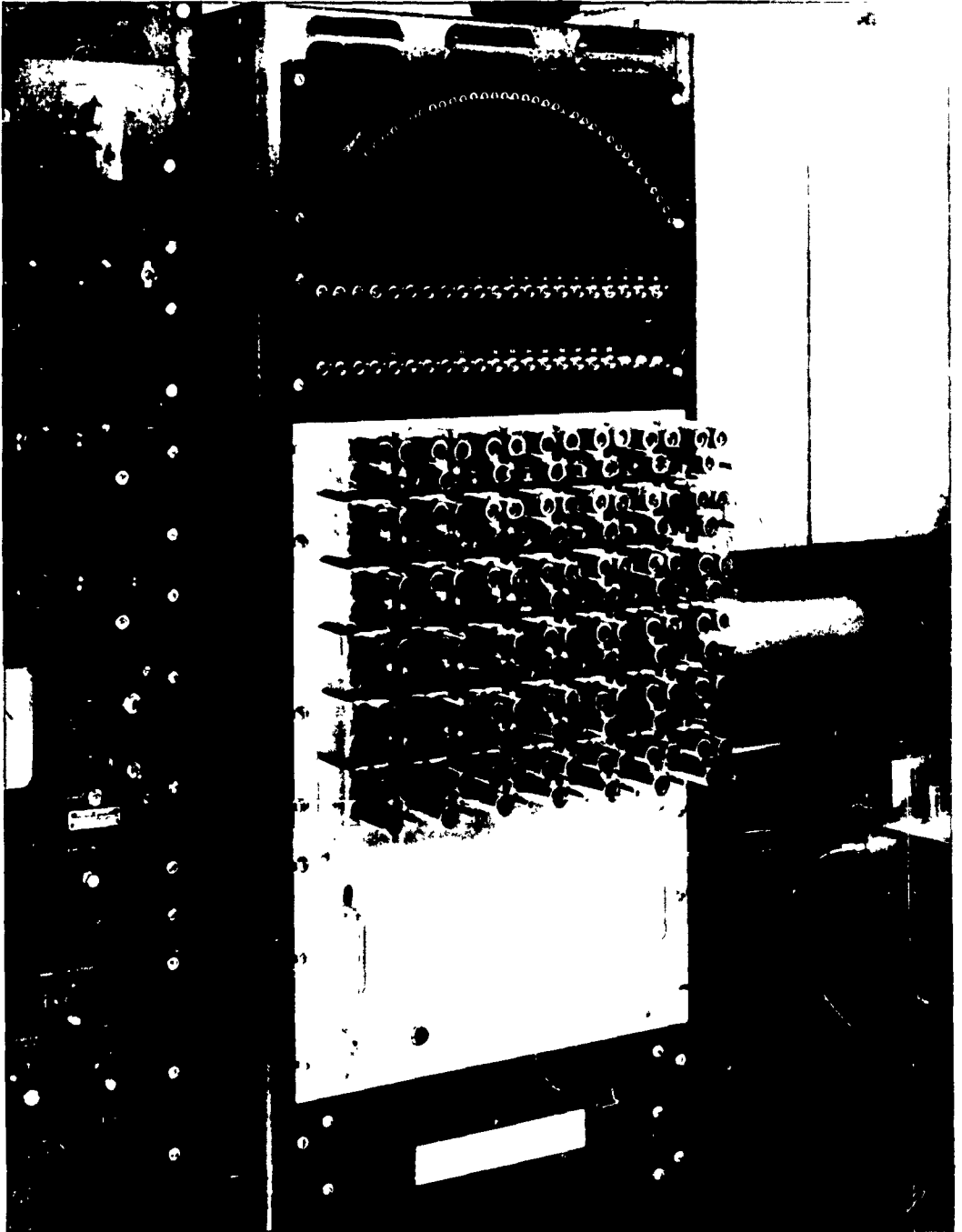

Fig. 2.6. Photograph of noise generator rack, showing, from top to bottom, voltage test panel, switch panel, noise generators and their power supplies.

Receiver Mount

A steel frame, shown in Fig. 2.7, was constructed to support a hollow shaft at the center of the large array. Another shaft, inside the hollow one, carries a cross bar on which microphones or other receiving transducers are mounted. The inner shaft can be extended outward and allows the receivers to be accurately positioned at the center of the large array. A servo-controlled motor turns the telescoping shaft so that its position always corresponds to the horizontal position of the pen on the recorder (see below). In most cases, linear arrays of Western Electric 633-A microphones were used. Although these receiving arrays were never longer than 2 ft over-all, it was found necessary to curve the bar supporting the microphones. This was done to insure that the signal, coming from a speaker only 15 ft away, would arrive in phase at each element of the array. The curvature necessary to achieve this (15-ft radius) was so slight that it was assumed that there was no significant change in the response of the array to the background noise. A "pillory" of 1/4 in aluminum was constructed to fit over the bodies of the microphones to insure their proper positioning. The holes in this device were spaced exactly one wavelength at 3800 cps, center to center. A linear array of microphones with the "pillory" in place is visible in Fig. 2.7.

Receiver Amplifiers

The signals from the microphones were amplified and filtered before being detected or correlated. A schematic diagram of one of the twin-channel amplifiers constructed for this purpose is shown in Fig. 2.8. The input impedance of this amplifier matches the impedance of the 633-A microphones. The input circuits are arranged so that the amplifier may be switched to sum-and-difference operation if so desired. A single-tuned-circuit filter is included in the plate circuit of the third stage. Its center frequency is 3800 cps and its Q is adjustable to 2, 4, and 8. The output stage is sufficiently powerful to supply up to 10 volts

into a 500-ohm load. The gain of these amplifiers has proved quite adequate for the experiments to be described. In all, three such amplifiers have been built, providing six channels. Care was taken to match all six of the filters in all three positions for both center frequency and Q. Phase comparison was found to be a very sensitive test for this alignment. Not including the tuned circuits, the frequency response of the amplifiers is very wide, extending at least from 500 to 30,000 cps. With the filters, the average measured bandwidth between half-power points is 430 cycles, for $Q = 8$; 950 cycles, for $Q = 4$; and 1900 cycles, for $Q = 2$.

Ninety-Degree Phase-Shifter

In some experiments it was necessary to provide a phase difference of 90 degrees between two signal channels. This proved much more difficult than one might expect in a typical single-frequency case because of the wide bandwidth of the received signals. A wide-band 90-degree phase-shifter has been built successfully, however, according to a method described by Brown.² A schematic diagram of this circuit is shown in Fig. 2.9. Each channel consists of four RC phase-shifters which act independently on the channel phase shift, since they are isolated by cathode-followers. The difference in phase shift between any corresponding pair in the two channels has a maximum of nearly 90 degrees at some particular frequency, and falls slowly to zero at either side of that frequency. The four frequencies of maximum phase difference are chosen so that the sum of the four phase-difference curves is constant at 90 degrees for a wide range. For this circuit, after adjustment, the measured phase-shift difference is $90^\circ \pm 3^\circ$ from 55 to 18,000 cps. Obviously, if the range is to be extended, or the tolerance decreased, more sections must be used and the design recomputed. A method has come to our attention for the design of passive wide-band 90-degree phase-shift networks.³ The reader is referred to this as being probably a more elegant solution of this problem.

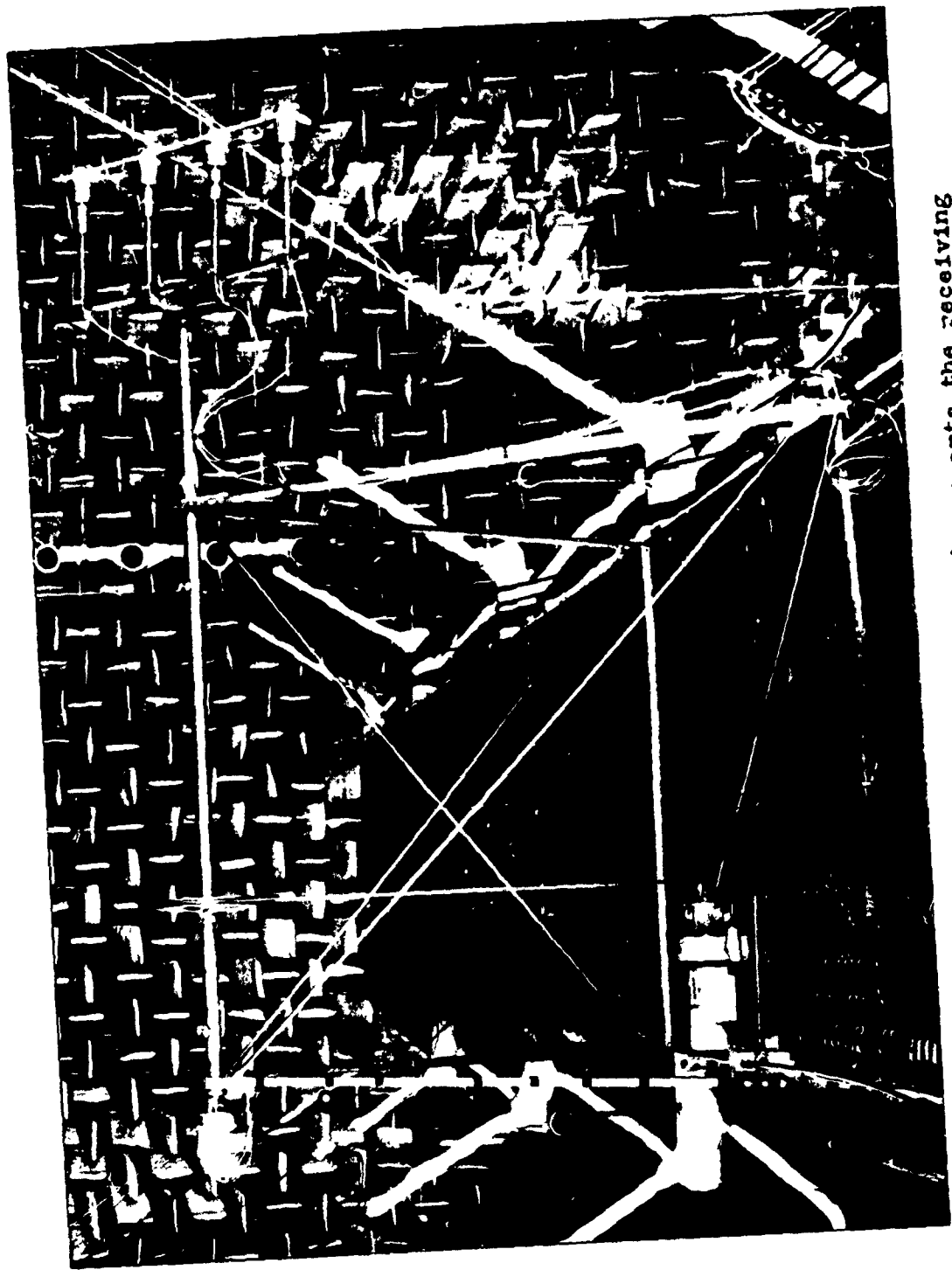

Fig. 2.7. Photograph of frame which supports the receiving array at the center of the background array. In place is a four-element array of 633-A microphones with "pillory" which insures proper spacing.

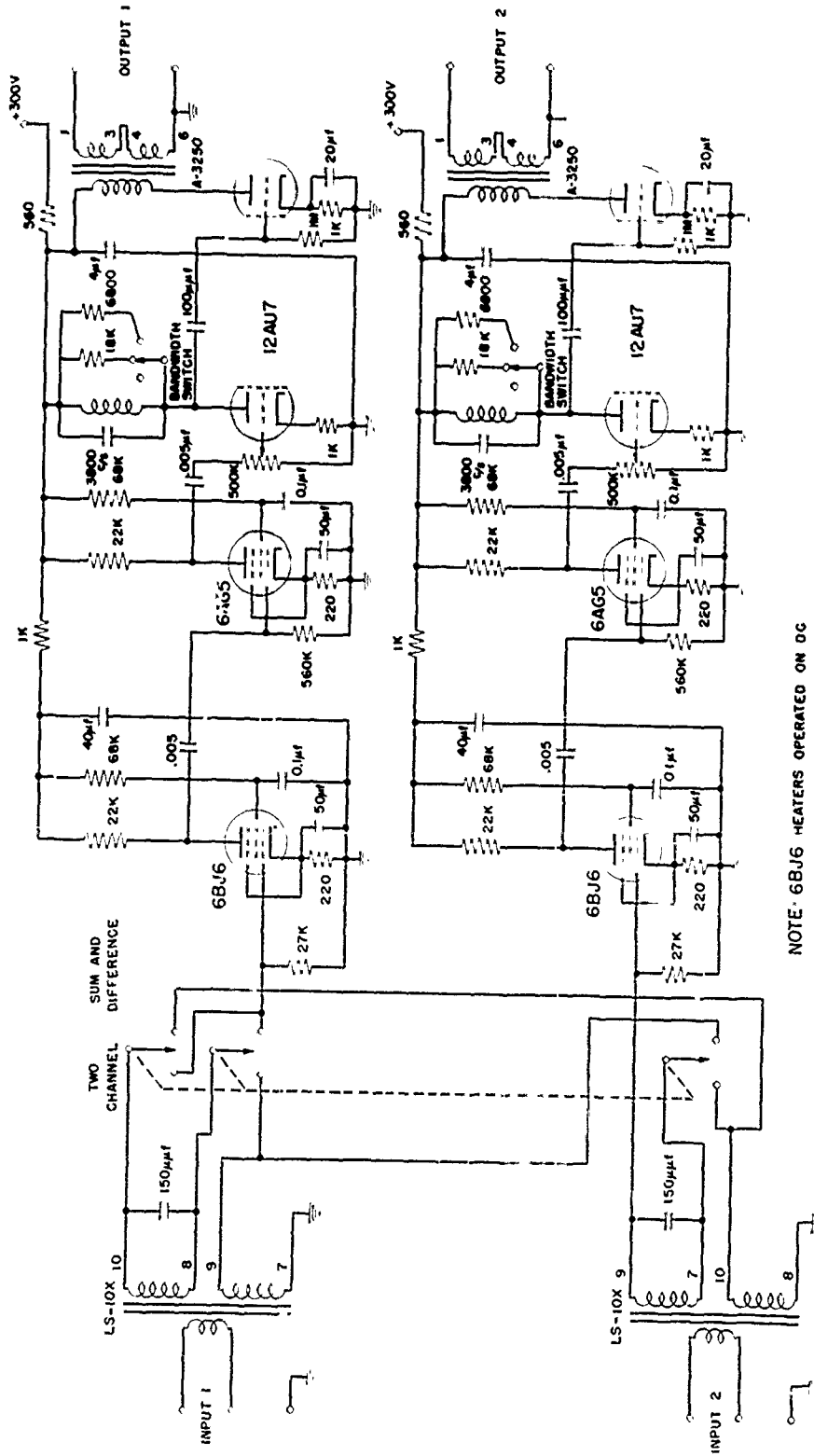
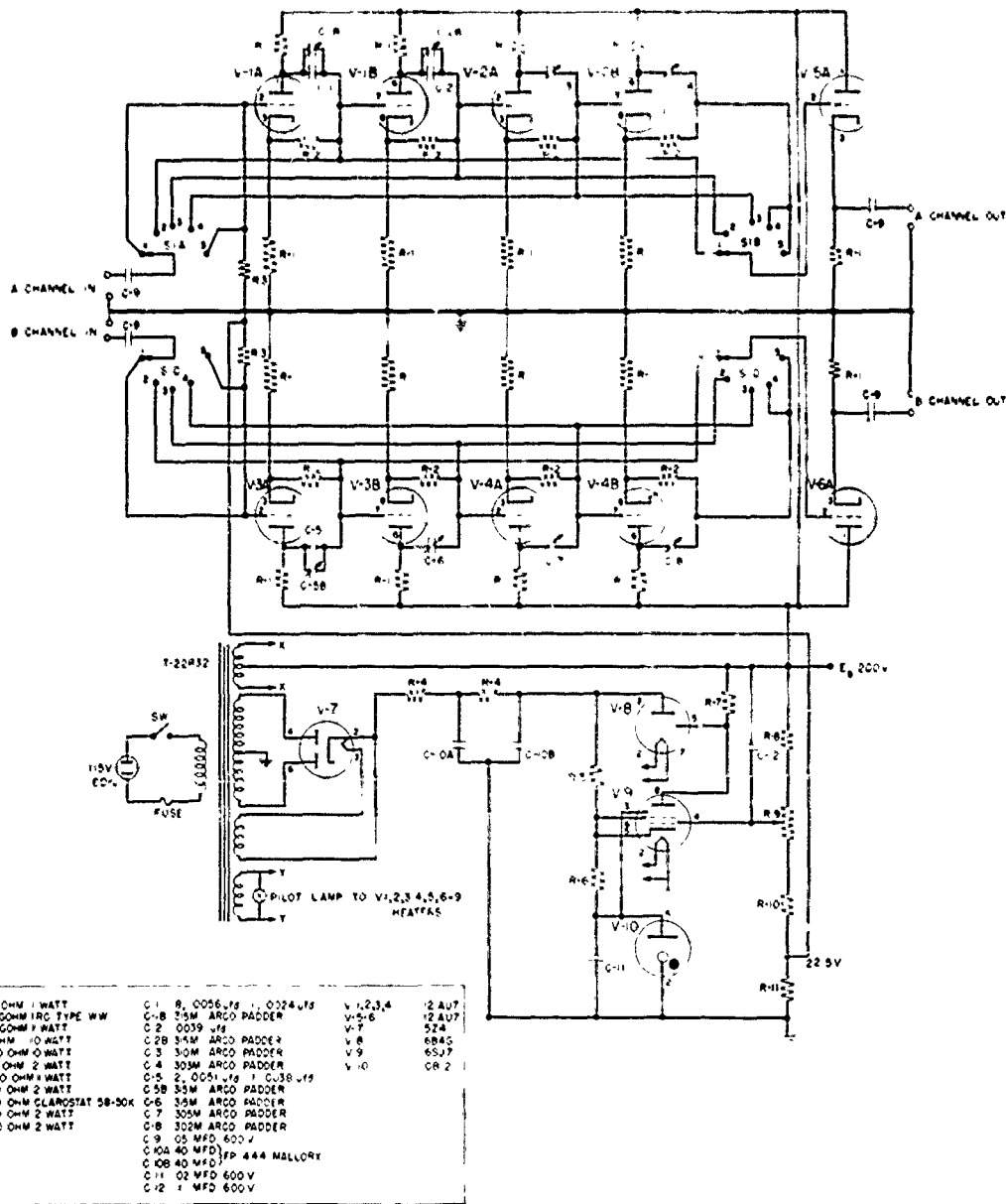

Fig. 2.8. Schematic diagram of twin-channel receiving amplifier.



R-1 5600 OHM 1 WATT	C-1 8.0056-12 0.024 ufs	V-1,2,3,4 12A07
R-2 1/2 MEGOHM IRC TYPE WW	C-2 0.039 ufs	V-5,6 12A07
R-3 10 MEGOHM 1 WATT	C-3 30M ARCO PADDER	V-7 5Z4
R-4 100 OHM 10 WATT	C-4 30M ARCO PADDER	V-8 6B4G
R-5 20000 OHM 0 WATT	C-5 2.0051-12 0.038 ufs	V-9 6S27
R-6 4700 OHM 2 WATT	C-6 35M ARCO PADDER	V-10 CR 2
R-7 220000 OHM 1 WATT	C-7 305M ARCO PADDER	
R-8 33000 OHM 2 WATT	C-8 302M ARCO PADDER	
R-9 50000 OHM CLAROSTAT 5B-50K	C-9 05 MFD 600 V	
R-10 22000 OHM 2 WATT	C-10A 40 MFD 444 MALLORY	
R-11 15,000 OHM 2 WATT	C-10B 40 MFD 600 V	
	C-11 02 MFD 600 V	
	C-12 1 MFD 600 V	

Fig. 2.9. Ninety-degree phase-shifter. The difference between the overall phase shifts in the two channels is 90 degrees.

Nonlinear Signal Processing Devices

The various nonlinear signal processing devices used in most of the experiments were described in the preceding memorandum (TM 27).

Recorder

The outputs (dc plus fluctuation noise) of the various correlators and detectors were plotted automatically on a level recorder.⁴ As mentioned above, the receiving array in the anechoic chamber was rotated by a servo system to follow exactly the horizontal motion of the pen of the recorder. The recorder, therefore, plotted the output of the correlator or detector as a function of the position angle of the array. The frequency response of the recorder was not wide compared to the band-pass of the averaging networks used ($RC = 0.1$ or 1 sec); consequently, it provided a little more filtering action, and the appearance of the output signal in output noise as drawn on the graph by the recorder must not be taken as an absolutely correct representation of the relative amplitudes of signal and noise at the outputs of the various systems.

Output Noise Meter

A specially designed low-frequency square-law voltmeter was devised for measuring the mean-square of the fluctuation noise at the output of the various detectors and correlators under test. This voltmeter has been described previously (TM 27, Chap. III).

References

1. The Design and Construction of Anechoic Sound Chambers, OSRD Report No. 4190, Electro-Acoustic Laboratory, Harvard University, Cambridge, Massachusetts. October 15, 1945). Beranek, L. L. and H. P. Sleeper, Jr., "The Design and Construction of Anechoic Sound Chambers," J. Acoust. Soc. Am. 18, 140-150 (July, 1946).

2. Brown, Robert F., Jr., "Frequency-Independent "RC" Phase Shifter," J. Acoust. Soc. Am. 23, 623A (September, 1951). We are also indebted to Mr. Brown for a private communication of further details of this circuit.
3. Stanford Research Institute, Final Report: Application of Techniques in the Reception of Single-Sideband Transmitted Signals, Stanford, California (March 30, 1951).
4. Miller, F. G., Development of the Type 48-A Power-Level Recorder, Technical Memorandum No. 10, Acoustics Research Laboratory, Harvard University, Cambridge, Massachusetts (August 15, 1949). The recorder has since been provided with a d-c input circuit, giving recording sensitivities from .352 to .0262 v./in. The input impedance of the d-c amplifier is of the order of one megohm, and causes negligible loading of the RC averagers at the outputs of the correlators.

CORRELATION IN NOISE FIELDS

We shall find that in order to compute the output signal-to-noise ratio for various receiving systems we need to evaluate the cross-correlation between the pressures at two different points in a noise field. If the noise field could be specified as due to a prescribed distribution of noise generators of prescribed characteristics, this computation could, in principle, be carried out. The computation is easier, however, for a three-dimensional isotropic noise field, which we define as one in which the power received by a directional receiver in the noise field is independent of either the position in space or the angular orientation of the receiver. This type of background noise model is more useful, also, in comparing, in general terms, various receiving systems. Imagine, for example, a uniform distribution of infinitesimal, statistically independent random noise sources on the inner surface of a very large sphere. If all these sources have the same intensity spectrum, the sound field in the vicinity of the origin may be considered isotropic.* The cross-correlation between the pressures at two different points in such an isotropic noise field can be calculated by integrating the cross-correlation between the pressures produced at those two points by a single point source on the large sphere over all possible positions of the point source on the sphere. This cross-correlation has been derived previously and numerically evaluated for the case of a rectangular spectrum one octave in width.¹ We here derive these results again in somewhat different notation, and evaluate the cross-correlation for tuned-circuit spectra also.

*The above definition is equivalent to the background distribution specified in the standard definition of directivity factor 3.135b in American Standard Acoustical Terminology, American Standards Association, Inc., New York (July 31, 1951).

Cross-correlation in a Three-Dimensional Isotropic Noise Field

We assume that a single point source is located on a large sphere at the spherical coordinate angles θ and ϕ . We assume that this source generates random noise and that the pressure at the origin generated thereby may be represented by the random function $f(t)$. The pressure at a distance d from the origin on the positive z -axis is then $f[t + (d/c) \cos \theta]$, where c is the sound velocity in the medium. If $\rho(\tau)$ is the normalized auto-correlation function of the random function $f(t)$, the normalized cross-correlation of the pressures at these two points is $\rho[\tau + (d/c) \cos \theta]$.

If the isotropic noise field is assumed to have a mean-square pressure of unity in the vicinity of the origin, the contribution to this mean-square pressure from an element of solid angle $\sin \theta \, d\theta \, d\phi$ will be $(1/4\pi) \sin \theta \, d\theta \, d\phi$. The expression for the cross-correlation in the isotropic noise field is then

$$\begin{aligned} P(d, \tau) &= 1/4\pi \int_0^{2\pi} \int_0^\pi \rho(\tau + d/c \cos \theta) \sin \theta \, d\theta \, d\phi \\ &= 1/2 \int_0^\pi \rho(\tau + d/c \cos \theta) \sin \theta \, d\theta. \end{aligned} \quad (3.1)$$

The symbol cap rho (P) is used here to indicate that this cross-correlation function is also normalized in the sense that $P(0,0) = 1$. There are two possible methods of evaluating this integral:

(1) We can introduce the new variable $\tau' = \tau + (d/c) \cos \theta$ so that

$$P(d, \tau) = \frac{c}{2d} \int_{-d/c + \tau}^{d/c + \tau} \rho(\tau') \, d\tau'. \quad (3.2)$$

This formula must be used carefully whenever $\rho(\tau)$ is explicitly a function of $|\tau|$; otherwise its use is convenient whenever the

indefinite integral of $\rho(\tau)$ is easily found.

(2) The autocorrelation function $\rho(\tau)$ may be written as the Fourier transform of the intensity spectrum of $f(t)$:

$$\rho(\tau) = \int_{-\infty}^{\infty} W(\omega) e^{j\omega\tau} d\omega .$$

Since $\rho(\tau)$ is a normalized autocorrelation function, the intensity spectrum $W(\omega)$ above is also assumed to be normalized so that

$$\int_{-\infty}^{\infty} W(\omega) d\omega = 1 . \quad (3.3)$$

Equation (3.1) may then be written

$$\begin{aligned} P(d, \tau) &= 1/2 \int_0^{\pi} \int_{-\infty}^{\infty} W(\omega) e^{j\omega(\frac{d}{c} \sin\theta + \tau)} \sin\theta d\omega d\theta \\ &= \int_{-\infty}^{\infty} W(\omega) \frac{\sin(\omega d/c)}{(\omega d/c)} e^{j\omega\tau} d\omega . \end{aligned} \quad (3.4)$$

This formula is useful when $W(\omega)$ can be written explicitly as an analytic function of ω , in which case it may be readily evaluated by contour integration.

Evaluation for Rectangular Spectrum

The function $P(d, \tau)$ is here evaluated for a rectangular spectrum for the special case $\tau = 0$. The intensity spectrum of the noise field is assumed to have the constant value $1/2 \Delta\omega$ between $\omega_0 - \Delta\omega$ and $\omega_0 + \Delta\omega$, and to be zero everywhere else. From Eq. (3.4) we then have

$$P(d, 0) = \frac{1}{2 \Delta\omega} \int_{\omega_0 - \Delta\omega}^{\omega_0 + \Delta\omega} \frac{\sin(\omega d/c)}{(\omega d/c)} d\omega$$

$$\begin{aligned}
&= \frac{c}{2d\Delta\omega} \int_0^{d/c(\omega_0 + \Delta\omega)} \frac{\sin x}{x} dx - \frac{c}{2d\Delta\omega} \int_0^{d/c(\omega_0 - \Delta\omega)} \frac{\sin x}{x} dx \\
&= \frac{c}{2d\Delta\omega} \left[\text{Si} \left(\frac{\omega_0 d}{c} + \frac{\Delta\omega d}{c} \right) - \text{Si} \left(\frac{\omega_0 d}{c} - \frac{\Delta\omega d}{c} \right) \right] \\
&= \frac{c}{4\pi d \Delta f} \left[\text{Si} \left[\frac{2\pi d}{c} (f_0 + \Delta f) \right] - \text{Si} \left[\frac{2\pi d}{c} (f_0 - \Delta f) \right] \right] \quad (3.5)
\end{aligned}$$

where $\text{Si}(\)$ is the sine-integral function. The function $P(d,0)$ is plotted in Fig. 3.1 for the cases where $2\Delta f = 2f_0/3$ (an octave band), $f_0/2$, and $f_0/8$. The separation, d , between the two points is expressed in terms of the wavelength, λ_0 , at the center frequency, f_0 , of the pass-band. It may be seen that for the two broad-band cases the correlation is very small for separations greater than 1-1/2 wavelengths.

Evaluation for Tuned-Circuit Spectrum

The complete function $P(d,\mathcal{T})$ is now evaluated for the single-tuned circuit spectrum. The intensity spectrum of "white" noise which has been passed through a series-tuned circuit is (normalized to satisfy Eq. (3.3))

$$W(\omega) = \frac{(2\omega_F/\pi)\omega^2}{(\omega^2 - \omega_0^2)^2 + 4\omega^2\omega_F^2} \quad ,$$

where $\omega_0/2\pi$ is the center frequency and $\omega_F/2\pi$ is the half-bandwidth. (See TM 27, Appendix II.)

The function $W(\omega)$ is an analytic function of the complex variable ω having four simple poles, two each in the upper and lower half-planes. If the sine function in the integrand of Eq. (3.4) is written as the sum of two exponentials, the integral may be evaluated by contour integration. On the real axis, $W(\omega)$ is a real, even function of ω , and $[\sin(\omega d/c)] / (\omega d/c)$ is also

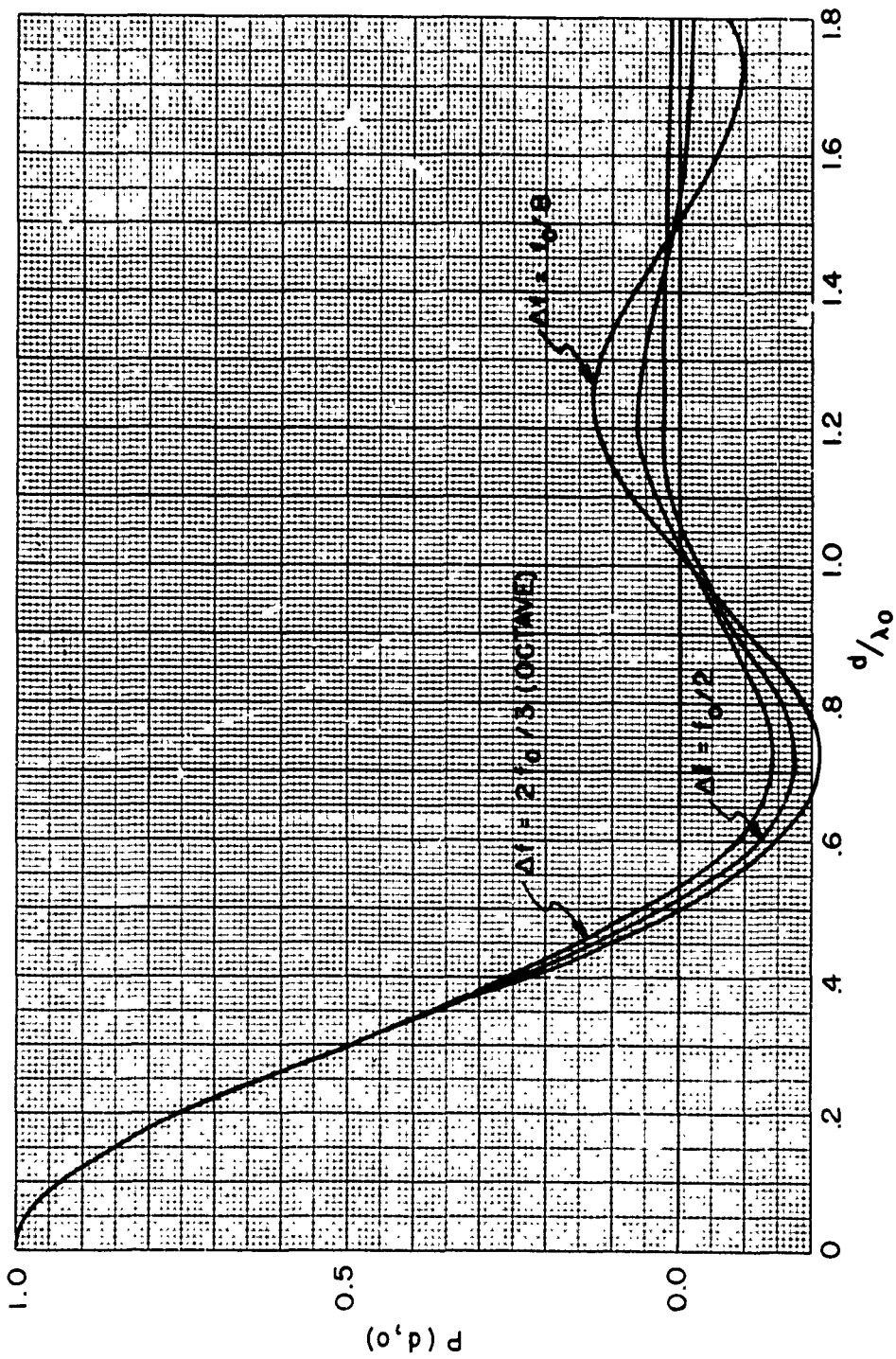

Fig. 3.1. The normalized cross-correlation $P(d, 0)$ between the pressures at two points a distance d apart in a three-dimensional isotropic noise field having a rectangular spectrum whose center frequency is f_0 and half-bandwidth is Δf . λ_0 is the wavelength at the center frequency.

real and even. Since the Fourier transform of a real, even function is also a real, even function, it is only necessary to evaluate $P(d, \tau)$ for negative τ , the values for negative being obtained from

$$P(d, -\tau) = P(d, \tau) .$$

We thus evaluate

$$P(d, \tau) = \frac{\omega_F c}{j\pi d} \left[\int_{-\infty}^{\infty} \frac{W(\omega)}{\omega} e^{j\omega(d/c + \tau)} d\omega - \int_{-\infty}^{\infty} \frac{W(\omega)}{\omega} e^{-j\omega(d/c - \tau)} d\omega \right] .$$

The contour integration is carried out in a straightforward manner, assuming that $\tau \geq 0$, it being noted that the second integral is carried around the lower or upper half-plane depending on whether τ is less than, or greater than, d/c . The result is, for all τ ,

$$P(d, \tau) = \frac{c e^{-\omega_F d/c}}{2d\omega'} \left[e^{-\omega_F |\tau|} \sin \omega' \left(\frac{d}{c} + |\tau| \right) + e^{+\omega_F |\tau|} \sin \omega' \left(\frac{d}{c} - |\tau| \right) \right], |\tau| \leq \frac{d}{c};$$

$$= \frac{c e^{-\omega_F |\tau|}}{2d\omega'} \left[e^{-\omega_F d/c} \sin \omega' \left(\frac{d}{c} + |\tau| \right) + e^{+\omega_F d/c} \sin \omega' \left(\frac{d}{c} - |\tau| \right) \right], \tau \geq \frac{d}{c}, \quad (3.6)$$

where $\omega' = \sqrt{\omega_0^2 - \omega_F^2} = \omega_0 \sqrt{1 - 1/4Q^2}$.

When $\tau = 0$, this cross-correlation function is

$$P(d, 0) = e^{-\omega_F d/c} \frac{\sin(\omega' d/c)}{(\omega' d/c)} . \quad (3.7)$$

This function is plotted in Fig. 3.2 for $Q = 2, 8$, and ∞ . It is the counterpart for the tuned-circuit spectrum of the above result (Eq. (3.5)) for the rectangular spectrum. Again we find that for separations greater than $1.5\lambda_0$ the cross-correlation is negligibly

small, for $Q \leq 8$.

As an example of how $P(d, \tau)$ behaves as a function of τ for $d \neq 0$, there is plotted in Fig. 3.3 the function $P(0.7\lambda_0, \tau)$ for $Q = 8$. It is further obvious that even for separations, d , such that $P(d, 0) = 0$, $P(d, \tau)$ is not everywhere zero.

Cross-correlation in a Two-Dimensional Isotropic Noise Field

The noise field established by the experimental apparatus described in Chapter II is isotropic in only two dimensions, rather than three, since the noise generators are located on a circle rather than over the entire surface of a sphere. For this case, the cross-correlation between the pressures at two points separated a distance d in a (two-dimensional) isotropic noise field is

$$P(d, \tau) = \frac{1}{2\pi} \int_0^{2\pi} p\left(\frac{d}{c} \cos \theta + \tau\right) d\theta,$$

where it is understood that the two points lie in the plane of the circular distribution of noise sources. Introducing the Fourier transform representation of the correlation function we have

$$P(d, \tau) = \frac{1}{2\pi} \int_0^{2\pi} \int_{-\infty}^{\infty} W(\omega) e^{j\omega\left(\frac{d}{c} \cos \theta\right)} e^{j\omega\tau} d\omega d\theta.$$

The θ -integration can be performed easily² with the result that

$$P(d, \tau) = \int_{-\infty}^{\infty} W(\omega) J_0\left(\frac{\omega d}{c}\right) e^{j\omega\tau} d\omega, \quad (3.8)$$

where $J_0(\)$ is the Bessel function of the first kind of order zero. By comparison with Eq. (3.4) we see that in the two-dimensional case the factor $[\sin(\omega d/c)]/(\omega d/c)$ has been replaced by $J_0(\omega d/c)$. These functions are quite similar, the greatest difference being that their zeros do not quite coincide.

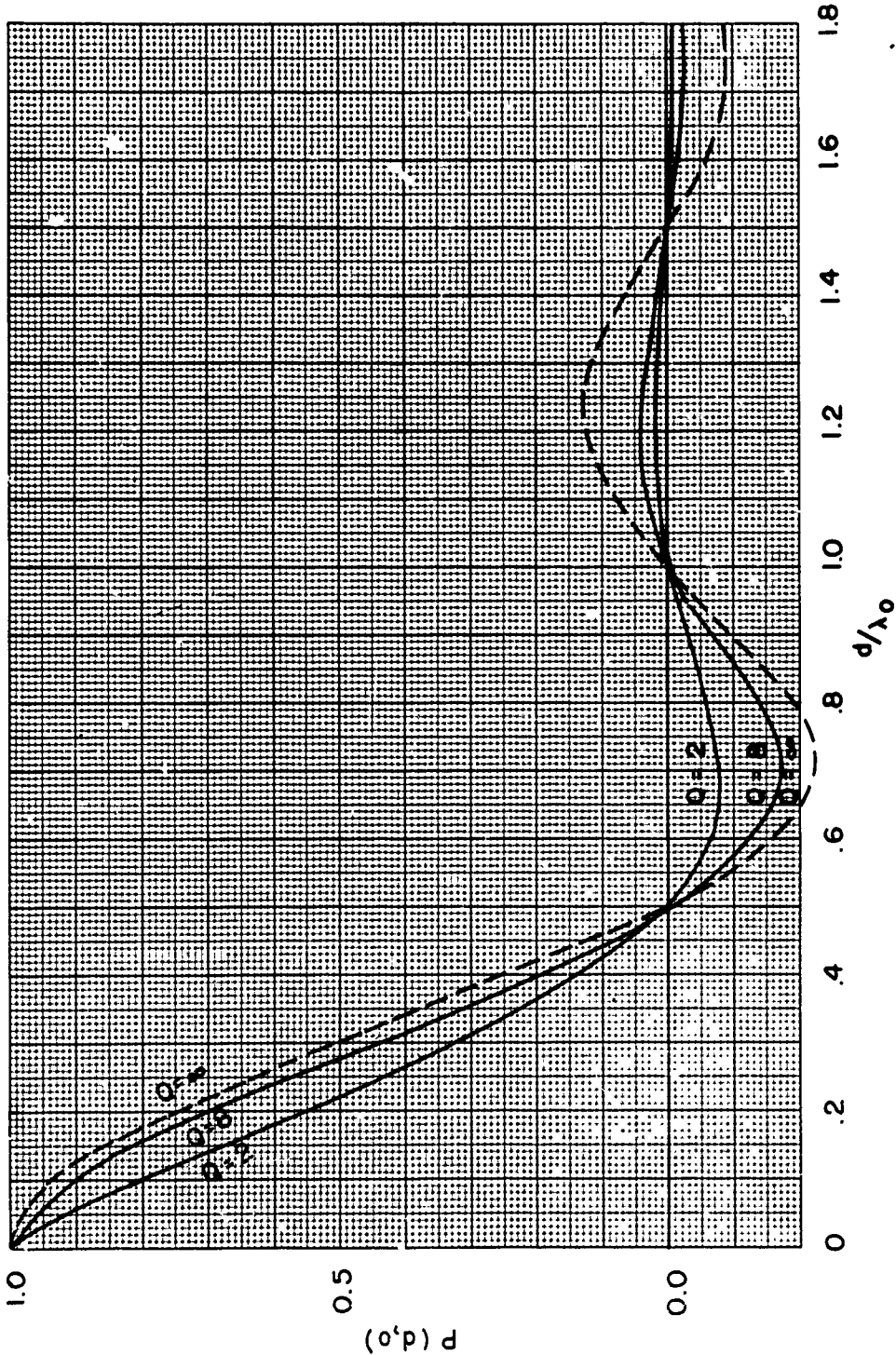

Fig. 3.2. The normalized cross-correlation $P(d,0)$ between the pressures at two points a distance d apart in a three-dimensional isotropic noise field having a tuned-circuit spectrum with various values of Q . λ_0 is the wavelength at the center frequency of the spectrum.

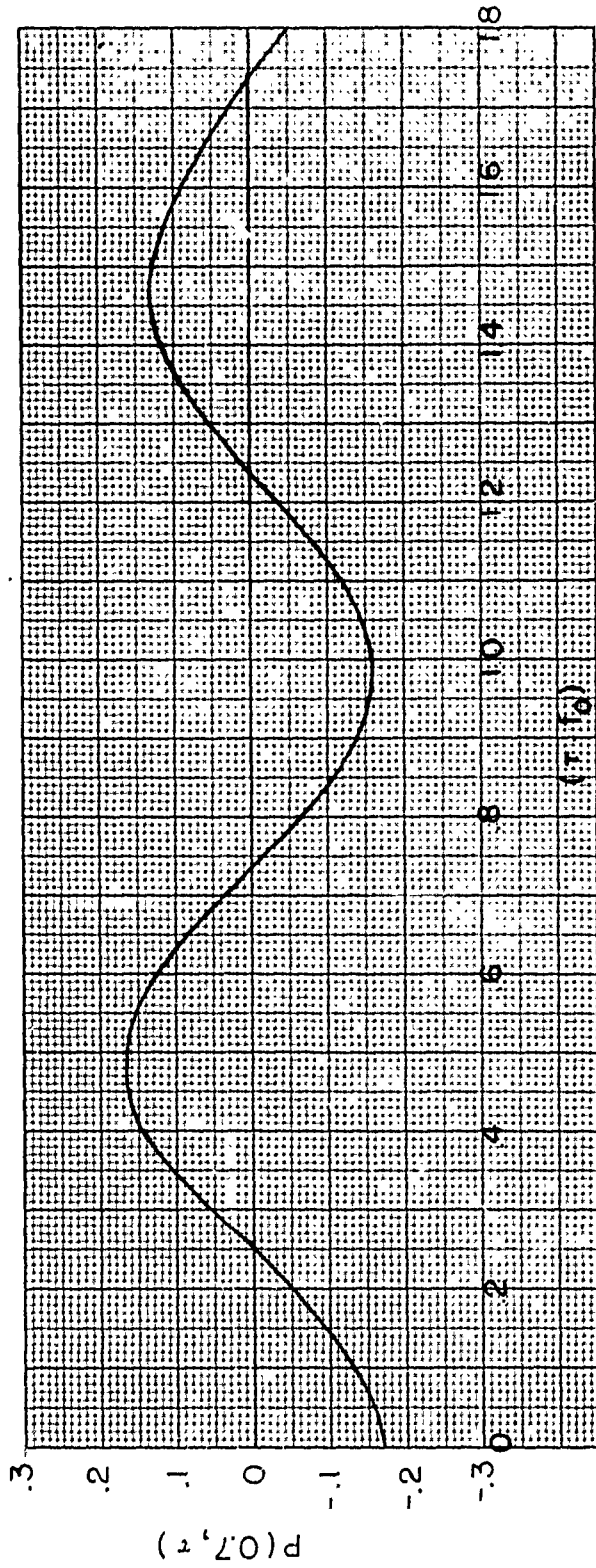

Fig. 3.3. The normalized cross-correlation $P(0.7\lambda_0\tau)$ between the pressures at two points a distance $0.7\lambda_0$ apart in a three-dimensional isotropic noise field having a tuned-circuit spectrum with $Q = 8$. λ_0 is the wavelength at the center frequency of the spectrum.

Because of the similarity of these functions, we conclude that the cross-correlation in the two-dimensional case is very similar to that in the three-dimensional case, although the indicated integration in Eq. (3.8) could only be carried out numerically, with the possible exception of a few special cases.

References

1. Marsh, H. W., Jr. "Correlation in Wave Fields," A declassified portion of the Quarterly Report for the period ending March 31, 1950, U. S. Navy Underwater Sound Laboratory, New London, Connecticut.
2. Jahnke, E., and F. Emde, Tables of Functions, 4th ed., Dover Publications, New York (1945), p. 149.

IV

APPLICATION OF CORRELATION TECHNIQUES TO TWO-ELEMENT ARRAYS

As an introductory example of the application of correlation techniques to an acoustic receiving system, we shall examine in detail the operation of a two-element array where the cross-correlation of the signals received by the two elements is measured with a correlator, and these results are compared with the more conventional arrangement where the signals from the two elements are added and applied to a square-law detector.* A few remarks are in order, first, on the general subject of the conditions for comparison of the two systems, and the methods of making that comparison.

We have under consideration in this memorandum the ability of an acoustic receiving system to detect a signal and to determine the direction of its source in the presence of background noise which arises in the medium (rather than in receiver amplifiers). Comparison is made for the case of a random signal having the same spectrum as the background noise, and having a mean-square pressure in the vicinity of the receiving system small compared with the total mean-square background noise pressure. The signal and the background noise are assumed to be gaussianly distributed functions which are stationary, that is, "on" continuously. Since all correlators or detectors consist of some nonlinear signal-processing device followed by an averaging (smoothing) network, we make comparison where the same averaging network is used in each case, and, in order to conform to many practical cases, as well as to simplify the mathematical treatment, we assume that the effective averaging time of the smoothing network is long compared with the reciprocal of the bandwidth of the input signals.

*While a linear detector might be used in practice, the results of TM 27, Chap. IV, show that for small signal-to-noise ratios, there is little difference in the output signal-to-noise ratio between linear and square-law detectors while mathematical treatment of the latter is much simpler.

We shall see that it is not possible to compute the directional gain of a correlation system by integrating its receiving "beam pattern" or response to a point source. Useful comparison of different systems must be made by computing the signal-to-noise ratio at the output of the detector or correlator for the same signal-to-noise ratio in the medium at the receiver. The output of the detector or correlator will, in general, consist of several components: A steady or d-c component due to the signal; a steady component due to the background noise; a fluctuating component due to the signal; and a fluctuating component due to the background noise. The third of the above will be assumed to be negligibly small compared with the fourth, since we assume that the input signal-to-noise ratio is small. We shall compute signal-to-noise ratios only for the case where the signal source lies on the principal axis of the receiving system, that is, that the receiving system is trained on the signal source. The output mean-square signal-to-noise ratio might then be defined as the ratio of the square of the d-c output due to the signal to the mean-square of the a-c output due to the background noise, ignoring the d-c output due to the background noise which could, in principle, be biased-off. We shall see, however, that it is not strictly correct to include all of the d-c output due to the signal in our definition of the output signal, because in some cases the output signal does not fall to zero as the signal source is removed from the principal axis of the system, and part of the signal, therefore, cannot be distinguished from the direct current due to the background noise. We therefore have chosen to define the output mean-square signal-to-noise ratio as the ratio of the square of that part of the d-c output due to the signal which falls to zero as the signal source is moved farther and farther away from the principal axis of the system to the mean square of the fluctuation at the output due to the background noise. This point will be discussed further in the light of several examples as they arise.

We shall assume that our two-element array consists of two transducers separated by a distance d . We assume that these

transducers measure the total pressure at the point where they are located, that is, that they are equally sensitive to sounds which arrive from any direction.

Two-Element Array with Correlator

Consider first the response of the system indicated in Fig. 4.1 to a signal originating at a distant point source located at an angle θ from broadside to the array. If $s(t)$ is the signal function which would be received at the center of the array, the signals received by the two elements spaced a distance d apart would be $s[t + (d/2c)\sin\theta]$ and $s[t - (d/2c)\sin\theta]$. The average output of the correlator is then $R[(d/c)\sin\theta]$, where $R(\tau) = \overline{s(t)s(t - \tau)}$, the autocorrelation function of $s(t)$. This average output as a function of the angle θ , as measured with the apparatus described in Chapter II, is shown in Figs. 4.2a, 4.2b, and 4.2c. These curves were measured with tuned-circuit spectra having Q 's of 2, 4, and 8 respectively, and with the receivers separated by 6 wavelengths at the center frequency. Obviously, the resolution of the system (sharpness of the pattern) can be greatly improved by increasing the separation, d , of the two receivers above the modest 6 wavelengths which was the maximum we could use with our experimental apparatus. They are unusual beam patterns; a valid directional gain for the system cannot be computed by integrating these curves. We must rather make comparison with other systems in terms of the output signal-to-noise ratio for a given set of input conditions.

To do this, we assume that the receiving system is located in a background noise field, that the signal source is broadside to the array (so that the signals arrive in phase at the two receivers), and that therefore the output of one receiver is $[n_1(t) + s(t)]$ and of the other is $[n_2(t) + s(t)]$. We assume that the background noises $n_1(t)$ and $n_2(t)$ are uncorrelated; we have seen in the previous chapter that if the background noise field were isotropic, this would be true, for tuned-circuit or rectangular spectra, for receiver separations greater than about

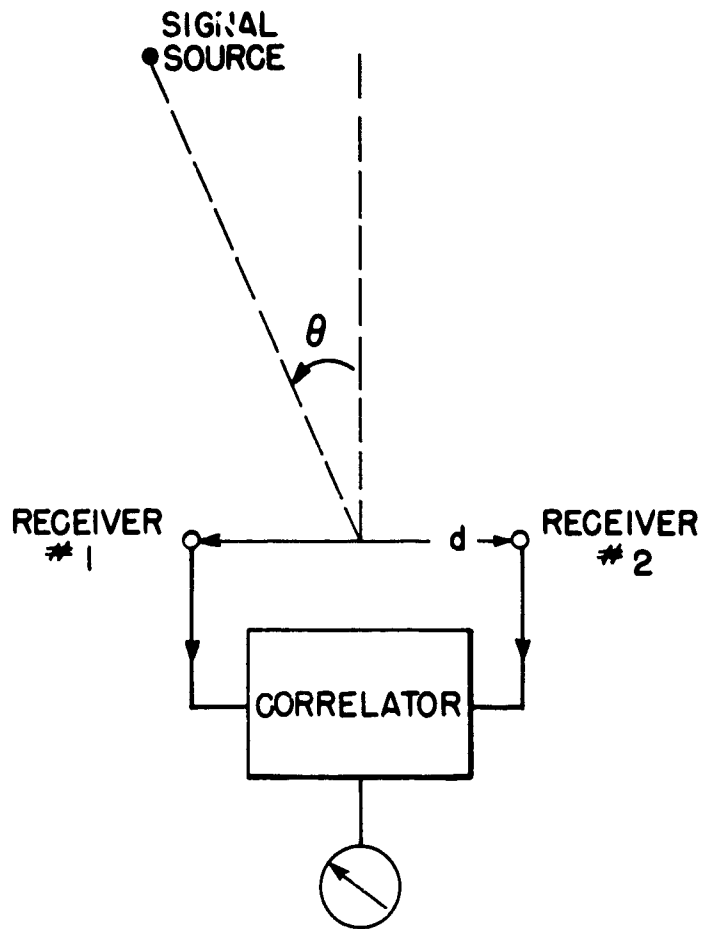

Fig. 4.1. Block diagram of correlation receiving system. The average product of the two received signals is measured by the correlator.

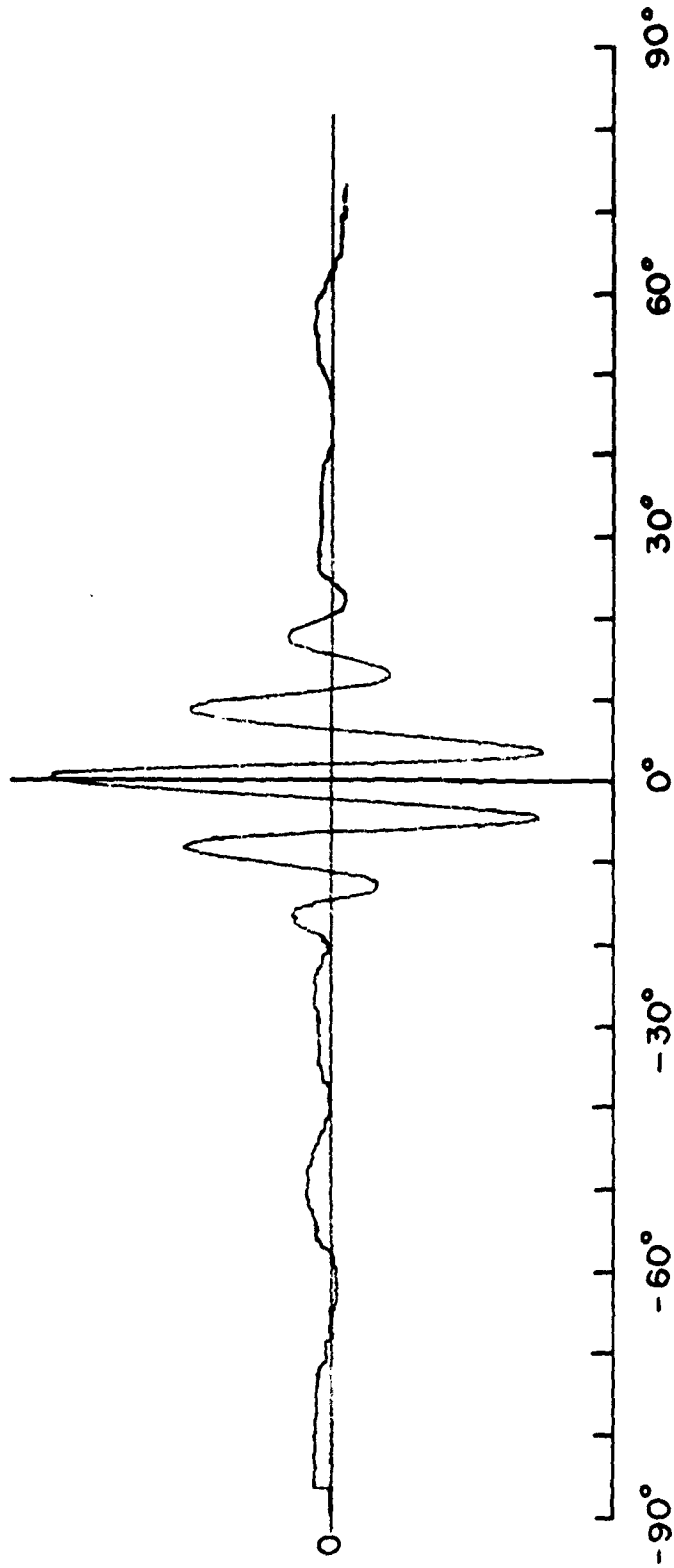

Fig. 4.2a. Response of the system of Fig. 4.1 to a signal source at 0° in the absence of background noise, for a tuned-circuit spectrum with $Q = 2$.

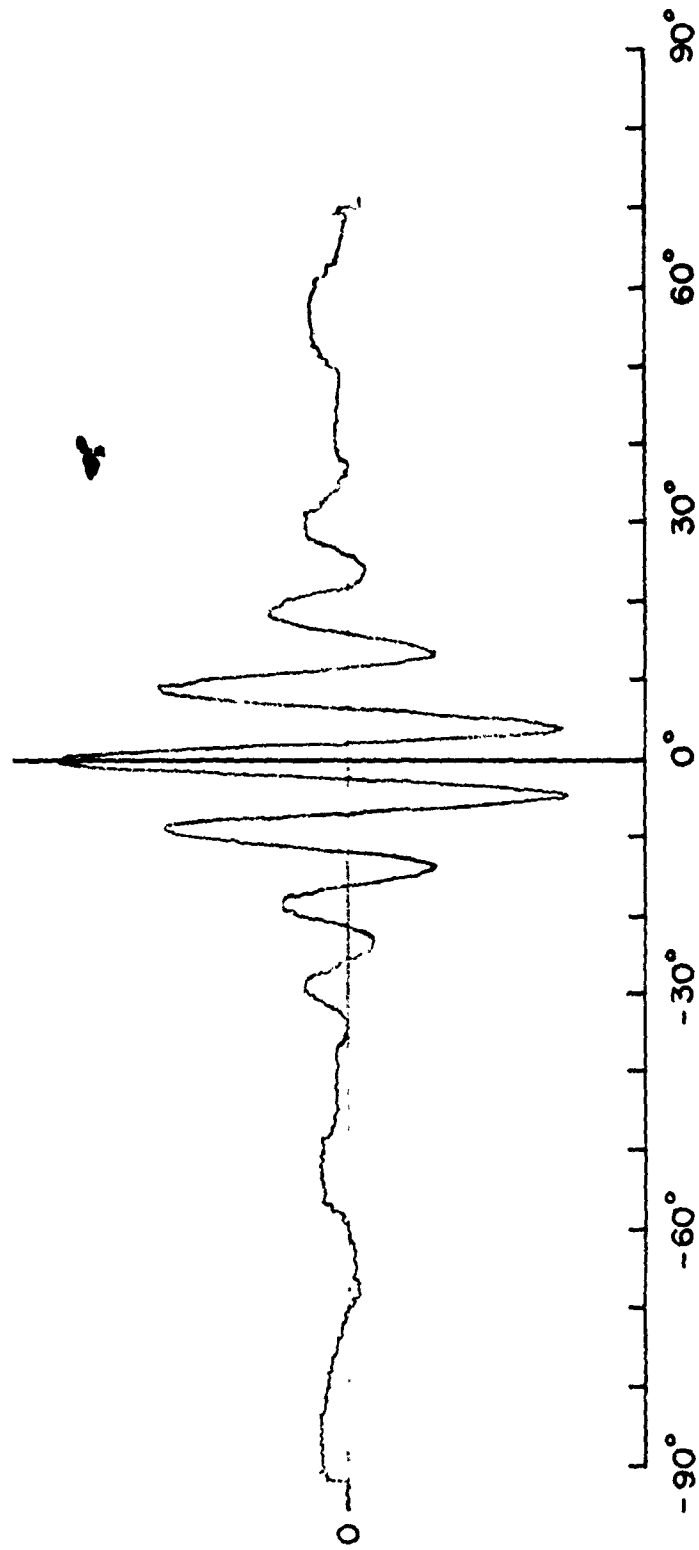

Fig. 4.2b. Response of the system of Fig. 4.1 to a signal source at 0° in the absence of background noise, for a tuned-circuit spectrum with $Q = 4$.

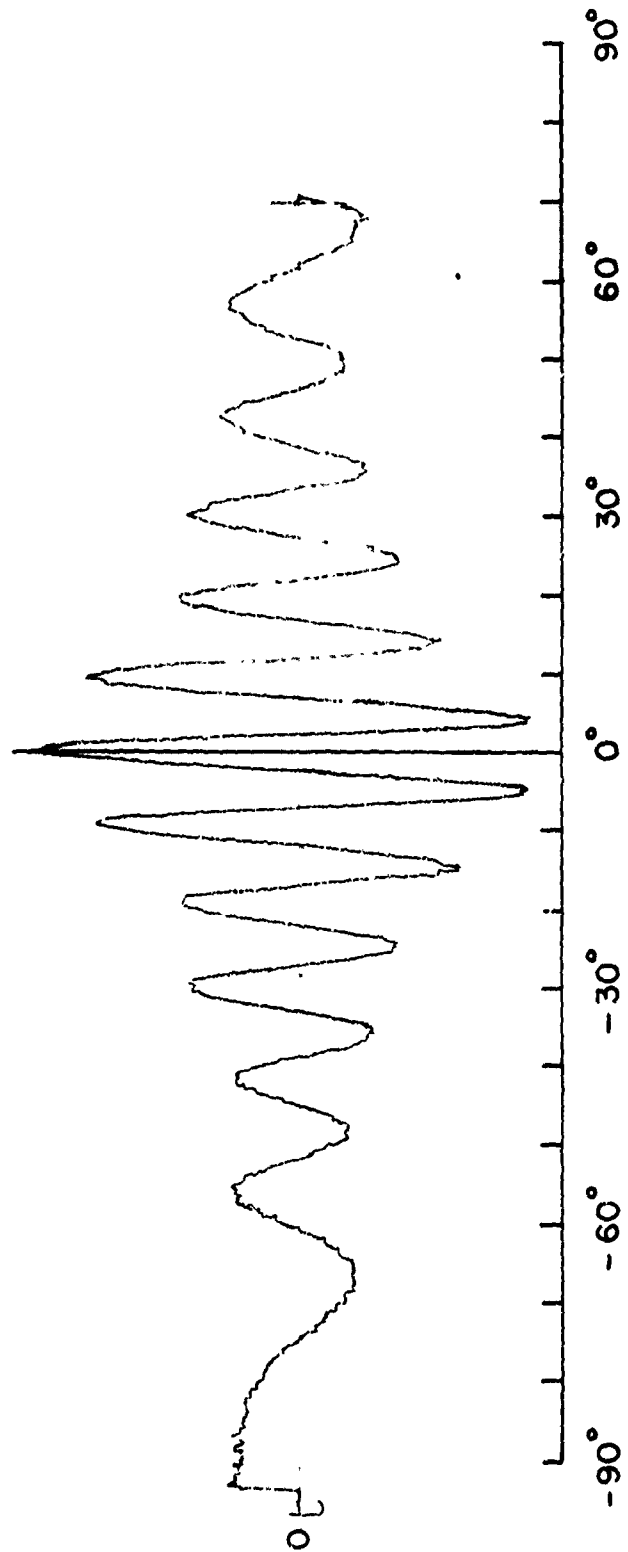

Fig. 4.2c. Response of the system of Fig. 4.1 to a signal source at 0° in the absence of background noise, for a tuned-circuit spectrum with $Q = 8$.

1.5 wavelengths at the center frequency. We write for the mean-square values of the signal and noise, $S = s^2(t)$ and $N = n_1^2(t) = n_2^2(t)$, respectively. Then the input mean-square (power) signal-to-noise ratio at either receiver is $(S/N)_{in}$, and if the correlator uses an RC averaging network, we see from the third entry of Table 2.1 of TM 27 that the mean-square output signal-to-noise ratio would be

$$(S/N)_{out} = 4\omega_p RC (S/N)_{in}^2, \quad (4.1)$$

where ω_p is the angular half-bandwidth of the tuned-circuit spectrum. Because the background noises $n_1(t)$ and $n_2(t)$ are uncorrelated, there is no d-c output due to the background. If they should be correlated, there would be a d-c output whose amplitude would depend upon the degree of correlation. At the same time, the output fluctuation noise would increase, depending upon the degree of correlation, but never more than 3 db, as we can see from the second entry in Table 2.1 of TM 27. In general, such a system as we describe above would be used at relatively large separations of the two receivers, where it would be quite reasonable to assume that the background noises are completely uncorrelated.

Various features of the output of a system of this type are illustrated in Fig. 4.3. This is a photograph of the record drawn by the recorder when the apparatus described in Chapter II was set up to study the two-element array. The horizontal scale is the rotation angle of the receiving array in degrees, and the vertical scale is the voltage output of the correlator. Two Western Electric 633-A microphones were used as the receivers, and were spaced 6 wavelengths apart at the center frequency of the tuned-circuit spectrum. For these curves the receiver amplifier filters were set for $Q = 4$. The correlator used was of the type illustrated in Fig. 3.10 of TM 27, with the RC averager's time constant increased to 1 sec. The straight line is the zero line or the output voltage when no signals were applied to the correlator. When the noise voltages were applied to 36 of the speakers in the back-

ground array, and adjusted so that the sound pressures created at the center of the large array by each speaker were all equal, the output of the correlator was as shown in the "background only" curve. There is no d-c component due to this isotropic background, and we observe here only the fluctuation noise due to this background noise. When a random signal was added to the voltage applied to the speaker located at the angular position 0 degrees in the array, the "background + signal" curve was traced. The input signal-to-noise ratio was - 3 db here and in Fig. 4.5. The output signal is simply the autocorrelation function of the received signal plotted on a slightly distorted abscissa scale [$\tau = \frac{d}{c} \sin\theta$]. Its form as a function of angle can therefore be changed by changing the band-pass of the receiving amplifiers. The envelope of this function, however, decreases most rapidly as a function of angle for the widest bandwidths, and therefore one is limited in narrowing this function by the spectral width of the signal in the medium.

The use of output "signals" of this form, having many positive and negative "minor lobes," may seem strange at first; yet, so long as the signals do not extend so far in angle as to seriously decrease the resolution of the system, the distinctive form of such signals might actually aid one in detecting their presence in noise.

Two-Element Array with Square-Law Detector

Suppose now that the signals from these two point receivers are added and applied to a square-law detector, as indicated in Fig. 4.4. We again compute first the response of this system to a signal in the absence of background noise. If the signal source is located at an angle θ from broadside to the array, the signals received by the elements are $s[t + (d/2c)\sin\theta]$ and $s[t - (d/2c)\sin\theta]$, as before. The average output of the square-law detector is the average of the square of the sum of these signals:

$$\left[s\left(t + \frac{d}{2c} \sin\theta\right) + s\left(t - \frac{d}{2c} \sin\theta\right) \right]^2$$

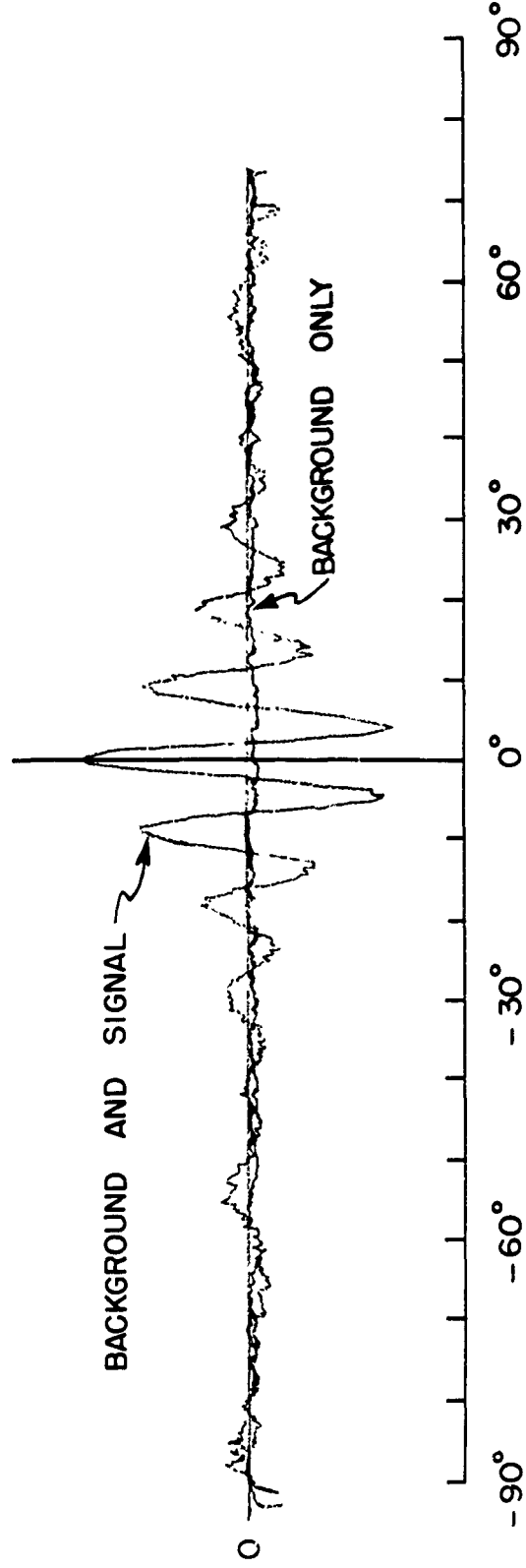

Fig. 4.3. Output of the system of Fig. 4.1 for background noise only, and for background noise plus a signal at 0° . Tuned-circuit spectrum with $Q = 4$.

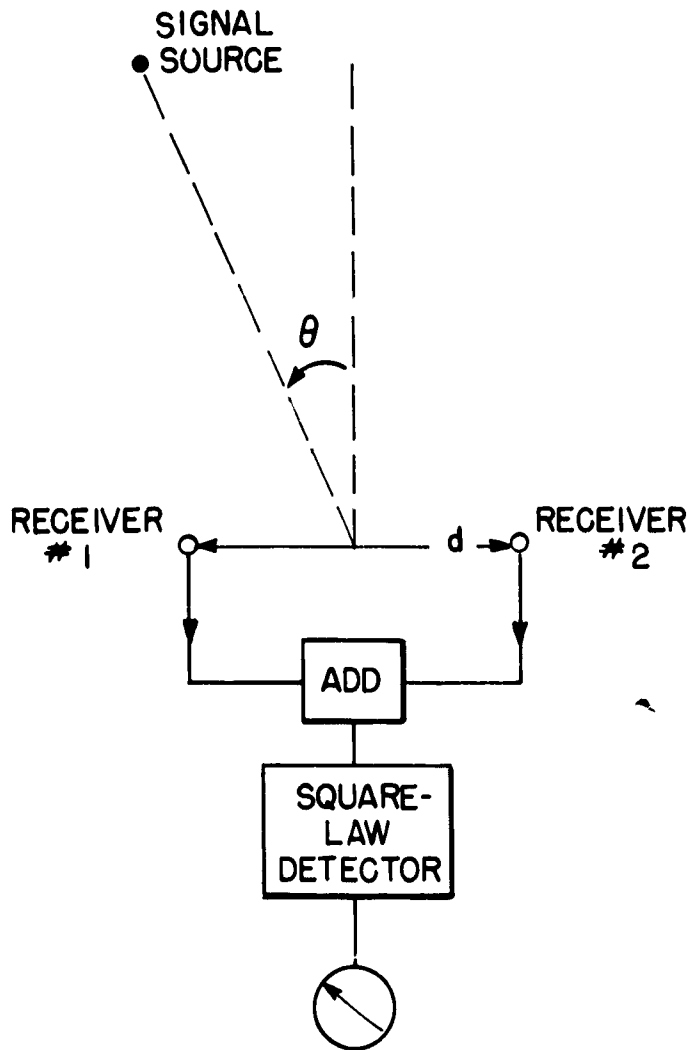

Fig. 4.4. Block diagram of more conventional system for processing signals from a two-element array. The sum of the two received signals is rectified and averaged by the square-law detector.

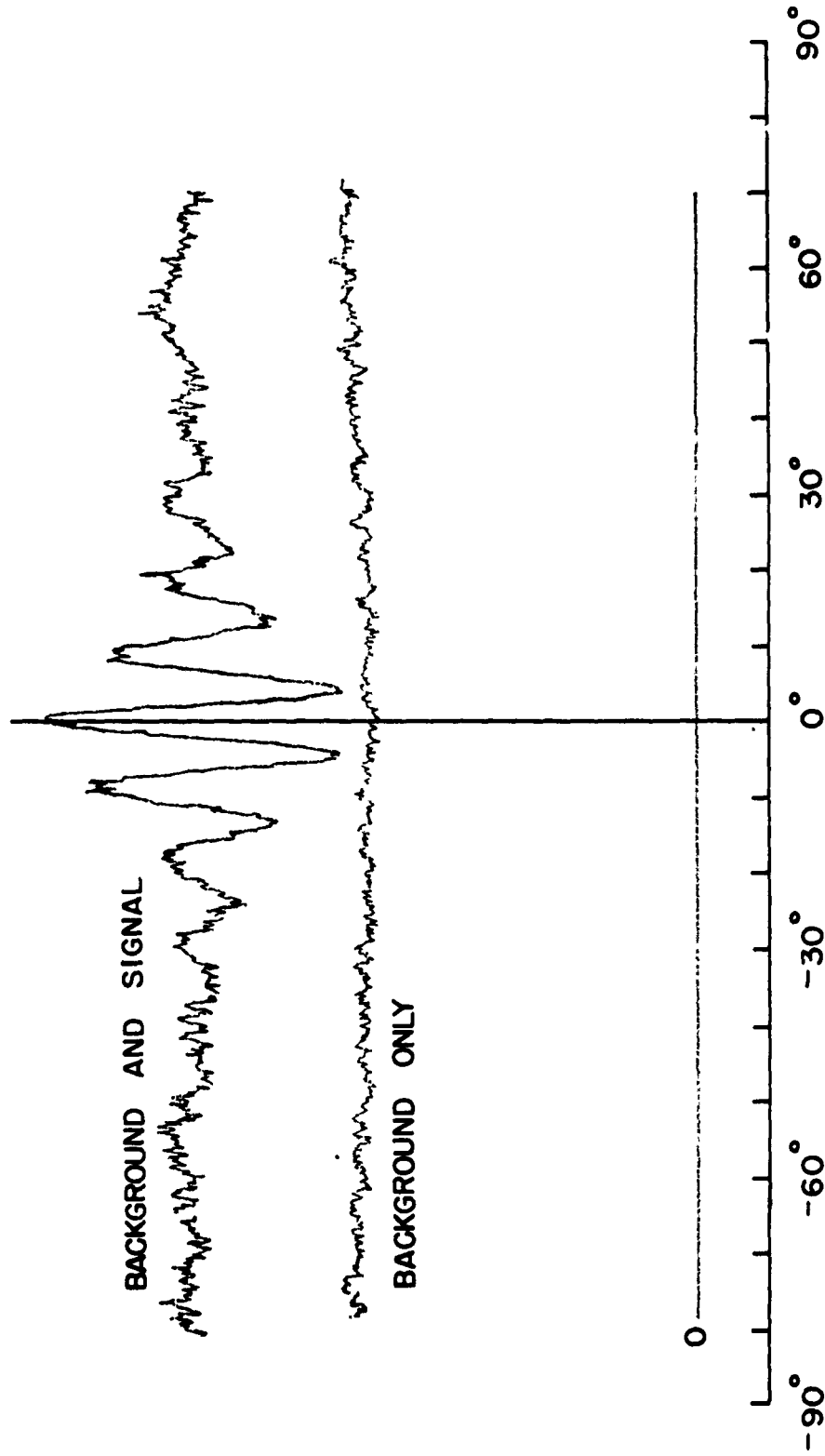

Fig. 4.5. Output of the system of Fig. 4.4 for background noise only, and for background noise plus a signal at 0°. Tuned-circuit spectrum with $Q = 4$. It is apparent here that the response of this system to a signal does not fall to zero as the signal source is moved in angle away from the principal axis.

$$\begin{aligned}
 &= s^2\left(t + \frac{d}{2c} \sin\theta\right) + 2s\left(t + \frac{d}{2c} \sin\theta\right)s\left(t - \frac{d}{2c} \sin\theta\right) + s^2\left(t - \frac{d}{2c} \sin\theta\right) \\
 &= 2R(0) + 2R\left(\frac{d}{c} \sin\theta\right).
 \end{aligned}$$

There is, in this case, a part, $[2R(0)]$, of the response to a signal which is not a function of θ , and therefore the response does not fall to zero as the signal source is moved away from the principal axis of the system. There is also, when there is a background noise, a d-c component of the output equal to twice the mean-square of the background noise picked up by either receiver, assuming that the background noise voltages are equal in amplitude and uncorrelated. The response of this system to background noise and signal is shown in the experimentally measured curves of Fig. 4.5. The conditions were the same as for the curves of Fig. 4.3. The same correlator was used as a square-law detector by connecting its two inputs in parallel. The straight line marked "0" is the zero output of the square-law detector when no input signals are applied. The upper curves were recorded with background noise only, and with background noise and signal. The presence of a part of the response due to the signal that is not a function of angle is clearly seen. In the case of a signal which is "on" continuously, one would have only the upper curve to observe. The maximum amplitude of the signal (maximum departure from the average) on this curve is just $2R(0)$, rather than the maximum total output due to the signal which is $4R(0)$, and we therefore take as the signal, for the purposes of specifying the output signal-to-noise ratio, only the part $2R[(d/c)\sin\theta]$. In the case of a signal which could be turned off periodically, one would indeed be able to measure the total maximum deflection due to the signal, $4R(0)$, but one would also receive the part $2R(0)$ of the response due to the signal, even when the source is at an angular position far removed from the principal axis of the system. Thus the only part of the signal which would carry any information as to the angular position of the source is

$2R[(d/c)\sin\theta]$, and for this case, also, it is reasonable to take as the maximum signal just $2R(0)$.

Keeping this in mind, and proceeding carefully, we can now estimate the output signal-to-noise ratio for this system from Table 2.1 of TM 27. If we again assume that the background noises received by the two elements are incoherent, the signal-to-noise ratio in the sum (at the input to the square-law detector) will be twice that in the medium, or $2(S/N)_{in}$. According to Table 2.1 of TM 27, then, the output signal-to-noise ratio for the tuned-circuit spectrum and an RC averager should be $8\omega_F RC(S/N)_{in}^2$, for small input signal-to-noise ratios. However, because only half of the output voltage due to the signal can be counted as useful signal, the output power signal-to-noise ratio must be reduced by a factor of 2^2 , and the effective output signal-to-noise ratio for the square-law detector is then

$$(S/N)_{out} = 2\omega_F RC(S/N)_{in}^2. \quad (4.2)$$

For this simple system, then, the correlator has an advantage of 3 db in output signal-to-noise ratio, for small input signal-to-noise ratios, when the spacing of the elements is sufficiently wide (as it would be in a practical system). The effective directional patterns of the two systems are identical. No change in beam width or resolution of the system is brought about by the use of the correlator. The pattern is simply the autocorrelation function of the received signal, and thus may be more or less extended in angle depending upon the spectrum and the spectral width of the signal. The correlation system possesses, in addition, the further advantage that there is no large d-c component of the output due to the background noise. If a high-gain recorder were used to record the output of the square-law detector system, it would be necessary to use batteries to bias out this d-c component so that it would be possible to take a close look at the fluctuation noise and possible small signals. If the amplitude of the background should change in

time, the biasing voltage would also have to be adjusted, or the recorder would be driven off scale. No such adjustments would be necessary with the correlation system. This operational advantage might well be more important than the signal-to-noise ratio improvement afforded by the correlation system.

Measurements of output signal-to-noise ratios for these systems have been made by the methods described in Chapter III of TM 27 for comparison with the theoretically predicted values computed from the measured input signal-to-noise ratios. The RC averager time constant was adjusted to 0.100 sec and all three receiver bandwidths were used. All measurements were made for input signal-to-noise ratios of -10 db. The input signal-to-noise ratio was determined and adjusted by measuring the output of a single microphone at the center of the background array when only the background noise was turned on, and then when only the signal was turned on. The measured signal-to-noise ratios and those computed from Eqs. (4.1) and (4.2) for both the correlator system and the square law-detector system are presented in Table 4.1 below:

Table 4.1

Measured and Computed Output Signal-to-Noise Ratios for Correlator and Square-Law Detector Used with Two-Element Array. Tuned circuit spectra, RC = 0.100 sec. averager, input signal-to-noise ratio -10db.				
Spectrum Q	Correlator		Square-Law Detector	
	Computed	Measured	Computed	Measured
2	12.9 db	12.0 db	9.9 db	9.0 db
4	9.8	7.0	6.8	4.0
8	6.4	4.5	3.4	2.0

The discrepancies apparent in this table may be attributed in part to experimental errors and the limiting accuracy of the measuring instruments used, and in part to the fact that the spectrum is not exactly the same as we have assumed in making

the computations (See Fig. 2.3). The measured results have been rounded off to the nearest half-decibel; they show much better agreement with theory in the comparison of the two systems than in the absolute values of the results. They are sufficiently well in agreement with the theory to provide definite corroboration of the theoretical predictions.

Two-Element Array with 90-Degree Phase Shift

If the signal from one of the two elements is shifted 90 degrees in phase at all frequencies with respect to the other signal before the signals are correlated, as indicated in Fig. 4.6, the resultant pattern (response to a point source) is an odd function of angle. Suppose that the two signals received from a point source located at an angle θ from broadside are $s(t + \tau/2)$ and $s(t - \tau/2)$, where $\tau/2 = (d/2c)\sin\theta$. These signals may be represented by a Fourier series expansion (TM 27, Eq. 1.6)) as

$$s(t + \tau/2) = \sum_{n=1}^{\infty} [a_n \cos\omega_n(t + \tau/2) + b_n \sin\omega_n(t + \tau/2)]$$

and

$$s(t - \tau/2) = \sum_{n=1}^{\infty} [a_n \cos\omega_n(t - \tau/2) + b_n \sin\omega_n(t - \tau/2)].$$

If the first of these is delayed in phase by 90 degrees at all frequencies it becomes

$$s_{90}(t + \tau/2) = \sum_{n=1}^{\infty} [a_n \sin\omega_n(t + \tau/2) - b_n \cos\omega_n(t + \tau/2)].$$

As we have seen (Eq. (1.9) of TM 27), the cross-correlation of $s(t + \tau/2)$ and $s(t - \tau/2)$ is

$$R(\tau) = \langle a_n^2 \rangle \sum_{n=1}^{\infty} \cos\omega_n \tau.$$

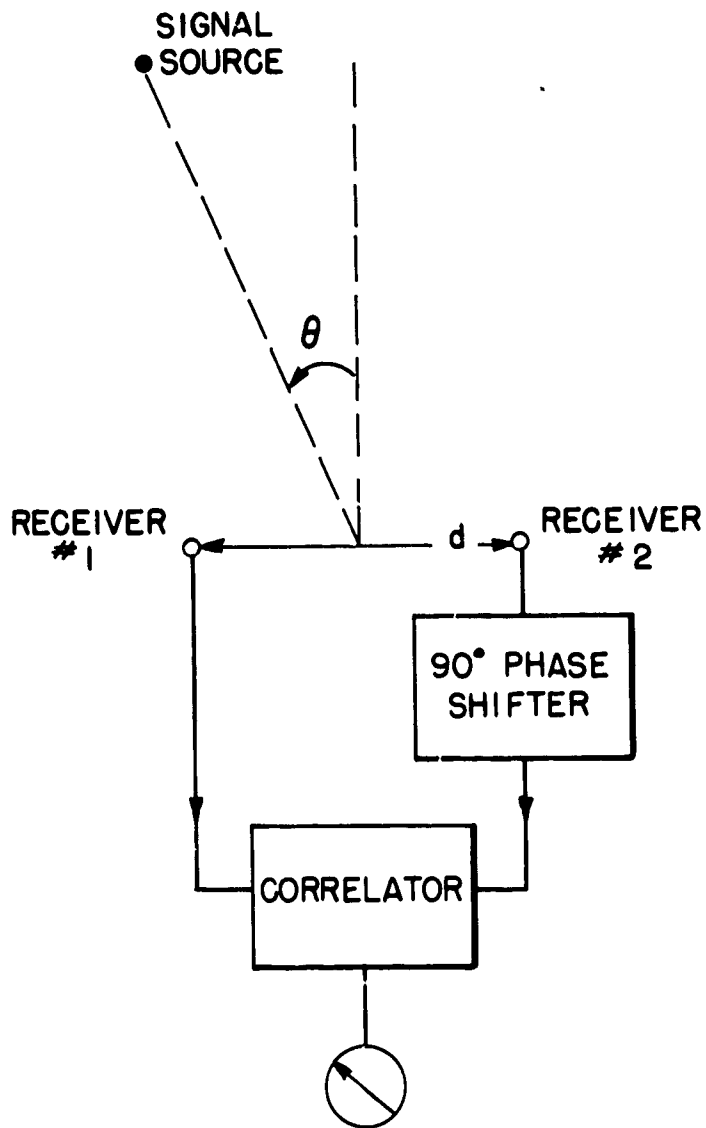

Fig. 4.6. Block diagram of correlation receiving system with 90-degree phase-shifter for accurate determination of direction of source.

We now compute the cross-correlation of $s_{90}(t + \tau/2)$ and $s(t - \tau/2)$:

$$\begin{aligned}
 R_{90}(\tau) &= \sum_{n=1}^{\infty} \overline{[a_n^2 \cos \omega_n(t - \tau/2) \sin \omega_n(t + \tau/2)]} \\
 &\quad - \overline{a_n b_n \cos \omega_n(t - \tau/2) \cos \omega_n(t + \tau/2)} \\
 &\quad + \overline{a_n b_n \sin \omega_n(t - \tau/2) \sin \omega_n(t + \tau/2)} \\
 &\quad - \overline{b_n^2 \sin \omega_n(t - \tau/2) \cos \omega_n(t + \tau/2)} .
 \end{aligned}$$

Using the relations of Eq. (1.7) of TM 27 and performing the indicated averaging, the above reduces to

$$R_{90}(\tau) = \langle a_n^2 \rangle \sum_{n=1}^{\infty} \sin \omega_n \tau .$$

This is clearly an odd function of τ , and is zero for $\tau = 0$. A response curve of the system of Fig. 4.6, measured with the experimental apparatus with conditions other than the inclusion of the wideband 90-degree phase-shifter the same as for the curve of Fig. 4.3 is included as Fig. 4.7. Because this pattern rises or falls sharply from zero as the angular position of the source is moved away from 0 degrees an accurate determination of the zero crossing of this pattern should provide an accurate determination of the angular position of the source. Furthermore, there is absolutely no d-c response to a uniform background noise, at any spacing. The response pattern of this system is reminiscent of various BDI schemes devised during the war for accurate bearing determination.¹ Because the system described above uses a correlator (a true multiplier-averager), there is no change in the symmetry of the pattern and no shift of the zero position due to variations in the relative gains of the

two channels between the transducers and the correlator. Some BDI systems have had to be very carefully designed and constructed to maintain equal gains in both channels to avoid these difficulties. The signal-to-noise ratio for this system is virtually unchanged by the addition of the phase-shifter if one takes as the amplitude of the signal the maximum height of the peaks adjacent to the center of the pattern. It is conceivable that a 90-degree phase-shifter might be provided with a two-element array correlation system, and arranged so that it might be switched in and out of the circuit at the will of the operator.

Two-Element Array with Directional Receivers

The use of a correlator with a two-element array of directional receivers has also been considered and compared with the sum-and-square-law-detector system. A very similar arrangement has been described for radio astronomy by Ryle.² His system makes use of a switch which alternately connects the sum and the difference of the signals received by two wide-spaced directional arrays to the input of a detector, and another synchronized switch which acts as a phase-sensitive detector at the output. The system thus resembles a "single-channel" correlator such as is shown in Fig. 3.12 of TM 27, and measures the correlation between the signals received by the two directional arrays. The detector in actual practice is probably linear rather than square-law, in which case the system is different in operation from a multiplier-averager by only as much as is the linear rectifier correlator (Chap. V, TM 27). As Ryle points out, because such a system is very insensitive to background noise from a distributed source, it is possible to use much greater recorder sensitivity than in the sum-and-square-law-detector system, making the detection of much weaker sources possible with the correlation system.

Our investigation of systems of this kind has been chiefly experimental. General Electric S1203D-7 12-in. loudspeakers were used as the directional receiving transducers. The space behind the cone of these speakers was stuffed with PF Fiberglas

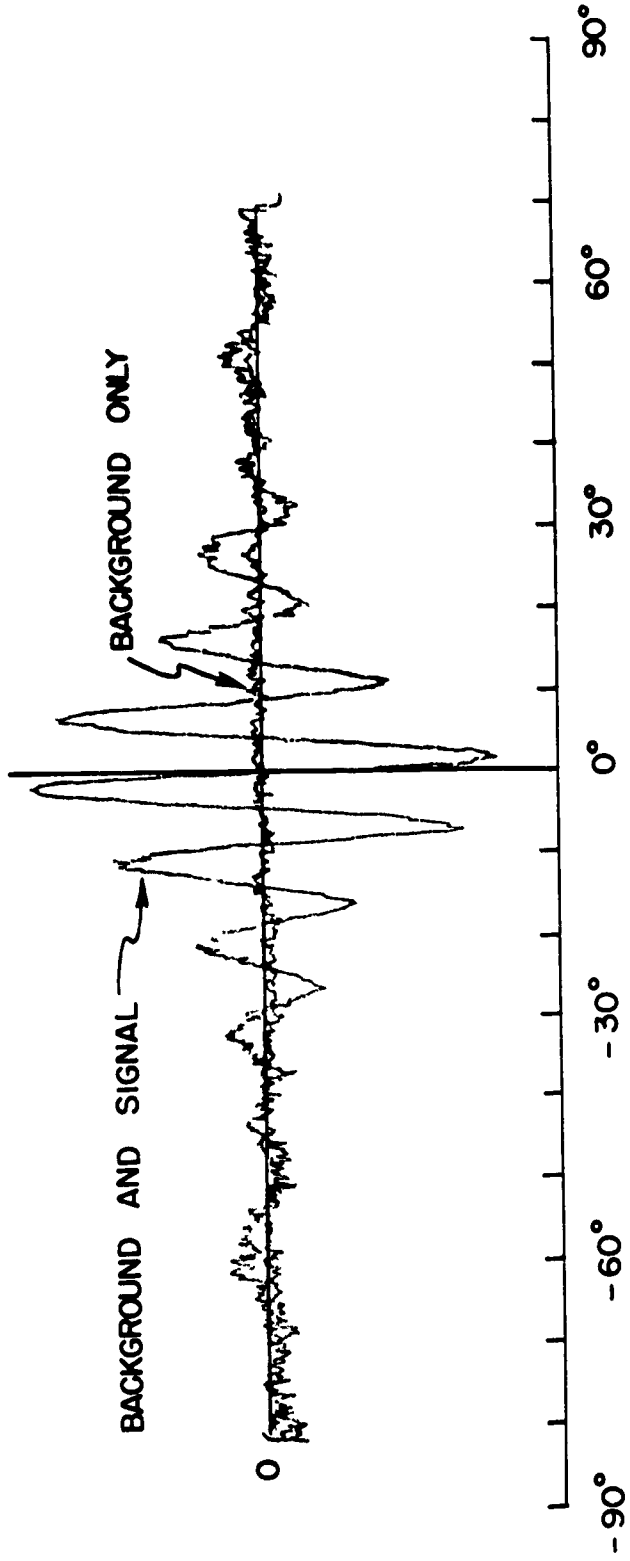

Fig. 4.7. Output of the system of Fig. 4.6 for background noise only, and for background noise plus a signal at 0°. Tuned-circuit spectrum with $Q = 4$.

to provide additional damping in an attempt to smooth the response in the operating frequency range. This treatment was very beneficial but not completely successful. The intensity pattern of one speaker for the tuned-circuit spectrum with $Q = 4$ is shown in Fig. 4.8. The curves of Figs. 4.9 and 4.10 were measured for the same spectrum with two speakers separated 6 wavelengths center-to-center at the center frequency using the cross-correlation system and the sum-and-square-law-detector system, respectively. The three curves show the zero output of the correlator or detector with no input signals, the response to the uniform background noise, and the response to the background noise plus a signal. With this separation and spectrum, the background noises received by the two speakers are seen in Fig. 4.9 to be essentially uncorrelated, because of the absence of the d-c response to the background. However, because these speakers are most sensitive to background noises coming from the same direction, the possibility of the background noises being correlated to some degree is much greater. In order to realize the advantage of having no response to the background noise with directional receivers, it is to be expected that one must use greater separations than in the case of nondirectional receivers.

The directional gain in a two-dimensional isotropic noise field obtained by integrating the pattern of Fig. 4.8 over 180 degrees is 7.5 db; we expect, therefore, that with the speaker pointed at the signal source, there should be an improvement of 7.5 db in the signal-to-noise ratio at the receiver. If these signals are correlated, then, there should be an increase of 15 db in the output signal-to-noise ratio. For the correlation system with $Q = 4$, an input signal-to-noise ratio of -10 db, and an RC averager with $RC = 0.1$ sec, the output signal-to-noise ratio should be (from Table 4.1) $9.8 + 15.0 = 24.8$ db. The experimentally measured output signal-to-noise ratio for this system, with the speakers separated 6 wavelengths at the center frequency of the spectrum, was 21.2 db. (Because of the high

signal-to-noise ratio at the correlator, the output noise in the measurement was taken to be that in the absence of the signal, to correspond to the use of the simplified formula, above. To compute the signal-to-noise ratio in the presence of a large signal, we must take into account the contribution to the fluctuation noise due to the signal (See Chap. II, TM 27).) The discrepancy between the measured value and the theoretical value is probably due to the double distortion of the spectrum by, first, the small speakers in the background array, and, second, the 12-in. speakers used as receivers. The effective narrowing of the spectrum simply increases the relative fluctuation at the output of the averager.

When this array is used with sum-and-square-law detection, the response to a signal source does fall to zero as the source is removed from the principal axis, as we see From Fig. 4.10, and we take as the maximum received signal the total deflection due to the signal. The 6 db which we subtracted from the predicted output signal-to-noise ratio to obtain the value in Table 4.1 for two nondirectional receivers need not be subtracted in this case. The predicted output signal-to-noise ratio for the sum-and-square-law system is then, all else being the same, $12.8 + 15.0 = 27.8$ db. The measured output signal-to-noise ratio for these conditions was 23.5 db. There is again the same discrepancy in the absolute value, but the 3-db superiority of the square-law detector system is clearly demonstrated. In the case of directional receivers, then, where the response to a signal falls to zero as the source is moved away from the principal axis of the receiving system, there is a 3-db advantage in using the square-law system over using the correlator! With this system, however, it is necessary, in order to be able to use a high recorder or indicator gain, to balance out the d-c component of the response of the system to the background noise, and while this is quite possible in a laboratory situation, where the background noise is stationary, it could be inconvenient or even impossible in a practical application. Thus, in the case of a system of this

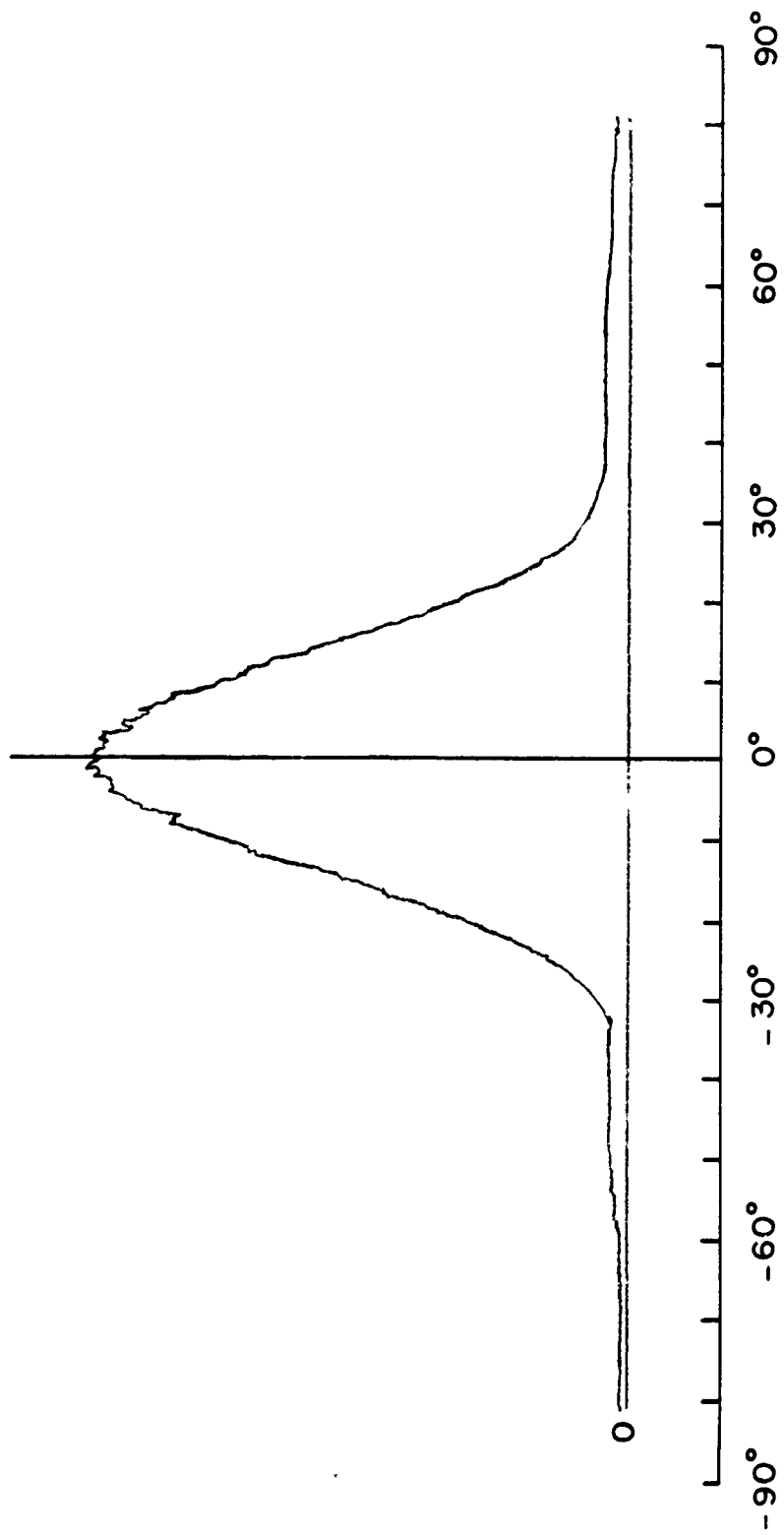

Fig. 4.8. Intensity response pattern for one General Electric SL203D-7 12-in. loudspeaker used as a receiver. Tuned-circuit spectrum with $Q = 4$.

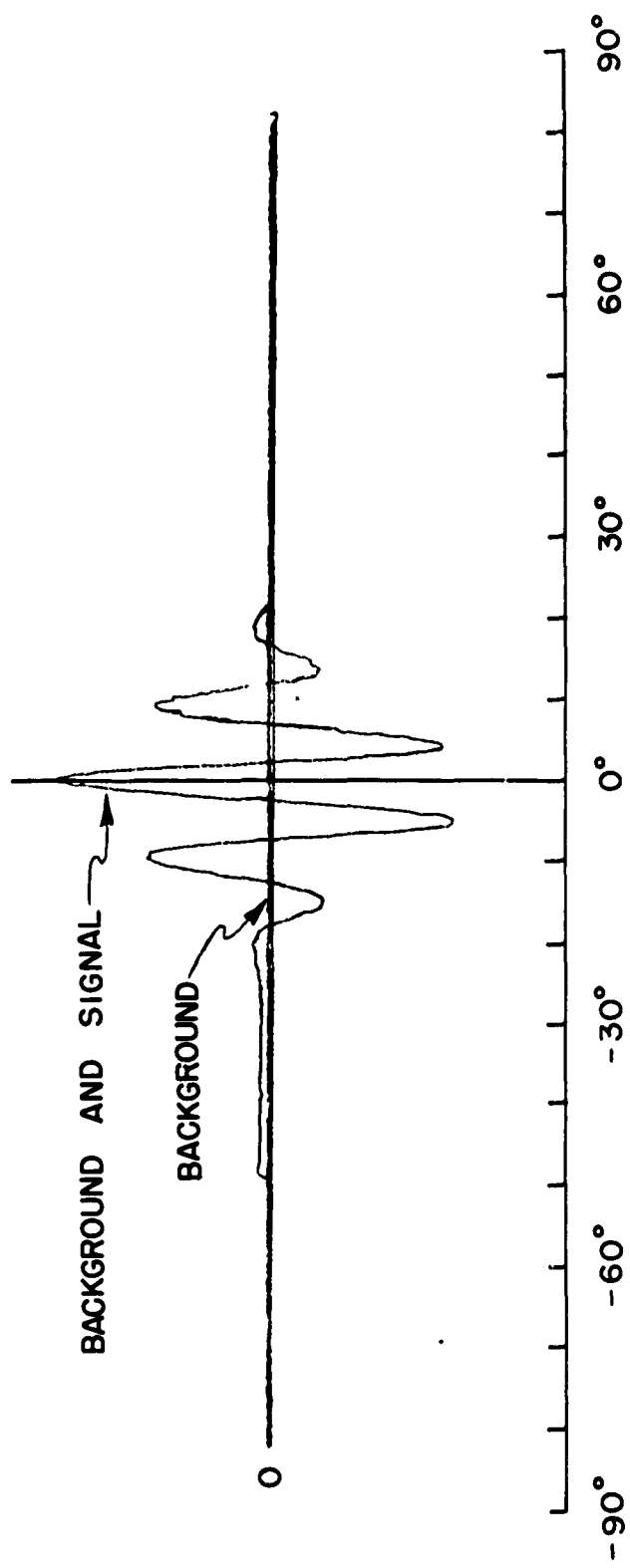

Fig. 4.9. Output of system using two 12-in. loudspeakers as directional receivers and a correlator; for background noise only, and for background noise plus a signal at 0°. Tuned-circuit spectrum with $Q = 4$.

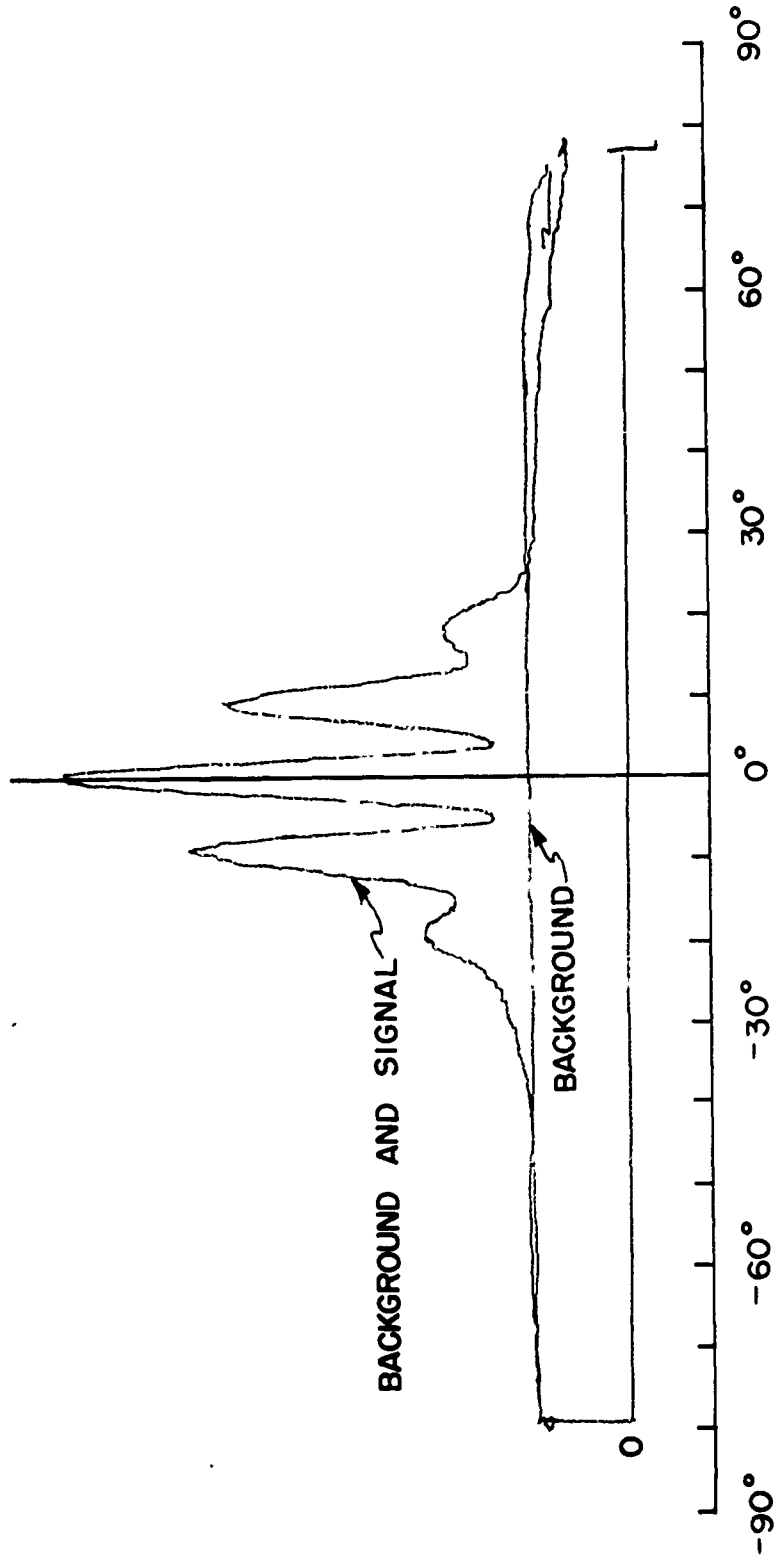

Fig. 4.10. Output of system using two 12-in. loudspeakers as directional receivers and sum-and-square-law detection; for background noise only, and for background noise plus a signal at 0°. Tuned-circuit spectrum with $Q = 4$.

kind, the operational advantages of the correlation detector may heavily outweigh the 3-db signal-to-noise disadvantage. These operational advantages are very forcefully presented by Ryle in the paper cited.

The response patterns of the two systems are very similar. If $K(\theta)$ is the receiving pattern of one speaker (relative voltage received as a function of angle), normalized so that $K(0) = 1$ ($K^2(\theta)$ is plotted in Fig. 4.8), the relative response of the correlation system to a signal is $K^2(0)\rho[(d/c)\sin\theta]$, where $\rho(\zeta)$ is the normalized autocorrelation function of the signal, while the relative response of the square-law detector system is $K^2(\theta)[1/2 + 1/2 \rho((d/c)\sin\theta)]$. Each of the patterns is of a distinctive form, possibly somewhat unusual in signal reception, but nonetheless useful. The beam-sharpness and resolving power of both are essentially the same.

All possible methods of processing the signals from a two-element array have by no means been exhausted, but on the basis of the examples studied here, it appears that there is little improvement in signal-to-noise ratio that can be effected by the use of correlation techniques in the processing of the received signals. The correlation systems, however, have a definite advantage in that they can be arranged so that they have no d-c response to background noise, greatly simplifying the task of searching closely the fluctuating part of the output of a system for the presence of signals, by allowing much higher gain recording or indicating instruments to be used at the output. Even in the case of an array of two directional receivers, when the correlator has a signal-to-noise ratio disadvantage of 3 db, this operational advantage of the correlation system may be so much more important as to dictate its use.

References

1. Schuck, O. H., C. K. Stedman, J. L. Hathaway, and A. N. Butz, Jr., "Bearing Deviation Indicator for Sonar," Trans. AIEE 66, 1285-1295 (1947).
2. Ryle, M., "A New Radio Interferometer and Its Application to the Observation of Weak Radio Stars," Proc. Roy. Soc. A. 211, 351-375 (March 6, 1952)

APPLICATION OF CORRELATION TECHNIQUES TO ARRAYS OF MORE THAN TWO ELEMENTS

In considering the possible application of correlation techniques to receiving arrays of more than two elements, one often faces the general problem of how to process many samples of a common signal in different (incoherent) noises so as to be best able to detect the presence of the signal. If the background noises in the different samples of signal plus noise are coherent to some degree, one has recourse to the various methods of "shading" which have been applied to linear arrays to achieve "superdirective" operation. However, it has been demonstrated in Chapter III that if omnidirectional receiving transducers are spaced more than a wavelength apart in an isotropic noise background, the received voltages will be essentially incoherent. We consider here only this case where the background noises may be assumed incoherent. The conventional processing of a set of m such samples of a common signal in different noises is simply to add, improving the power signal-to-noise ratio by a factor m , and detect. Many other possible methods of processing have come to mind after thinking about correlation techniques; of those which were selected for analysis here, none appears to provide a substantial improvement over simple addition and detection. These results are presented here to save others the trouble of repeating the investigations, and in the hope that they might stir someone's imagination to devise a really better signal processing system for this case (or to prove that there is none).

We shall assume that we have a linear array of m nondirectional receiving transducers spaced so widely that the voltage received by any two elements from an isotropic noise field are uncorrelated. We shall assume that a signal source is located broadside to the array at a great distance from it, so that the received signal is identical at each receiver. For purposes of comparison, we

first derive the signal-to-noise ratio which results when the samples of signal-in-noise are added and detected with a square-law* detector. We assume that the mean-square signal-to-noise ratio at each receiver, $(S/N)_{in}$, is the same, and that the amplitudes of the signals at each receiver are the same. Then, because the signals add linearly, while the incoherent noises add quadratically, there is, after addition, an improvement of the mean-square signal-to-noise ratio by a factor m . If this sum is then applied to a square-law detector, we have from Table 2.1 of TM 27 the output signal-to-noise ratio for a tuned-circuit spectrum of half-power half-width $\omega_p/2\pi$ and an RC averager,

$$2m^2\omega_p RC(S/N)_{in}^2.$$

This is the ratio of the square of the average output due to the signal to the mean-square of the fluctuation noise at the output of the detector. Not all of this average output can be counted as useful signal, however; there is a part of it which does not vanish as the array is turned away from the signal source and which cannot be distinguished from the d-c output due to the background noise. This point is illustrated by Figs. 5.1a, 5.1b, and 5.1c for arrays of 2, 3, and 4 elements. These show experimentally measured curves of the response of sum-and-square-law-detector systems to a random signal in the absence of a background noise. The numerical scale on each graph shows that the height of the signal above the maximum average output voltage is in each case only $(m-1)/m$ of the total output voltage due to the signal. That this should be true for all m can easily be demonstrated. Then, by these considerations (which we discussed in detail in the previous chapter), the output signal-to-noise ratio should correctly be taken as

$$(S/N)_{out} = 2(m-1)^2\omega_p RC(S/N)_{in}^2. \quad (5.1)$$

*Square-law for mathematical convenience. In Chap. IV of TM 27 it was shown that for small input signal-to-noise ratios there is little difference in output signal-to-noise ratio between linear and square-law detectors, the latter being very slightly superior.

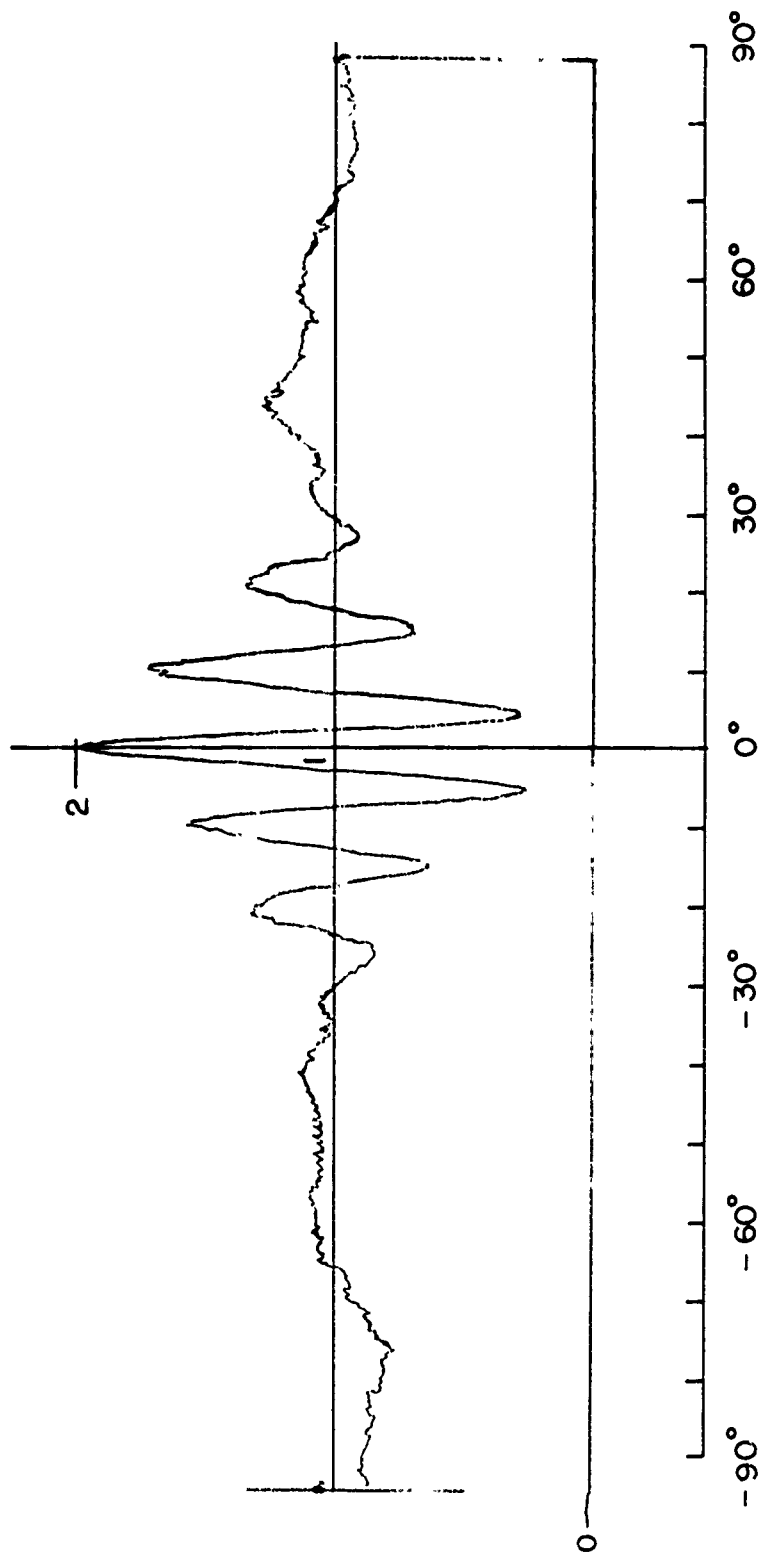

Fig. 5.1a. Response of two-element array with sum-and-square-law-detector system to signal source at 0° . Tuned-circuit spectrum with $Q = 2$.

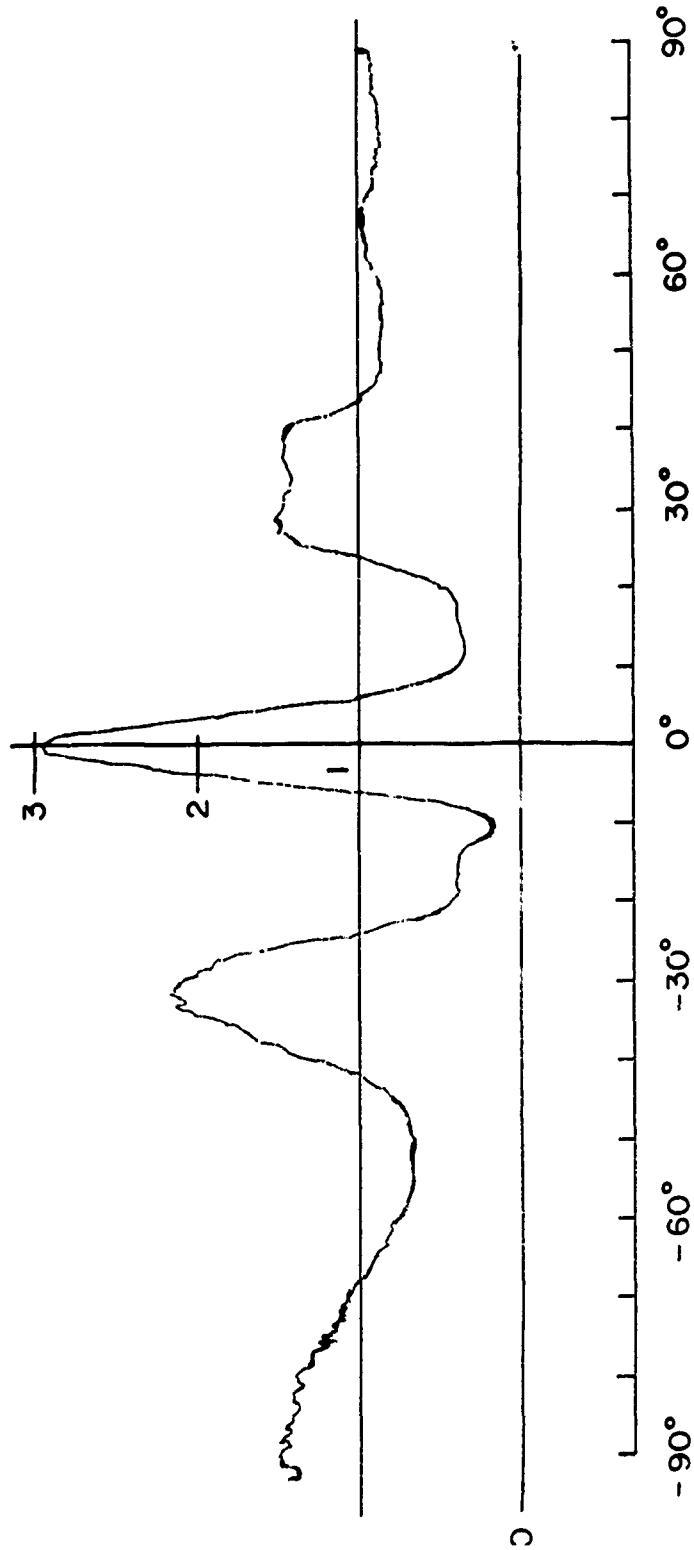

Fig. 5.1b. Response of three-element array with sum-and-square-law-detector system to signal source at 0° . Tuned-circuit spectrum with $Q = 2$.

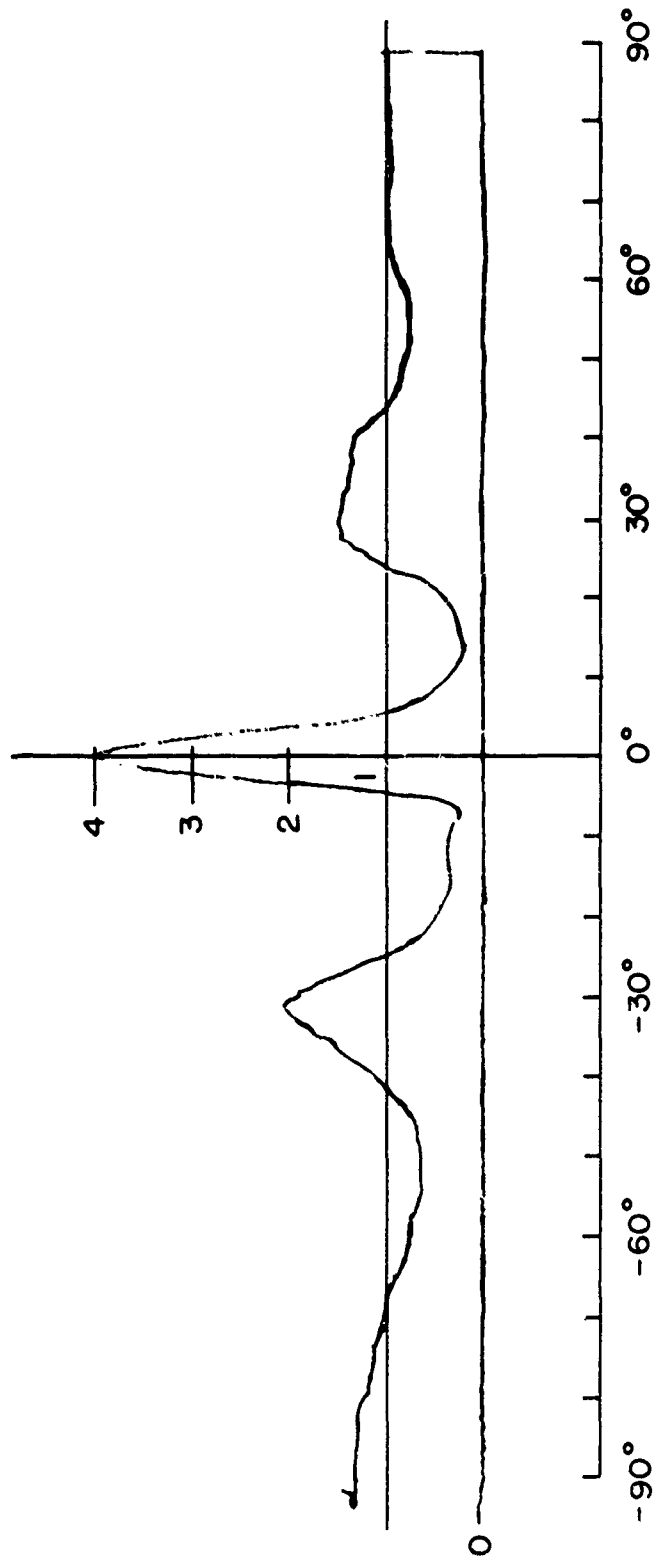

Fig. 5.1c. Response of four-element array with sum-and-square-law-detector system to signal source at 0°. Tuned-circuit spectrum with $Q = 2$.

With this formula available for comparison, we now turn our attention to other processing systems.

Many Correlators

A sufficient number of correlators can be used with an array to compute all the different cross-correlations by pairs between the received signals. For an array of m elements, this would require $m(m-1)/2$ correlators. Because the background noises at the different receivers are uncorrelated as we have assumed, the output fluctuation noises of all the correlators will also be uncorrelated if the signal is small, and the signal-to-noise ratio can be further improved by adding the outputs of all the correlators. If the mean-square input signal-to-noise ratio $(S/N)_{in}$ is small, the mean-square output signal-to-noise ratio of any correlator will be $4\omega_F RC(S/N)_{in}^2$ (Table 2.1 of TM 27), and after adding the correlator outputs (assuming that all signals and noises have the same amplitude), the system signal-to-noise ratio will be

$$(S/N)_{out} = 2m(m-1)\omega_F RC(S/N)_{in}^2$$

Relative output signal-to-noise ratios for this system and the sum-and-square-law-detector system are plotted in Fig. 5.2. There is a slight advantage in using this "many-correlators" system, but it is very slight and falls rapidly to nothing as the number of elements m increases.

On the other hand, the correlator system does have the greater advantage of no d-c output due to the background, allowing the use of higher gain recording and indicating instruments at the output of the system, as discussed in the previous chapter. It may occur to one that he might obtain this advantage by using one correlator with an array having an even number of elements by using as one input the sum of the received signals from half of the array, and as the other input the sum of the signals from the other half. The signal-to-noise ratio at each input to the

correlator would then be $(m/2)(S/N)_{in}$, and for the same spectrum and averager as above, the output signal-to-noise ratio would be

$$(S/N)_{out} = m^2 \omega_F RC (S/N)_{in}^2,$$

which, for large m , is inferior to that for the sum-and-square-law-detector system by 3 db.

The patterns or response to a signal source of the three systems discussed above are not greatly different. For a four-element linear array, of spacing d , and, for simplification, with $\tau = (d/2c)\sin\theta$, where c is the velocity of sound and θ the angular position of the signal source measured from broadside to the array, the average response to a signal (which would be $s(t)$ at the center of the array) would be, for the sum-and-law-detector system,

$$\begin{aligned} & \overline{[s(t-3\tau) + s(t-\tau) + s(t+\tau) + s(t+3\tau)]^2} \\ & = 4R(0) + 6R(2\tau) + 4R(4\tau) + 2R(6\tau), \end{aligned}$$

where $R(\tau)$ is the autocorrelation function of $s(t)$. If the six necessary correlators were used to compute all the different cross-correlations by pairs and their outputs added, the response would be

$$3R(2\tau) + 2R(4\tau) + R(6\tau).$$

These two patterns are of exactly the same form, except for the constant term which appears in the former. This parallels the situation for the two-element array discussed in the previous chapter, and it appears that it would be true for arrays of any number of elements. If the array were divided in half at the center, and the sums of the signals received by the two halves applied to a single correlator, the response would be

$$\begin{aligned} & \overline{[s(t-3\tau) + s(t-\tau) + s(t+\tau) + s(t+3\tau)]} \\ & = R(2\tau) + 2R(4\tau) + R(6\tau), \end{aligned}$$

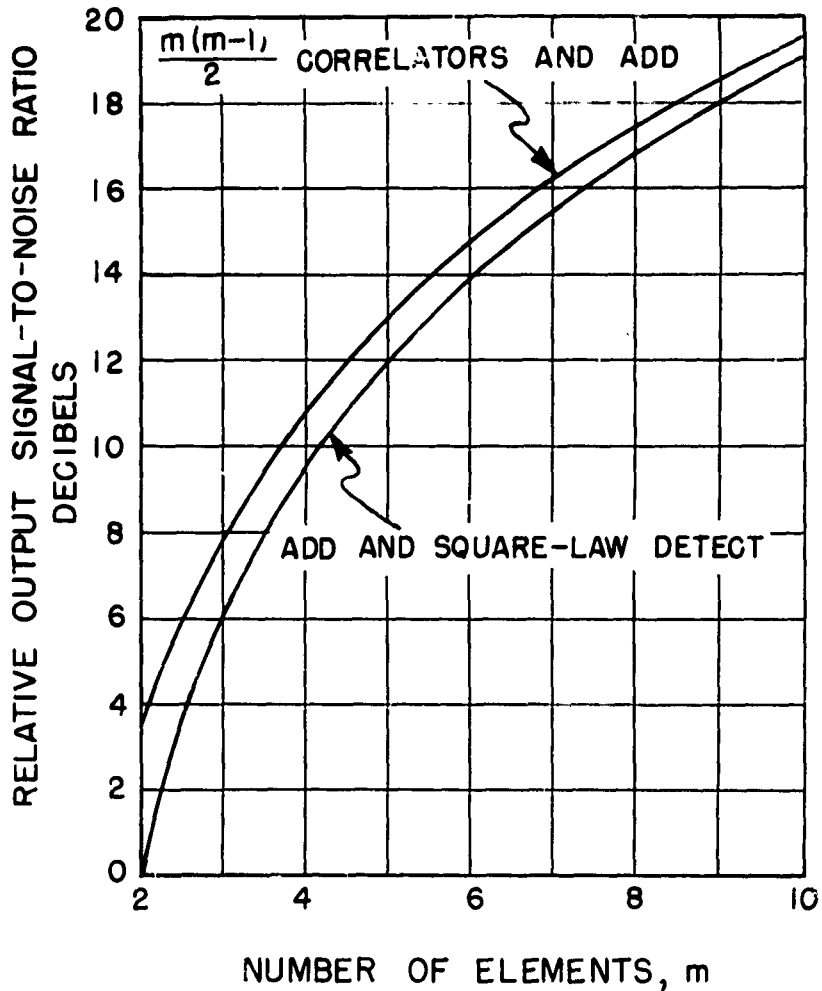

Fig. 5.2. Relative output signal-to-noise ratios for small input signal-to-noise ratios for an array of m wide-spaced elements with $m(m-1)/2$ correlators or sum-and-square-law-detector system as functions of the number of elements.

These three response patterns, normalized, are plotted in Figs. 5.3, 5.4, and 5.5 respectively, as functions of \mathcal{V} , for the tuned-circuit spectrum with $Q = 2$. The three patterns are very similar. It thus appears that no significant improvement in the signal-to-noise ratio can be made by systems such as those discussed above, while the response patterns are nearly identical, also.

m-Fold Product

In searching for a better method of determining the presence of a common signal in many samples of the signal in incoherent background noises, such as one might obtain from a wide-spaced linear array, we have tried to devise a method of performing a multiple correlation. What appeared to be a possible way of doing this was to form the instantaneous m-fold product of the m sample of signal in noise and average. With the background noises all uncorrelated, this system would have no d-c output due to the background. It would only operate for an even number of samples of signal and noise; if the signal were symmetrically distributed and of zero average value, the average value of any odd power would be zero. We can estimate the output signal-to-noise ratio easily if we assume that the output fluctuation noise is the same in the presence of a small signal as in its absence.

Assume that we have an even number, m, of samples of signal in noise, $[n_1(t) + s(t)]$, $[n_2(t) + s(t)]$, $[n_m(t) + s(t)]$, and that the noises and the signal are all incoherent, i.e., $\overline{n_i(t)n_j(t)} = 0$ and $\overline{n_i(t)s(t)} = 0$, for all i, j. The average value of the m-fold product of these is

$$\begin{aligned} \overline{F(t)} &= \overline{[n_1(t) + s(t)] [n_2(t) + s(t)] \dots [n_m(t) + s(t)]} \\ &= s^m(t). \end{aligned}$$

For a gaussianly distributed signal of mean-square $\overline{s^2(t)} = S$,

$$\overline{F(t)} = \frac{m}{2^{m/2}(m/2)!} S^{m/2},$$

(Eq. (1.3) of TM 27). In the absence of the signal, the output of the averager is

$$F(t) = \int_0^{\infty} g(t') n_1(t-t') n_2(t-t') \dots n_m(t-t') dt',$$

and its mean-square is

$$\begin{aligned} \overline{F^2(t)} &= \int_0^{\infty} \int_0^{\infty} g(t') g(t'') \overline{n_1(t-t') n_2(t-t') \dots n_m(t-t')} \\ &\quad \cdot \overline{n_1(t-t'') n_2(t-t'') \dots n_m(t-t'')} dt' dt'' \\ &= \int_0^{\infty} \int_0^{\infty} g(t') g(t'') R_1(t''-t') R_2(t''-t') \dots R_m(t''-t') \\ &\quad dt' dt'', \end{aligned}$$

$g(t)$ being the weighting function of the averager and $R_1(t''-t')$ the autocorrelation function of $n_1(t)$, etc. If all the noises have the same amplitude and spectrum all the R 's are equal, and

$$\begin{aligned} \overline{F^2(t)} &= \int_0^{\infty} \int_0^{\infty} g(t') g(t'') R^m(t''-t') dt' dt'' \\ &= \int_{-\infty}^{\infty} w(\xi) R^m(\xi) d\xi, \end{aligned}$$

where $w(\xi)$ is the transformed weighting function of the averager (Chap. II, TM 27). Writing

$$R(\xi) = N\rho(\xi),$$

where N is the mean-square and $\rho(\xi)$ the normalized autocorrelation function of the noises,

$$\overline{F^2(t)} = N^m \int_{-\infty}^{\infty} w(\xi) \rho^m(\xi) d\xi.$$

The mean-square output signal-to-noise ratio for small input signal-to-noise ratios is then

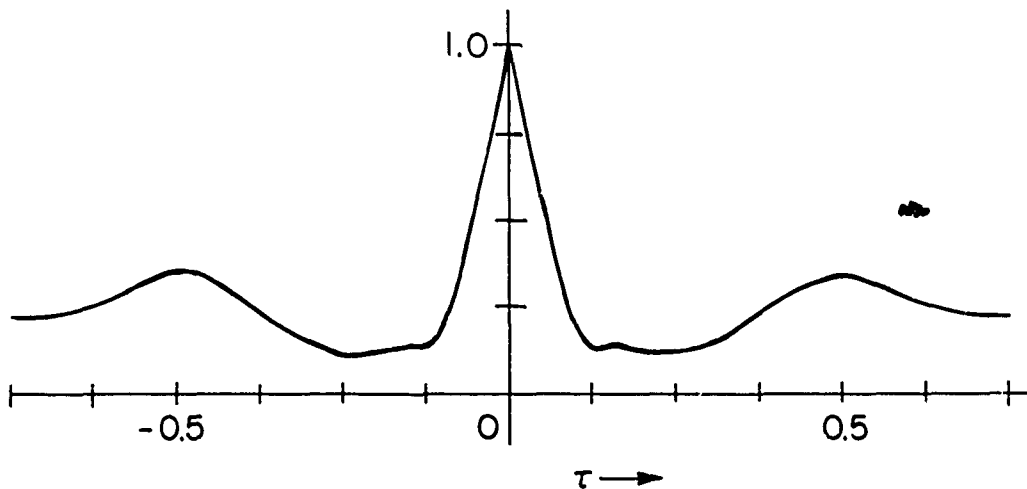

Fig. 5.3. Response of a four-element linear array with spacing d between the elements to a signal source at 0° using a sum-and-square-law-detector system. Tuned-circuit spectrum with $Q = 2$.

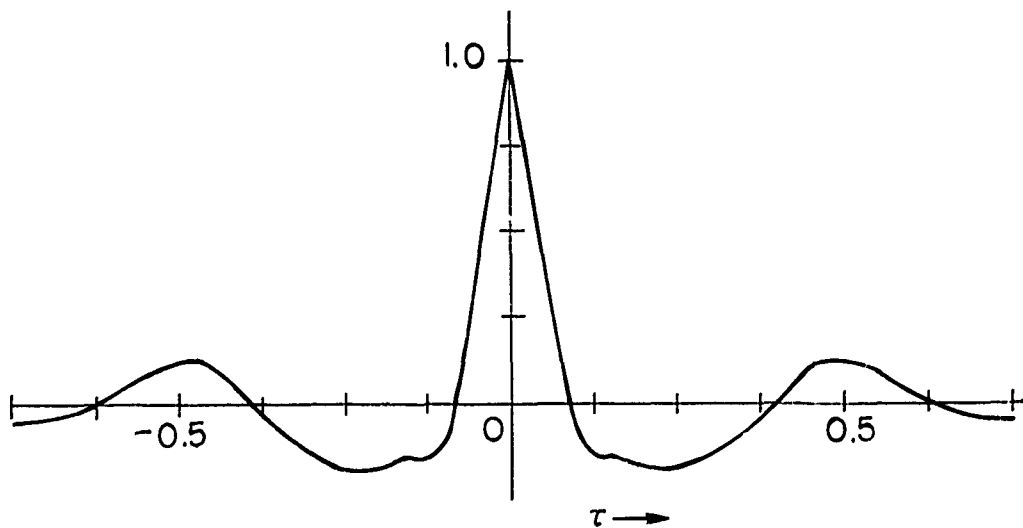

Fig. 5.4. Response of a four-element linear array with spacing d between the elements to a signal source at 0° using 6 correlators. Tuned-circuit spectrum with $Q = 2$.

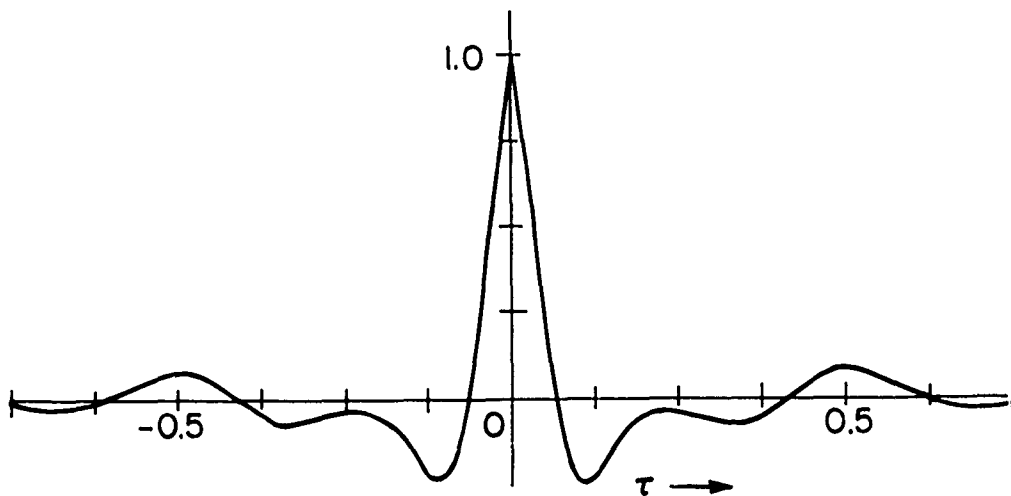

Fig. 5.5. Response of a four-element linear array with spacing d between the elements to a signal source at 0° using a single correlator to correlate the signals received by the two halves of the array. Tuned-circuit spectrum with $Q = 2$

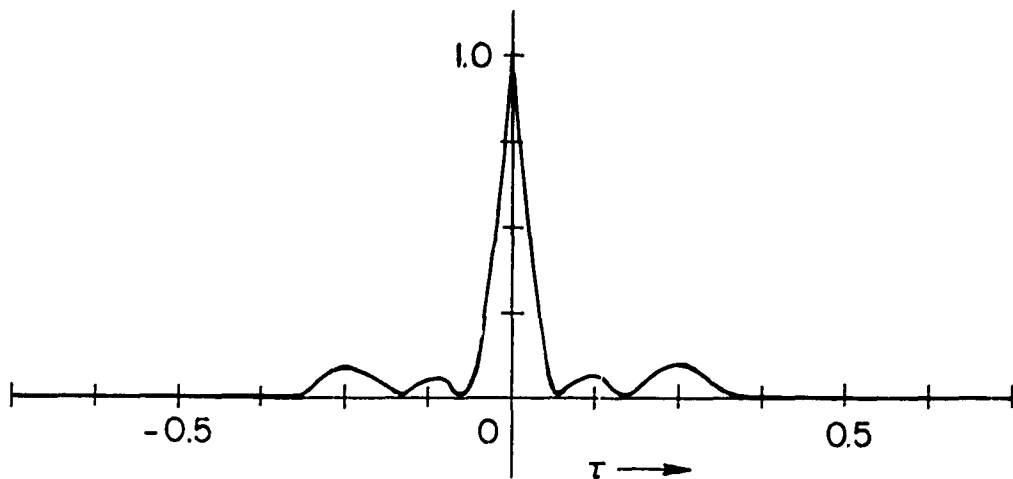

Fig. 5.6. Response of a four-element linear array with spacing d between the elements to a signal source at 0° using a 4-fold-product-averager. Tuned-circuit spectrum with $Q = 2$.

$$(S/N)_{out} = \frac{\overline{F(t)^2}}{F^2(t)} = \frac{m!^2}{2^m (m/2)!^2} \frac{(S/N)_{in}^m}{\int_{-\infty}^{\infty} w(\xi) \rho^m(\xi) d\xi} .$$

The integral in the denominator is simply J of Eq. (4.13) of TM 27 (with $m = 2l$). For a tuned-circuit spectrum and RC averager with $RC \gg 1/\omega_p$, we found there that

$$J \cong \frac{m!}{2^m (m/2)!^2 m \omega_p RC} .$$

Then subject to the above restrictions (and for a gaussian signal), the small-signal output signal-to-noise ratio is

$$(S/N)_{out} = m! m \omega_p RC (S/N)_{in}^m .$$

We compare this result also with Eq. (5.1) for the sum-and-square-law-detector system. In this case the output signal-to-noise ratio is proportional to the m^{th} power of the input signal-to-noise ratio; for large m and small input signal-to-noise ratios this is signal suppression of a very advanced degree! A more useful comparison can be made in terms of the minimum detectable signal-to-noise ratio. Suppose that $(S/N)_{out}^{\dagger}$ is the minimum detectable output signal-to-noise ratio; then the minimum detectable input signal-to-noise ratio is, for the m -fold product system,

$$(S/N)_{in}^{\dagger} = \sqrt[m]{\frac{(S/N)_{out}^{\dagger}}{m! m \omega_p RC}}$$

and, for the square-law detector system (from Eq. (5.1)),

$$(S/N)_{in}^{\dagger} = \sqrt{\frac{(S/N)_{out}^{\dagger}}{2(m-1)^2 \omega_p RC}} .$$

Minimum detectable input signal-to-noise ratios for these two systems are compared in Table 5.1 below for $(S/N)_{out}^{\dagger} = 1$, and $\omega_p RC = 1,000$ and $10,000$, values which are not difficult to

Table 5.1

Minimum Detectable Input Signal-to-Noise Ratios for Square-Law Detector and m-Fold Product System for Various m; Tuned-Circuit Spectrum and RC Averager.

m =	2	4	6	8	10
$\omega_F RC = 1,000$					
Square-Law	-16.5 db	-21.3 db	-23.5 db	-25.0 db	-26.0 db
m-Fold Prod.	-18.0	-12.5	-11.0	-10.7	- 8.6
$\omega_F RC = 10,000$					
Square-Law	-21.5	-26.3	-28.5	-30.0	-31.0
m-Fold Prod.	-23.0	-13.4	-12.7	-11.9	- 9.6

achieve in an audiofrequency system. The adverse effect of signal suppression is clearly demonstrated here: the minimum detectable signal-to-noise ratio for the m-fold product system actually increases as the number of elements is increased. The pattern of a four-fold product system using a four-element linear array is

$$R^2(2\tau) + R^2(4\tau) + R(2\tau)R(6\tau) ,$$

as may be seen from Appendix I of TM27, where d is the spacing of the elements, and $\tau = (d/2c)\sin \theta$. This pattern, normalized, is plotted in Fig. 5.6 to the same scale as those of Figs. 5.3-5.5. This pattern is much narrower than the previous ones, and has much smaller "minor lobes," because of its dependence on the products and squares of correlation functions, rather than linear combinations. Because of the difficulty of constructing a multiple-product multiplier, and in view of the discouraging theoretical predictions with regard to signal-to-noise ratio, no experimental investigation of this system has been attempted.

Multiple-Polarity-Coincidence Correlation

A suggestion has been made that the principle of polarity-coincidence correlation (Chap. V, TM 27) be extended to a simultaneous testing of more than two samples of signal in noise.¹ A comparison of the performance of such a system with that of a sum-and-square-law-detector system has been made both theoretically and experimentally. We assume that a multiple-polarity-coincidence correlator is a device having m inputs and one output, the output before averaging being 1 v. whenever the polarities of all inputs are the same, and zero at all other times. This operation is one which can readily be achieved electronically by a combination of clipping, adding, rectifying, and center-clipping circuits. We first compute the signal output for the limiting case of small input signal-to-noise ratio, then estimate the no-signal output noise, and therefrom derive the small-signal output signal-to-noise ratio.

When all the inputs are symmetrically distributed random functions of zero average value, the probability that the i^{th} input, $n_i(t)$, is positive is

$$\int_0^{\infty} P_n(n) dn = 1/2, \quad (5.1)$$

where $P_n(n)$ is the probability density of $n(t)$ (See Chap. I, TM 27). If all m inputs are incoherent, the probability that all m inputs are positive is

$$(1/2)^m.$$

The probability that all m inputs are negative is the same. Then, by the above definition of the output of this system, the average output when all inputs are incoherent is

$$2(1/2)^m = \frac{1}{2^{m-1}}. \quad (5.2)$$

This average output in the absence of a signal is dependent only on the presence of uncorrelated noises at each input and not on

the amplitude of the background noise at a particular moment. It therefore could be balanced out once and for all by a single setting of a battery voltage. Now, if a common signal is present at each input in addition to the noise, the probability that, at an instant when $s(t)$ has the positive value s_0 , the i^{th} input $n_i(t) + s(t)$ is positive is

$$\int_{-s_0}^{\infty} P_n(n) dn,$$

and the probability that all m inputs are positive is

$$\left[\int_{-s_0}^{\infty} P_n(n) dn \right]^m.$$

The probability that all m inputs are positive when $s(t)$ is positive is found by averaging over all positive values of $s(t)$:

$$2 \int_0^{\infty} P_s(s) \left[\int_{-s}^{\infty} P_n(n) dn \right]^m ds,$$

$P_s(s)$ being the probability density of $s(t)$, which is also assumed symmetrically distributed and of zero average value. The probability that all m inputs are negative when $s(t)$ is positive is

$$2 \int_0^{\infty} P_s(s) \left[\int_{-\infty}^{-s} P_n(n) dn \right]^m ds.$$

The total probability that all m inputs have the same polarity when $s(t)$ is positive is then

$$2 \int_0^{\infty} P_s(s) \left\{ \left[\int_{-s}^{\infty} P_n(n) dn \right]^m + \left[\int_{-\infty}^{-s} P_n(n) dn \right]^m \right\} ds.$$

The probability that all m inputs will have the same polarity when $s(t)$ is negative will be the same, by virtue of the assumed symmetry of the distributions. The average output of the system in the presence of a signal is then the same as the above expression,

which may be written (making use of Eq. (5.1))

$$\frac{1}{2^{m-1}} \int_0^{\infty} P_s(s) \left\{ \left[1 + 2 \int_0^s P_n(n) dn \right]^m + \left[1 - 2 \int_0^s P_n(n) dn \right]^m \right\} ds$$

and the output signal voltage is

$$\frac{1}{2^{m-1}} \int_0^{\infty} P_s(s) \left\{ \left[1 + 2 \int_0^s P_n(n) dn \right]^m + \left[1 - 2 \int_0^s P_n(n) dn \right]^m \right\} ds - \frac{1}{2^{m-1}}$$

Now, if the noise is gaussianly distributed and has the mean-square N ,

$$\int_0^s P_n(n) dn = 1/2 \operatorname{erf} \left(\frac{s}{\sqrt{2N}} \right),$$

and the output signal is

$$\begin{aligned} & \frac{1}{2^{m-1}} \int_0^{\infty} P_s(s) \left\{ \left[1 + \operatorname{erf} \left(\frac{s}{\sqrt{2N}} \right) \right]^m + \left[1 - \operatorname{erf} \left(\frac{s}{\sqrt{2N}} \right) \right]^m \right\} ds - \frac{1}{2^{m-1}} \\ &= \frac{1}{2^{m-1}} \int_0^{\infty} P_s(s) \left[2 + m(m-1) \operatorname{erf}^2 \left(\frac{s}{\sqrt{2N}} \right) \right. \\ & \quad \left. + \frac{m(m-1)(m-2)(m-3)}{12} \operatorname{erf}^4 \left(\frac{s}{\sqrt{2N}} \right) + \dots \right] ds - \frac{1}{2^{m-1}} \\ &= \frac{1}{2^{m-1}} \int_0^{\infty} P_s(s) \left[m(m-1) \operatorname{erf}^2 \left(\frac{s}{\sqrt{2N}} \right) + \frac{m(m-1)(m-2)(m-3)}{12} \operatorname{erf}^4 \left(\frac{s}{\sqrt{2N}} \right) \right. \\ & \quad \left. + \dots \right] ds. \end{aligned}$$

Using the series expansion for the error function,

$$\operatorname{erf} x = \frac{2}{\sqrt{\pi}} \left[x - \frac{x^3}{3 \cdot 1!} + \frac{x^5}{5 \cdot 2!} - \frac{x^7}{7 \cdot 3!} + \dots \right],$$

the output signal can be written

$$\frac{1}{2^{m-1}} \int_0^{\infty} P_s(s) \left\{ \frac{4m(m-1)}{\pi} \left[\frac{s^2}{2N} - \frac{2}{3} \frac{s^4}{4N^2} + \frac{1}{9} \frac{s^6}{8N^3} + \dots \right] \right. \\ \left. + \frac{4m(m-1)(m-2)(m-3)}{3! \cdot 2} \left[\frac{s^4}{4N^2} - \frac{4}{3} \frac{s^6}{8N^3} + \dots \right] \right\} ds.$$

We then substitute for $P_s(s)$ the gaussian distribution for the function $s(t)$ whose mean-square is S . Now the higher powers of s in the series above will contribute terms of higher order in (S/N) ; subject to the assumption that $(S/N)_{in}$ is small, we may neglect these terms. For small input signal-to-noise ratios, then, the output signal will be

$$\frac{m(m-1)}{2^{m-1} \pi N} \int_{-\infty}^{\infty} P_s(s) s^2 ds = \frac{m(m-1)}{2^{m-1} \pi} (S/N)_{in}. \quad (5.3)$$

Here $(S/N)_{in}$ is, as usual, the mean-square input signal-to-noise ratio.

We assume that the output fluctuation noise in the presence of a small input signal is not different from that in the absence of a signal. Now if $f(t)$ is the input to a filter whose weighting function is $g(t)$, the output of the filter is

$$F(t) = \int_0^{\infty} g(t') f(t-t') dt',$$

and the mean square of the output is

$$\overline{F^2(t)} = \int_0^{\infty} g(t') f(t-t') dt' \int_0^{\infty} g(t'') f(t-t'') dt'' \\ = \int_0^{\infty} \int_0^{\infty} g(t') g(t'') \overline{f(t-t') f(t-t'')} dt' dt'' \\ = \int_{-\infty}^{\infty} w(\xi) R(\xi) d\xi, \quad (5.4)$$

where $R(\xi)$ is the autocorrelation function of $f(t)$ and $w(\xi)$ is the transformed weighting function of the filter (See Chap. II, TM 27). To evaluate the mean-square output noise we need to find the autocorrelation function of the output before averaging, that is, of the wave which is $\pm 1 v$, when all the inputs have the same polarity and zero elsewhere. Now if $P_m^i(u, v, \mathcal{Z})$ is the second probability distribution for this wave, u and v being two possible values separated by the interval \mathcal{Z} , its autocorrelation function can easily be found as

$$R(\mathcal{Z}) = \int_{-\infty}^{\infty} \int_{-\infty}^{\infty} u v P_m^i(u, v, \mathcal{Z}) du dv, \quad (5.5)$$

Now assume that a random voltage wave is symmetrically distributed and has zero average value, and is strongly clipped to the values $\pm 1 v$. The second probability density $P_{cl}^i(x, y, \mathcal{Z})$ for the clipped wave is different from zero only at four points; it is

$$\left. \begin{aligned} P_{cl}^i(1, 1, \mathcal{Z}) &= \int_0^{\infty} \int_0^{\infty} P(x, y, \mathcal{Z}) dx dy \\ P_{cl}^i(1, -1, \mathcal{Z}) &= \int_{-\infty}^0 \int_0^{\infty} P(x, y, \mathcal{Z}) dx dy \\ P_{cl}^i(-1, 1, \mathcal{Z}) &= \int_0^{\infty} \int_{-\infty}^0 P(x, y, \mathcal{Z}) dx dy \\ P_{cl}^i(-1, -1, \mathcal{Z}) &= \int_{-\infty}^0 \int_{-\infty}^0 P(x, y, \mathcal{Z}) dx dy, \end{aligned} \right\} \quad (5.6)$$

where $P(x, y, \mathcal{Z})$ is the second probability density for the wave before clipping, x and y being two possible values of this wave separated by an interval \mathcal{Z} . The sum of two such strongly clipped waves takes on only the values 2, 0, and -2, and there are nine

points at which its second probability density P_2 is different from zero, $(2,2)$, $(2,0)$, $(2,-2)$, $(0,2)$, etc. The sum of m such strongly clipped waves takes on the values $m, m-2, m-4, \dots, -m$, and for large m there are a good many points where its second probability density P_m is different from zero. If we assume that the m -fold sum is rectified and center-clipped so that the resultant wave is 1 v. only when the sum is m or $-m$, we need to know only the values of P_m for the sum at the points (m,m) , $(m,-m)$, $(-m,m)$ and $(-m,-m)$, for everywhere else either the factor u or v in the integrand of Eq. (5.5) will be zero. Let $P_m(m,m,\tau)$ be the probability that all m input waves have the value 1 at some time, and the value 1 a time τ later. Since all input waves are assumed independent,

$$P_m(m,m,\tau) = [P_{cl}(1,1,\tau)]^m,$$

and using a prime to denote the further operations of rectifying and center-clipping, the corresponding value of the second probability density for the output wave is

$$P_m'(1,1,\tau) = [P_{cl}(1,1,\tau)]^m.$$

Because of the symmetry of the distributions,

$$P_m'(-1,-1,\tau) = [P_{cl}(-1,-1,\tau)]^m = [P_{cl}(1,1,\tau)]^m.$$

Also,

$$P_m'(1,-1,\tau) = P_m'(-1,1,\tau) = [P_{cl}(1,-1,\tau)]^m.$$

The autocorrelation function is then computed from Eq. (5.4) after converting the integral to a sum over the four discrete points at which P_m' is different from zero:

$$\begin{aligned} R(\tau) &= |1| \cdot |1| P_m'(1,1,\tau) + |-1| \cdot |-1| P_m'(-1,-1,\tau) \\ &+ |1| \cdot |-1| P_m'(1,-1,\tau) + |-1| \cdot |1| P_m'(-1,1,\tau) \\ &= 2[P_{cl}(1,1,\tau)]^m + 2[P_{cl}(1,-1,\tau)]^m. \end{aligned}$$

Now $P_{ci}(1,1,\mathcal{Z})$, defined in Eqs. (5.6), is of the same functional form as p , evaluated in Chapter V, TM 27, which was there the probability that two incoherent inputs to a polarity coincidence correlator would be positive at the same time. We found there, for gaussianly distributed random input functions,

$$p = \frac{1}{4} + \frac{1}{2\pi} \sin^{-1} \rho(\mathcal{Z}) = \frac{1}{2} - \frac{1}{2\pi} \cos^{-1} \rho(\mathcal{Z}),$$

so

$$P_{c1}(1,1,\mathcal{Z}) = \frac{1}{2} - \frac{1}{2\pi} \cos^{-1} \rho(\mathcal{Z}),$$

where $\rho(\mathcal{Z})$ is the normalized autocorrelation function of any of the noises before clipping. By changing the limits of integration and carrying through the same procedure as in TM 27, we find that

$$P_{c1}(1,-1,\mathcal{Z}) = \frac{1}{2\pi} \cos^{-1} \rho(\mathcal{Z}).$$

The autocorrelation function of the output of our multiple polarity coincidence correlator is then

$$\begin{aligned} R(\mathcal{Z}) &= 2\left[\frac{1}{2} - \frac{1}{2\pi} \cos^{-1} \rho(\mathcal{Z})\right]^m + 2\left[\frac{1}{2\pi} \cos^{-1} \rho(\mathcal{Z})\right]^m \\ &= \frac{1}{2^{m-1}} \left\{ \sum_{r=0}^m \frac{(-1)^r m!}{(m-r)! r!} \left[\frac{1}{\pi} \cos^{-1} \rho(\mathcal{Z})\right]^r \right. \\ &\quad \left. + \left[\frac{1}{\pi} \cos^{-1} \rho(\mathcal{Z})\right]^m \right\}. \end{aligned}$$

Substitution of this expression in Eq. (5.4) leads to evaluation of the mean-square of the output of the filter, but not painlessly. Examination of the above formula for $R(\mathcal{Z})$ shows that $R(\text{co}) = 1/4^{m-1}$; this represents the square of the average output of the filter and must be subtracted from the integrand if one is to evaluate only the fluctuating part of the output. The mean-square of the noise output can then be written

$$N_{\text{out}} = \frac{1}{2^{m-1}} \int_{-\infty}^{\infty} w(\xi) \left\{ \sum_{r=0}^m \frac{(-1)^r m!}{(m-r)! r!} \left[\frac{1}{\pi} \cos^{-1} \rho(\xi) \right] + \left[\frac{1}{\pi} \cos^{-1} \rho(\xi) \right]^m - \frac{1}{2^{m-1}} \right\} d\xi.$$

The usual simplification of assuming that the input bandwidth is so wide compared to the band-pass of the averager that $w(\xi)$ can be replaced by $w(0)$ is effected; for an RC averager we then have

$$N_{\text{out}} = \frac{1}{2^m RC} \int_{-\infty}^{\infty} \left\{ \sum_{r=0}^m \frac{(-1)^r m!}{(m-r)! r!} \left[\frac{1}{\pi} \cos^{-1} \rho(\xi) \right]^r + \left[\frac{1}{\pi} \cos^{-1} \rho(\xi) \right]^m - \frac{1}{2^{m-1}} \right\} d\xi.$$

Because of the difficulty of carrying out this integration directly, the integral has been approximately evaluated for only one case, by plotting the integrand and integrating graphically. The result, for $m = 4$ and a tuned-circuit input spectrum with $Q = 2$, was

$$N_{\text{out}} = \frac{0.132}{\omega_F RC} ;$$

where ω_F is the angular half-bandwidth of the input spectrum. The output signal voltage (Eq. (5.3)) is, for $m = 4$,

$$\frac{12}{8\pi} (S/N)_{\text{in}},$$

so the mean-square output signal-to-noise ratio is

$$(S/N)_{\text{out}} = 17.2 \omega_F RC (S/N)_{\text{in}}^2 ,$$

a result which is almost certainly valid only for $Q = 2$. The corresponding quantity for the sum-and-square-law-detector system (Eq. (5.1)) is

$$(S/N)_{out} = 18.0 \omega_p RC (S/N)_{in}^2$$

It thus appears, on the basis of this admittedly approximate evaluation, that there is little difference in the small-signal output signal-to-noise ratio between the two systems.

A test of a very similar system has been made with the experimental apparatus described in Chapter II. A linear array of four microphones with two-wavelength spacing at the center frequency was connected to four clipper amplifier circuits of the type shown in Fig. 5.7, which were in turn connected to the coincidence averager shown in Fig. 5.8. The operation of this circuit is a little different from that of the ideal multiple polarity coincidence correlator described above; the center clipping operation was omitted for simplicity. No significant change in the operation at very small signals is expected, however, since, except for a different constant term, the output autocorrelation function for this type of circuit is the same as for the ideal circuit above, and the output signal for small input signal-to-noise ratios is only different by terms of the second order. Signal-to-noise ratios measured for a tuned-circuit input spectrum with $Q = 4$ showed an advantage of 2 db for the sum-and-square-law-detector system over the multiple polarity coincidence system. From these sparse data of limited accuracy, we should only conclude that there is little difference in the small-signal output signal-to-noise ratio between the two systems compared above. It is hoped that a method of simplifying the necessary computations will be devised in order to extend the comparison to larger numbers of input signals. Graphs of the output of the sum-and-square-law-detector system and of the multiple-polarity-coincidence system used with a four-element array with two-wavelength spacing are shown in Figs. 5.9 and 5.10, respectively. These curves were plotted for background noise only, and for background noise plus a signal at 0 degrees for the tuned-circuit spectrum with $Q = 4$. There is an essential

difference between the two patterns; the response of the multiple-polarity-coincidence system does fall to zero as the signal is moved in angle away from the principal axis. This, in addition to the lack of dependence of the amplitude of the average output of this system upon the amplitude of the background noise, makes possible the use at the output of high-gain recording or indicating instruments (which, with the square-law-detector system, might be driven off-scale by small changes in the background level). For this reason, the multiple-polarity-coincidence correlator might be the most useful system for the detection, with a wide-spaced array, of small random signals in a noise background.

References

1. Melton, B. S., and P. R. Karr, "A Proposal for the Determination of Coherence in a Signal Field," Paper 44, I.R.E. National Convention, New York (March, 1952).

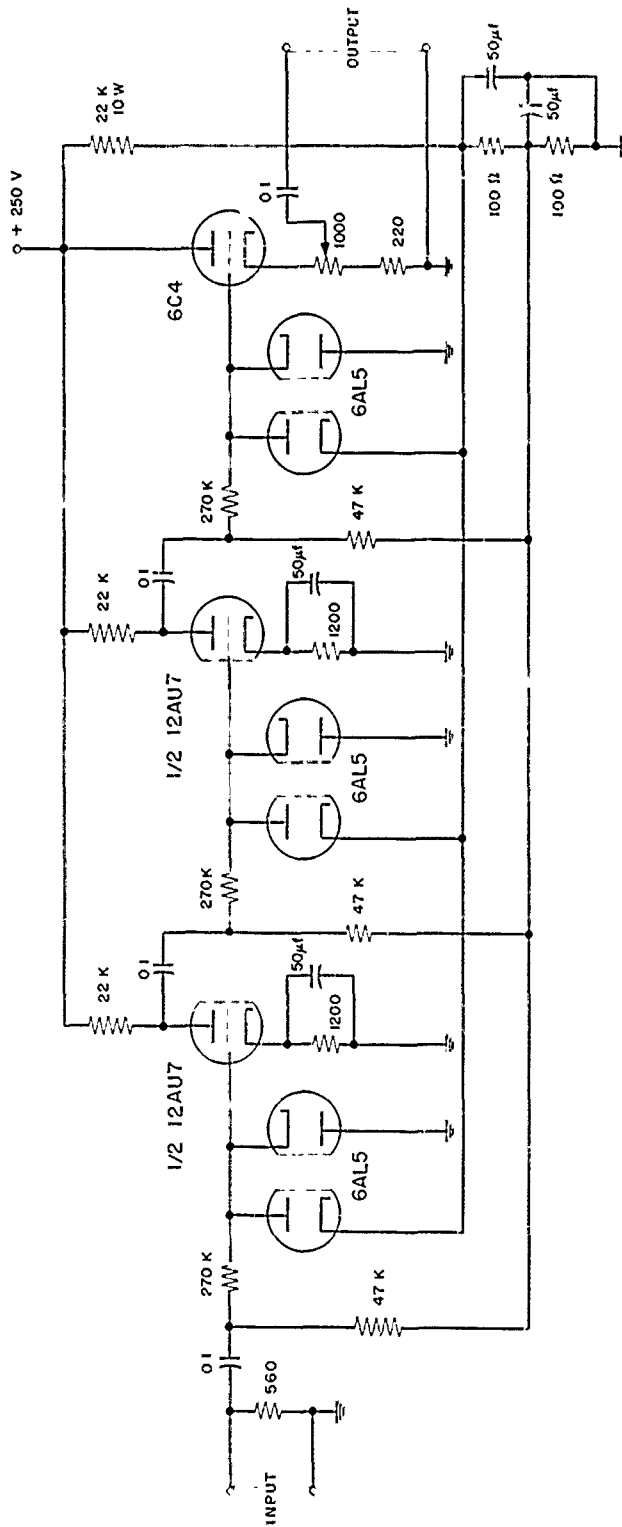

Fig. 5.7. Schematic diagram of clipper-amplifier circuit, four of which were used to construct a multiple-polarity coincidence correlator.

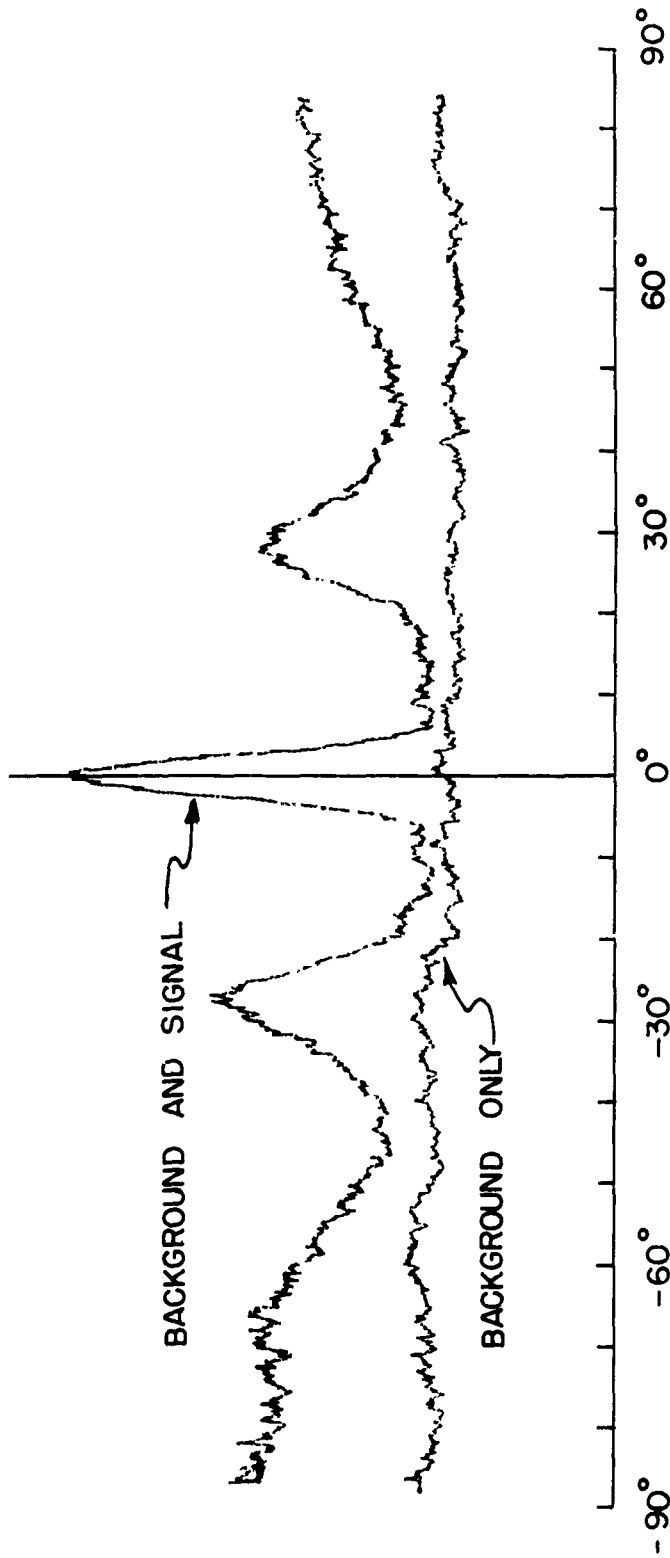

Fig. 5.9. Output of sum-and-square-law-detector system used with a four-element array for background noise only and for background noise plus a signal at 0°. Tuned-circuit spectrum with $Q = 4$.

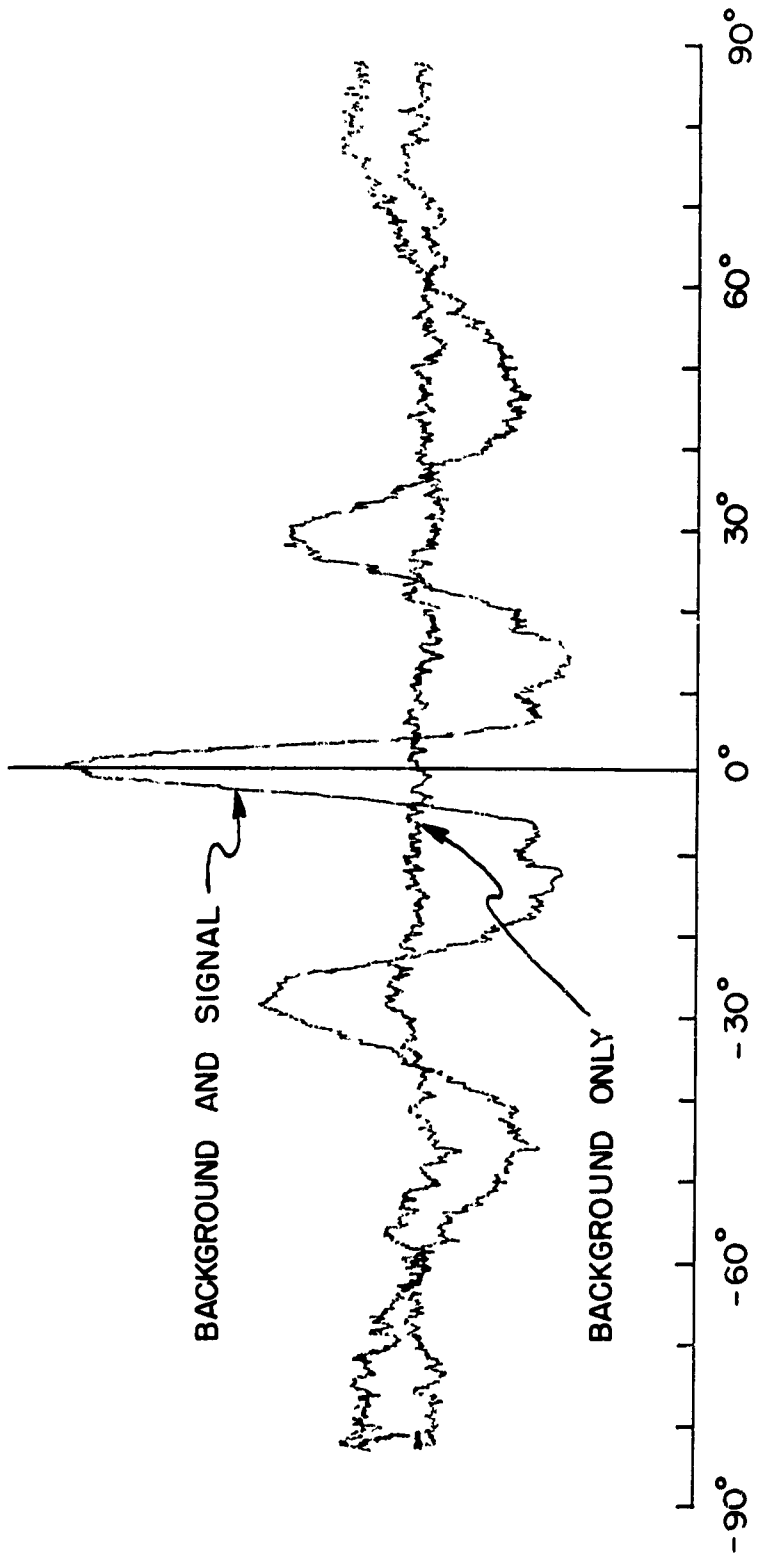

Fig. 5.10. Output of multiple-polarity-coincidence correlator used with a four-element array for background noise only, and for background noise plus a signal at 0°. Tuned-circuit spectrum with $Q = 4$.

VI

POST-DETECTION CORRELATION SYSTEMS

It has been suggested that a correlation method might be used to determine the presence of a signal at the output of a detector if, because of some previous operation, the envelope of the signal had been given a known time-functional form. For example, if it were possible to turn the signal source on and off periodically, there would appear in addition to noise at the output of the receiver detector rectangular voltage waves whose presence might be detected with great sensitivity by cross-correlating the output of the detector with a standard rectangular wave of the same frequency and phase. Although it is almost never possible to turn the signal source on and off in this way at will, it is possible to operate on the receiving system to achieve the same effect. For example, imagine a directional receiving transducer which is split electrically into two halves, in such a way that the sum of the signals received by the two halves corresponds to a receiving beam pattern which has maximum sensitivity on the principal axis of the transducer, while the difference of these signals has a null of sensitivity on the axis. It is quite possible that the background noise power received with the two different connections will be the same. Then, if a switch periodically connects first the sum and then the difference of these signals to the input of a receiver, and if there is a signal source on the principal axis, there will appear at the output of the detector a rectangular voltage whose amplitude is dependent upon the strength of the signal and whose amplitude will be zero if there is no signal. By cross-correlating the output of the detector with a rectangular wave of the same frequency and phase as the input switch, one could detect the signal with great sensitivity. Another possible method of achieving operation of this type has been used by Ewen¹ to detect the radiation from interstellar hydrogen. In his receiving system, the second local oscillator frequency was square-wave

frequency-modulated, carrying the relatively narrow-band signal first into and then out of the pass-band of the intermediate-frequency amplifier. The background noise powers in the two adjacent input bands are assumed equal. In what might again be considered a use of cross-correlation, a phase-sensitive detector was used to detect the presence of the resultant rectangular wave at the output of the last detector. Another such system might make use of a receiving transducer whose beam of sensitivity is steered or wobbled periodically. Such a system imposes a modulation on a signal received from a concentrated source, but not, perhaps, on the background noise received from a uniform distribution of background noise sources. After rectification, the received signal can be cross-correlated with a standard signal whose waveform and periodicity are chosen to match the beam pattern and the amplitude and frequency of wobble of the beam, to provide again a very sensitive method for detecting the presence of the signal in the output noise.

Systems such as these, which one might call post-detection correlation systems, cannot increase the output signal-to-noise ratio of the receiver to which they are applied. Systems such as the first two mentioned above represent simply a time-sharing method of measuring the difference between the rectified noise-plus-signal and the rectified noise, and their advantage lies in the fact that the large d-c output due to the background noise is cancelled out, and because of the time-sharing, the effects of drift in the receiver are also cancelled. Because half the time noise is being sent to the output without signal, one would reasonably expect the output signal-to-noise ratio to be less than for a single-channel system which looks at the signal-plus-noise continuously. For the same reason, one would expect that a system such as the third example above, which is receiving noise but little signal during the excursions of the beam away from the source, would produce a better signal-to-noise ratio if the beam were not being wobbled as it is slowly scanned past the source. Indeed, if one knew that this directional receiver must be used

to search at some fixed angular rate, one could specify the weighting function of the optimum filter for detecting a small signal. In this case, if the noise at the output of the rectifier were relatively wide-band, the optimum weighting function would have the same time-functional form as the signal which appears at the output of the rectifier as the receiver is scanned past a signal source. Because of the difficulty of constructing a passive filter with a weighting function resembling a beam pattern, one is sometimes led to substitute a cross-correlation procedure using an artificially-generated standard output signal for the optimum filtering operation. Only in cases of this type does post-detection correlation appear to hold a real possibility for improving the performance of a conventional receiving system. The loss in signal-to-noise ratio due to signal suppression which occurs in the first nonlinear device in the receiver is the most serious; later application of some correlation technique cannot necessarily make up the loss, if the total processing time and all else are the same.

References

1. Ewen, H. I., Radiation from Galactic Hydrogen at 1420 Megacycles per Second, Doctoral Thesis, Department of Physics, Harvard University, Cambridge, Massachusetts (May, 1951).

BIBLIOGRAPHY

American Standard Acoustical Terminology, American Standards Association, Inc., New York (July 31, 1951).

Beraneck, L. L., and H. P. Sleeper, Jr., "The Design and Construction of Anechoic Sound Chambers," J. Acoust. Soc. Am. 18, 140-150 (July 1946).

Brown, Robert F., Jr., "Frequency Independent "RC" Phase Shifter," J. Acoust. Soc. Am. 23, 623A (September 1951).

Eckart, Carl, The Measurement and Detection of Steady A.C. and D.C. Signals in Noise, University of California Marine Physical Laboratory of the Scripps Institution of Oceanography (October 4, 1951).

Electro-Acoustic Laboratory, Harvard University, The Design and Construction of Anechoic Sound Chambers, OSRD Report No. 4190, Cambridge, Massachusetts (October 15, 1945).

Ewen, H. I., Radiation from Galactic Hydrogen at 1420 Megacycles per Second, Doctoral Thesis, Department of Physics, Harvard University, Cambridge, Massachusetts (May 1951).

✓ Fano, R. M., Signal-to-Noise Ratio in Correlation Detectors, Technical Report No. 186, Research Laboratory of Electronics, Massachusetts Institute of Technology, Cambridge, Massachusetts (February 19, 1951).

Faran, J. J., Jr., and R. Hills, Jr., Correlators for Signal Reception, Technical Memorandum No. 27, Acoustics Research Laboratory, Harvard University, Cambridge, Massachusetts (September 15, 1952).

Hunt, F. V., "Perturbation and Correlation Methods for Enhancing the Space Resolution of Directional Receivers," Proc. I.R.E., 39, 840 (July 1951).

Icole, J., and J. Oudin, "Analyse Temporelle et Filtrage," Ann. Telecommun. 7, 99-108 (February 1952).

Jahnke, E., and F. Emde, Tables of Functions, 4th ed., Dover Publications, New York (1945), p. 149.

Lee, Y. W., T. P. Cheatham, Jr., and J. B. Wiesner, "Application of Correlation Analysis to the Detection of Periodic Signals in Noise," Proc. I.R.E., 38, 1165-1171 (October 1950).

Marsh, H. W., Jr., "Correlation in Wave Fields," A declassified portion of the Quarterly Report for the period ending March 31, 1950, U. S. Navy Underwater Sound Laboratory, New London, Connecticut.

Melton, B. S., and P. R. Karr, "A Proposal for the Determination of Coherence in a Signal Field," Paper 44, I.R.E. National Convention, New York (March 1952).

Miller, F. G., Development of the Type 48-A Power-Level Recorder, Technical Memorandum No. 10, Acoustics Research Laboratory, Harvard University, Cambridge, Massachusetts (August 15, 1949).

Nodtvedt, H., "The Correlation Function in the Analysis of Directive Wave Propagation," Phil. Mag. 42, 1022-1031 (September 1951).

Rudnick, Philip, The Detection of Weak Signals by Correlation Methods, University of California Marine Physical Laboratory of the Scripps Institution of Oceanography (May 10, 1952). ✓

Ryle, M., "A New Radio Interferometer and its Application to the Observation of Weak Radio Stars," Proc. Roy. Soc. A. 211, 351-375 (March 6, 1952).

Schuck, O. H., C. K. Stedman, J. L. Hathaway, and A. N. Butz, Jr., "Bearing Deviation Indicator for Sonar," Trans. AIEE 66, 1285-1295 (1947).

Stanford Research Institute, Final Report: Application of Techniques in the Reception of Single-Sideband Transmitted Signals, Stanford, California (March 30, 1951).

Project X

D i s t r i b u t i o n

1 Research and Development Board
 Pentagon Building
 Washington 25, D. C.

2 Chief of Naval Research
 Attn: Acoustics Branch, Code 411.
 Office of Naval Research
 Washington 25, D. C.

1 Director
 Naval Research Laboratory
 Washington 25, D. C.
 Attn: Technical Information Officer

 Commanding Officer
 U. S. Navy Office of Naval Research
 Branch Offices:

1 Boston
1 New York
1 Chicago
1 Pasadena

3 Officer in Charge
 Office of Naval Research
 Navy No. 100, Fleet Post Office
 New York, New York

1 Director
 U. S. Navy Underwater Sound
 Reference Laboratory
 Office of Naval Research
 Orlando, Florida

1 Director
 Naval Research Laboratory
 Sound Division
 Washington 20, D. C.

1 Director
 U. S. Naval Electronics Laboratory
 San Diego 52, California

1 U. S. Naval Academy
 Naval Postgraduate School
 Physics Department
 Monterey, California
 Attn: Prof. L. E. Kinsler

- 1 Director
Naval Ordnance Laboratory
White Oak's, Maryland
Attn: Sound Division
- 1 Director
Marine Physical Laboratory
University of California
U. S. Navy Electronics Laboratory
San Diego 52, California
- 1 Director
U. S. Navy Underwater Sound Laboratory
Fort Trumbull
New London, Connecticut
- 1 Director
David Taylor Model Basin
Carderock, Maryland
Attn: Sound Section
- 1 Director
Ordnance Research Laboratory
Pennsylvania State College
State College, Pennsylvania
- 1 Navy Department
Bureau of Ships
Washington 25, D. C.
Attn: Code 847
1 845
1 665E
- 1 Naval Medical Research Institute
Naval Medical Center
Bethesda, Maryland
Attn: LCDR D. Goldman, NMC
- 1 U. S. Undersea Warfare Committee
Navy Department
Washington 25, D. C.
- 1 Massachusetts Institute of Technology
Acoustics Laboratory
Cambridge 39, Massachusetts
Attn: Prof. R. H. Bolt

- 1 Catholic University of America
Washington 17, D. C.
Attn: Prof. K. F. Herzfeld
- 1 Brown University
Department of Applied Physics
Providence 12, Rhode Island
Attn: Prof. R. B. Lindsay
- 1 University of California
Department of Physics
Los Angeles, California
- 1 Princeton University
Department of Electrical Engineering
Princeton, New Jersey
- 1 Utah University
Salt Lake City 1, Utah
Attn: Dr. P. J. Elsey
- 1 Western Reserve University
Department of Chemistry
Cleveland, Ohio
Attn: Dr. Ernest Yeager
- 1 Commanding Officer
Naval Air Development Center
Johnsville, Pennsylvania
- 1 Woods Hole Oceanographic Institute
Woods Hole, Massachusetts
Attn: Mr. Vine
- 1 National Bureau of Standards
Sound Section
Washington 25, D. C.
- 1 California Institute of Technology
Pasadena, California
Attn: Dr. Epstein
- 1 Commanding Officer
Air Force Cambridge Research Laboratory
230 Albany Street
Cambridge 39, Massachusetts
- 1 Los Alamos Scientific Laboratory
P. O. Box 1663
Los Alamos, New Mexico
Attn: Dr. G. L. Campbell

- 1 Bell Telephone Laboratories
Murray Hill, New Jersey
Attn: Dr. W. E. Kock
- 1 U. S. Atomic Energy Commission
Library Section, Technical Information
Branch, ORE
P. O. Box E
Oak Ridge, Tennessee
Attn: Dr. I. A. Warheit
- 1 University of California
Radiation Laboratory
Information Division
Room 128, Bldg. 50
Berkeley, California
- 1 Lamont Geological Observatory
Torre Cliffs
Palisades, New York
- 1 Document Room
Research Laboratory of Electronics
Massachusetts Institute of Technology
Cambridge 39, Massachusetts
Attn: Mr. Hewitt
- 1 Federal Telecommunications Laboratory
500 Washington Avenue
Nutley, New Jersey
- 1 Hudson Laboratory
Columbia University
145 Palisades, Dobbs Ferry
New York
- 1 Director
Defense Research Laboratory
University of Texas
Austin, Texas
- 1 Director
David Taylor Model Basin
Carderock, Maryland
Attn: Technical Library
- 1 Walter G. Cady
Norman Bridge Laboratory
California Institute of Technology
Pasadena, California

- 1 Case Institute of Technology
Department of Physics
University Circle
Cleveland 6, Ohio
Attn: R. S. Shankland
- 1 California Institute of Technology
Department of Chemical Engineering
Pasadena, California
Attn: Dr. M. S. Plesset
- 1 Department of Electrical Engineering
U. S. Naval Academy
Annapolis, Maryland
- 1 Lois A. Noble, Librarian
The Brush Development Company
3405 Perkins Avenue
Cleveland 14, Ohio
- 1 Kellex Corporation
Silver Spring Laboratory
Silver Spring, Maryland
- 1 Technical Library
Bell Telephone Laboratories
Murray Hill, New Jersey
- 1 National Academy of Sciences
Committee on Undersea Warfare
2101 Constitution Avenue
Washington 25, D. C.
Attn: Dr. John S. Coleman
- 1 Commanding Officer
U. S. Naval Ordnance Test Station
Inyokern, California
Attn: Reports Unit

Reproduced by

Armed Services Technical Information Agency
DOCUMENT SERVICE CENTER

KNOTT BUILDING, DAYTON, 2, OHIO

AD -

9	4	2	5
----------	----------	----------	----------

UNCLASSIFIED