

UNCLASSIFIED

AD NUMBER

AD011100

CLASSIFICATION CHANGES

TO: unclassified

FROM: confidential

LIMITATION CHANGES

TO:
Approved for public release, distribution unlimited

FROM:
Distribution authorized to U.S. Gov't. agencies and their contractors; Administrative/Operational Use; 05 JUN 1953. Other requests shall be referred to National Aeronautics and Space Administration, Washington, DC.

AUTHORITY

NASA TR Server website; NASA TR Server website

THIS PAGE IS UNCLASSIFIED

Reproduced by

Armed Services Technical Information Agency

DOCUMENT SERVICE CENTER

KNOTT BUILDING, DAYTON, 2, OHIO

AD -

1 1 1 0 0

CONFIDENTIAL

CONFIDENTIAL

Copy
RM L53D16

NACA RM L53D16

AD No. 11100
ASTIA FILE COPY



RESEARCH MEMORANDUM

LOADS EXPERIENCED IN FLIGHTS OF TWO SWEEP-WING RESEARCH
AIRPLANES IN THE ANGLE-OF-ATTACK RANGE
OF REDUCED STABILITY

By Hubert M. Drake, Glenn H. Robinson, and Albert E. Kuhl

Langley Aeronautical Laboratory
Langley Field, Va.

CLASSIFIED DOCUMENT

This material contains information affecting the National Defense of the United States within the meaning of the espionage laws, Title 18, U.S.C., Secs. 793 and 794, the transmission or revelation of which in any manner to an unauthorized person is prohibited by law.

**NATIONAL ADVISORY COMMITTEE
FOR AERONAUTICS**

WASHINGTON

June 5, 1953

CONFIDENTIAL

NATIONAL ADVISORY COMMITTEE FOR AERONAUTICS

RESEARCH MEMORANDUM

LOADS EXPERIENCED IN FLIGHTS OF TWO SWEEP-WING RESEARCH
AIRPLANES IN THE ANGLE-OF-ATTACK RANGE
OF REDUCED STABILITY

By Hubert M. Drake, Glenn H. Robinson, and Albert E. Kuhl

SUMMARY

Loads measurements have been made with the swept-wing Bell X-5 and Douglas D-558-II research airplanes during flights in which reductions of longitudinal stability were experienced when the pilots attempted to perform routine test maneuvers at moderate values of lift. The horizontal-tail loads and pitching accelerations that were developed during pitch divergences are not considered to be excessive; however, the over-all airplane limit load could be inadvertently exceeded over a range of altitudes which varied widely with Mach number and was determined by the stability boundary and the maximum-lift boundary. At angles of attack above the stability boundary there was an inward shift of the lateral center of pressure which resulted in reduced bending moments. The vertical tail of the X-5 airplane was nearly as effective during lateral divergences at high angles of attack as it was at normal attitudes. Unexpectedly large internal wing structural loads were encountered during a spin resulting from a pitch-up of the X-5.

INTRODUCTION

A current, serious aerodynamic problem related to the high-speed flight of swept-wing airplanes is the tendency toward reduction of longitudinal stability found to occur at moderate values of lift. The resulting dynamic overshoot or pitch-up is the subject of much recent study. Such regions of reduced stability have been traversed during flight-test maneuvers of the Bell X-5 and Douglas D-558-II research airplanes which are being investigated by personnel of the NACA High-Speed Flight Research Station at Edwards Air Force Base, Calif. in cooperation with the Air Research and Development Command, U. S. Air Force, and the Bureau of Aeronautics, Department of the Navy, respectively.

Turn and pull-up maneuvers which were performed during the investigations were intended only to reach the stability boundary of the airplanes, but the reductions of stability caused the airplanes to pitch up to large angles of attack. At these high angles of attack, the D-558-II would occasionally, and the X-5 would usually, encounter a directional divergence which would result in large angles of sideslip and roll. This behavior was not unexpected and the maneuvers were therefore performed, whenever possible, at high altitudes in order to prevent the development of excessive loads. The loads that were experienced at angles of attack above the lift break are the subject of this report.

RESULTS AND DISCUSSION

Figure 1 shows the general arrangements of the X-5 and D-558-II airplanes. The X-5 has the horizontal tail located almost in line with the variable-sweep wing, which for the investigation with which this report is concerned was set at 59° sweepback of the quarter-chord line. The D-558-II airplane has 35° sweepback of the wing quarter-chord line and its horizontal tail is located in a relatively higher position, halfway up the vertical tail. The physical characteristics of these airplanes are described in greater detail in references 1 and 2.

The maximum angles of attack and sideslip measured during inadvertent maneuvers from turns and pull-ups are shown in figure 2 for each airplane. The line in the upper part of the figure is the stability boundary at which the airplane pitches, and the points indicate the peak values of angle of attack that have been attained as a result of this longitudinal divergence. The extreme angles of attack at low Mach numbers for the X-5 were encountered during a spin which resulted from the longitudinal and directional instabilities. The lower portion of figure 2 shows the angles of sideslip reached as a result of the directional instability at high angles of attack. No directional divergence has been encountered at supersonic Mach numbers with the D-558-II, but oscillations of the amplitude shown have been encountered during the recoveries from pull-ups.

Because the pitching motions result from stability deficiencies, rather than from control motions, it is of interest to see what range of pitching accelerations was encountered in these motions. In figure 3 are presented the accelerations attained both during the pitch-up and during the pitch-down in the recovery from the maneuver. Most of the pitch accelerations were smaller than 2 radians per second per second although a few were considerably larger. However, the Navy design requirement, 16 radians per second per second, was not exceeded, although it was approached by the D-558-II airplane.

Examples of the variations of horizontal-tail load during the pitch-ups are shown in figure 4. The variations with angle of attack of the airplane and wing normal-force coefficients are shown to indicate the lift conditions existing during the maneuver. The pitch-up, indicated by the ticks, usually occurs just before the break in the normal-force curve and the airplane is pitched to angles of attack near, or even exceeding, maximum lift. Were the pitch-up not present, the usable flight region would extend to higher lifts and be limited by the buffeting occurring at angles of attack near maximum wing lift, and the angles of attack beyond maximum lift normally would not be penetrated.

The horizontal-tail loads are shown in the center portion of figure 4. The curve labeled "structural" indicates the actual tail load measured by strain gages. Correcting this load for the tail-inertia load produced by the measured tail acceleration gives the curve entitled "aerodynamic." By use of the measured pitching angular accelerations the aerodynamic loads were corrected to a condition of zero pitching acceleration and are termed "balancing." The balancing tail loads at high angles of attack decrease to quite low values. The pitching of the airplane, however, produces a large positive increment and results in an aerodynamic load that continually increases with angle of attack. The structural load is relieved somewhat by the tail inertia, but has a variation similar to that of the aerodynamic load.

The envelope of the structural buffet loads encountered by the tail during these maneuvers is shown at the bottom of figure 4. Although not indicated in this figure, the X-5 buffets even at zero lift because its tail is almost directly behind the wing and is immersed in the disturbed wing wake. The magnitude of the buffeting is very low and is barely perceptible to the pilot. As the airplane pitches to high lift there is an increase in the buffet magnitude. The greatest magnitude that has been measured is about ± 400 pounds at 40,000 feet.

The buffeting of the D-558-II for the subsonic example shown in figure 4 starts at about 3° angle of attack as compared with about 16° angle of attack for the supersonic maneuver. There is an abrupt increase in magnitude as the linear lift range is exceeded, with a peak value of about $\pm 2,000$ pounds being reached at 24° angle of attack, after which the buffet loads decrease slightly. The peak buffet loads in the maneuver shown at supersonic speeds are smaller; however, maximum lift was not attained during this maneuver.

The maximum measured total structural tail loads, including buffet loads, were reached near a Mach number of 0.90 for both airplanes and did not exceed 1,500 pounds for the X-5 or 3,500 pounds for the D-558-II at 40,000 feet. A comparison of these values with the tail design loads indicates that in pitch-ups to these high angles of attack the limit load of the horizontal tail would not be exceeded at altitudes above 10,000 feet for either airplane.

The wing loads resulting from the instability are critical only for certain ranges of altitude, as shown in figure 5. The maximum lift determined at high altitude was used to establish the altitude above which the limit load factor, 7.33g, could not be exceeded; the variation of this altitude with Mach number is represented by the solid line in the figure. The dashed line represents the altitude variation below which the stability boundary cannot be reached without exceeding the limit load factor. The shaded area between the two lines is therefore the altitude range where the limit load factor may be inadvertently exceeded as a result of the instability. The upper boundary has not been defined through the entire Mach number range. Figure 5 shows that, for the present speed range of the X-5, flight testing above 30,000 feet should prevent inadvertently exceeding the limit load factor. The D-558-II, however, because of its large speed range, requires altitudes considerably above 50,000 feet if the region above the stability boundary is to be safely investigated at supersonic speeds. One point that this figure brings out is that the horizontal-tail loads discussed previously do not limit the airplanes anywhere in the flight range, as the over-all design limit load factor can be exceeded at higher altitudes than that at which the horizontal-tail loads become critical.

One change in the loading of the wing that results from the reduction of longitudinal stability is shown in figure 6. Here the measured variation of the lateral center of pressure of the additional air load with Mach number is shown for the stable flight range and for the region above the stability boundary. The lateral center-of-pressure location for the exposed wing area of the X-5 remains constant with Mach number at about 52 percent of the semispan in the stable range, but moves 20 to 25 percent inboard when the stability boundary is passed. The center of pressure for the D-558-II shows a similar, though smaller, shift inboard from the constant location it has in the stable range. These inboard shifts result in a decreased wing bending moment as the stability boundary is passed.

Turning now to loads resulting from lateral-stability deficiencies, figure 7 shows several lateral divergences at high lift for the X-5. In the top portion of the figure are shown the variations of angles of attack with sideslip existing during the divergences. The variations of unsymmetrical horizontal-tail load and aerodynamic vertical-tail load are shown in the lower plots. The large rolling and pitching motions accompanying these divergences are probably the cause of some of the variations in the measured loads. These vertical-tail-load measurements show that, even though the airplane has become directionally unstable, the vertical tail is still being loaded up as the airplane sideslips to large angles. The vertical-tail load per degree of sideslip measured for the X-5 in divergences over the Mach number range is slightly less than that measured in the normal flight range; this result indicates that only a slight reduction in the vertical-tail effectiveness occurs at

these large angles of attack. The vertical-tail loads measured would not be critical above about 15,000 feet if the same divergences were encountered at lower altitudes than those represented in the figure. The unsymmetric horizontal-tail loads measured during these maneuvers are non-linear and, although probably affected by the rolling motions, generally indicate positive effective dihedral through about 10° sideslip.

Mention might be made of one occurrence of unexpectedly high loads resulting from stability deficiencies of the X-5 airplane. A spin resulted from the longitudinal and directional instabilities at a Mach number of 0.7 and an altitude of 43,000 feet. As a result of the high rate of rotation in the spin, centrifugal forces tending to unsweep the wing were developed. This subjected the sweep mechanism to a compressive load three times greater than the maximum expected in normal flight at 59° sweep. Fortunately, the mechanism was designed for compression loads equal to the expected tension load, which was approximately the value obtained in the spin.

CONCLUDING REMARKS

The pitch accelerations and horizontal-tail loads developed during pitch divergences to high angles of attack with the X-5 and D-558-II airplanes were not excessive. The over-all airplane limit load could be inadvertently exceeded over a range of altitudes which varied widely with Mach number and was determined by the stability boundary and the maximum-lift boundary. At angles of attack above the stability boundary, there is an inward shift of the lateral center of pressure which results in reduced wing bending moments. The vertical tail of the X-5 was nearly as effective during lateral divergences at high angles of attack as it was at normal attitudes. Unexpectedly large internal wing structural loads were obtained during a spin resulting from a pitch-up.

Langley Aeronautical Laboratory,
National Advisory Committee for Aeronautics,
Langley Field, Va., April 8, 1953.

REFERENCES

1. Rogers, John T., and Dunn, Angel H.: Preliminary Results of Horizontal-Tail Load Measurements of the Bell X-5 Research Airplane. NACA RM L52G14, 1952.
2. Ankenbruck, Herman O., and Dahlen, Theodore E.: Some Measurements of Flying Qualities of a Douglas D-558-II Research Airplane During Flights to Supersonic Speeds. NACA RM L53A06, 1953.

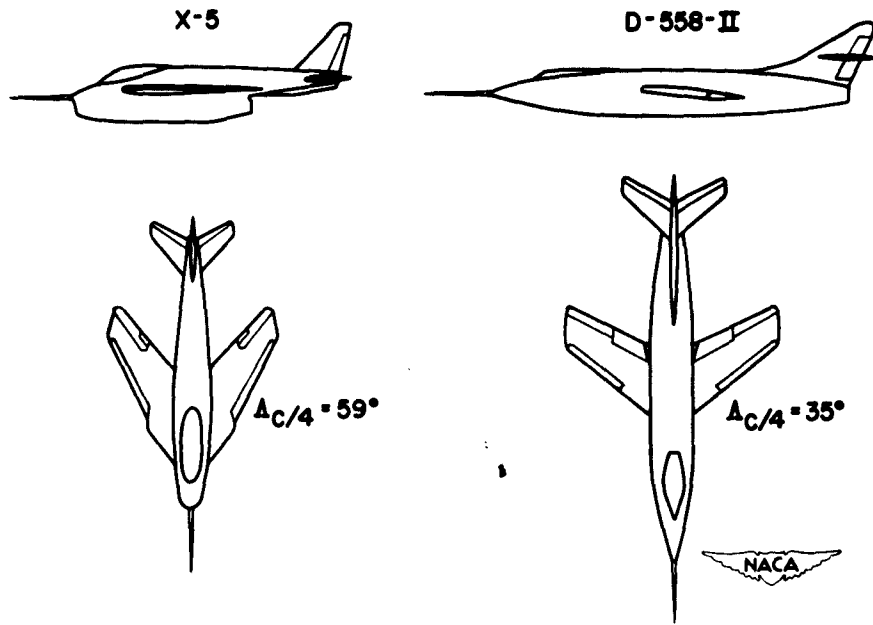

Figure 1.- General arrangements of X-5 and D-558-II research airplanes.

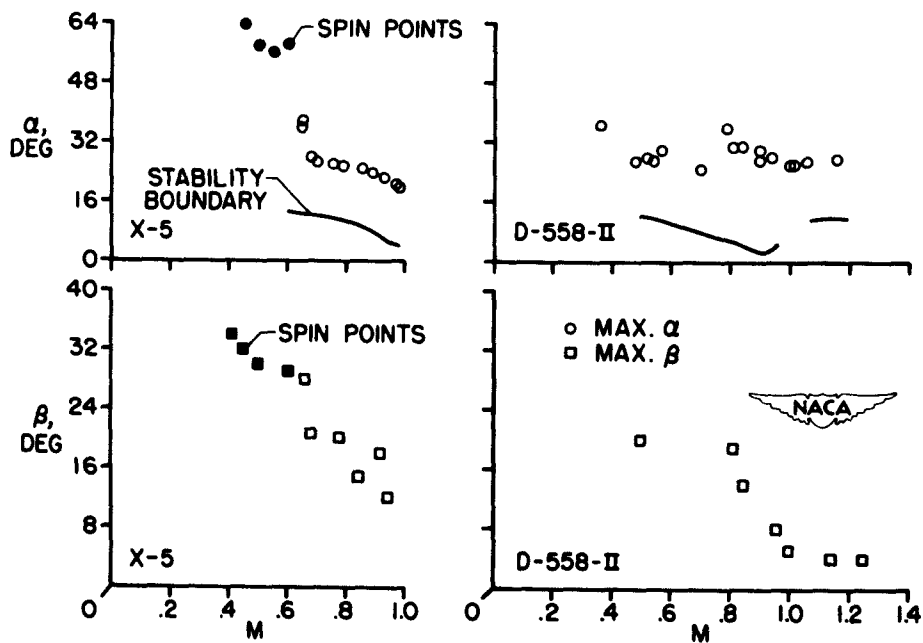

Figure 2.- Variations with Mach number of maximum angles of attack α and sideslip β measured during inadvertent maneuvers.

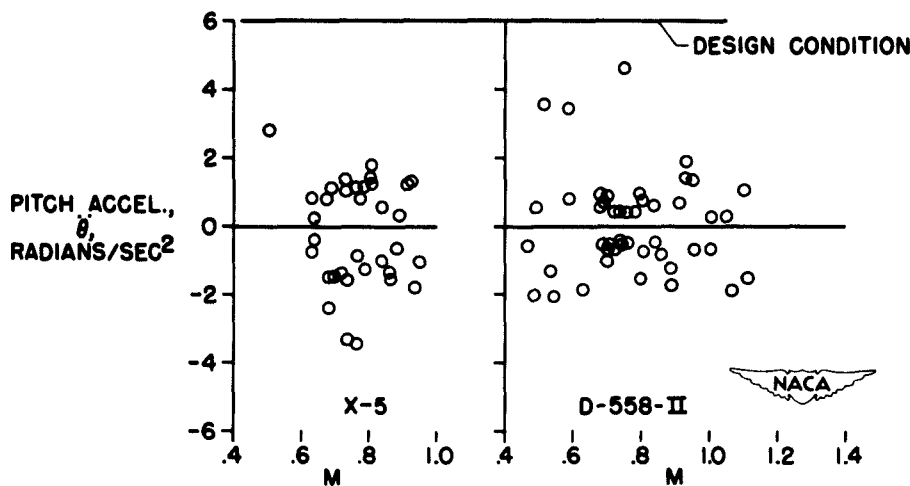

Figure 3.- Variation with Mach number of pitching acceleration $\ddot{\theta}$ measured during pitch-up and recovery.

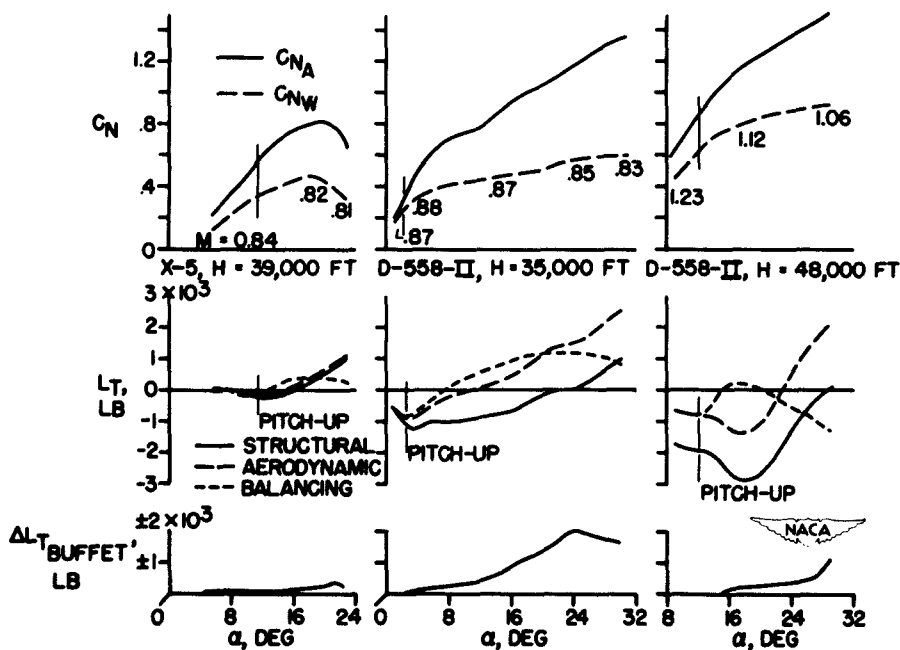

Figure 4.- Variations with angle of attack of airplane and wing normal-force coefficients C_{N_A} and C_{N_W} , horizontal-tail load L_T , and horizontal-tail buffet loads ΔL_{T_buffet} during pitch-ups experienced at subsonic and supersonic speeds.

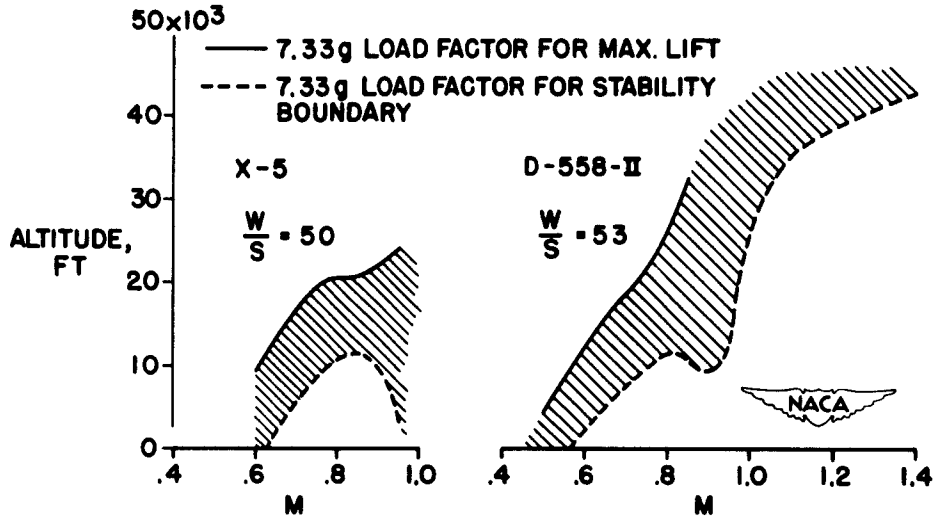

Figure 5.- Variation with Mach number of altitudes at which limit load factor may be inadvertently exceeded as a result of instability.

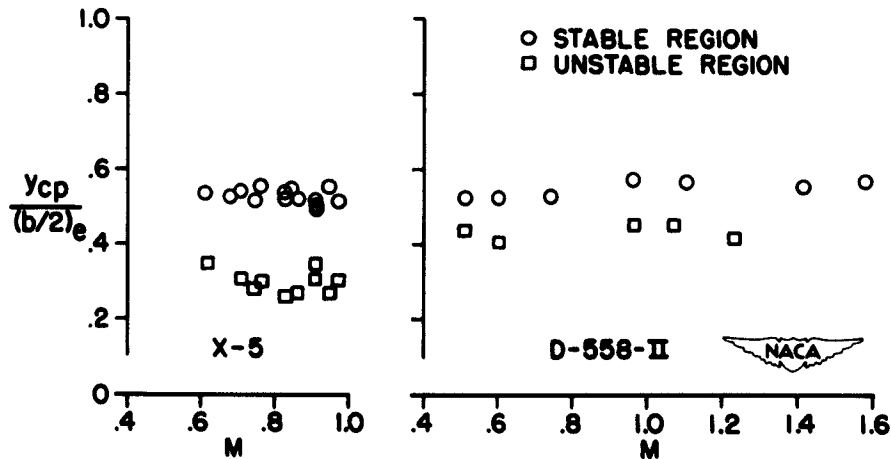

Figure 6.- Variation with Mach number of lateral center-of-pressure location, in terms of percentage of exposed-wing semispan, in the stable and unstable regions of flight.

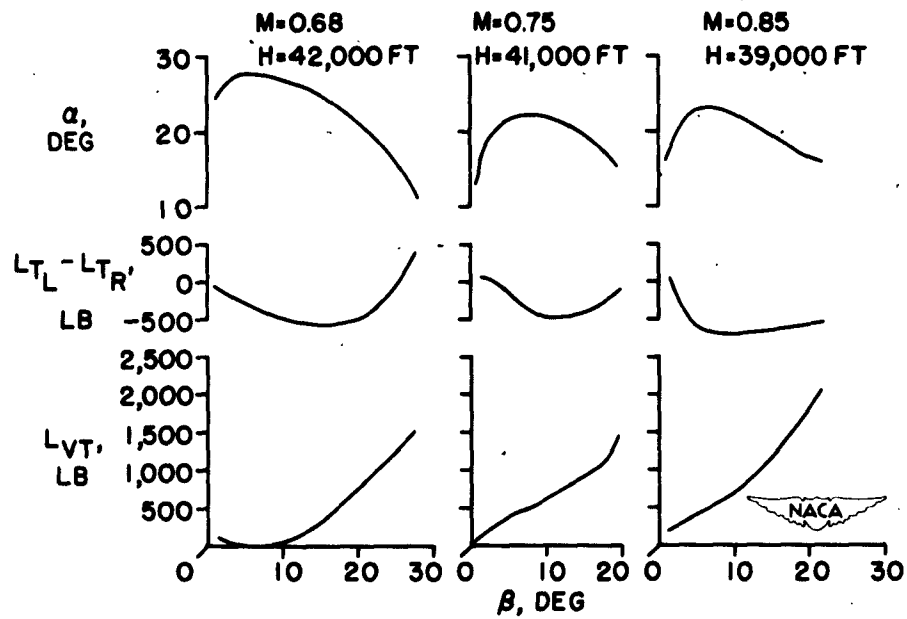

Figure 7.- Variations with angle of sideslip of angle of attack, unsymmetrical horizontal-tail load $L_{TL} - L_{TR}$, and aerodynamic vertical-tail load L_{VT} at high lift during directional divergences of the X-5 airplane.

NACA RM L53D16

National Advisory Committee for Aeronautics.
**LOADS EXPERIENCED IN FLIGHTS OF TWO
SWEEP-WING RESEARCH AIRPLANES IN THE
ANGLE-OF-ATTACK RANGE OR REDUCED
STABILITY.** Hubert M. Drake, Glenn H.
Robinson and Albert E. Kuhl. June 1953. 10p.
diags. (NACA RM L53D16) **CONFIDENTIAL**

Loads imposed upon the Bell X-5 and Douglas
D-558-II swept-wing research airplanes during
flights in which reductions of longitudinal stability
followed attempted moderate-lift maneuvers are
discussed. Information regarding horizontal- and
vertical-tail loads, wing loads, and normal-force
coefficients obtained during the high-angle-of-attack,
unstable portions of the flights are presented.

Copies obtainable from NACA, Washington

CONFIDENTIAL

SECURITY INFORMATION

1. Wings, Complete -
Sweep (1.2.2.2.3)
2. Stability, Longitudinal -
Dynamic (1.8.1.2.1)
3. Loads, Maneuvering -
Wings (4.1.1.1.2)
4. Loads, Maneuvering -
Tail (4.1.1.2.2)
- I. Drake, Hubert M.
- II. Robinson, Glenn H.
- III. Kuhl, Albert E.
- IV. NACA RM L53D16



CONFIDENTIAL

NACA RM L53D16

National Advisory Committee for Aeronautics.
**LOADS EXPERIENCED IN FLIGHTS OF TWO
SWEEP-WING RESEARCH AIRPLANES IN THE
ANGLE-OF-ATTACK RANGE OR REDUCED
STABILITY.** Hubert M. Drake, Glenn H.
Robinson and Albert E. Kuhl. June 1953. 10p.
diags. (NACA RM L53D16) **CONFIDENTIAL**

Loads imposed upon the Bell X-5 and Douglas
D-558-II swept-wing research airplanes during
flights in which reductions of longitudinal stability
followed attempted moderate-lift maneuvers are
discussed. Information regarding horizontal- and
vertical-tail loads, wing loads, and normal-force
coefficients obtained during the high-angle-of-attack,
unstable portions of the flights are presented.

Copies obtainable from NACA, Washington

CONFIDENTIAL

SECURITY INFORMATION

1. Wings, Complete -
Sweep (1.2.2.2.3)
2. Stability, Longitudinal -
Dynamic (1.8.1.2.1)
3. Loads, Maneuvering -
Wings (4.1.1.1.2)
4. Loads, Maneuvering -
Tail (4.1.1.2.2)
- I. Drake, Hubert M.
- II. Robinson, Glenn H.
- III. Kuhl, Albert E.
- IV. NACA RM L53D16



CONFIDENTIAL

NACA RM L53D16

National Advisory Committee for Aeronautics.
**LOADS EXPERIENCED IN FLIGHTS OF TWO
SWEEP-WING RESEARCH AIRPLANES IN THE
ANGLE-OF-ATTACK RANGE OR REDUCED
STABILITY.** Hubert M. Drake, Glenn H.
Robinson and Albert E. Kuhl. June 1953. 10p.
diags. (NACA RM L53D16) **CONFIDENTIAL**

Loads imposed upon the Bell X-5 and Douglas
D-558-II swept-wing research airplanes during
flights in which reductions of longitudinal stability
followed attempted moderate-lift maneuvers are
discussed. Information regarding horizontal- and
vertical-tail loads, wing loads, and normal-force
coefficients obtained during the high-angle-of-attack,
unstable portions of the flights are presented.

Copies obtainable from NACA, Washington

CONFIDENTIAL

SECURITY INFORMATION

1. Wings, Complete -
Sweep (1.2.2.2.3)
2. Stability, Longitudinal -
Dynamic (1.8.1.2.1)
3. Loads, Maneuvering -
Wings (4.1.1.1.2)
4. Loads, Maneuvering -
Tail (4.1.1.2.2)
- I. Drake, Hubert M.
- II. Robinson, Glenn H.
- III. Kuhl, Albert E.
- IV. NACA RM L53D16



CONFIDENTIAL

NACA RM L53D16

National Advisory Committee for Aeronautics.
**LOADS EXPERIENCED IN FLIGHTS OF TWO
SWEEP-WING RESEARCH AIRPLANES IN THE
ANGLE-OF-ATTACK RANGE OR REDUCED
STABILITY.** Hubert M. Drake, Glenn H.
Robinson and Albert E. Kuhl. June 1953. 10p.
diags. (NACA RM L53D16) **CONFIDENTIAL**

Loads imposed upon the Bell X-5 and Douglas
D-558-II swept-wing research airplanes during
flights in which reductions of longitudinal stability
followed attempted moderate-lift maneuvers are
discussed. Information regarding horizontal- and
vertical-tail loads, wing loads, and normal-force
coefficients obtained during the high-angle-of-attack,
unstable portions of the flights are presented.

Copies obtainable from NACA, Washington

CONFIDENTIAL

SECURITY INFORMATION

1. Wings, Complete -
Sweep (1.2.2.2.3)
2. Stability, Longitudinal -
Dynamic (1.8.1.2.1)
3. Loads, Maneuvering -
Wings (4.1.1.1.2)
4. Loads, Maneuvering -
Tail (4.1.1.2.2)
- I. Drake, Hubert M.
- II. Robinson, Glenn H.
- III. Kuhl, Albert E.
- IV. NACA RM L53D16



CONFIDENTIAL