

UNCLASSIFIED

AD NUMBER

AD011212

CLASSIFICATION CHANGES

TO: unclassified

FROM: confidential

LIMITATION CHANGES

TO:  
Approved for public release, distribution unlimited

FROM:  
Distribution authorized to DoD only;  
Foreign Government Information; APR 1953.  
Other requests shall be referred to  
British Embassy, 3100 Massachusetts  
Avenue, NW, Washington, DC 20008.

AUTHORITY

DSTL, DEFE 15/620, 19 Feb 2009; DSTL, DEFE  
15/620, 19 Feb 2009

THIS PAGE IS UNCLASSIFIED

Reproduced by

Armed Services Technical Information Agency

DOCUMENT SERVICE CENTER

KNOTT BUILDING, DAYTON, 2, OHIO

AD -

1 1 2 1 2

CONFIDENTIAL

AD 14 212

ASTIA FILE COPY

21/52

CONFIDENTIAL

COPY No. 15



MINISTRY OF SUPPLY

ARMAMENT RESEARCH ESTABLISHMENT

MEMO No. 21/52

WEAPONS RESEARCH DIVISION

An Improved Spark Gap of Small Dimensions  
for Fast Shadow Photography

... H. F. Hills

CONFIDENTIAL

Ministry of Supply

ARMAMENT RESEARCH ESTABLISHMENT

M 210 No. 21/52

Weapons Research Division

An Improved Spark Gap of small dimensions  
for fast Shadow Photography

H.F. Hills

Summary

The development of a spark gap to provide sparks of increased brightness, short duration, small overall dimensions, ease of adjustment and safety in operation, has been carried out by use of a modified Libessart type of gap.

Approved

..... *J. J. Harris* ..... Superintendent  
..... *W. Blackman* ..... Senior Superintendent

CONFIDENTIAL

**IMPORTANT**

*This DOCUMENT should be returned to the Chief Information Officer, Armament Research Establishment, Fort Halstead, Sevenoaks, Kent, if retention becomes no longer necessary.*

**INITIAL DISTRIBUTION**

**Internal**

No. 1	CSAR
2	SSWR
3 - 5	SWR (Cambridge)
6	SWR (Swynnerton)
7	Mr. H. F. Hills
8 - 9	WR Records

**United Kingdom**

10 - 11	CS/ERDE
12 - 13	DWR(D)

**Overseas (through TPA3/TIB)**

14 - 31	US - Joint Reading Panel
32	- R & D Board
33 - 36	. BJSM (incl. Naval Staff) for own use only
37	Canada - Dept. Nat. Def.
38 - 41	- Def. Res. Liaison
42	- Nat. Res. Council
43 - 44	TPA3/TIB - Retention

**Stock**

45 - 60

Contents.

Section

1. Introduction
2. Conditions imposed by the Multiple Spark Layout
3. Spark gaps.
4. Theoretical Considerations
5. Gap Construction
6. First Trial
7. Second Trial.
8. Electrodes of different metals.
9. Third Trial
10. Photography
11. Results

Appendix.

- I Construction of Spark Gaps
- II. Old design of Spark Rack.
- III. New layout of " "

## 1. Introduction

In the field of Ballistics Research where Multiple Spark Photography is used for recording many kinds of high speed phenomena, there has always been the need for a reliable point source of light with very high intensity and shorter duration than that obtainable from the magnesium tipped electrodes used at present.

## 2. Conditions Imposed by the Multiple Spark Layout

These are found to be quite impressive.

- (1) Very high light intensity from a point source.
- (2) Shortest possible light duration from the discharge.
- (3) Very good electrical screening of the gaps to prevent radiation from the discharge of any one gap affecting other adjacent ones.
- (4) Electrode material to be hard wearing and give shorter light duration than magnesium.
- (5) Dimensions to be kept down to a minimum in order to reduce perspective in the photographs.
- (6) Operational safety.
- (7) Ease of adjustment in a confined space.
- (8) Easy removal and replacement.
- (9) Maximum discharge voltage not to exceed 10 KV. so that surface leakage, due to humidity, may be reduced to a minimum.

## 3. Spark Gaps

The spark gaps, which have been in constant use for many years in the Multiple Spark Ranges, have three adjustable electrodes tipped with magnesium for the main and trigger gaps, each pair of gaps being shielded from the neighbouring twenty-four pairs. (Appendix 1 - Fig. 1). At this time magnesium was considered to be the best electrode material for maximum brightness, but it was generally understood that light was being obtained at the expense of longer light duration and this became evident by the drawing out of the images when photographs were taken of projectiles with velocities at 3000 ft/second and over.

## 4. Theoretical Considerations

It is well known that the light intensity of a spark gap, where conditions in the discharge circuit remain unchanged, increases, as the volume in which the discharge takes place is diminished, i.e. as the pressure in the discharge path increases. Increasing the pressure may be achieved by enclosing the gap in a pressurised chamber or glass tube or Argon e.g. the Arditron Flash Tube, or by confining the discharge path of an air gap, in the form originally adopted by General Paul Libersart, of France. Using 25 flash tubes was not a practical proposition because

Best Available Copy

of overall size, length of light source and total energy required.

It was therefore decided to construct a spark gap which could be viewed end on, and thus save valuable space.

#### 5. Gap Construction

Fig. 2 shows the arrangement of the gap which was first tried out (light from the new trigger gap was not photographed in any of the trials although light from both main and trigger gaps is included in the old type gaps).

Magnesium was used as electrode material so that a direct light comparison could be made with one of the old type gaps by recording them both on the same photographic plate, with suitable separation, so that each picture received the same development time.

Insulation round the positive and negative electrodes is of Keramot and at the end nearest to the electrode tip, dishing has been carried out to lengthen the surface leakage path to earth should the insulation become affected by humidity. Adjustment of the gap is carried out by either screwing in or out the front cap which carries the earthed electrode.

Both the positive and negative electrodes are hemispherical in shape to give the most uniform spark and maximum stability in operation. (Pointed electrodes tend to set up corona and increased gap distance is necessary to prevent sparking over. Duration is also affected).

#### 6. First Trial

A new gap was set up in place of one of the old ones and an adjacent old gap was used for purposes of comparison.

Each of the two sources of light was made to fall on its own camera lens, and the exposures were made on the same photographic plate, with normal separation of the images. After processing, background intensities were compared, and it was seen that the light intensity of the new gap was very much less than that of the old one.

An improvement was obtained by increasing the pinhole to  $1/16^{\text{th}}$  inch diameter and a further gain in light was obtained by increasing the hole to  $1/8^{\text{th}}$  inch diameter.

Light intensities of the two gaps were then very approximately of the same order.

#### 7. Second Trial

Closer confinement of the gap was next carried out, Fig. 3. and with  $1/8^{\text{th}}$  inch diameter pinhole a great gain in light intensity was apparent, the background recorded by the new gap being considerably darker than the other one.

The pinhole diameter was reduced in three stages to .012 inches and light intensity increased with each reduction. Reduction of the capacity from 0.2  $\mu\text{fd}$  to 0.1  $\mu\text{fd}$  in the unit controlling the new gap reduced the light intensity but there was still a great gain over the older one.

More careful alignment of the electrodes, and tighter fitting of the perspex insulating sleeve on the positive electrode increased the brightness still more, by effectively preventing leakage of pressure past

the electrode, the 0.012 inch diameter hole being the only vent for the discharge pressure.

#### 8. Electrodes of different metals

The magnesium electrodes in the new gap were replaced in turn by copper, brass, steel and combinations of these metals with no perceptible improvement or falling off of intensity. After the discharge of 1000 sparks the hole in the steel electrode showed no increase in size when measured under the Cambridge measuring machine. The enlargement must therefore have been less than 0.01 mm.

#### 9. Third Trial

To assess the effective photographic intensity and duration of light from the two test gaps, firings were made with 20 mm Hispano Ball Ammunition at a velocity of 3000 ft/por second, and photographs taken of the projectile in flight to determine how much dragging out of the image was present. The new gap was first fitted with brass electrodes and the record indicated that the spark duration was excessive. The discharge circuit was then checked over, and it was found that longer leads than were necessary had been connected between the spark unit and the gap, thus causing a change in value of inductance, capacity and surge resistance. By shortening these leads, and using heavier conductors the duration of the spark discharge was considerably reduced, and critical damping, found to be 5 ohms, was then applied with further beneficial results.

A reduction in light intensity had to be accepted due to losses in the damping resistance but there was still ample light for photographic purposes.

Similar tests were then carried out to see if any light improvement could be gained by using other metal electrodes in place of the brass ones.

There seemed to be no difference in light intensity between any of the metals tried i.e. brass, copper, magnesium and steel, but magnesium gave longer spark duration. It was therefore decided to adopt the steel electrodes with their harder wearing qualities, as standard.

#### 10. Photography

The circuit characteristics from the photographic point of view are of fundamental importance as they control the rate of rise of the light intensity to its peak value and the initial decay rate. Decreasing circuit inductance increases the rate of rise, while broadening of the peak is increased by inductance and capacity.

Also of very great importance is the choice of suitable photographic plates, because apparent photographic duration of the spark discharge depends on the speed and colour sensitivity of the plates used.

As the light from these sparks is very rich in the blue violet part of the spectrum, Ilford Slow Process, Kodak B.4. Half Tone, or any slow plate which is only sensitive to the blue violet should be used so that the apparent photographic duration will be reduced to a minimum.

Faster blue sensitive plates will increase the apparent duration.

Spark discharges have been recorded by using a large aperture lens, high speed revolving mirror and very fast sensitive films, and these records show a total light duration of about 40 micro seconds.

The reason for this careful choice of photographic plate can now be seen. By using the slow blue violet sensitive type of plate, no blue or violet filter need be used as the plate is self filtering, the longer wave lengths of light which were also recorded in the above test will be filtered out, and apparent duration reduced to the point where it cannot be resolved.

## 11. Results

1. The conditions imposed have all been met, although from the point of view of the discharge duration a compromise has had to be made once more.

A great gain has been obtained in light output which has enabled the value of the discharge condenser to be reduced from 0.2 ufd to 0.1 ufd, and the source has been reduced to a point.

2. Light duration has been reduced by (a) adopting steel electrodes in place of magnesium.  
(b) Cutting down the value of the discharge condenser by 50 per cent.
3. Electrical screening of the gap has been very greatly improved as the 'live' electrode is practically surrounded by the other electrode at earth potential.
4. Steel electrodes are harder wearing than magnesium and they do not leave a coating of conducting oxide on the insulated parts after sparking. Shorter light duration is also obtained when steel electrodes are used in place of magnesium.
5. In the old type spark rack the gap centres were  $2\frac{1}{2}$  inches apart, leading to quite appreciable perspective differences in the photographs. The new gaps can be set up at  $1\frac{1}{16}$  inch apart and a smaller gap which has just been completed will enable the distance to be reduced to  $\frac{3}{8}$  inch.
6. Operational safety has been achieved by enclosing the high voltage electrodes inside the earthed body containing the second electrode.
7. A fine screw adjustment is incorporated in the front cap carrying the pinhole electrode, and is easily accessible.
8. Removal of the complete spark gap from the rack is easily carried out by unscrewing or where only the pinhole electrode requires renewal the cap is simply screwed off.
9. With the extra light now available it is possible to reduce the discharge voltage to 8 K.V. Six Forspox shoots have to be included in the Multiple Spark set up as a protection against damage to the large condensing lens by flying fragments of shot or armour plate, and the 12 reflecting surfaces cause loss of light, otherwise a still smaller discharge condenser could be used with a further shortening of spark duration.

APPENDIX I

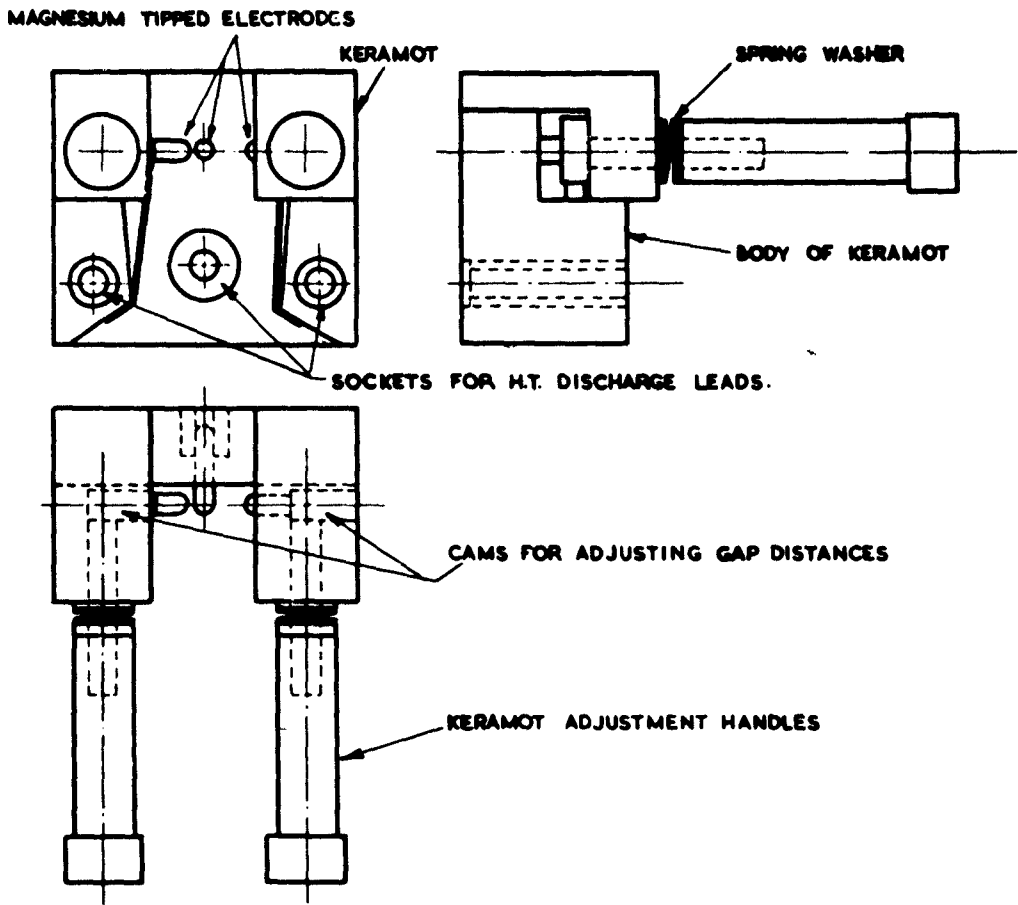

FIG. 1

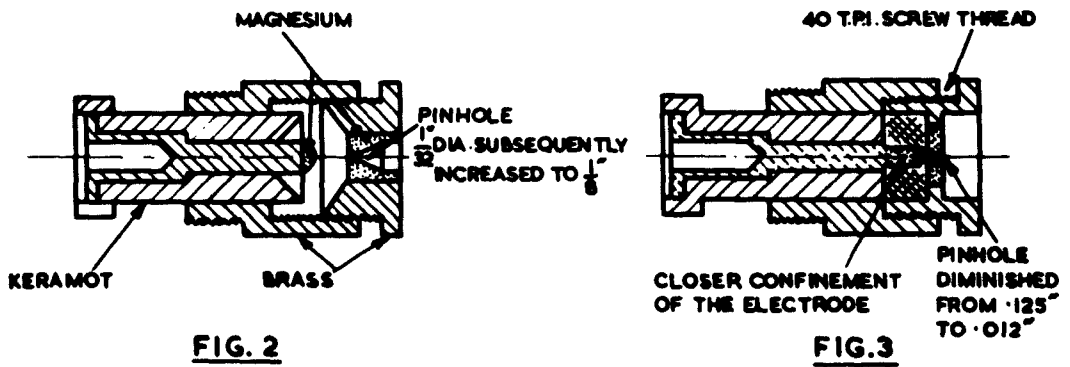

FIG. 2

FIG. 3

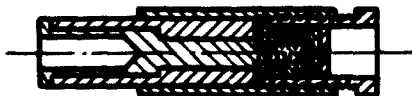
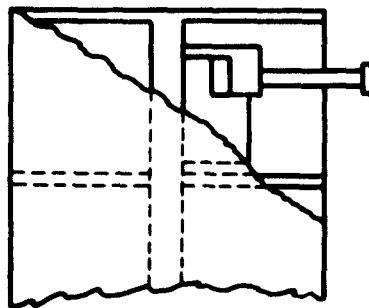
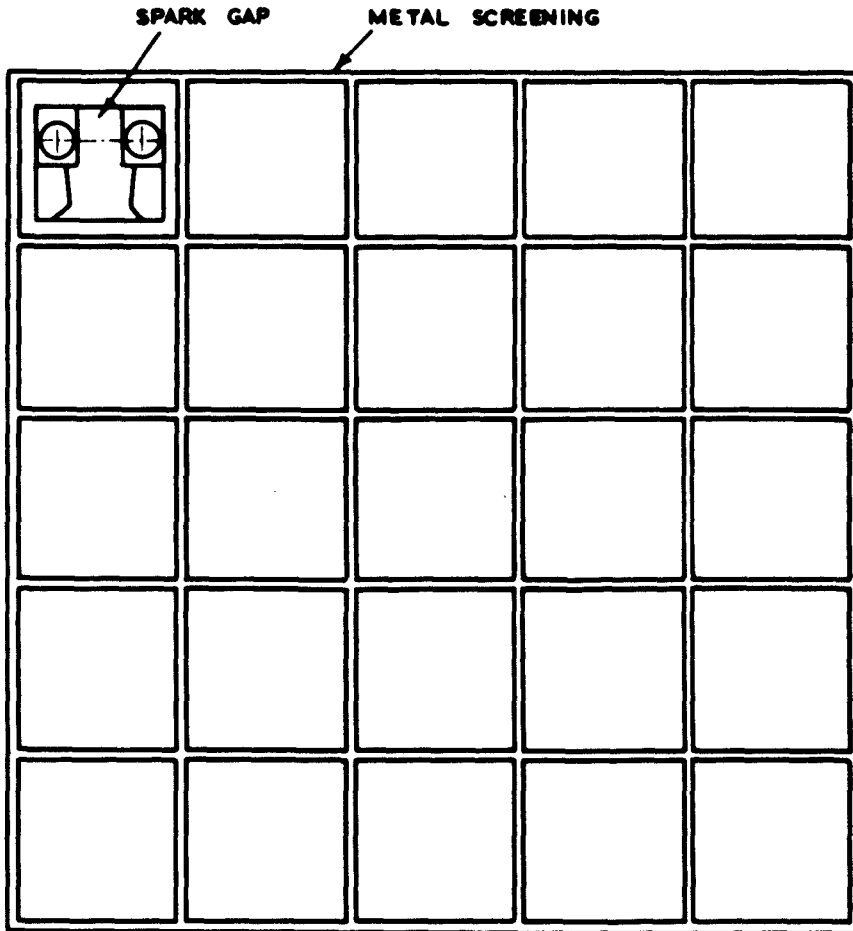

FIG. 4

APPENDIX II

CONFIDENTIAL

OLD TYPE SPARK RACK



CONFIDENTIAL

**APPENDIX III**

**DESIGN OF SPARK RACK SHOWING CLOSER  
SPACING OF THE GAPS.**

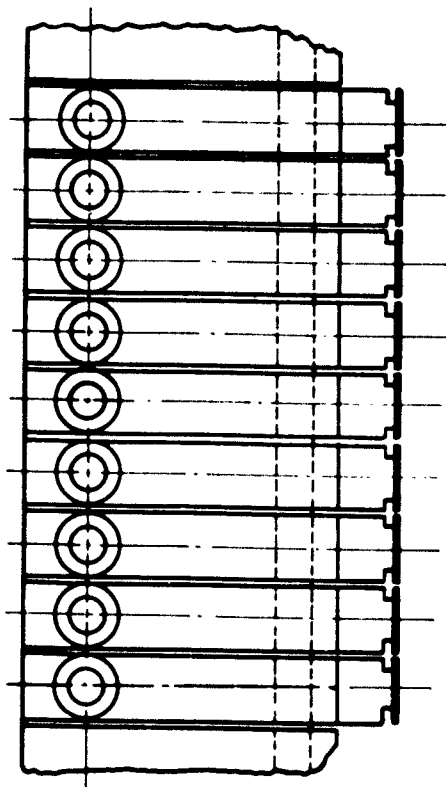

**FRONT ELEVATION**

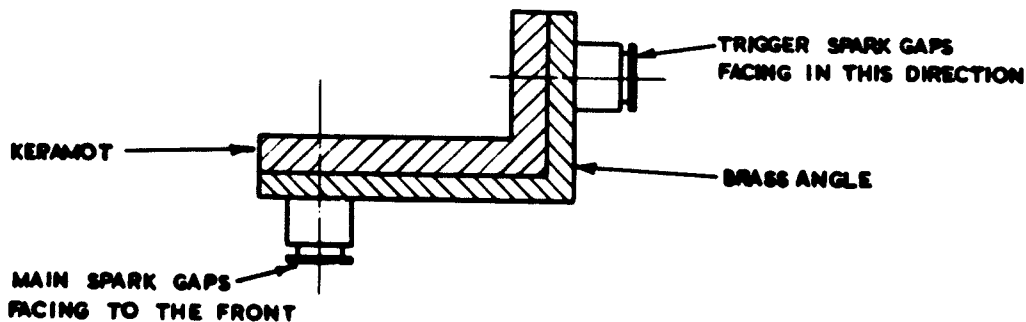

**PLAN**



[dstl]

Defense Technical Information Center (DTIC)  
8725 John J. Kingman Road, Suit 0944  
Fort Belvoir, VA 22060-6218  
U.S.A.

AD#: AD011212

Date of Search: 19 February 2009

Record Summary: DEFE 15/620

An improved spark gap of small dimensions for fast shadow photography  
Former reference (Department): Memo No 21/52  
Held by The National Archives, Kew

This document is now available at the National Archives, Kew, Surrey, United Kingdom.

DTIC has checked the National Archives Catalogue website (<http://www.nationalarchives.gov.uk>) and found the document is available and releasable to the public.

Access to UK public records is governed by statute, namely the Public Records Act, 1958, and the Public Records Act, 1967. The document has been released under the 30 year rule. (The vast majority of records selected for permanent preservation are made available to the public when they are 30 years old. This is commonly referred to as the 30 year rule and was established by the Public Records Act of 1967).

This document may be treated as **UNLIMITED**.