

UNCLASSIFIED

AD NUMBER	
AD011686	
CLASSIFICATION CHANGES	
TO:	unclassified
FROM:	restricted
LIMITATION CHANGES	
TO:	Approved for public release, distribution unlimited
FROM:	Distribution authorized to DoD only; Foreign Government Information; APR 1952. Other requests shall be referred to British Embassy, 3100 Massachusetts Avenue, NW, Washington, DC 20008.
AUTHORITY	
DSTL, DEFE 15/327, 27 Oct 2008; DSTL, DEFE 15/327, 27 Oct 2008	

THIS PAGE IS UNCLASSIFIED

UNCLASSIFIED

AD NUMBER
AD011686
CLASSIFICATION CHANGES
TO
restricted
FROM
secret
AUTHORITY
RARDE Notice dtd 30 Jun 1971

THIS PAGE IS UNCLASSIFIED

Reproduced by

Armed Services Technical Information Agency

DOCUMENT SERVICE CENTER

KNOTT BUILDING, DAYTON, 2, OHIO

AD -

1	1	6	8	6
---	---	---	---	---

SECRET

Report No.
A.D.E. 9/52

SECRET

Report No.
A.D.E. 9/52

Copy No. 35

AD No. 1168b
ASTIA FILE COPY

ARMAMENT DESIGN ESTABLISHMENT
MINISTRY OF SUPPLY

THE DETERMINATION OF THE OPTIMUM SIZE OF A.P.C.B.C./D.S.
SHOT AND OF THE TUNGSTEN CORE OF A.P./D.S. PROJECTILE
FOR MAXIMUM PERFORATION OF ARMoured PLATE

By THE DIRECTOR, A.D.E.

F. BOOKER

NOTICE

OFFICIAL SECRETS ACTS

Any unauthorized person finding this document
should read the instructions on the back cover.

SECRET

ARMAMENT DESIGN DEPARTMENT

TECHNICAL REPORT

No. A.D.R. 9/52

THE DETERMINATION OF THE OPTIMUM SIZE OF A.P.C.B.L./D.S. SHOT AND OF
THE TUNGSTEN CORE OF A.P./D.S. PROJECTILE FOR MAXIMUM PERFORATION OF
ARMOUR PLATE.

F. BOCKEN, A.M.I.Mech.E.

Recommended for publication

[Signature]
Col. G. F. Roberts, D.F.

Approved for publication

[Signature]
P. P. Wickens, C.R.A.D.

Abstract

In this paper the optimum sizes of A.P.C.B.L./D.S. shot and A.P./D.S. Tungsten cores for perforating armour plate are determined.

It is shown that the values are given approximately by the ratios:-

Shot calibre/full calibre $\frac{1}{2}$ \uparrow
Tungsten core calibre/full calibre $\frac{1}{2}$ \uparrow

but more accurate values, which depend upon the ballistic weights and the range, can be determined. It is concluded also that slight reduction in these ratios may be adopted if necessary without seriously reducing the thickness of plate perforated.

Armament Design Establishment,
Ministry of Supply,
Fort Halstead, Kent.

Phone: Sevenoaks 5211

April, 1952

SECRET

**THE DETERMINATION OF THE OPTIMUM SIZE OF A.P.C.B.C./D.S. SHOT AND OF
THE TUNGSTEN CORE OF A.P./D.S. PROJECTILE FOR MAXIMUM
PERFORATION OF ARMOUR PLATE**

Introduction.

Discarding Shot Projectiles comprise in the main, a shot of calibre smaller than the gun and fitted with a light alloy body (the discarding sabot) whose calibre suits the gun bore and centres the shot.

By this construction a higher velocity is given to the shot than could be obtained if fired from a gun of calibre equal to the shot; and the velocity at the target would be correspondingly higher for perforation.

Perforation of the target is dependent upon the weight, diameter and velocity of the shot and as it is possible to design a D.S. projectile with varying sizes of shot it is required to know the best size which will effect maximum perforation of the plate.

Assumptions.

The assumptions made in this paper are those also given in A.R.E. Weapons Branch Memo No. 1/57

- (a) Internal ballistic relations--
(Projectile weight plus half the charge) times the square of the muzzle velocity is constant for the same charge at all velocities.
- (b) Shatter does not occur in any case
- (c) The projectiles are stable
- (d) The weight of the discarding components of the projectiles is constant for the same type of projectile
- (e) $\log_{10} C$ used in the De Maria formula, for a given angle of impact, is constant
- (f) The muzzle velocities considered cover 3700-6000 ft/sec.

It is also stated that

- (a) is a near enough approximation
- (b) is an anticipation
- (c) can be made true
- (d) A.R.E. and A.D.S. find from experience that this is reasonably true
- (e) this has not been convincingly disproved by experiments

Range - Velocity Equation

The normal method for determining the velocity of shot at various ranges is that due to Siacchi.

This method does not lend itself to being introduced into the problem and, in the following, a simple equation relating range and velocity is obtained.

One form of the resistance equation is $\frac{1}{2} \rho C_D V^2 A \left(\frac{V}{a}\right)^n$, where "a" is the velocity of sound in air.

The Text Book of Ballistics and Gunnery 1946 also states that a reasonable fit for velocities between 3700 and 6000 ft/sec is given by

$$\text{Resistance} = KV^{1.8}$$

Hence we can write the resistance in the form

$$K_1(K\sigma)d^2V^{1.8}$$

where K and K_1 are ballistic constants and the equation of motion may be written

$$\begin{aligned} \frac{W}{g} \frac{dV}{dt} &= -K_1(K\sigma)d^2V^{1.8} \\ V \frac{dV}{dx} &= -\frac{K_1(K\sigma)d^2g}{W} V^{1.8} \end{aligned}$$

$$\text{which leads to } x = \frac{W}{K_1(K\sigma)d^2g} \cdot \frac{1}{.8} (V_0^2 - V_x^2) \quad (1)$$

where
 x = range in ft.
 V_x = velocity at range x .
 d = diameter of ball in ft.
 W = weight of ball in lb.

Table I gives the values of $K_1(K\sigma)$ determined from the results obtained by the Siacchi method for four subprojectiles at the ranges 500, 1000 and 2000 yds.

TABLE I

Sub Projectile	W lb.	d ins.	x feet	V_0 f/s	V_x f/s	$K_1(k\sigma)$	Mean $K_1(K\sigma)$	$K_2(K\sigma)$	Mean $K_2(K\sigma)$
A	6.78	2.08	1500	5230	5032	.1676		.9251	
B	11.8	2.515	1500	4700	4536	.1687	.1685	.9122	.9048
C	14.32	2.675	1500	4400	4249	.1680		.9009	
D	21.82	3.062	1500	3910	3783	.1690		.8812	
A	6.78	2.08	3000	5230	4835	.1678		.9228	
B	11.8	2.515	3000	4700	4373	.1688	.1683	.9094	.9003
C	14.32	2.675	3000	4400	4100	.1683		.8949	
D	21.82	3.062	3000	3910	3658	.1683		.8742	
A	6.78	2.08	6000	5230	4446	.1680		.9158	
B	11.8	2.515	6000	4700	4050	.1690	.1686	.9039	.8948
C	14.32	2.675	6000	4400	3804	.1684		.8889	
D	21.82	3.062	6000	3910	3408	.1688		.8707	

.1685

.9

Taking the mean value of $K_1(K\sigma)$

$$x = 11.06 \frac{W}{d^2} (V_0^2 - V_x^2) \quad (2)$$

where d is in inches
 x is in yards.

A simpler form may be produced by assuming the resistance varies as the velocity thus

$$\text{Resistance} = K_2(K\sigma)d^2V$$

$$\text{giving } x = \frac{W}{K_2(K\sigma)gd^2} \ln \frac{V_1 - V_2}{V_1} \quad \text{where } x = \text{feet} \quad (3)$$

$$d = \text{ins}$$

The values of $K_2(K\sigma)$ are also given in Table I showing, they are reasonably constant. Using the mean value we have

$$X = \frac{1.656W}{d^2} (\frac{V_1 - V_2}{V_1}) \quad (4)$$

where X is in yards
W is in lb
d is in ins.
V is in ft/sec.

The projectiles considered in this paper have the same $(K\sigma)_1$ value of 1.1 and therefore equation (4) will be used throughout. If, however, the form of the shot is changed, giving a new value $(K\sigma)_2$, the range X as determined by equation (4) is changed to

$$X \left[\frac{(K\sigma)_1}{(K\sigma)_2} \right]$$

The A.P.C.B.C./D.S. Projectile - Optimum Size.

1. Based on the Full Calibre

In this assessment the weight of the Ballistic cap is included in the weight of the body considered as perforating the target. This may not be strictly true but as its weight is a small fraction of the shot weight the error resulting is probably small. A typical form of the projectile is shown in Fig. 1.

Let	Diameter of Full calibre shot	=	d_1
	Diameter of sub calibre shot	=	d_2
	Weight of Full calibre shot	=	$W_1 = kd_1^3$
	Weight of sub calibre shot	=	$W_2 = kd_2^3$
	Weight of discard	=	W_3 (constant)
	Weight of projectile	=	$W_2 + W_3$
	Weight of charge	=	C (constant)
	Muzzle Velocity of F.C. shot	=	V_1
	Muzzle Velocity of sub shot	=	V_2

Then for constant energies as implied in assumption (a)

$$\left(W_1 + \frac{C}{2}\right) V_1^2 = \left(W_2 + W_3 + \frac{C}{2}\right) V_2^2$$

$$V_2 = V_1 \frac{1 + \frac{C}{2W_1}}{K^2 + \frac{C}{2W_2} + \frac{W_3}{W_1}} \quad \text{where } K = d_2/d_1 \quad (5)$$

$$\text{We also have, Equation (4), } X = \frac{1.656W}{d^2} (V_1 - V_2)$$

and Milne's perforation equation

$$\frac{WV^2 \sin^2 \theta}{d} = C_1 \left(\frac{X}{d}\right)^{1.43} \quad (6)$$

Applying these equations to the Full calibre and sub calibre shot

$$t_1 = \frac{1.43 \sqrt{W_1 V_1^2 \cos^2 \theta}}{\sqrt{C_1 d_1^{.87}}} \\ = \left(\frac{h}{O_1}\right)^{\frac{1}{.87}} (\cos \theta)^{\frac{1}{.87}} d_1 \left[V_1 - \frac{X}{1.656 h d_1} \right]^{\frac{1}{.87}}$$

$$t_2 = \frac{1.43 \sqrt{W_2 V_2^2 \cos^2 \theta}}{\sqrt{C_2 d_2^{.87}}} \\ = \left(\frac{h}{O_2}\right)^{\frac{1}{.87}} (\cos \theta)^{\frac{1}{.87}} d_2 \left[V_1 \left\{ \frac{1 + \frac{O_1}{2W_1}}{K + \frac{O_1}{2W_1} + \frac{W_2}{W_1}} \right\}^{\frac{1}{2}} \right. \\ \left. - \frac{m_2^2}{1.656 W_2} \right]^{\frac{1}{.87}} \\ = \left(\frac{h}{O_2}\right)^{\frac{1}{.87}} (\cos \theta)^{\frac{1}{.87}} d_2 \left[V_1 \left(\frac{1}{K+b} \right)^{\frac{1}{2}} \right. \\ \left. - \frac{m_2^2}{1.656 W_2 K} \right]^{\frac{1}{.87}}$$

Hence the ratio $R = \frac{t_2}{t_1}$ is

$$R = \frac{t_2}{t_1} = \left(\frac{O_1}{O_2}\right)^{\frac{1}{.87}} \frac{1}{f} \left[V_1 \left(\frac{K}{K+b} \right)^{\frac{1}{2}} - \frac{h}{K^{.87}} \right]^{\frac{.87}{.87}}$$

$$\text{where } a = 1 + \frac{O_1}{2W_1} \\ b = \frac{O_1}{2W_1} + \frac{W_2}{W_1} \quad (7)$$

$$K = d_2/d_1$$

$$h = \frac{m_2^2}{1.656 W_2}$$

$$f = [V_1 - h]^{\frac{1}{.87}}$$

$$l = \frac{.285h}{V_1 a^{\frac{1}{2}}} \quad (8)$$

To find the optimum R , $\frac{dR}{dK} = 0$ which from (7) gives

$$.715 - \frac{1}{2} \frac{K^2}{(K+b)} + 1 \frac{(K+b)}{K} = 0$$

It will be seen later that the effect of the third term is small, though not entirely negligible, and neglecting this, a first approximation from (8) gives

$$K_0 = .969 \sqrt{b} \quad (9)$$

Variation of the ratio $\frac{t_2}{t_1}$ with the Range X

For any ratio $K = \frac{d_2}{d_1}$ the ratio of $\frac{t_2}{t_1}$ may be determined from (7) which reduces to

$$\frac{t_2}{t_1} = \left(\frac{O_1}{O_2}\right)^{\frac{1}{.87}} \frac{1}{K^{.87}} \left[1 - \frac{1 - \left(\frac{h}{K}\right)^{\frac{1}{.87}}}{1 - K \frac{d_1}{1.656 W_1 V_1}} \right]^{\frac{.87}{.87}} \quad (10)$$

These equations will now be applied to current problems.

Example 1

20 Fr. A.P.C.B.C./D.S. - Design D2(L)6943

Diameter of gun	= 3.3 ins = d_1
Diameter of 20 Fr. sub-projectile	= 2.08 ins
M.V. of 20 Fr.	= 5020 ft/sec.
Charge weight	= 9.6 lb. = C
Weight of sub-shot and cap	= 5.2 lb. = W_2
Weight of the discard	= 2.03 lb = W_1

These particulars apply to the existing design which may be the optimum size. The following will show what the optimum size is.

The weight of a Full Calibre shot = $5.2 \left(\frac{3.3}{2.08} \right)^3 = 20.8 \text{ lb} = W_1$
 Equating Energies,

$$(5.2 + 2.03 + \frac{9.6}{2}) 5020^2 = (20.8 + \frac{9.6}{2}) V_1^2$$

Velocity of F.C. shot = $V_1 = 3440 \text{ ft./sec.}$

also

$$b = \frac{9.6}{2 \times 20.8} + \frac{2.03}{20.8} = .2308 + .0976 = .3284$$

From equation (9) the optimum value of K to first approximation is

$$K_0 = .969 \sqrt[3]{.3284} = 0.668$$

or the optimum size of sub-shot = $.668 \times 3.3 = 2.2 \text{ ins}$ and not 2.08 ins as in design D2(L)6943.

For a more accurate evaluation of K_0 equation (8) is used and commencing with a value of the order of K_0 calculated above the following tabulated method is applied. An alternative direct solution is also given in the appendix.

K	.67	.68	.69	.7	.71
K^3	.3008	.3144	.3285	.343	.3579
$K^3 + b$.6292	.6428	.6569	.6713	.6863
$\sqrt{K^3 + b}$.7932	.8018	.8105	.8193	.8284
$K^3 / K^3 + b$.4780	.4891	.5	.5109	.5215
$\sqrt{K^3 + b} / K$	1.184	1.175	1.175	1.17	1.167

$$\text{Eq. (8)} \quad X = 500 \quad +.012 \quad -.005$$

$$X = 2000 \quad +.054 \quad +.037 \quad +.02 \quad +.004 \quad -.008$$

$$\begin{aligned} \text{Also } l &= \frac{.285 \cdot d_1^3 \cdot X}{V_1 \cdot a^2 \cdot 1.656 W_1} \\ &= \frac{.285 \times 3.3^3 \cdot X}{3440 \times 1.2308^2 \times 1.656 \times 20.8} \\ &= .0000236X \end{aligned}$$

So for

$$X = 500 \text{ yds} \quad l = .0118$$

$$X = 2000 \text{ yds} \quad l = .0472$$

So the optimum for range of 500 yds is $.677 \times 3.3 = 2.23 \text{ ins}$
 for range of 2000 yds is $.703 \times 3.3 = 2.32 \text{ ins}$

It is seen, therefore, that the optimum size depends upon the range but as one size of shot only can be adopted in practice, a compromise for the above is a diameter of 2.27 ins i.e. $K = .688$.

From equation (10) the ratio of t_2/t_1 may now be calculated for this mean optimum size, and for the ranges 500 and 2000 yds.

$$\begin{aligned} \frac{t_2}{t_1} &= \left(\frac{c_1}{c_2} \right)^{1/3} \cdot \frac{1}{.688} \cdot \left[1 - \frac{1 - \left(\frac{1.2308 \times .688^3}{.688^3 + .3284} \right)^{1/3}}{1 - X \frac{3.3^3}{1.656 \times 20.8 \times 3440}} \right]^{1/3} \\ &= \left(\frac{c_1}{c_2} \right)^{1/3} \cdot 1.16 \left[1 - \frac{.0662}{1 - .00009X} \right]^{1/3} \end{aligned}$$

$$\text{For range } X = 500 \text{ yds} \quad \frac{t_2}{t_1} = 1.05 \left(\frac{c_1}{c_2} \right)^{1/3}$$

$$X = 2000 \text{ yds} \quad \frac{t_2}{t_1} = 1.055 \left(\frac{c_1}{c_2} \right)^{1/3}$$

So at 500 yds the sub-shot is 5% better than the F.C. projectile and at 2000 yds the sub shot is 3 1/2% better than the F.C. projectile assuming assumption (e) applies i.e. $c_1 = c_2$

Example 2105 mm. A.P.C.A.C./D.S. - B2(L) 6816

Diameter of gun = 105 mm. = 4.134 ins.

This shot is a scale-up of the 20 Pr. sub-shot 2.08 ins. diameter and weight 5.2 lb.

Charge weight = 16.5 lb.

Weight of discard = 4.22 lb.

$$\text{Weight of F.C. shot} = 5.2 \left(\frac{4.134}{2.08} \right)^3 = 41.1 \text{ lb} = W_1$$

For the estimation of the M.V. of the F.C. shot the only information available for a sub shot, and the charge used above (16.5 lb) is a sub-shot and discard weight of 19 lb having an M.V. of 4400 ft/sec.

Based on this, the velocity of the F.C. shot is given by

$$\left(19 + \frac{16.5}{2} \right) 4400^2 = \left(41.1 + \frac{16.5}{2} \right) V_1^2$$

$$V_1 = 3270 \text{ ft/sec.}$$

$$h = \frac{16.5}{2 \times 41.1} + \frac{4.22}{41.1} = .2 + 103 = .303$$

And the optimum size to the first approximation is

$$K_0 = .969 \sqrt[3]{.303} = .651$$

or the optimum size = .651 x 4.134 = 2.69 ins.

Again applying the tabular method to obtain more accurate values

K	.65	.66	.67	.68
K ³	.2746	.2875	.3001	.3144
K ³ +b	.5776	.5905	.6038	.6174
$\sqrt{K^3+b}$.76	.7684	.777	.7858
K ³ /K ³ +b	.4754	.4869	.498	.5093
$\sqrt{K^3+b}/K$	1.169	1.164	1.16	1.155
Eq. (B)	X=500	+ .013	- .004	
	X=2000	+ .046	+ .03	+ .014
			- .005	

$$t = \frac{285}{3270 \times 1.2^2} \cdot \frac{4.134^2 X}{1.656 \times 41.1} = .00002$$

$$\text{For } X = 500 \text{ yds } t = .01$$

$$X = 2000 \text{ yds } t = .04$$

So the optimum size for the range of 500 yards = .658 x 4.134 = 2.72 ins

for the range of 2000 yds = .678 x 4.134 = 2.81 ins

or a mean of 2.76 ins or K = .67 and the ratio

$$\frac{t}{t_0} = \left(\frac{C_1}{C_0} \right)^{\frac{1}{2}} \frac{1}{.67} \left[1 - \frac{1 - \frac{(1.2 \times .67^2)}{.67^2 + .303}}{X \cdot 4.134^2} \right]^{\frac{1}{2}}$$

$$= \left(\frac{C_1}{C_0} \right)^{\frac{1}{2}} 1.17 \left[1 - \frac{.07}{1 - .000076X} \right]^{\frac{1}{2}}$$

$$\text{For } X = 500 \text{ yds} \quad \frac{t_2}{t_1} = 1.05 \left(\frac{C_1}{C_2} \right)^{\frac{1}{2}} \\ X = 2000 \text{ yds} \quad \frac{t_2}{t_1} = 1.057 \left(\frac{C_1}{C_2} \right)^{\frac{1}{2}}$$

So at 500 yds the sub-shot is 5% better than the F.C. projectile and at 2000 yds the sub-shot is 3% better than the F.C. projectile.

First Summary.

- Equation (9) shows, to a first approximation, the optimum size relative to the F.C. size is given by

$$K_0 = .969 \sqrt{b}$$

whence b depends upon the charge weight, the discard weight and weight of the F.C. shot. A closer value is obtained by use of equation (8) but the examples show more clearly that the optimum size varies as the range varies.

- The examples also show that a rough rule for the optimum size is 2/3 of F.C. size.
- Equation (10) gives the ratio of plate thickness capable of being perforated by the sub-shot and F.C., and shows that as the range increases this ratio decreases slightly.
- Equations (7) and (8) show that the optimum size is neither affected by the angle of attack θ when this is constant for both the subshot and F.C. shot, nor by any difference in the $\log_{10} C$.

Differences in the values of $\log C$ would however affect the perforation ratio t_2/t_1 , as shown by equation (10) if such differences existed. S.A.B. however consider that where similar shape shot are used $\log_{10} C$ is reasonably constant and that the relationship between $\log_{10} C$ and t/d given in Proc. 26399 - $\log_{10} C = a + b \left(\frac{t}{d} - 1 \right)$ - is doubtful for general use.

- In order to reduce any argument as to the effect of possible differences between $\log_{10} C$, and the weights of discards (noting that in fact the F.C. shot does not carry a discard) the following examples approaches the problem as the designer would do. That is he first estimates the weights and obtains the ballistics for a size of shot of the order of the optimum size and then with this data proceeds to determine the optimum size. By so doing the $\log_{10} C$ value of discard weight is less liable to vary with slight differences in shot size.

Alternative Method based upon Designer's Preliminary estimates.

In the following, suffix 1 applies to the size of the designer's first assessment and suffix 2 to the optimum size shot.

	<u>Tentative Design of Sub-cal Projectile</u>	<u>Required Optimum Size</u>
Weight of sub-shot	$= W_1 = kd_1^3$	$= W_2 = kd_2^3$
Discard weight	$= W_d$	$= W_d$
Charge weight	$= C$	$= C$
M.V.	$= V_1$	$= V_2$

K is again the ration $\frac{d_2}{d_1}$ but related to the tentative design.

$$\text{Equating Energies} \quad (W_1 + W_d + \frac{C}{2}) V_1^2 = (W_2 + W_d + \frac{C}{2}) V_2^2 \\ V_2 = V_1 \left(\frac{W_1 + W_d + \frac{C}{2}}{W_2 + W_d + \frac{C}{2}} \right)^{\frac{1}{2}} = V_1 \left(\frac{1}{K^3 + b} \right)^{\frac{1}{2}}$$

$$\begin{aligned} \text{From (4)} \quad X &= 1.656 \frac{W_1}{d_1} (V_1 - V_{1x}) & X &= 1.656 \frac{W_2}{d_2} (V_2 - V_{2x}) \\ V_{1x} &= V_1 - \frac{d_1 X}{1.656 W_1} & V_{2x} &= V_2 - \frac{d_2 X}{1.656 W_2} \\ & & &= V_2 - \frac{W_1}{1.656 W_2} \cdot \frac{1}{K} \\ \text{From (6)} \quad t_1 &= \frac{X}{C_1 d_1} \sqrt{\frac{W_1 V_1^2 \cos^2 \theta}{1.656 W_1}} & t_2 &= \frac{X}{C_2 d_2} \sqrt{\frac{W_2 V_2^2 \cos^2 \theta}{1.656 W_2}} \end{aligned}$$

and the ratio R reduces to

$$R = \frac{t_2}{t_1} = \left(\frac{C_1}{C_2}\right)^{\frac{1}{2}} \frac{1}{K} \left(V_1 a^{\frac{1}{2}} \frac{1}{K+b} - \frac{h}{K} \right)^{\frac{1}{2}} \quad (11)$$

which is the same form as (10) but the values are now

$$\begin{aligned} a &= 1 + \frac{W_2}{W_1} + \frac{C}{2W_1} & h &= \frac{X d_1}{1.656 W_2} \\ b &= \frac{W_2}{W_1} + \frac{C}{2W_1} & r &= (V_1 - h)^{\frac{1}{2}} \\ K &= d_2/d_1 & l &= .285W/V_1 a^{\frac{1}{2}} \end{aligned}$$

Again the optimum size is given by

$$.715 - \frac{1}{2} \frac{h}{K+b} + l \frac{(K+b)^{\frac{1}{2}}}{K} = 0 \quad (12)$$

and to a first approximation

$$K = .969 \sqrt{b} \quad (13)$$

and the variation of $\frac{t_2}{t_1}$ with range X by

$$\frac{t_2}{t_1} = \left(\frac{C_1}{C_2}\right)^{\frac{1}{2}} \frac{1}{K} \left[1 - \frac{1 - \left(\frac{h}{K+b}\right)^{\frac{1}{2}}}{1 - \frac{h}{K}} \right]^{\frac{1}{2}} \quad (14)$$

Equation (12), (13), (14) are similar to (10), (9), (10) but now related to the Designer's tentative size estimate.

This alternative method is now applied to the problems of examples 1 and 2.

Example 3

This is the problem of example 1 but now

Tentative shot diameter	= 2.08 ins = d_1
Weight of shot and cap	= 5.2 lb = W_1
Weight of discard	= 2.03 lb = W_2
Weight of charge	= 9.6 lb = C
M.V. of shot	= 5020 ft/sec. = V_1

For a first approximation, equation (13) gives

$$b = \frac{9.6}{25.2} + \frac{2.03}{5.2} = .923 + .3885 = 1.3115$$

$$a = 1 + b = 2.3115$$

$$K = .969 \sqrt{1.3115} = 1.06 \text{ or optimum size} = 1.06 \times 2.08 = 2.2 \text{ ins.}$$

now using (13) to obtain more accurate values for ranges of 500 and 2000 yds

K	1.06	1.07	1.08	1.10	1.12	$l = \frac{.285 \times 2.08^3 X}{1.656 \times 5.2 \times 5020 \times 2.3115^2}$ $= .0000187X$		
K ²	1.191	1.225	1.261	1.331	1.405			
K ³ + b	2.502	2.537	2.57	2.642	2.716			
$\sqrt{K^2 + b}$	1.5417	1.593	1.603	1.625	1.648			
K ² /K ² +b	.476	.4828	.49	.5037	.517			
$\sqrt{K^2 + b}/K$	1.492	1.488	1.485	1.477	1.471			
Eq (12)	X=500	+.015	+.0046	-.0077		For X = 500	l = .0093	
	X=2000	+.056	+.046	+.035	+.016	-.0035	X = 2000	l = .0372

So the optimum size for range of 500 yds = 1.075 x 2.08 = 2.24 ins.

for range of 2000 yds = 1.1175 x 2.08 = 2.32 ins.

These values are in good agreement with example 1.

The practical optimum is 2.27 ins as before but γ now related to the tentative design size is 1.091.

From 11.

$$\frac{t_2}{t_1} = \left(\frac{c_1}{c_2}\right)^{\frac{1}{3}} \frac{1}{1.091} \left[1 - \frac{1 - \left(\frac{2.3115 \times 1.091^3}{1.091^3 + 1.656 \times 5.2 \times 5020}\right)^{\frac{1}{3}}}{1 - \frac{X \cdot 2.08}{1.656 \times 5.2 \times 5020}} \right]^{\frac{2}{3}}$$

$$= \left(\frac{c_1}{c_2}\right)^{\frac{1}{3}} \cdot 966 \left[1 - \frac{-0.0268}{1 - 0.0001X} \right]^{\frac{2}{3}}$$

For X = 500 yds

$$\frac{t_2}{t_1} = 1.004 \left(\frac{c_1}{c_2}\right)^{\frac{1}{3}}$$

X = 2000 yds

$$\frac{t_2}{t_1} = 1.011 \left(\frac{c_1}{c_2}\right)^{\frac{1}{3}}$$

As the tentative design size of 2.08 ins is close to that of the optimum size of 2.27 ins, it is now more reasonable than before to consider that c_1 and c_2 (usually given as $\log_{10} c$ in the perforation formula) are constant, and W_s , the discard weight, does not vary seriously.

It is also to be noted that the thickness of plate perforated by the optimum size shot of 2.27 diameter compared with that of 2.08 diameter is 0.4% and 1.1% better, that is, for this difference in diameters, the improvement is small.

Example 4.

This is the problem of example 2.

As before, the 20 Pr. is taken, but now as the tentative design size.

Thus we have

Decimeter of sub-shot	= 2.08 ins = d_1
Weight of 20 Pr. shot and cap	= 5.2 lb = W_1
Weight discard	= 4.22 lb = W_2
Weight of charge	= 16.5 lb = C

The velocity for this tentative design is also based on the projectile referred to in example 2 viz. weight 19 lbs with 16.5 lb charge gave a velocity 1100 ft/sec.

So M.V. of the above 20 Pr. projectile is given by

$$\left(19 + \frac{16.5}{2}\right) 4400^2 = \left(5.2 + 4.22 + \frac{16.5}{2}\right) V_1^2$$

$$V_1 = 5464$$

$$b = \frac{16.5}{2 \times 5.2} + \frac{4.22}{5.2} = 1.586 + .812 = 2.398$$

$$a = 1 + b = 3.398$$

For first approximation $K_0 = .969 \sqrt[3]{2.398} = 1.297$ from (1).

$$\text{or optimum size} = 1.297 \times 2.08 = 2.7 \text{ ins.}$$

Using eq. 12 to obtain more accurate values, we have

K	1.3	1.31	1.32	1.34	1.36	$l = \frac{.285 \times 2.08^3}{5464 \times 3.398 + 1.656 \times 5.2}$ $= .0000144X$	
K^2	2.197	3.248	2.3	2.406	2.515		
$\frac{K^2+b}{K}$	4.595	4.646	4.698	4.804	4.914		
$\sqrt{K^2+b}$	2.144	2.158	2.168	2.192	2.217		
$\frac{K^2/K^2+b}{K}$.475	.4839	.4896	.5	.511		
$\sqrt{K^2+b}/K$	1.649	1.647	1.642	1.636	1.63	For X = 500	l = .0072
Eq. (12)	X = 500 +.014	+ .001	- .008			X = 2000	l = .0288
	X = 2000 +.05	+ .037	+ .029	+ .012	- .0046		

So optimum size for range 500 yds = 1.315 x 2.08 = 2.73

For range 2000 yds = 1.355 x 2.08 = 2.82

or a practical mean of 2.77 which is in good agreement with example 2.

$$K_0 \text{ is now } \frac{2.77}{2.08} = 1.331$$

From (1),

$$\frac{t_2}{t_1} = \left(\frac{c_1}{c_2}\right) \left(\frac{r_1}{r_2}\right)^{1/3} \frac{1}{1.331^{1/3}} \left[1 - \frac{1 - \left(\frac{3.398 \times 1.331^3}{1.331^3 + 2.398}\right)^{1/3}}{1 - \frac{1.656 \times 5.2 \times 2.08^2}{1.656 \times 5.2 \times 2.08^2}} \right]^{1/3}$$

$$= \left(\frac{c_1}{c_2}\right) \left(\frac{r_1}{r_2}\right)^{1/3} \times .872 \left[1 - \frac{-.125}{1 - .000093X} \right]^{1/3}$$

For X = 500

$$\frac{t_2}{t_1} = 1.035 \left(\frac{c_1}{c_2}\right) \left(\frac{r_1}{r_2}\right)^{1/3}$$

X = 2000

$$\frac{t_2}{t_1} = 1.063 \left(\frac{c_1}{c_2}\right) \left(\frac{r_1}{r_2}\right)^{1/3}$$

So at 500 yds the optimum shot is 3% better than the tentative design size of 2.09 ins and at 2000 yds it is 6% better.

Second Summary

The results obtained by the alternative method, which relates to the Designers first design, are in agreement with the optimum size determined in relation to the F.C. size.

It is, however, to be noted that whereas, compared with the F.C. projectile, the ratios t_2/t_1 decrease with increase of range, the ratio, compared with the Designers tentative size, which in both examples (3) and (4) were smaller than the optimum sizes determined, increases with increase of range.

The A.P.D.S. Projectile - Optimum Size.

As for the A.P.C.B.C./D.S. projectile, the first object in the following is to determine the optimum size related to the F.C. size, then to obtain the equations related to the Designer's tentative design. This type of D.S. projectile comprises a shot of dense material, a ballistic cap, a sheath which holds shot and cap together, and a discard.

Relationship to F.C. Size.

Typical assemblies of the F.C. and D.S. projectile are shown by Figs. 2. Following the previous method we have:-

<u>Full Calibre Projectile</u>		<u>Discarding Sabot Projectile</u>	
Core weight	= $W_1 = k_1 d_1^3$	Core weight	= $W_7 = k_1 d_2^3$
Cap weight	= $W_2 = k_2 W_1 = k_2 k_1 d_1^3$	Cap weight	= $W_8 = k_2 W_7 = k_2 k_1 d_2^3$
Sheath weight	= $W_4 = k_4 W_1 = k_4 k_1 d_1^3$	Sheath weight	= $W_9 = k_4 W_7 = k_4 k_1 d_2^3$
Charge weight	= C	Charge weight	= C
M.V.	= V_F	M.V.	= V_S
Sheath thickness	= $(D-d_1)/2$	Sheath thickness	= $\frac{(D-d_2)}{2} \cdot \frac{d_2}{d_1}$
Total weight	= $W = W_1 + W_2 + W_4$	Discard weight	= W_8
Diameter of F.C.	= D	Diameter of core	= d_2
Diameter of core	= d_1	Let K	= d_2/d_1
Let Z -	= d_1/D	then d_2/d_1	= $\frac{K}{Z}$

Equating energies:-

$$(W_1 + W_2 + W_4 + \frac{C}{2}) V_F^2 = (W_7 + W_8 + W_9 + W_8 + \frac{C}{2}) V_S^2$$

$$V_S = V_F \left[\frac{a}{nk^2 + b} \right]^{\frac{1}{2}} = V_F \left[\frac{n}{K^2 + m} \right]^{\frac{1}{2}}$$

where

$$a = 1 + k_2 + k_4 + \frac{C}{2W_1}$$

$$b = \frac{W_2}{W_1} + \frac{C}{2W_1}$$

$$n = \frac{(1+k_2+k_4)/Z^3}{W_1 Z^3} = \frac{W_1 Z^3}{W_1 Z^3}$$

$$m = a/n = \left(\frac{W}{W_1} + \frac{C}{2W_1} \right) \frac{W_1 Z^3}{W_1 Z^3} = Z^3 \left(1 + \frac{C}{2W} \right)$$

$$k = b/n = \left(\frac{W_2}{W_1} + \frac{C}{2W_1} \right) \frac{W_1 Z^3}{W_1 Z^3} = Z^3 \left(\frac{W_2}{W_1} + \frac{C}{2W} \right)$$

Range, and Velocity at Target

The shape of the D.S. Projectile in flight is the same as the A.P.C.B.C. shot considered previously and hence the relationship given by equation (4) applies

$$X = 1.656 \frac{W}{d^3} (V - V_D)$$

The target velocity for the F.C. and D.S. Projectile are therefore

$$V_{Fx} = V_F - \frac{X D^3}{1.656(W_1 + W_2 + W_4)}$$

$$V_{Sx} = V_S - \frac{X \left[d_2 + \frac{d_2(D-d_2)}{d_1} \right]^3}{1.656(W_7 + W_8 + W_9)}$$

$$= V_F - \frac{X}{1.656 Z^3 k_1 \frac{W}{W_1}}$$

$$= V_S \left(\frac{n}{K^2 + m} \right)^{\frac{1}{2}} - \frac{X}{1.656 Z^3 k_1 D \cdot \frac{W}{W_1} \cdot K}$$

Thickness of Plate Perforated

$$t_p = \frac{1.44 \sqrt{(W_1 + W_2) V_{SX}^2 \cos^2 \theta}}{\sqrt{C_p d_1^{2.87}}} \quad t_s = \frac{1.44 \sqrt{(W_1 + W_2) V_{SX}^2 \cos^2 \theta}}{C_3 d_2^{2.87}}$$

$$\begin{aligned} \text{and } \frac{t_s}{t_p} &= \frac{1.44 \sqrt{(W_1 + W_2) \left(\frac{V_{SX}}{V_{PX}}\right)^2 \frac{C_p}{C_3} \left(\frac{d_1}{d_2}\right)^{2.87}}}{\sqrt{(W_1 + W_2) \left(\frac{V_{SX}}{V_{PX}}\right)^2 \frac{C_p}{C_3} \left(\frac{d_1}{d_2}\right)^{2.87}}} \\ &= \frac{1.44 \sqrt{\left(\frac{d_2}{d_1}\right) \left(\frac{d_1}{d_2}\right)^{2.87} \cdot \frac{C_p}{C_3} \cdot \frac{1}{r} \left[V_p \left(\frac{s}{K+m}\right)^{\frac{1}{2}} - \frac{KW}{1.656 Z^2 k_1 DW} \right]^2}}{\sqrt{(W_1 + W_2) \left(\frac{V_{SX}}{V_{PX}}\right)^2 \frac{C_p}{C_3} \left(\frac{d_1}{d_2}\right)^{2.87}}} \\ &= \left(\frac{C_p}{C_3}\right)^{\frac{1}{2.87}} \frac{1}{Z} \left[V_p s^{\frac{1}{2}} \cdot \left(\frac{K}{K+m}\right)^{\frac{1}{2}} - \frac{h}{K} \right]^{\frac{2}{2.87}} \end{aligned} \quad (15)$$

which is similar to equation (8)

$$\begin{aligned} \text{where } r &= \left[V_p - \frac{KW}{1.656 k_1 Z^2 DW} \right]^{\frac{2}{2.87}} = \left(V_p - \frac{h}{Z} \right) \\ h &= \frac{KDZ}{1.656W} \end{aligned}$$

Differentiating (15), and equating to zero as before, the optimum size is given by

$$.715 - \frac{1}{2} \frac{K}{K+m} + 1 \frac{(K+m)^{\frac{1}{2}}}{K} = 0 \quad (16)$$

$$\text{where } = \frac{.285h}{V_p s^{\frac{1}{2}}}$$

The first approximation to the optimum size is again obtained by neglecting the third value of (16) giving

$$\frac{d_2}{D} = K_0 = .969 \sqrt{m} = .969 \sqrt{\frac{1}{W} (W_1 + W_2)} \quad (17)$$

With this as a starting value, the tabular method previously used can be applied to (16) to determine more accurate optimum sizes relating to varying ranges. Then the rates of plate thickness, perforated by this optimum size, to that by the F.C. can be calculated from (15) which reduces to the form

$$\frac{t_s}{t_p} = \left(\frac{C_p}{C_3}\right)^{\frac{1}{2.87}} \cdot \frac{1}{Z} \dots \left[\frac{1}{Z} - \frac{1}{Z} \frac{\left(\frac{K}{K+m}\right)^{\frac{1}{2}}}{1 - \frac{KDZ}{1.656WV_p}} \right]^{\frac{2}{2.87}} \quad (18)$$

now (17) is the same as (9) with the inclusion of the ratio Z. From current designs the value of Z is of the order .77. The rough rule for A.P.C.B.C./D.S. shot is $\frac{1}{3}$ F.C. hence the rough rule for A.P./D.S. becomes

$$\frac{2}{3} \times \text{F.C.} \times .77 = \frac{1}{2} \text{F.C.}$$

Alternative Solution based on Designers Tentative Design

The designers A.P./D.S. tentative core size can as shown above be taken as $\frac{1}{3}$ F.C. size. Proceeding as before, we have (see fig. 3)

	<u>Tentative Design</u>	<u>Alternative</u>
Core weight	$= W_7 = k_1 d_3^3$	$W_8 = k_1 d_3^3$
Cap weight	$= W_9 = k_2 W_7 = k_2 k_1 d_3^3$	$W_9 = k_2 W_8 = k_2 k_1 d_3^3$
Sheath weight	$= W_{10} = k_3 W_7 = k_3 k_1 d_3^3$	$W_{10} = k_3 W_8 = k_3 k_1 d_3^3$

M.V.	= V_T	V_A
Charge	= C_T	C_A
Sheath thickness	= t_{ST}	$t_{SA} = \frac{C_A}{W_A}$
Discard weight	= W_D	W_D
Diameter of gun	= D	D
Total weight of projectile	= $W_T + W_S + W_C + W_D = W_T$	$W_C + W_S + W_{10} + W_D = W_A$
Diameter of sheath	= d_s	

$$K = \frac{d_p}{d_s}$$

Equating Energies we get

$$V_A = V_T \left(\frac{K}{K+m} \right)^{\frac{1}{2}}$$

where

$$m = \frac{1}{W_T} (W_T + \frac{C}{2})$$

$$m = \frac{W_D + \frac{C}{2}}{W_T - W_D}$$

Target Velocities

$$V_{Tx} = V_T - \frac{X(d_s + 2t_T)^2}{1.656(W_T + W_S + W_C)}$$

$$V_{Ax} = V_A - \frac{X \left[d_s + 2t_T \cdot \frac{d_s}{d_s} \right]^2}{1.656(W_C + W_S + W_{10})}$$

$$= V_T - p$$

$$= V_T \left(\frac{K}{K+m} \right)^{\frac{1}{2}} - \frac{p}{K}$$

where

$$p = \frac{X d_s^2}{1.656(W_T - W_D)}$$

$$t_T = \frac{1.43 \sqrt{(W_T + W_D) V_T^2 \cos^2 \theta}}{\sqrt{C_T d_s^{2.87}}}$$

$$t_A = \frac{1.43 \sqrt{(W_C + W_S) V_{Ax}^2 \cos^2 \theta}}{\sqrt{C_A d_s^{2.87}}}$$

$$\frac{t_A}{t_T} = \frac{1.43 \sqrt{(W_C + W_S) \left(\frac{V_{Ax}}{V_T} \right) \left(\frac{C_T}{C_A} \right) \left(\frac{d_s}{d_s} \right)^{2.87}}}{\sqrt{(W_T + W_D) \left(\frac{V_T}{V_T} \right) \left(\frac{C_T}{C_A} \right) \left(\frac{d_s}{d_s} \right)^{2.87}}}$$

$$= \frac{1.43 \sqrt{C_T}}{\sqrt{C_A (V_T - p)^2}} \left\{ V_T \left[\frac{K}{K+m} \right]^{\frac{1}{2}} - \frac{p}{K} \right\}^{\frac{1}{2.87}} \quad (19)$$

The optimum size is given by

$$.715 - \frac{1}{2} \frac{K^2}{(K+m)} + 1 \frac{(K+m)^{\frac{1}{2}}}{K} = 0 \quad (20)$$

where

$$1 = \frac{1.285 p}{V_T^2}$$

and the first approximation by

$$K_0 = .969 \sqrt{m} = .969 \sqrt{\frac{C}{2 + W_D}} \quad (21)$$

Variation of ratio t_A/t_T with Range

As before, equation (19) reduces to

$$\frac{t_A}{t_T} = \left(\frac{C_T}{C_A} \right)^{\frac{1}{2.87}} \frac{1}{K+m} \left[1 - \frac{1 - \left(\frac{K}{K+m} \right)^{\frac{1}{2}}}{1 - \frac{X d_s}{1.656(W_T - W_D) V_T}} \right]^{\frac{1}{2.87}} \quad (22)$$

Conclusions

It is shown that rough rules for the optimum size of A.P.C.B.C./D.S. shot and A.P./D.S. cores are $2/3$ P.C. and $1/2$ P.C. respectively.

A closer value is given by the typical equation

$$\text{optimum size ratio } K = .969 A^{2/3} B$$

where A and B relate to functions of dimensions and weights of either the P.C. projectile or Designer's tentative design.

It is also shown that the true optimum size is dependent on the target range and is therefore not constant for all ranges. Nevertheless for practical reasons the size to be selected must be common for all practical ranges and therefore a mean value of the extremes calculated.

The examples show that, though the optimum size shot gives the maximum perforation, the rate of change of thickness perforated, with variation of size of shot around the optimum, is small.

For this reason, and especially when economy in cost and material is necessary it may be considered sufficient to design to a shot size slightly less than the optimum.

APPENDIX

An alternative solution to solving the equations (8), (12), (16) and (20) all of which are of the form

$$.715 - \frac{3}{2} \frac{K^2}{K^2+b} + \frac{(K^2+b)^{\frac{3}{2}}}{K} = 0 \quad (a)$$

and having to a first approximation the solution

$$K_0 = .969 \sqrt[3]{b} \quad (b)$$

may be obtained by use of the Taylor Theorem. This method can replace the tabular method used in the paper.

The Taylor expansion is given by

$$f(x+h) = f(x) + hf'(x) + \frac{h^2}{2} f''(x) = 0$$

taking the first two terms we have

$$h = - \frac{f(x)}{f'(x)}$$

From the equations (a) and (b) above we have

$$f(K_0) = .715 - \frac{3}{2} \frac{.969^2 b}{(.969^2 b + b)} + \frac{(.969^2 b + b)^{\frac{3}{2}}}{.969 b^{\frac{1}{3}}} = 1.4262 \text{ } b^{\frac{1}{3}}$$

$$f'(K) = -\frac{9}{2} \frac{K^2}{(K^2+b)^2} + \left[\frac{3K}{2(K^2+b)^{\frac{3}{2}}} - \frac{(K^2+b)^{\frac{1}{2}}}{K^2} \right]$$

and

$$f'(K_0) = -\frac{9}{2} \frac{.969^2 b^{\frac{2}{3}}}{(.969^2 b + b)^2} + \left[\frac{3}{2} \frac{.969^2 b^{\frac{1}{3}}}{(.969^2 b + b)^{\frac{3}{2}}} - \frac{(.969^2 b + b)^{\frac{1}{2}}}{.969 b^{\frac{1}{3}}} \right]$$

$$= - \left[\frac{1.158}{b^{\frac{1}{3}}} + .3745 \frac{1}{b^{\frac{1}{3}}} \right]$$

Hence the solution becomes

$$.969 b^{\frac{1}{3}} + \frac{1.4262 \text{ } b^{\frac{1}{3}}}{\left(\frac{1.158}{b^{\frac{1}{3}}} + .3745 \frac{1}{b^{\frac{1}{3}}} \right)}$$

$$= \left[.969 + \frac{1.4262 \text{ } b^{\frac{1}{3}}}{1.158 + .3745 \text{ } b^{\frac{1}{3}}} \right] b^{\frac{1}{3}}$$

$$= \left[.969 + 1.2316 \text{ } b^{\frac{1}{3}} \right] b^{\frac{1}{3}} \text{ with sufficient accuracy} \quad (c)$$

For example, applying this to example 1 and for the range $X = 2000$ yds. we had $b = .3284$ $l = .0472$

$$\text{From (c) above - Opt. size ratio} = .3284^{\frac{1}{3}} (.969 + 1.2316 \times .0472 \times .3284^{\frac{1}{3}})$$

$$= .6899 (.969 + .0483) = .7027$$

$$\text{or optimum size} = 3.3 \times .7027 = 2.32 \text{ ins. as before}$$

For example 3 we had $b = 1.3115$, and $l = .0372$ at 2000 yds range

$$\text{then optimum size ratio} = 1.3115^{\frac{1}{3}} (.969 + 1.2316 \times .0372 \times 1.3115^{\frac{1}{3}})$$

$$= 1.0946 (.969 + .048) = 1.113$$

$$\text{Optimum size} = 2.08 \times 1.113 = 2.32 \text{ ins. as before.}$$

SECRET

FIG. 1.

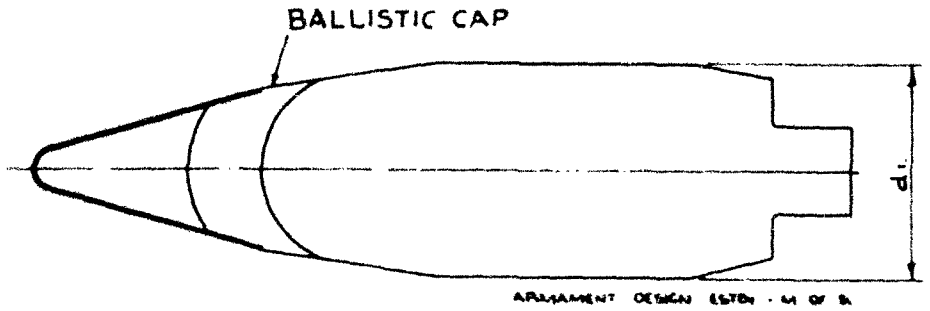

A PC BC - FULL CALIBRE SHOT.

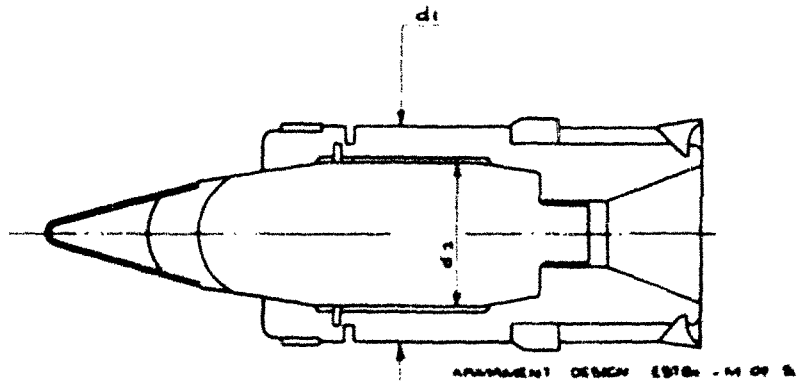

A PC BC./D.S PROJECTILE.

SECRET

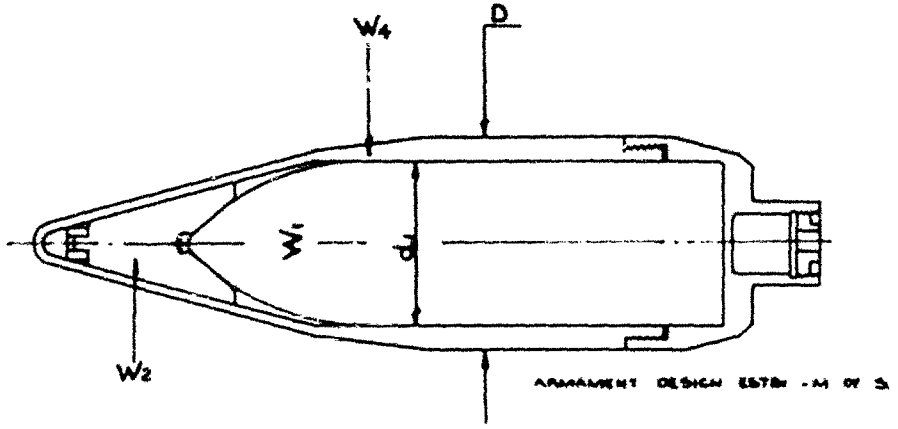

AP - FULL CALIBRE

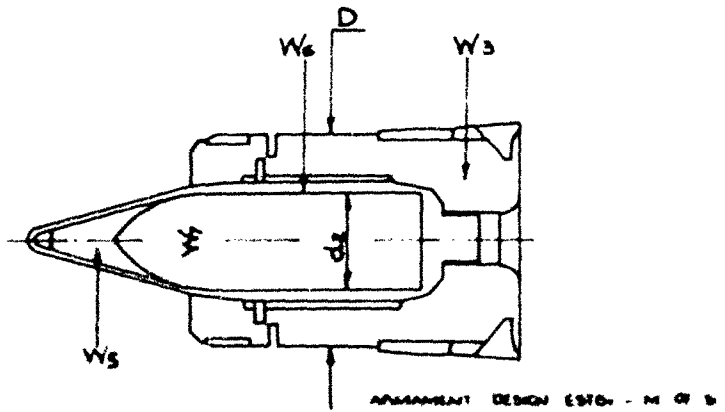

AP/D.S. - PROJECTILE

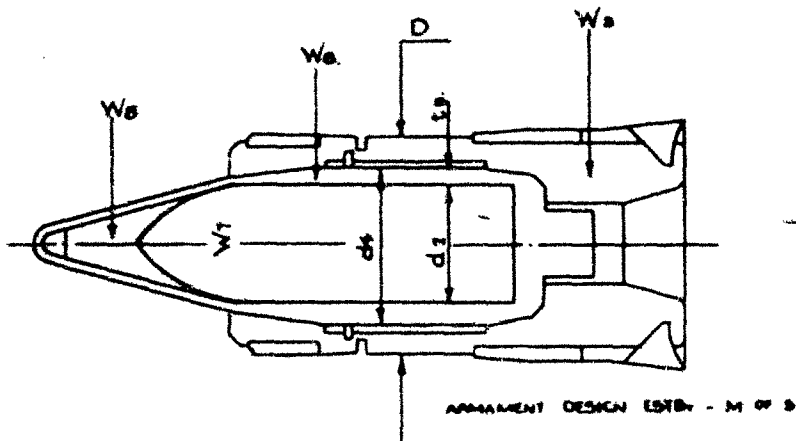

A P/D.S. TENTATIVE DESIGN.

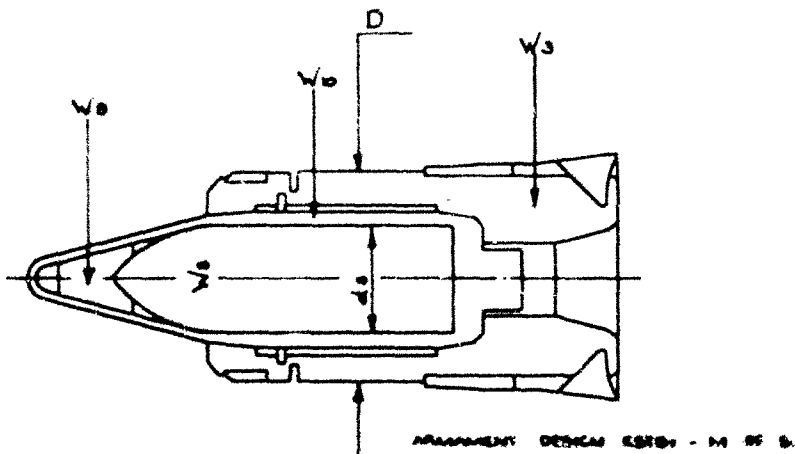

A P/D.S. OPTIMUM SIZE.



*Information Centre
Knowledge Services*
[dstl] Porton Down,
Salisbury
Wiltshire
SP4 0JQ
22060-6218
Tel: 01980-613753
Fax 01980-613970

Defense Technical Information Center (DTIC)
8725 John J. Kingman Road, Suit 0944
Fort Belvoir, VA 22060-6218
U.S.A.

AD#: AD011686

Date of Search: 27 October 2008

Record Summary: DEFE 15/327

Title: The Determination of the Optimum Size of A.P.C.B.C./D.S. Shot and of the Tungsten Core of A.P./D.S. Projectile for Maximum Perforation of Armoured Plate
Availability Open Document, Open Description, Normal Closure before FOI Act: 30 years
Former reference (Department) Technical Report No. 9/52
Held by The National Archives, Kew

This document is now available at the National Archives, Kew, Surrey, United Kingdom.

DTIC has checked the National Archives Catalogue website (<http://www.nationalarchives.gov.uk>) and found the document is available and releasable to the public.

Access to UK public records is governed by statute, namely the Public Records Act, 1958, and the Public Records Act, 1967.

The document has been released under the 30 year rule.

(The vast majority of records selected for permanent preservation are made available to the public when they are 30 years old. This is commonly referred to as the 30 year rule and was established by the Public Records Act of 1967).

This document may be treated as UNLIMITED.