

Technical Report 3

**MEASUREMENT BY TIMED SPARK SHADOWGRAPHS
OF SHOCK VELOCITIES IN THE SHOCK TUBE**

by

HERBERT L. HOOVER

Submitted by
R. J. Emrich
1 July 1953

Project NR 061-063
Contract N7onr 39302
Office of Naval Research

MEASUREMENT BY TIMED SPARK
SHADOW GRAPHS OF SHOCK VELOCITIES

IN THE SHOCK TUBE

by

Herbert L. Hoover

Technical Report 3
Project NR 061-063
issued under contract N7 onr 39302
between the Office of Naval Research
and the Institute of Research,
Lehigh University

This report which comprises the M.S. thesis of the author describes research carried out in the Physics Department of Lehigh University from June 1950 to June 1953. The work, jointly supported by ONR and the Physics Department, is part of a program of study of transient flow of gases in a tube. The measurements reported herein were performed to extend those reported in Technical Report 2 which appeared in the March 1953 issue of the Journal of Applied Physics.

R. J. Emrich
C. W. Curtis

Abstract

Using a rectangular shock tube with glass walls, shock propagation near the diaphragm has been studied quantitatively by means of double spark shadowgraphs. The cross-section of the tube had dimensions of 0.64 and 7.6 cm. For positions between 100 and 250 hydraulic radii from the diaphragm, shock velocities were measured by timing the interval between the sparks. Within this region the shock velocity is greatest at the position nearest the diaphragm, but not as large as predicted by ideal theory.

INTRODUCTION

The velocities of shock travelling in a shock tube of rectangular cross section .64 by 7.6 cm were measured in a series of experiments to determine the attenuation with travel^{1/}. The shock velocity decreased continuously with travel over the range studied by these measurements, which were made by timing the arrival of the shock at optical detection stations located at 50 cm intervals along the tube. These tests however did not include measurements very near to the diaphragm. The tests to be described studied the shock propagation within the 75 cm of channel (250 hydraulic radii) nearest the diaphragm.

^{1/} R. J. Emrich and C. W. Curtis, Journ. Appl. Physics
24, 360 (1953)

These measurements of shock velocity near the diaphragm employed a section of channel with plate glass walls. Spark shadowgraphs of the shock within the channel determined its position and configuration at two successive times, and these times at which the sparks flashed, together with the time at which the shock arrived at an optical detection station at the end of the glass channel, were recorded on a chronograph.

The configuration of the shock within the 30 cm nearest the diaphragm differs markedly from a plane shock. In Figure 1, tracings of shadowgraphs^{2/} indicate the way in which the initially curved shock undergoes a series of Mach reflections until a nearly plane shock is formed. Since different parts of the shock front, e.g. the center and the part adjacent to the wall, move with different velocities during this stage of propagation, velocity measurements were made only in the interval from 30 cm to 75 cm from the diaphragm.

The study of shock propagation near the diaphragm by timed spark shadowgraphs was proposed by C. W. Curtis. W. R. Smith and R. A. Shunk constructed apparatus and performed a series of preliminary tests of the type described herein, and their contributions to this work are gratefully acknowledged. R. M. Wilcox also assisted in the construction of electronic equipment.

^{2/} These shadowgraphs were made by R. A. Shunk.

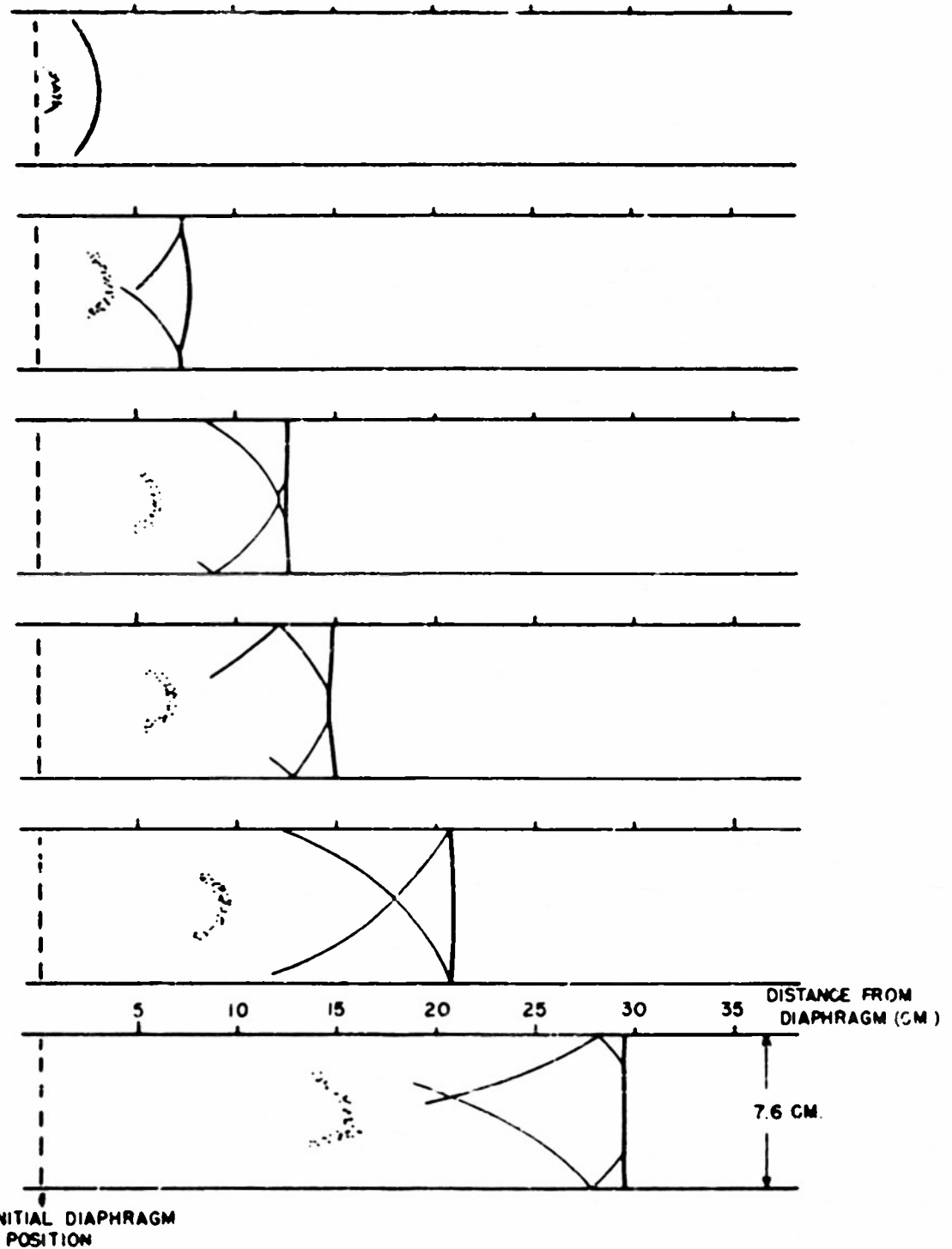

FIG. 1 SHOCK FORMATION IN SHOCK TUBE $P_c/P_0 = 3.02$
 Tracings from spark photographs

APPARATUS AND METHOD OF MEASUREMENT

Figure 2 shows the relative positioning of the apparatus except for the pressure and electronics equipment. Figure 3, which is a block diagram showing the sequence of operations for obtaining a record, indicates the functions of various units and their interconnections.

Shock Tube. The chamber of the shock tube was constructed of 3/4" by 6" duralumin plates separated by 1/4" Lucite strips whose sides were polished to permit transmission of a light beam; its cross section was 0.64 by 7.6 cm and length about 75 cm. It was supported on rollers which permitted about one inch travel away from the channel for inserting a diaphragm. A flange with an oval groove to receive a rubber gasket ring provided means to clamp together chamber and channel and to seal the chamber when a diaphragm was in place. A slot in the lower plate contained a solenoid which, when energized, thrust a sharp pointer against the diaphragm causing it to rupture. At the opposite end of the chamber was a fitting for connection to the pressure system.

The pressure in the chamber was raised by use of a tire pump connected with rubber tubing to the chamber and to the pressure measuring device. Pressure was set with an accuracy of 0.01 atmos by using a closed arm mercury manometer. Before taking a series of velocity records, one arm of the manometer

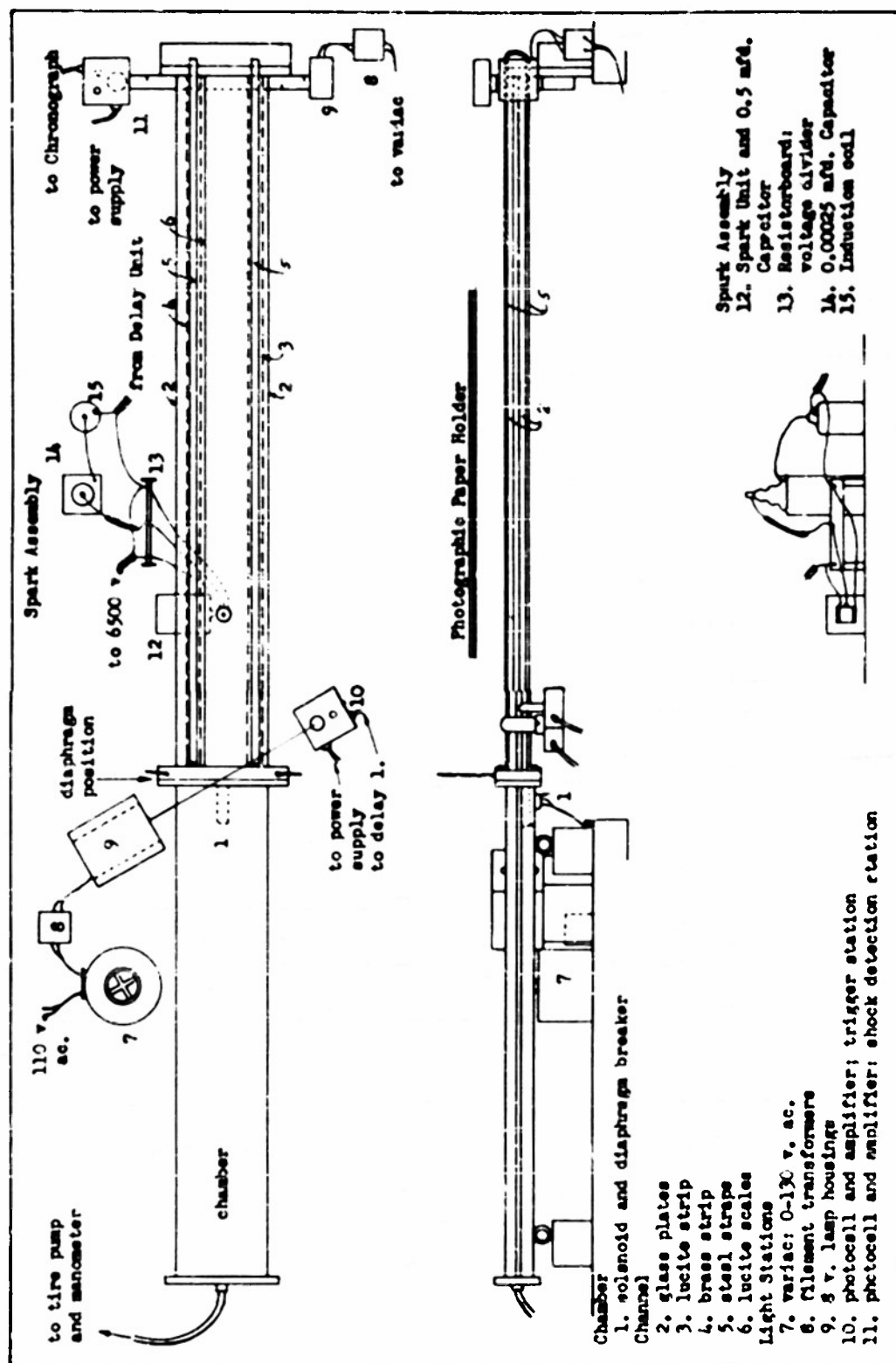

FIG. 2 SHOCK TUBE and SHADOWGRAPH EQUIPMENT

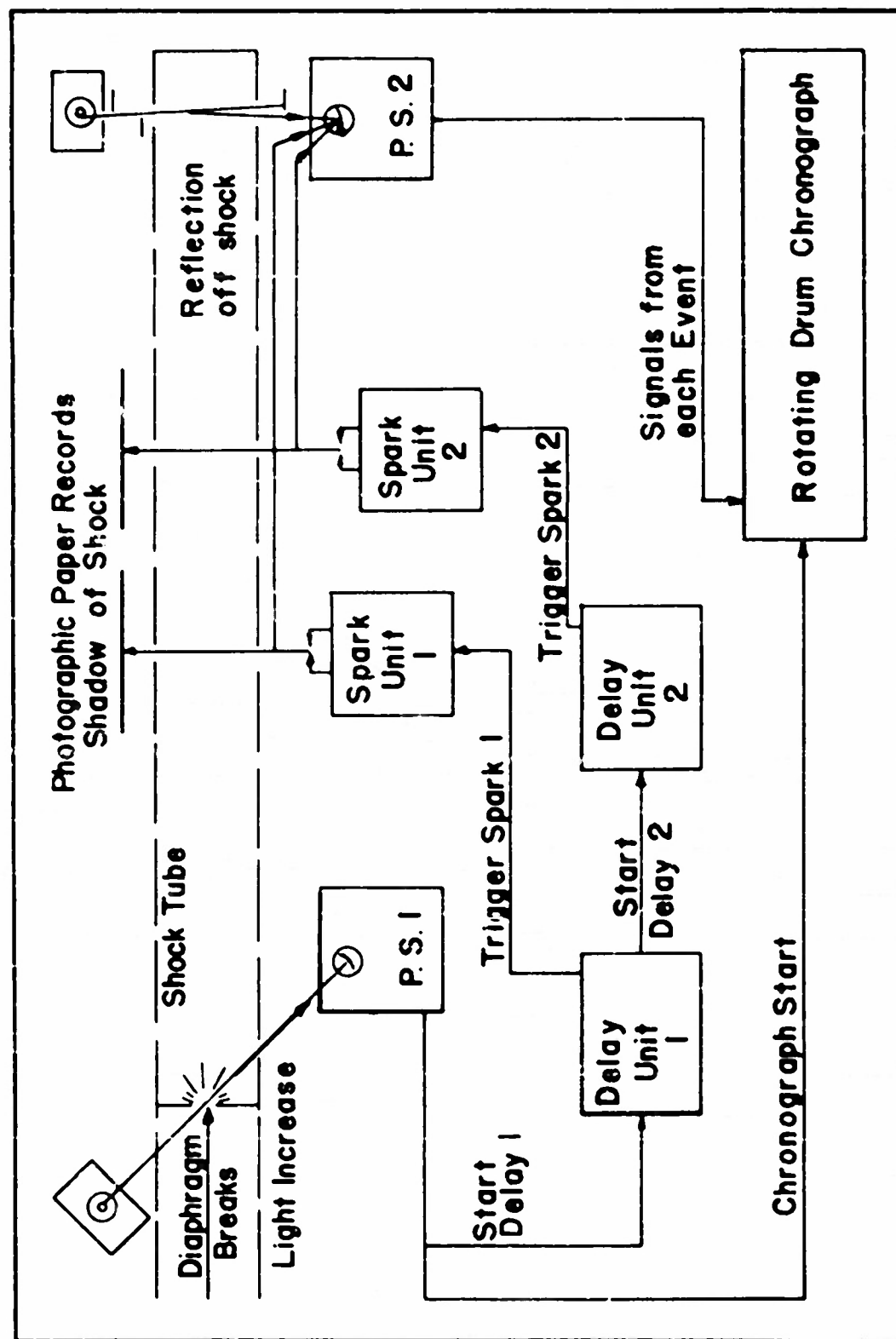

FIG. 3 SEQUENCE of OPERATIONS

was calibrated for the particular pressure of interest by comparison with a hydraulic dead weight gage. The manometer provided a simple and sensitive means for repeating the initial pressure setting from one trial to the next. For the setting of higher pressures (above 45 psig) the dead weight gage alone was used. Atmospheric pressure was recorded from a barometer.

The 7.6 cm channel walls were formed by two pieces of plate glass $1/4$ " by 6" and 30" long. One of the .64 cm thick walls was a strip of brass $1-1/4$ " wide by $28-3/4$ " long; the other was a 1" wide strip of Lucite milled to the .64 cm thickness for its entire length of 30". At the end of the brass strip a small $1-1/4$ by $1-1/4$ " Lucite piece was inserted as a window for the shock detection station. The inner surface of the long Lucite strip forming one wall was polished with fine grit emery paper and oil, and buffed to eliminate irregularities. The outer edge was also polished at each end to allow transmission of light beams used for measuring purposes.

The brass and Lucite strips were cemented to one glass plate with stationers rubber cement which had been thinned with 2 parts of benzene to one part cement. Three layers were applied to each surface of the joint and allowed to dry partially. The strips were placed in accurate position on the

glass, held lightly with C clamps which were then tightened at intervals of about 15 minutes. Use of thick rubber cement resulted in a coating of non-uniform thickness; too rapid application of pressure with the C clamps squeezed the cement out so that a gas tight seal was not obtained. The other glass plate was cemented in place by a similar procedure. Excess cement was removed from the inside of the assembled tube by rubbing with a brass strip inserted at the open ends.

The end of the channel near the diaphragm was surrounded with a 3-1/2" by 8" split wooden yoke which could be clamped against the steel flange of the chamber holding the rubber gasket for the diaphragm seal. This wooden yoke was set slightly away from the end of the glass section to permit the glass to exert positive pressure against the diaphragm. Slippage of the wooden yoke on the glass was prevented by two U-shaped steel straps extending the full length of the channel and surrounding it; these straps were fixed to the yoke at the open ends of the U and pressed against the ends of the glass plates at the closed ends of the U. The steel straps were separated from the glass by cardboard pads, and C clamps at 4" intervals served both to hold the straps to the glass and to maintain pressure on the rubber sealed joints between glass and brass and Lucite strips.

Before the yoke and steel straps were attached in the

final assembly, the end of the channel at the diaphragm was ground flat and smooth with a belt sander. Care was taken to make this flat surface perpendicular to the inside edge of the brass strip and also to the glass plates. This assured that the walls of the channel would be perpendicular to the diaphragm and parallel to those of the chamber when the tube was assembled with a diaphragm in place. The direction of motion of the belt was along the 6" dimension of the glass so that chipping at the edge would not affect the sealing at the diaphragm. The sanding operation caused the Lucite to heat and swell so that after cooling a gap existed at its end. This was effectively filled with three layers of scotch cellophane tape, carefully fitted, and an excellent seal was always obtained.

Dowel pins in holes in the wooden yoke and in the steel flange of the chamber aligned the two sections of the shock tube. The end of the channel near the diaphragm was supported by chains from the ceiling. The other end was rigidly supported by a wooden block fastened to a laboratory table.

Two Lucite scales were fastened along one side of the channel by means of small clips. These transparent scales provided the reference for determining the position of the shocks in the photographs. The scales were ruled by use of a spectrographic comparator; a dot was scribed for each millimeter and a line for each centimeter. Each scale was

72 cm long. One scale was above the channel, the other below, and their shadows overlapped in the photographs, permitting the correction for shock position due to parallax. The divisions on the two scales were aligned by observing the multiple reflections of a line of the upper scale in the glass plates beneath it and the corresponding line of the lower scale.

Photocell Stations. The first photocell station provided a signal at diaphragm rupture which started the delay circuits and chronograph. A narrow light beam passed obliquely through the diaphragm to a 931-A photocell. The sudden increase in light when the diaphragm shattered resulted in a signal from the photocell which was amplified and transmitted to a "gate" unit. The "gate" unit both shaped the pulse to a standard form for transmission to the delay, and prevented later signals resulting from fluctuations in light intensity on the photocell from passing to and interfering with the delay circuit.

The second photocell station at the far end of the channel generated three signals at the times each of two sparks flashed and at the time the shock passed a knife edge optical detection station. The latter was one of the standard arrangements of three knife edges which prevent a light beam from falling on the photocell except during the few microseconds that a shock is passing the plane of the knife edges.

Delay units. The delay units were double triode univibrators

with variable resistance and capacitance in one arm. The delayed pulse from the first univibrator was selected, shaped, and delivered to a thyatron grid; it was also transmitted to a second univibrator delay unit of similar construction, whose output was applied to a second thyatron.

Spark Assemblies. Each of the thyatrons referred to above discharged a capacitor through the primary of an automobile ignition coil. The voltage pulse induced in the secondary triggered the main spark. The construction and wiring of the spark assembly is shown in Figure 4. The spark source consisted of three electrodes axially aligned in a hollow Lucite cylinder ^{3/}. The first electrode was a brass plug which screwed in an end plate to permit adjustment of the electrode spacing; the second was an iron slug with a pin at the end to slide in a hollow insulator of soapstone; the third electrode was a steel insert with a 1 mm diameter hole through its center. Light from the spark confined within the soapstone emerged through the 1 mm hole; the duration of the spark was approximately 1 μ sec, and the intensity was sufficient to give a shadowgram through glass on F-1 Kodabromide enlarging paper at a distance of 100 cm.

Chronograph. The time intervals between the three signals

^{3/} The spark source design was furnished by D. E. Allmand and R. L. Kramer of the Hydrodynamics Subdivision, Naval Ordnance Laboratory, White Oak, Md.

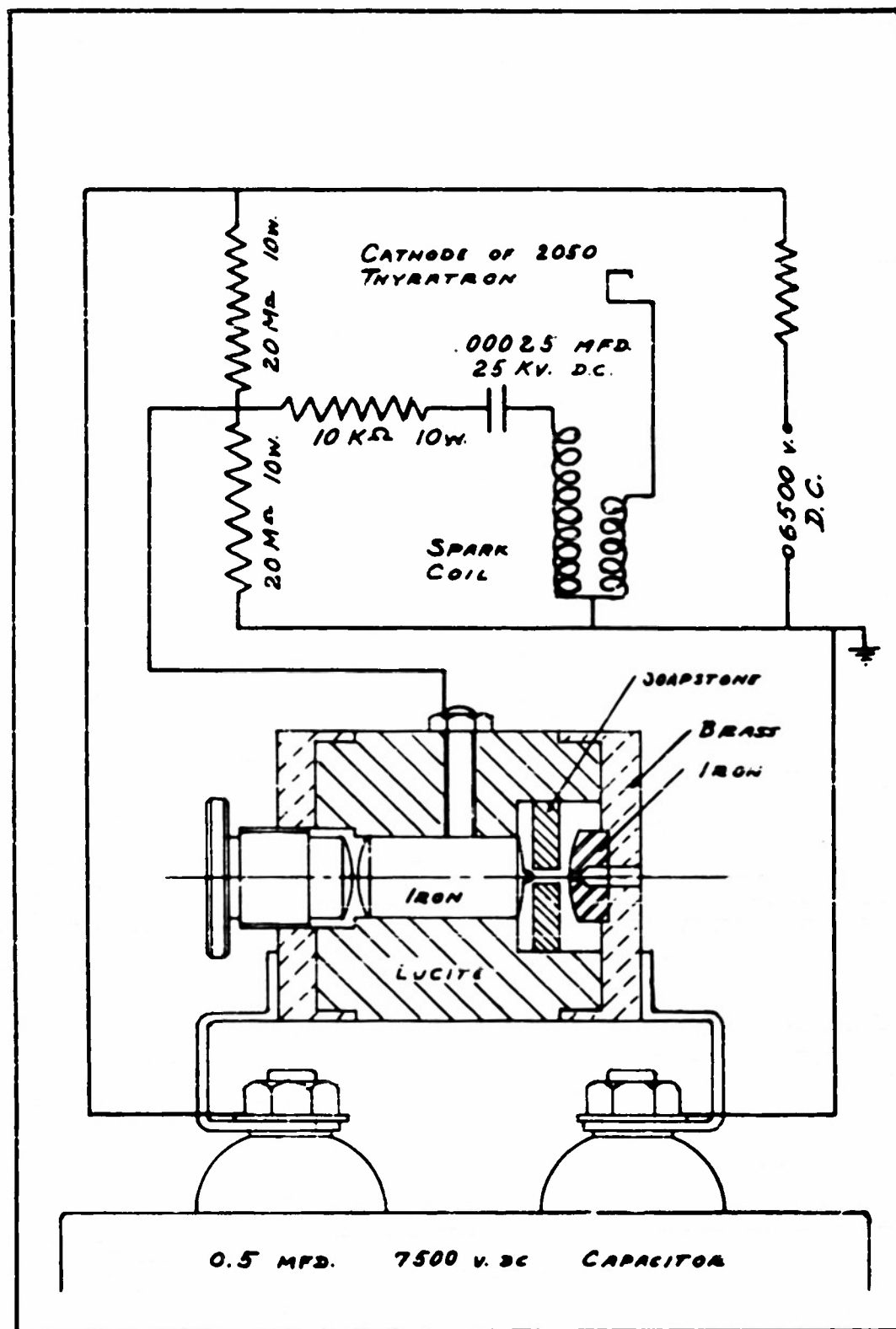

FIG. 4

SPARK ASSEMBLY

generated at the second photocell station were measured with a rotating drum chronograph. In this chronograph, a time base on a cathode ray tube screen is photographed on 35 mm film moving in a rotating drum. Linear motion of the cathode ray spot transversely to the motion of the film is synchronized to a crystal controlled oscillator for 50 μ sec; the direction of the spot motion then reverses for 50 μ sec. Timing markers at 5 μ sec intervals and the signals to be timed deflect the spot in the direction of film motion. Interpolation between timing markers permits the time intervals between the signals to be determined to within 1 μ sec. The cathode ray spot was brightened by the signal resulting from diaphragm rupture and remained bright for just slightly less than one revolution of the drum, i.e. 1/30 sec. A typical chronograph record is shown in Figure 1 of the first reference.

Shadowgraphs. As indicated in Figure 2 the spark sources were placed on the floor 90 cm below the glass channel and photographic paper in a holder was placed 10 cm above the channel. A typical shadowgraph appears in Figure 5.

If the spark flashed at the instant when the shock was directly above the spark source, i.e., when the plane of the shock included the source, the shadow of the shock was an extremely fine line. Usually the shock was displaced by a few centimeters from the vertical through the source so that

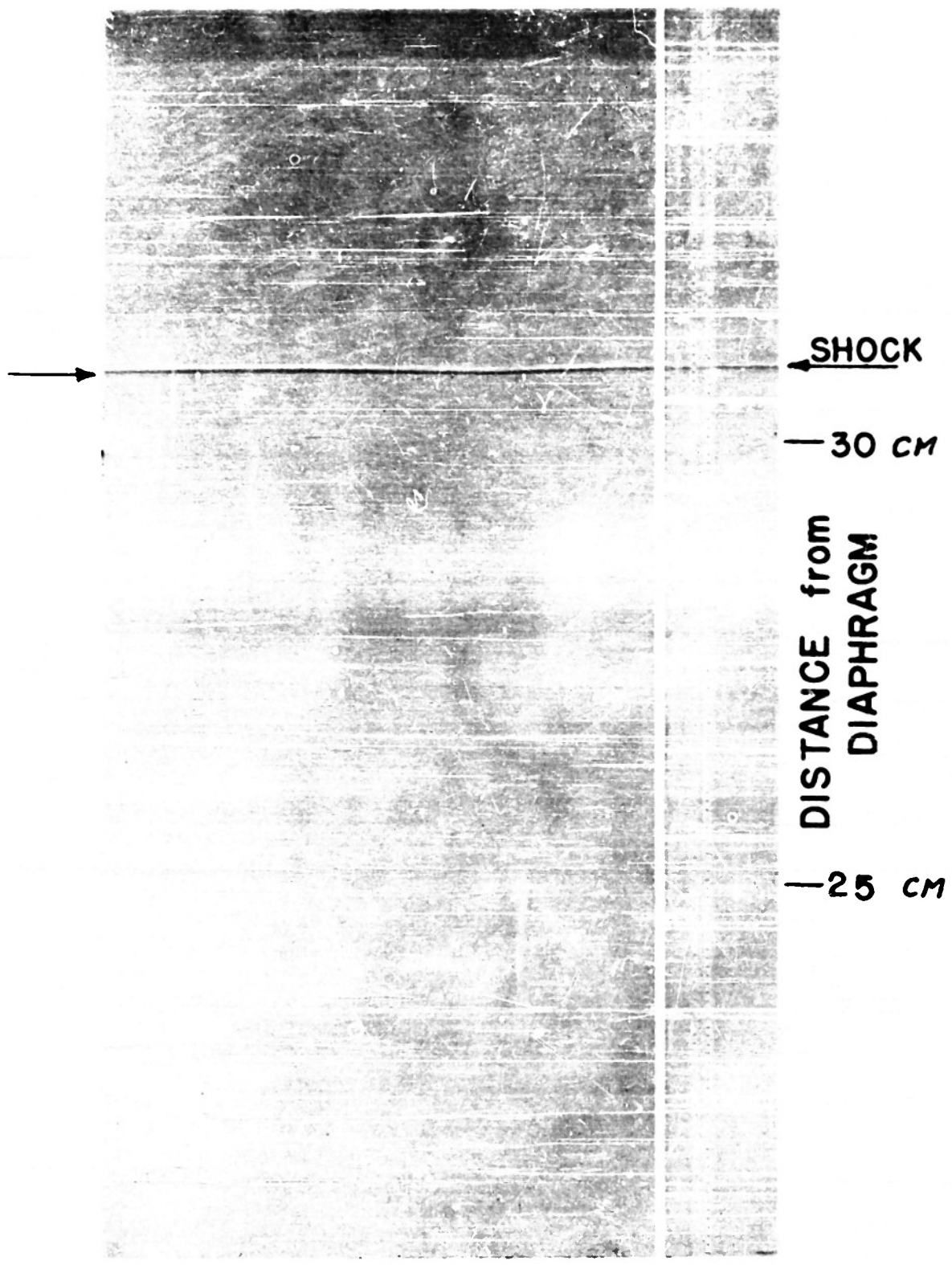

FIG. 5 SHADOWGRAPH

the shadow consisted of neighboring bright and dark lines. The position of the center of these lines is determined relative to the shadows of both the upper and lower transparent scales; the average of the two scale readings is the position of the shock relative to either of the accurately aligned scales.

Position of Shock Detection Station. The position of the knife edge detection station had to be determined relative to the scale appearing in the photographs. An operational method of making this determination was employed. The spark sources and photographic paper were arranged to make a measurement of the shock velocity from two shadowgraphs over an interval of about 10 cm just ahead of the shock detection station. The shadow of the shock from the second spark was about 1 cm ahead of the detection station. By assuming that the shock moved with constant speed over the interval between the first shadow and the detection station, the measured velocity between the shadows and the time interval measured between the second spark and the detection station pulse permitted calculation of the position of the station relative to the scale appearing in the photograph. Three such sets of measurements at each of two shock strengths all indicated the same position of the detection station within ± 0.5 mm.

RESULTS

Four groups of position-time measurements were made for

chamber pressures 15, 30, 45, and 60 psig; channel pressures were atmospheric. These correspond to pressure ratios $P_c/P_o = 2.03, 3.02, 4.09, 5.14$ respectively. Actually P_c/P_o varied slightly from one trial to the next within a given group and more noticeably so when runs were made on different days. However, the differences were always small and an adjustment of results to a common basis as described in the paragraph following the next compensates for variations in initial pressure ratios.

In order to attain as nearly perfect diaphragm breakage as possible, different strengths of cellophane were used at the different pressure ratios. The diaphragms used were as follows:

<u>P_c/P_o</u>	<u>Cellophane Type and Treatment</u>
2.03	.0008" DuPont 300PHT, charred at 250°C for 3 hours, dehydrated; very fragile, near ultimate breaking strength
3.02	.0008" DuPont 300PHT, charred at 175°C for 1 hour, re-hydrated at room humidity (50%); somewhat below ultimate strength
4.09	.0008 DuPont 300PHT, uncharred, dehydrated; near ultimate strength
5.14	.0022" Dobeckmun laminated Red Zip, dehydrated; near ultimate strength

For each trial, the positions and corresponding times of the shock at three places were recorded. From these the average velocity over three intervals were computed. Corrections for

small lack of reproducibility from one trial to the next were made. The positions of the first shock pictures were kept the same. Then all velocities were altered in such a ratio as to bring to a common value all average velocities over the interval from the first shock picture to the detection station. Varying the position of the shock for the second photograph permitted measurement of average velocities over different intervals. By assuming the average velocity over an interval to be the velocity at the mid-point, data for a velocity-distance curve were obtained.

The results appear in the graphs of Figures 6, 7, 8, and 9. Each is a plot of shock Mach number vs. distance from the diaphragm. By using the ratio of the shock velocity to the sound speed in the air ahead of the shock, $M = U/c_0$, the effects of variations in room temperature among trials is eliminated. The value for sound speed is determined from the formula

$$c_0 = 347.4 \left[1 + (t-25.5)/597.2 \right] \text{ m/sec}$$

where t is centigrade temperature determined by a thermometer in good thermal contact with the metal walls of the shock tube chamber. The short horizontal line above the experimental points indicates the value of velocity predicted by the ideal theory of shock tube flow for the pertinent value of P_3/P_0 ^{4/}. The solid diagonal line is an extrapolation from the measurements

^{4/} Bleakney, Weimer, and Fletcher, Rev. Sci. Instr. 20, 807 (1949) equation (10)

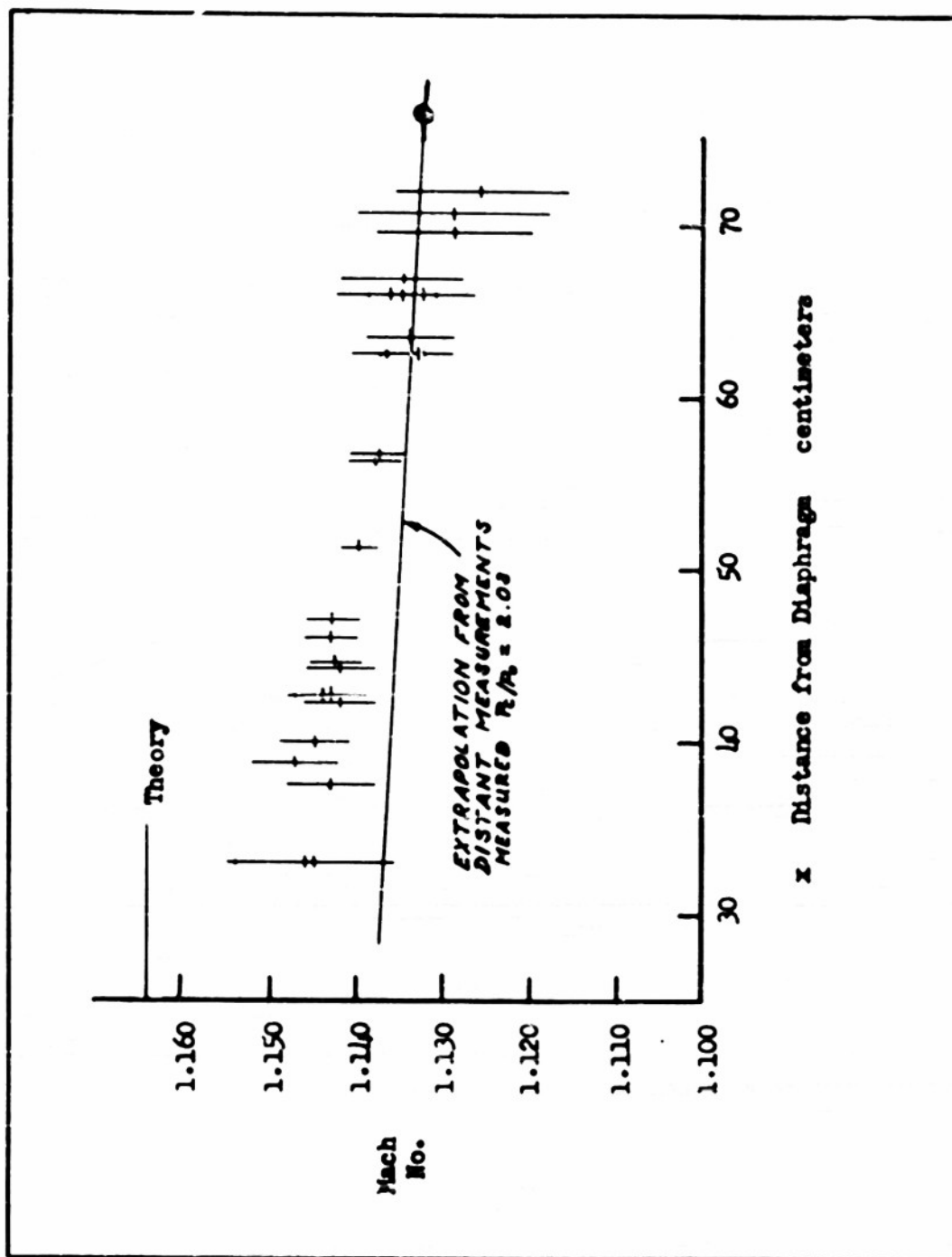

Figure 6 Mach number of Shock vs Distance from Diaphragm. $P_0/P_0 = 2.03$

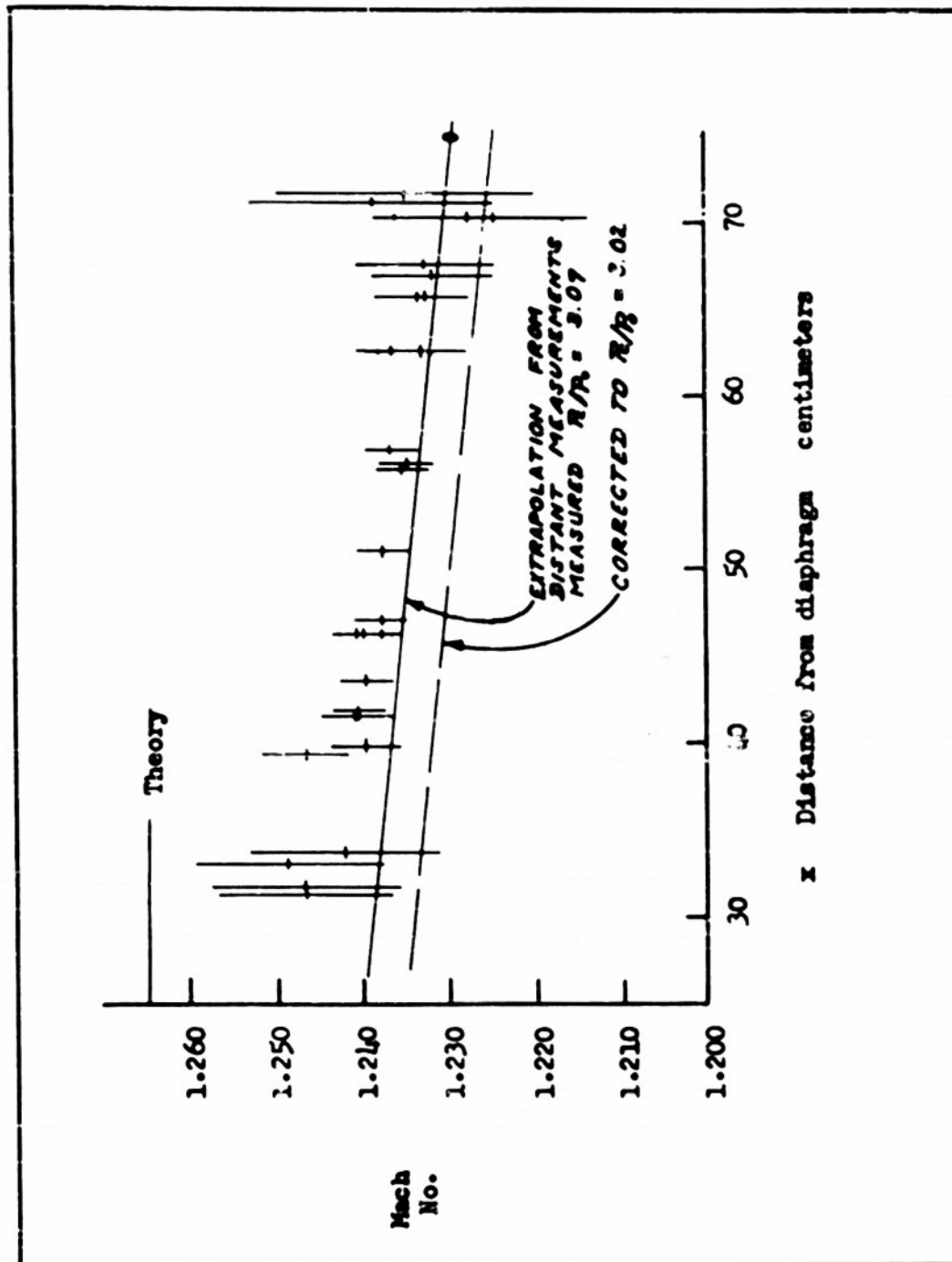

Figure 7 Mach Number of Shock vs Distance from Diaphragm. $p_0/p_0 = 3.02$

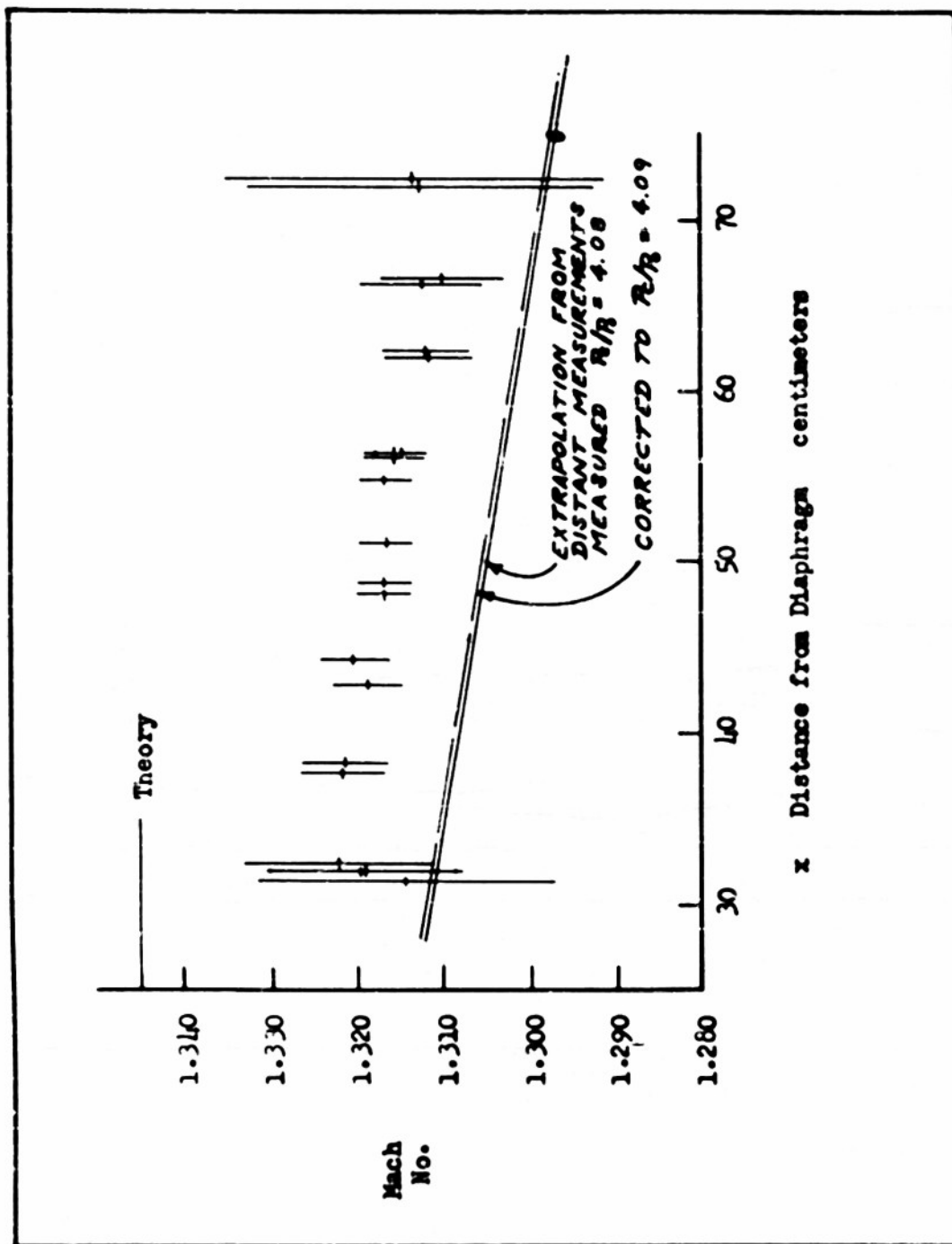

Figure 8 Mach Number of Shock vs Distance from Diaphragm. $P_0/P_0 = 4.09$

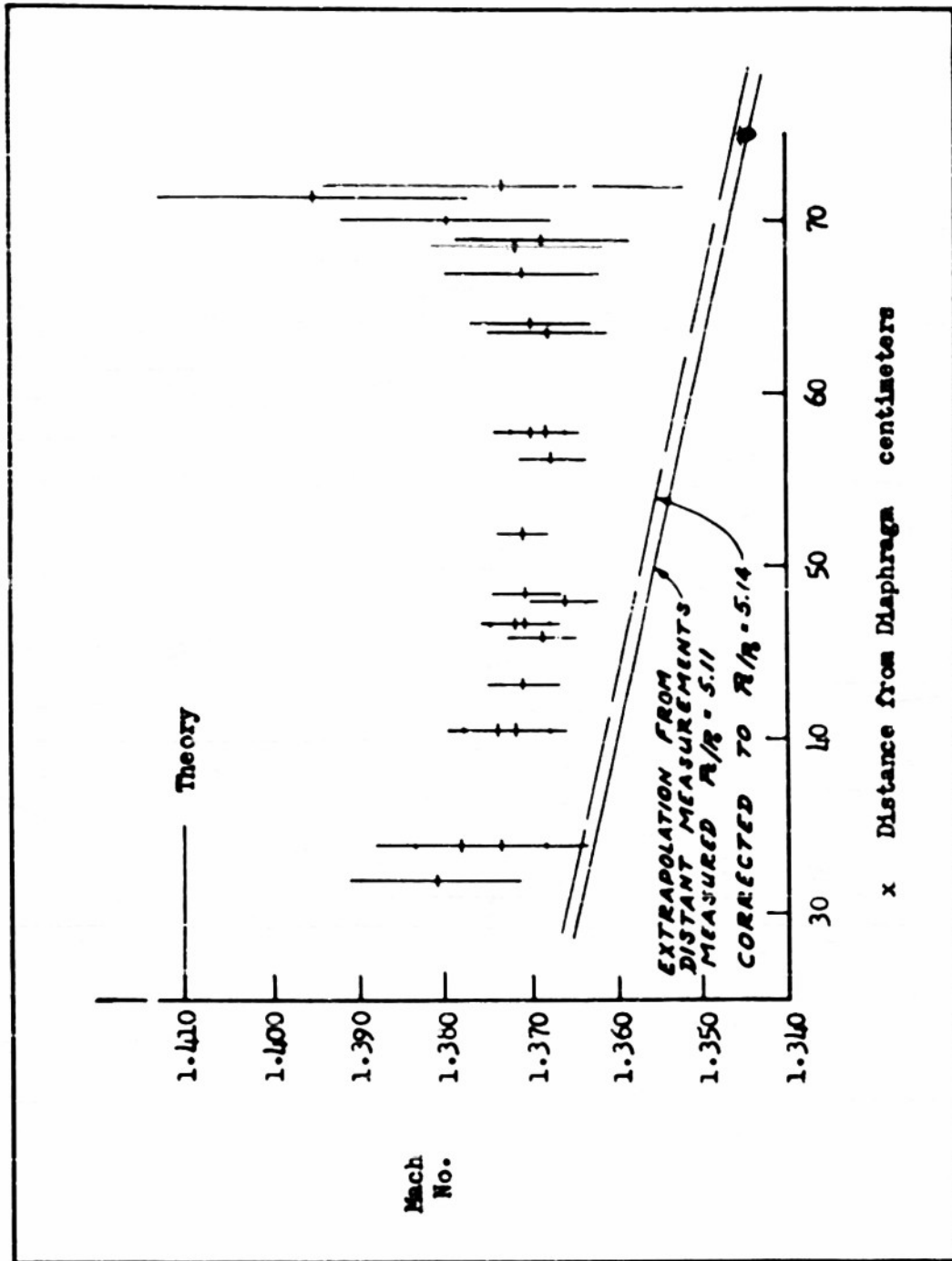

Figure 9 Mach Number of Shock vs Distance from Diaphragm. $p_0/p_0 = 5.14$

of Emrich and Curtis $\frac{1}{2}$. In those cases where the P_c/P_0 value for their data differs slightly from that applying to the presently reported results, a dashed line is also drawn in to indicate the differences in Mach number to be expected on this account. The vertical intervals associated with the measured Mach numbers are estimates of the indefiniteness arising from errors in reading the records alone; these reflect a possible error of ± 1 μ sec in each time interval measurement and of ± 0.3 mm in each distance interval measurement. Such errors are presumably random.

The possible sources of systematic error in Mach number determinations are in distance and time intervals and in sound velocity. Variations of Mach number with travel might also be influenced by a non-uniform cross section of the shock tube. The latter influence is believed to be small since careful measurements of the glass walled channel after assembly indicated changes in cross sectional area in the direction of propagation of less than 0.2 percent. The transparent plastic scales were found to have changed dimension after they were ruled, but appropriate corrections were made to bring the scale readings into conformity with an accurately engraved steel scale. The time base in the chronograph is known with great accuracy by comparison with time signals broadcast by station WWV. The largest systematic error that may be present is associated with temperature gradients existing in the glass

walled chamber. Care was taken to keep heat sources such as lamps and electronic devices as distant as possible and to have lamps on only for the minimum times needed during each trial. If temperature differences along the channel of as much as 3 Centigrade degrees were present, these differences would reflect, through the sound speed values, changes in Mach number with distance of 0.5 percent. Unfortunately the magnitude of this source of error was not realized during the tests and no measurements of temperature gradients were made.

DISCUSSION OF RESULTS

The purpose of these tests employing spark shadowgraph methods was to extend measurements of shock velocity back as near to the diaphragm as possible for comparison with measurements made in the same size tube at relatively great distances from the diaphragm. Shock Mach numbers measured at 75 cm from the diaphragm by the two methods differ significantly in the case of the two higher starting pressure ratios P_c/P_0 . Thus, it does not seem possible to interpret these velocity loss measurements by spark shadowgraphs as merely extending the earlier measurements.

We have no explanation of the discrepancy noted in the preceding paragraph. The most apparent difference in the apparatus used for the two measurements is in the shock tube walls; the glass walls are poorer heat conductors and superficially are smoother than the duralumin walls.

The observation from the measurements at greater distances from the diaphragm that shock velocities decrease continually with travel suggested that, if the velocity could be measured near enough to the diaphragm, the value predicted by the idealized shock tube theory might be found. These measurements by spark shadowgraphs indicate higher velocities nearer to the diaphragm but the ideal theory value is not attained by the time a reasonably plane shock has formed.

As a final observation from these measurements, it may be noted that stronger shocks lose velocity less rapidly. This is in contradiction with the results obtained at larger distances from the diaphragm. It may be that waves resulting from the diaphragm rupture process continue to strengthen the shock over the region studied and counteract to some extent the wall dissipation which tends to decrease the shock velocity.

DISTRIBUTION LIST
for
TECHNICAL REPORTS AND PUBLICATION REPRINTS
NR-061-063

GOVERNMENT AGENCIES

Departments of the Navy, Air Force and Army

- | | |
|--|---|
| <p>5 Office of Naval Research
Department of the Navy
Washington 25, D. C.
Attn: Mechanics Branch (Code 438)</p> <p>Naval Research Laboratory
Washington 20, D.C.</p> <p>10 Attn: Tech. Info. Div. (Code 2028)</p> <p>1 Attn: Mechanics Div. (Code 3800)</p> <p>1 Commanding Officer
ONR Branch Office
150 Causeway Street
Boston, Massachusetts</p> <p>1 Commanding Officer
ONR Branch Office
844 North Rush Street
Chicago 11, Illinois</p> <p>1 Commanding Officer
ONR Branch Office
346 Broadway
New York 13, New York</p> <p>1 ONR Resident Representative
University of Pennsylvania
3320 Walnut Street
Philadelphia 4, Pennsylvania</p> <p>1 Commanding Officer
ONR Branch Office
1030 East Green Street
Pasadena 1, California</p> <p>1 Commanding Officer
ONR Branch Office
1000 Geary Street
San Francisco 9, California</p> <p>1 Naval Postgraduate School
Annapolis, Md.
Attn: Aero Engr. Dept.</p> <p>HQ, USAF, Pentagon
Washington 25, D. C.</p> <p>1 Attn: Chief Scientific Advisor
Air Engineering Development Div.</p> <p>1 Attn: Doc. Dissom Br. (AFOIR-DD)
Directorate of Intelligence</p> | <p>4* Officer in Charge
Office of Naval Research
Navy No.100, Fleet P.O.
New York, New York</p> <p>+ Including 1 copy each for
Dr. Robert E. Meyer
Manchester University
Manchester, England</p> <p>Dr. W. G. Penney
Armament Research Dept.
Fort Halstead, Sevenoaks
Kent, England</p> <p>Bureau of Aeronautics
Department of the Navy
Washington 25, D. C.</p> <p>1 Attn: Design Elements
Div. (DE-3)</p> <p>1 Attn: Tech. Data Div.
(TD-42)</p> <p>1 David Taylor Model Basin
Department of the Navy
Washington 7, D. C.
Attn: Aeromechanics Div.</p> <p>1 Bureau of Ordnance
Department of the Navy
Washington 25, D. C.
Attn: Research and Dev.
Div. (Reb2)</p> <p>1 Naval Ordnance Laboratory
Silver Spring 19, Md.
Attn: Dr. H. H. Kurzweg
(Code AB)</p> <p>1 Naval Ordnance Test Sta-
tion
Inyokern, California
Attn: Reports Unit</p> <p>Bureau of Standards
Conn. Ave. at Upton St.
Washington, D. C.</p> <p>1 Attn: Dr. G.B.Schubauer</p> <p>1 Attn: Mr. Chas.Ravitsky</p> |
|--|---|

distribution list p2

- | | |
|--|---|
| 1 Central Air Documents Office
U.S. Building
Wright-Patterson Air Force Base
Dayton, Ohio | 1 National Advisory Committee
for Aeronautics
1724 F Street N. W.
Washington, D. C.
Attn: Research Info. Div. |
| 1 Commanding General
HQs, Air Materiel Command
Wright-Patterson Air Force Base
Dayton, Ohio
Attn: MCHIXD4 | 1 Director, NACA
Ames Aeronautical Laboratory
Moffett Field, California
Attn: Mr. H. J. Allen |
| 1 Flight Research Laboratory
Wright-Patterson Air Force Base
Dayton, Ohio (MCRP-S3)
Attn: Mr. L. S. Wasserman | 1 Director, NACA
Langley Aeronautical
Laboratory
Langley Air Force Base, Va.
Attn: Mr. J. Stack |
| 1 Office of the Chief of Ordnance
Department of the Army
Pentagon, Washington, D. C.
Attn: Research and Dev. Div. | 1 Director, NACA
Lewis Flight Propulsion
Lab.
Cleveland 11, Ohio
Attn: Mr. A. Silverstein |
| 1 Ballistic Research Laboratories
Aberdeen Proving Ground
Aberdeen, Maryland
Attn: Dr. C. W. Lampson | 1 Research and Development
Board
Department of Defense
Pentagon, Washington, D.C.
Attn: Info. Reqt. Board |
| 1 Armed Forces Special Weapons Project
P.O. Box 2610
Washington, D. C.
Attn: Col. G. F. Blunda | |

Associated Individuals and Government Sponsored Laboratories

- | | |
|---|--|
| 1 Dr. Wm. Bollay
P.O. Box 89
Downey, California | Applied Physics Laboratory
8621 Georgia Avenue
Silver Spring, Maryland
1 Attn: Supervisor Tech.
Reports
1 Attn: Dr. F. K. Elder |
| 1 Dr. L. R. Hafstad
1901 Constitution Ave.
Washington 25, D. C. | 1 Arnold Research Organiza-
tion, Inc.
Rm. 210, 522 Olive Street
St. Louis, Missouri
Attn: Mr. R. Smelt |
| 1 Dr. H. M. Mott-Smith
50 Memorial Drive
Cambridge, Mass. | Cornell Aeronautical
Laboratory
4455 Genesee Street
Buffalo 21, New York
1 Attn: Dr. J. V. Foa
1 Attn: Dr. G. Rudinger |
| 1 Dr. G. N. Patterson
17 Langmuir Crescent
Toronto 9, Ontario | |
| 1 Dr. D. R. White
General Electric Research Laboratory
Schenectady, N. Y. | |

distribution list p8

- | | |
|--|--|
| 1 Jet Propulsion Laboratory
Pasadena, California
Attn: Librarian | 1 Project METEOR
Mass. Institute of
Technology
Cambridge 38, Mass.
Attn: Librarian, Rm
22-001 |
| 1 Arthur D. Little, Inc.
30 Memorial Drive
Cambridge 42, Mass.
Attn: Dr. Wm. Gordon | 1 Project SQUID
Princeton University
Princeton, N. J.
Attn: Librarian |
| 1 Los Alamos Scientific Laboratory
Santa Fe, N. Mex.
Attn: J-1 Division | 1 RAND Corporation
1500 4th Street
Santa Monica, California
Attn: Dr. R. W. Krueger |
| 1 Melpar Electronics Inc.
452 Swann Avenue
Alexandria, Va.
Attn: Mr. W. L. Wittig | 1 Sandia Corporation
c/o CG, Sandia Base
Albuquerque, N. Mex.
Attn: Appl. Physics Div. |
| 1 Midwest Research Institute
Physics Department
4049 Pennsylvania Avenue
Kansas City, Mo.
Attn: Mr. K. L. Sandefur | |
| 1 Ordnance Aerophysics Laboratory
Daingerfield, Texas
Attn: Mr. J. E. Arnold | |
| 1 Project HERMES
General Electric Company
Schenectady, New York
Attn: Mr. C. K. Bauer | |

UNIVERSITY INVESTIGATORS

- | | |
|--|---|
| 1 Amherst College
Department of Physics
Amherst, Mass.
Attn: Prof. A. Arons | 1 John Hopkins University
Dept. of Aeronautical
Engineering
Baltimore 18, Maryland
Attn: Dr. F. H. Clauser |
| 1 Polytechnic Institute of Brooklyn
85-89 Livingston Street
Brooklyn 2, New York
Attn: Dr. A. Ferri | 1 Harvard University
Dept. of Applied Physics
Cambridge 38, Mass.
Attn: Dr. H. W. Emmons |
| Brown University
Providence 12, Rhode Island | University of Illinois
Urbana, Illinois |
| 1 Metcalf Research Laboratory
Attn: Dr. D. F. Hornig | 1 Attn: Dr. C. H. Fletcher |
| 1 Engineering Division
Attn: Professor J. Kostin | 1 Attn: Dr. A. H. Taub |
| California Institute of Technology
Pasadena 4, California | 1 Armour Research Foundation
Illinois Institute of
Technology
3300 Federal Street
Chicago 16, Illinois
Attn: Dr. S. RAYNOT |
| 1 Attn: Dr. H. W. Leipmann | |
| 1 Attn: Dr. H. T. Nagamatsu | |
| 1 Aeronautical Laboratory | |

distribution list p4

- 1 University of California
Engineering Research Projects
Berkeley 4, California
Attn: Dr. R. G. Folsom
- 1 Case Institute of Technology
Cleveland 6, Ohio
Attn: Prof. Gustav Kuerti
Div. of Aeronautical Engr.
- 1 University of Chicago
Yerkes Observatory
William Bay, Wisconsin
Attn: Dr. S. Chandrasekhar
- 1 Cornell University
Grad. School of Aeron. Engr.
Ithaca, New York
Attn: Dr. A. Kantrowitz
- University of Michigan
Ann Arbor, Michigan
1 Attn: Dr. A. M. Kuethe
Dept. of Aeronautical Engr.
1 Attn: Dr. Otto Laporte
Department of Physics
- 1 University of Minnesota
Dept. of Aeronautical Engr.
Minneapolis 14, Minnesota
Attn: Dr. J. D. Akerman
- New York University
Institute of Math and Mech.
53 Washington Square So.
New York 12, New York
1 Attn: Dr. R. W. Courant
1 Attn: Dr. K. O. Friedrichs
- 1 Lehigh University
Physics Department
Bethlehem, Pennsylvania
Attn: Dr. R. J. Emrich
- 1 University of Maryland
Institute for Fluid Dynamics
College Park, Maryland
Attn: Dr. M. M. Martin
- Mass. Institute of Technology
Cambridge 39, Mass.
1 Attn: Dr. J. C. Hunsaker
Aeronautical Engineering Dept.
1 Attn: Dr. H. Guyford Stever
Aeronautical Engineering Dept.
1 Attn: Dr. C. C. Lin
Mathematics Department
- 1 Pennsylvania State College
Physics Department
State College, Pennsylvania
Attn: Dr. R. G. Stoner
- Princeton University
Princeton, New Jersey
1 Attn: Dr. W. Bleakney
Palmer Physical Laboratory
1 Attn: Dr. D. Bershadler
Aeronautical Engr. Dept.
1 Attn: Mr. L. Lees
Aeronautical Engr. Dept.
1 Attn: Dr. J. vonNeumann
Institute for Advanced Study
- 1 University of Virginia
Department of Physics
Charlottesville, Va.
Attn: Dr. J. W. Beams
- 1 University of Wisconsin
Department of Chemistry
Madison, Wisconsin
Attn: Dr. J. O. Hirschfelder
- 1 Yale University
New Haven, Connecticut
Attn: Dr. J. G. Kirkwood
Department of Chemistry