

AD NO. 6253

ASTM FILE COPY

Research

ILLINOIS INSTITUTE OF TECHNOLOGY

Engineering Report No. 5

on

DESCRIPTION, ALIGNMENT AND CHARACTERISTICS

for the

IIT NARROW-BAND LOCK-IN ANALYZER

Contract N7onr-32904
Project NR-264-003

Sponsored by

Department of the Navy
Office of Naval Research

at

Mechanical Engineering Department
Illinois Institute of Technology
Technology Center
Chicago 16, Illinois

Dated: 21 July 1953

Copy No. 010

ACKNOWLEDGMENT

The development and evaluation of the IIT Narrow-Band Lock-in Analyzer was sponsored by the Undersea Warfare Branch, Office of Naval Research... particular assistance being given by Captain J. B. Grady, Mr. H. W. Boehly and Mr. S. W. Doroff.

A similar analyzer was initially developed by personnel at the U. S. Naval Ordnance Laboratory. NOL Report 2142 by Mr. A. Z. Robinson was particularly helpful in the development of the IIT Narrow-Band Analyzer. Mr. Robinson personally advised the IIT group on several occasions.

The following members of the IIT staff performed this assignment under the direction of the undersigned:

D. M. Muster, Assistant Professor of Mechanical Engineering
O. E. Curth, Associate Research Engineer, M. E. Department
L. E. Tybur, Assistant Research Engineer, M. E. Department
R. A. Einweck, Technician, M. E. Department
C. R. Olson, Technician, M. E. Department
M. E. Balog, Technical Secretary

Messrs. Curth and Tybur, assisted by Messrs. Olson and Einweck, designed, built and tested the analyzer.

Respectfully submitted,

Chester A. Arents

Professor Chester A. Arents
Project Director Vibrations Laboratory
Illinois Institute of Technology

Chicago 16, Illinois
July 21, 1953

TABLE OF CONTENTS

<u>Section</u>	<u>Page</u>
Acknowledgment	ii
Table of Contents	iii
I Abstract	1
II Introduction	3
III Description and Circuits of the Analyzer	6
IV Alignment Procedure	14
V Discussion	21
VI Recordings Made by IIF Narrow-Band Analyzer	24
VII Appendix	28
A. Calibration Curves, Plates and Schematic Diagrams	29
B. Distribution List	67

SECTION I

ABSTRACT

SECTION I

ABSTRACT

Illinois Institute of Technology has built a model of the Naval Ordnance Laboratory Narrow-Band Lock-in Analyzer. The analyzer was miniaturized wherever practicable, and minor circuit changes were made. The analyzer is a precision laboratory instrument, attractively mounted in hardwood cabinets.

This new narrow-band analyzer is very useful for low frequency analyses from 1 to 440 cps and for the purpose of observing the variation in frequency and amplitude of discrete frequency components.

SECTION II
INTRODUCTION



Plate I
Narrow Band Analyzer and Recorder (Less cables)

SECTION II

INTRODUCTION

A model of a narrow-band analyzer, originally developed at the Naval Ordnance Laboratory, was built under the sponsorship of the Office of Naval Research, Undersea Warfare Branch under Contract N7onr-32904 awarded to Illinois Institute of Technology. It was anticipated that this analyzer would be used on Contract N7onr-32904 to aid in machinery vibration and noise reduction studies by means of resilient mountings, and would be available to other Tasks for some of their low frequency studies applicable to this type of analyzer. The theory of operation and detailed circuit description of the original model developed by the U. S. Naval Ordnance Laboratory under Task No. NR-261-017, is given in NAVORD Report 2142, dated 4 March 1952. The IIT staff built the analyzer, miniaturizing it wherever practicable, making minor design changes, and mounting it in a cabinet as a laboratory instrument—see Plate 1. This report covers the description of the circuits and their functions, the procedure to be followed in order to align the analyzer, the response characteristics of the major components, and recordings made by the analyzer.

SECTION III
DESCRIPTION AND CIRCUITS OF THE ANALYZER

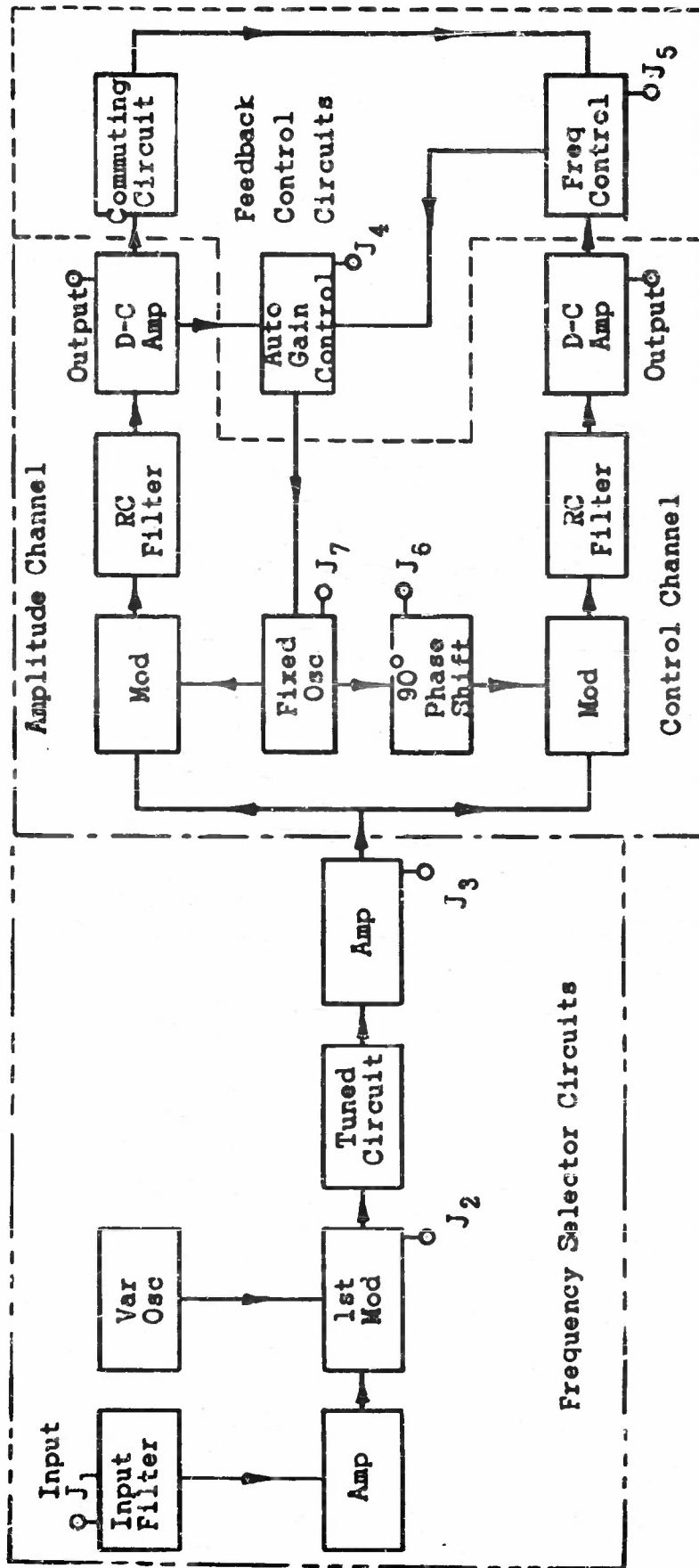

Fig. 1
Block Diagram of Narrow-Band Analyzer

SECTION III

DESCRIPTION AND CIRCUITS OF THE ANALYZER

1. Description

The following is a brief description of the operation of the narrow-band analyzer: Physically it is built on three 8 x 17 x 2 inch chassis. All front panels are standard 19-inch rack panels, the power supply and Chassis No. 1 being seven inches high and Chassis No. 2 five and one-quarter inches. These are mounted, along with the Brush recorder, in oak chests as shown in Plate I.

Fundamentally the operation of the analyzer is as follows: From the frequency components present in the signal to be analyzed, a discrete frequency is selected by heterodyning it to a constant (so-called "carrier") frequency of 4800 cps. The resulting signal is fed into two parallel channels where the carrier frequency is again heterodyned. A zero beat results and simultaneously the two channels are placed in quadrature. One channel, called the amplitude channel, is used to obtain the amplitude of the selected component. The other channel, called the control channel, is used to keep this component of the incoming signal in the center of the pass band by controlling the frequency of the heterodyning oscillator. This arrangement enables the present narrow-band analyzer to discriminate between frequency and amplitude changes in the incoming signals, unlike most constant and percentage band-width analyzers.

2. Circuits

The input signal will be traced through the analyzer and the function of the major analyzer components will be briefly described—see Fig. 1 for block diagram.

A. Frequency Selector Circuits: These circuits are similar to a heterodyne-type analyzer. The incoming signal passes through a Low Pass Input Filter which rejects frequencies above 440 cps and prevents the overloading of the input stages by large amplitude signals above 440 cps. This is necessary, because in the process of heterodyning, if all frequencies were permitted to enter the analyzer, extraneous difference frequencies would result and lead to an erroneous reading. The Variable Frequency Oscillator has a range from 4360 to 4800 cps, and the desired carrier frequency is the sum of the incoming frequency and the oscillator frequency. For example, if the incoming signal frequency is 80 cps, the variable oscillator is tuned to 4720 cps in order to produce 4800 cps or the desired carrier frequency. Now, if the incoming signal did not pass through a low pass filter and had a 9520 cps frequency component along with an 80 cps component, the analyzer would read the magnitude of both frequency components... the difference between 9520 cps and the oscillator frequency is 4800 cps which would give an erroneous result.

Since only 4800 cps (carrier frequency) is selected, input frequencies that fall between 0 and 440 cps will heterodyne with the oscillator signal to produce this carrier. This implies that the frequency range of the analyzer is 0 to 440 cps. However, the actual useful range of the analyzer is from 1 to 440 cps because of various circuit instabilities.

The oscillator frequency and the incoming signal frequencies are then heterodyned in the Ring Modulator Circuit. The sum and difference frequencies go into a Tuned Circuit which selects only 4800 cps.

Summarizing, the incoming signal is limited to frequencies from 0 to 440 cps by the Low Pass Input Filter. These low range frequencies are added to the frequency of the Variable Frequency Oscillator. The Tuned Circuit selects the carrier frequency of 4800 cps, which is made up of the incoming signal and the oscillator frequency.

B. Amplitude and Control Channels: The amplitude and control channels receive the carrier frequency from the tuned circuit and associated amplifier. This carrier frequency is fed directly into the ring modulators. In addition the ring modulator in the amplitude channel receives a 4800 cps signal from the fixed frequency oscillator. Likewise, the ring modulator in the control circuit receives the 4800 cps signal from the fixed frequency oscillator but the signal is shifted 90 degrees by a phase shifting network before entering the ring modulator. Since the oscillator frequency is the same as the carrier frequency, a zero beat is produced in each ring modulator. The amplitude of the d-c voltage produced by zero beating becomes a function of the two signals (carrier and fixed oscillator signals) and the phase angle between them. For example, assume the carrier frequency voltage to be

$$E_f = A \cos(\omega_1 t + \phi_1) \quad (1)$$

the fixed oscillator frequency voltage to the amplitude channel ring modulator to be

$$E_{fa} = B \cos(\omega_1 t + \varphi_2) \quad (2)$$

the fixed oscillator frequency voltage to the control channel ring modulator to be

$$E_{fc} = B \sin(\omega_1 t + \varphi_2) \quad (3)$$

where ω_1 in each case is $2\pi \cdot 4800 = 30,160$ rad. per sec. Now, in the amplitude channel ring modulator the following takes place:

$$E_f \cdot E_{fa} = E_a \quad \text{or}$$

$$E_a = \frac{AB}{2} \left[\cos \left\{ (\omega_1 + \omega_1)t + \varphi_1 + \varphi_2 \right\} + \cos \left\{ (\omega_1 - \omega_1)t + \varphi_1 - \varphi_2 \right\} \right] \quad (4)$$

and in the control channel ring modulator the following takes place:

$$E_f \cdot E_{fc} = E_c \quad \text{or}$$

$$E_c = \frac{AB}{2} \left[\sin \left\{ (\omega_1 + \omega_1)t + \varphi_1 + \varphi_2 \right\} + \sin \left\{ (\omega_1 - \omega_1)t + \varphi_1 - \varphi_2 \right\} \right] \quad (5)$$

The beat frequency voltages (4) and (5) are next applied to a low pass RC filter which rejects all a-c components and equations (4) and (5) become

$$E_a = \frac{AB}{2} \cos(\varphi_1 - \varphi_2) \quad (6)$$

$$E_c = \frac{AB}{2} \sin(\varphi_1 - \varphi_2) \quad (7)$$

Examination of equations (6) and (7) show that if $(\phi_1 - \phi_2)$ equals zero, the sin function becomes zero and cos function reaches a maximum and is proportional to the amplitude of the component of the incoming signal being analyzed.

The voltages, equations (6) and (7), are fed into two d-c amplifiers. Actually each voltage magnitude is directly proportional to a quadrature component of the signal being analyzed.

Both d-c amplifiers feed their output signals into the frequency feed-back control circuits. In addition the d-c amplifier in the amplitude channel feeds the amplitude channel galvanometer and the channel in the Brush Recorder indicating the amplitude of the component of the incoming signal being analyzed; and the d-c amplifier in the control channel feeds the control channel galvanometer and the channel in the Brush Recorder indicating frequency lock-in.

- C. Frequency Feed-Back and Control Circuits: The signal from the d-c amplifier in the amplitude channel is fed into the commuting circuit, while the signal from the d-c amplifier in the control circuit is fed into the frequency control or frequency shifting circuit. The commuting circuit operates in conjunction with the frequency control circuit to provide the proper phase voltage feed-back to the fixed oscillator so that it will lock-in on the incoming signal component. When the oscillator is locked-in on the incoming signal component, the meter in the control channel will indicate zero... $\phi_1 - \phi_2 = 0$, therefore $\frac{AB}{2}\sin(\phi_1 - \phi_2) = 0$. The primary purpose of the commuting circuit is to permit the analyzer to follow any sudden 180° phase shift in the incoming signal.

The feed-back voltage controls the frequency of the fixed oscillator and passes through an automatic gain control circuit, which, in turn, controls the amplitude of the feed-back voltage according to the magnitude of the signal present in the amplitude channel. As the analyzer is tuned to a frequency component, the signal in the amplitude channel increases, while at the same time the feed-back voltage decreases. The automatic gain control and frequency control circuits are so designed that once the analyzer is tuned to a signal, no frequency feed-back voltage is fed to the fixed oscillator. However, if the source drifts slightly in frequency, the analyzer will follow the drift indicating it by a deflection of the control galvanometer. There is a manual adjustment of the feed-back voltage, which determines the range of lock-in frequency. By means of the feed-back control circuits the phase angle in the control channel is automatically adjusted so that the amplitude in this channel approaches zero while the amplitude in the amplitude channel approaches the maximum value. Thus, when the analyzer is tuned to a frequency and the control channel indicator reads zero, the amplitude channel will indicate the amplitude of the incoming frequency.

SECTION IV
ALIGNMENT PROCEDURE

SECTION IV

ALIGNMENT PROCEDURE

The succeeding paragraphs outline an alignment procedure which is to be followed...especially after the analyzer has not been used for long periods.

A. Chassis No. 1, includes oscillators, first ring modulator, band pass or carrier frequency transformer, and phase shifting network.

1. Preliminary adjustments prior to alignment of the components in Chassis No. 1

- a. Place Chassis II in normal position and center galvanometers, if necessary, by adjusting the adjustment screw located in the front of the meter movement.
- b. Connect all inter-connecting cables between the three chassis.
- c. Set all attenuators to position 20 or maximum attenuation.
- d. Connect the analyzer to 110-volt, 60-cycle power source and permit it to warm up for at least one hour before making any further adjustments.
- e. Connect a d-c voltmeter between ground and the +220VDC jack on the front power supply panel.
- f. Adjust potentiometer under +220VDC jack with a screw driver until the d-c voltmeter indicates +220 volts.
- g. Repeat steps (e) and (f) for the -220VDC jack and potentiometer; adjust the voltage to -220 volts d-c instead of +220 volts.

2. Fixed Frequency Oscillator

- a. Connect cathode-ray oscillograph to J₇ and ground.
- b. Form Lissajou figure between signal at J₇ (fixed frequency oscillator) and a frequency standard of a harmonic or sub-harmonic of 4800 cps.

- c. Adjust fixed oscillator control on Chassis No. 1 until oscillator is oscillating at 4800 cps. (The 8th harmonic of the 600 cps signal transmitted by Station WWV, Washington, D. C. provides an excellent frequency standard for this adjustment.)

3. Phase Shifting Network

- a. Compare the phase angle between the signals at J_6 and J_7 by means of a cathode-ray oscillograph or a phase-angle meter.
- b. Adjust PHASE¹ control on Chassis No. 1 until a 90° phase shift is indicated between the two signals from J_6 and J_7 .

4. Variable Frequency Oscillator

- a. Set the frequency dial on Chassis No. 1 to zero.
- b. Set INTER ATTEN knob to zero, i.e., minimum attenuation.
- c. Connect the cathode-ray oscillograph and obtain a Lissajou figure between J_7 and J_3 . (It may be necessary to turn P_3 on Chassis No. 1 slightly in either direction to obtain a clear Lissajou figure.)
- d. Adjust VAR OSC control of Chassis No. 1 until variable frequency oscillator is oscillating at the same frequency as the fixed frequency oscillator.

5. Carrier Frequency Transformer

- a. Connect an external a-c voltmeter between J_3 and ground or connect the voltmeter on Chassis No. 1 to J_3 by switching the METER selector switch to J_3 position.
- b. Set INTER ATTEN to position 14.
- c. Turn P_3 completely clockwise.

¹In this section, words in capital letters indicate corresponding panel or chassis markings.

- d. Tune BAND PASS control until a peak voltage is shown on either the front panel a-c voltmeter or on an external a-c voltmeter connected to J_3 .

6. First Ring Modulator

- a. Connect a cathode-ray oscillograph and a high impedance input a-c voltmeter between J_2 and ground.
 - b. Turn METER selector switch to J_2 .
 - c. Adjust P_3 on Chassis No. 1 until 0.3 volt is indicated on the panel voltmeter.
 - d. Adjust P_1 and P_2 on Chassis No. 1 to form perfect square waves on the oscilloscope. (Use 1200 cps sweep to obtain 4 cycles per sweep.)
 - e. Rebalance P_3 until about 0.02 volt appears at J_2 .
 - f. Rebalance P_1 and P_2 again until a square wave appears on the oscillograph.
 - g. Turn METER selector switch to J_3 .
 - h. Set INTER ATEN control on Chassis No. 1 to zero.
 - i. Proceed to rebalance P_3 until the external a-c voltmeter connected to J_2 reads below 0.01 volt (it will drift between 0.004 and 0.008 volt), or the front panel voltmeter on Chassis No. 1 reads below 0.3 volt.
- B. Chassis No. 2, includes second ring modulators, d-c amplifiers, commut-
ing circuits, frequency control and automatic gain circuits.
1. Preliminary adjustments prior to alignment of components in Chassis No. 2.
 - a. Set frequency dial on Chassis No. 1 to 50.
 - b. Set all attenuators on Chassis No. 1 to 20 (maximum attenuation).

- c. Set D.C. ATTEN on Chassis No. 2 to maximum sensitivity by turning knob clockwise.
- d. Set FILTER on Chassis No. 2 to wide band by turning knob fully counter clockwise.
- e. Set RECORDER switch to OUT position.

2. D-C Amplifier Balance

- a. Remove both 1N42 diodes which are connected to the two d-c amplifiers.
- b. Adjust BALANCE controls on front panel of Chassis No. 2 until galvanometers indicate zero.
- c. With a d-c voltmeter on the terminal of one of the galvanometers adjust potentiometer in back of Chassis No. 2 so that the voltage between ground and this terminal is zero.

Note: The potentiometers on the back at the right and left sides control the amplitude channel and control channel voltage levels, respectively.

- d. Check the other terminal of the same galvanometer to be certain that it, too, is at zero potential with respect to ground. If it is not, repeat balancing with BALANCE control on the front panel.
- e. Repeat steps (c) and (d) for the other d-c amplifier (0.05 volt drift in the d-c potential between ground and meter terminal can be tolerated).
- f. Replace the 1N42 diodes to their proper sockets and again measure the d-c voltage between the meter terminal and ground. If this voltage is greater than 0.1 v d-c proceed to balance potentiometer on side of Chassis No. 2 until the voltage becomes less than 0.1 volt. This balances the second ring modulator.

Note: The rear and front potentiometers on the right side of the chassis control the amplitude and control channel voltage levels, respectively.

- g. Check the other terminal of meter to see that it has the same d-c potential as was just measured in step (f).
- h. Repeat this balancing procedure for the other d-c amplifiers.

3. Frequency Control Circuits

- a. Connect cathode-ray oscillograph and a-c voltmeter between J_5 and ground.
- b. Balance potentiometer under control meter until output at J_5 is balanced with not more than 0.03 volt a-c appearing between ground and J_6 .

4. Automatic Gain Control Circuit

- a. Adjust voltage between ground and J_4 to -9.0 volts d-c with lower CONTROL knob.
- b. Set CONT ATTEN at 5, INPUT ATTEN at 10 and INTER ATTEN at 18 on Chassis No. 1.
- c. Apply a 100 cps signal to analyzer and set frequency dial at 22.
- d. Adjust tuning dial about the 22 setting until control channel indicates a zero reading.
- e. Set the control channel reading to zero and increase or decrease the signal source amplitude until the amplitude galvanometer indicates 20.
- f. Turn the upper CONTROL knob on front panel until the d-c voltage between ground and J_4 is -14.0 volts.

5. Commuting Circuits

- a. Set all attenuators to 20 (maximum attenuation).

- b. Remove 12AX7 tube (V16) from socket.
- c. Measure the d-c voltage between pin 2 of the tube socket and ground and between pin 7 and ground.
- d. If these voltages are not equal adjust the potentiometer under the amplitude galvanometer until the d-c voltage between pin 7 and ground is equal to the d-c voltage between pin 2 and ground.

C. Operating Adjustments

Items that are to be checked before actual use of analyzer, or during its operation:

- a. Both galvanometers must indicate zero with INPUT ATTEN set at 20.
- b. (1) The voltage at J_2 must not exceed 0.01 volt when frequency dial is set at zero and INPUT ATTEN set at 20
(2) Less than 0.3 volt must be indicated on the front panel meter with METER selector switch in J_3 position and INTER ATTEN at zero setting.
- c. When frequency dial is set at 50.0, analyzer should be analyzing 440 cps. Check this against the 440 cps signal transmitted by Station WWV.
- d. For frequency measurements below 10 cps, check both oscillators against Station WWV 600-cps signal just before making actual measurements.
- e. If any of the above items do not check repeat the adjustment as specified earlier.
- f. It is imperative that the analyzer be permitted to warm up for at least one hour before attempting any adjustments or putting it to use.

SECTION V

DISCUSSION

SECTION V

DISCUSSION

The IIT-NBA was designed to (1) sweep through a frequency spectrum from 1 to 440 cps and (2) to lock-in on a discrete frequency to determine the manner in which it varies.

Most analyses are motivated by a desire to learn the discrete frequencies present in an incoming signal, their respective amplitudes and how they vary with time...this can be accomplished with the analyzer. When an incoming signal is fed to the analyzer: First, one manually sweeps through frequency spectrum to determine the proper setting of the attenuators. The recorder is mechanically connected and it drives the analyzer through the frequency spectrum. From the recording it is possible to determine several of the higher amplitude frequencies present in the incoming signal. Also, on the recording one will find low or no amplitude areas which are investigated by increasing the gain of the analyzer... this will show whether or not discrete frequencies are present and determine their amplitudes. The curves thus obtained are frequency vs amplitude curves. Second, one will choose a particular frequency he wishes to investigate. The analyzer is adjusted to this frequency and the recorder is mechanically disconnected so it does not drive the analyzer...electrically the recorder and analyzer are connected. The recorder is started and one records amplitude and frequency deviation vs time. The important feature of this type of analyzer is the fact that one can dwell on a discrete frequency and determine whether it deviates in amplitude or frequency.

The analyzer was designed specifically to analyze low frequency components and, as is mentioned earlier, to determine whether a frequency component varies either in frequency or amplitude. Although there are

many commercial analyzers available, none have both of these two desirable features.

In general, the analyzer requires more time in preliminary adjustments than the commercial type analyzers, the dynamic range for any particular setting is less than that of a conventional analyzer, and it requires a different technique of operation. However, it is felt that the extra time required for operation is offset by the advantages of the analyzer. For a hurried sweep through a frequency spectrum, it is better to use a commercial-type analyzer than the IIT-NBA. Nevertheless, by taking the signal from J_3 a similar sweep through a frequency spectrum can be accomplished with the IIT-NBA unit with somewhat less selectivity than on the commercial models.

To summarize, the IIT-NBA is very useful for low-frequency analyses and for the purpose of observing the variation in frequency and amplitude of discrete frequency components.

SECTION VI

RECORDINGS MADE BY IIT NARROW-BAND ANALYZER

SECTION VI

RECORDINGS MADE BY IIT NARROW-BAND ANALYZER

Actual recordings made by the analyzer are shown in Fig. 2, page 27.

Chart I shows the type of frequency-amplitude curve which results when the analyzer is swept through a fixed frequency. It shows clearly that the control channel signal drops to zero when the amplitude channel indicates maximum amplitude. At this zero point the analyzer is exactly tuned to the incoming signal frequency. The region between the oscillations in either the control or amplitude plot is the region of frequencies over which the analyzer is locked-in on the incoming signal. It is well to mention that the amplitude peak could have been below the equilibrium or zero signal point as well as above. The position of this point depends entirely on how the analyzer happens to lock-in on the incoming signal.

Chart II shows the analyzer locked-in on a fixed frequency. This is a plot of the amplitude and frequency variation with time. The amplitude channel shows no amplitude variation in the incoming signal and the control channel shows no frequency deviation.

Chart III is an actual test on a small air compressor. The analyzer received its signal from an accelerometer on the air compressor. It is a frequency vs amplitude plot. Three distinct frequencies are easily identified on this chart. They are designated as points 1, 2, and 3. Points 1 and 2 are relatively well defined, and point 3 is much smaller in magnitude.

Chart IV is similar to Chart III except that it is divided into two regions, A and B. Region A is exactly the same as Chart III with the exception that point 2 is inverted because of analyzer lock-in conditions. In Region B the attenuators were set to a different setting in order to

accentuate point 3.

Chart V is a frequency deviation and amplitude variation vs time plot of point 1. The control channel plot in this chart definitely shows a frequency deviation and the amplitude plot shows an amplitude variation which seems to be repeated.

Chart VI is a frequency deviation and amplitude variation vs time of point 2. It also shows both frequency and amplitude changes with time.

CHARTS SHOWING ACTUAL OPERATION OF NARROW-BAND ANALYZER, MODEL IT7-22A-1

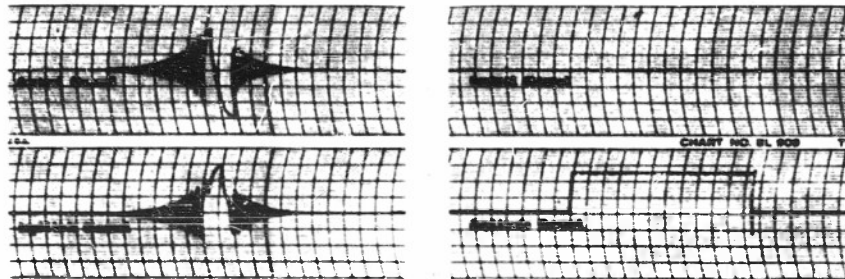

CHART I

CHART II

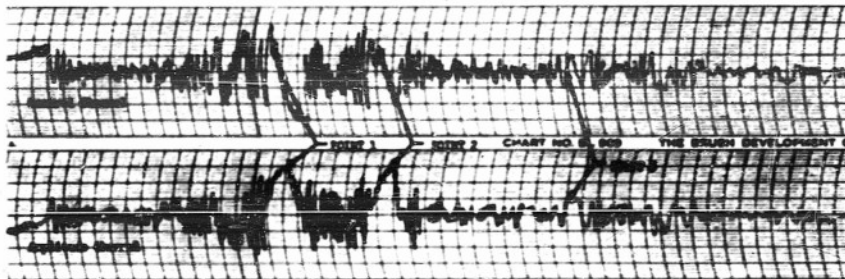

CHART III

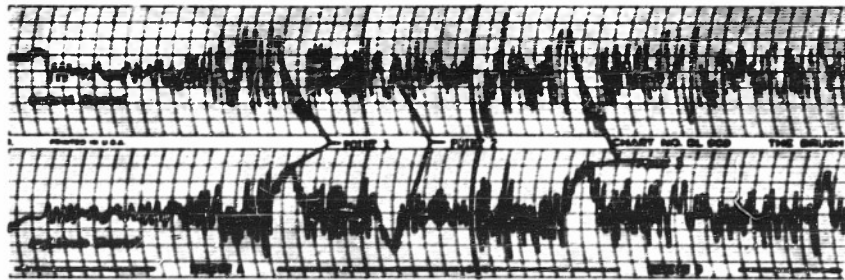

CHART IV

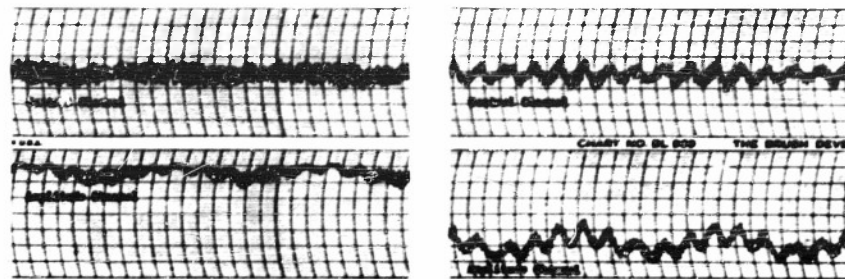

CHART V

CHART VI

Fig. 2

SECTION VII

APPENDIX

APPENDIX A

	<u>Page</u>
I. Characteristic Curves of Analyzer Circuits	
Discussion of Curves	30
Figure 3 - Frequency Response Curve	31
Figure 4 - Dial Setting vs Frequency Curve	32
Dial Setting vs Frequency Data	33
Figure 5 - Db Calibration Curve of Recorder Chart	34
Attenuator Calibration Data	35
Figure 6 - Dynamic Response Curve of Input Amplifiers and First Ring Modulator	36
Figure 7 - Dynamic Response Curve of Carrier Frequency Amplifiers	39
Figure 8 - Dynamic Response Curve of Control and Amplitude Channels	40
Figure 9 - Input Filter Response Curve	41
Figure 10 - Tuned Circuit Response Curve	42
Figure 11 - Response Curves of Low Pass RC Filters	43
II. Plates Showing Construction of Analyzer	
Plate II - Top View of Power Supply Chassis	45
Plate III - Bottom View of Power Supply Chassis	47
Plate IV - Top View of Chassis No. 1	49
Plate V - Bottom View of Chassis No. 1	51
Plate VI - Top View of Chassis No. 2	53
Plate VII - Bottom View of Chassis No. 2	55
III. Schematic Diagrams	
Power Supply Schematic	56
Part List of Power Supply	57
Chassis No. 1 Schematic	59
Part List of Chassis No. 1	60
Chassis No. 2 Schematic	62
Part List of Chassis No. 2	63
Specifications for Special Inductors and Transformers.	66

I. CHARACTERISTIC CURVES OF ANALYZER CIRCUITS

A. Frequency Response Curve - Fig. 3

The IIT-NBA was designed for a frequency range of from 1.0 to 440 cps. The frequency response curve shows a flat response up to 250 cps. It drops 2 db between 250 cps and 440 cps.

B. Dial Setting vs Frequency Curve - Fig. 4

The frequency dial is calibrated to read from 0 to 50 while the analyzer covers the range from 1.0 to 440 cps. The frequency corresponding to each dial setting is given in Fig. 4.

C. Db Calibration Curve of Recorder Chart - Fig. 5

This curve shows the variation in the output of the recorder corresponding to a db change in the input signal. Variations of 16 db can be read on the recorder chart. Larger variations can be obtained by use of the attenuators. The attenuators were designed for 3 db steps but there is some variation in the response of the individual attenuators. Data listed on page 35 show the actual attenuation per step. However, the d-c attenuator was found to have 10 db per step.

D. Dynamic Response Curves of Different Sections of the Analyzer

Since there are several attenuators in the analyzer, dynamic response curves are given to prevent overloading the amplifier stages between attenuators.

1. Dynamic Response Curve of Input Amplifiers and First Ring Modulator - Fig. 6.

This curve shows that the input amplifiers and the first ring modulator circuits will be overloaded when the output at J_2 exceeds 0.6 volt a-c.

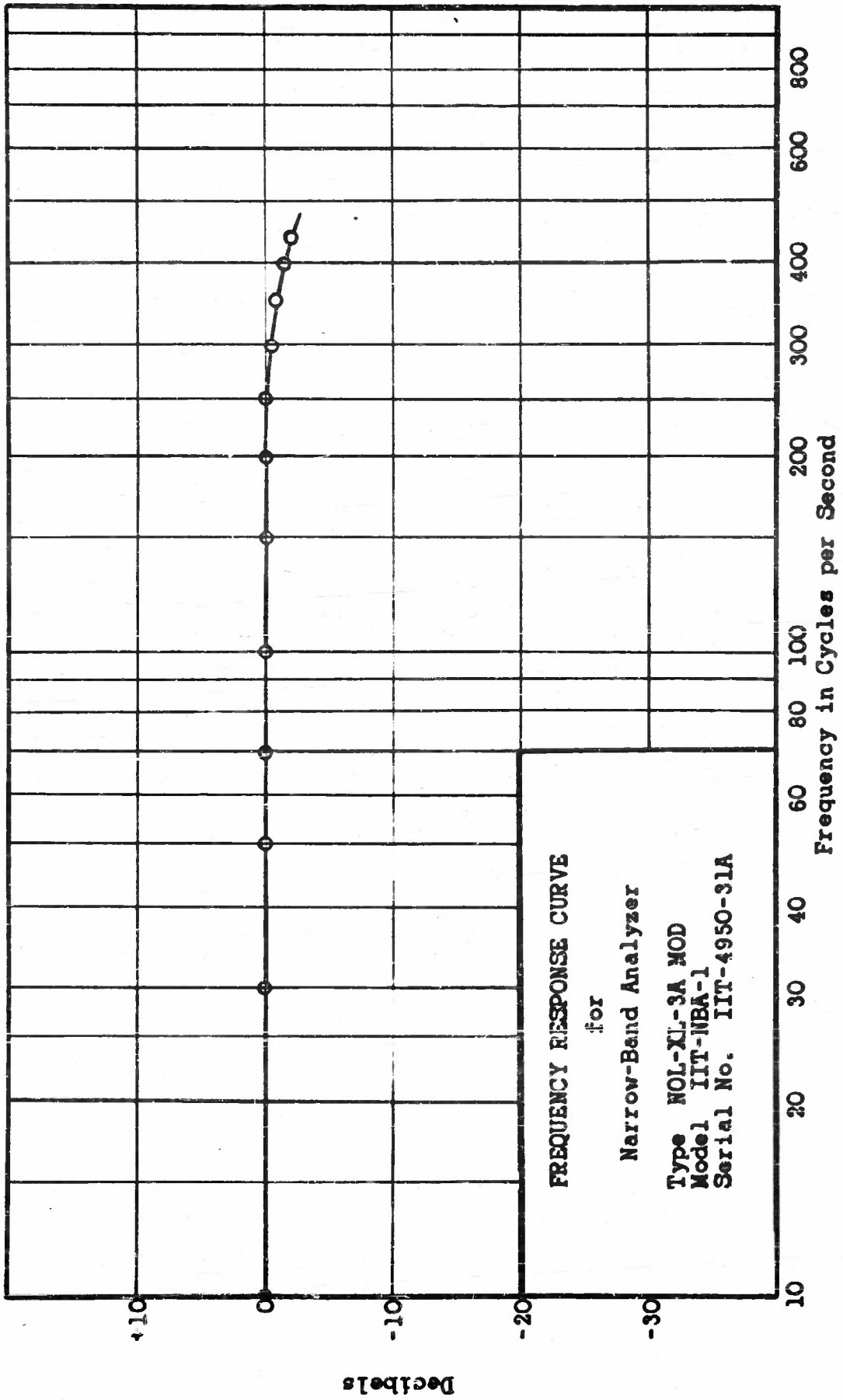

Fig. 3

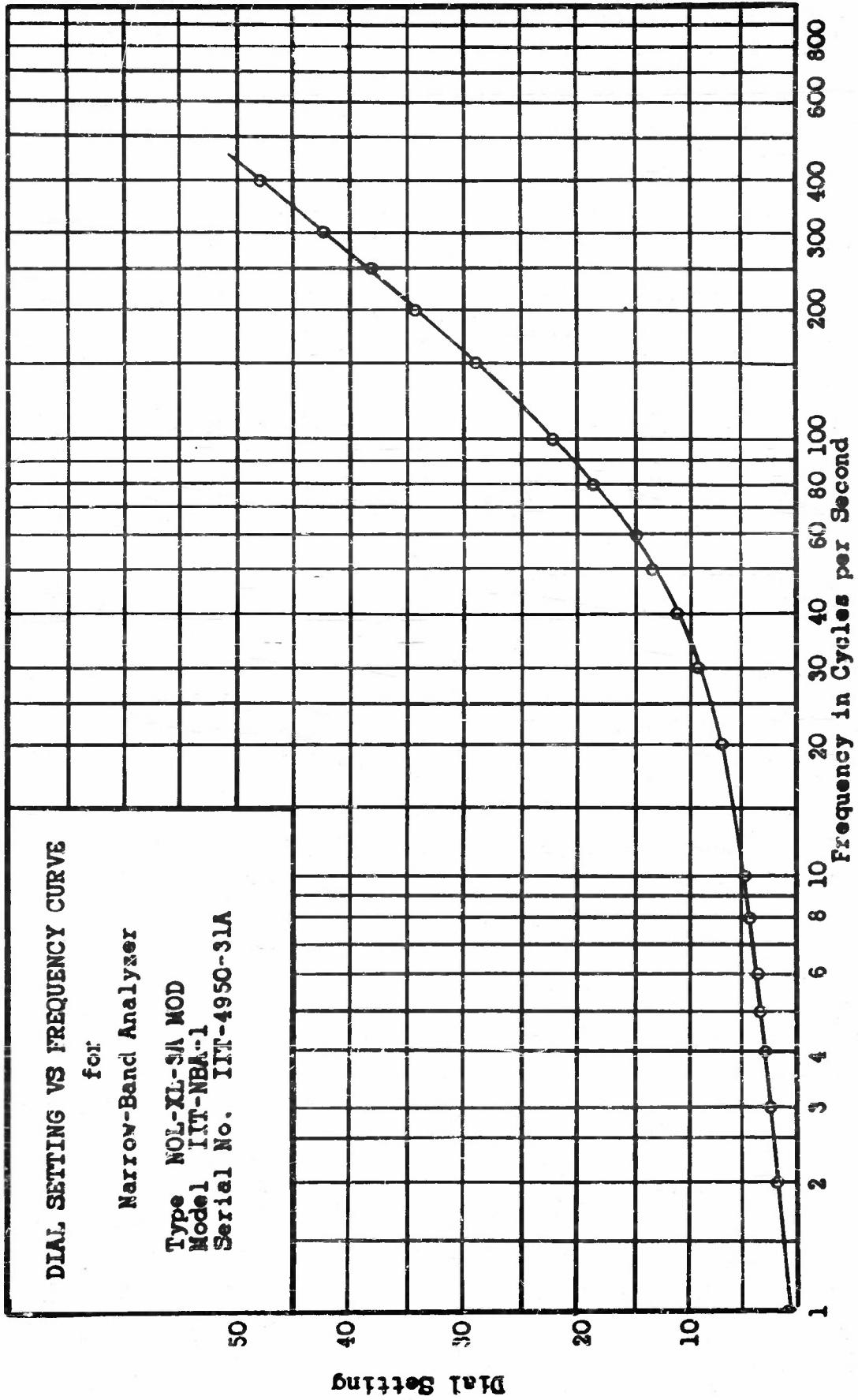

Fig. 4

DIAL SETTING VS FREQUENCY DATA

<u>Frequency, cps</u>	<u>Dial Setting</u>
440	50.0
400	47.7
350	44.9
300	41.8
250	38.0
200	33.7
170	30.7
160	29.5
150	28.4
140	27.1
130	25.9
120	24.6
110	23.3
100	21.8
90	20.3
80	18.7
70	16.9
60	15.2
50	13.3
40	11.3
30	9.4
20	7.1
10	4.7
9	4.4
8	4.2
7	3.9
6	3.6
5	3.3
4	3.0
3	2.6
2	2.1
1	1.1

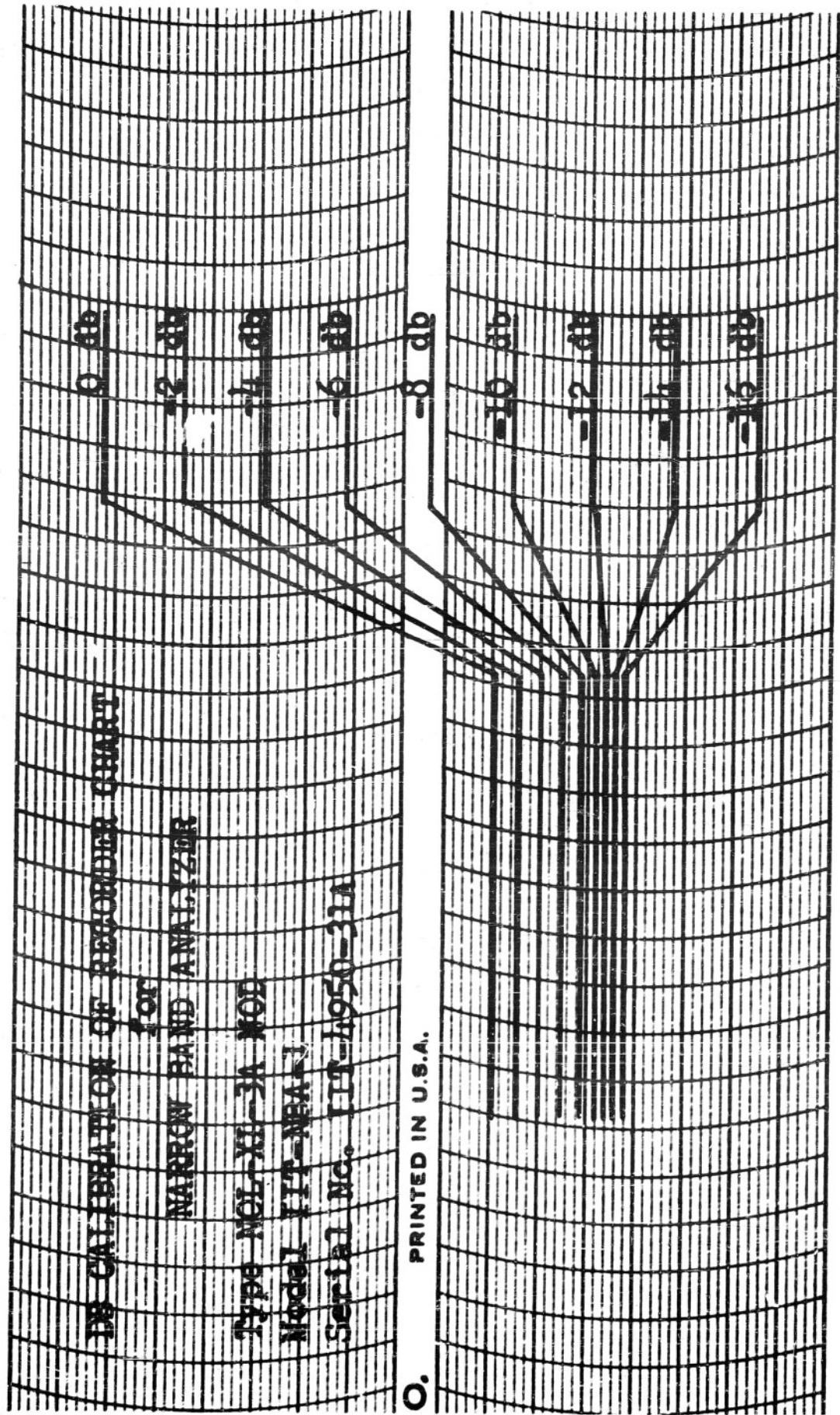

Fig. 5

ATTENUATOR CALIBRATION DATA

<u>Input Atten Setting</u>	<u>DB Drop Per Setting</u>	<u>Total DB Drop</u>
0	0.00	0.00
1	3.00	3.00
2	3.00	6.00
3	3.00	9.00
4	3.00	12.00
5	3.00	15.00
6	3.00	18.00
7	2.75	20.75
8	3.25	24.00
9	3.00	27.00
10	3.25	30.25
11	3.00	33.25
12	3.00	36.25
13	3.00	39.25
14	3.00	42.25
15	3.00	45.25
16	2.50	47.75
17	3.00	50.75
18	3.00	53.75
19	3.25	57.00
20		

<u>Inter Atten Setting</u>	<u>DB Drop Per Setting</u>	<u>Total DB Drop</u>
0	0.00	0.00
1	3.00	3.00
2	3.00	6.00
3	2.75	8.75
4	3.00	11.75
5	3.00	14.75
6	3.00	17.75
7	3.00	20.75
8	3.00	23.75
9	3.00	26.75
10	2.75	29.50
11	3.00	32.50
12	3.00	35.50
13	3.00	38.50
14	3.25	41.75
15	3.00	44.75
16	3.00	47.75
17	3.00	50.75
18	3.00	53.75
19	3.00	56.75
20		

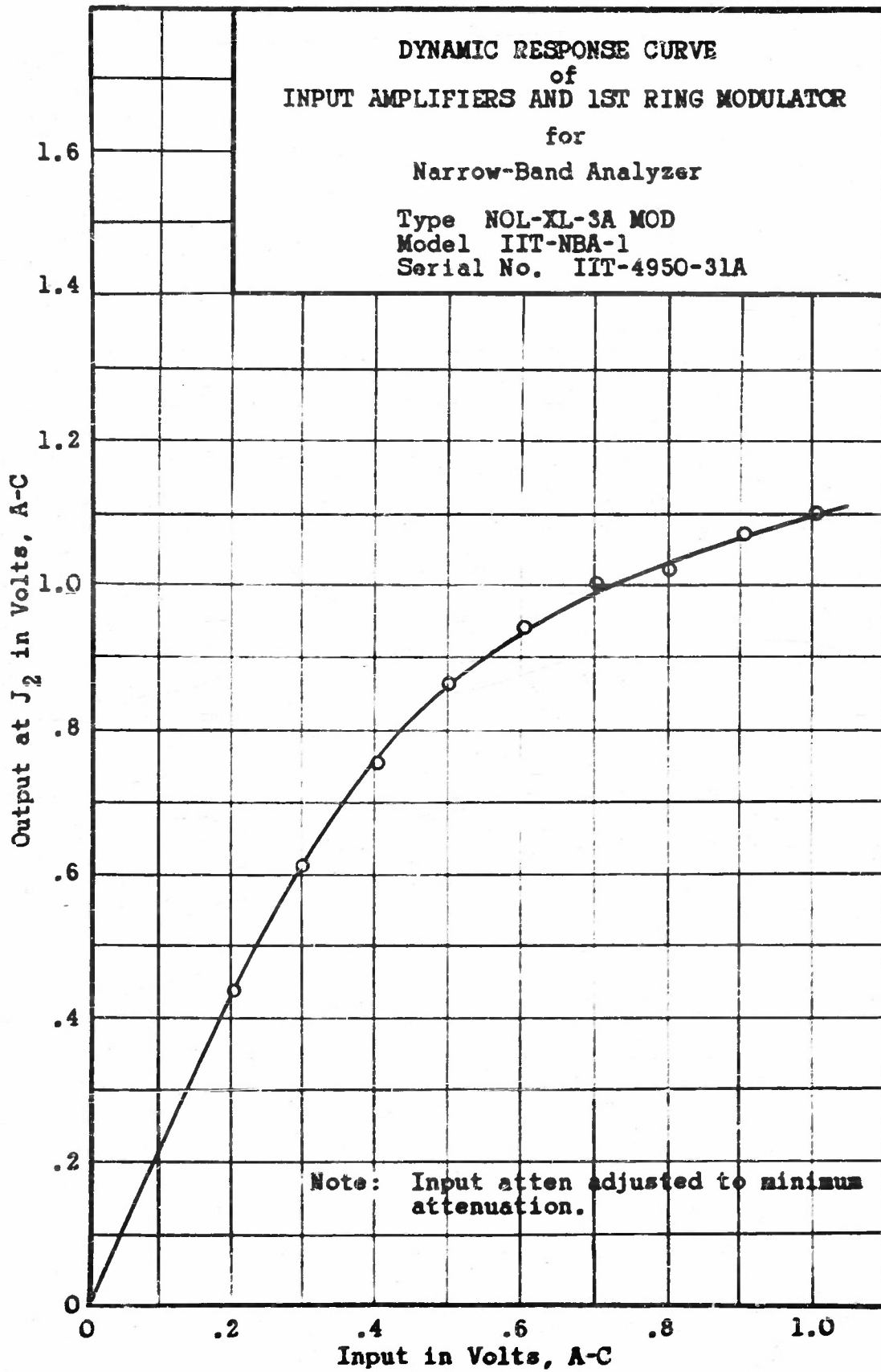

Fig. 6

2. Dynamic Response Curve of Carrier Frequency Amplifiers - Fig. 7

This curve shows that the carrier frequency amplifiers will be overloaded when the output at J_3 exceeds 2 volts a-c.

3. Dynamic Response Curve of Control and Amplitude Channels - Fig. 8.

This curve shows that the control and amplitude channels will be overloaded when the d-c galvanometer reading exceeds 19 microamperes.

The dynamic response curves 1, 2, and 3 above, show that the control and amplitude channels will overload prior to an overload of the carrier frequency amplifiers. The control and amplitude channels are overloaded at approximately a 0.4 v a-c input, whereas the carrier frequency amplifiers are capable of delivering 2 v a-c undistorted. Therefore, the control and amplitude channels limit the output of the carrier frequency amplifiers to approximately 0.4 v a-c.

Since the inter-attenuator is located between the input amplifiers and the carrier frequency amplifiers, there is danger of overloading the input amplifiers. It is seen in Fig. 6 that the output of the input amplifiers cannot exceed 0.6 v a-c without overloading.

E. Filters and Tuned Circuit Curves

1. The Input Filter Response Curve, Fig. 9, shows the response of the input filter.
2. The Tuned Circuit Response Curve, Fig. 10, shows the frequency-db response of the tuned circuit.
3. The Response Curves of the Low Pass RC Filters, Fig. 11, show

the frequency-db response. A curve is given for each position of the filter selector. The front panel control is marked to show the wide-band (WB) and the narrow-band (NB) positions of the switch.

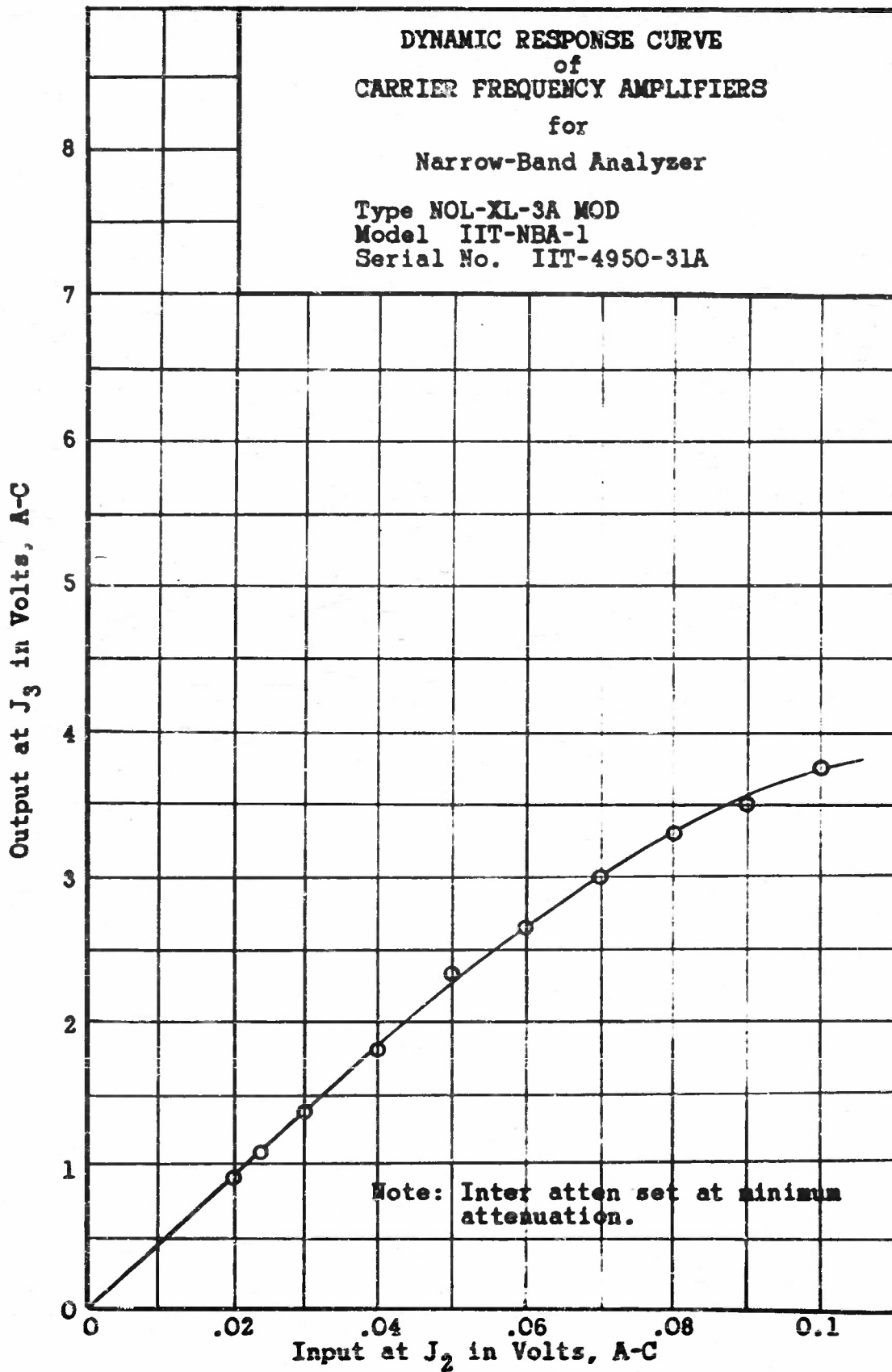

Fig. 7

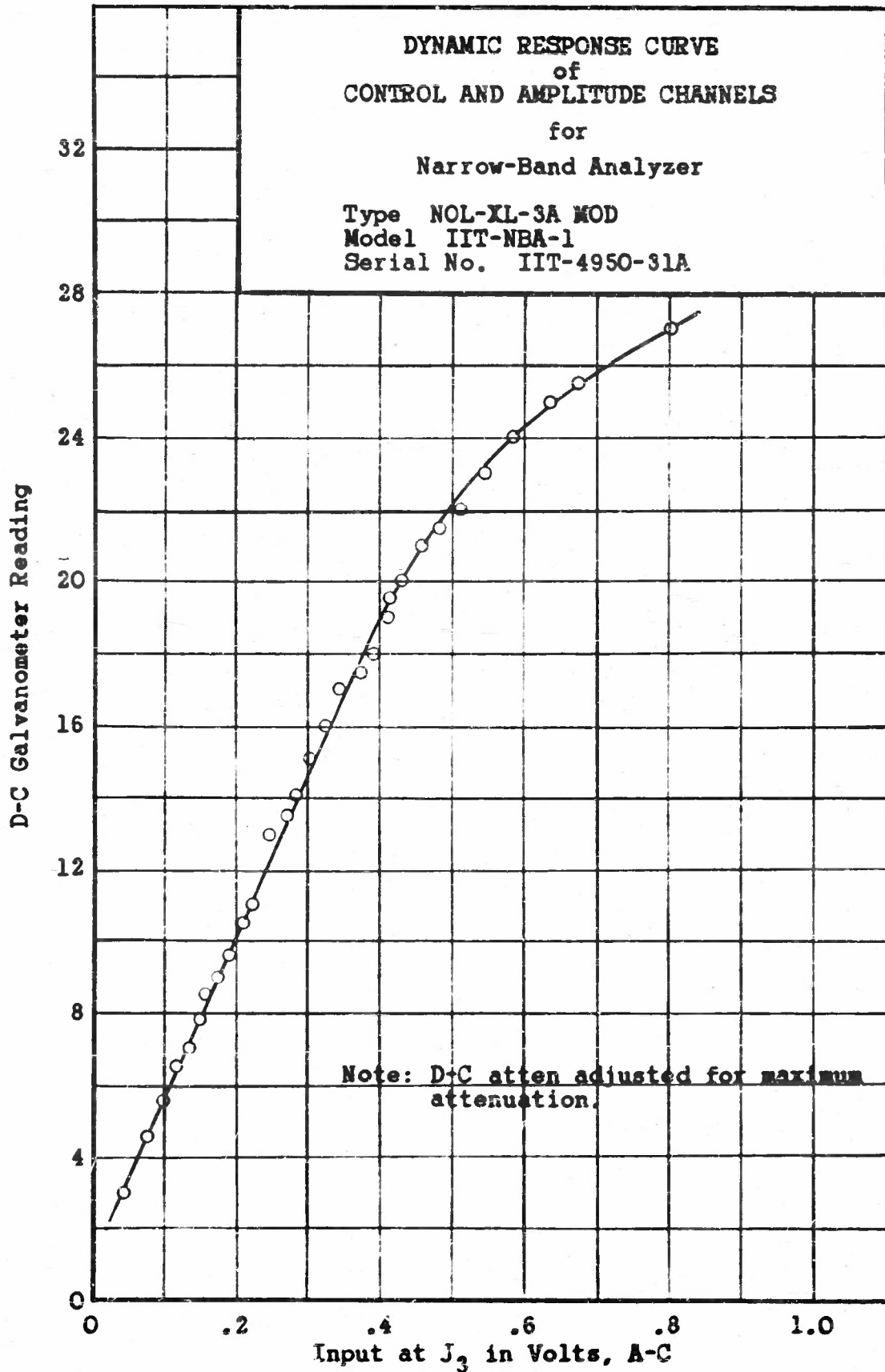
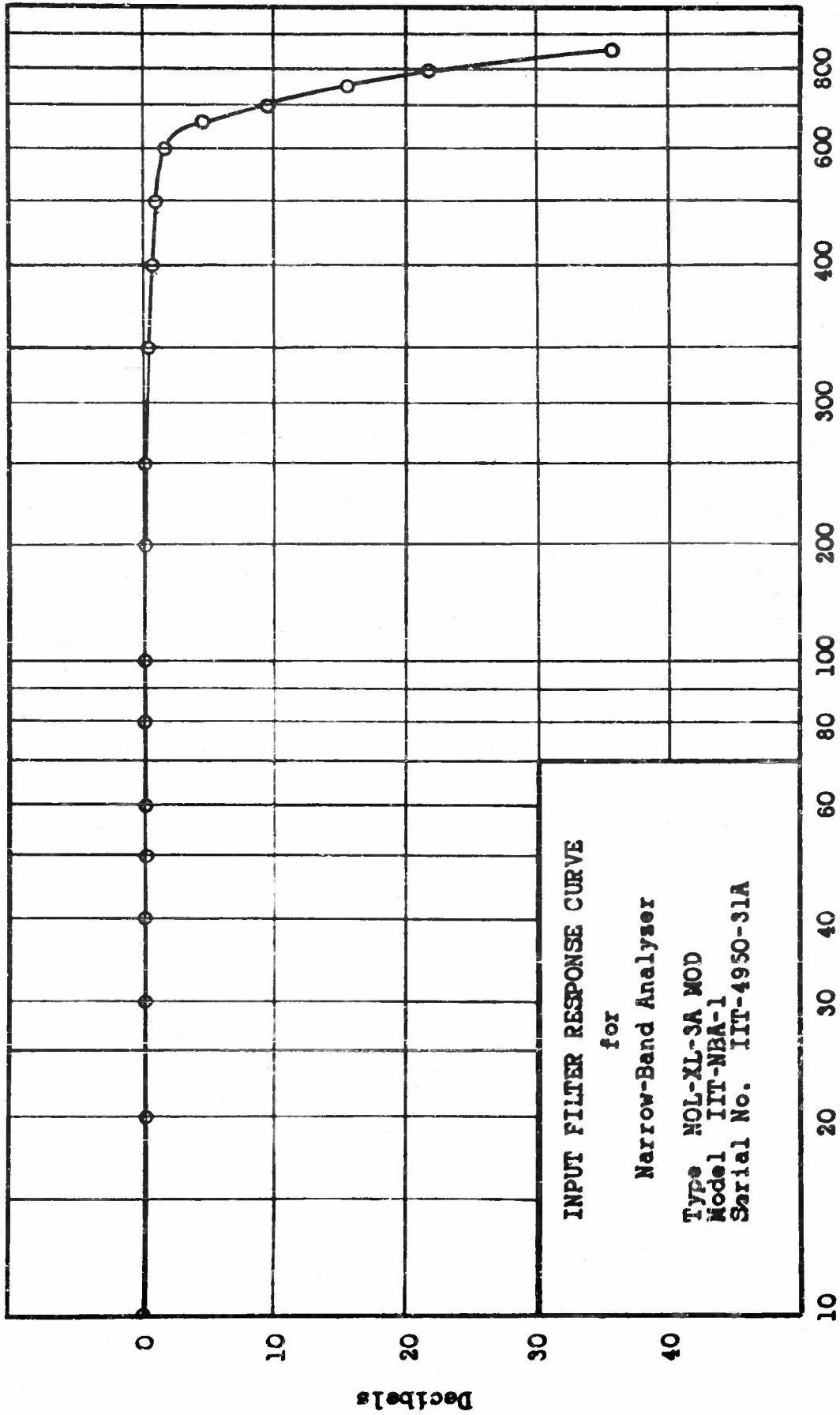

Fig. 8



INPUT FILTER RESPONSE CURVE
for
Narrow-Band Analyser
Type NOL-XL-3A MOD
Model IIT-NBA-1
Serial No. IIT-4950-31A

Fig. 9

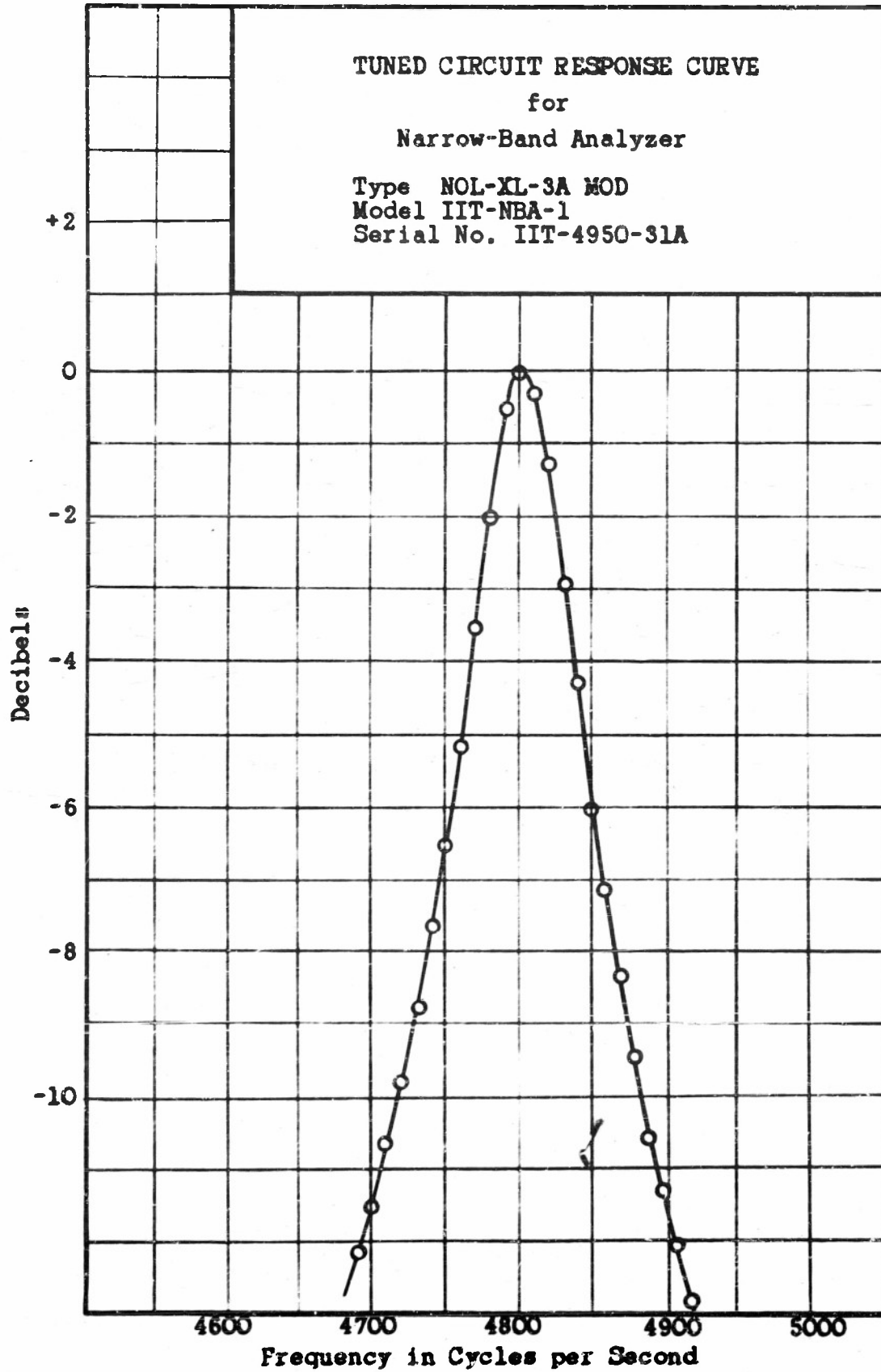

Fig. 10

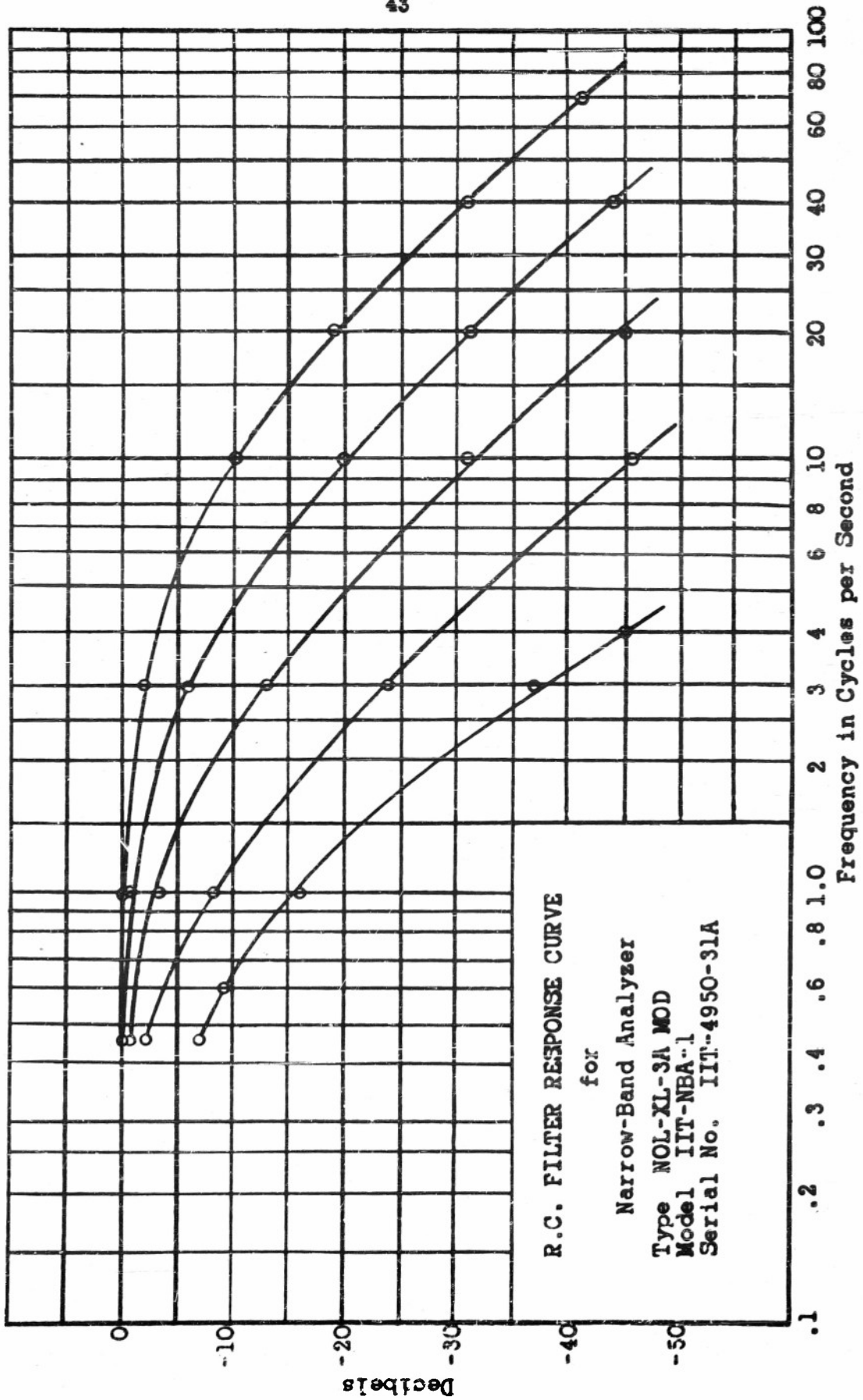
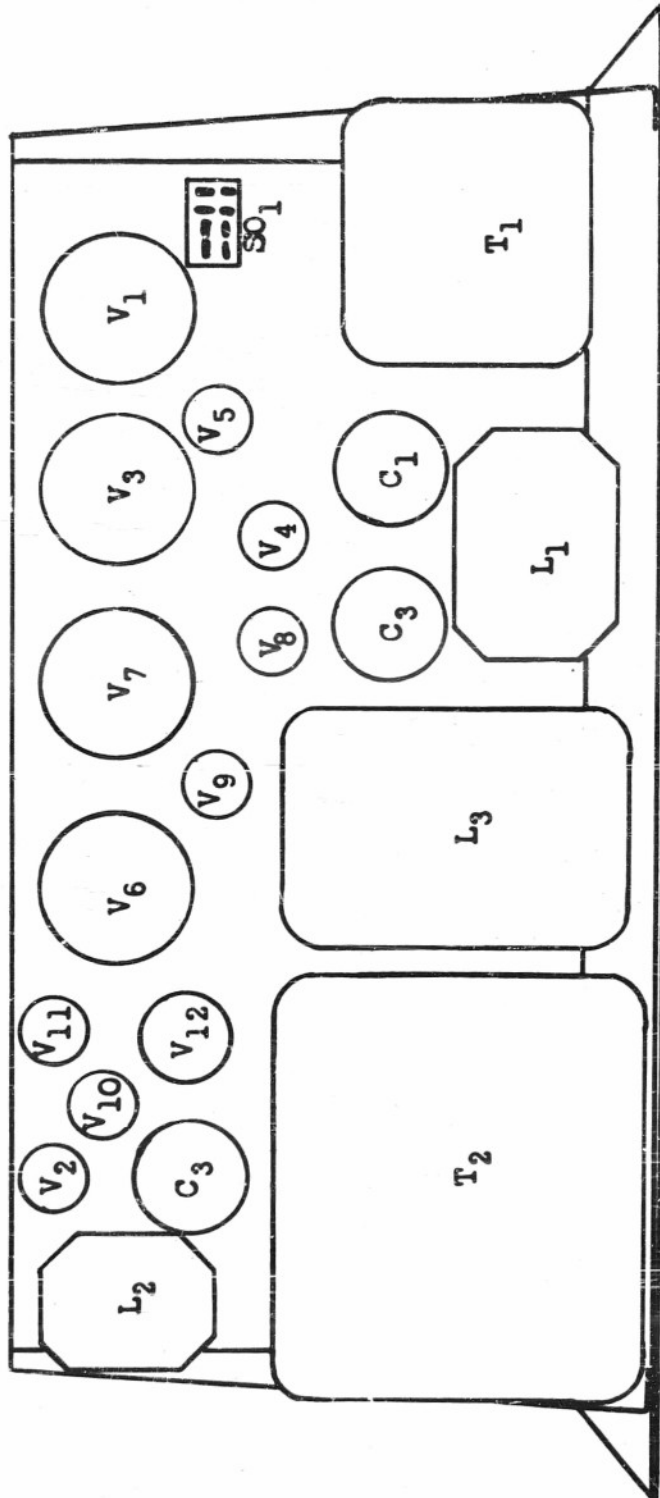

Fig. 11



Overlay Plate II
Power Supply Chassis

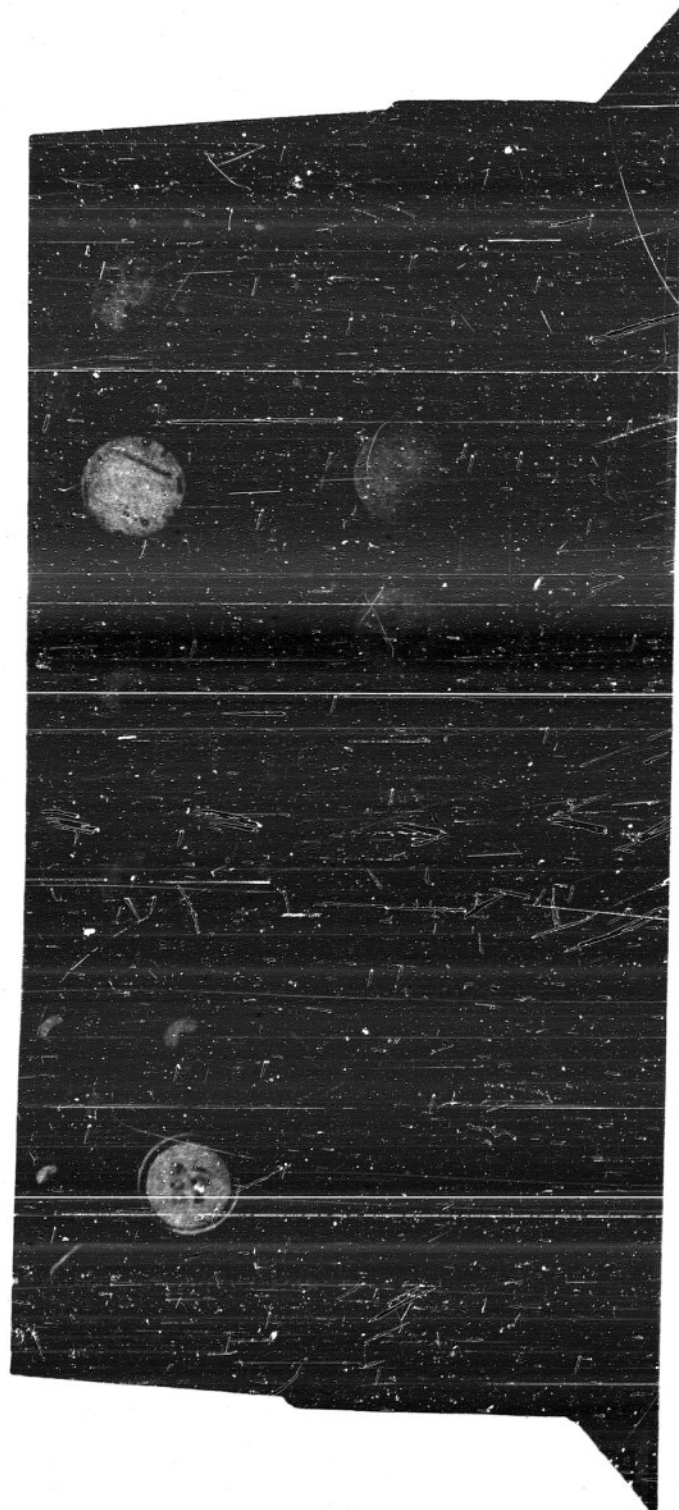
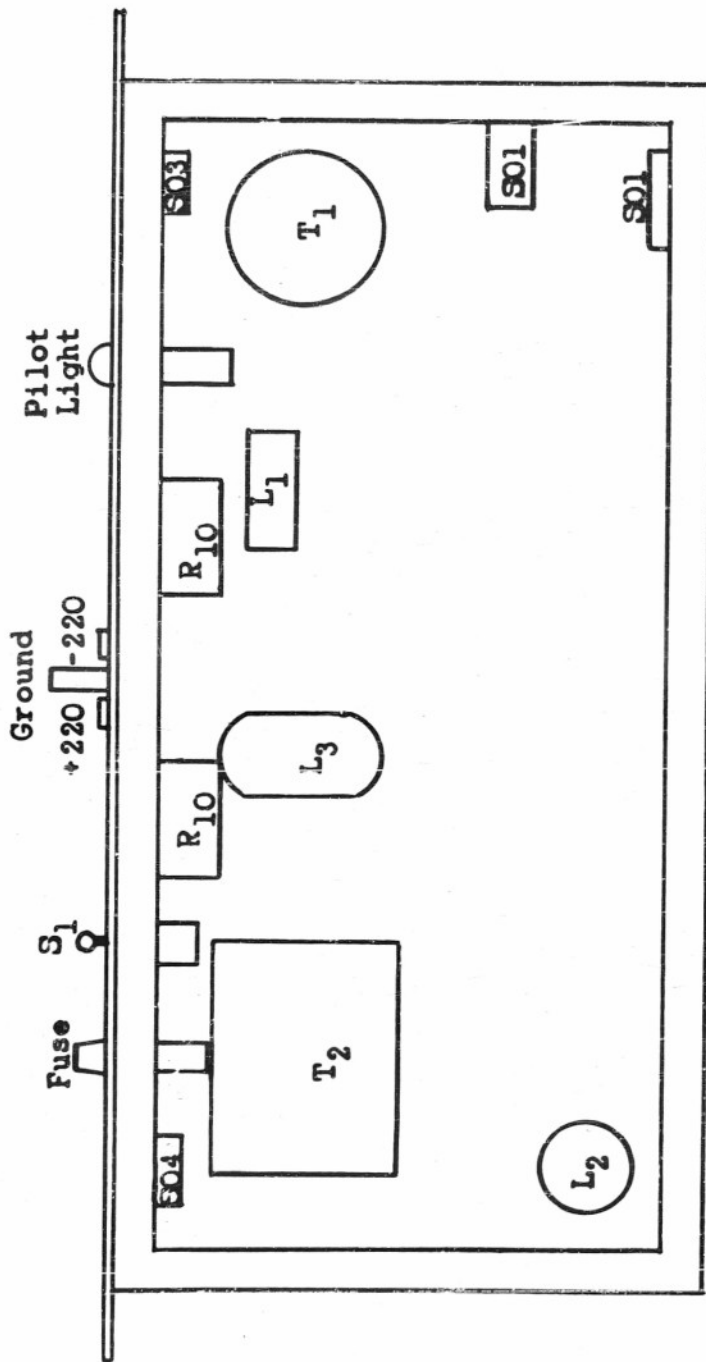

Plate II
Top View of Power Supply Chassis
Scale approximately 1 cm per in.



Overlay Plate III
Power Supply Chassis

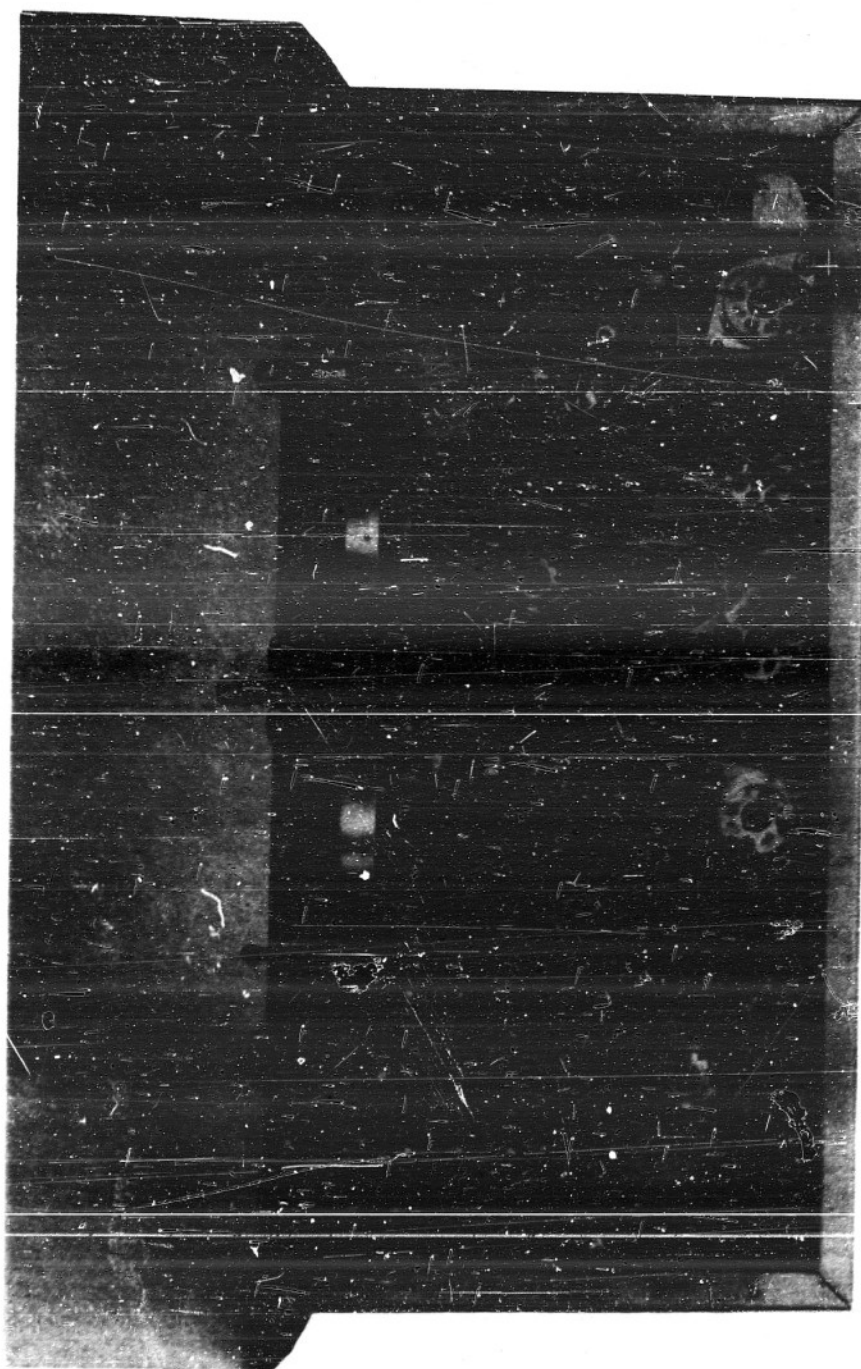
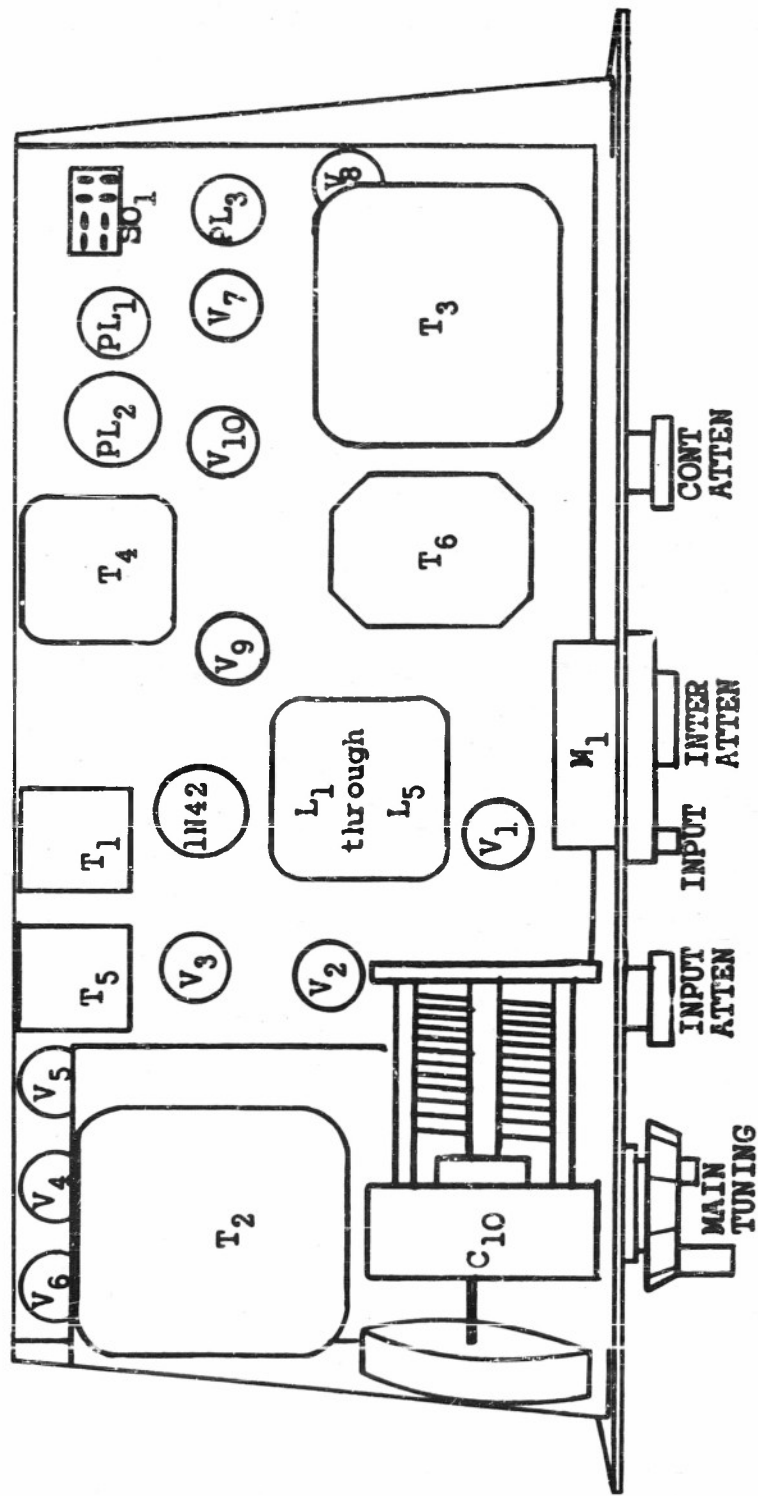

Plate III
Bottom View of Power Supply Chassis
Scale approximately 1 cm per in.



Overlay Plate IV

Chassis No. 1

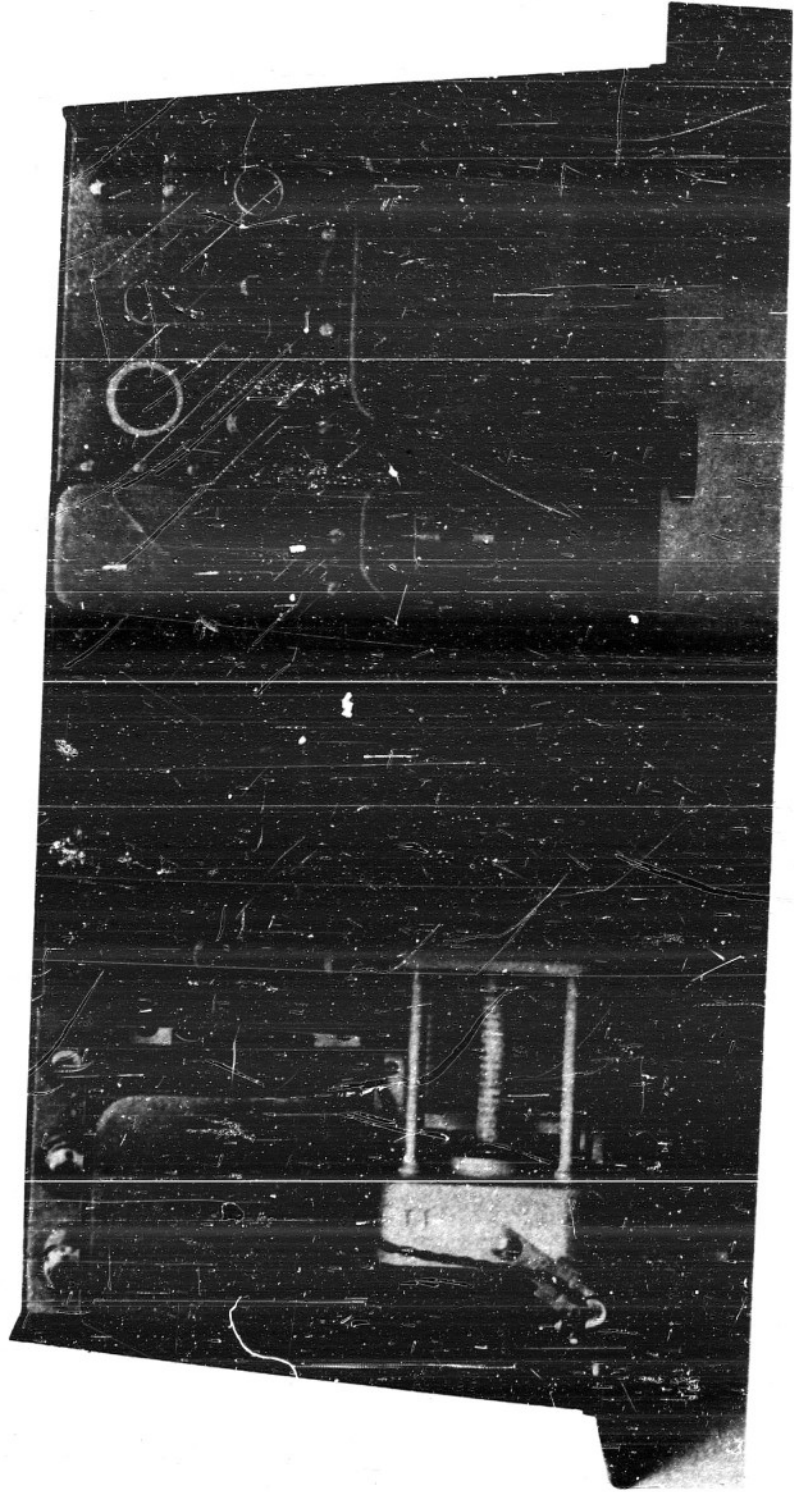
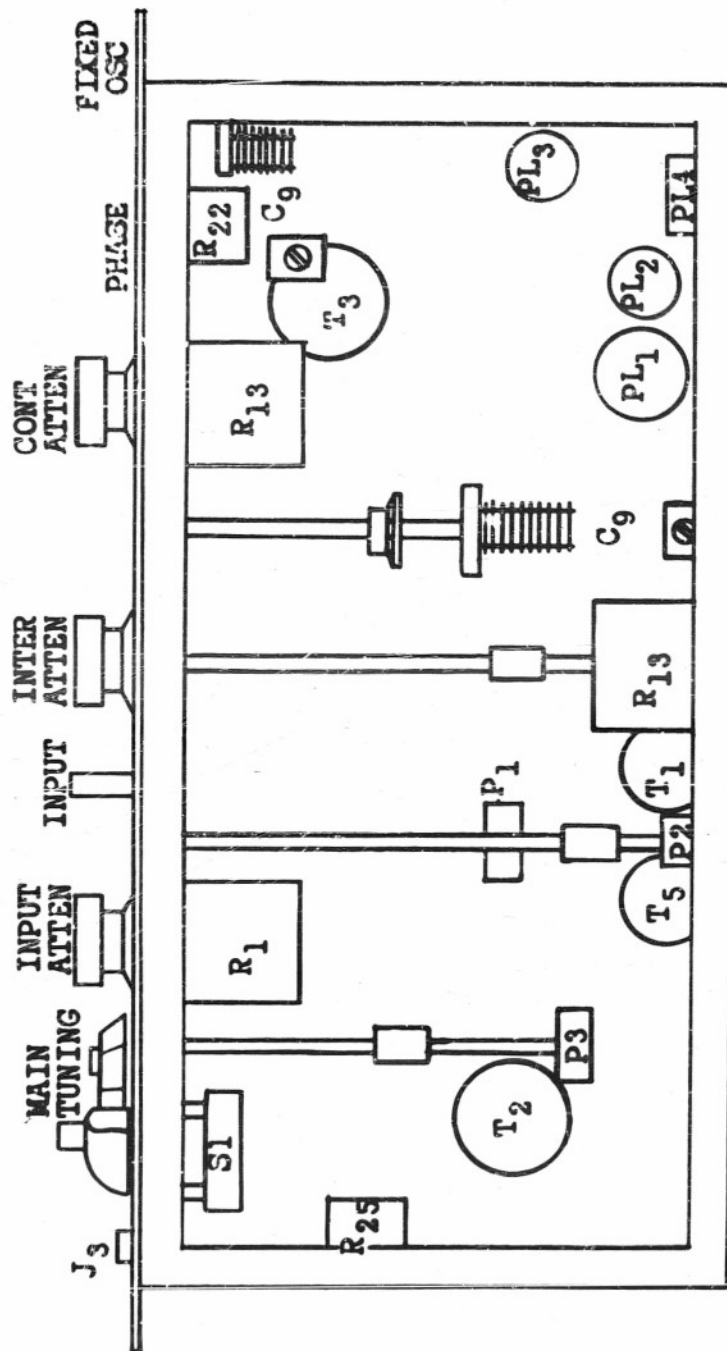

Plate IV
Top View of Chassis No. 1
Scale approximately 1 cm per in.



Overlay Plate V
Chassis No. 1

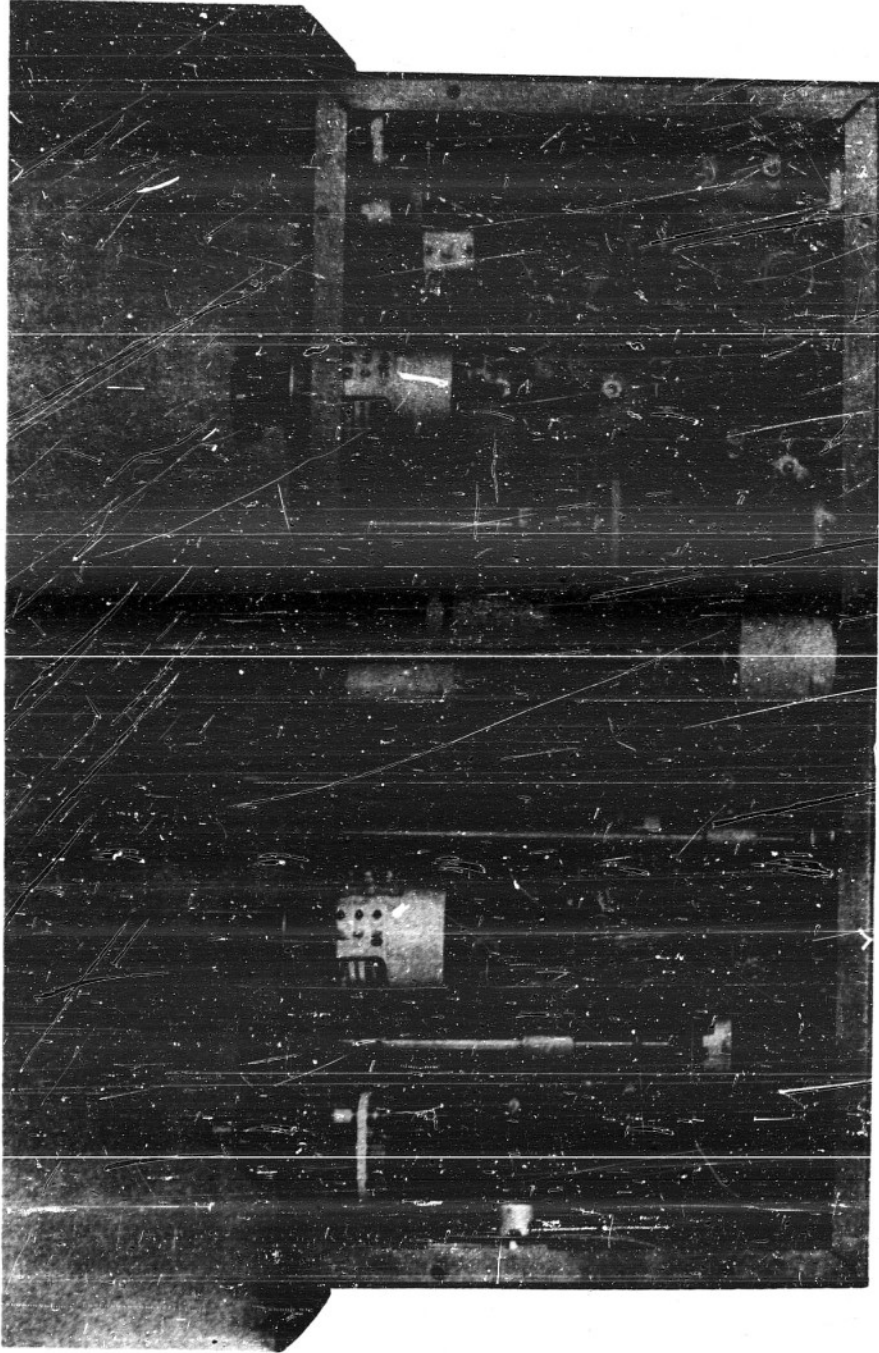
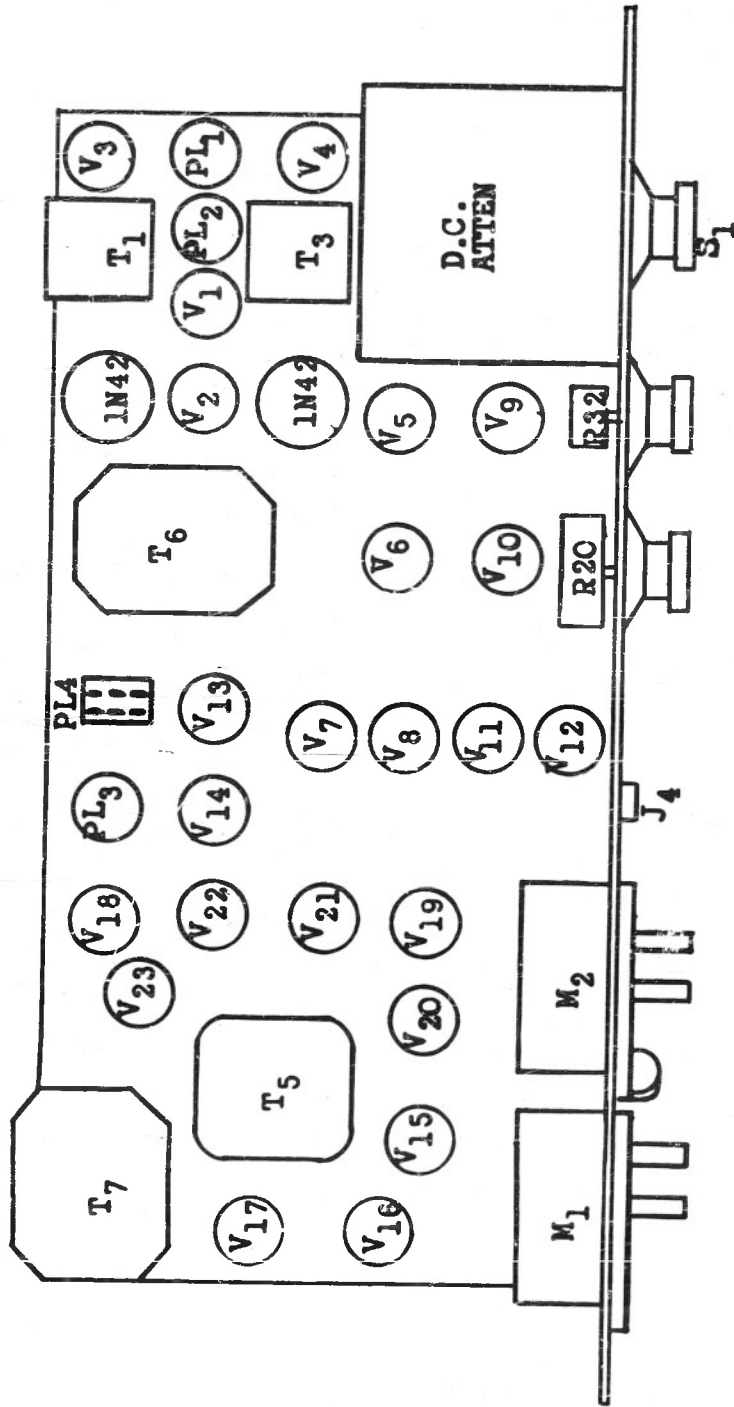

Plate V
Bottom View of Chassis No. 1
Scale approximately 1 cm per in.



Overlay Plate VI
Chassis No. 2

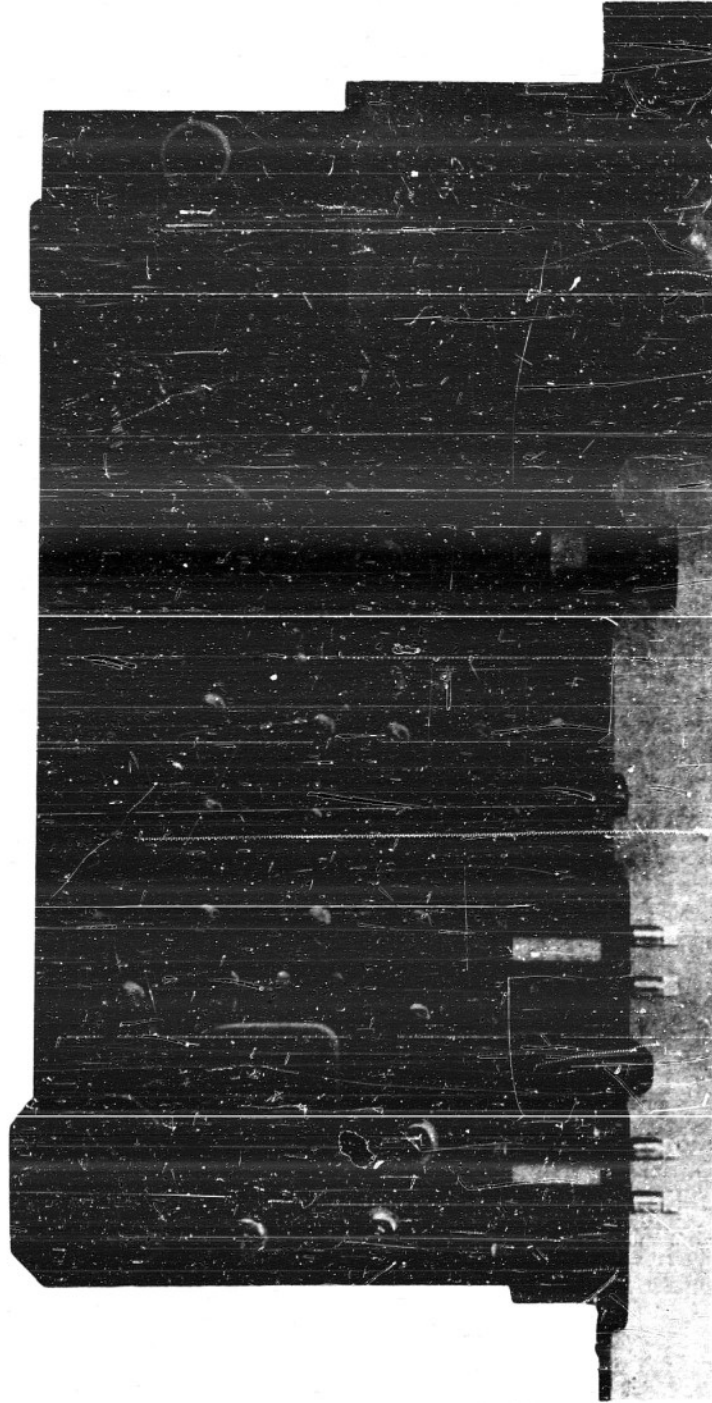
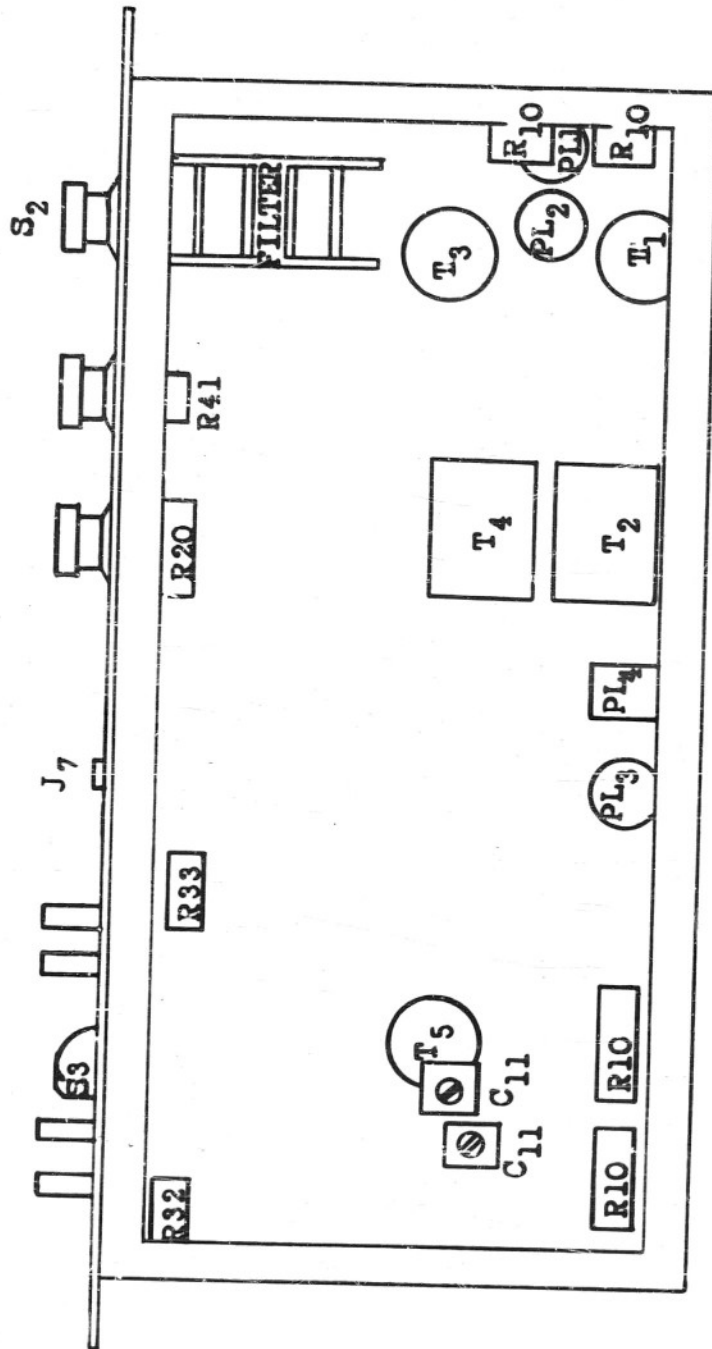

Plate VI
Top View of Chassis No. 2
Scale approximately 1 cm per in.



Overlay Plate VII
Chassis No. 2



Plate VII
Bottom View of Chassis No. 2
Scale approximately 1 cm per in.

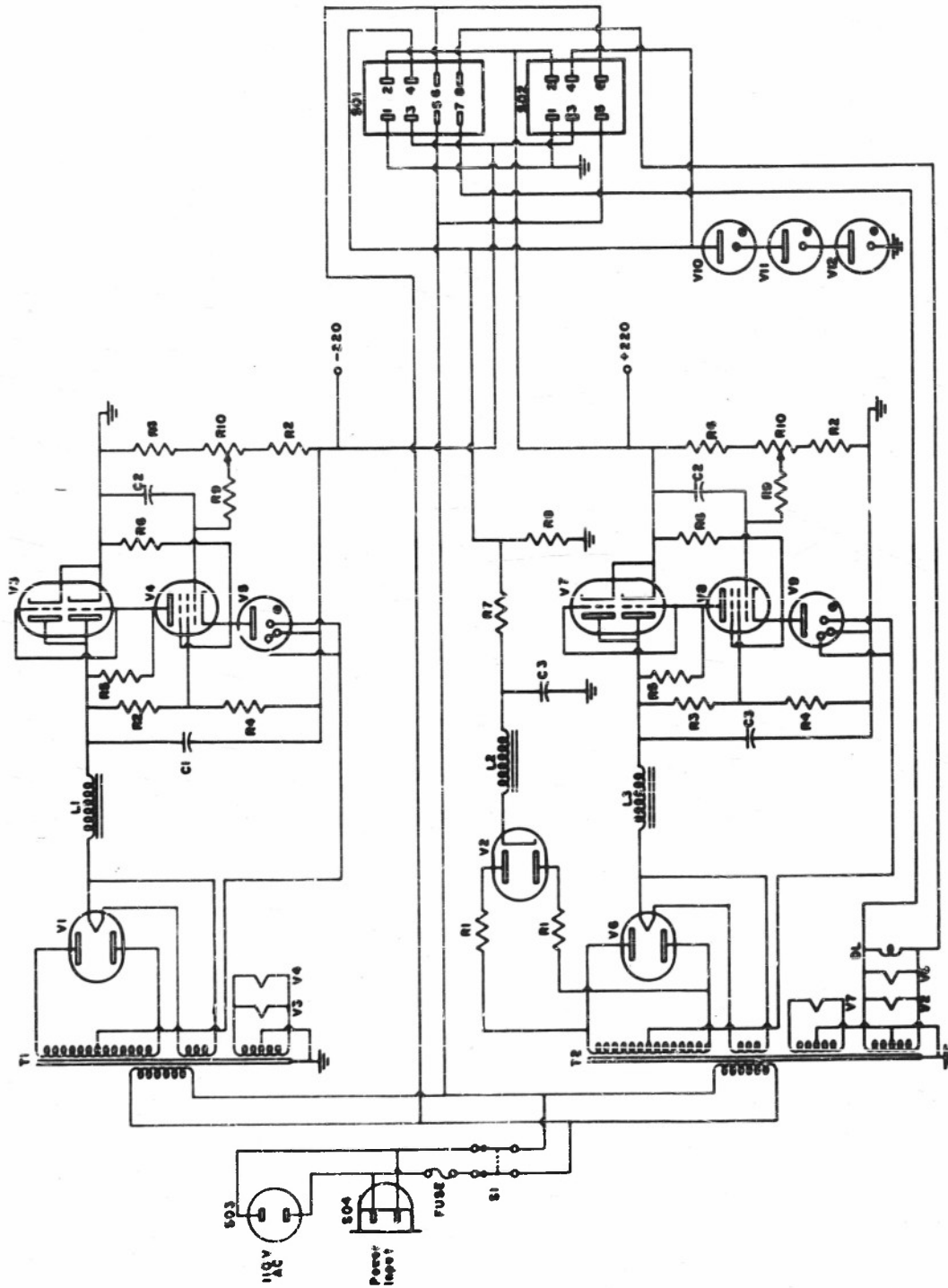

NARROW BAND ANALYZER
 TYPE NOL-XL-3A MOD.
 MODEL IIT-NBA-1
 SERIAL IIT-4950-31-A

POWER SUPPLY CHASSIS

Part List for Power Supply Chassis

<u>Part</u>	<u>Quantity</u>	<u>Description</u>
R ₁	2	1K 2w 10%
R ₂	3	33K 1w 10%
R ₃	1	22K 1w 10%
R ₄	2	100K 1w 10%
R ₅	2	220K 1w 10%
R ₆	4	56K 1w 10%
R ₇	1	5K 10w
R ₈	1	330K 1w 10%
R ₉	2	1 meg 1w 10%
R ₁₀	2	7.5K 4w ww potentiometer
C ₁	1	80 uf 450v plug in electrolytic
C ₂	2	1 uf 400v paper
C ₃	2	16 uf electrolytic
T ₁	1	CTC PSR 105 power transformer
T ₂	1	UTC S40 power transformer
L ₁	1	UTC S28 filter
L ₂	1	UTC S25 filter
L ₃	1	UTC S31 filter
SO ₁	1	Jones plug
SO ₂	1	Jones plug
SO ₃	1	Female AC socket
SO ₄	1	Male AC socket
DL	1	Pilot lamp
S ₁	1	DPDT switch
Fuse	1	3 amp 8AG

Part List for Power Supply Chassis - continued

V ₁ , V ₆	1 ea.	5R40Y
V ₂	1	6X4
V ₃ , V ₇	1 ea.	6AS70
V ₄ , V ₈	1 ea.	6AU6
V ₅ , V ₉	1 ea.	5651
V ₁₀	1	0A2
V ₁₁	1	0B2
V ₁₂	1	0A3

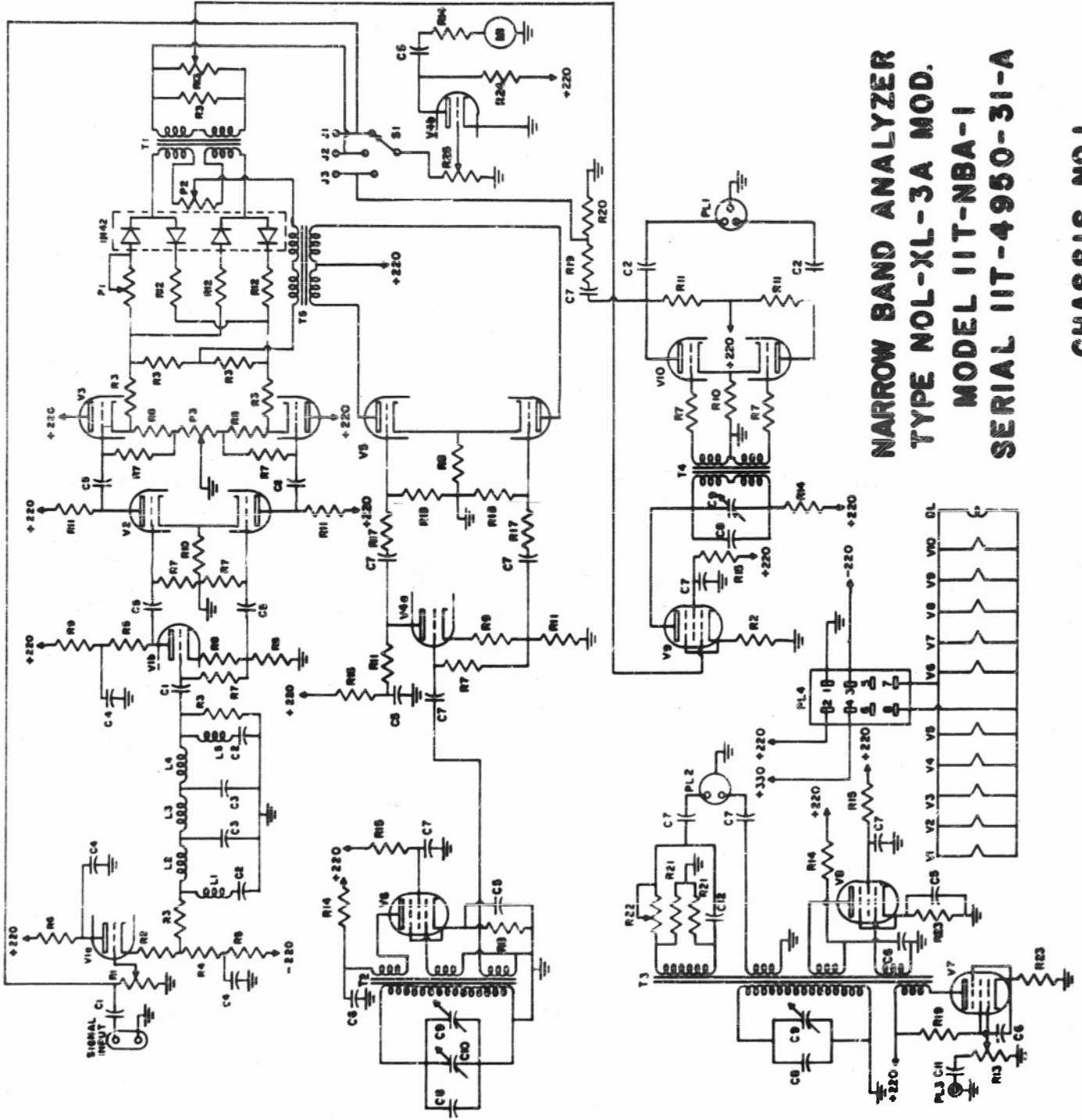

NARROW BAND ANALYZER
TYPE NOL-XL-3A MOD.
MODEL IIT-NBA-1
SERIAL IIT-4950-31-A

CHASSIS NO.1

Part List for Chassis No. 1

<u>Part</u>	<u>Quantity</u>	<u>Description</u>
R ₁	1	250K Daven attenuator CP-353-X
R ₂	2	390 ohm 1/2w 10%.
R ₃	6	1K 1/2w 10%
R ₄	1	27K 1w 10%
R ₅	3	10K 1/2w 10%
R ₆	1	12K 1/2w 10%
R ₇	8	470K 1/2w 10%
R ₈	6	470 ohm 1/2w 10%
R ₉	1	3.3K 1/2w 10%
R ₁₀	2	270 ohm 1/2w 10%
R ₁₁	7	15K 1/2w 10%
R ₁₂	3	220 ohm 1/2w matched to 2%
R ₁₃	2	50K Daven attenuator CP-353-S
R ₁₄	4	22K 1/2w 10%
R ₁₅	3	220K 1/2w 10%
R ₁₆	1	33K 1w 10%
R ₁₇	2	15K 1/2w 10%
R ₁₈	2	100K 1/2w 10%
R ₁₉	2	270K 1/2w 10%
R ₂₀	1	39K 1/2w 10%
R ₂₁	2	47K 1/2w 10%
R ₂₂	1	250K potentiometer
R ₂₃	2	1.5K 1/2w 10%
R ₂₄	1	47K 1w 10%
R ₂₅	1	0.5 meg potentiometer
P ₁	1	500 ohm potentiometer

Part List for Chassis No. 1 - continued

P ₂	1	100 ohm potentiometer
P ₃	1	25K potentiometer
C ₁	2	2.0 uf 200v
C ₂	4	0.05 uf 200v
C ₃	2	0.25 uf 200v
C ₄	3	20 uf 250v elec.
C ₅	8	1.0 uf 400v
C ₆	3	0.5 uf 400v
C ₇	9	0.1 uf 400v
C ₈	3	Adjust to resonate
C ₉	3	Adjust to resonate
C ₁₀	1	21 uuf ± 1-1/2 to 220 uuf ± 3 tuning capac.
C ₁₁	1	0.002 uf mica.
C ₁₂	1	330 uuf mica.
T ₁ , T ₂ , T ₃ , T ₄	1 ea.	Special transformer, see p. 66
L ₁ , L ₂ , L ₃ , L ₄ , L ₅	1 ea.	Special inductor, see p. 66
M ₁	1	0-1 Triplett Mod. 327-T, 2000 ohms per volt
S ₁	1	1 pole, 3 pos. rotary
PL ₁	1	Carrier signal output
PL ₂	1	Oscillator signal output
PL ₃	1	Control signal output
PL ₄	1	Power input
V ₁ , V ₂ , V ₃ , V ₄ , V ₁₀	1 ea.	2C51
V ₅	1	6J6
V ₆ , V ₈	1	6AK5
V ₇ , V ₉	1	6AU6
DL	1	Dial lamp 250 ma.

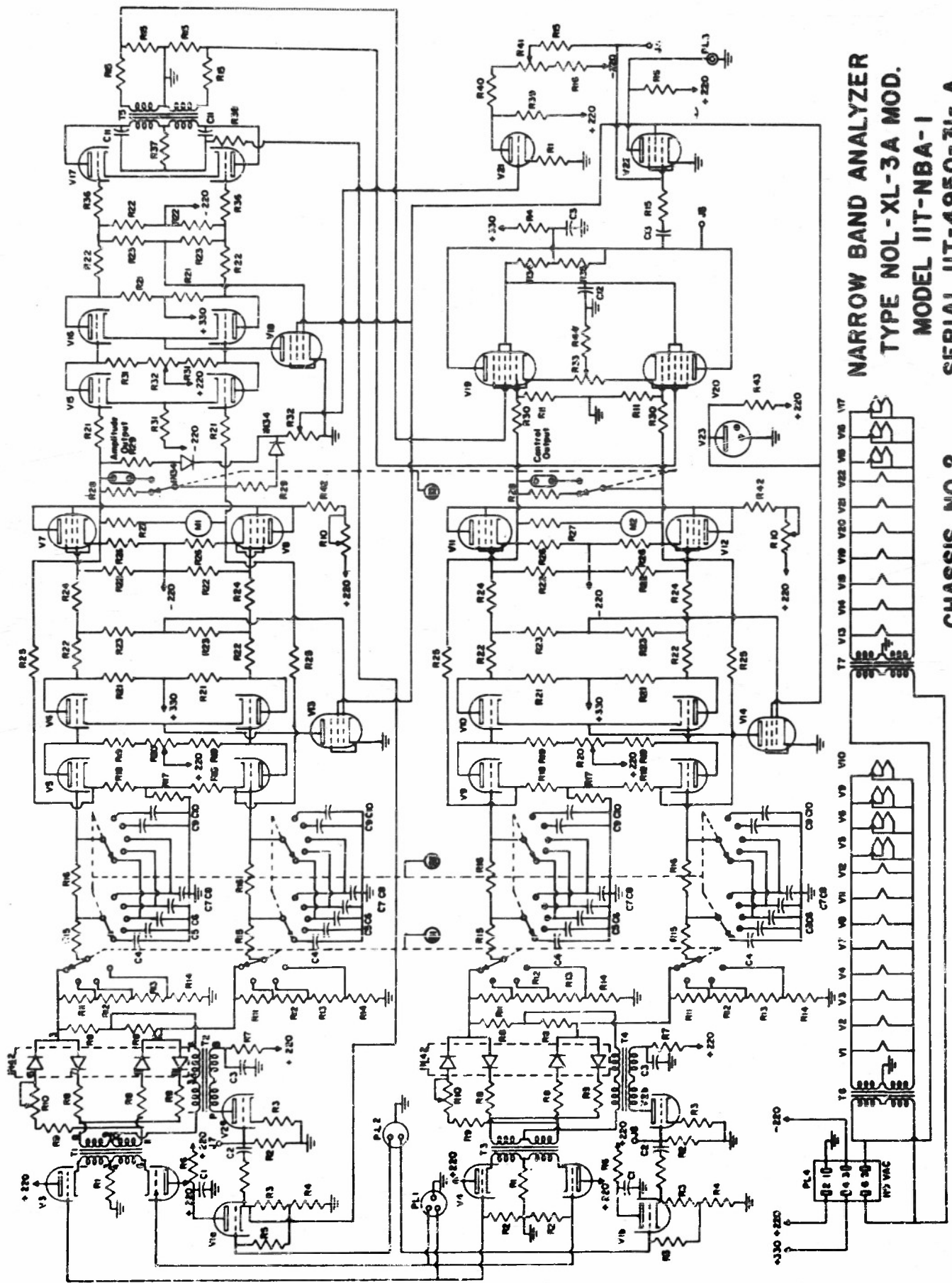

NARROW BAND ANALYZER
TYPE NOL-XL-3A MOD.
MODEL IIT-NBA-1
SERIAL IIT-4950-3I-A

CHASSIS NO.2

Part List for Chassis No. 2

<u>Part</u>	<u>Quantity</u>	<u>Description</u>
R ₁	3	390 ohm 1/2w 10%
R ₂	2	56K 1/2w 10%
R ₃	2	680 ohm 1/2w 10%
R ₄	3	15K 1w 10%
R ₅	3	470K 1/2w 10%
R ₆	3	6.8K 1/2w 10%
R ₇	2	3.3K 1w 10%
R ₈	10	470 ohm 1/2w two sets of five matched within 2%
R ₉	2	220 ohm 1/2w 10%
R ₁₀	4	500 ohm potentiometer
R ₁₁	6	6.8K 1/2w 1%
R ₁₂	4	2.15K 1/2w 1%
R ₁₃	4	680 ohm 1/2w 1%
R ₁₄	4	314 ohm 1/2w 1%
R ₁₅	10	100K 1/2w 10%
R ₁₆	5	390K 1/2w 10%
R ₁₇	2	1.5K 1/2w 10%
R ₁₈	4	330 ohm matched 1%
R ₁₉	4	250K prec. 1%
R ₂₀	2	70K ww potentiometer
R ₂₁	6	150K 1/2w 10%
R ₂₂	12	680K 1/2w three sets of four matched within 1%
R ₂₃	6	1.8 meg 1/2w 10%
R ₂₄	4	11.1K 1/2w 1%
R ₂₅	4	100K 1/2w 1%

Part List for Chassis No. 2 - continued

R ₂₆	4	15K 10w ww
R ₂₇	2	68K 1/2w 10%
R ₂₈	2	1.5K 1w 10%
R ₂₉	2	33K 1/2w 10%
R ₃₀	2	82K 1/2w 1%
R ₃₁	3	270K 1/2w 10%
R ₃₂	2	10K potentiometer
R ₃₃	1	100 ohm potentiometer
R ₃₄	1	27K 1w 10%
R ₃₅	1	47K 1w 10%
R ₃₆	2	1 meg 1/2w 10%
R ₃₇	1	150 ohm 1/2w 10%
R ₃₈	1	15K 1/2w 10%
R ₃₉	1	22K 1w 10%
R ₄₀	1	220K 1/2w 10%
R ₄₁	1	50K potentiometer
R ₄₂	2	2.8K 5w
R ₄₃	1	6.8K 2w
C ₁	2	0.25 uf 400v
C ₂	2	0.1 uf 400v
C ₃	3	1.0 uf 400v
C ₄	4	4.0 uf 200v
C ₅	4	2.0 uf 200v
C ₆	4	1.0 uf 200v
C ₇	4	0.5 uf 200v
C ₈	4	0.25 uf 220v
C ₉	4	0.1 uf 220v
C ₁₀	4	0.05 uf 220v

Part List for Chassis No. 2 - continued

C ₁₁	1	0.0044 uf mica.
C ₁₂	1	560 uuf mica.
T ₁ , T ₃	1 ea.	UTC A20
T ₂ , T ₄	1 ea.	UTC A25
T ₅	1	Special, see p. 66
T ₆ , T ₇	1 ea.	UTC S55
M ₁ , M ₂	1 ea.	500-0-500 ua, Simpson Mod. 27
S ₁	1	4 pole, 4 pos. rotary
S ₂	1	8 pole, 5 pos. rotary
S ₃	1	DPDT toggle
PL ₁	1	Carrier signal input
PL ₂	1	Oscillator signal input
PL ₃	1	Control signal output
PL ₄	1	Power input
V ₁ , V ₂ , V ₃ , V ₄	1 ea.	2C51
V ₅ , V ₆ , V ₉ , V ₁₀ V ₁₅ , V ₁₆ , V ₁₇	1 ea.	12AX7
V ₇ , V ₈ , V ₁₁ , V ₁₂	1 ea.	6AK6
V ₁₃ , V ₁₄ , V ₁₈	1 ea.	6AV6
V ₁₉ , V ₂₀	1 ea.	6BE6
V ₂₁	1	6AB4
V ₂₂	1	6BJ6
V ₂₃	1	OB2

SPECIFICATIONS FOR SPECIAL INDUCTORS AND TRANSFORMERS

Transformer T₂ Core: 2 W.E. #475966 cores paralleled

B	Tank	Coil A	2050t	#26 enamel	(L app. 1.22h)
	Plate	Coil B	40t	#32	"
	Grid	Coil C	20t	#32	"
C	Output	Coil D	125t	#32	"

Insulating tape between Coil A, B, C and D.
Potted in metal can.

Transformer T₄ Core: W.E. #478438

Pri. Winding: 516t #26 enamel C.T.
Seco. Winding: 200t #32 enamel C.T.

Potted in metal can.

Transformer T₅ Core: W.E. #467585

Pri. - 2000t #32 enamel C.T. - Wound by doubling wire and winding two halves of primary simultaneously.
Seco. - 400t #32 enamel C.T.

Potted in metal can.

Transformer T₈ Core: 2 W.E. #475966 cores paralleled

Tank	Coil A	- 775t	#22 enamel
Feedback	Coil B	- 150t	#31
Plate	Coil C	- 100t	#30
Grid	Coil D	- 20t	#26
Output	Coil E	- 45t	#30
Output	Coil F	- 90t	#30

Coil A insulated from other windings by layer of glass tape.
Potted in metal can.

Filter Coils

L ₁	: W.E. #467585 core	- app. 2500t	#32 enamel	(0.533h)
L ₂	"	"	"	(0.8h)
L ₃	"	"	"	(1.0h)
L ₄	"	"	"	(0.8h)
L ₅	"	"	"	(0.533h)

All components mounted in single can and potted.

SCHEMATIC AND PART LIST CORRECTIONS

The 1N42's used in the ring modulators were omitted from the part lists. One is used on Chassis No. 1 and two on Chassis No. 2.

Schematic and Part List for Chassis No. 1

1. The filament circuit is incorrect. Filament transformer T_6 (UTC S55) is not shown on the schematic. (See Plate IV). The power supply chassis transformer T_2 supplies filament voltage to V_7 through V_{10} through terminals 7 and 8 of PL_4 . Voltage for V_1 through V_6 and the dial light DL is supplied by T_6 (UTC S55). Primary voltage for T_6 is obtained from terminals 5 and 6 of PL_4 .
2. One watt resistors are used for R_{11} .
3. T_1 is a UTC A20 transformer.
4. T_5 is a UTC A26 transformer.
5. V_6 and V_8 are 6AU6 vacuum tubes although the 6AX5 type works.

Schematic and Part List for Chassis No. 2

1. R_{10} in the plate circuits of V_7 , V_8 , V_{11} and V_{12} are 500 ohm Mallory type M500P units.
2. R_{10} in the 1N42 modulator circuits are 500 ohm Ohmite type AB composition units.
3. R_3 on the cathodes of V_2 have been changed to 220 ohms $\frac{1}{2}w$ and should be labeled R_9 . Four R_9 's are required.
4. The unnumbered resistors shown between the cathodes of V_1 and the grids of V_2 have been omitted.
5. The cathodes of V_{17} are returned directly to ground.
6. R_{32} should read 2 100K potentiometers.
7. R_{44} is 470 ohm $\frac{1}{2}w$ 10%.
8. C_{13} is 0.1 ufd 400v.
9. V_{13} , V_{14} , V_{18} should read 6AU6.

APPENDIX B

DISTRIBUTION LIST

Office of Naval Research Washington 25, D. C. Attn: Code 466	(3)	Commander Design Division, Philadelphia Naval Shipyard, Naval Base Philadelphia, Pennsylvania	(1)
Code 421	(1)		
Code 424	(1)		
Code 429	(1)	Commander Boiler and Turbine Laboratory Philadelphia Naval Shipyard Naval Base	
Code 438	(1)	Philadelphia, Pennsylvania	(1)
Armed Services Technical Information Agency Documents Service Center Knott Building Dayton 2, Ohio	(5)	Commander Boston Naval Shipyard Boston 28, Massachusetts	(1)
Office of Technical Services Department of Commerce Washington 25, D. C.	(1)	Commander Charleston Naval Shipyard Naval Base Charleston, South Carolina	(1)
Director, Naval Research Laboratory Technical Information Officer Washington, D. C. (Further distribution to be made by NRL Code 2000 to B.J.S.N. and Canadian Joint Staff)	(6)	Commander Portsmouth Naval Shipyard Portsmouth, New Hampshire	(1)
Chief, Bureau of Ships Department of the Navy Washington 25, D. C. Attn: Code 300	(1)	Commander Pearl Harbor Naval Shipyard Navy No. 128 Fleet Post Office San Francisco, California	(1)
Code 344	(1)		
Code 371	(1)	Commander Puget Sound Naval Shipyard Bremerton, Washington	(1)
Code 430	(1)		
Code 436	(1)		
Code 490	(1)		
Code 512	(1)	Commander New York Naval Shipyard Naval Base Brooklyn 1, New York	(1)
Code 513	(1)		
Code 515	(1)		
Code 517	(1)		
Code 541	(1)	Commander Long Beach Naval Shipyard Long Beach, California	(1)
Code 543	(1)		
Commander Marine Island Naval Shipyard Vallejo, California	(1)	Commander Norfolk Naval Shipyard Portsmouth, Virginia	(1)
Commander Materials Lab, New York Naval Shipyard, Naval Base Brooklyn 1, New York	(1)	Commander San Francisco Naval Shipyard San Francisco, California	(1)

Distribution List - continued

Commander Mare Island Naval Shipyard (Rubber Laboratory) Vallejo, California	(1)	Chief, Reports Group Jet Propulsion Laboratory California Institute of Technology 4800 Oak Grove Drive Pasadena 3, California	(1)
Commanding Officer U. S. Naval Submarine Base Havy No. 128 Fleet Post Office San Francisco, California	(1)	U. S. Department of Commerce National Bureau of Standards Van Ness Street & Conn. Avenue Washington, D. C.	(1)
Commanding Officer U. S. Naval Submarine Base New London, Connecticut	(1)	Supervisor of Shipbuilding USN and Naval Inspector of Ordnance Electric Boat Company Groton, Connecticut	(1)
Commanding Officer U. S. Naval Air Station Lakehurst, N. J.	(1)	Office of Naval Research Branch Office 150 Causeway Street Boston, Massachusetts	(1)
Commanding Officer U. S. Naval Ordnance Laboratory White Oak, Maryland Attn: Mr. B. Snavely	(1)	Office of Naval Research Branch Office Tenth Floor The John Crerar Library Building 86 East Randolph Street Chicago 1, Illinois	(1)
Commanding Officer and Director U. S. Navy Underwater Sound Lab. Fort Trumbull New London, Connecticut	(1)	Office of Naval Research Branch Office 346 Broadway New York 13, N. Y.	(1)
Director David Taylor Model Basin Washington 7, D. C.	(1)	Office of Naval Research Branch Office 1030 E. Green Street Pasadena 1, California	(1)
Director U. S. Navy Engineering Experiment Station Annapolis, Maryland	(1)	Office of Naval Research Branch Office 1000 Greary Street San Francisco 9, California	(1)
Director U. S. Navy Electronics Lab. San Diego, California	(1)	Officer-in-Charge Office of Naval Research Navy #100 Fleet Post Office New York, N. Y.	(2)
Bureau of Aeronautics Department of the Navy Washington 25, D. C. Attn: Mr. Crowley	(1)		
Chief, Bureau of Ordnance Re6 Department of the Navy Washington 25, D. C.	(2)		

Distribution List - continued

University of Michigan
Engineering Research Institute
Ann Arbor, Michigan
Attn: Dr. P. H. Geiger (1)

General Electric Company
General Engineering & Consulting Lab.
Schenectady, New York
Attn: Dr. R. Fehr
Via: Navinspec of Ord, G.E. Co.,
Schenectady, N. Y. (1)

Hudson Laboratory
Columbia University
145 Palisade Street
Dobbs Ferry, New York (1)

Commander
Submarine Development Group Two
Box 70 U.S. Naval Submarine Base
New London, Connecticut
Attn: Lt. O. B. Nelson, USN (1)