

UNCLASSIFIED

AD NUMBER

AD016658

CLASSIFICATION CHANGES

TO: unclassified

FROM: confidential

LIMITATION CHANGES

TO:  
Approved for public release; distribution is unlimited.

FROM:  
Controlling DoD Organization: Office of the Chief of Ordnance, Washington, DC.

AUTHORITY

Army Armament R&D Command ltr dtd 4 Sep 1981;  
Army Armament R&D Command ltr dtd 4 Sep 1981

THIS PAGE IS UNCLASSIFIED

**CONFIDENTIAL**

**THIRTIETH  
PROGRESS REPORT  
OF  
THE FIRESTONE TIRE & RUBBER CO.  
ON  
105 MM BATTALION ANTI-TANK PROJECT**

**Contract No.  
DA-33-019-ORD-33 (Negotiated)  
RAD ORDTS 1-12383**

**THE FIRESTONE TIRE & RUBBER CO.  
Defense Research Division  
Akron, Ohio  
JANUARY, 1953**

**CONFIDENTIAL**

## INDEX

	Page
I. Abstract .....	1
II. The Weapon System .....	2
III. T138 Projectile .....	5
IV. T119 Projectile .....	6
V. Penetration Studies .....	10
VI. Fuzes .....	15

# CONFIDENTIAL

## ABSTRACT

An inventory of recoilless rifles and mounts manufactured by Firestone for the BAT and ONTOS projects is presented.

The peak pressure has been measured at each of several stations in the T137E1 rifle. Both copper and piezo gages were used. The test results are presented and discussed.

A program for the further development of the T138 projectile, involving long range accuracy tests, is proposed.

Determination of the strength of the component parts of the T119 projectile has continued. Tests of the piston of the fin opening mechanism are described. Planning is given for the investigation of four phases of the T119 projectile development - length of projectile, number and size of fins, fuze and howitzer firing. An accounting of projectile shipments is presented.

Two important phases of penetration studies were investigated: Test data showing the effect of a fuze wire on the liner axis are reported and discussed. The study of the effect of interior tee configuration on penetration was continued and the test results are discussed.

Safety tests on the T222E5 base elements were conducted by Picatinny Arsenal. None of them armed or suffered any damage. A switch for the T267 superquick and delay fuze is illustrated and described. Tests were conducted to compare the voltage output of two nose element designs, and functioning tests were conducted with one. The results are presented. Tests were conducted to determine the applicability of a selenium rectifier and a condenser in a setback-actuated electric fuze for a proposed HEAT shell arrangement. The test results are given.

# CONFIDENTIAL

## THE WEAPON SYSTEM

An inventory of recoilless rifles and mounts manufactured by Firestone for the BAT and ONTOS projects is presented in Table I.

**Table I**  
**Inventory of Recoilless Rifles and Mounts**  
**Manufactured by Firestone for BAT and ONTOS Projects**

Rifle or Mount	Location	Comments
<u>T137E3 Rifles</u>		
Ser. No. 1	Akron	Returned from Fort Benning
2	Akron	Returned from Fort Benning
3	Allis-Chalmers	T165 Serial No. 5
4	Allis-Chalmers	T165 Serial No. 7
5	Allis-Chalmers	Shipped 1-17-53
6	Allis-Chalmers	T166 Serial No. 2
7	Allis-Chalmers	T165 Serial No. 6
8	Allis-Chalmers	T165 Serial No. 5
9	Allis-Chalmers	T165 Serial No. 6
10	Allis-Chalmers	T166 Serial No. 3
11	Allis-Chalmers	T165 Serial No. 7
12	Not Completed	
13	Aberdeen Proving Ground	BAT Engineering Test
14	Akron	Proofed and ready for shipment to Allis-Chalmers
15	Allis-Chalmers	Shipped 1-17-53
16-25, incl.	Not Completed	
<u>T137E2 Rifles</u>		
Ser. No. 1	Akron	Used for spare parts
2	"	E. O. D. for test facility.
<u>T137E1 Rifles</u>		
Ser. No. 1	Akron	To be salvaged
2	Akron	" " "
3	Akron	" " "
4	Watertown Arsenal	To be returned to Firestone on completion of metallurgical study.
5	Akron	To be salvaged
6	"	" " "
7	"	" " "
8	"	" " "
<u>T137 Rifle</u>		
Ser. No. 1	Akron	Destroyed in proofing
<u>T152E5 Mounts</u>		
Ser. No. 1	Akron	
2	Akron	
3	Aberdeen Proving Ground	BAT Engineering Test
<u>T152E4 Mounts</u>		
Ser. No. 1	Allis-Chalmers	T165 Serial No. 5
2	Allis-Chalmers	T165 Serial No. 6
3	Allis-Chalmers	T166 Serial No. 2
4	Allis-Chalmers	T166 Serial No. 3
5	Allis-Chalmers	T165 Serial No. 7
6	Allis-Chalmers	Shipped 1-17-53
7	Akron	Proofed and ready for shipment to Allis-Chalmers
8-12, incl.	Not Completed	
<u>T152E3 Mounts</u>		
Ser. No. 1	Akron	To be salvaged
2	Akron	Converted to E4
3	Akron	Converted to E4
4	Akron	To be salvaged
<u>T152E2 Mounts</u>		
Ser. No. 1	Akron	To be salvaged
2	Akron	Salvaged
<u>T152E1 Mount</u>		
Ser. No. 1	Akron	Salvaged
<u>T152 Mount</u>		
Ser. No. 1	Akron	Salvaged

# CONFIDENTIAL

## Pressure Distribution, T137E1 Rifle

Nine pressure stations were installed in a T137E1 rifle; four were located in the chamber and five in the tube, as shown in Fig. 1. The pressure distribution in the rifle was obtained, using both copper and piezo gages. Pressure readings were also obtained using M-3 type internal pressure gages. To insure that the external copper pressure gages were operating in the proper range of copper deformation, two gages were used on each round, one having a piston area of  $1/6$  sq in and the other an area of  $1/15$  sq in. The two external copper pressure gages and the piezo gage were cycled so that each gage was at each station for at least one round. The charge used was 8 lb 1 oz of M10, MP, .0335-in web powder. Projectiles were 17.5 lb slugs. Table II and Fig. 2 summarize the results obtained.

Several observations may be made from these data:

(1) The copper crusher gage with a  $1/15$  sq in piston gives substantially the same results as the gage with a  $1/6$  sq in piston in the range of pressures involved.

(2) The internal pressure gages (M-3)

indicate pressures about 20% higher than external gages mounted on the chamber.

(3) Piezo gage readings on the chamber are about 10% higher than copper crusher but 7% lower than internal (M-3) type copper gage readings.

It is of interest to note that a pressure differential of about 2,000 lb/sq in apparently exists between the inside and outside of the shell case. Since the pressures measured are peak pressures only, and since the internal pressure rise must be ahead of the external pressure rise, it is likely that the actual instantaneous difference in pressure between the inside and outside of the shell case is somewhat in excess of 2,000 lb/sq in. A pressure of 2,000 lb/sq in inside a cylinder with the dimensions of a shell case would cause a stress of about 50,000 lb/sq in in the case which approaches the yield strength of the material in a non-heat treated M32 shell case.

## Future Program

Pressure stations will be installed in a T137E3 rifle and the pressure distribution for this rifle determined.

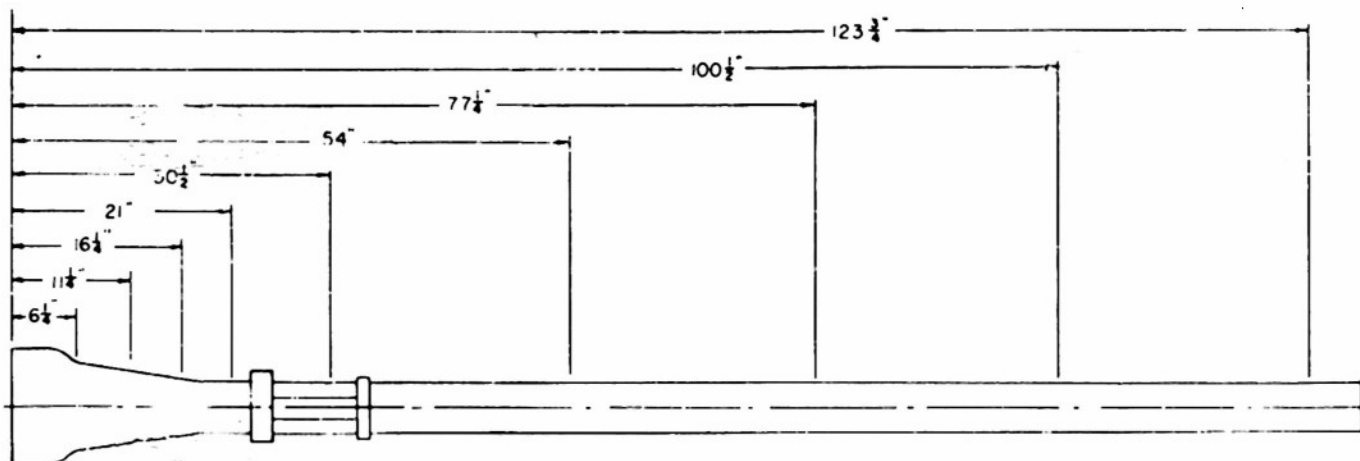

Fig. 1. Pressure Stations, T137E1 Rifle.

# CONFIDENTIAL

**Table II**  
**Pressure Distribution, T137E1 Rifle**

Station	Pressure - Lbs/Sq. in.		
	Cu. Gage 1/6 sq. in. area	Cu. Gage 1/15 sq. in. area	Piezo Gage
1	8,720	8,900	10,140
1	8,920	9,000	---
2	9,360	9,500	10,220
2	9,080	9,050	---
3	9,240	9,000	---
3	9,260	9,300	---
4	9,000	9,300	9,700
4	9,520	9,300	---
5	8,520	8,750	---
5	8,680	---	---
6	6,960	7,000	---
6	7,000	5,850	---
7	4,720	4,550	5,645
7	5,760	4,700	---
8	3,360	---	4,090
9	2,880	---	3,400

Notes:  
 1. Charge 8 lb 1 oz PA30240, .0335-in web.  
 2. Average M-3 internal copper 10,890 lb/sq in.

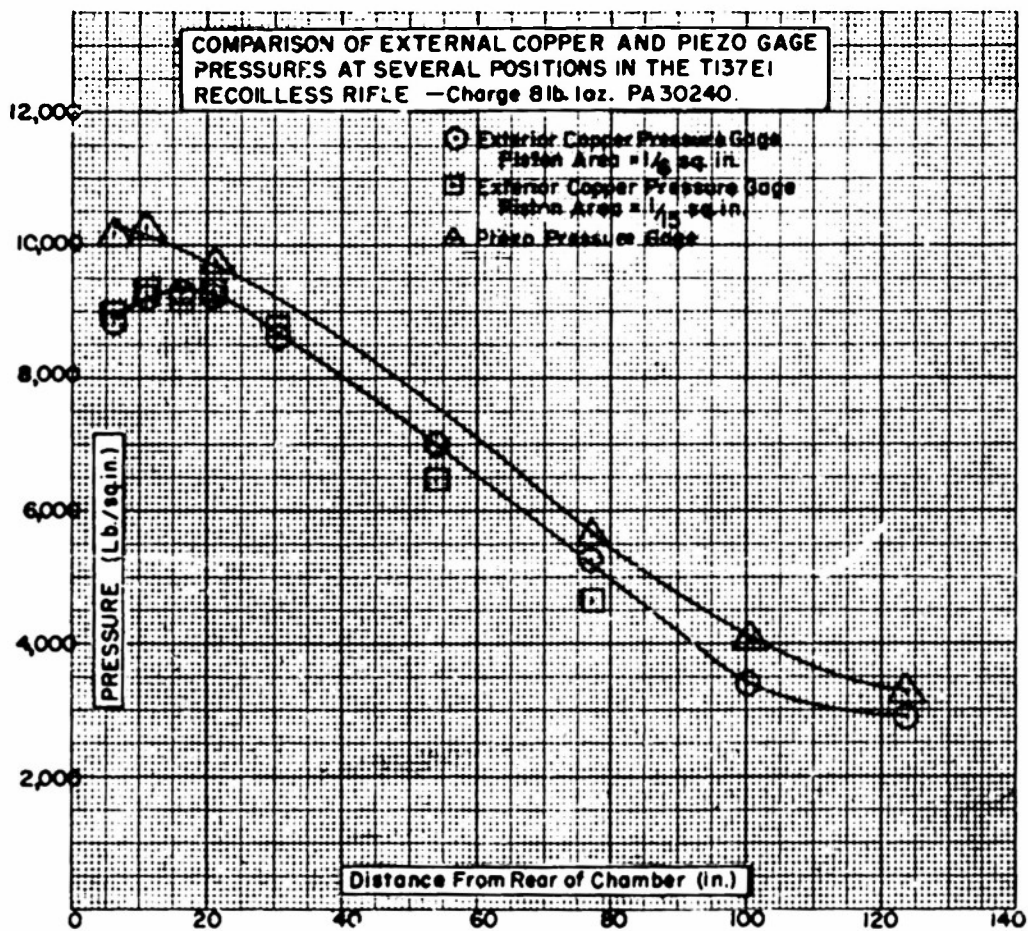

Fig. 2. Comparison of External Copper and Piezo Gage Pressures.  
At Several Positions in the T137E1 Recoilless Rifle.

**C O N F I D E N T I A L**

**T138 PROJECTILE**

Projectiles for determining the effect of center of gravity location and spin rate on the accuracy of the T138 projectile (Twenty-Ninth Progress Report) have been manufactured. The future

program is being amplified to include long range accuracy tests. The availability of adequate range facilities for these tests is being determined.

# CONFIDENTIAL

## T119 PROJECTILE

### Strength Tests of Piston, DRB198

The strength tests of T119E11 projectiles, described in the Twenty-Ninth Progress Report, indicated that the piston had marginal strength. Fig. 3 shows a typical failure. These tests have been continued, using a 105mm recoilless rifle, T137E3, rather than the howitzer, M2A1, used in earlier tests.

To increase the severity of the test, T119E11 projectiles were fitted with special pistons, each having an orifice diameter of .234 in. instead of the usual .196 in. The large orifice allows the propellant gases to reach a higher pressure in the projectile chamber and thereby increases the severity of the fin-stopping stresses on the piston. Nine projectiles were fired under these conditions and eight piston failures were obtained. The range

data are shown in Table III.

A metallographic examination of the piston material (C1141 steel) revealed a coarse grain structure. A number of pistons were therefore heat treated to provide improved ductility and impact strength. The heat treated pistons were tested in T119E11 projectiles by firing at 115 percent of the service charge. For comparison, ten projectiles without heat treated pistons were fired at service charge. None of the pistons having the nominal .196-inch orifice failed, but three of the untreated pistons in the control group did. The range data are shown in Table IV.

Until a new piston, with substantially increased strength can be designed and tested all pistons for T119E11 projectiles will be heat treated.



Complete Piston



Section Through Piston,  
Showing Failure at Neck

Fig. 3. DRB198 Piston From T119E11 Projectiles.

# CONFIDENTIAL

## T119 Cartridge Development

### Projectile Development

Length - A sample quantity of short T119 cartridges (Twenty-Ninth Progress Report) are being manufactured. The study of projectile length is being extended to also include longer projectiles with 2.5 caliber ogive.

Fins - A firing test of T119 projectiles with shorter fins has been scheduled at Erie Ordnance Depot. Projectiles with fewer than six fins will also be tested. A projectile with three fins retains some degree of stability.

Fuzing - Tests of a new plug-in type nose element are described in detail on page 17 of this report. T119E11 projectiles, with similar nose elements, are being assembled for penetration tests against homogeneous armor plate.

Howitzer Firing Tests - While the preliminary tests of the T119E11 projectile in the howitzer, M2A1, (Twenty-Ninth Progress Report) were not completely satisfactory, they were sufficiently promising to justify further tests. Consequently, these tests will be continued with projectiles and charges modified to correct the deficiencies which appeared in the earlier tests.

### Projectile Shipments

<u>Type</u>	<u>Quantity</u>	<u>Shipped To</u>	<u>Date Shipped</u>
T119E11 Inert	200	Picatinny Arsenal	1-15-53
T119E11 Inert	150	Picatinny Arsenal	1-28-53
T119E11 Live	100	Picatinny Arsenal	1-28-53



**Table IV**  
**Range Data**  
**Piston Tests**

**MISCELLANEOUS DATA**  
Range Accuracy Box  
Propellant  
PA-E-619 Type 218AL web used in  
PA-30240 Type 218AL web used in  
Proof Director E. H. HUCKLE  
Observers S. J. KATZ

Date March 14, 1953 Program II19-C-2  
**PISTON TESTS**  
Tubes - 228-865-X  
Chamber - 228-928-0  
Vent Ring - 228-928-N  
Pendulum Mount  
TEST GUN  
Model IZ115  
Type 108mm Recoilless  
Length of Tube 108 in.  
Twist of Rifling 1-80  
Sighting Equipment 211 Adapted Telescope  
Bore Dia. (Lands) .4134 in.  
Pendulum Constant 2.25 ft/sec/in

**TEMPERATURES**  
Max 100°  
Min 40°  
70°  
70°  
70°  
Ambient 18°  
23°

**PROJECTILE**  
Model II19  
Type 611  
Weight (Nominal) 17.52 lb  
C.G. Location  
Bore Dia (Nom.) .4130 in.  
Special Features Blunt Nose

**SCREEN DISTANCES**  
812' 530' 482' 185' 122'

Round No.	Proj. No.	Proj. Weight (lb.)	Powder Charge (lb. - 53)	Powder Lot No.	Chamber Pressure (lb./sq. in.)	Muzzle Velocity (Actual) <sup>a</sup>	Office Dia. (in.)	Recoil (in.)	Fin Speed (in.) <sup>b</sup>						Date Fired	Observations
									1st Year Card	2nd Year Card	1	2	3	12		
4378-1	X 290	17.57	B-4	PA-30240	12,000	1725	.254	-	0	8%	10%	12	12	12	1-5-53	115% charge. New data's show piston failed. Recovered.
4379-2	X 291	17.54	B-6	PA-E-619	10,000	1640	.294	12 1/2 E	10%	10%	10%	11%	11%	-	1-5-53	Inadequate - not recovered
4380-3	X 295	17.58	B-4	PA-30240	12,000	1776	.196	11 1/2 E	10%	10%	10%	10%	10%	-	1-5-53	115% charge. Recovered - satisfactory
4381-4	X 292	17.54	B-4	PA-30240	12,000	1781	.196	6 1/2 E	10%	10%	10%	11	10%	-	1-5-53	"
4382-5	X 296	17.56	B-4	PA-30240	12,000	1737	.196	5 E	10%	10%	10%	10%	10%	-	1-5-53	"
4383-6	X 294	17.54	B-4	PA-30240	12,000	1756	.196	7 1/2 E	10%	10%	10%	10%	10%	-	1-5-53	"
4384-7	X 293	17.52	B-4	PA-30240	11,000	1764	.196	4 1/2 E	10%	10%	10%	10%	10%	-	1-5-53	"
4385-8	X 284	17.52	B-6	PA-E-619	10,000	1698	.196	7 3/4 E	10%	10%	10	10%	10%	-	1-5-53	Standard projectile charge. Recovered - piston failed
4386-9	X 285	17.52	B-6	PA-E-619	10,000	1665	.196	7 1/2 E	10%	10%	10%	10%	10%	-	1-5-53	"
4387-10	X 286	17.53	B-6	PA-E-619	9,000	1653	.196	10 3/4 E	10%	10%	10%	10%	10%	-	1-5-53	"
4388-11	X 287	17.53	B-6	PA-E-619	9,000	1659	.196	10 3/4 E	10%	10%	10%	10%	10%	-	1-5-53	"
4389-12	X 256	17.54	B-6	PA-E-619	9,000	1646	.196	12 E	10%	10%	10%	-	-	-	1-5-53	"
4390-13	X 289	17.52	B-6	PA-E-619	9,000	1643	.196	10 E	10%	10%	10%	10%	10%	-	1-5-53	"
4391-14	X 288	17.53	B-6	PA-E-619	9,000	-	.196	10 3/4 E	10%	10%	10%	10%	10%	-	1-5-53	"
4392-15	X 282	17.52	B-6	PA-E-619	9,000	1648	.196	10 1/2 E	10%	10%	10%	-	-	-	1-5-53	"
4393-16	X 283	17.51	B-6	PA-E-619	10,000	1655	.196	11 1/2 E	10%	10%	10%	10%	10%	-	1-5-53	"
4394-17	X 281	17.51	B-6	PA-E-619	9,000	1639	.196	7 1/2 E	10%	10%	10%	10%	10%	-	1-5-53	"

<sup>a</sup> Retardation factor = 40 ft./g<sub>0</sub>/ft.  
<sup>b</sup> Allowable fin spread variation: 10.50 to 10.82 inches

\* Denotes heat treated piston.

Signer - O. H. 167

# CONFIDENTIAL

## PENETRATION STUDIES

### Effect of Wire Through Ogive

Tests on the effect of a wire located on the axis of a liner, on the penetration obtainable with the liner, have in some cases given contradictory results. The experiments described in this report were set up to reduce to a minimum any uncertainties as to the location of the wire. Two schemes were used; both methods used DRC376 bodies and plugs, with DRC342 ogives (T119) and DRA699 nose caps.

In the group of rounds FS938 to FS 952 inclusive the wire, if used, was tightened just previous to firing, by unscrewing the nose cap. Figure 4 shows the assembly scheme. The wire was fastened to the apex of the cone at one end and was passed through a hole in the nose cap located on the center line of displaced 1/4 in. from the center.

For the group of rounds FS983 to FS 1022 inclusive, two slots approximately 1/2 in. wide and 2 in. long were machined in the side of the ogive, with the long axis of the slot parallel to the slant height of the cone. The two slots in each ogive were placed 90° to each other around the circumference. These slots made it possible to examine the round just before firing to determine both the location of the wire and its tautness. Ten rounds were without wires, ten rounds had the wire drawn taut and secured at the time of assembly, ten rounds were assembled with one half inch of slack in the wires, and the remaining ten rounds were assembled with one inch of slack in the wires. Examination, immediately before firing, indicated that in some cases the supposedly taut wires were not taut. However, the degree of deviation was slight. Figure 5 is a sketch of the experimental arrangement.

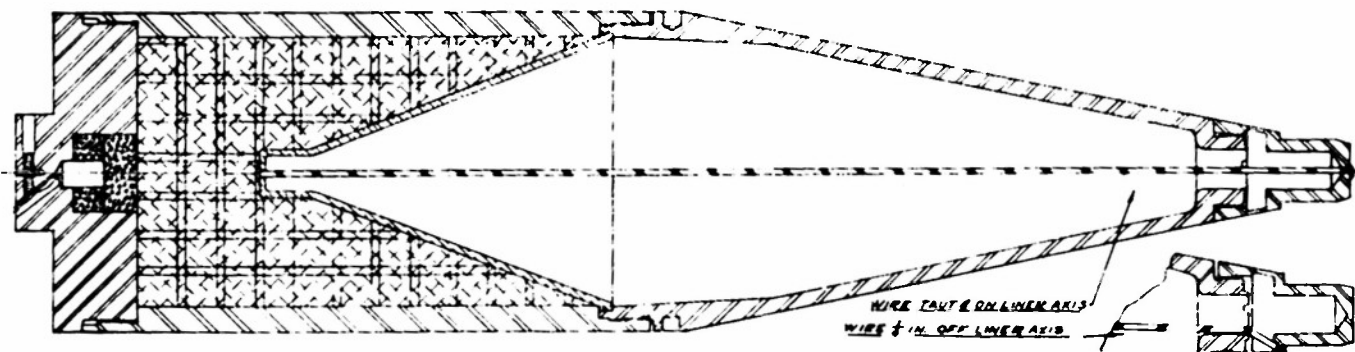

Fig. 4. Test Assembly.

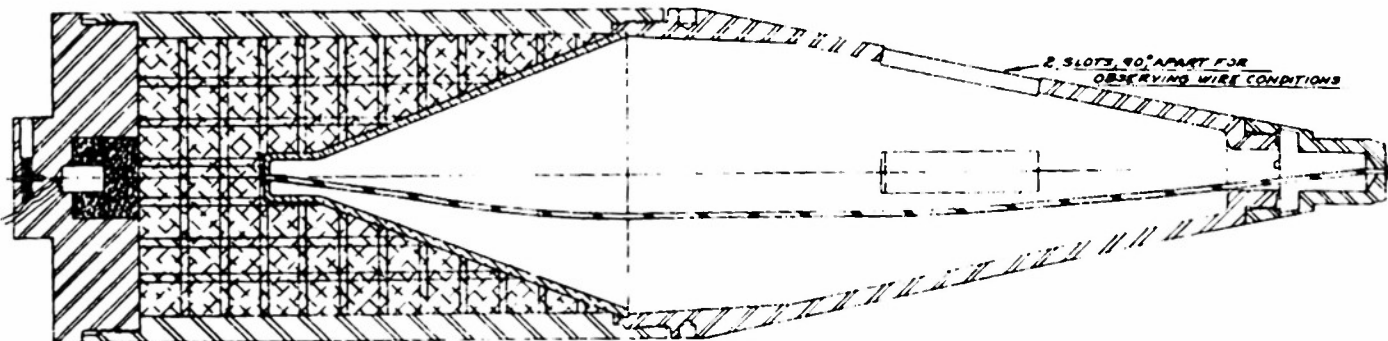

Fig. 5. Experimental Arrangement.

**CONFIDENTIAL**

Table V is a record of the penetration results of the two groups. Some rounds were rotated at 15 rev/sec, to cause the wire to be held off the center line by centrifugal force, if any slackness was present. The results of the two groups of rounds show definitely that:

1. If a beryllium copper wire .040 in. in diameter with an .070-inch nylon insulation lies on the axis of the liner the penetration is greatly reduced.

2. If such a wire is slightly slack so that it may or may not be on the axis the results show interference in a portion

of the cases.

3. If the wires are quite slack the degrading effect on penetration is greatly reduced. This is especially true for rounds which are rotated.

Although these data indicate that the presence of a wire in the cavity is not detrimental unless it is located in the direct path of the jet, it is advisable to continue the practice of insuring that the wire can not line up along the axis of the cone and interfere with the jet functioning.

**Table V**  
**Penetration Data**  
*Effect of Axial Wire On Penetration*

Round No.	Lbs Comp B	Penetration (inches M.S.)	Max. Spread (in.)	Std. Deviation (in.)	Spin (rev/sec)	Remarks
FS938	2.60	21.62			0	No Wire
FS939	2.60	20.31			"	" "
FS940	2.60	20.56			"	" "
FS941	2.58	20.25			"	" "
FS942	2.60	20.81			"	" "
FS983	2.56	21.56			"	" "
FS984	2.62	19.44			"	" "
FS985	2.58	17.44			"	" "
FS986	2.58	21.56			"	" "
FS987	2.60	19.81			"	" "
		Avg. 20.34	4.18	± .35		
FS988	2.60	17.25			15	No Wire
FS989	2.56	18.31			"	" "
FS990	2.58	17.37			"	" "
FS991	2.58	18.50			"	" "
FS992	2.58	18.19			"	" "
		Avg. 17.92	1.25	± .26		
FS943	2.58	4.06			0	Taut wire on center line
FS945	2.60	1.50			"	" "
FS947	2.58	2.06			"	" "
FS995	2.60	7.00			"	" "
FS997	2.60	9.12			"	" "
		Avg. 4.75	7.06	± 1.5		
FS998	2.60	4.75			15	Taut wire on center line
FS999	2.58	4.18			"	" "
FS1000	2.60	7.56			"	" "
FS1001	2.58	3.25			"	" "
FS1002	2.62	8.62			"	" "
		Avg. 5.67	4.37	± 1.0		
FS948	2.60	6.25			0	Wire off g .25 in at front end
FS949	2.58	7.81			"	" "
FS950	2.56	6.50			"	" "
FS951	2.60	9.31			"	" "
FS952	2.58	6.81			"	" "
		Avg. 7.34	3.06	± .56		(cont'd)

C O N F I D E N T I A L

Table V (Cont.)

Round No.	Lbs Comp B	Penetration (inches M.S.)	Max. Spread (in.)	Std. Deviation (in.)	Spin (Rev/Sec)	Remarks
FS993	2.60	19.81			0	Wire slightly slack
FS994	2.58	18.25			"	" " " "
FS996	2.60	16.50			"	" " " "
		Avg. 18.18	3.31	±.96		
FS1003	2.58	18.93			0	Wire with 1/2" slack
FS1004	2.60	19.62			"	" " " "
FS1005	2.60	15.81			"	" " " "
FS1006	2.60	17.87			"	" " " "
FS1007	2.58	19.87			"	" " " "
		Avg. 18.42	4.06	±.74		
FS1008	2.58	18.56			15	Wire with 1/2" slack
FS1009	2.60	17.81			"	" " " "
FS1010	2.62	17.37			"	" " " "
FS1011	2.60	16.87			"	" " " "
FS1012	2.62	18.25			"	" " " "
		Avg. 17.77	1.69	±.30		
FS1013	2.58	21.25			0	Wire with 1" slack
FS1014	2.58	18.87			"	" " " "
FS1015	2.60	19.31			"	" " " "
FS1016	2.60	17.00			"	" " " "
FS1017	2.60	20.12			"	" " " "
		Avg. 19.31	4.25	±.70		
FS1018	2.60	18.75			15	Wire with 1" slack
FS1019	2.58	18.62			"	" " " "
FS1020	2.60	18.25			"	" " " "
FS1021	2.58	19.37			"	" " " "
FS1022	2.58	17.50			"	" " " "
		Avg. 18.50	1.87	±.31		
FS944	2.58	19.62			0	Wire loose from
FS946	2.60	20.31			"	front of ogive
		Avg. 19.97	0.69	.344		
Notes:						
1. DRC376 bodies and plugs; DRC342 ogives (T119); DRA699 nose caps.						
2. All rounds loaded at Ravenna Arsenal, BAT Lot No. 24, with Comp B from Holston Lot No. 3-126.						
3. All rounds fired at a standoff of ogive and cap plus 1/8" (9.4").						

**Effect of Tee Configuration—Machined Liners**

Further studies of the effect of internal tee configuration upon penetration have been completed. In these studies machined cones were used and the results are compared with those of previously reported experiments with drawn cones. Fig. 6 shows the simple nose ring and three types of tees used. The inspection data for the cones were reported in Table VII of the Twenty-Ninth Progress Report. The penetration data are presented in

Table VI. The following tabulation shows the penetration of drawn and machined DRB398 cones in similar tees.

	<u>Drawn(in)</u>	<u>Mach.(in)</u>
Nose Ring	20.8	19.9
DRC314	16.0	15.8
DRC314HW10	16.2	19.2
DRC314HW11	19.7	20.0

**CONFIDENTIAL**

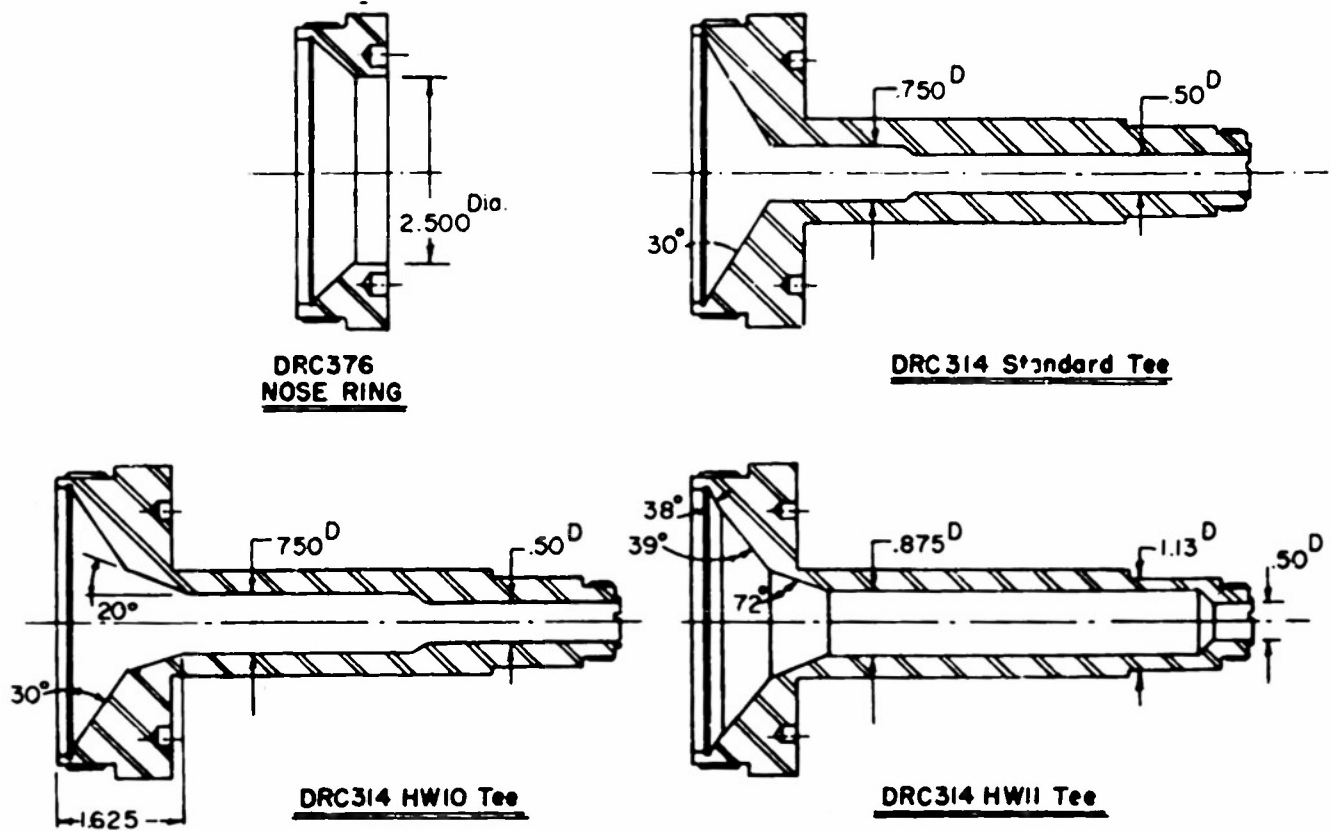

Fig. 6. Nose Ring and Three Tee Configurations.

**Table VI**  
**Penetration Data**  
**Machined Liners - Tee Configuration**

Round No.	Lbs. Comp B	Tee	Penetration (Inches M.S.)	Max. Spread (in.)	Std. Dev. (in.)
FS647	2.58	DRC314	16.94		
FS648	2.54	"	15.25		
FS649	2.58	"	16.25		
FS650	2.60	"	13.88		
FS651	2.58	"	16.69		
			Avg. 15.80	3.06	±1.18
FS652	2.58	DRC314HW10	19.12		
FS653	2.58	"	20.00		
FS654	2.56	"	18.50		
FS655	2.56	"	18.81		
FS656	2.62	"	19.39		
			Avg. 19.16	1.50	±0.58
FS657	2.56	DRC314HW11	20.44		
FS658	2.58	"	19.31		
FS659	2.60	"	20.17		
FS660	2.58	"	19.56		
FS661	2.58	"	20.44		
			Avg. 19.97	1.13	±0.52
FS632	2.58	Nose Ring (DRC376)	19.94		
FS633	2.58	"	20.56		
FS634	2.60	"	19.56		
FS635	2.58	"	19.12		
FS636	2.58	"	20.50		
			Avg. 19.93	1.44	±.62

Notes:  
 1. DRC376 bodies and plugs; booster in base plug.  
 2. Loaded at Ravenna Arsenal, BAT Lot No. 23, with Composition B from Holston Lot 3-126.  
 3. Tested at Erie Ordnance Depot, 0 rev/sec, 7.5 inches standoff.

## CONFIDENTIAL

With the notable exception of the DRC314 HW10 tee there is no significant difference between the behavior of the drawn and machined cones. The intermediate degree of clearance provided by the DRC 314HW10 tee is apparently sufficient for the machined liner but is not sufficient for the drawn liner. Reference should be made to the Twenty-Fourth Progress Report where the effect of tee configuration upon the performance of DRB2 and DRB398 cones was compared. The DRC314 tee did not interfere with the normal penetration of the DRB2 cone. It is now apparent that the reason is not merely because the DRB2 cone is machined from

copper bar while the DRB398 cone is drawn.

A visual examination of tee fragments and slugs has disclosed that the diameter of the slug from the DRB398 cone is larger than the .75-inch bore of the DRC314 tee, but is less than the .875-inch bore of the DRC314 HW11 tee. This observation suggests the possibility that the determining factor might be slug diameter. Slugs from DRB2 cones have been recovered and usually measure approximately .70 in. at their largest diameter. These studies are being continued.

### Future Program

1. Continue tests to determine the effect of interior tee configuration upon penetration.

2. Continue scaling studies with smaller liners.

3. Composite cones. The penetration behavior of steel and aluminum cones having thin copper inserts, and of copper cones with thin aluminum inserts, will be compared with homogeneous copper cones. Initial tests will be at 0 and 25

rev/sec.

4. Cones made of zinc and aluminum are to be tested for penetration. Penetrations approaching those of copper cones have recently been reported for cones of certain zinc and aluminum alloys.

5. Loading tests. The effect of melt holding time upon performance of two different lots of Composition B is to be determined.

# CONFIDENTIAL

## FUZES

### Jolt and Jumble Tests, Base Element, T222E5

Twelve T222E5 base elements (Fig. 10, Twenty-Fifth Progress Report) were sent to Picatinny Arsenal for standard Jolt and Jumble tests. Six were tested without tetryl leads or pellets and the remaining six were equipped with a full explosive train.

The six base elements without tetryl leads and pellets were tested in groups of two. They were subjected to the action of the jolt machine for three hours and then to the jumble machine for three hours. The base elements were then disassembled and examined. No case of arming or damage was found.

The six base elements, containing the tetryl lead and tetryl pellets, were also tested in groups of two with the usual

three hours in the jolt machine and three hours in the jumble machine. Examination of the elements after testing showed no damage or arming.

On the basis of these tests it is planned to test the base elements in HEAT rounds.

### Switch For T267 Superquick and Delay Fuze

A modified type of base element, to include .05 sec delay action, as well as superquick action has been designated T267. (Fig. 27, page 31, Twenty-Second Progress Report). This base element is almost ready for field tests. A switch, to fit the T119 projectile, has been designed and is shown in Fig. 7. This switch makes the selection of the type of functioning, superquick or delay, possible by the use of a screwdriver or similar device.

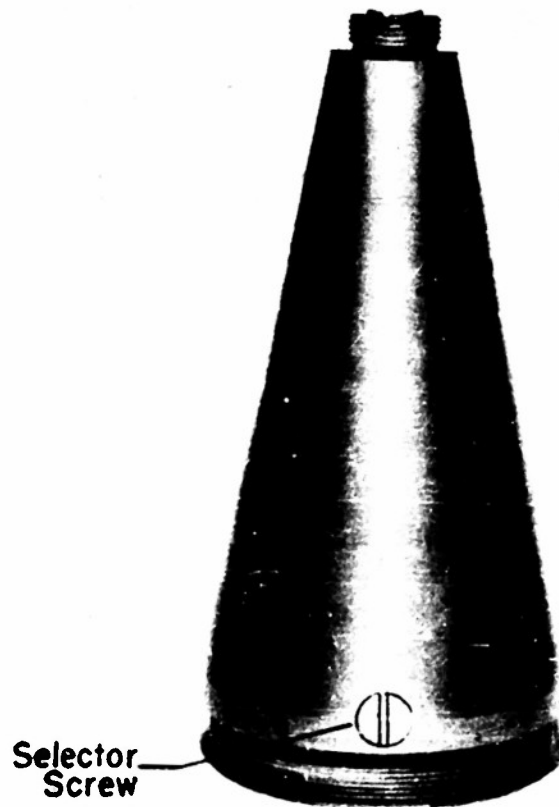
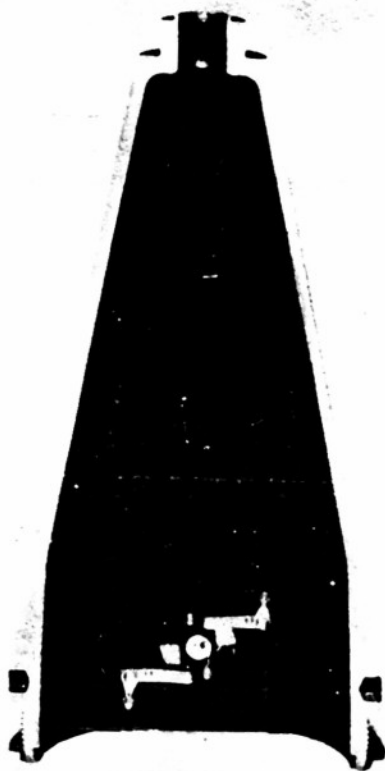

Fig. 7. Selector Switch for T267 Fuze.  
Superquick or Delay.

**Comparison of Voltage Output of DRA726 and DRA496-2 Nose Elements**

Laboratory comparisons of the electrical voltage output of the two crystal assemblies have been made. In this test a 2 1/2-lb weight traveling 4 ft/sec was allowed to strike the exposed crystal assembly mounted on a rigid base. The crystal was connected across a 2000-ohm load and an oscilloscope record of the time-voltage phenomena was taken. Fig. 8 shows the two crystal assemblies, Fig.

9 is a drawing of the experimental procedure and Fig. 10 shows copies of the oscilloscope records. The attenuation used for the DRA496-2 nose element was 30 as compared to an attenuation of 1 for the DRA726 nose element. Allowing for the attenuation, the voltage output for the DRA726 nose element was 8 volts and for the DRA496-2 nose element 350 volts. Thus the DRA726 nose element is considerably less powerful than the earlier form.

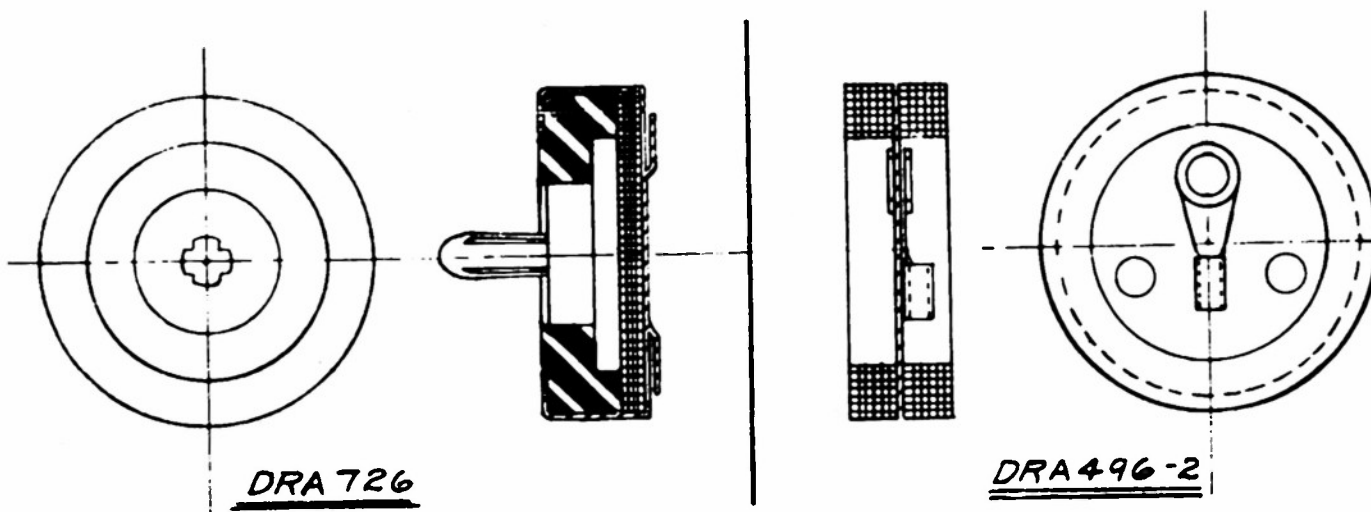

Fig. 8. Crystal Assemblies - DRA726 and DRA496-2.

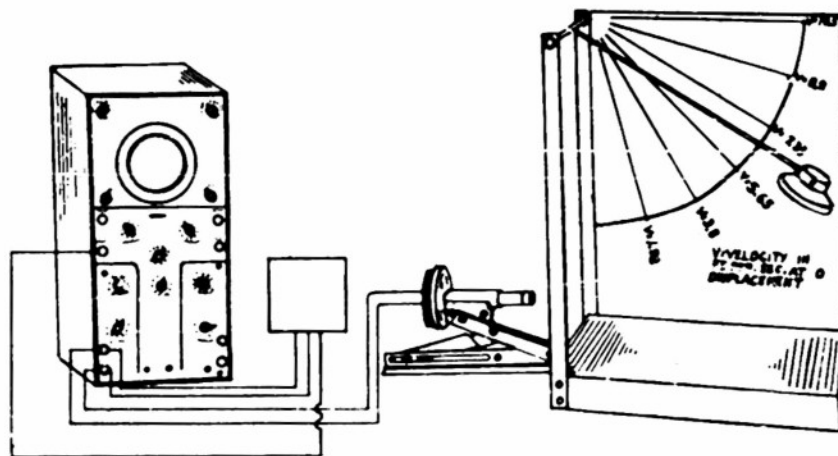
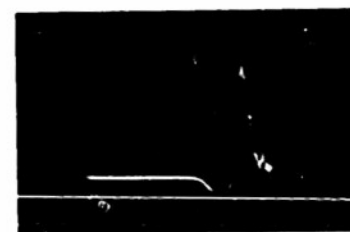

Fig. 9. Experimental Arrangement. Nose Element Tests.



DRA726



DRA496-2

Fig. 10. Oscilloscope Records. Nose Element Time-Voltage Tests.

### Field Tests On DRA726 Nose Element

Ten DRA726 (Fig. 8) nose elements were assembled in T138E57 projectiles. The projectiles were inert loaded and equipped with spotting charges and T208 base elements. These rounds were fired against a 4-inch wood bursting screen at a range of 100 yards. All ten rounds functioned satisfactorily. A group of 50 T138E57 HEAT rounds are being prepared to test the nose element in actual live rounds.

This new nose element assembly has the following advantages:

1. The crystal can be inserted after the projectile is loaded.
2. The crystal is sealed against moisture and corrosion.
3. The crystal is confined and hence is held in position even though it may be cracked or shattered. Tests show that a shattered crystal will generate sufficient voltage if confined to its original shape. Table VII is a copy of the firing record.

### Investigation of 9GA20 Selenium Rectifiers

The electrical charge required for detonating a HEAT shell could be generated by the crystal during impact, stored in a condenser and discharged through the detonator when a nose switch is closed by the impact of the projectile on the target. This study shows the results of some tests using International Resistor Company's 9GA20 No. 1 rectifiers for the purpose of insulating the condenser from the generating source after the charging action. Fig. 11 is a schematic diagram of one means for accomplishing this type of action. An advantage of this type of functioning is that an inertia-actuated switch could be placed in parallel with the nose switch to provide graze sensitivity. Figs. 12 and 13 show the data for a single 9GA20 No. 1 rectifier in series with a DRA496-2 nose element and a .001  $\mu$ f condenser. Figs. 14 and 15 show the data for a single 9GA20 No. 1 rectifier in series with a .001  $\mu$ f condenser.

In each case the time required for the voltage to leak to 1/2 of the initial voltage is well over the time of flight to 1000 yards and in the one case is ample for much longer ranges. Therefore, these rectifiers will be tried in field tests.

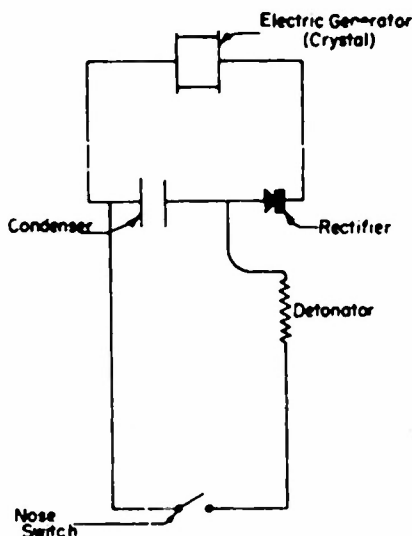

Fig. 11. Schematic Wiring Diagram.

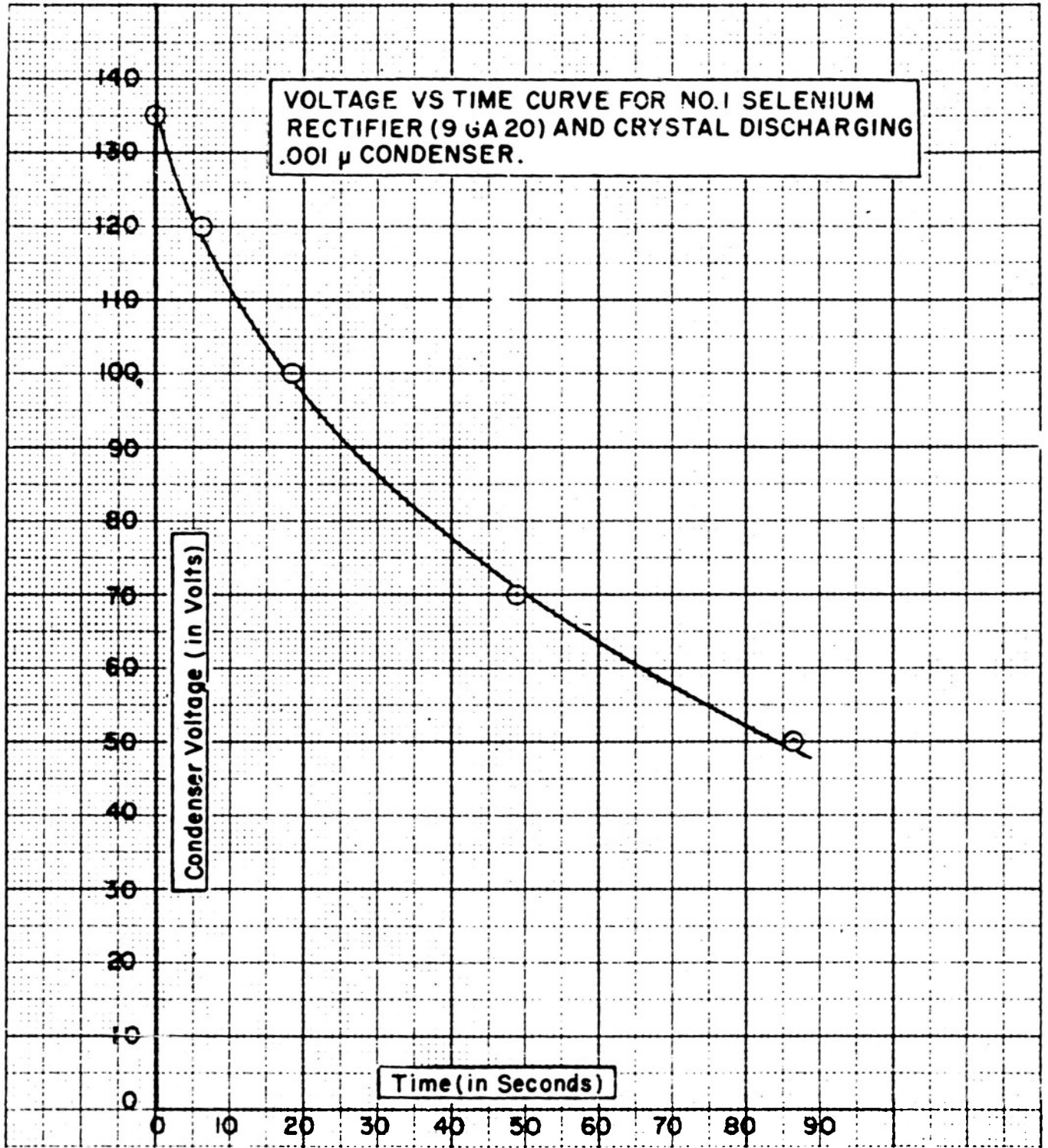

Fig. 12. Voltage Versus Time Curve.  
For: No. 1 Selenium Rectifier (9GA20) and Crystal Discharging Condenser.

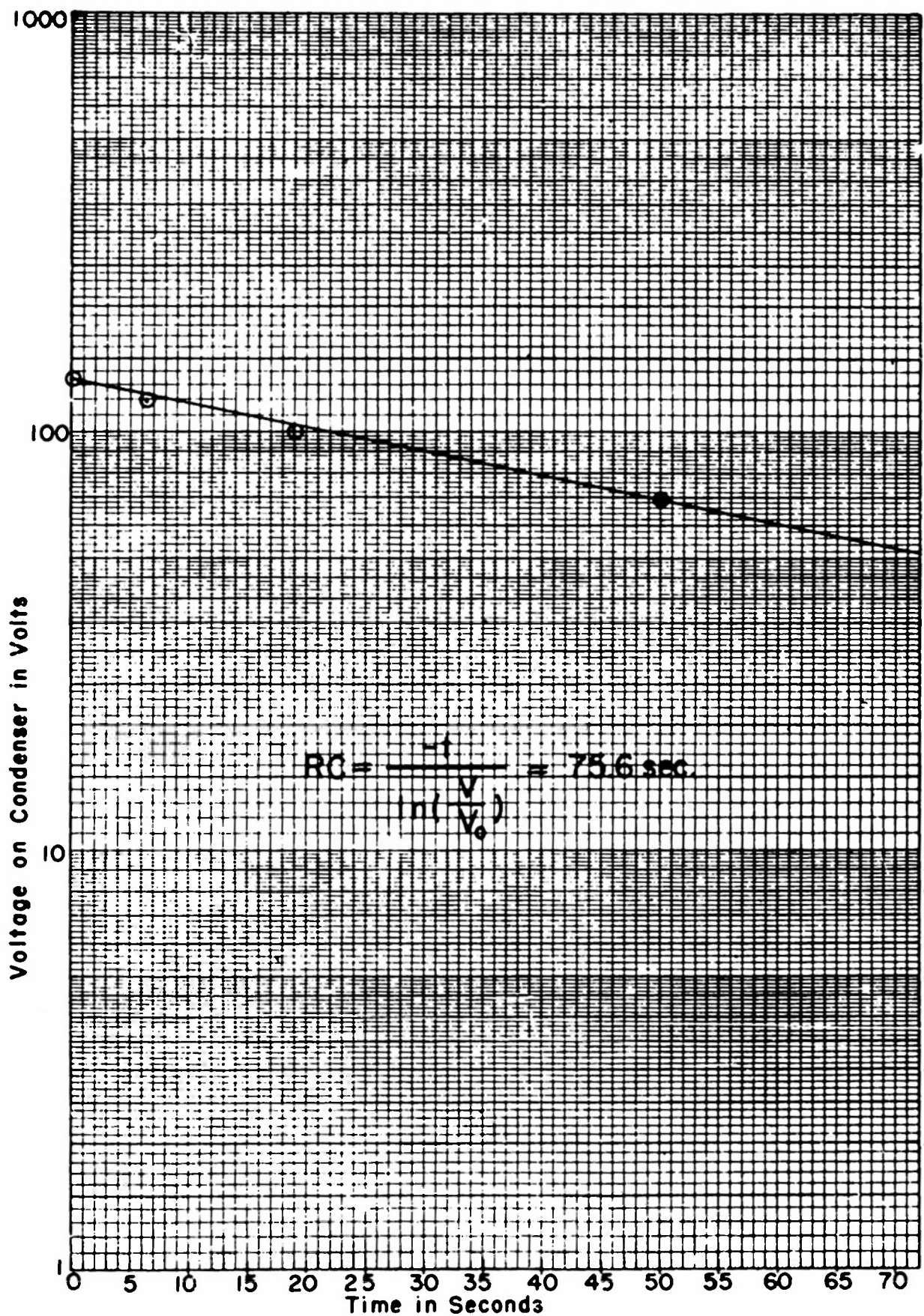

Fig. 13. Voltage Versus Time.  
9GA20 No. 1 Crystal In Series.

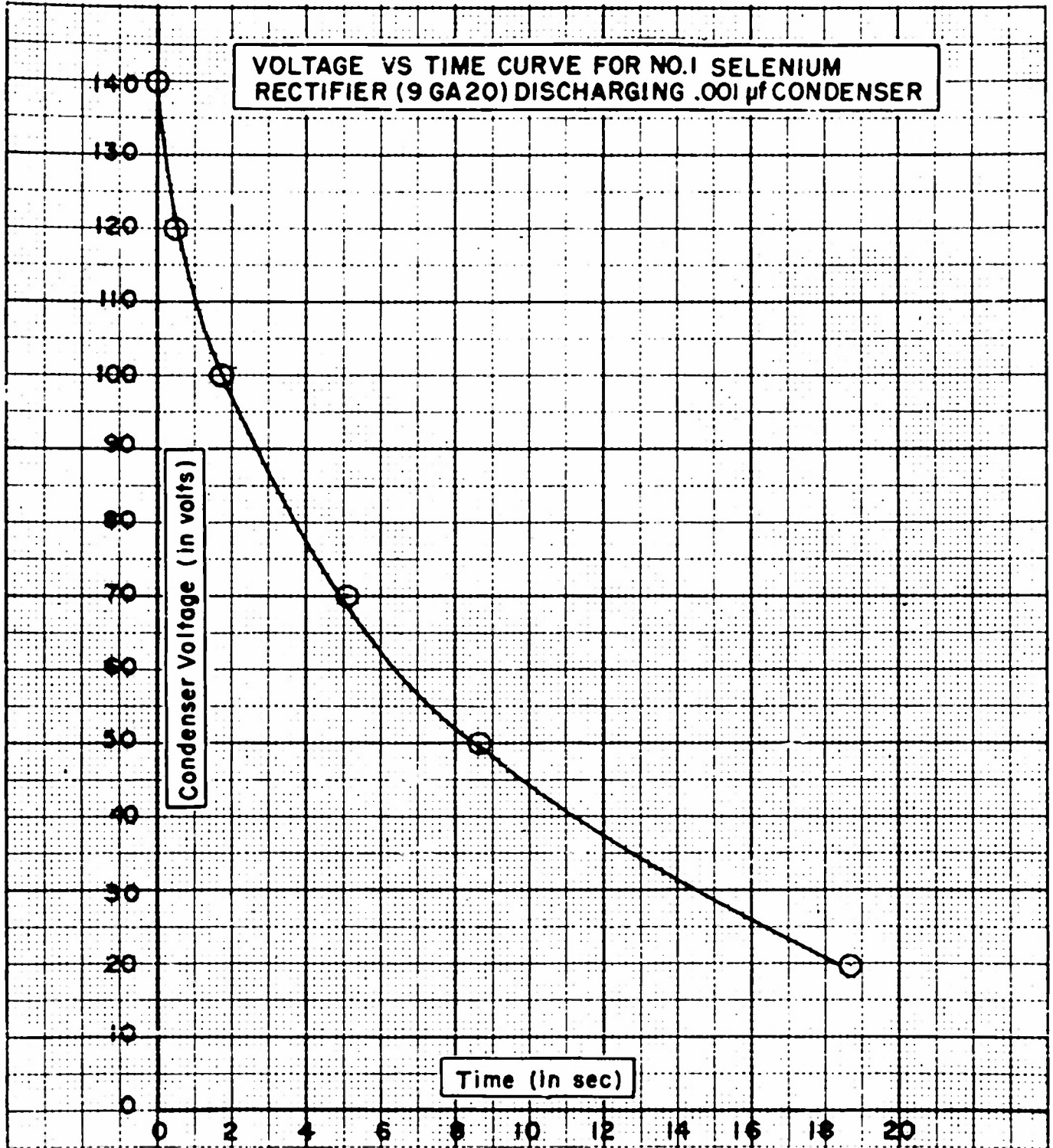

Fig. 14. Voltage Versus Time Curve.  
For No. 1 Selenium Rectifier (9GA20) and Discharging Condenser.

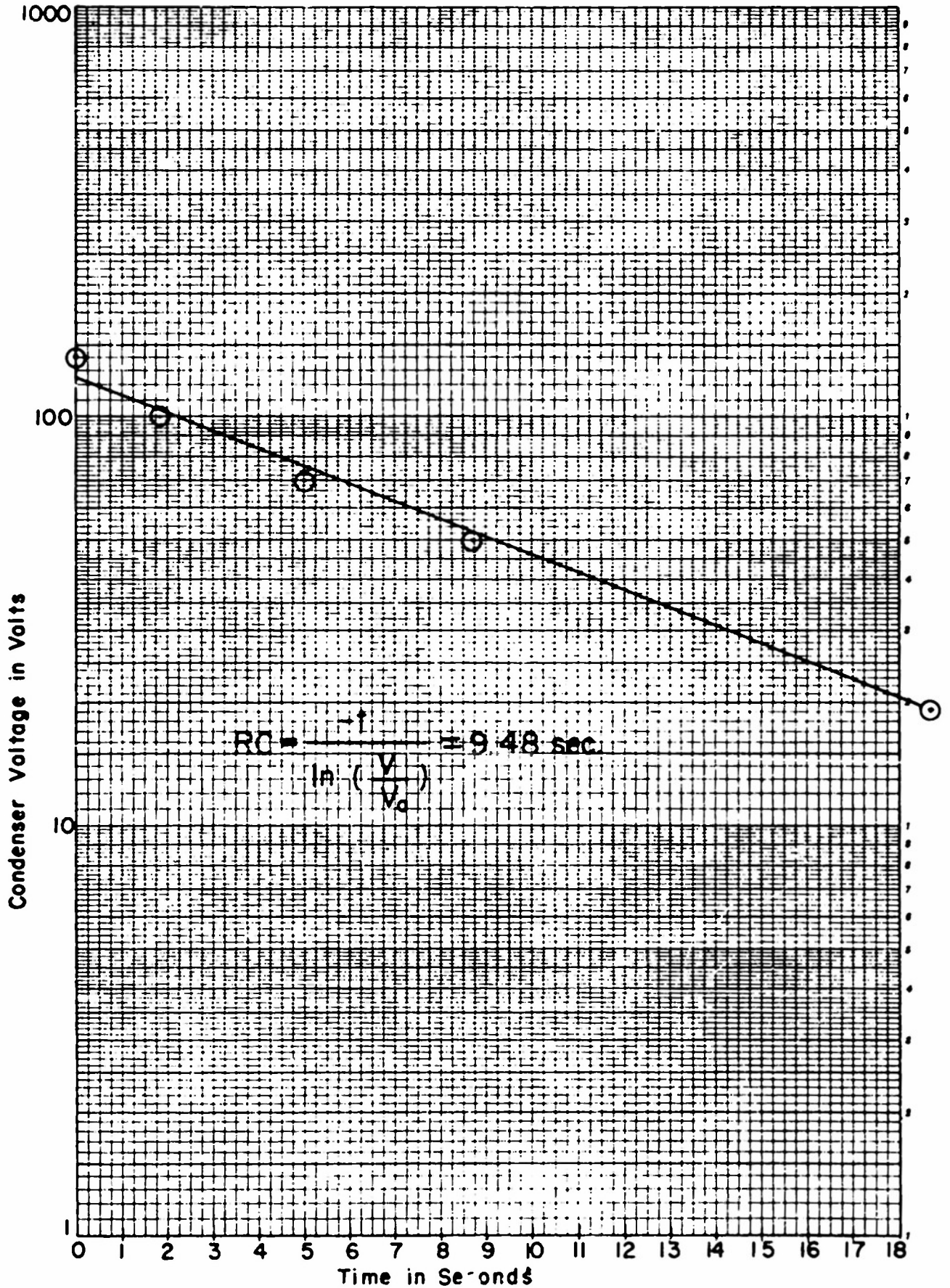

Fig. 15. Voltage Versus Time.  
9GA20 No. 1.

**Table VII**  
**Firing Record**  
**Field Tests On DRA726 Nose Element**

**MISCELLANEOUS DATA**  
Range Indulged Mount To Bursting  
Barrel 50 yds  
Propellant PA 3020 M17 Primer  
Type ALCIC web, ALSCIC Charge VR, B/LA, K&L  
To Ex-inforced cases with TC  
polyethylene liners  
Proof Director EDUCERON  
Observers M. RUSSIA, M. DAVIS, M. TERRY,  
E. McLEAN, L. OLIVER

**TEST GUN**  
Program SUB-11  
Type 12509  
Chamber 7 1/4 No 6  
Vent 7 1/4 72.80826  
Type ALSCIC Recoilless  
Length of Tube 36.14  
Twist of Rifling 1-300  
Sighting Equipment ALZEL/Howa Telescope  
Bore Dia. (Lands) 3.128 700, 1.0

**PROJECTILE**  
Model I13B  
Type E37A  
Weight (Nominal) \_\_\_\_\_  
C.G. Location \_\_\_\_\_  
Borelet Die (Nom.) F.132 .002  
Special Features IZZEEA Fuze System with  
new plug-in nose element (DRA 726)  
and TE00ET base element.  
Retardation factor .200 ft/sec/ft.

TEMPERATURES  
Ambient -30°F  
Muzzle Temp. \_\_\_\_\_  
Bar. 74"  
Pres. 74"  
Room 72"

Round No	Time of Flight	Powder Charge (lb - oz)	Recall (in)	Wind Vel & Dir.	Chamber Pressure (psi)	Muzzle Velocity		Elev. (mils)	Azimuth (mils)	Position of Hit		Corrected Position of Hit - mils		Clearance		Observations	
						Actual	Meas.			Vert.	Horiz.	Vert.	Horiz.	Front	Rear		
4428-1		8-4			12,400	Fired											
4429-2		8-4	5 F		11,700	Functioned at screen											
4430-3		8-4	5 F		11,900	Functioned at screen											
4431-4		8-4	6 1/2		12,000	Functioned at screen											
4432-5		8-4	5 1/2 F		13,100	Functioned at screen											
4433-6		8-4	4 1/2 F														
4434-7		8-4	1 F		12,200	Functioned at screen											
4435-8		8-4	5 1/2 F		12,600	Functioned at screen											
4436-9		8-4	3 F		12,000	Functioned at screen											
4437-10		8-4	8 1/2		12,600	Functioned at screen											
4438-11		8-4	3 1/2		13,000	Functioned at screen											

Selenoid fired mechanically

Borelet Die (Lands) 3.128 700, 1.0

Signed - O. Miller

# CONFIDENTIAL

## Future Program

1. Testing of base elements, T222 E5, in live HEAT projectiles.
2. Testing of base element, T267, for .05 sec delay and superquick action.
3. Evaluation of the nose element DRA 726 for sensitivity by firing against a 1 inch burster screen.
4. Testing of the nose element DRA 726 in live HEAT rounds.
5. Testing of the "inverted" firing system using 9GA20 No. 1 rectifiers and condensers in projectiles with burster charges.

# CONFIDENTIAL

## DISTRIBUTION

Number of Copies	NUMBERS	INSTALLATION Office, Chief of Ordnance
1	1	ORDTS
2	2-3	ORDTA
1	4	ORDTQ
1	5	ORDTR
1	6	ORDTB
1	7	ORDGU-SE
1	8	ORDTU
<b>Arsenals</b>		
10	9-18 incl.	Frankford
2	19-20	Picatinny
1	21	Springfield Armory
<b>Ordnance Districts</b>		
1	22	Cleveland
<b>Aberdeen Proving Ground</b>		
2	23-24	Ballistics Research Laboratory
1	25	Development and Proof Services
<b>Contractors</b>		
2	26-27	Frigidaire Div. Gen. Motors Corp.
1	28	Winchester Repeating Arms Co.
1	29	Remington Arms Co.
1	30	National Forge & Ordnance Co.
2	31-32	Midwest Research Institute
2	33-34	Armour Research Foundation
1	35	Carnegie Institute of Technology
1	36	Arthur D. Little Co.
1	37	The Budd Company
1	38	Franklin Institute
<b>U. S. Navy</b>		
1	39	Bureau of Navy Ordnance
2	40-41	Naval Ordnance Laboratory, White Oak
1	42	Naval Ordnance Test Station, Inyokern
1	43	Naval Proving Ground, Dahlgren