

UNCLASSIFIED

AD NUMBER

AD016776

LIMITATION CHANGES

TO:

Approved for public release; distribution is unlimited.

FROM:

Distribution authorized to DoD only; Administrative/Operational Use; JUN 1953. Other requests shall be referred to Office of Naval Research, ATTN: Code 280, 875 North Randolph Street, Arlington, VA 22203. Pre-dates formal DoD distribution statements. Treat as DoD only.

AUTHORITY

ONR ltr dtd 26 Oct 1977

THIS PAGE IS UNCLASSIFIED

AD No. 6-776

ASTIA FILE COPY



NEW YORK UNIVERSITY

College of Engineering
RESEARCH DIVISION
University Heights, New York 53, N. Y.

Electron Transit Lags in Geiger Counters

PROJECT NO. 141

REPORT NO. 141.05

JAMES HEITZLER

JUNE 1953

SPONSORED BY OFFICE OF NAVAL RESEARCH

Contract No. N6onr279, T. O. 12

SI

ELECTRON TRANSIT LAGS IN GEIGER COUNTERS

Project No. 141

Report No. 141.05

Prepared by: James R. Heirtzler

James R. Heirtzler

Ass't Proj. Director

Approved by: Serge A. Korff

Serge A. Korff

Project Director

Harold K. Work

Harold K. Work

Director of Research Division

OFFICE OF NAVAL RESEARCH

Contract No. N6onr279, T. O. 12

MANUFACTURED IN THE UNITED STATES BY THE OFFICE OF
PUBLICATIONS AND PRINTING OF NEW YORK UNIVERSITY

ABSTRACT

This report describes work done in measuring the transit time of an electron from the cathode to the central wire of a selfquenching Geiger counter. The electron was ejected from the cathode wall by light from a high voltage spark. The light from this spark also fell on a vacuum photo-cell and gave an electrical pulse, the beginning of which indicated zero time. The time interval between the beginning of this pulse and the beginning of the electrical pulse from the Geiger tube is shown to be the transit time of the photoelectron in the Geiger tube. This time interval, called the time lag, was measured by a delayed coincidence circuit. Under given conditions the time lag was found to be distributed about a most probable value, according to a Gaussian, or Poisson distribution law. The half-width of the distribution was found to be about 0.07 microseconds for all of the counters tested.

The counters tested had various filling mixtures. All of the counters contained argon and one of the following organic vapors: ethyl alcohol, ethyl ether, petroleum ether, or amyl acetate. The time lags in these fillings was not previously known accurately. The partial and total pressure of the filling constituents, the cathode diameter, and the overvoltage were varied during the measurements. In all fillings for the smaller size counters, except where ethyl ether was used, the time lag was found to be between 0.45 and 0.95 microseconds. The lags in the ethyl ether fillings were slightly shorter.

In accordance with recent measurements of electron mobilities in Geiger counter filling mixtures, a new formula was calculated for electron transit times. The time lags calculated by this formula are shown to be in general agreement with the time lags measured. The time lag measurements of other persons, using different techniques of measurements, are found to approximate those lags measured by the author, in cases where comparison is possible.

ACKNOWLEDGEMENTS

The author would like to express his appreciation to Dr. S. A. Korff for advice given during the course of this work, and to the Office of Naval Research and the Bureau of Ships for assistance rendered through contract N6onr279, Task Order 12.

TABLE OF CONTENTS

	Page
Abstract	1
Acknowledgements	ii
Table of Contents	iii
List of Figures	iv
List of Tables	vi
I. Introduction	1
II. Equipment	
A. Vacuum System	4
B. Electronic Circuitry	5
III. Presentation of Data	
A. Comments on the Data	13
B. Data in Tabular Form	15
C. Data in Graphic Form	
IV. Discussion of Results	
A. Distribution of Delays	22
B. The Time Interval Measured	25
C. Electron Mobilities	26
D. Comparison with Other Experimental Measurements	31
E. Practical Results	32
Bibliography	34

LIST OF FIGURES

- Fig. 1 Vacuum System.
- Fig. 2 Block Diagram.
- Fig. 3 Physical Arrangement.
- Fig. 4 Spark Circuit.
- Fig. 5 Amplifier.
- Fig. 6 Geiger and Photo Preamplifier.
- Fig. 7 Shapers and Coincidence Circuit.
- Fig. 8 Discriminator Circuit.
- Fig. 9 Pulse Lengthener and Typical Recorder.
- Fig. 10 Automatic Cutoff Circuit.
- Fig. 10A Resolution of Coincidence Circuit.
- Fig. 11 Variation of Most Probable Lag with Overvoltage and Percentage Alcohol, 6 cm Cathode Diameter, 14 cm Total Pressure.
- Fig. 12 Variation of Most Probable Lag with Overvoltage and Total Pressure, 10% Alcohol and 90% Argon, 6 cm Cathode Diameter.
- Fig. 13 Variation of Most Probable Lag with Overvoltage and Percentage Alcohol, 14 cm Total Pressure, 7/8 inch Cathode Diameter.
- Fig. 14 Variation of Most Probable Lag with Overvoltage and Total Pressure, 10% Alcohol and 90% Argon, 7/8 inch Cathode Diameter.
- Fig. 15 Variation of Most Probable Lag with Overvoltage and Total Pressure, 10% Petroleum Ether and 90% Argon, 7/8 inch Cathode Diameter.
- Fig. 16 Variation of Most Probable Lag with Overvoltage and Total Pressure, 10% Ethyl Ether and 90% Argon, 7/8 inch Cathode Diameter.
- Fig. 17 Variation of Most Probable Lag with Overvoltage, Total Pressure, and Percentage Amyl Acetate, 7/8 inch Cathode Diameter.

Fig. 18 Typical Distribution of Coincidences.

Fig. 19 Duration of Light from Spark.

Fig. 20 Exaggerated Representation of Pulses.

Fig. 21 Comparison with Data of Laufer.

LIST OF TABLES

		Page
Table I.	Purity of Liquids	4
Table II.	Chemical Formulae and Molecular Weight of Vapor.	14
Table III.	Most Probable Lag as Function of Overvoltage and Percentage Alcohol, 14 cm Total Press, 6 cm Diameter Cathode.	15
Table IV.	Most Probable Lag as Function of Overvoltage and Total Pressure, 10% Alcohol and 90% Argon, 6 cm Diameter Cathode.	16
Table V.	Most Probable Lag as Function of Overvoltage and Percentage Alcohol, 14 cm Total Pressure, 7/8 inch Diameter Cathode.	17
Table VI.	Most Probable Lag as Function of Overvoltage and Total Pressure, 10% Alcohol and 90% Argon, 7/8 7/8 inch Diameter Cathode.	18
Table VII.	Most Probable Lag as Function of Overvoltage and Total Pressure, 10% Petroleum Ether and 90% Argon, 7/8 inch Diameter Cathode.	19
Table VIII.	Most Probable Lag as Function of Overvoltage and Total Pressure, 10% Ethyl Ether and 90% Argon, 7/8 inch Diameter Cathode.	20
Table IX.	Most Probable Lag as Function of Overvoltage, Percentage Amyl Acetate, and Total Pressure, 7/8 inch Diameter Cathode.	21

PART I

INTRODUCTION

It is the purpose of this report to describe work done in measuring the transit time of an electron from the cylinder to the central wire of a Geiger counter. This was accomplished by ejecting a photoelectron from the inside wall of the counter at a known instant in time and determining when it reached the region of electron multiplication, which is very near the central wire. After the electron has reached the multiplication, or avalanche, region and the first Townsend avalanche has formed the discharge will continue to spread down the wire and the positive ion sheath remaining after the discharge will then move out toward the cathode. All of these processes determine the electrical pulse from the Geiger tube. The circuits used in the present work are such that the Geiger pulse will be detected after a time equal to the transit time of the photoelectron to the avalanche region, plus the much shorter time of avalanche formation.

The electron was ejected from the wall of the counter tube by light from a spark of short duration. Light from this spark fell on a vacuum phototube and gave a "photo pulse", the beginning of which indicated the instant when the photoelectron was ejected in the counter, and so served to indicate time zero. It has been shown¹ that current will flow in the phototube after a time of no more than 10^{-8} seconds after the light falls on it. The time interval between the beginning of the photo pulse and the beginning of the Geiger pulse was the actual time interval measured.

¹ E. O. Lawrence and J. W. Beams, Phys. Rev. 32, 478 (1928).

A delayed coincidence circuit was used to measure this interval. The circuit indicated what percentage of those Geiger pulses caused by the spark (there is always a small amount of random background radiation) lay within its resolving time, and this resolving time was short. The measuring interval of this instrument could be shifted in time with respect to the beginning of the photo pulse. In this way a distribution of lag times could be determined under fixed conditions.

The peak of the lag distribution depends upon the geometry and filling of the counter, as well as on the voltage applied to the counter. For different geometry and filling mixtures the most probable lag was measured as a function of overvoltage, where overvoltage is defined as "the difference in voltage between the operating potential and the threshold for Geiger counting action"².

Other persons have made measurements of the time interval between the ionizing event and the recording of the Geiger pulse, although not exactly by this same method, and not for the same filling mixtures. Den Hartog, et. al.³, have measured the time difference between the discharge in two counters, as did Sherwin⁴. Such lags are usually called relative lags, in contrast to the present method which can be called a measure of the absolute lag. The Montgomerys⁵, who were the first to use this spark technique to measure lags, were interested in measurements of negative ions in counters. Kitchen⁶ was also concerned mainly with the effect of negative ions when he used the spark technique. Laufer⁷ used this method of triggering his

² S. A. Korff, Electron and Nuclear Counters (Van Nostrand Company, Inc., New York, 1945), p. 15.

³ H. den Hartog, F. A. Muller, and N. F. Verster, Physica 13, 251 (1947).

⁴ C. W. Sherwin, Rev. Sci. Inst. 19, 111 (1948).

⁵ C. G. Montgomery and D. D. Montgomery, Rev. Sci. Inst. 18, 411 (1947).

⁶ S. W. Kitchen, N. Y. U. Project Report No. 141.01.

⁷ A. R. Laufer, Rev. Sci. Inst. 21, 244 (1950).

counters, but he, as well as Kitchen, employed a different technique to measure the lags. A more complete history of time lag measurements has been given by Agresta⁸.

The results of the present work are compared to the results of Laufer, where comparison is possible.

⁸ J. Agresta, N.Y.U. Project Report No. 141.04.

PART II
EQUIPMENT

A. Vacuum System.

A sketch of the system used to evacuate and fill the counters is shown in Fig. 1. The high vacuum pump is a two-stage oil diffusion type, with an oil purifying unit, and uses Octoil S oil; this pump was constructed by Mr. H. Leuthner. The remainder of the evacuating apparatus is conventional.

The section for filling the counter contains a gas reservoir, and a flask containing organic liquid, which supplies the organic vapor. For the most part the gas reservoir was a flask of spectroscopically pure argon gas, supplied by Linde Air Products Company, and provided with a breakoff tip. The larger sized counters were filled with tank argon. An absolute mercury manometer read the pressure in this gas reservoir, while a second similar manometer read the filling pressure. The mercury in both manometers was topped with about one centimeter of Octoil S in each arm to prevent evaporation of mercury vapor⁹.

When the system was being evacuated the vapor reservoir was pumped off until the liquid lost an appreciable fraction of its volume and the thermocouple gauge indicated a good vacuum (about 10^{-3} mm of Hg). This insured vapor, but no air, above the liquid in the vapor reservoir. The purity of the liquids giving the vapors is shown in Table I:

TABLE I
PURITY OF LIQUIDS

<u>Liquid</u>	<u>Purity</u>
Ethyl Alcohol	Absolute
Isoamyl Acetate	C.P.
Ethyl Ether	Meets A.S.C. specifications, at least 99.9% pure
Petroleum Ether	Certified, however this is a mixture of several compounds

After the vapor was purified, in the manner described above, the counter was evacuated to 10^{-5} mm pressure, baked for two hours at 250°C by infrared lamps, and the central wire glowed. Then the manifold and counters were shut off from the pumps and gauges and filled to the desired pressure. The gas and vapor were allowed to diffuse twelve hours before the counter was tested. If the Geiger plateau was less than 200 volts long the counter was emptied, and the filling procedure repeated.

B. Electronic Circuitry.

A block diagram of the circuits involved is shown in Fig. 2. Essentially these circuits comprise a delayed coincidence unit, with power supplies, amplifiers, and recorders. The spatial arrangement of the parts is illustrated in Fig. 3.

1. Geiger Tubes.

Two sizes of Geiger tubes were used in this work. The cylinder of the larger was 6 cm in diameter and 22.9 cm long; the cylinder of the smaller was 2.2 cm ($7/8$ inch) in diameter and 15.2 cm long. Both had a three mil central wire, leaving the pyrex glass envelope at both ends. The light from the spark entered the counter through a 1.27 cm diameter vicor¹⁰ window in the glass envelope and through a 0.16 cm diameter hole in the cathode. Cathodes were of copper. It was ascertained that light from the spark did, in fact, give a Geiger pulse by having the sweep of an oscilloscope triggered by the photo pulse and noting that a Geiger pulse consistently appeared near the beginning of the sweep. This also gave an estimate of the most probable time lag to be expected.

⁹ This process was first suggested by F. Ayer, Rev. Sci. Inst. 21, 496 (1950).

¹⁰ Vicor is a product of Corning Glass Works and allows passage of light down to a wavelength of 2100 Angstroms.

2. Spark Circuit.

The spark circuit is the same as was used by Kitchen¹¹ in new housing and shielding. Basically this circuit (shown in Fig. 4) is a high voltage rectifier which charges a capacitor up to the potential at which a spark occurs between the steel spheres and discharges the capacitor. The probe between the spheres helps the discharge to build up quickly. The distance between the spheres and the positioning of the probe was adjusted so that two or three sparks occurred each second. The duration of the light of the spark is discussed in Part IV.

It should be mentioned that recently Hornbeck¹² has perfected a sparking circuit of slighter shorter light duration. However Hornbeck's paper appeared too late to permit his circuit to be used in the present work.

3. Geiger Counter Power Supply.

The high voltage power supply for the Geiger counter was a conventional 0 to 1500 volt supply, regulated, and continuously variable from 720 to 1500 volts. It was necessary to use a power supply with a fairly low ripple output because this supply was directly connected to a very high gain amplifier.

4. Amplifiers.

In order to measure the time interval between the beginnings of the photo and Geiger pulses amplifiers of high gain and short rise time were needed and such were used in this work. An Elmore and Sands Model 50 amplifier¹³ was chosen because, in addition to satisfying the

¹¹ S. W. Kitchen, op. cit.

¹² J. A. Hornbeck, Phys. Rev. 83, 374 (1951).

¹³ W. C. Elmore and M. Sands, Electronics (McGraw-Hill Book Company, Inc., New York, 1949), p. 160.

two above requirements, it also has preamplifiers that can be located directly at the phototube and the Geiger tube. The amplifier is linear in voltage amplification up to an output of 40 volts, at which voltage the output saturates. Saturation is always reached in the equipment, as it is used here, and aids in the shaping of the pulses in the following circuits. The maximum overall gain of the amplifier is 150,000 and the rise time is 0.06 microseconds. Two amplifiers were constructed, one for each channel, so that if any loss of pulse shape occurred it would be the same for both pulses. One amplifier would not suffice because a time delay had to be inserted in one channel and not in the other. The diagram of these amplifiers, with their preamplifiers, is given in Figs 5 and 6. A Weston Electric regulated power supply provided voltage for the two amplifiers, which drew a total of 240 ma.

5. Oscilloscope.

A DuMont type 274 oscilloscope was placed between the preamplifier and the amplifier in the Geiger pulse channel to monitor the Geiger pulses and indicate the extent of the Geiger plateau. The two amplifying tubes in the preamplifier had a total gain of six; the gain of these two tubes in themselves may not be linear, but their output will be indicative of the relative pulse heights.

6. Delay Lines.

The delay line consisted of a continuously variable line in series with one of several fixed lines¹⁴. The continuous line was calibrated in units of 0.01 microseconds; the fixed delays were in units of 0.5 microseconds. The accuracy of the delay lines was checked in an overall test for accidental delays, to be described later.

¹⁴ The continuously variable delay line was the type 302 delay line manufactured by Advance Electronics Company, Passaic, New Jersey. The fixed delay lines were type 34750 manufactured by James Millen Mfg. Co., Malden, Mass.

7. Shapers.

A coincidence circuit gives an output if any part of two input pulses overlap in time. For this reason it was necessary to convert the two amplified pulses into narrow, square pulses whose leading edges coincide with the leading edges of the amplified pulses. To shape the pulses thus a high current, high frequency tube was used (see Fig. 7). A short circuited delay line was placed in the output to reflect a negative pulse back to cancel the positive pulse after 0.1 microsecond. Since a negative pulse of 0.1 microseconds length will remain at the end of the amplified pulse, and this negative pulse is undesirable, a crystal diode was connected across the line to suppress it. A 1000 ohm resistor was also put across the line to damp out reflections. The circuit gave a very square positive output 0.1 microseconds wide and about 200 volts in amplitude, as viewed on the one microsecond sweep of a Tektronics type 511AD oscilloscope. Different values of cathode resistor were used in the shapers to improve each pulse shape.

8. Coincidence Circuit.

The coincidence circuit was also taken from Elmore and Sands¹⁵ (see Fig. 7). The two positive pulses were fed into the grids of a 6SN7 which is normally cut off. The extra half 6SN7 maintains cathode bias on the tubes when only one pulse tends to make the tube conduct, preventing any output. Actually some "feed through" did occur with only one input and for this reason a discriminator circuit was constructed. The coincidence and shaping circuits normally drew 72 ma. from two Kepco power supply units connected in parallel.

¹⁵ W. C. Elmore and M. Sands, op. cit., p. 120.

9. Discriminator.

A simple pulse height discriminator was built using a 6AK5 miniature tube (see Fig. 8). Although other tubes have sharper cutoff characteristics it was decided to use a 6AK5 because this type tube was used elsewhere in the apparatus and thus reduced replacements which were kept on hand. Another Kepco power supply gave the necessary voltages and the variable bias provided a voltage variation of the discrimination level. A 0 to 50 microampere meter can be read directly in volts, when used as shown in Fig. 8, to give an indication of this discrimination level. It normally was set at -11 volts.

10. Pulse Lengthener and Recorders.

The pulse which may leave the discriminator would still be of the order of 0.1 microseconds wide and so must be lengthened and given power if it is to actuate a mechanical counter. The circuits which will lengthen the pulse and give it power are shown in Fig. 9. The lengthener is a triggered univibrator, giving a long positive pulse which causes a normally cutoff half 6SN7 to conduct, thereby actuating a plate circuit relay and giving a count on the mechanical counter. Three of these recorders were constructed, one to read coincidences, one to read total photo pulses, and the other as a spare and used to check the Geiger channel. The Geiger recorder was disconnected when the apparatus was operating normally. In one recorder a 5000 ohm plate relay was used and the use of this component necessitated putting a 2700 ohm resistor in series with the plate lead of that recorder. Also, a 500,000 ohm instead of a one megohm resistor was used in the grid circuit of one of the recorders to correct for tube characteristics and make all of the recorders behave similarly.

11. Automatic Cutoff.

Since the immediate objective of these measurements was to determine the ratio of coincidence counts to sparks for a particular setting of the delay, it was necessary to record the number of coincidences for a given number of sparks. Reasonably good statistical accuracy could be obtained by counting the number of coincidences during 500 sparks. To turn off the spark generator after 500 sparks an electrical-mechanical arrangement was made to turn off the power to the spark circuit after this time. Small metal plates were put on the numbers of the mechanical counter in the spark recorder so that when it read 500 or 000 a circuit would be completed, a relay energized, and power to the spark interrupted. This circuit is shown in Fig. 10. The cutoff circuit must be broken for just one spark and the apparatus will be ready to shut off again after the next 500th spark.

12. Performance of the Apparatus.

Before checking the performance of the apparatus, each unit was carefully shielded electrically. Units of particular sensitivity to shielding were the spark, recorders, and the two preamplifier stages. Since there must be a bare lead on the input to the Geiger preamplifier, the whole box housing the Geiger tube had to be shielded.

To check the resolving time of the coincidence circuit, the same pulse was put into the two main amplifiers by a co-axial T connector. The delay line was put first in one channel and then in the other and the delay was increased until no coincidences were recorded. This point was defined to within 0.01 microseconds. The "no coincidence" delay was 0.12 microseconds with the delay in the photo channel and 0.10 microseconds with the delay in the Geiger channel, giving a resolving time of 0.22 microseconds (cf. Fig. 10A). This resolving time is just about what would be expected

from observation of pulse outputs from the shapers.

As a check on the accuracy of the delay lines and on accidental time loss in circuits, the equipment was turned on as in normal operation and two pulses, a known time interval apart, were put in the input of the preamplifiers. The two pulses were obtained from a Berkeley Double Pulse Generator, Model 903, and the time separation of the pulses was calibrated against a sweep on a Tektronics type 511AD oscilloscope, which sweep was in turn calibrated against a standard five megacycle signal. By noting where coincidences were recorded with these two pulses, it was learned that readings may be in error by ± 0.05 microseconds; however, lag distribution curves, to be described later, indicate a smaller error.

Before any measurements were made the light path to the counter was blocked to see that no coincidences were observed for all delay settings.

13. Comparison with Other Method.

Laufer¹⁶ and Kitchen¹⁷ have measured the absolute time lag with a spark by simply letting the photo pulse trigger a synchroscope and noting the time of arrival of the Geiger pulse. The present method can be considered as an improvement over their method in four respects:

- a) The amplifiers have a greater gain, probably faster rise time, and have a Geiger preamplifier located directly at the Geiger tube.
- b) Better statistical accuracy was obtained because more counts were taken, roughly 10,000 to their 100 for each overvoltage.
- c) Any major asymmetry in the distribution of time lags will be evident because no simple arithmetical average of the lags was made.
- d) Less physical labor was involved in determining the lag, with accom-

¹⁶ A. R. Laufer, op. cit.

¹⁷ S. W. Kitchen, op. cit.

panying personal error.

The disadvantages of this method in comparison with theirs is that more electronics is involved, which must be kept in perfect order, and it takes longer to find the most probable lag at a given overvoltage.

VACUUM SYSTEM

FIG. I

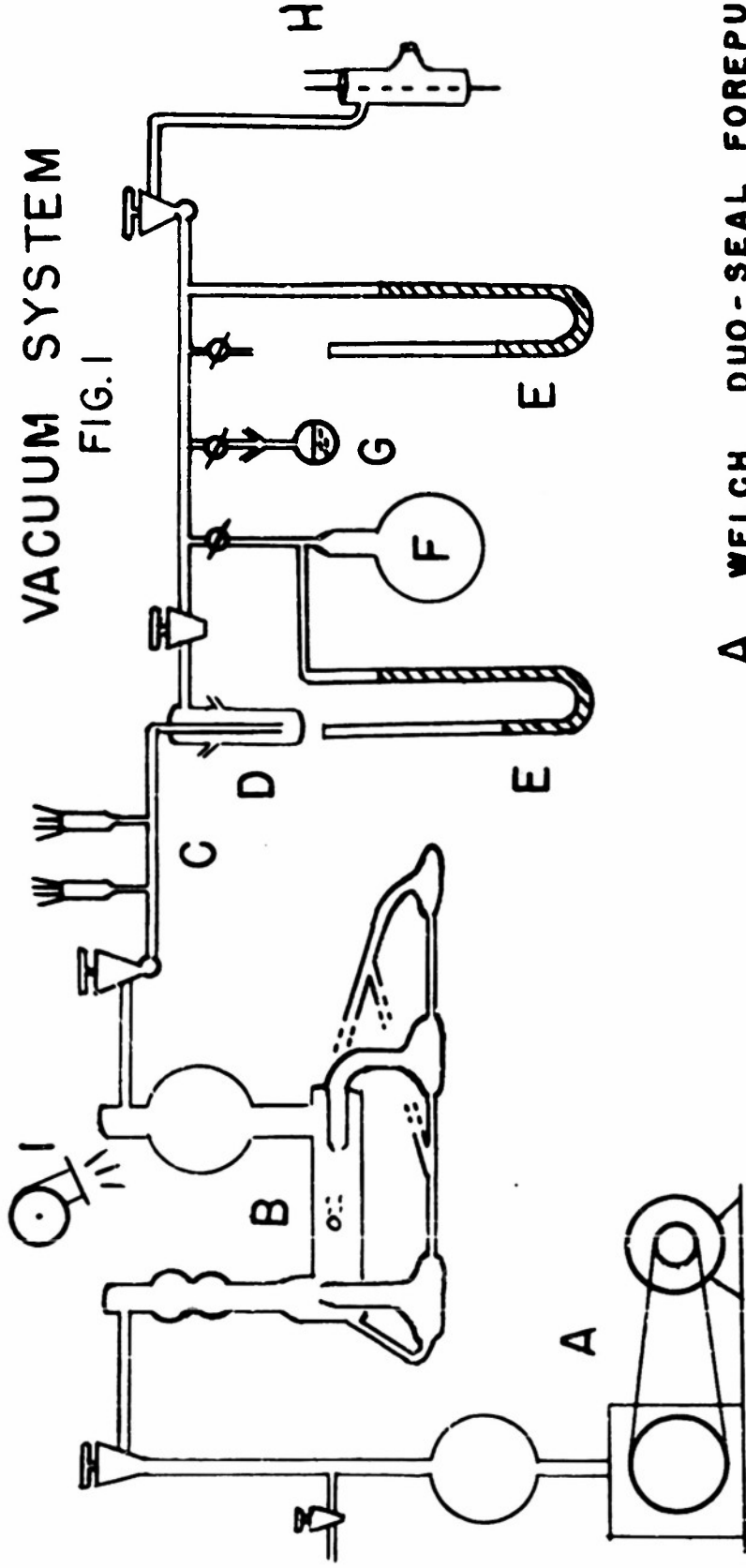

- A WELCH DUO-SEAL FOREPUMP
- B OIL DIFFUSION PUMP
- C R.C.A. 1946 & D.P.I. VG-1A GAUGES
- D LIQUID AIR TRAP
- E MERCURY MANOMETERS
- F GAS RESERVOIR
- G VAPOR RESERVOIR
- H GEIGER COUNTER
- I BLOWER

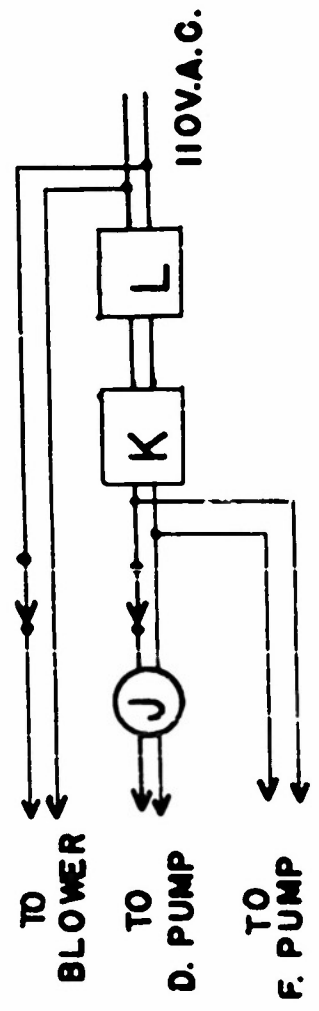

- J VARIAC
- K MAGNETIC STARTER
- L THERMAL OVERLOAD

BLOCK DIAGRAM

FIG.2

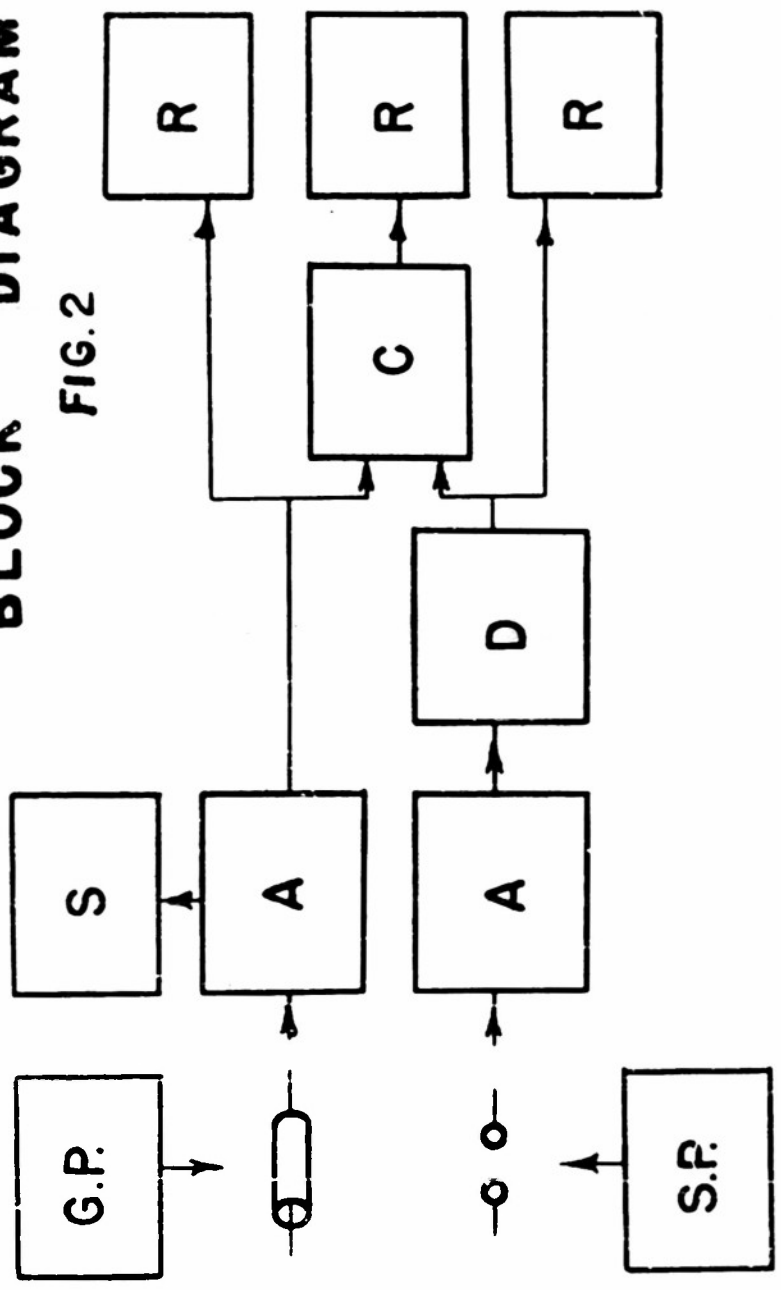

- G.P. GEIGER POWER SUPPLY
- S.P. SPARK "
- A AMPLIFIERS (WITH PRE AMPS)
- D VARIABLE DELAY LINE
- C SHAPERS, COINCIDENCE, & DISCRIMINATOR
- R PULSE LENGTHENERS & RECORDERS
- S OSCILLOSCOPE

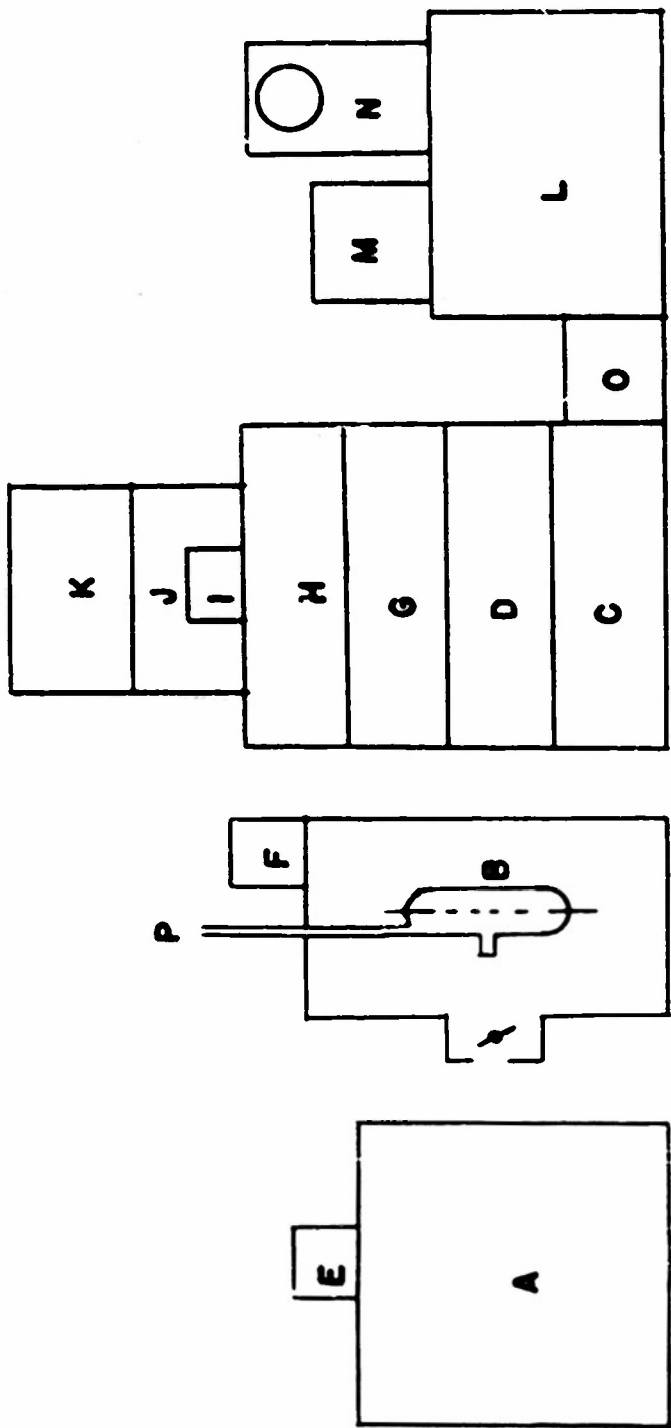

FIG. 3 PHYSICAL ARRANGEMENT

- | | | | |
|---|-------------------------|---|--------------------|
| A | SPARK | I | DISCRIMINATOR |
| B | GEIGER TUBE | J | DISC. POWER SUPPLY |
| C | AMP. POWER SUPPLY | K | " |
| D | MAIN AMPLIFIERS | L | GEIGER " |
| E | SPARK PRE-AMP. | M | DELAY LINES |
| F | GEIGER " | N | OSCILLOSCOPE |
| G | SHAPERS & COINCIDENCE | O | AUTOMATIC CUTOFF |
| H | PULSE LENG. & RECORDERS | P | TO VACUUM SYSTEM |

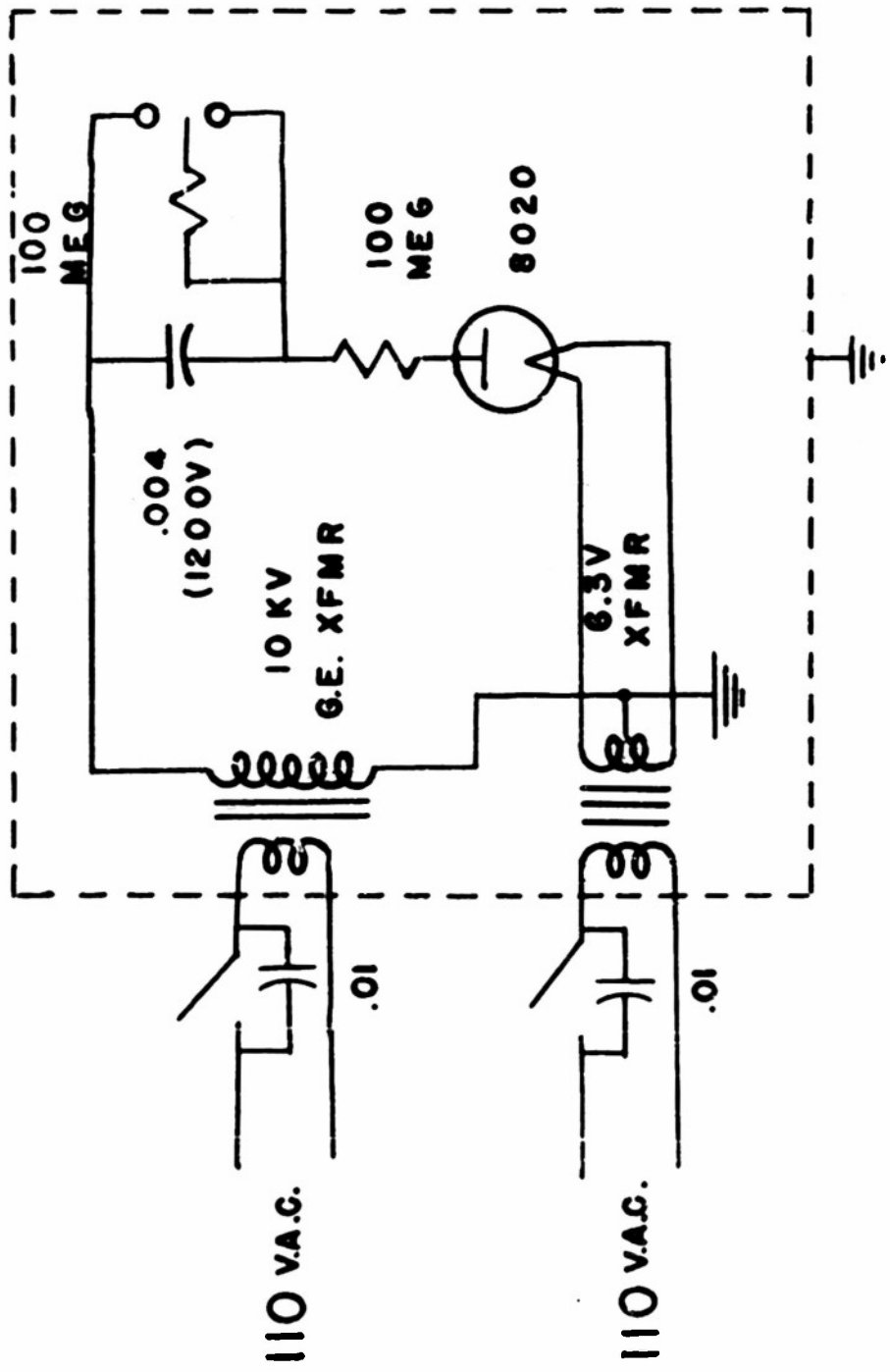

FIG.4 SPARK CIRCUIT

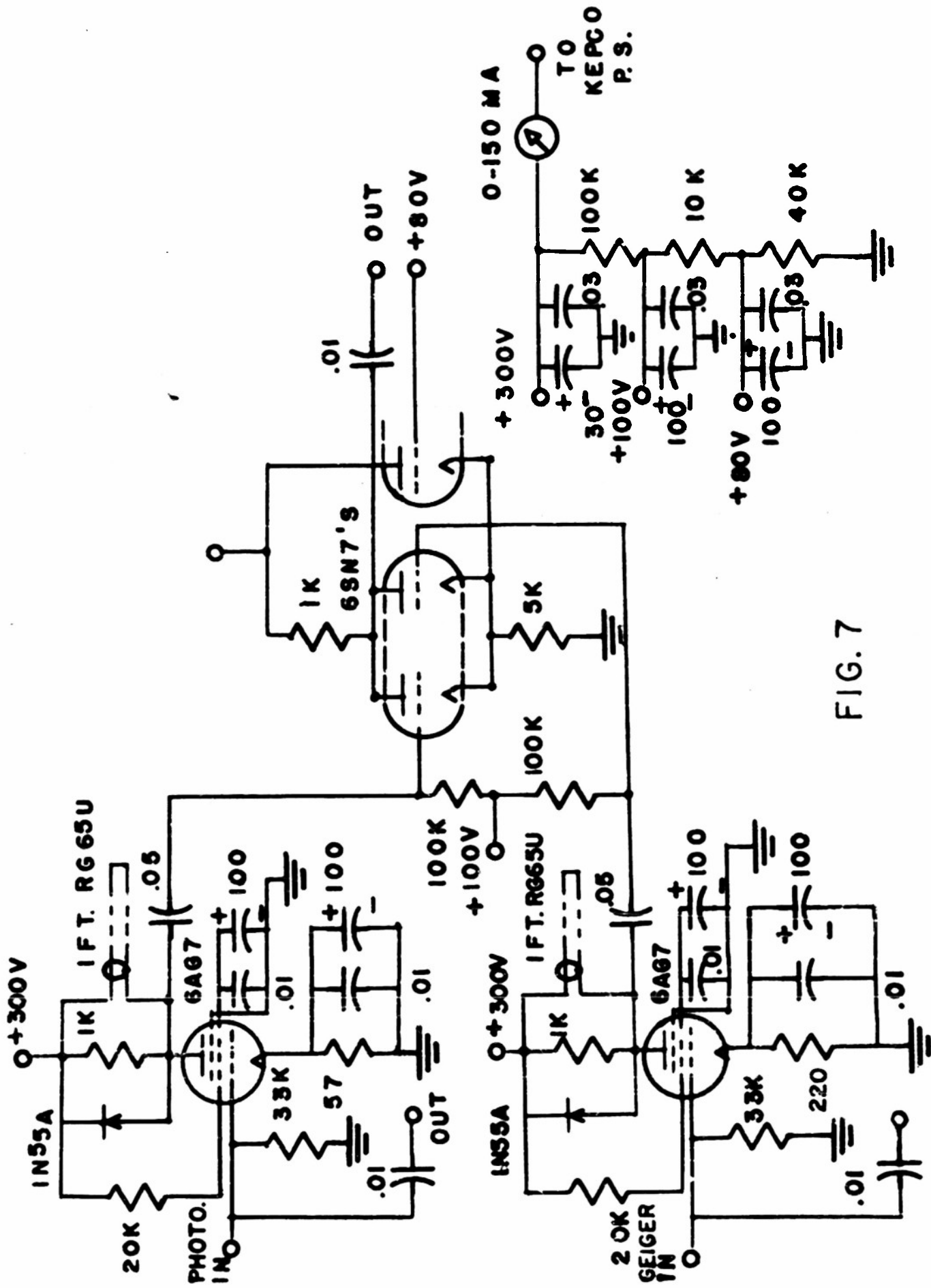
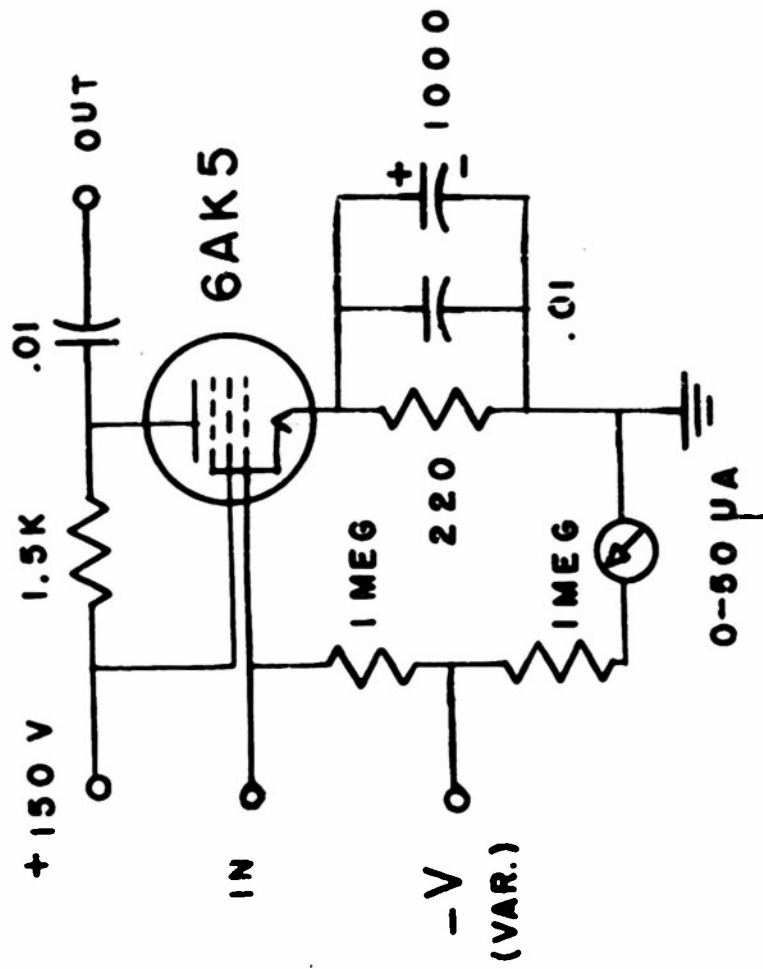

FIG. 7



DISCRIMINATOR

FIG. 8

PULSE LENGTHENER & TYPICAL RECORDER

FIG. 9

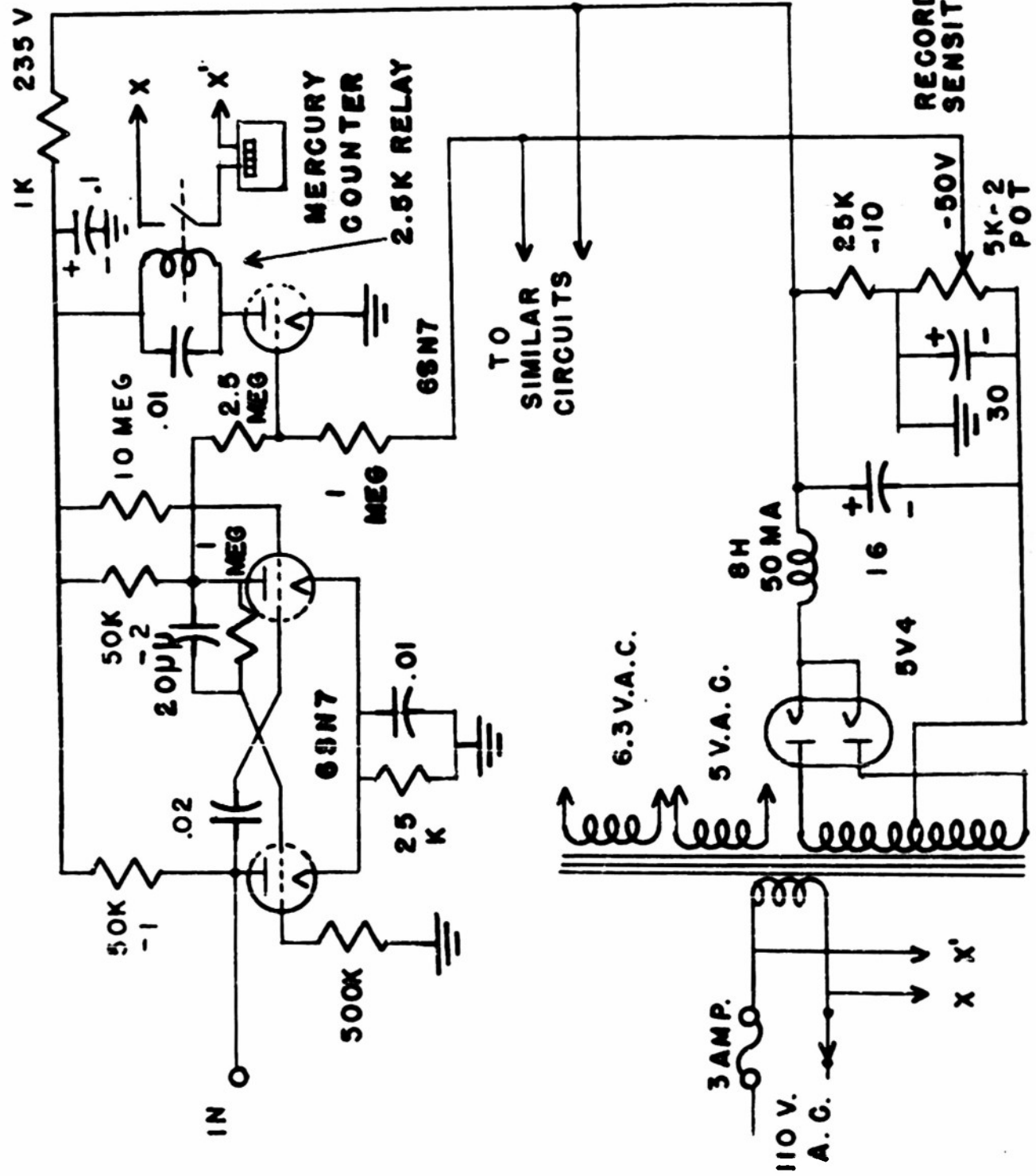

RECORDER
SENSITIVITY

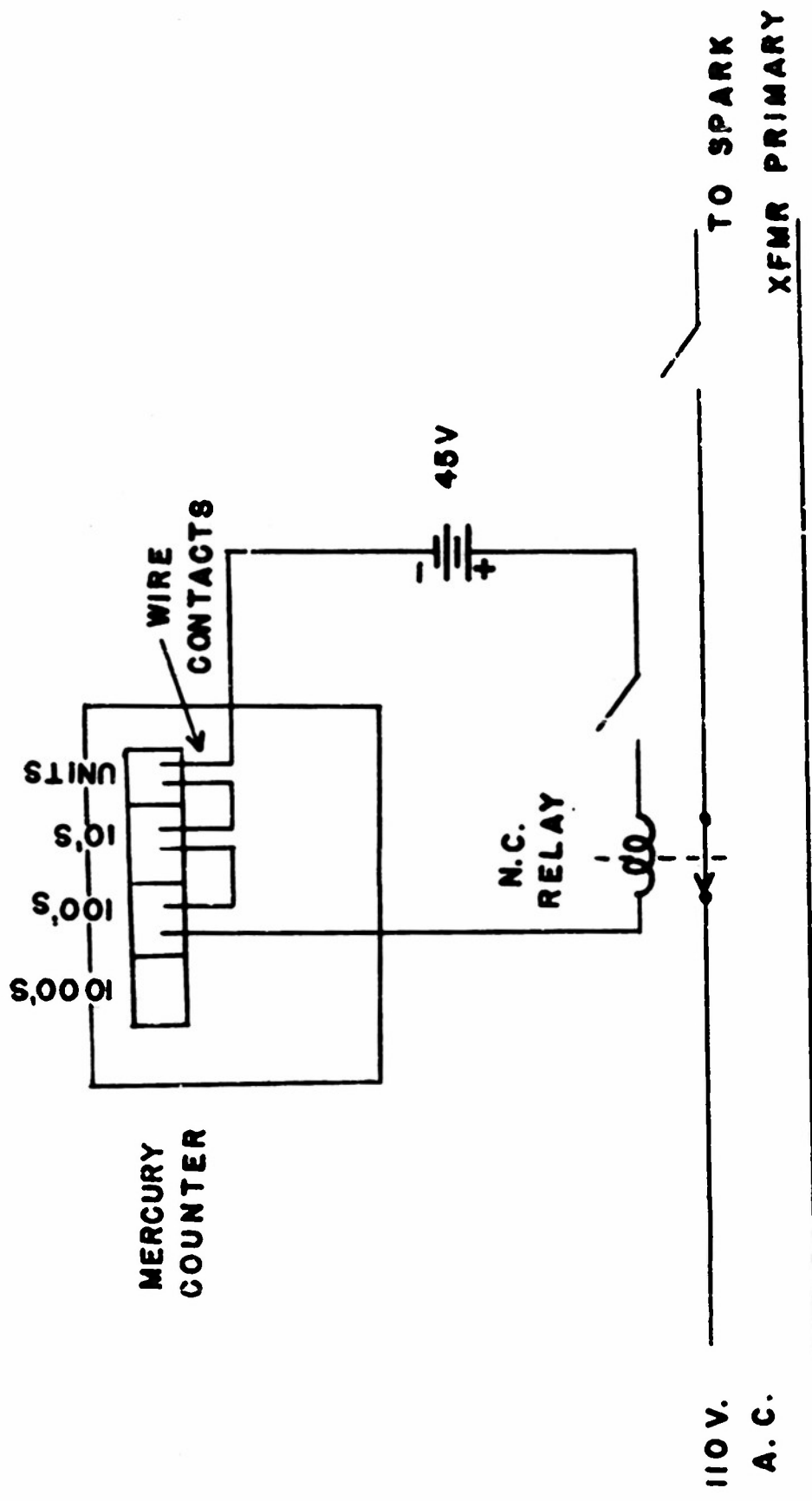

AUTOMATIC CUTOFF CIRCUIT

FIG.10.

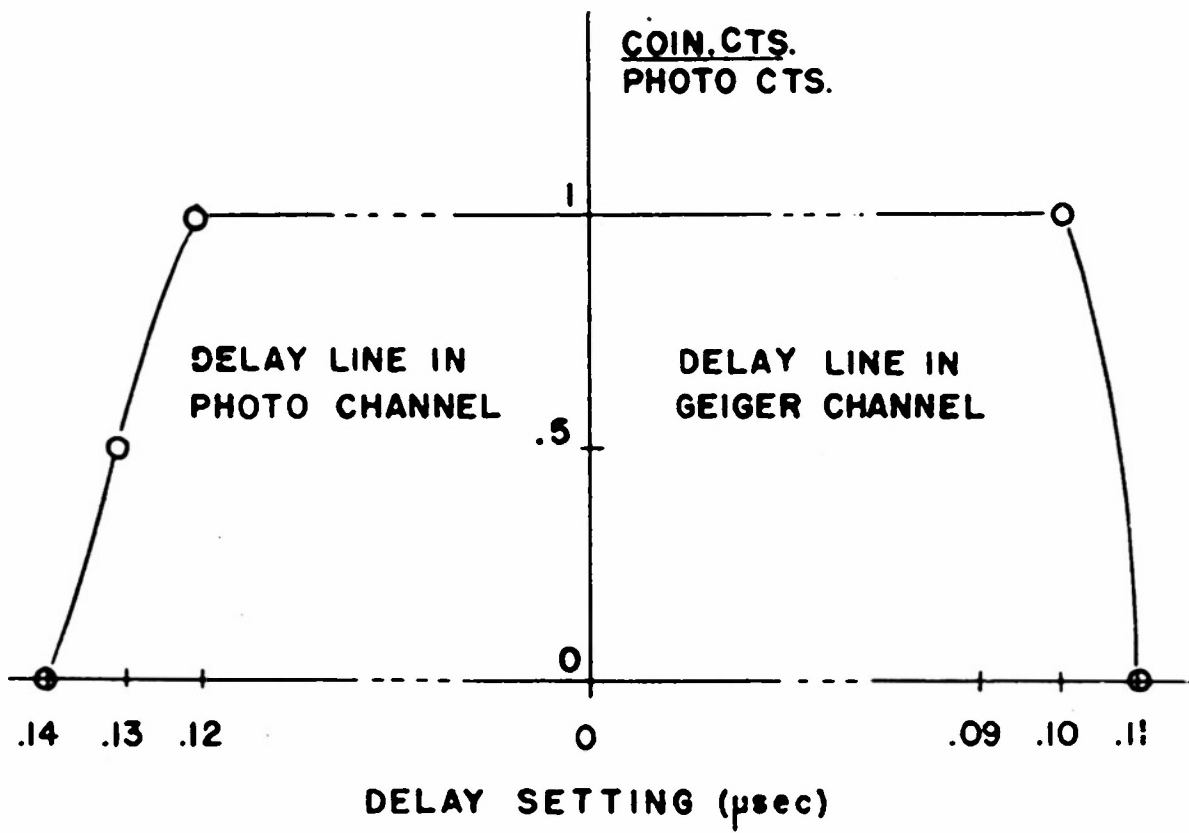

RESOLUTION OF COINCIDENCE
CIRCUIT

FIG. 10A

PART III

PRESENTATION OF DATA

The measurements of time lags that were made are presented on the immediately following pages in graphic and tabular form. The graphs are, perhaps, more instructive, but because the measured points do not always fall on a smooth curve the tables of value are given also.

The counters, except the large ones, were filled with spectroscopically pure argon, and one of several quenching vapors. The larger counters contained tank argon, which is 99.6% argon, with nitrogen as the dominant impurity. The vapors used are the ones usually used in selfquenching counters, namely, ethyl alcohol, petroleum ether, ethyl ether, and amyl acetate. Two sizes of cathodes were used in measurements with argon-alcohol fillings to give some indication of how the lag depended on counter geometry.

The fillings with amyl acetate are for rather low pressure; the vapor pressure of amyl acetate is only 5 mm Hg at 23.7 °C and is up to 10 mm at 35.2 °C¹⁸. Isoamyl acetate and n-amyl acetate have about the same vapor pressure; it was the isoamyl acetate that was used here. The vapor pressure of amyl acetate was measured by the author and found to be the value given above. The two fillings of amyl acetate, it will be seen, have the same pressure of acetate vapor in them.

Petroleum ether has been used in counters by persons at California Institute of Technology, and elsewhere, and so it was decided to test it as a quenching vapor here. It should be pointed out that the liquid called petroleum ether is not composed of similar molecules, but a

¹⁸ D. R. Scoll, Indus. Eng. Chem. 39, 517 (1947).

mixture of several. The analysis of petroleum ether will vary from one sample to the next.

Several interesting things will be observed from the curves. The first is that the slope of the curves increases with overvoltage. From the two curves for the larger counter (Figs. 11 and 12) it is evident that the lag is quite sensitive to percentage of alcohol in the filling, although this is not evident for the smaller counters (Fig. 13). Another important thing is that, among the small counters, nearly all of the lags are in the range of from 0.4 to 0.95 microseconds, except ethyl ether which is shorter, and in the range of from 0.35 to 0.45 microseconds.

The chemical formulae and molecular weight of the quenching vapors, where they can be given, are in Table II:

TABLE II
CHEMICAL FORMULAE AND MOLECULAR
WEIGHT OF VAPORS

<u>Vapor</u>	<u>Stereoformula</u>	<u>Numerical formula</u>	<u>Molecular Weight</u>
Amyl Acetate	$\text{CH}_3\text{CO}_2\text{C}_5\text{H}_{11}$	$\text{C}_7\text{H}_{14}\text{O}_2$	130.18
Ethyl Alcohol	$\text{CH}_3\text{CH}_2\text{OH}$	$\text{C}_2\text{H}_6\text{O}$	46.07
Ethyl Ether	$\text{C}_2\text{H}_5\text{OC}_2\text{H}_5$	$\text{C}_4\text{H}_{10}\text{O}$	74.12

The iso- and n-amyl acetate have the same chemical formulae but the molecular structure is slightly different. The acetate has by far the most atoms and the greatest molecular weight of those vapors used, while the alcohol has the least number of atoms to the molecule and the smallest molecular weight.

TABLE III

ETHYL ALCOHOL AND ARGON

14 cm. Total Pressure

Overvoltage (volts)	Most Probable Lag (microseconds)		
	5% Alcohol	10% Alcohol	20% Alcohol
0	1.92	2.95	4.45
50	1.70	2.79	4.05
100	1.55	2.50	3.95
150	----	2.45	3.79

Geiger threshold: 1040 volts for 5% Alcohol.

1190 volts for 10% Alcohol.

1540 volts for 20% Alcohol.

Cathode Diameter 6 cm.

Central Wire 3 mils.

TABLE IV

10% ETHYL ALCOHOL AND 90% ARGON

Overvoltage (volts)	Most Probable Lag (microseconds)		
	10 cm Tot. Press.	12 cm Tot. Press.	14 cm Tot. Press.
0	2.30	2.65	2.95
50	2.15	2.45	2.77
100	1.85	2.34	2.50
150	1.77	2.15	2.45
200	1.70	----	----

Geiger Thresholds: 1040 volts at 10 cm.

1140 volts at 12 cm.

1190 volts at 14 cm.

Cathode Diameter 6 cm.

Central Wire 3 mils.

TABLE V
 ETHYL ALCOHOL AND ARGON
 14 cm Total Pressure

Overvoltage (volts)	Most Probable Lag (microseconds)		
	5% Alcohol	10% Alcohol	20% Alcohol
0	1.15	1.05	0.98
50	0.58	0.70	0.70
100	0.53	0.50	0.60
150	0.45	0.46	0.50
200	----	----	0.45

Geiger Thresholds: 890 volts for 5% Alcohol.

1040 volts for 10% Alcohol.

1200 volts for 20% Alcohol.

Cathode Diameter 7/8 inch.

Central Wire 3 mils.

TABLE VI

10% ETHYL ALCOHOL AND 90% ARGON

Overvoltage (volts)	Most Probable Lag (microseconds)		
	10 cm Tot. Press.	12 cm Tot. Press.	14 cm Tot. Press.
0	0.95	0.75	1.05
50	0.60	0.63	0.70
100	0.55	0.55	0.50
150	0.53	0.45	0.46
200	0.51	----	----

Geiger Thresholds: 1020 volts at 10 cm.

1020 volts at 12 cm.

1040 volts at 14 cm.

Cathode Diameter $7/8$ inch.

Central Wire 3 mils.

TABLE VII

10% PETROLEUM ETHER AND 90% ARGON

Overvoltage (volts)	Most Probable Lag (microseconds)		
	8 cm Tot. Press.	10 cm Tot. Press.	12 cm Tot. Press.
0	0.87	0.70	0.85 (at 20v)
50	0.66 (at 45v)	0.70	0.75
100	0.65	0.52	0.65
150	0.49	0.50	0.55
200	0.45	0.50	0.50

Geiger Thresholds: 840 volts at 8 cm.

920 volts at 10 cm.

980 volts at 12 cm.

Cathode Diameter $7/8$ inch.

Central Wire 3 mils.

TABLE VIII

10% ETHYL ETHER AND 90% ARGON

Overvoltage (volts)	Most Probable Lag (microseconds)	
	8 cm Tot. Press.	10 cm Tot. Press.
0	0.44	0.44
50	0.36	0.40
100	0.36 (at 90v)	0.38

Geiger Thresholds: 870 volts at 8 cm.

840 volts at 10 cm.

Cathode Diameter 7/8 inch.

Central Wire 3 mils.

TABLE IX
 AMYL ACETATE AND ARGON

Overvoltage (volts)	Most Probable Lag (microseconds)	
	5% Amyl Acetate 6 cm Tot. Press.	10% Amyl Acetate 3 cm Tot. Press.
0	0.95	0.64
50	0.54	0.44
100	0.45	0.34
150	0.40 (at 140v)	----

Geiger Thresholds: 720 volts at 6 cm.

580 volts at 3 cm.

Cathode Diameter 7/8 inch.

Central Wire 3 mils.

PART IV

DISCUSSION OF RESULTS

A. Distribution of Delays.

The actual distribution of delays plays quite a practical role when measuring short time intervals by delayed coincidence methods using Geiger counters, as often happens in measuring the lifetime of mesons¹⁹ or the lifetime of short lived isotopes²⁰. Most workers assume that for given counter conditions the distribution is Gaussian, although Nag, et. al., expresses some doubt about this assumption.

The present method of measuring time lags was developed in an attempt to shed some light on this question. The ratio of coincidence counts, at a given delay setting, to total sparks gives a measure of the probability of a Geiger pulse being delayed by the amount of the delay setting. As the delay setting was varied the probability was found to reach a peak. Such a curve of percentage coincidences vs delay setting is shown in Fig. 18. The resolution of the coincidence circuit was 0.22 microseconds and so it must be remembered that each point on the measured curve of Fig. 18 represents an integration of an actual distribution curve from a time of the setting plus about 0.10 microseconds to a time of the setting minus about 0.12 microseconds. Therefore the half-width of the curve in the figure (0.29 microseconds) corresponds to an actual half-width of about 0.07 microseconds, or perhaps a few hundredths of a microsecond more because of the slight

¹⁹ B. Rossi and N. Nereson, *Phys. Rev.* 62, 417 (1942),
F. Rasetti, *Phys. Rev.* 60, 198 (1941).

²⁰ A. Lundby, *Forsvarets Forskningsinstitut Arbok 1948-49*, p. 29,
D. Binder, *Phys. Rev.* 76, 856 (1949),
B. D. Nag, S. Sen, and S. Chatterji, *Ind. J. Phys.* 24, 261 (1950).

uncertainty in the resolving time of the coincidence circuit. The curve shown is for one of the larger counters and so has its peak at a relatively long time lag. For smaller counters and at high over-voltages the distribution curve is very similar but, of course, the side toward shorter times must drop to zero coincidences at zero time. The half-width of the distribution curve with even the shortest lags about the same as the half-width of the distribution curve shown in Fig. 18.

Some persons²¹, in the course of other work, have made measurements of the distribution of lags under conditions similar to this work. Laufer's typical distribution indicates a half-width of about 0.1 microseconds, and an r.m.s. deviation of about 0.2 microseconds, while den Hartog, et. al., have an r.m.s. deviation of about 0.3 microseconds. Since Laufer's work was done under conditions more closely related to the present work, it is reasonable to expect that the author's value of 0.07 microseconds for the half-width would be in agreement with Laufer's.

After it was found that the shape of the distribution curves was not noticeably different for various most probable lags accurate data was taken for the peak of the curves and a search was made to see if there were any irregularities in the distributions. None were found.

In looking for a reason for the observed distribution of delays, one might first think of the duration of the light flash from the spark. a photon from one instant of the spark of finite duration could initiate

²¹ A. R. Laufer, N.Y.U. Thesis, 1949,
E. Rossi and N. Nereson, op.cit,
H. den Hartog, F. A. Muller, and N. F. Verster, op. cit.

the photo pulse and an earlier or later photon eject the photoelectron in the Geiger counter. Using the circuit shown in Fig. 19, the current from the photocell was observed as a function of time. The results are presents on the graph of Fig. 19. The circuit constants were chosen so as not to affect the shape of the pulse. The full light from the spark was allowed to fall on the Geiger counter to increase the probability of ejecting a photoelectron. As a result, more than one photoelectron may have been ejected, but all electrons after the first that arrive at the avalanche region will merely contribute to the avalanche. The probability that any electrons became attached to form negative ions was very small with the gases used in this experiment. Also, Laufer has shown that the distribution was not noticeably affected by large changes in the light intensity. The geometry of the apparatus, the intensity of light, and the attachment probability of the gases was about the same here as in Laufer's work.

Consider next whether the light of the spark was truly instantaneous. The intensity of light was measured and found to reach a maximum after a very short time (see Fig. 19) and fell to about half this maximum value after 0.2 microseconds. The probability that an electron was ejected was proportional to the number of photons striking the cathode. The light intensity curve could account for some, but not all, of the spread in lags. The lags shown in the distribution curve (Fig. 18) extend from 1.4 microseconds to about 1.9 microseconds when the resolving time of the coincidence circuit is taken into account. Although the light from the spark does extend about this interval of 0.5 microseconds, an asymmetrical distribution, like the light intensity distribution of Fig. 19, would be expected if the duration of the spark was

the sole cause of the distribution of lags. Because the lag distribution curve was not asymmetrical it is more probable that the ionizing event in the counter occurred very near the beginning of the spark, when the light intensity was greatest.

Another effect which possibly could have caused a spread of lags was the influence of "impurities" in the counter gas. These "impurities" are fragments of the organic quenching molecules, and will be present in ever increasing amounts after the very first discharge. The mobility of an electron in a gas is affected quite strongly by some impurities, as will be mentioned again later. A second, but in these tests rather improbable, effect of these "impurities" is the capture of the electron if the fragments are electronegative. The fragment will then be a negative ion, with large mass, and move very slowly. Studies by other persons give an estimate of the time lags to be expected when capture occurs and these lags are many microseconds, or tens, or even hundreds of microseconds. In view of these facts it seems that capture must be ruled out.

In summary, then, we conclude that the distributions are approximately Gaussian, or Poisson if the most probable lag is short.

B. The Time Interval Measured.

In the interval of time between the ionizing event and the recording of the Geiger pulse three separate events may occur. First, the electron will migrate toward the central wire and create the first Townsend avalanche. Second, the discharge will spread down the wire; and third, the sheath of positive ions left around the wire will start to move out to the cylinder. The potential on the wire cannot start to drop until the electrons from the first avalanche reach the wire and start to leak

off, but thereafter the potential will continue to change while the discharge is spreading down the wire and the positive ions are moving out. These last two events start to occur simultaneously for the positive ion motion is slow. If the amplifiers have enough gain and a fast enough rise time the pulse can be detected as soon as the initial avalanche reaches the wire, since only a few electrons need to leak off to give maximum output from the Geiger amplifier. The time of formation of the initial avalanche is extremely small, about 10^{-10} seconds²².

A rough sketch of the Geiger pulse, at the Geiger tube, appears in Fig. 20, and on the same diagram is the pulse after it has been amplified, the amplifier saturating at 40 volts. A one volt input pulse would be 10^5 volts in amplitude as it left the amplifier if the amplifier did not saturate! The Geiger pulse at the Geiger tube will reach its maximum amplitude after a time of no more than 10 microseconds. By a simple geometrical ratio it can be seen that the time "t" in the figure, the time that the amplified pulse will reach its maximum value, will be about 0.004 microseconds. Using a typical velocity of discharge spread down the wire of 10 cm per microsecond, the discharge can have moved down the wire a distance of 0.04 cm before the pulse has reached its maximum height. The amplified pulse will also be made steeper in the shaping circuits. Considering these facts it can safely be said that the time measured was the transit time of the electron from the cylinder to the central wire.

C. Electron Mobilities.

It is desirable to check our measured lags with the drift velocity

²² S. A. Korff, Phys. Rev. 72, 477 (1947),
D. H. Wilkinson, Ionization Chambers and Counters (Cambridge University Press, Cambridge, 1950), p. 195.

of electrons in electric fields. A true mobility constant k , as appears in the equation $v = k(E/p)$, where v is velocity, E electric field, and p the pressure, does not exist for the gas mixtures and electric fields encountered here. Usually when ions are moving through a gas, the relation $v = k(E/p)$ is used for low values of E/p and the relation $v = k(E/p)^{1/2}$ is used for higher values of E/p , the transition region depending upon the gas involved. With electrons moving through a gas, a plot of v vs E/p would usually be a straight line of slope k for very low values of E/p , then be approximated by $v = k(E/p)^{1/2}$, and finally the curve levels off to a constant value of v for still moderately low values of E/p . The behavior with high values of E/p , such as exist near the central wire in a Geiger counter, not been investigated. Values of E/p for our 7/8 inch diameter counter range from about 1.5 volts/cm/mm Hg at the cathode to about 400 near the wire (increasing as $1/r$). The largest values of E/p used in mobility measurements are of the order of 10 volts/cm/mm Hg for electrons moving through a gas.

Nearly all of the mobility measurements existing in the literature are for electrons moving through a pure gas. The situation is complicated when the electron moves through a mixture of two gases, or through a gas and vapor mixture. Rossi and Staub²³ have shown that the velocity that an electron has in argon at a given E/p , or in CO_2 for the same E/p , are much lower than the velocity in an argon- CO_2 mixture at the same E/p . Colli and Facchini²⁴ observed the same effect in an argon- CO_2 Geiger counter. Also they, among others, have noted that impurities greatly affect the mobility. Nitrogen, as an

²³ B. Rossi and H. H. Staub, Ionization Chambers and Counters (McGraw-Hill Book Company, Inc., New York, 1949), Chapt. 1.

²⁴ L. Colli and U. Facchini, Rev. Sci. Inst. 23, 39 (1952).

impurity, can change the mobility by several orders of magnitude, as was shown by Kirshner and Toffolo²⁵. Commercial grade (tank) argon usually has nitrogen as an impurity, and spectroscopically pure argon was used by the author, for all the small counters, for this reason.

One measurement has been made recently of the mobility of electrons in an argon-ether mixture²⁶. The data from this paper of Stevenson is given in Fig. 21. It should be emphasized that there are many "impurities" in our counter after the first pulse, due to the fragments of the quenching molecules. Stevenson's measurements were made with electron-multiplication devices and these "impurities" play a role in his measurements of the velocity of the electrons.

Most investigators of time lags in Geiger counters have assumed a velocity for the electron given by the linear relation $v = k(E/p)$. They reasoned that the electron velocity will continuously increase, the electron will spend most of the time in the region of low E/p , and the relation $v = k(E/p)$ could be used even though there might be some deviations from this equation in the higher field regions. The work of Stevenson has shown that the above line of reasoning is not correct.

To calculate the time lag expected in a time lag experiment the time lag (t) should be thought of as consisting of two consecutive time intervals. During the first time interval (t') the electron will be traversing a region where $v = k(E/p)$ and during the second time

²⁵ A. Stevenson, Rev. Sci. Inst. 23, 93 (1952).

²⁶ J. M. Kirshner and D. S. Toffolo, J. App. Phys. 23, 594 (1952).

interval (t'') v will be constant. It can be shown that the time interval t' is given by the equation²⁷

$$t' = \frac{pr'^2 \ln(r_c/r_a)}{2kV},$$

where r' = distance covered in time t' ,

r_c = cathode radius,

r_a = anode radius,

k = mobility, or slope of the linear portion
of the v vs E/p curve, in $\text{cm}^2/\text{mm}/\text{secV}$,

V = operating voltage,

p = pressure in mm Hg.

The time interval t'' is simply $t'' = r''/v_c$, where r'' is the distance covered in time t'' , and v_c is the constant velocity during t'' . The time for an electron to cross the counter is then

$$t = t' + t'' = \frac{pr'^2 \ln(r_c/r_a)}{2kV} + \frac{r''}{v_c}. \quad \text{Eq. (1)}$$

We can check the time lag in our ether-argon counter with this formula. With a 10% ether and 90% argon filling at a total pressure of 10 cm we have the following conditions:

Geiger threshold = 840 volts,

Overvoltage = 50 volts,

r_c = 1.15 cm,

r_a = 3.8×10^{-3} cm,

p = 100 mm.

From the curve of Fig. 21 we see that $k = 3.68 \times 10^6 \text{ cm}^2/\text{mm}/\text{secV}$, and v becomes constant at an E/p of about 2.2 volts/cm/mm, which corresponds

²⁷ H. den Hartog, F. A. Muller, and N. F. Verster, op. cit.

to a value of r'' of 0.39 cm. Then we have

$$r'' = 0.39 \text{ cm,}$$

$$r' = 0.76 \text{ cm,}$$

$$k = 3.68 \times 10^6 \text{ cm}^2\text{mm/secV,}$$

$$v_c = 8 \times 10^6 \text{ cm/sec.}$$

If these values are put in Eq. (1), we find

$$t = 0.097 \times 10^{-6} + 0.049 \times 10^{-6} = 0.146 \times 10^{-6} \text{ sec.}$$

The measured value of the time lag in the above case was 0.4×10^{-6} seconds, and is of the same order of magnitude as the calculated value. Better agreement cannot be expected in view of the "impurities" which exist in the counter.

As this study was being completed Colli and De Leonardis²⁸ published curves of v vs E/p for alcohol-argon mixtures. They used 10% alcohol mixtures at a total pressure of 15 and 30 cm and 5% alcohol mixtures at 15 cm, 36 cm, and 40 cm total pressures. For the 10% alcohol mixtures the velocity increased quite linearly with E/p up to a value of E/p of 2.0 volts/cm/mm, at which point the velocity became constant at 4.7×10^6 cm/sec. Several comments should be made on this data of Colli and De Leonardis. The first is that the curve does not seem to pass through a region where the equation $v = k(E/p)^{1/2}$ is obeyed, as did the ether-argon curve of Fig. 21. The region where $v = k(E/p)$ goes directly into the region where v is constant. Also, the beginning of the region where v is constant is at a slightly lower value of E/p than the beginning of this same region for Stevenson's ether-argon mixture. A third fact is that the constant value of v for the alcohol-argon mixture is about one half the constant value of v for the ether-

²⁸ L. Colli and M. T. De Leonardis, J. App. Phys. 24, 255 (1953).

argon. This fact is borne out in the present work by a comparison of the lags measured in alcohol-argon and ether-argon counters (Figs. 14 and 16 respectively). The lags in the author's ether-argon counter are shorter.

A very important result of the work of Colli and De Leonardis was an increased knowledge of the behavior of the v vs E/p curve with variations in the total pressure and percentage of alcohol. Using a 10% alcohol mixture they found that there was not any change in the v vs E/p curve when the total pressure was varied from 15 cm to 30 cm. Likewise there was no change in the v vs E/p curve for a 5% alcohol filling when the total pressure was changed from 15 cm to 40 cm. The curves of the 10% alcohol filling were very similar to the curves of the 5% alcohol filling. These results are in agreement with our measured values of time lags shown in Figs. 13 and 14, where the partial and total pressure of the fillings are varied. Our lags are seen to have approximately the same values on these two figures.

Our time lag curves for petroleum ether-argon and amyl acetate-argon fillings are of the same general nature as the curves for alcohol-argon fillings and it can be said that the velocity of electrons through all of these three fillings is approximately the same.

D. Comparison with Other Experimental Measurements.

Laufer's method of measuring time lags was described previously (see page 11). His measurements can be compared to those of the author (see Fig. 22). The counters had the same geometry and filling in both cases. Laufer's counters had many windows along the cathode so that light could enter at several places at one time. In

this manner the discharge could be started at several points along the central wire and the lag due to the spread of the discharge down the wire minimized. When the time lag was measured in this fashion he called the measured lag "transit lag". When he covered all of the windows, except the center one (in which manner the author's experiments were made), the measured lag was called "total lag". Due to the small amplification of Laufer's Geiger pulse he stated that his measured "total lag" was not detected until the discharge had spread part of the way down the wire.

Referring to Fig. 22 it is seen that the measured data lie along two smooth curves, implying good statistical accuracy in the two experiments. The shortness of Laufer's lags would suggest the presence of nitrogen because nitrogen does increase the velocity of an electron in a given electric field. He used commercial tank argon, which has nitrogen as an impurity; the author used spectroscopically pure argon for his measured values in this figure. Also, Kitchen²⁹ states that Laufer's triggering pulse (or photo pulse) had a long rise time. These pulses would trigger the sweep of his synchroscope after the ionizing event had occurred, and so his measured lags would be shorter than the actual lags.

E. Practical Results.

Several suggestions can be made, as a result of the present study, to persons using Geiger counters in delayed coincidence measurements. When the measured time lags were compared to those measured by Laufer it was evident that commercial tank argon, instead of very pure argon,

²⁹ S. W. Kitchen, op. cit.

produced a counter with a short time lag. The work of Kirshner and Toffolo²⁶ supports this conclusion.

The present work, in conjunction with the mobility measurements of Colli and De Leonardis²⁸, shows that when pure argon-alcohol is used the time lag is quite insensitive to the partial pressure of the filling. Stevenson's mobility measurements²⁵ supported the finding that ethyl ether is somewhat better than ethyl alcohol in producing short time lags.

Another recommendation is that, regardless of the filling, counters should be operated with as high an overvoltage as possible. Lags as long as one microsecond can result with insufficient overvoltage.

VARIATION OF MOST PROBABLE LAG
WITH OVERVOLTAGE AND %E. ALCOHOL

CATHODE DIA. 6 CM
CENTRAL WIRE 3 MILLS
ETHYL ALCOHOL + ARGON
14 CM TOTAL PRESSURE

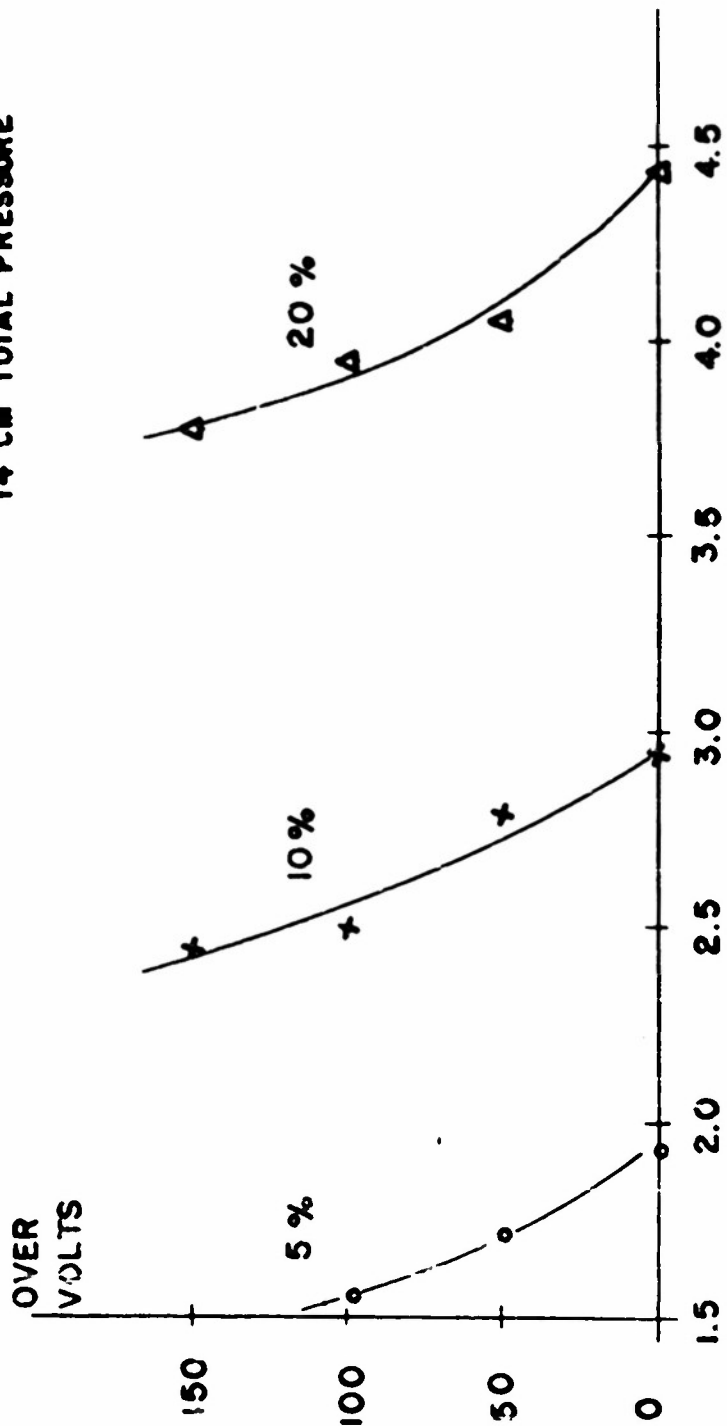

M. P. LAG (μ s)

FIG. 11

VARIATION OF M.P. LAG WITH
OVERVOLTAGE AND TOTAL PRESSURE

CATHODE DIA. 6 CM
CENTRAL WIRE 3 MILLS
10% ETHYL ALCOHOL + 90% ARGON

FIG. 12

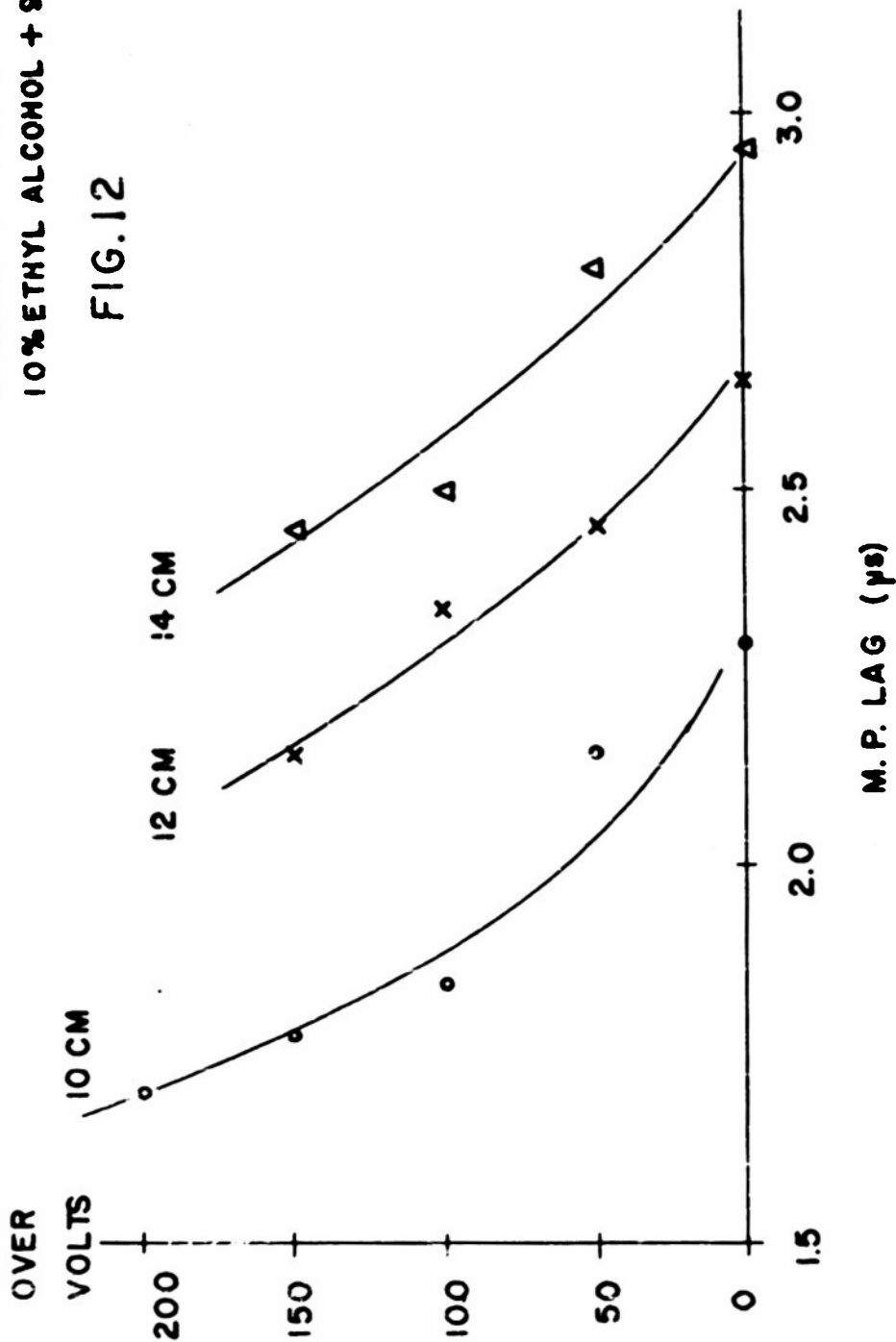

VARIATION OF M.P. LAG WITH
OVERVOLTAGE AND % ETHYL ALCOHOL
CATHODE DIA. 7/8 INCH
CENTRAL WIRE 3 MILS
ALCOHOL & ARGON
14 CM. TOTAL PRESS.

FIG. 13

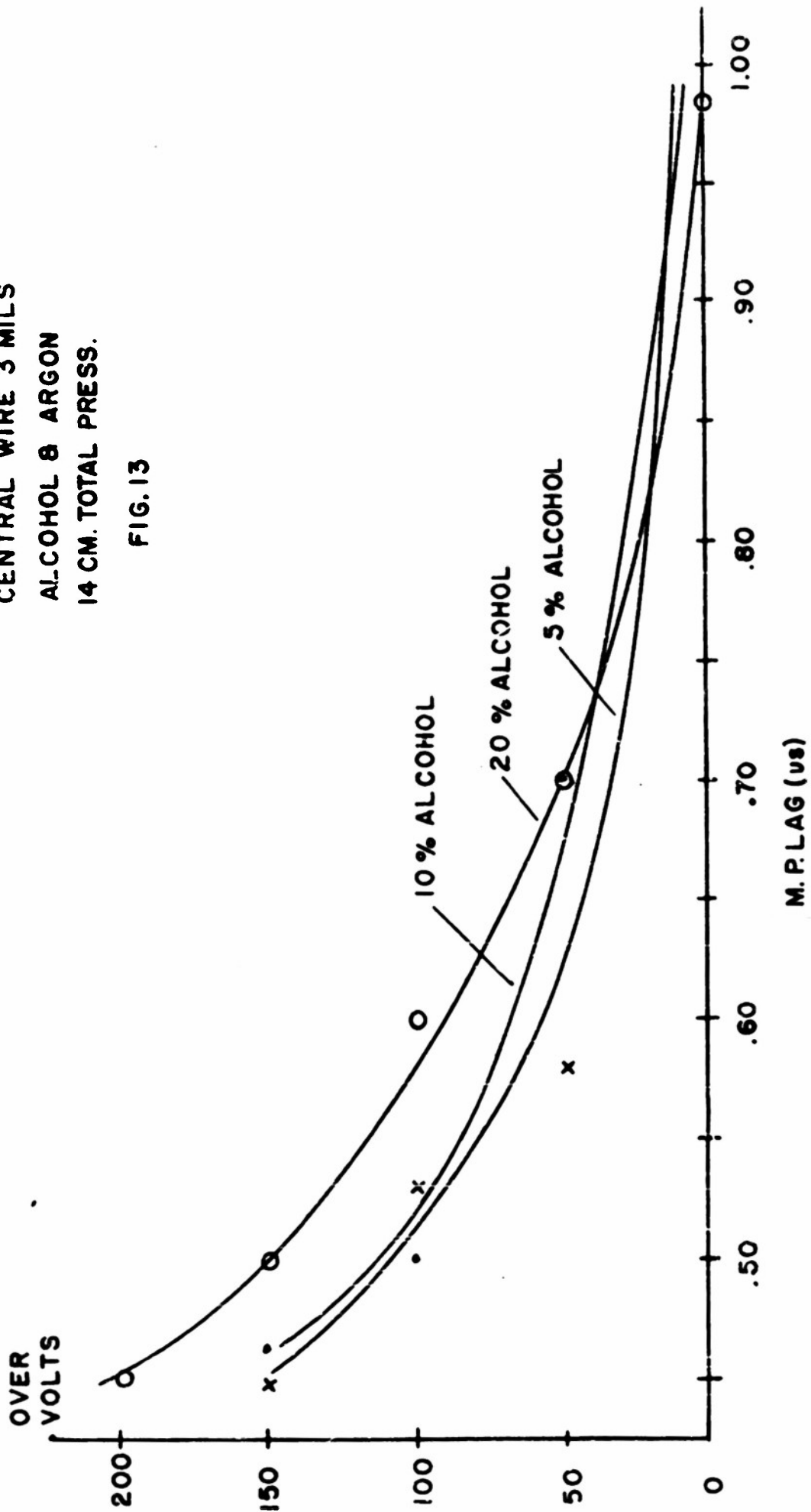

VARIATION OF M. P. LAG WITH
OVERVOLTAGE AND TOTAL PRESSURE

CATHODE DIA. 7/8 IN.
CENTRAL WIRE 3 MILLS
10% E. ALCOHOL + 90% ARGON

FIG. 14

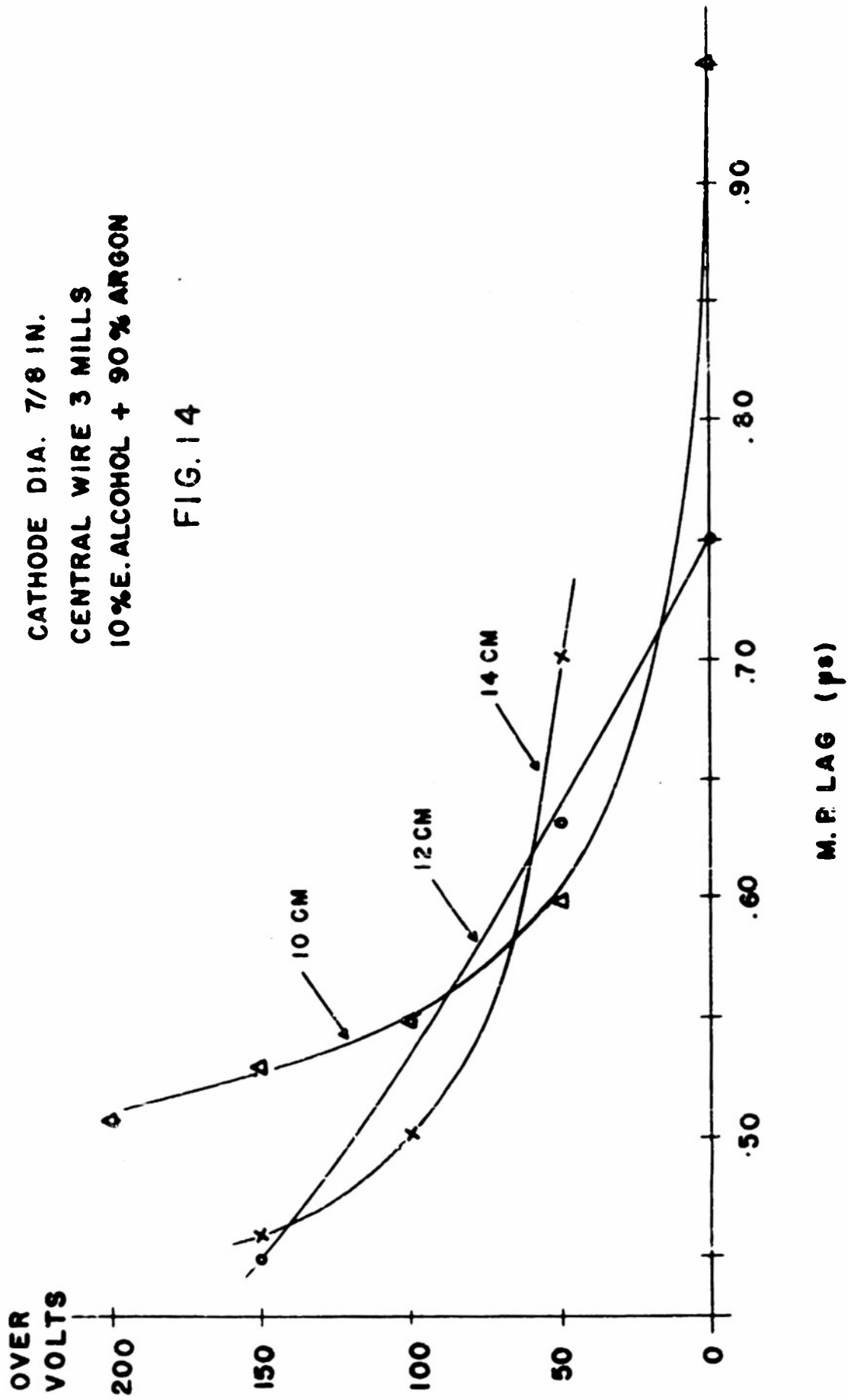

VARIATION OF M.P.LAG WITH
OVERVOLTAGE AND TOTAL PRESSURE

CATHODE DIA. 7/8 IN.
CENTRAL WIRE 3 MILLS
10% PETROL. ETHER + 90% ARGON

FIG. 15

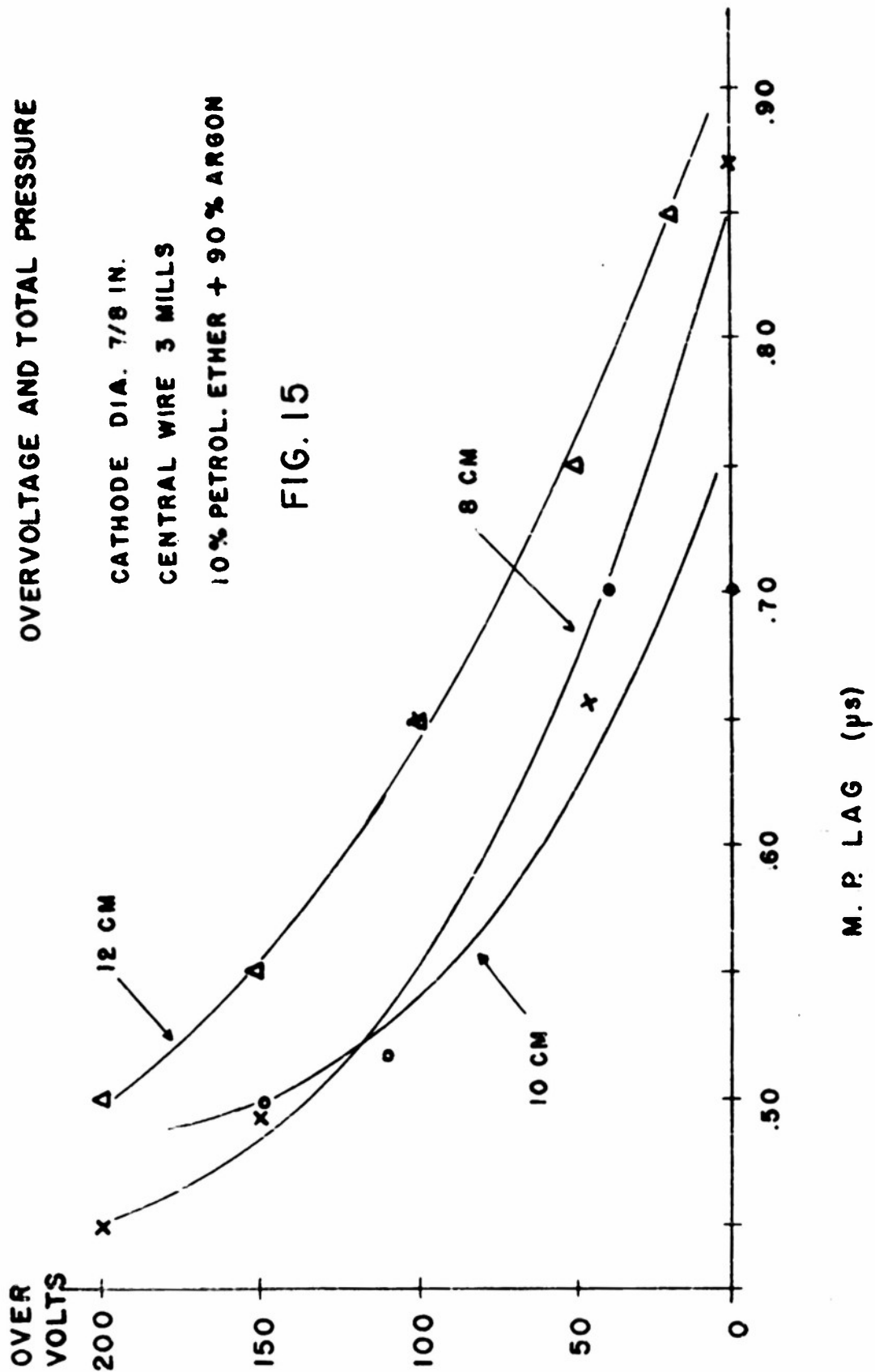

M. P. LAG (μs)

VARIATION OF M. P. LAG WITH
OVERVOLTAGE AND TOTAL PRESSURE

CATHODE DIA. 7/8 IN.
CENTRAL WIRE 3 MILLS
10% ETHYL ETHER+50% ARGON

FIG. 16

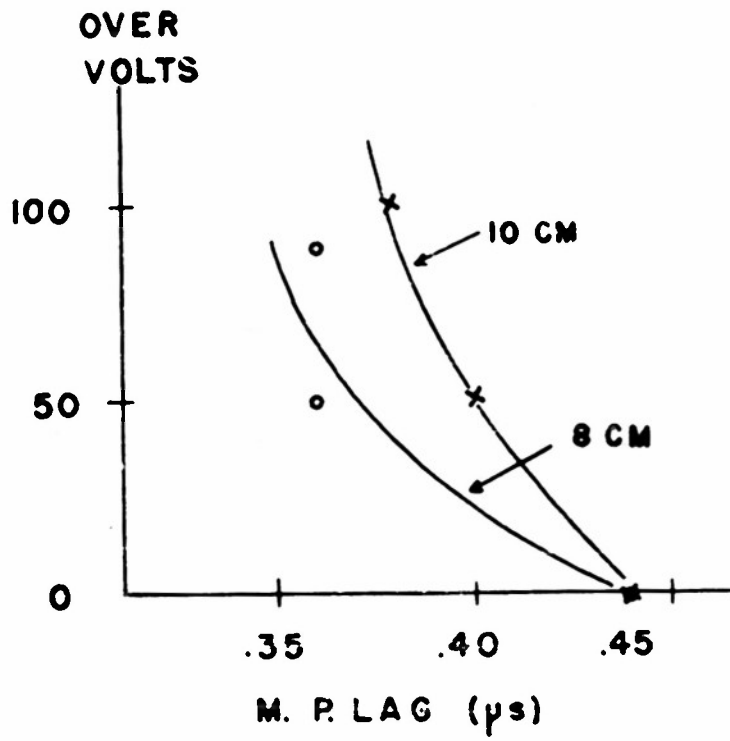

VARIATION OF M. P. LAG WITH
OVERVOLTAGE

CATHODE DIA. 7/8 IN.
CENTRAL WIRE 3 MILLS
AMYL ACETATE+ ARGON

FIG. 17

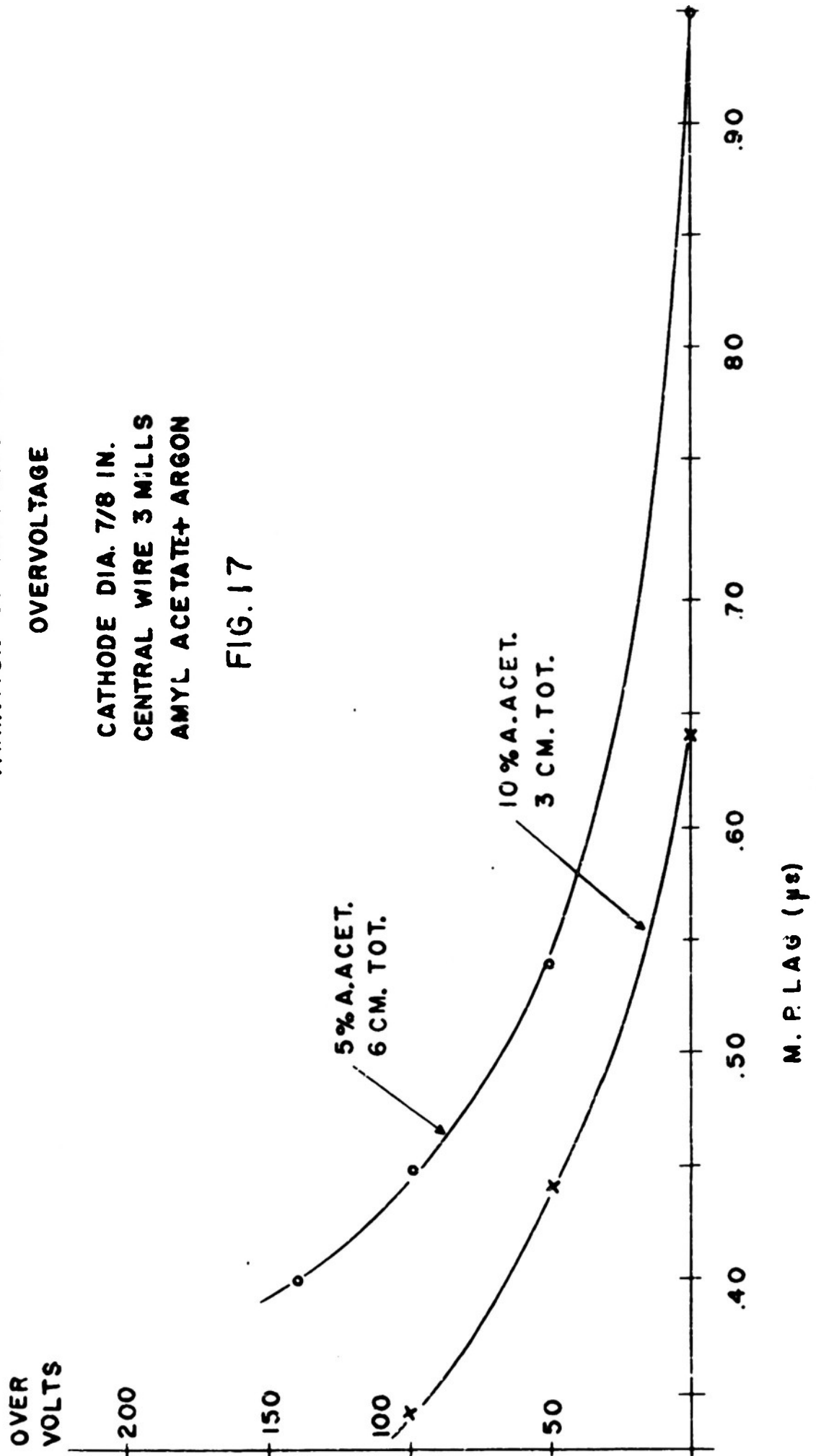

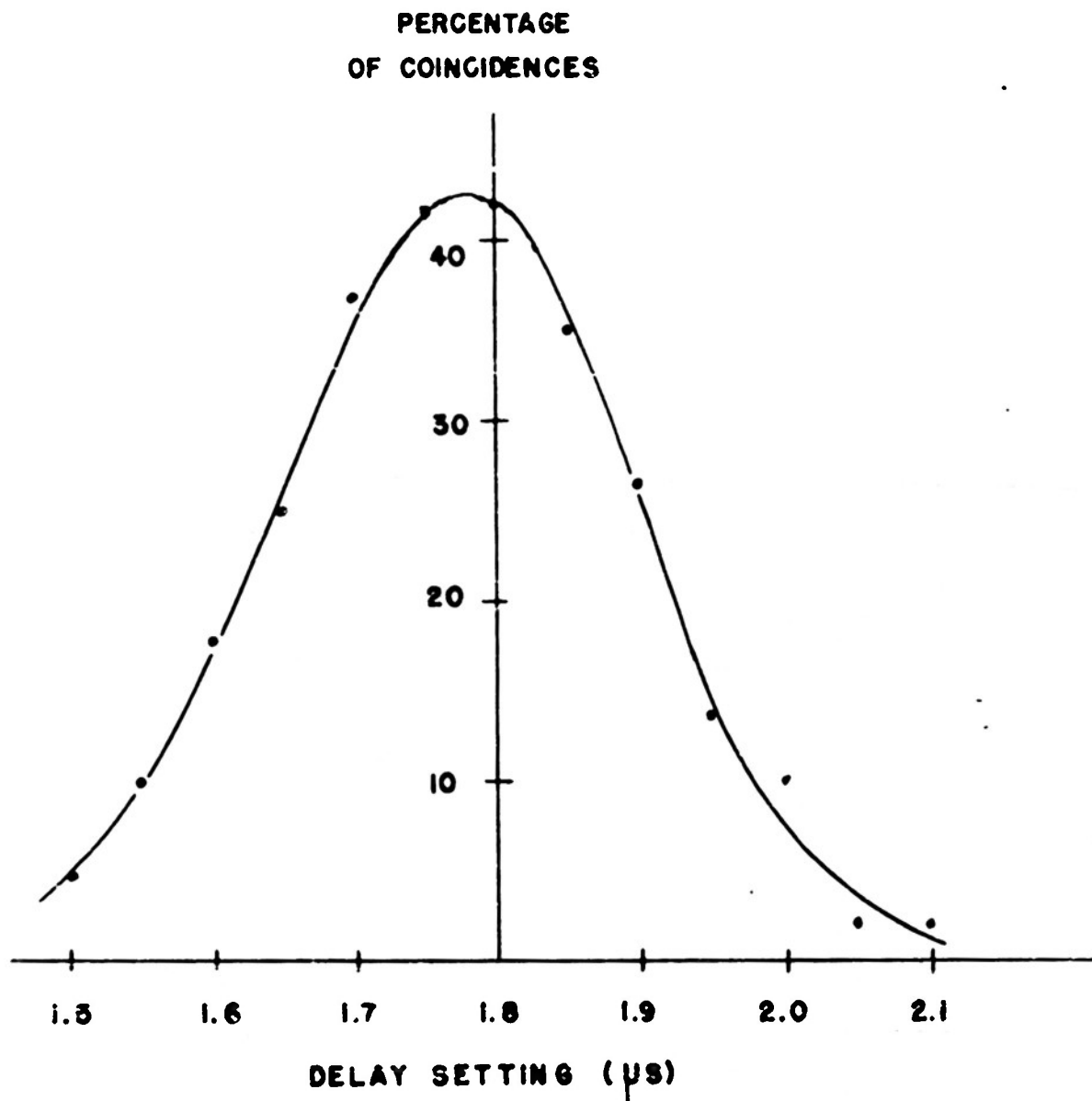

TYPICAL DISTRIBUTION OF COINCIDENCES

CATHODE DIA. 6 CM
CENTRAL WIRE 3 MILLS
10% E. ALCOHOL + 90% ARGON
150V. OVERTOLTS

FIG. 18

DURATION OF LIGHT FROM SPARK

FIG. 19

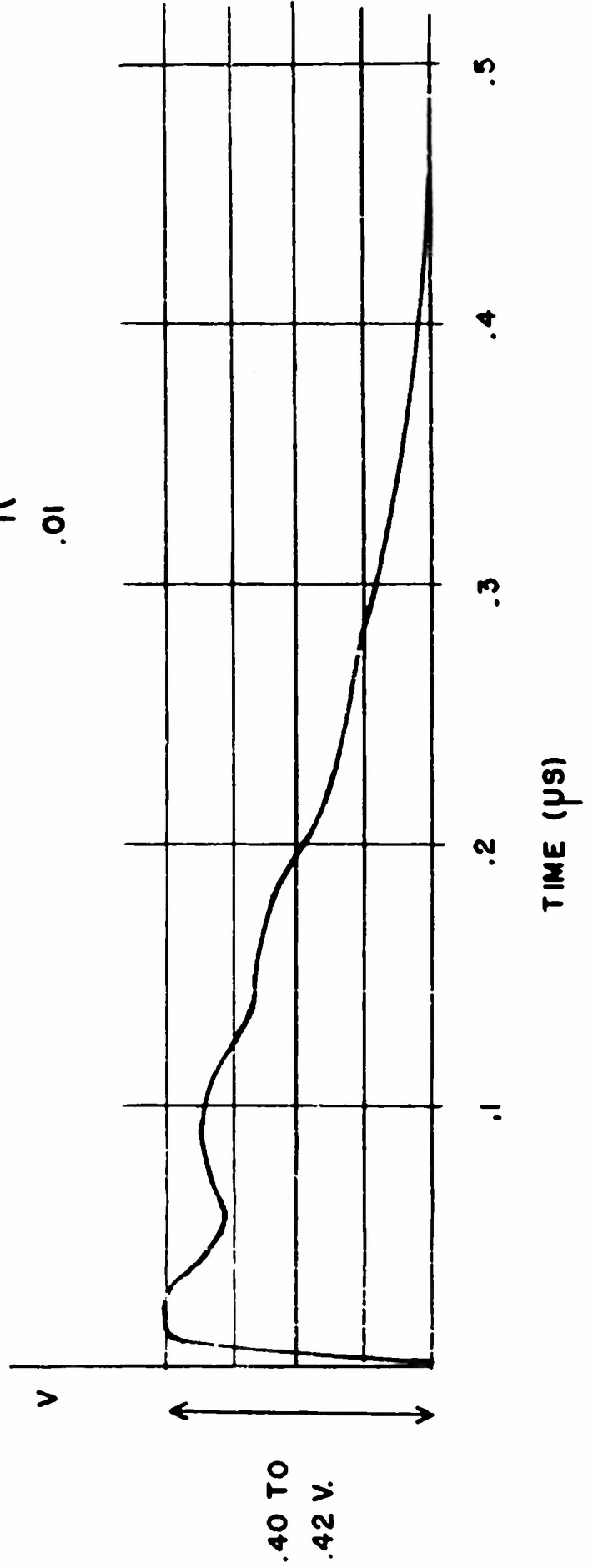
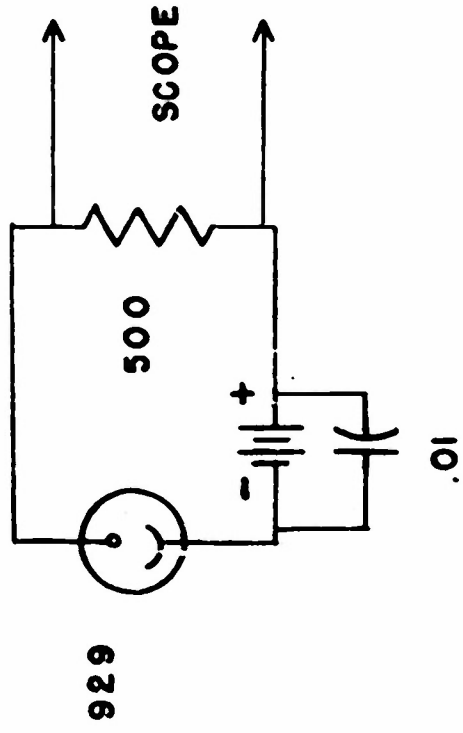

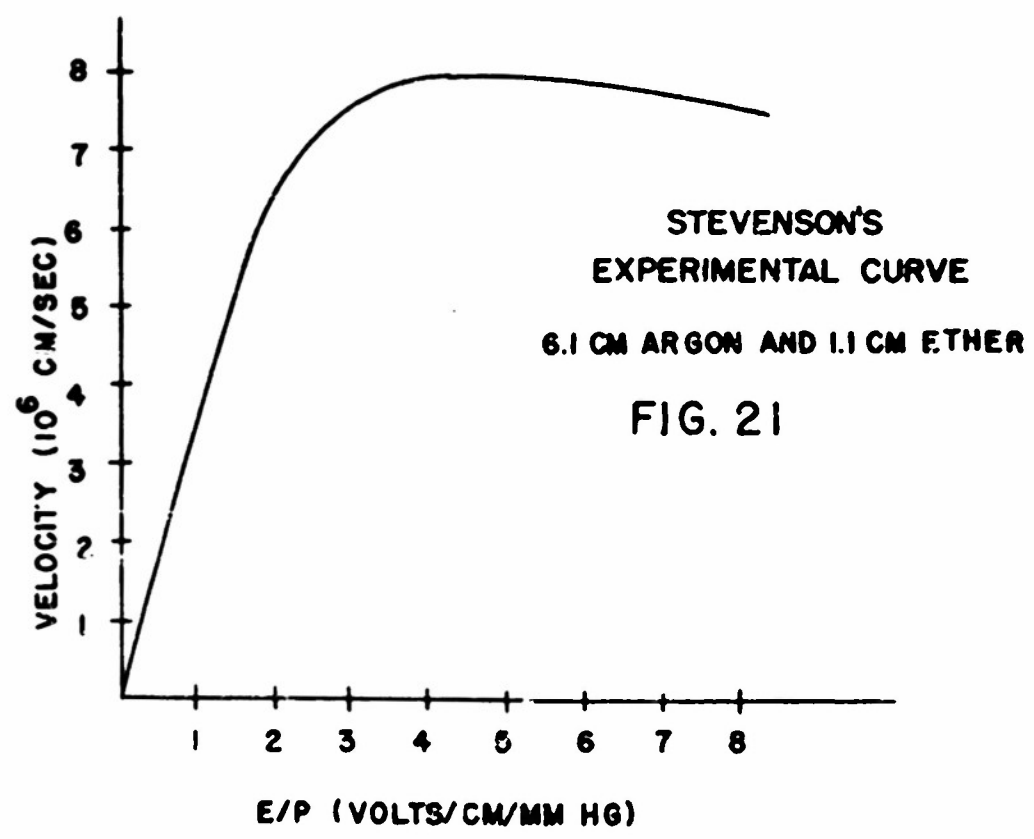
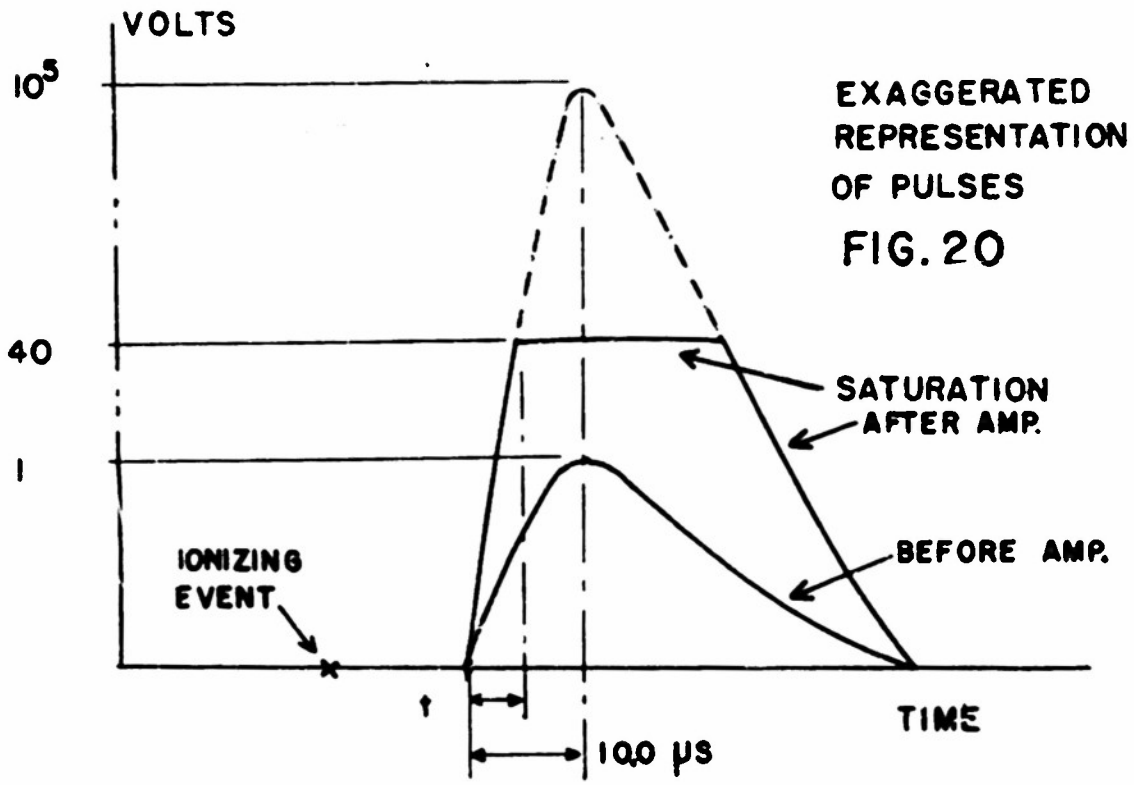
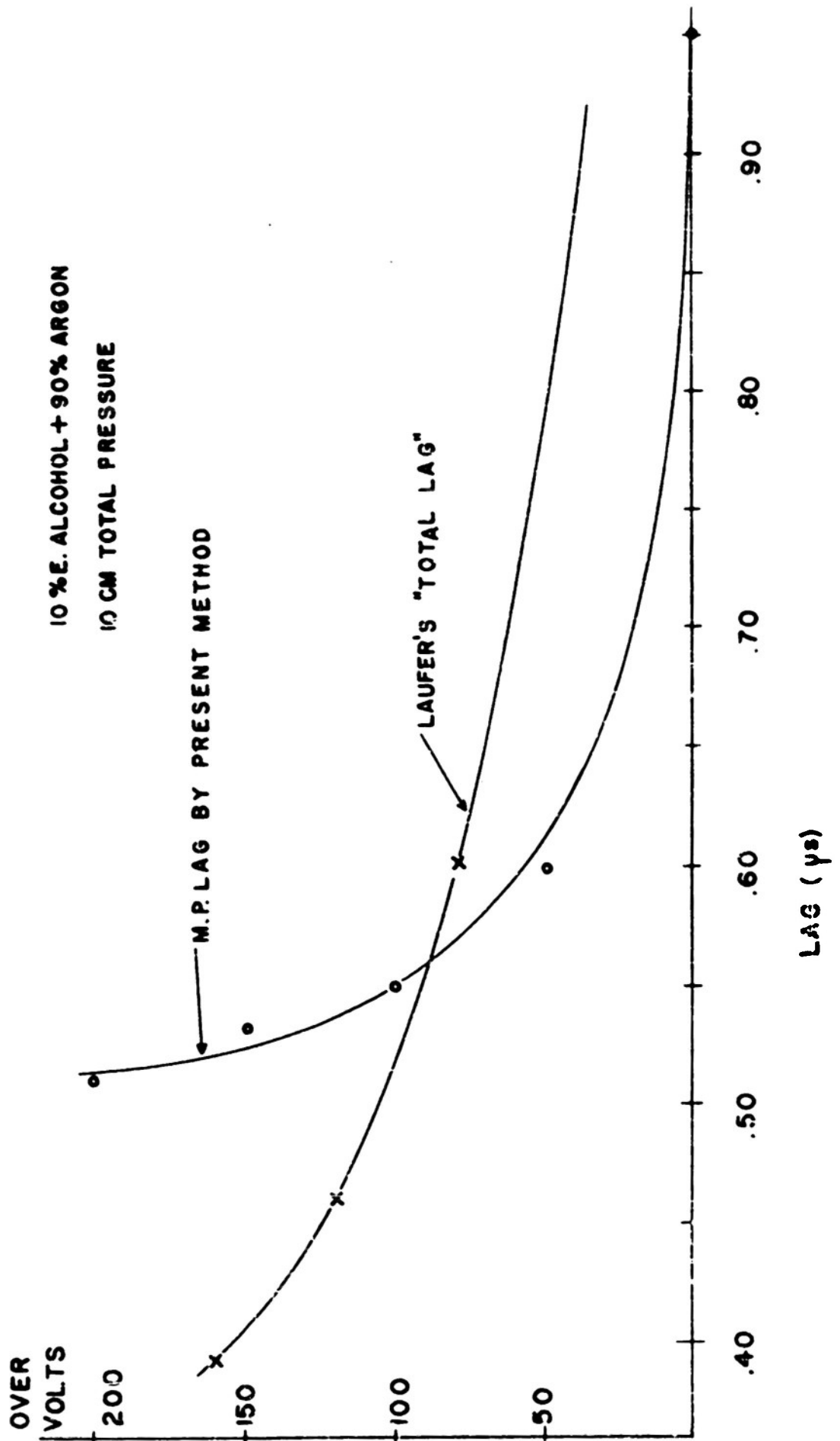

FIG. 22
COMPARISON WITH DATA
OF LAUFER



BIBLIOGRAPHY

I. Apparatus.

1. F. Ayer, Rev. Sci. Inst. 21, 244 (1950).
2. Z. Bay, Rev. Sci. Inst. 22, 397 (1951).
3. J. W. Beams, J.O.S.A. 37, 868 (1947).
4. S. C. Brown, Nucleonics 3, 46 (1948).
5. W. C. Elmore, Nucleonics 2, 4 (1948), 2, 16 (1948).
6. W. C. Elmore and M. Sands, Electronics (McGraw-Hill Book Company, Inc., New York, 1949), p. 120, 160.
7. J. A. Hornbeck, Phys. Rev. 83, 374 (1951).
8. W. H. Jordon and P. R. Bell, Rev. Sci. Inst. 18, 703 (1947).
9. S. W. Kitchen, N.Y.U. Project Report No. 141.01.
10. E. O. Lawrence and J. W. Beams, Phys. Rev. 32, 478 (1928).
11. S. Lormeary, C. R. Acad. Sci. Paris 225, 453 (1947).
12. J. D. Loow and S. M. Naude, Phys. Rev. 76, 571 (1949).
13. A. Lundby, Rev. Sci. Inst. 22, 324 (1951).
14. C. E. Mandeville and M. V. Scherb, Nucleonics 7, 34 (1950).
15. C. G. Montgomery, W. E. Ramsey, D. B. Cowie, and D. D. Montgomery, Phys. Rev. 56, 635 (1939).
16. C. G. Montgomery and D. D. Montgomery, Rev. Sci. Inst. 18, 411 (1947).
17. M. V. Scherb, Phys. Rev. 73, 86 (1948).
18. D. R. Scoll, Indus. Eng. Chem. 39, 517 (1947).
19. B. Smaller and E. Avery, Rev. Sci. Inst. 22, 341 (1951).
20. R. N. Varney, Phys. Rev. 88, 362 (1952).

II. Lag Distributions.

1. J. Agresta, N.Y.U. Project Report No. 141.04.
2. H. Bradt and P. Scherrer, *Helv. Phys. Acta* 16, 251 (1943a), 16 259 (1943b).
3. S. De Binedetti and F. K. McGeowan, *Phys. Rev.* 74, 728 (1948).
4. D. Binder, *Phys. Rev.* 76, 856 (1949).
5. D. F. Bunyan, A. Lundby, and D. Walker, *Proc. Phy. Soc.* 62a, 253 (1948), 62a, 398 (1948).
6. H. den Hartog, F. A. Muller, and N. F. Verster, *Physica* 13, 251 (1947).
7. A. R. Laufer, N.Y.U. Thesis, 1949, *Rev. Sci. Inst.* 21, 244 (1950).
8. A. Lundby, *Forvarets Forskningsinstitutts Arbok 1948-49*, p. 29.
9. L. Madansky and R. W. Fidd, *Rev. Sci. Inst.* 21, 407 (1950).
10. B. D. Nag, S. Sen, and S. Chatterjee, *Nature* 164, 1001 (1949).
11. B. D. Nag, S. Sen, and S. Chatterji, *Ind. J. Phys.* 24, 261 (1950).
12. F. Rasetti, *Phys. Rev.* 60, 198 (1941).
13. B. Rossi and N. Nereson, *Phys. Rev.* 62, 417 (1942).
14. C. W. Sherwin, *Rev. Sci. Inst.* 19, 111 (1948).
15. H. K. Ticho, *Rev. Sci. Inst.* 18, 271 (1947).

III. Electron Mobilities.

1. Allen, *Phys. Rev.* 52, 707 (1937).
2. L. Colli and U. Facchini, *Rev. Sci. Inst.* 23, 39 (1952).
3. L. Colli and M. T. De Leonardis, *J. App. Phys.* 24, 255 (1953).
4. E. M. Conwell, *Phys. Rev.* 86, 1379 (1952).
5. K. K. Darrow, *Electrical Phenomena in Gases* (Williams and Wilkins, Baltimore, 1932).

6. H. den Hartog and F. A. Muller, *Physica* 15, 789 (1949).
7. E. Funfer and H. Neuert, *Z. angew. Phys.* 2, 241 (1950).
8. G. P. Harmwell, *Phys. Rev.* 29, 683 (1927).
9. R. H. Healey and J. W. Reed, *The Behavior of Slow Electrons in Gases* (Amalgamated Wireless, Ltd., Sydney, 1941).
10. J. A. Hornbeck, *Phys. Rev.* 84, 615 (1951).
11. J. A. Hornbeck and G. H. Wannier, *Phys. Rev.* 82, 458 (1951).
12. J. M. Kirshner and D. S. Toffolo, *J. App. Phys.* 23, 594 (1952).
13. S. A. Korff, *Phys. Rev.* 72, 477 (1947).
14. H. Kumagai, K. Shimoda, I. Ogawa, Y. Torikai, and T. Kodama, *J. Phy. Soc. Japan* 4, 39 (1949).
15. C. E. Mandeville and M. V. Scherb, *Phys. Rev.* 73, 90 (1948).
16. P. L. Morton, *Phys. Rev.* 70, 358 (1946).
17. A. Nawaiji and J. de Jong, *Physica* 10, 513 (1943).
18. H. Neuert, *Ann. Phys. Lpz.* 8, 341 (1951).
19. W. C. Porter and W. E. Ramsey, *Rev. Sci. Inst.* 23, 95 (1952).
20. W. E. Ramsey, *Rev. Sci. Inst.* 23, 95 (1952).
21. B. Rossi and H. H. Staub, *Ionization Chambers and Counters* (McGraw-Hill Book Company, Inc., New York, 1949), Chapt. I.
22. R. P. Stern, *Phys. Rev.* 89, 134 (1953).
23. A. Stevenson, *Rev. Sci. Inst.* 23, 94 (1952).
24. P. B. Weisz and W. P. Kern, *Phys. Rev.* 75, 899 (1949).

IV. General.

1. F. Alder, E. Baldinger, P. Huber, and F. Metzger, *Helv. Phy. Acta* 20, 73 (1947).
2. C. Balakishnan and J. D. Craggs, *Proc. Phy. Soc. Lond.* 63a, 358 (1950).

3. S. Chapman and T. G. Cowling, The Mathematical Theory of Non-Uniform Gases (Cambridge University Press, Cambridge, 1939), Chapt. 18.
4. M. Chaudhri and A. G. Fenton, Proc. Phys. Soc. Lond. 60, 183 (1948).
5. D. R. Corson and R. R. Wilson, Rev. Sci. Inst. 19, 207 (1948).
6. J. D. Craggs and A. A. Jaffe, Phys. Rev. 72, 784 (1947).
7. J. D. Craggs, W. Bosley, and A. A. Jaffe, J. Sci. Inst. Phys. Ind. 25, 67 (1948).
8. S. C. Curran and J. D. Craggs, Counting Tubes, Theory and Application (Academic Press, Inc., New York, 1949).
9. L. F. Curtiss, National Bureau of Standards Circular 490, 1950.
10. H. Friedman, Proc. Inst. Rad. Eng. 37, 791 (1949).
11. L. L. Haines, Rev. Sci. Inst. 7, 411 (1936).
12. W. Heitler, Quantum Theory of Radiation (Oxford University Press, Oxford, 1944), p. 218.
13. D. E. Hull, Rev. Sci. Inst. 22, 338 (1951).
14. L. Jannosy, Elect. Eng. (Mar., 1945).
15. A. J. Knowles, C. Balakrishnan, and J. D. Craggs, Phys. Rev. 74, 627 (1948).
16. L. B. Loeb, Fundamental Processes of Electrical Discharge in Gases (John Wiley, New York, 1939).
17. C. G. Montgomery and D. D. Montgomery, Phys. Rev. 57, 1030 (1940).
18. L. J. Rainwater and C. S. Wu, Nucleonics 1, 60 (1947).
19. W. E. Ramsey, Phys. Rev. 57, 1022 (1940).
20. C. V. Robinson and R. E. Peterson, Rev. Sci. Inst. 19, 911 (1948).
21. H. Saltzman and C. G. Montgomery, Rev. Sci. Inst. 21, 548 (1950).
22. C. D. Thomas, Rev. Sci. Inst. 20, 147 (1949).
23. P. B. Weisz, Phys. Rev. 74, 1807 (1948).
24. D. H. Wilkinson, Ionization Chambers and Counters (Cambridge University Press, Cambridge, 1950).