

UNCLASSIFIED

AD NUMBER

AD020254

CLASSIFICATION CHANGES

TO: unclassified

FROM: secret

LIMITATION CHANGES

TO:  
Approved for public release, distribution unlimited

FROM:  
Controlling Organization: British Embassy,  
3100 Massachusetts Avenue, NW, Washington,  
DC 20008.

AUTHORITY

DSTL, AVIA 26/1689, 16 Sep 2008; DSTL,  
AVIA 26/1689, 16 Sep 2008

THIS PAGE IS UNCLASSIFIED

# Armed Services Technical Information Agency

# AD

# 20254

NOTICE: WHEN GOVERNMENT OR OTHER DRAWINGS, SPECIFICATIONS OR OTHER DATA ARE USED FOR ANY PURPOSE OTHER THAN IN CONNECTION WITH A DEFINITELY RELATED GOVERNMENT PROCUREMENT OPERATION, THE U. S. GOVERNMENT THEREBY INCURS NO RESPONSIBILITY, NOR ANY OBLIGATION WHATSOEVER; AND THE FACT THAT THE GOVERNMENT MAY HAVE FORMULATED, FURNISHED, OR IN ANY WAY SUPPLIED THE SAID DRAWINGS, SPECIFICATIONS, OR OTHER DATA IS NOT TO BE REGARDED BY IMPLICATION OR OTHERWISE AS IN ANY MANNER LICENSING THE HOLDER OR ANY OTHER PERSON OR CORPORATION, OR CONVEYING ANY RIGHTS OR PERMISSION TO MANUFACTURE, USE OR SELL ANY PATENTED INVENTION THAT MAY IN ANY WAY BE RELATED THERETO.

Reproduced by  
DOCUMENT SERVICE CENTER  
KNOTT BUILDING, DAYTON, 2, OHIO

# SECRET

The following **ESPIONAGE NOTICE** can be disregarded unless this document is plainly marked **RESTRICTED, CONFIDENTIAL, or SECRET.**

**NOTICE: THIS DOCUMENT CONTAINS INFORMATION AFFECTING THE NATIONAL DEFENSE OF THE UNITED STATES WITHIN THE MEANING OF THE ESPIONAGE LAWS, TITLE 18, U.S.C., SECTIONS 793 and 794. THE TRANSMISSION OR THE REVELATION OF ITS CONTENTS IN ANY MANNER TO AN UNAUTHORIZED PERSON IS PROHIBITED BY LAW.**



CONDITIONS OF RELEASE

THIS INFORMATION IS DISCLOSED ONLY FOR OFFICIAL USE BY THE RECIPIENT GOVERNMENT AND SUCH OF ITS CONTRACTORS, UNDER SEAL OF SECRECY, AS MAY BE ENGAGED ON A DEFENCE PROJECT. DISCLOSURE TO ANY OTHER GOVERNMENT OR RELEASE TO THE PRESS OR IN ANY OTHER WAY WOULD BE A BREACH OF THESE CONDITIONS.

2. THE INFORMATION SHOULD BE SAFEGUARDED UNDER RULES DESIGNED TO GIVE THE SAME STANDARD OF SECURITY AS THAT MAINTAINED BY HER MAJESTY'S GOVERNMENT IN THE UNITED KINGDOM.

M.O.S. Form 666

DS 02548 7/53 TI

THE POLARISATION CHARACTERISTICS OF CERTAIN RADAR ECHOES ON X-BAND

SUMMARY

This note covers the design parameters and performance of a novel type of circularly polarised radar. Any complex echo can be resolved into two circular and two orthogonal plane components, all components being available simultaneously. By manipulation of these components, using a bridge technique, it is possible to differentiate between different types of target and obtain protection from some types of interference. It is concluded that the radar forms a useful tool for the analysis of the polarisation properties of radar echoes, including those from aircraft.

LIST OF CONTENTS

1. Introduction
2. Principles of Operation of the Radar
3. The Effect of Design Parameters on Errors in Measurements
4. Details of Radar Construction
5. Calibration and Operation
6. Practical Results
  - 6.1 Rain Echoes
  - 6.2 Echoes from Window Jamming
  - 6.3 Ground Echoes
  - 6.4 Aircraft Echoes
7. Conclusions and Recommendations
8. Acknowledgement

1. INTRODUCTION

Much useful work has been done upon the echoing properties of aircraft and other targets, chiefly directed towards measurement of their echoing areas; but the effect of polarisation upon the echo has perhaps not received all the attention which it deserves. A useful report by Goldstein<sup>1</sup> surveys the problem in so far as it affects sea echoes and one by Clegg<sup>2</sup> shows clearly the effect of two different polarisations under certain conditions on X band. With more complex targets such as aircraft and ground echoes, the information is confusing and often conflicting. In the spring of 1951 some qualitative measurements were made of aircraft echoes on X band<sup>3</sup> which indicated that the cross polarised component of the echo was substantially less than the component parallel to the transmitter polarisation which was either vertical or horizontal. Further quantitative work by Robinson<sup>4</sup> on Q band showed similar results and he also observed that the difference between the cross-polarised and parallel components was reduced if 45° polarisation was used. These latter measurements have been extended to X band and appear to give results of the same order of magnitude. Previously White<sup>5</sup>, working on L band, and using an equipment in which the polarisation could be rapidly switched from vertical through circular to horizontal, had estimated a loss of the order of 6 dB when using circular compared with the two plane polarisations, and suppression of rain echoes using circular polarisation of the order of 30 dB and sometimes more.

In the summer of 1951 a scheme was suggested<sup>6</sup> extending the well-known properties of circular polarisation as used to reduce echoes from symmetrical targets such as rain, to make an analysis of the polarisation of any desired incoming signal, and in certain cases to discriminate between wanted and unwanted targets.

SECRET

A radar set, built in the winter 1951-52 gave qualitative confirmation to these predictions and it was therefore decided to build a radar capable of making quantitative and repeatable measurements. It is the purpose of this Technical Note to discuss the design of this radar and the results obtained with it.

2. PRINCIPLES OF OPERATION OF THE RADAR

The design principles have already been described<sup>6</sup> so that they will only be outlined here.

Suppose that any conventional transmitter-receiver, generating plane polarised waves, be connected to a waveguide system containing a circularising section, and that it emits a right hand circularly polarised wave (C.P.W.). Any incoming right hand C.P.W. will emerge from the circularising section polarised parallel to the transmitter-receiver (which we will call Channel A) and can be displayed.

Any incoming left hand C.P.W. will emerge from the circularising section polarised perpendicular to the transmitter; in a conventional C.P. radar this signal is normally rejected and lost. There is no reason, however, why it should not be separated from the Channel A signal by a grating or other device, and fed to another receiver which we will call Channel B.

From a study of certain elementary targets, it is clear that the two channels may be expected to behave very differently. For instance, symmetrical targets, including metal or dielectric spheres (e.g. rain), plane sheets or threeface corner reflectors, will return signals orthogonally polarised to the incident radiation, and so will give a signal in Channel B and no signal in Channel A. Twoface corners, known in the U.S.A. as di-planes, will return a signal in which the direction of rotation is twice reversed and so give the same direction of rotation as the radiated signal. They will thus produce a signal in Channel A but none in Channel B.

Plane polarised targets or plane polarised active jammers will produce equal signals in both channels, since any plane polarised signal may be resolved into two equal circular components rotating in opposite directions.

Signals from any complex target, large compared with the wavelength, will in general be elliptically polarised, and if the constituent parts of the targets, which contribute to the echo, are moving relatively to each other, the voltage ellipticity ratio, which corresponds to the relative magnitudes of the A and B signals (see Eq. 1), and the orientation of the major axis of the ellipse, which corresponds to the phase separation of the A and B signals, will be constantly varying. Such targets may be expected to produce signals in the two channels of equal mean magnitude but which vary rapidly and independently.

Full information on the echo is not available unless we take note of the phase separation of the two signals. If the signals are combined before demodulation, there is one particular incoming polarisation which will bring the two channels into phase and analysis shows that the orthogonal polarisation will cause the two signals to cancel. A phase bridge has been produced which accepts signals A and B at intermediate frequency and produces two output signals corresponding to the vertical and horizontal components of any incoming signal.

By making different the gain in the two arms of the bridge, it is possible to select an output corresponding to any desired ellipticity, and so to compensate for non-circularity introduced by slight defects in the waveguide system. This phase bridge, referred to hereinafter as Channel C, would, it was hoped, make the radar virtually independent of frequency change and of manufacturing tolerances so far as Voltage Ellipticity Ratio was concerned.

SECRET

It is worth emphasizing that an equipment of this sort makes no attempt to measure absolutely either signal to noise ratios or the echoing areas of targets. It is in effect a radio frequency bridge which compares two or more simultaneous signals. Such measurements are, of course, fundamentally easier than a number of successive absolute measurements which rely upon the stability of the radar set and the repeatability of the target and the propagation conditions.

A word of warning is also necessary in saying that the results obtained on X band should not rashly be extrapolated to other frequencies where the echoing properties of targets may be different.

3. THE EFFECT OF DESIGN PARAMETERS UPON ERRORS IN MEASUREMENT

3.1 In Section 2 we have assumed that the radar is perfectly designed so that it radiates a perfect C.P.W., i.e., Voltage Ellipticity Ratio = 1. In practice this will not be so and a measure of ellipticity will be introduced.

This ellipticity, which amounts to the generation of a spurious signal of the opposite sense of rotation, may upset the ratio of the two components which we are trying to compare, and in particular will render quite worthless any measurement of the "cancellation" of rain unless the extent of the ellipticity is known and controlled.

It has been shown<sup>6</sup> that an elliptically polarised wave of V.E.R. = k may be resolved into two orthogonal circular components of amplitudes A and B, governed by the relation:-

$$\frac{B}{A} = \frac{1 - k}{1 + k} \quad \dots \text{Eq.1}$$

which is well known as the reflected/transmitted amplitude relationship in a line of V.S.W.R. = k.

This function is plotted on a decibel scale in Fig. 1, and it should be noted that in the practical case the wave passes twice through the system before reaching the receivers. The spurious signal is thus approximately doubled in voltage (when its magnitude is small compared with the desired signal). This accounts for the lateral displacement of the cancellation ratio/Voltage Ellipticity curve by 6 dB. It will be seen that a high order of circularity is needed to obtain good cancellation and in particular a cancellation of 40 dB, claimed by some workers calls for a V.E.R. of 0.99.

3.2 There are four principal ways in which ellipticity may be introduced into the system. They are:-

- 3.2.1 Mismatches at the orifice or elsewhere in the system.
- 3.2.2 Inequality in the two plane components of the C.P.W.
- 3.2.3 Phase separation other than 90°.
- 3.2.4 Imperfect separation of plane components.

3.2.1 Mismatches

Fig. 2 shows the schematic diagram of a waveguide system intended to produce circularly polarised waves. It consists of a transformer section which converts the guide dimensions to a size large enough to support propagation in both planes, a section in which the signal is effectively split into two orthogonal plane polarised components; a circularising section in which one of these components is delayed by 90° with respect to the other, and an orifice section which couples the wave to free space. Discontinuities may arise in any of these sections, but whatever their magnitude and phase they can be resolved into two reflected waves returning into the transformer, one polarised parallel to the original polarisation, the other one perpendicular to it.

SECRET

The parallel polarised component will travel along the waveguide system and will eventually reach the magnetron, where its effect will be entirely conventional. Provided that its magnitude is kept down sufficiently to avoid frequency pulling, little harm will result, and any power reflected off the magnetron will produce only circularly polarised radiation of the original direction of rotation. This will affect the magnitude but not the ellipticity of the radiated signal.

The perpendicular component cannot be propagated beyond the transformer, so it will be reflected in entirety towards the orifice, being converted by the circulariser to circular polarisation of the opposite hand. This is liable to have a serious effect on the V.E.R. to an extent shown in Fig. 1. If we make the reasonable assumption that any discontinuities occurring after the circulariser are equal and coincident for the two planes, virtually all the power reflected will return to the transformer cross polarised and will emerge for a second time. Under these circumstances, the Voltage Standing Wave Ratio at the orifice corresponds exactly to the V.E.R. produced, since each correspond to the same power ratio. To return to our earlier example, a suppression of 40 db on symmetrical targets calls for a match at the orifice, including reflections from any paraboloid which may be used, of 0.99 or better.

Since this is not easy to achieve over a wide frequency range, steps must be taken to eliminate the cross polarised component before it can do any harm. White<sup>5</sup> and others have used lossy material to line those walls of the guide parallel to the initial plane of polarisation, between the transformer and the 45° transition. This material will have little or no effect on the outgoing signal but will effectively absorb most of the cross polarised component. If we suppose that the orifice mismatch is not worse than 0.8 and that the match of the lossy section is the same, we have a 1% power reflection twice repeated and the overall V.E.R. is improved to 0.98. It is possible to improve on these figures.

This arrangement is not open to us in the radar to be described, but comparable arrangements have been made to absorb any cross polarised signal reflected while the T.R. coils are striking (see Para. 4.8).

One further effect of mismatches is worth mentioning, though its effects are of a second order only; and that is the power lost by reflection. A V.S.W.R. of 0.8 corresponds to a power loss of about 1%, so that the outgoing voltage is reduced by 0.5%. This could produce a V.E.R. of 0.995 if the reflection was in one plane only. This is trivial enough, but the effect is still further reduced by the fact that it is customary to make symmetrical those parts of the waveguide system after the circularising section.

### 3.2.2 Inequality in the two plane components of the C.P.W.

It is customary to start with plane polarisation and to resolve it into two components, one 45° to the left and one 45° to the right. Inequality in these components can come either from a differential mismatch of the circulariser to these two plane components or from a departure from 45° of this angle. The first of these errors is virtually the same as that discussed in the last paragraph of 3.2.1 above, where a differential mismatch of 0.8 is shown to produce a minimum V.E.R. of 0.995. The effect of an angle other than 45° can be readily calculated as the V.E.R. follows a simple tangent law. The results, for angles between 40° and 45° are plotted in Fig. 3. To meet our self-appointed specification of V.E.R. = 0.99 we need an angular accuracy of the order of 20 minutes of arc. This is not difficult to achieve and is, of course, independent of frequency.

### 3.2.3 Phase separation other than 90°

When a C.P.W. is compounded from two equal orthogonal plane waves<sup>6</sup> of phase separation  $\delta$ , the V.E.R. =  $k$  is governed by the relation:-

$$\tan \delta = \frac{2k}{1 - k^2} \quad \dots \text{Eq.2}$$

SECRET

This is plotted on Fig. 4. The relationship is nearly linear for values of  $k$  between 0.8 and 1.0 and for a V.E.R. of 0.99 we need a phase separation of  $90^\circ \pm 0.6^\circ$ . This seems likely to be the most critical of the parameters we have so far discussed, because most phase shifting devices are sensitive to frequency. Fortunately for the purposes of this investigation, no very great band width is needed and a simple phase shifter of rectangular guide was thought to be sufficient. The guide dimensions were chosen to be 0.8" x 0.9", as this seemed to be a satisfactory compromise between the tolerances required and a reasonable length. Ignoring mismatches, and choosing a length to produce the requisite phase shift at a frequency of 9375 Mc/s, a calculation was made of differential phase change as a function of frequency. This is plotted in Fig. 5, and shows that a band width of approximately 50 Mc/s should be obtained for a V.E.R. of 0.99. This is adequate for our purpose.

The phase separation of the two components will be affected by tolerances, not only in the phase shifter but in any waveguide part in the system where both components exist. Taking waveguide 0.9" x 0.9" for example, and studying the effect of small variations in the dimensions we obtain the relationship plotted in Fig. 6. We note that with guide of standard tolerances of  $\pm 0.001$ ", there is a possibility of our arbitrary tolerance of  $0.6^\circ$  phase being produced in a length of guide of  $1\frac{1}{2}$ ". It is clear that the circularising section and any components subsequent to it will have to be manufactured to very close tolerances. If, for any reason, this does not prove practicable, there is a case for a small adjustable phase shifter covering a range of say  $\pm 2^\circ$ . If the orifice was made circular, in order to achieve a symmetrical primary diagram, this extra phase shifter might take the form of a squeeze section extending over one inch near the mouth. The extent of the squeeze in this case would not need to exceed  $\pm 0.005$ ", and if the orifice was elliptical to this extent, the effect on the radiation pattern would be quite inappreciable.

### 3.2.4 Imperfect separation of plane components

When the incoming signals have passed through the circularising section and exist in square guide as two orthogonal plane polarised components, they still need to be separated. The device used is discussed in Section 4 and makes use of the properties of a grating. Thereafter complete separation can be effected by reverting to standard waveguide which can propagate in only one plane. If, however, the grating is capable of producing a cross polarised component, this will continue to be treated by the system as would any authentic signal and cannot thereafter be removed.

Suppose we imagine one element of the grating to be lying at a small angle  $\theta$  with the direction of the E vector of the incident polarisation. The coupling with the E vector will therefore be a function of  $\cos \theta$ . The element can now be regarded as radiating in its own plane and will therefore produce a cross polarised component  $f(\cos \theta \cdot \sin \theta)$ . As  $\cos \theta \approx 1$ , the cross polarised component may be taken as  $f(\sin \theta)$  and, to take a practical case, the component is unlikely to exceed a level of -41 db if the angle of the grating elements does not depart by more than  $0.5^\circ$  from the incident plane of polarisation.

In fact, the situation is likely to be better than this because the re-radiated power will travel outwards from the grating in both directions, only half of it entering the receiver in Channel A. A difference of  $0.5^\circ$  between the orientation of the guide and of the grating may therefore produce a spurious signal of level -44 db. Results will be similar if the polarisation is allowed to rotate relative to the guide or vice versa. Experiments were carried out which confirmed that the polarisation makes little attempt to follow a gentle twist in square guide, so that the original axes, dictated by the first standard-to-square waveguide transformer must be rigidly enforced if the best results are to be obtained. There is reason to believe that for small random variations of each elements of the grating, the cross polarised component will be very small.

SECRET

3.3.1 Addition of errors up to waveguide orifice

Suppose we assume that each of the first three causes of error discussed in Section 3.2 is capable independently of producing a V.E.R. of 0.99. A resultant V.E.R. of 0.97 might be produced if the orientations of each ellipse were identical but this cannot be so since the orientations are governed by the cause of error. The error due to mismatches can produce ellipticity with the major axis lying at any angle, since this angle is a function only of the phase of the two interfering signals. When the error is due to inequality in the two components, the major axis of the ellipse will be at  $\pm 45^\circ$  with respect to the initial polarisation, but when it is due to a phase error in the circulariser it will be parallel or perpendicular to the initial polarisation. The two latter errors therefore cannot cancel nor can they completely add. As a close approximation therefore we may take the total probable spurious voltage to be the square root of the sum of the squares of the individual voltages, leading to a probable V.E.R. of 0.983 and a corresponding suppression of perfectly symmetrical targets of 36 db.

3.3.2 Effect of aerial

We have discussed so far only the effect of errors in the waveguide system. If a perfectly symmetrical orifice is used as a primary feed for a perfectly symmetrical secondary radiator, no ellipticity should be produced in the centre of the beam. This, of course, is not a practical possibility and the effect of errors of manufacture and of design imposed by practical requirements are difficult to estimate and extremely tedious to compute. To these must be added the operational difficulty of ensuring that the target is in the correct part of the beam during any measurements and the effect of multipath transmissions and reflections on the polarisation.

It was decided therefore to concentrate on a good performance up to and including the primary source, and then to measure the V.E.R. in the centre of the secondary beam and the polar diagram in both planes. It is not possible to make a very close estimate of the ellipticity from a study of the polar diagrams, particularly at points where the slope is steep. The ellipticity was checked directly by means of a plane polarised source (actually an echo box) and by noting the fluctuations in the two outputs as the C.P. aerial was moved in azimuth and elevation. Then, knowing the operational conditions of each experiment, an estimate could be reached of the limitations of the equipment under those particular conditions.

It should be pointed out that the degree of cancellation discussed in the last section is that possible with a single receiver only and that it was hoped that the high degree of cancellation using two receivers combined in Channel C would be obtained for any value of V.E.R. of 0.7 or more (see Section 4.9).

4. DETAILS OF RADAR CONSTRUCTION

4.1 Transmitter

The radar transmitter was quite conventional, producing a power of 40 kW on a radio frequency of about 9375 Mc/s. The modulator produced approximately 1000 pulses per second each of 1 microsecond duration. Aerial aperture was 36".

4.2 Plane Resolver

Fig. 7 shows a photograph and Fig. 8 a diagram of the plane resolver which incorporates a quarter wave stop transformer converting to a waveguide size of 0.9" x 0.9" (i.d.) and which serves to separate the two orthogonal components of the incoming signal. The transmitter signal is unaffected by the grating and the slot and passes to the  $45^\circ$  transition section.

#### 4.3 45° Transition

(Figs. 9 and 10) The purpose of this is to cause the electric vector to lie along the waveguide diagonal with a minimum discontinuity. If the electric vector lies along the diagonal, then the elements of the circularising section must be perpendicular or parallel to the walls of the circularising guide, which eases calculation. There seems no other great advantage in using this system compared with one using a perpendicular electric vector and a diagonal phase shifter.

#### 4.4 Circularising Section

As only a narrow frequency band had to be covered, the phase shifting section could be quite simple. It was decided to use rectangular guide of dimensions 0.9" x 0.8" to produce the differential phase velocity between the two components. It was of all-metal construction and so close tolerances could be maintained by electroforming or other techniques. These tolerances were found necessary owing to a tendency for the component to generate a high order E mode of propagation. This showed itself as a number of high Q resonances in the curve of V.S.W.R. The coupling to the E mode was severe with the first model of the phase shifter because the design was asymmetrical (Fig. 11). With a symmetrical design (Fig. 12) results were much improved and as the residual resonances were very small in magnitude it was decided to ignore them. A square-to-circular transition completed the waveguide run.

#### 4.5 Aerial Feed

The feed to the paraboloid presented something of a problem, owing to the difficulty of taking the signals round a bend in square guide and still maintaining circularity. In the first model, a half paraboloid was used and the waveguide components offset in front of it. A reasonable circularity was maintained on the axis of the beam but rather serious departures from circularity occurred in the skirts. Therefore recourse was had to a symmetrical paraboloid and the square waveguide taken to it by two bends, mutually at right angles (see Fig. 13). It was hoped that the relative phase shift between the two orthogonal vectors introduced by one bend would be corrected in the next. To a first order, at any rate, these hopes have been justified. That part of the waveguide run in the field of the aerial was protected with radar absorbent material, and in the interests of symmetry the support right across the aperture was similarly protected.

#### 4.6 Plane Polarised Feed

In certain cases it is of interest to radiate a plane polarised signal and compare the parallel and perpendicular components of the echoes. A convenient way of doing this is to add an extra circularising section at the orifice. The design adopted was that reported by Simmons<sup>7</sup> and worked satisfactorily. The component was a good push fit into the waveguide and the plane of polarisation of the radiated wave could be continuously adjusted by rotating the extra circulariser. The "plane" wave so produced was, in fact, elliptically polarised with a major-to-minor axis ratio 28 db. This was adequate for the purpose intended, namely measurements on aircraft.

#### 4.7 Channel A Receiver

The Channel A receiver, which is coupled into the waveguide run between the transmitter and the plane resolver, is conventional except that the valve pins are soldered into circuit in the interests of gain stability. This applies also to the Channel B receiver. The Channel A receiver accepts signals of like polarisation to that radiated and in the case of circularly polarised radiation these will hereinafter be referred to as anti-symmetrical signals.

SECRET

4.8 Channel B Receiver

The Channel B receiver accepts signals orthogonally polarised to those radiated and in the case of circularly polarised radiation these will be referred to as symmetrical signals. This receiver is fed from the branch of the plane resolver which is illustrated in Fig. 8. Symmetrical signals will be polarised perpendicular to the initial plane of polarisation and therefore parallel to the elements of the grating. This follows the contours of an H plane corner and the resonant slot acts as a window across the waveguide. The branch is coupled to the Channel B receiver by a system of TR cells similar to that used in a normal transmitter except that the cells are arranged to connect the branch to a dummy load when the transmitter operates. In order to achieve this, the usual ATR cell is replaced by a TR cell, as the only power available to strike them is that reflected from the various mismatches in the system. We have the rather unusual phenomenon of a prohibited range of mismatches in the feed. For values of mismatch between 0.7 and 0.9, there is enough power in the branch to strike both TR cells and the resultant reflected signal contributing to ellipticity produces only a second order error. For values of mismatch greater than 0.99, the reflection from the branch can be ignored, but the achievement of this figure scarcely justifies the trouble. For values of mismatch between 0.9 and 0.99 there is a possibility that only one TR cell in the branch will strike, producing a serious mismatch. Under these circumstances the ellipticity will be largely determined by the system mismatch and so may fall to 0.9. Steps have therefore to be taken to see that the mismatch is not better than 0.9, and, as may be imagined, this is not difficult. Higher transmitter powers and other types of connection will no doubt alter these figures.

4.9 Phase Bridge and Channel C

Mixing of the two signals before phase is lost may be carried out either at radio or intermediate frequency. The advantages of doing it at radio frequency lies in the improved signal to noise ratio, since noise from only one mixer is involved. The advantages of I.F. mixing are increased flexibility, a possibility of a number of simultaneous outputs and non-interference with the normal operation of Channels A and B. For a measuring equipment, the increased noise level of up to 3 db was no handicap, so this latter system of mixing was adopted.

The principles of operation are shown in Fig. 14 and are quite straightforward. Signals from the two head amplifiers A and B are fed to two buffer valves ( $V_1$ ,  $V_2$ ) with independently variable gain. The anodes of each of these valves are coupled to tuned circuits L1 and L2. The two circuits are identical except that in one case one of the coupling windings is reversed in phase. It is clear that if the A and B signals are in phase, in one of the output coils the signals will add, in the other they will cancel. If the phase of A or B is altered by  $180^\circ$  then the two outputs will be reversed. By means of a phase shifter in the local oscillator circuit of one channel, the relative phase of A and B can be adjusted to some suitable value, and as normally set, the bridge outputs correspond to the vertical and horizontal components of any complex echo. These two signals may be referred to collectively as Channel C because they take note of the orientation of incoming polarisation. The magnitudes of Channels A and B, however, are governed by the degree of ellipticity, but not by the orientation of the ellipse. By making gains of the two arms of the bridge unequal, and by suitable adjustment of the phase shifter, Channel C may be adjusted to select or reject any chosen elliptical component of the echo. The chief value of this facility is to eliminate the spurious signal from a perfectly symmetrical target introduced by departure from circularity in the radar (see Sect. 3). This signal in Channel A can be effectively balanced out by feeding in some Channel B signal out of phase. Under these conditions, the gain of  $V_1$  in the phase bridge is at maximum and the gain of  $V_2$  is very low. This of course, will only deal with constant ellipticity such as that produced by the radar; varying ellipticity introduced by the target will be quite unaffected. An alternative way of looking at this operation is to regard it as cancellation obtained by using two orthogonal elliptical polarisations, one for transmission and one for reception.

SECRET

The two Channel C signals coming from the bridge were fed to two I.F. amplifiers with detectors.

4.10 Algebra Unit and Display

A video frequency amplifier unit was constructed to which could be fed two input signals, A and B for example. The unit produced four output signals corresponding to A, B, A - B and m A + n B where m and n could be adjusted to any value between + 1 and - 1.

These four output signals together with one of the Channel C signals as a cross-check, were displayed as Y deflections on five cathode ray tubes (Fig. 15) which could be photographed on 16 mm. film at 16 frames per second. Time base ranges were 5, 10, 20 and 40 miles.

As we have shown in Sect. 2, A and B correspond to the anti-symmetrical and symmetrical components respectively of the echo. The A - B display has a number of interesting features. It is very insensitive to plane polarised signals, since such signals by definition produce equal A and B amplitudes. Deflection up or down would shew the tendency towards A or B in the target; and the rapid beating between A and B which was expected from a moving target offered some possibility of differentiating between man-made structures and rural terrain echoes where wind movement of the trees and leaves might be expected to have an effect.

4.11 When the mA and nB signal was adjusted so that m = n = 1, it was hoped that some of the power lost by splitting the aircraft echo into two nearly equal parts would be regained. The reasoning is as follows:-

<u>Type of Radar</u>	<u>Remarks</u>	<u>Expected Loss</u>
Ideal Plane Polarised Radar	All energy returned from target accepted by receiver	0 db
Practical Plane Polarised Radar (X band experiments Ref. 3)	- 1/2 db lost in cross polarised component	-1/2 db
Circularly Polarised Radar (Power is split equally between channels A and B)	- Channel A	-3 db
	- Channel B	-3 db

The results of post detector addition of the two signals has been summarised by P.M. Woodward.

$$\frac{\text{Signal Power}}{\text{Noise Power}} \text{ at Input} = \frac{\frac{1}{2} P}{N} \quad \dots \text{ Eq.3}$$

$$\frac{\text{Signal Amplitude}}{\text{RMS Noise}} \text{ at Input} = \sqrt{\frac{\frac{1}{2} P}{N}} \quad \dots \text{ Eq.4}$$

$$\frac{\text{Signal Amplitude}}{\text{RMS Noise}} \text{ after detection} = \begin{cases} \frac{\frac{1}{2} P}{N} & P \ll N \quad \dots \text{ Eq.5} \\ \sqrt{\frac{\frac{1}{2} P}{N}} & P \gg N \quad \dots \text{ Eq.6} \end{cases}$$

(Ref. 8)

Addition after detection increases the above values by a factor of  $\sqrt{2}$  because the signal adds coherently.

SECRET

We have therefore:-

$$\frac{\text{Signal amplitude}}{\text{RMS Noise}} = \begin{cases} \frac{P\sqrt{2}}{N} & P \ll N & \dots \text{Eq.7} \\ \sqrt{P/N} & P \gg N & \dots \text{Eq.8} \end{cases}$$

The Power Loss in A + B is therefore:-

$1\frac{1}{2}$  db when  $P \ll N$

0 db when  $P \gg N$

When  $P \sim N$ , some intermediate figure may be expected to obtain, say 1 db.

These figures refer to the ideal plane polarised radar and should be improved by  $\frac{1}{2}$  db when compared with the practical plane polarised radar, giving a nett value of  $\frac{1}{2}$  db loss on A + B, which display can be used for maximum range when there is no rain or other interference. We may also expect the proportional fluctuations in amplitude to be reduced by the addition of two independently fluctuating signals. This applies particularly to signals at or near zero.

4.12 Similar results can be obtained by feeding to the Algebra Unit signals V and H corresponding to the vertical and horizontal components respectively of the echo when illuminated with a C.P.W. Here the V-H display is likely to be the most interesting, inspection immediately showing a target which has an echoing area predominantly vertical or horizontal. Adjustment of gain in the two channels till the signal is balanced, gives a measure of the difference. The V-H channel, incidentally, eliminates both symmetrical and anti-symmetrical echoes.

## 5. CALIBRATION AND OPERATION

The following measurements were carried out on the equipment, in order to test its capabilities.

- 5.1 Measurement of aerial polar diagrams
- 5.2 Measurement of degree of circularity of radiated wave on beam axis
- 5.3 Measurement of circularity on beam axis, using aerial as receiver
- 5.4 Setting up and monitoring
- 5.5 Check on circularity at other points on the polar diagram
- 5.6 Measurement of V.S.W.R. of the waveguide system
- 5.7 Measurement of degree of cancellation obtainable on plane polarised test signal using phase bridge

### 5.1 Polar Diagrams

Fig. 16 shows the aerial polar diagram. The azimuth diagram agrees very closely with that expected from the primary pattern, but the elevation diagram has more and higher side lobes, due probably to the support to the feed. They are of little significance for our purpose, as the main lobe is very similar to that of Fig. 16.

SECRET

5.2 Circularity of Aerial used as Transmitter

This was measured directly using a detector and meter. By a suitable choice of sites, one can eliminate errors due to multiple path transmission, and the beam width at the point of reception is sufficiently broad to accommodate some lateral movement of the receiving aerial if the spatial separation (about 110 yds) is large enough. The detector operates under square law conditions and thus emphasises departures from circularity. The meter could be read to 2% so that measurements of circularity could be made up to within  $\pm 0.01$ , for values above 0.9. For lower values, the meter calibration is of significance and accuracy is somewhat reduced.

The results obtained are shown in Fig. 17 and are quite satisfactory.

5.3 Circularity of Aerial used as Receiver

Matching conditions are quite different during reception from those obtaining during transmission because of the T.R. coil arrangements. The reciprocity theorem does not therefore hold and the circularity must also be measured under receiving conditions. The effective circularity may be measured by picking up a perfect circularly polarised wave and by noting the magnitude of the orthogonal component generated in the aerial. The relative magnitude of the A and B signals gives the effective circularity directly in accordance with Fig. 1. A more convenient, if less elegant, way is to pick up a plane polarised signal and note the relative magnitude of the two orthogonal circular components as the initial plane of the polarisation is slowly rotated. This method was in fact used and produced the results shown in Fig. 18. The exact method adopted served also to monitor the stability of the equipment during operation and as a quick means of setting it up. The test signal was radiated from a slot in the end of a waveguide located at the apex of the mirror, and the waveguide could be rotated about its own axis. The gain of the two channels was adjusted until the signals were equal (i.e.,  $A - B = 0$ ). Thereafter the plane of polarisation of the test signal was rotated and the orientation plotted against the differential gain necessary to keep  $A - B = 0$ . The effective circularity is therefore of the order of 0.95 during reception. In these measurements it was verified that there were no interference effects between the radiating slot and the receiving aperture. Of course the measurement applies only to the primary radiator, but the almost complete symmetry of the mirror system probably justifies an assumption that cross polarisation due to the mirror falls to zero at the centre of the beam. There may be some slight asymmetry due to obstruction of the beam by the waveguide, but this was minimised by shielding the waveguide with radar absorbent material. A "hole" in the amplitude distribution will have much less effect than reflected waves, which will be incorrectly phased, and any resulting asymmetry is too small to have significant effect on the measurements.

5.4 Setting up and Monitoring

It is clear that the test pulse can be radiated throughout any operation and provides confirmation of the stability of the equipment. Departure from balance in the appropriate channel immediately renders the results suspect.

The setting up procedure is very straightforward. When radiating circular polarisation and comparing the symmetrical and anti-symmetrical components, the gain of the two receivers is adjusted until the A-B display has zero deflection. Thereafter the polarisation of the test pulse is rotated to confirm that the balance on the A-B display is maintained to within  $\pm 0.5$  db.

When radiating circular polarisation and comparing two plane components in a Channel C display, the procedure is scarcely longer. The test pulse is adjusted to vertical polarisation (say) and the phase shifter and gain of the phase bridge set to give zero deflection on the H display. The test pulse is rotated to horizontal and it is confirmed that there is no signal on the V display. The test pulse is now turned to  $45^\circ$  and the gain of the two receivers is set to a suitable level and so that  $V - H = \text{zero}$ .

SECRET

A similar adjustment takes place when transmitting plane polarisation and comparing the parallel and perpendicular components of the echo. The only difference is that the use of the phase shifter is replaced by physical rotation of the decircularising section used in the orifice for this type of measurements (see Section 4.6).

5.5 Check on Circularity at Other Points on the Polar Diagram

An echo box technique was used for this measurement as the deduction of V.E.R. from polar diagrams is unlikely to lead to accurate results owing to the steepness of the slope. An error in azimuth of 1/10 degree can produce an error of 0.5 db in level of polar diagram. If this error is oppositely phased in the two diagrams to be compared, perfect circularity can appear as a V.E.R. of 0.9, and vice versa. In addition, the polar diagrams will in general be only in two planes and using two polarisations unless a lot of work is to be involved, and the effect of ground reflections may not be the same during the polar diagram tests as during operation.

A plane polarised aerial connected to an echo box was placed in the beam of the transmitter. The A and B signals returned from this target were equalised at some chosen range, and when the target was on the centre of the beam. Thereafter the transmitting aerial was scanned and the resultant unbalance was noted. As in the previous section, an unbalance of 1 db is equivalent to a V.E.R. of 0.95. This is the difference from that at the centre of the beam. No account is taken of the axis of the ellipse, unless a V - H display is also used. In view of the magnitude involved, there seemed little purpose in this.

The results are shown in Fig. 19.

5.6 V.S.W.R. of Waveguide Components

A number of new waveguide components have had to be developed, but their design was on the whole straightforward; overall results are shown in Fig. 20. Great emphasis was placed on symmetry and so far as was possible all the components were made symmetrical. There were exceptions, of course, two of which have already been mentioned. They were the circularising phase shifter and the aerial feed. In the first case the reduction in guide dimensions from 0.9" x 0.9" to 0.9" x 0.8" was achieved by bringing in both guide walls by 0.05" and each end of each section was matched with a quarter wave step. There are still some traces of resonances believed to be due to the generation of a high order E mode, but they are comparatively harmless. It is believed that they would disappear entirely if tighter manufacturing tolerances were achieved by electroforming or other means.

The same type of resonance appears in the plot of the standing wave ratio of the bends. Preliminary calculations indicated that the radius of the bend in square guide would have to be extremely large, if the amplitude of the signal propagated by the spurious mode was to be kept acceptably low. The cut-off wavelength of the spurious mode was expected to be equal to  $\lambda\sqrt{2}$  where  $\lambda$  is the width of the waveguide and it was suggested that the dimensions of the guide be reduced to 0.85" x 0.85" over the bend. Two bands were therefore made, each two wavelengths long. The spurious resonances were much reduced in amplitude and the overall results were acceptable for the comparatively narrow frequency band required ( $9375 \pm 25$  Mc/s). However, the problem is not yet solved for wide band operation and a basic investigation into methods of dealing with circularly polarised waves would be worthwhile.

The only part of the system, apart from the bends in square guide, which is sensitive to frequency, is the resonant slot in the cross-polarised branch of the plane resolver. Once again, the band width is ample from the point of view of this particular equipment, as the match has to be no better than 0.8 (1% power reflection). This figure, in conjunction with a straight through

SECRET

match (during transmission) of 0.8 is sufficient to keep the twice reflected power to a value of  $1\% \times 1\% = .01\%$ . This cannot produce an ellipticity worse than 0.98. Similarly, the figure of 0.8 in the receiver implies a loss of received power of 0.1 db which is of trivial importance for our purpose. As mentioned in the previous section, some work on the broad banding of this type of component would be profitable.

The other waveguide components were in general symmetrical and presented little problem. The orifice sections were something of a compromise, as a small orifice is needed to produce a broad primary pattern, and a large orifice presents a better match. Once it was found that the matched arm of the plane resolver was working satisfactorily, the V.S.W.R. of the system was not critical and a small orifice was chosen.

A photograph of some assorted waveguide components is shown in Fig. 21.

5.7 Degree of Cancellation obtainable on Plane Polarised Test Signal using Phase Bridge

This was measured directly by noting the differential gain necessary to equalise the parallel and perpendicular components picked up from the test slot. By very careful setting up, a figure of 40 db was obtained, the limits being set by the spectrum of the test pulse and the fact that the I.F. responses of the head amplifiers and bridge circuits were not identical at a level of less than 1% voltage. When the plane of polarisation of the test signal was rotated, the balance on the other polarisation was rather better than 30 db. This figure is taken therefore as the minimum cancellation obtained. It is worth noting that the best protection from circularly polarised unwanted signals is better than this figures, by an amount depending on the waveguide system, which itself affords considerable protection. This improvement is of the order of 20 db if we assume a circularity of 0.9, so we may conservatively assume that cancellation measurements on symmetrical targets are valid up to a value of  $30 + 20 = 50$  db provided that the target is small compared with the beam width. This is not so in the case of rain, and the effect is discussed in Section 6.1

6. PRACTICAL RESULTS

A useful amount of information is available from a device of this sort by simple inspection and adjustment. With some sorts of target there is little need to go further, but with others the useful information only appears as a result of mathematical analysis. This information will no doubt be the subject of a further communication if results warrant it. In the meantime certain results are sufficiently interesting and unambiguous to be recorded here.

6.1 Rain Echoes

As mentioned in the previous section, the following figures were obtained on the performance of the equipment.

Outgoing circularity 0.99  
Receiving circularity 0.95

6.1.1 The latter is likely to be the limiting factor, and produces a theoretical cancellation on perfectly spherical rain of about 32 db. In fact the rain cloud is a diffuse target, often larger than the beam diameter and the ellipticity of the radiated wave will vary over the beam. This ellipticity amounts to the addition of an orthogonal circular component, of amplitude zero in the centre of the beam and increasing towards the skirts. The phase is such that the axes of the ellipse are symmetrical with respect to the centre of the beam. This component, superimposed on an already elliptically polarised wave will improve the circularity in one direction moving from the centre and cause it to degenerate in the other direction. As the effect on the echo will be reduced by the lowered response on the beam

SECRET

skirts, it will have only a second order effect on the cancellation obtainable, which can still be of the order of 30 db.

6.1.2 This varying ellipticity will also reduce the degree of cancellation obtainable in Channel C, even if the cancellation of a point target in the centre of the beam is 50 db or more. Rain in the outlying parts of the beam will return relatively more power into Channel A than will rain in the centre, to an extent shown in Fig. 19. At the -10 db point, for example, the V.E.R. averages 0.96, corresponding to a cancellation of 28 db. The actual signal return will, of course, be down by 20 db, so the spurious signal from a unit volume of rain in the skirt will make a relatively small contribution to the total spurious power.

Integrating the wanted and unwanted power over the solid angle involved reduces the cancellation obtainable, but still leaves a possibility of the order of 40 db. The position would probably be somewhat worse with an aerial producing an asymmetrical beam.

6.1.3 The extent of the cancellation achieved in Channel A alone is measured by setting up the system to display A, A - B, and B, with gain equality shown by the test signal. A variable R.F. attenuator in the Channel B arm is then adjusted to make the vestigial rain signal in the A - B display symmetrical about the base line (i.e., A = B). The attenuator reading is then directly equivalent to the degree of cancellation. Setting accuracy is estimated at  $\pm 1$  db, and, with small errors in gain adjustment etc. producing a further  $\pm 1$  db, the total RMS error is thought to lie within  $\pm 1.5$  db. The very rapid beat rate of the rain echoes assists this type of measurement.

6.1.4 The improvement which Channel C provides over Channel A can be achieved similarly by displaying A - C, and adjusting the Channel A receiver gain to make the rain signals symmetrical with respect to the zero line. This measurement is not as accurate as that of the first order cancellation as the receiver noise is attenuated together with the "wanted" signal, but, if care is taken, the errors are not serious. The principal difficulty is to find any rain giving a sufficiently intense echo to be 40 db or more above the level of the receiver noise and sufficiently spherical to permit cancellation of this order. A higher transmitter power and increased aerial gain would help in this respect.

#### 6.1.5 Rain measurements

It is difficult to generalise on the results because they vary considerably from time to time and even for different rain clouds seen at the same time. The following results are considered sufficiently reliable to be worth quoting.

Bright band: The bright band is the name given to the enhanced echo from that part of the cloud where the snow is just starting to melt and has the high dielectric constant of water combined with the large dimensions and non-spherical shape of the snowflake. It is characterised by the fact that it appears on the Channel A display, otherwise free or nearly free of rain and by the fact that adjustment of the gain and phase controls in Channel C effect no further improvement. The limitation lies entirely in the shape of the precipitation particles. The degree of cancellation obtainable usually lies within  $\pm 1$  db of 17 db but occasionally departs from it in either direction. There has been observed a correlation between this figure and the type of weather; the cancellation improves to about 20 db under conditions of fine steady drizzle with little wind, but deteriorates under thunderstorm conditions when the precipitation is local and turbulent and consists of very large particles. On 15th June 1953 it fell as low as 13 db for one particular shower. There is just a chance that this last figure was connected with some specular reflection from wet roofs in front of the radar site. Possibility of further trouble has now been removed but it is not worth while to delay publication till after further thunderstorms.

SECRET

The degree of cancellation obtainable using crossed plane polarisation has not been measured very often but is consistently somewhat better than that obtainable using circular polarisation. The difference is of the order of 2 db and is consistent with the following reasoning.

The rain cloud may be regarded as composed of drops of varying ellipticity and of random orientation. Suppose we consider, at first, just those drops of a certain ellipticity. The echo from each of these will be elliptically polarised to the same extent but with an axis in an arbitrary direction, being a function of the orientation of the major axis of the drop itself. The echo from each drop can therefore be resolved into a circularly polarised component and a plane polarised component of arbitrary orientation and constant amplitude. The circularly polarised component can be completely eliminated by the radar, leaving only the residuum which clearly behaves like a number of arbitrarily orientated dipoles, each of the same length.

The behaviour of such a cloud of dipoles is also of interest in estimating the behaviour of a Window cloud (provided that due allowance is made for the fact that the orientation is not random) and can be ascertained by considering and integrating the echo from one dipole as it rotates.

Let us assume that the power returned from such a dipole when parallel to the incident polarisation is P. Now if the dipole lies at an angle  $\theta$  with the incident polarisation it will extract the component of its own polarisation from the incident radiation, and this in turn must be resolved parallel to the incident polarisation. The voltage of the returned signal is therefore reduced by a factor of  $\cos^2\theta$ .

$$\text{The returned Power } P_{\theta} = P \cdot \cos^4\theta \quad \dots \text{ Eq.9}$$

The total power returned as  $\theta$  varies between 0 and  $\pi$  is given by

$$P_{11\theta} = P \int_0^{\pi} \cos^4\theta \, d\theta = \frac{P}{8} (3\theta + 2 \sin 2\theta - \frac{1}{4} \sin 4\theta) \Big|_0^{\pi} \quad \dots \text{ Eq.10}$$

Similarly the returned power, perpendicular to the incident plane of polarisation from a dipole at angle  $\theta$ , may be found by resolving the dipole voltage perpendicular to the incident plane. The voltage reduction is therefore  $\cos \theta \cdot \sin \theta$  and the resultant power return is

$$P_{\theta}' = P \cos^2\theta \cdot \sin^2\theta \quad \dots \text{ Eq.11}$$

The integrated power perpendicular to the incident polarisation is similarly

$$P_{\perp} = P \int_0^{\pi} \cos^2\theta \sin^2\theta \, d\theta = \frac{P}{8} (\theta - \frac{1}{4} \sin 4\theta) \Big|_0^{\pi} \quad \dots \text{ Eq.12}$$

In both these expressions the  $\sin 2\theta$  and  $\sin 4\theta$  terms become zero and we have the simple result

$$\frac{P_{11\theta}}{P} = \frac{3}{8} \quad \dots \text{ Eq.13}$$

$$\frac{P_{\perp}}{P} = \frac{1}{8} \quad \dots \text{ Eq.14}$$

SECRET

If we radiate circularly polarised waves to a dipole target, the power returned is independent of the orientation of the dipole, and the extent to which it is energised may be found by resolving the C.P.W. into two equal plane components, one perpendicular to the dipole and which is completely decoupled from it and one component parallel to it. The power reduction is clearly 3 db. The plane polarised component, re-radiated by the dipole, is split equally between Channel A and Channel B and we therefore may summarise the results in the following table.

<u>Radiated Polarisation</u>	<u>Target</u>	<u>Parallel Component</u>	<u>Perpendicular Component</u>	<u>Channel A</u>	<u>Channel B</u>
Vertical	Vertical Dipoles	0 db	- 00 db	-	-
Vertical	Horizontal Dipoles	- 00 db	- 00 db	-	-
Vertical	Random Dipoles	-4.2 db	- 9 db	-	-
Circular	Vertical Dipoles	-	-	-6 db	-6 db
Circular	Random Dipoles	-	-	-6 db	-6 db
45°	Vertical Dipoles	- 6 db	- 6 db	-	-

The validity of this argument is not affected by the ellipticity of the drops chosen, and the same ratios obtain when we integrate the power from all drops, no matter what their ellipticity may be.

It is worth noting that the total power returned to the radar from the random dipoles is half that which would be returned by dipoles parallel to the incident polarisation ( $\frac{P}{8} + \frac{P}{8}$ ) and that the same total power is returned when circular polarisation is used ( $\frac{P}{4} + \frac{P}{4}$ ). The residual signal in the rain cancelled channel is, however, 3 db less when using crossed plane polarisation than when using circular polarisation (-9 db compared with -6 db), which agrees reasonably with our observations. More than this amount is lost, however, on wanted targets. (Ref. 3).

Normal rain in Channel A: On nearly all occasions when measurements have been made, other than in the bright band, the rain has been made to disappear completely into the receiver noise. Three measurements of the order of 29-30 db have been made during light rain but during thunder showers the ratio has been less, falling (on 15th June 1953) to 23 db.

Normal rain in Channel C: As mentioned earlier, it has not been easy to find rain which produces a sufficiently intense echo to make an accurate measurement of the cancellation ratio in Channel C, but there has been one measurement better than 35 db. The limitation, as usual, was the reduction of the rain signal to a level comparable to that of the receiver noise. Further measurements are required before confirmation is obtained of the theoretical figure of 40 db quoted in 6.1.4, and the practical results will, in any case, depend on the sphericity of the raindrops. This does not seem to be maintained during heavy thunder showers.

#### 6.1.6 Comparison with other results

The most recent figures are those of I.C. Browne<sup>9</sup> at Cambridge working on 3.2 cm. and N.P. Robinson<sup>9,10</sup> at Malvern, working on 8 mm. For measurement in the bright band, our fairly consistent figure of 17 db, using circular polarisation, presumably corresponds to 19 or 20 db using crossed plane polarisation. Browne's figure of  $16.9 \pm 0.3$  db using crossed plane polarisation is lower than our figure, though not inconsistent with some of our extreme readings. The other discrepancy is the large spread of our readings

SECRET

compared with the small spread of Browne's, and we are unwilling to attribute this to variations in the equipment in view of its measured parameters, its performance on other targets and the fact that different clouds seen at the same time, gave different results. It is however possible that the "bright band", which is not well defined during thunderstorm conditions, is not strictly comparable to the well defined band at uniform height normally implied by the use of this term. Before any close comparison can be made, it is desirable to know more about the types of rain storm being compared, and the relative performance of the two radars.

The improved cancellation on rain of 30 db in Channel A and up to 35 db in Channel C lends support to the suggestion that Browne's limitation of 22 db  $\pm$  0.4 db on rain was set by the aerial of the radar rather than the nature of the droplets. Here again we have been unable to repeat the consistency of results of either Browne or Robinson.

Only one rough measurement has been made on snow, so it is unwise to make any serious comparison with Browne's figures. The snow took the form of fine wet sleet at ground level, settling as snow at about 700 feet. For what it is worth, a measurement made at 3000 feet gave a cancellation of not less than 26 db. Measurements in the melting band, presumably near ground level, were not possible owing to interference from permanent ground echoes.

Robinson's results on 8 mm, using cross polarised plane waves<sup>4,9</sup> and circular polarisation<sup>10</sup> agree well with each other but are clearly of a different order to those on X band. The substantially lower cancellation (5-11 db for the melting band and 17 db for rain) are possibly due (as suggested by Robinson) to the approaching resonance of the rain and snow particles. This seems more likely in the case of the melting band where there is a large statistical fluctuation, than in the case of normal rain where a large number of Robinson's results agreed very closely. More readings are undoubtedly needed on X band so that the consistency of cancellation ratio can be measured.

The results on S band should be at least as good as on X band and may be somewhat improved as the frequency is farther from resonance.

6.1.7 Photographs of rain displays

Fig. 22a and 22b are photographs of the normal display showing Channel A rain free, except for vestigial bright band signals and Channel B with rain. The A + B display is of some interest as the test pulse can be seen, superimposed on the rain signals. This is an improvement over the conventional plane polarised radar, which has a similar maximum range (see Section 4.11) but in which saturation by rain signals entirely prevents detection of the wanted signal.

Fig. 22c shows a comparable display with a plane polarised transmitter. Channel A represents the parallel component of the echo and Channel B, now rain free, represents the perpendicular component.

Fig. 22d shows the case where the vertical and horizontal components of the echo are displayed and where the rain is illuminated with circular polarisation. The echo fluctuations affect primarily amplitude and not circularity, so that the V and H components fluctuate simultaneously. The V-H display is therefore rain free. In passing, it might be noted that if the Channel C phase shifter is now adjusted to replace V and H by 45° right and 45° left respectively, we have a display free simultaneously from circularly polarised, vertically polarised and horizontally polarised signals. This is probably only of academic interest, as it represents a rural landscape from which most man-made targets have been removed. The reverse process, is unfortunately, not so easy.

## 6.2 Echoes from Window Jamming

Whereas rain echoes provide one sort of elementary target, namely a collection of dielectric spheres, the echo from the ideal window jammer provides another sort of elementary target, namely a collection of randomly orientated dipoles (see also 6.1.5). One would expect a target of this sort to produce echoes composed of equal mean signals in Channels A and B, and with all types of Window so far measured this is found to be so. More than 20 drops have taken place in a variety of wind conditions between 6 and 20 knots on the ground and no difference has so far been detected between the mean value of Channel A and Channel B signals. About one minute after drop, the Window cloud occupies more of the radar beam, so that the beat rate becomes very rapid and the A - B display shows a signal fluctuating symmetrically about the zero line. The rate of beat becomes much faster than that of aircraft echoes (see Section 6.4) which may also show an anti-symmetrical or symmetrical tendency for period of several seconds; and given time for integration, as with a tracking radar for example, there seems little reason why echoes from Window jamming should not be very greatly reduced in intensity compared with the wanted echoes. The value of this facility may be somewhat reduced by the increase in fluctuation rate of aircraft echoes when the aircraft is changing its aspect rapidly. More detailed analysis will be required to settle this point.

Of more immediate interest were measurements made of relative horizontal to vertical echoing area of the different types of Window. The fact that there was a preponderance of horizontal over vertical echoing area on all occasions in no way invalidates the theoretical basis underlying the last paragraph, as the excess horizontal dipoles can be regarded as producing a horizontally polarised signal which is balanced out on the A - B display, leaving a collection of randomly orientated dipoles giving a smaller residual signal symmetrical about the zero line.

The Window signals, as they appear in the V - H type of display, are shown in Fig. 23a-c. The unbalance is clearly due to the increased horizontal echoing area and can be removed by inserting a known attenuation in the horizontal receiver channel. This gives a measurement which is repeatable to within 1.5 db at any one time, provided that 15 seconds has elapsed since the drop. Before this time, the fluctuation rate is slower and the V-H ratio is changing from (presumably) 0 db, corresponding to the turbulent conditions in the slipstream, towards that value which is a function of the type of Window itself. The repeatability of this type of measurement can be estimated from Fig. 30, which shows the H/V ratio for two types of Window, plotted as a function of time after drop.

Terminal values in the case of two different types of Window have been found to be 8-9 db for RR.124/U and 13-15 db for XWB/X/1. The former is weighted to make polarisation more random, but there is still clearly room for improvement in this respect.

More recently, some drops have taken place of Window of different lengths but otherwise identical. Close repetitive agreement has been found in the results which are as follows:-

Length	H : V Ratio
$\frac{3\lambda}{2}$	7 db
$\lambda$	10 db
$\lambda/2$	15 db

In this measurement, no attempt was made to weight the material.

SECRET

Superficial examination has been made also of the distribution of material in Window clouds. Some minutes after dropping there has been recorded a difference of 3 db in the H/V ratio between the top and the bottom of the cloud, the ratio being larger at the top. This difference is more noticeable when the wind gradient with height is steep and the Window cloud needs different attenuator settings to balance it throughout its extension in range.

6.3 Ground Echoes

The radar was situated at a height of approximately 230 feet and was used to survey the terrain which sloped gently away from it. The ground was fairly well wooded but contained no appreciable built up areas. There were a number of isolated houses and farms.

Transmission Circular. Comparison of A and B: As with the rain, three types of measurement were made in order to investigate the nature of the various echoes. The most important was the radiation of circularly polarised radiation and the comparison of the signal levels in Channels A, B and A-B. It was found that echoes could be divided into three different types. The overwhelming majority of the targets produced echoes of nearly equal mean power, although the instantaneous power was fluctuating rapidly. The A-B display therefore presents a confused mass of echoes beating on both sides of the zero line. There appeared to be a slight general bias in favour of symmetry, amounting to about  $1\frac{1}{2}$  db, though of course the amount varied from target to target. As the ground wind speed is reduced the beat rate falls until dead calm is reached. Under these conditions the trace is almost stationary, with each echo being polarised to an arbitrary ellipticity dependent upon the fortuitous addition and cancellation of the constituent components.

There appears to be a difference between winter and summer behaviour, in that in winter a wind velocity less than 8 knots or thereabouts permits the beat rate to slow down and the individual echoes to develop a positive or negative tendency. The corresponding wind velocity in the summer is of the order of 2 to 3 knots, presumably because the branches of the trees are then in full leaf.

Among these randomly polarised echoes, certain others immediately stand out on the A-B display. They are either symmetrical echoes or anti-symmetrical echoes and are usually very steady in amplitude and independent of wind velocity. It is reasonable to expect them to come from man-made structures and those which have been physically investigated have, in fact, done so. Owing to the limitations of the site, there have not been a large number but it is of interest that all the symmetrical echoes located have presented curved surfaces to the radar. Typical examples, a house with a large bow front, and a corrugated iron barn-wall are shown in Figs. 24a-24b. It may be that a real plane sheet requires very close tolerances on viewing angle, to be seen, so that the curved surfaces, though of smaller echoing area, form a larger proportion of symmetrical targets seen. Change of radar site will settle this point. One anti-symmetrical target was seen and located. One associates this type of echo with a diplane and in fact the building had several.

Transmission Plane. Comparison of Parallel and Perpendicular: This last target was also illuminated with plane polarisation and behaved in an exemplary manner. When the polarisation was vertical or horizontal the echo was predominantly parallel to the radiated polarisation. When, however, the radiated polarisation was  $45^\circ$  left or right, the echo was polarised predominantly perpendicular to the radiated polarisation. This is according to theory, and it is interesting to note that a vertical or horizontal diplane both behave identically in this respect and cannot be distinguished by any radar unless the total path length is known to a fraction of a wavelength.

SECRET

Transmission Circular. Comparison of V and H: A V-H display of permanent echoes also gave interesting results. The overwhelming proportion of the echoes had no bias towards horizontal or vertical so that so far as rural terrain is concerned, there is no preferred polarisation on X band to minimise permanent echoes. A small number of echoes stood out as predominantly vertical and are shown in Figs. 25a and 25b. In the first case the V/H ratio was no less than 26 db, and the reasons are quite clear from inspection. Electricity pylons and church spires also produced echoes which were steadily polarised with a tendency to one particular plane, though usually not more than several decibels. It is interesting to note that the lightning conductor, which is presumably the chief source of echo in Fig. 25a, entirely masks any diplane tendency there may be.

Target discrimination

The comparative stability of the polarisation properties of echoes from man-made targets offers a prospect of separating these from rural echoes under the right conditions. Those conditions are threefold, and the first is that the ground wind must have a force greater than a certain minimum if the unwanted echoes are to be properly integrated and tend to zero. For X band the minimum is of the order of 3 knots in summer and 8 knots in winter. For higher frequencies it is reasonable to expect the minimum usable wind speed to be decreased and vice versa.

The second condition is that there must be time enough to integrate the unwanted echo, and here again conditions favour the use of a high frequency. In general, difficulty will be experienced with a scanning radar on this account, unless the scanning rate is kept low. The fluctuation time will, of course, vary with wind speed and appears to be of the order of 0.1 - 0.2 seconds for this minimum usable speed.

The third condition is that imposed by the use of the radar in a moving vehicle or aircraft. The reflection lobes of any complex target will undoubtedly vary with polarisation, so that echoes will fluctuate as the searching radar moves, even if the constituent components of the target are stationary. The rate at which the radar flies through the lobes is likely to be considerably slower than the movement of the lobes from rural areas, particularly if there is a large component of the aircraft velocity in the direction of the target; and, except when the searching radar is close to the target, it should be possible to choose a time constant which enhances echoes from built-up areas compared with those from rural echoes. The position is analogous to the case where an aircraft is seen from a ground radar. The rate of echo fluctuation increases by an order or more when the aspect is changing, compared with the rate when the aircraft is presenting a nominally constant nose or tail aspect.

One might expect that the echo from a town might come primarily from 3-face corner reflector (two walls at right angles and the ground) and from diplanes (one wall and the ground). If this is so, there might be some advantage to an H<sub>2</sub>S type of radar to transmit 45° right hand plane polarisation and to receive 45° left hand plane. Such a system will reduce rural echoes by about 10 db, a figure supported by practical measurement (Fig. 26) but echoes from vertical or horizontal diplanes will be unaffected. The extent to which these contribute to the echoing area of a town can only be found by measurements from a suitable raised site.

6.4 Aircraft Echoes

These are the most difficult targets not only from which to produce repeatable results but to produce figures at all, because the echoing properties are a very critical function of the aspect which is constantly changing. We have confined ourselves to measurements of a nominal nose and tail aspect but, even under those conditions, the results may vary considerably from second to

SECRET

second. It would, of course, be possible to photograph the various components of the echo which we wish to compare and then plot out pulse by pulse the power level in each channel. Integration gives the mean power in the echo. Such a process would be extraordinarily tedious so a shorter method was attempted. The echo was photographed for periods of the order of seven seconds spaced arbitrarily during its run. For each frame (about 30 pulses) a note was taken of whether A was greater than, equal to or less than B. It was then intended to repeat the runs with differential gain settings until approximate equality between A and B was achieved.

In practice this was not very satisfactory owing to the large variations in results not only between runs, but at different times during the run. Therefore a slightly different approach was adopted. A number of permanent echoes were photographed with a succession of different differential gain settings. The relative number of  $A > B$ ,  $A = B$  and  $B > A$  frames was noted and plotted as a function of the gain difference. All the curves were of the same general shape, differing only in the position of the crossover point. A sample curve is plotted in Fig. 27a, and this was used to give an estimate of the relationship between differential signal power and the proportion of excess or deficit A to B signals. The curve does not agree with the theoretical curve (Fig. 27b) derived from the scalar difference between two signals of varying differential power, each having a Rayleigh distribution of amplitudes; but departs from it by a factor of about two in the decibel scale.

Analysis does not reveal any obvious reason for this factor of two but a possible explanation lies in the stability of the signals being compared. If the two signals were constant in amplitude, the curve produced would be a step function (Fig. 27c). Actual targets are likely to lie somewhere between the limits of Fig. 27b and 27c, and aircraft, which presumably have a smaller number of echoing points, might on this reasoning lie between 27a and 27b, i.e., the curve 27a gives a pessimistic impression of the amplitude fluctuations in relation to the actual observations recorded. Such errors as there are will be greater for large power differences and will tend to zero when the powers in the two signals tend to equality.

With this tentative hypothesis in mind, it is possible to draw some conclusions from the preliminary results shown in Figs. 28 (a-d). All aircraft runs were nominally for nose or tail aspect, but the tolerance on bearing at any one time was probably not closer than  $+ 5^\circ$  and may have been rather more during some of the nose runs during conditions of bad visibility. When the results have been integrated they are found to be clustered closely about the 0 db mark (Fig. 29) with no very great difference between the mean level of the A and B signals. The total spread is of the order of  $\pm 2$  db, which corresponds to a rain-free signal level between  $1\frac{1}{2}$  and  $3\frac{1}{2}$  db below that obtained from a practical plane polarised radar of similar design parameters.

The shorter term fluctuations are, of course, more extensive, and our figures show the result of integration over periods of the order of seven seconds. The extreme ratios of A to B obtained were -7 db and +10 db, which correspond to a rain free signal of  $-7\frac{1}{2}$  db and  $-\frac{1}{2}$  db respectively compared with a plane polarised radar. The likely extremes are probably well within these limits because the method of assessment gives undue prominence to steady and extreme values.

Still shorter term fluctuations (e.g., pulse to pulse) have not yet been studied with this equipment. Exposure at 64 frames per second, and reduction of repetition rate, yields frames each the integral of five pulses. With small jet aircraft, which have an amplitude fluctuation rate slower than that of piston engined aircraft, there is little evidence of rapid pulse to pulse fluctuations in the A to B ratio, unless the aircraft aspect is changing rapidly.

SECRET

In the measurements so far made of the ratio of vertical to horizontal echoing area (when illuminated with a C.P.W.), again integrated over periods of seven seconds, the fluctuation amplitude is appreciably less than that of the A to B ratio. For such periods, the V to H ratio seldom exceeds the limits of  $\pm 2$  db and for the integrated run, the difference between V and H echoing area does not exceed 1 db for the aircraft so far measured.

This information gives some food for thought on the mechanism of aircraft reflections and it is clear that our original conception of an aircraft as a randomly orientated collection of dipoles<sup>6</sup> must be abandoned. While it is true that such a target could momentarily produce signals which are predominantly anti-symmetrical, it is scarcely conceivable that the aircraft could maintain its orientation for fifteen seconds or so, to such an extent that the vertical-horizontal phase displacement in the complex echo does not shift by more than  $\pm 90^\circ$  (1.5 cm).

We must also regard with suspicion the theory that the aircraft may be regarded as a number of discrete bounce points normal to the incident radiation. The nature of any such point must be essentially symmetrical and the addition of any number of similar points, though producing fluctuations of amplitude, cannot alter the general nature of the polarisation. The dominance of Channel B, which one would expect from this theory, is in no way supported by the facts.

The substitution of a theory which fits in with the observations is, of course, more difficult and at this stage suggestions must be regarded as tentative. One possibility is that diplanes do, in fact, make a significant contribution to the echoing area of the aircraft. They would be broadly directional and from certain aspects they might well produce larger signals than those coming from the "symmetrical" parts of the aircraft, though producing an amplitude interference pattern among themselves. Such diplanes might exist between the wings and the fuselage, the wings and the engine nacelles, and among the various protuberances around some older aircraft engines. It is not so clear where they could occur when viewing from the tail aspect, since the trailing edges of the wings, tailplane and rudder usually have sharp edges. There is not yet enough statistical backing to say that the slightly reduced tendency to anti-symmetry in the tail aspect supports this suggestion.

It is interesting to note that the apparently coarser scattering diagram for the symmetrical and anti-symmetrical components of the echo compared with the vertical and horizontal components is consistent with the above hypothesis. With the type of radar described, the A and B signals are separate and cannot interfere with each other, whereas the vertical (say) components of both symmetrical and anti-symmetrical parts of the target can so interfere.

A different treatment is to regard parts of the target such as the wings as coherent electrical structures which have a scattering diagram consistent with a particular induced voltage and phase distribution. It has been suggested by J.D. Clare<sup>7</sup>, that if the radii of curvature over the surfaces are larger compared with the wavelength, the scattering diagrams for vertical and horizontal polarisation will not be very different, and the lobe width will be slightly different for the two polarisations. If there is a range of aspect angles over which the width of the reflection lobes is constant for each polarisation, there will be angles covering several lobes where the V and H lobes are in phase, and then after a gradual creep in phase, angles covering several lobes where the V and H lobes are out of phase. When using circular polarisation, this corresponds to aspect angles of symmetry and anti-symmetry respectively.

---

<sup>7</sup> Radar Research and Development Establishment.

SECRET

The experimental evidence so far obtained is inadequate to differentiate between these two theories, and further work will have to be done. One possibility is to add to the effective diplane content of an aircraft, by, for example, putting down air brakes, where these are of suitable shape. Another possibility is to use polarised light to examine the nature of reflections from various aircraft surfaces, and a laboratory examination of a painted diplane illuminated by  $45^\circ$  polarised light has confirmed the possibility of this method. It is hoped that both types of investigation will be carried out in the near future.

7. CONCLUSIONS AND RECOMMENDATIONS

7.1 A radar of this sort is a useful tool in the analysis of the polarisation properties of radar echoes of all sorts. Where there is reason to suppose that the polarisation properties of the targets differs markedly with frequency, there seems justification for building a similar equipment to work at other frequencies.

7.2 The potential cancellation of precipitation echoes is considerably in excess of the limits imposed by the precipitation itself. This is achieved without necessitating close design tolerances or a high degree of circularity in the transmitted wave. The usual limits are 17 db in the "Bright Band" and 25 to 30 db with rain drops. The maximum range of the radar is unimpaired when there is no rain. Extrapolating to S band, there may be some slight improvement in these figures.

7.3 When it is essential to use a plane polarised radar and when interference from Window jamming is a dominant factor in choosing the polarisation, vertical polarisation should be used. Where there is time to integrate the signals received, there is the possibility that echoes from Window jamming can be reduced relative to aircraft echoes. Intensity modulation of the display tube with V-H signals, will reduce window echoes relative to aircraft echoes.

7.4 When used on the ground, a radar of this sort offers hopes of emphasizing echoes from man-made stationary structures relative to echoes from rural terrain (e.g., trees, shrubs, etc.). The possibility of doing this from the air is not ruled out.

7.5 Over a sufficiently large number of runs, there is little difference between the symmetrical and anti-symmetrical components of the echoes from a number of aircraft, when viewed from near-nose or near-tail aspect. This implies a "rain free" signal of level about  $2\frac{1}{2}$  db below that of a plane polarised radar. Over periods up to seven seconds the difference has been found to vary between -7 and +10 db. This implies a rain-free signal level varying between  $7\frac{1}{2}$  and  $\frac{1}{2}$  db respectively below that of a plane polarised radar. These are extreme figures and it is possible that they exaggerate the discrepancy. Both the short term and long term difference between the vertical and horizontal echoing area of aircraft so far tested are less than the corresponding difference between symmetrical and anti-symmetrical components.

7.6 The treatment of an aircraft either as a randomly orientated collection of dipoles, or as a series of bounce points normal to the incident radiation, is unsound. There is not yet sufficient evidence to substitute another theory.

7.7 The equipment should be made transportable so that an analysis can be made of echoes from built up areas as seen from high ground, and also of sea and marine echoes.

7.8 Consideration should be given to the possible identification of aircraft from their polarisation characteristics. This would probably have to be done at a lower frequency than X band and might take the form of the rotation of the plane of polarisation of the transmitted wave in synchronism with a suitable cathode ray tube display.

SECRET

7.9 Measurements should be made as soon as possible on the newest types of aircraft. Their echoing properties, including area, may well be different from those aircraft in current service.

8. ACKNOWLEDGEMENT

I wish to thank my colleagues, Mr. L.H. Mann and Mr. H. Gent, for much stimulating discussion during the course of this work.

AUTHOR: I.M. HUNTER

APPROVED: J.F. ATHERTON

Numbered pages: 24 (27 including Bibliography and List of Figures)

Diag. Nos: RTR 21/3661-66, 4158, 3668, 3669, 3670, 2859, 4140, 4141, 4142.

28th August, 1953

IMH/CJB

SECRET

BIBLIOGRAPHY

1. Goldstein "A primer of Sea Echo", U.S. Navy Electronics Lab. ACSIL 52/1435
2. Clegg, J.E. T.R.E. Report No. T2132, "The back scattering of 3 cm. radio waves from the Earth's surface" 2/6/51.
3. Hunter, I.M. T.R.E. Memorandum No. 460, "Cross Polarisation of Radar Echoes" 6/6/51.
4. Robinson, N.P. T.R.E. Technical Note No. 170, "The effect of cross polarisation on radar echoes at 8 mm. wavelength" 24/9/52.
5. White Circular Polarisation Study. AIL Report 394-1. Airborne Instrument Labs. Minneola, N.Y., U.S.A. September 1950.
6. Hunter, I.M. T.R.E. Memorandum No. 528. Appendix by H. Gent "The use of circularly polarised radiation to reduce interference ... etc." 4/12/51.
7. Simmons, A.J. "A compact Broad Band Microwave quarter wave plate" NRL Report No. 3748.
8. Smith, R.A. T.R.E. Technical Note No. 95, "The relative advantages of coherent and incoherent detectors: A study of their output noise spectra ... etc." 19/9/50
9. Browne I.C. and Robinson, N.P. Nature Vol. 170 P.1078. 20/12/52. "Cross Polarisation of the Radar Melting Band".
10. Robinson, N.P. T.R.E. Technical Note No. 183, "Radar Echoes from aircraft, precipitation and land targets illuminated by circularly polarised radiation at 8 mm wavelength" 21/4/53.

SECRET

T.R.E. TECHNICAL NOTE NO. 196

LIST OF FIGURES

- Fig. 1 Resolution of Elliptically Polarised Wave into orthogonal circular components.
- Fig. 2 Schematic diagram of Echo Polarisation Analysis Radar.
- Fig. 3 Effect on V.E.R. of angle of set of circularising section.
- Fig. 4 Effect on V.E.R. of errors in phase shifting circulariser.
- Fig. 5 Band Width of rectangular guide circulariser.
- Fig. 6 Effect on V.E.R. of tolerances in square guide.
- Fig. 7 Photograph of Plane Resolver.
- Fig. 8 Diagram of Plane Resolver.
- Fig. 9 Photograph of 45° Transition.
- Fig. 10 Diagram of 45° Transition.
- Fig. 11 Asymmetrical Circulariser.
- Fig. 12 Symmetrical Circulariser.
- Fig. 13 Photograph of Waveguide System and Aerial Feed.
- Fig. 14 Schematic Diagram of Phase Bridge
- Fig. 15 Photograph of Display Unit
- Fig. 16 Azimuth Polar Diagram of circularly Polarised Aerial
- Fig. 17 Transmitted Wave. V.E.R. on beam axis.
- Fig. 18 Received Wave. V.E.R. on axis of primary pattern.
- Fig. 19 Received Wave. V.E.R. of secondary pattern as function of position in beam.
- Fig. 20 V.S.W.R. of overall waveguide system.
- Fig. 21 Photograph of assorted waveguide components.
- Fig. 22 (a) Rain Echoes. Transmitting Circular. Comparing A and B. Widespread gentle Rain.  
(b) Rain Echoes. Transmitting Circular. Comparing A and B. Heavy Showers.  
(c) Rain Echoes. Transmitting Plane. Comparing Parallel and Perpendicular.  
(d) Rain Echoes. Transmitting Circular. Comparing V and H.
- Fig. 23 (a) Window Jamming gains equal.  
(b) " " over compensated.  
(c) " " balanced.
- Fig. 24 (a) Symmetrical Target.  
(b) Symmetrical Target.
- Fig. 25 (a) Vertical Target.  
(b) Target.  $V > H$ .  $B > A$ .
- Fig. 26 Permanent Echoes. Transmitting Plane and comparing Parallel and Perpendicular.

SECRET

Fig. 27 (a) Permanent Echo. Plot of Frame numbers against differential gain.  
(b) Video subtraction of two Rayleigh distributions.  
(c) Step function obtained from difference between two steady signals.

Fig. 28 (a) Sample results from Lincoln aircraft.  
(b) " " " Mosquito "  
(c) " " " Meteor "  
(d) " " " Canberra "

Fig. 29 Integrated A:B ratio for various aircraft.

Fig. 30 Window Jamming. Measurements on two types of identical nominal dimensions but different methods of construction.

DRWN.  
CHCK.  
TRCD. DATES  
APPD. DATE  
DATE.

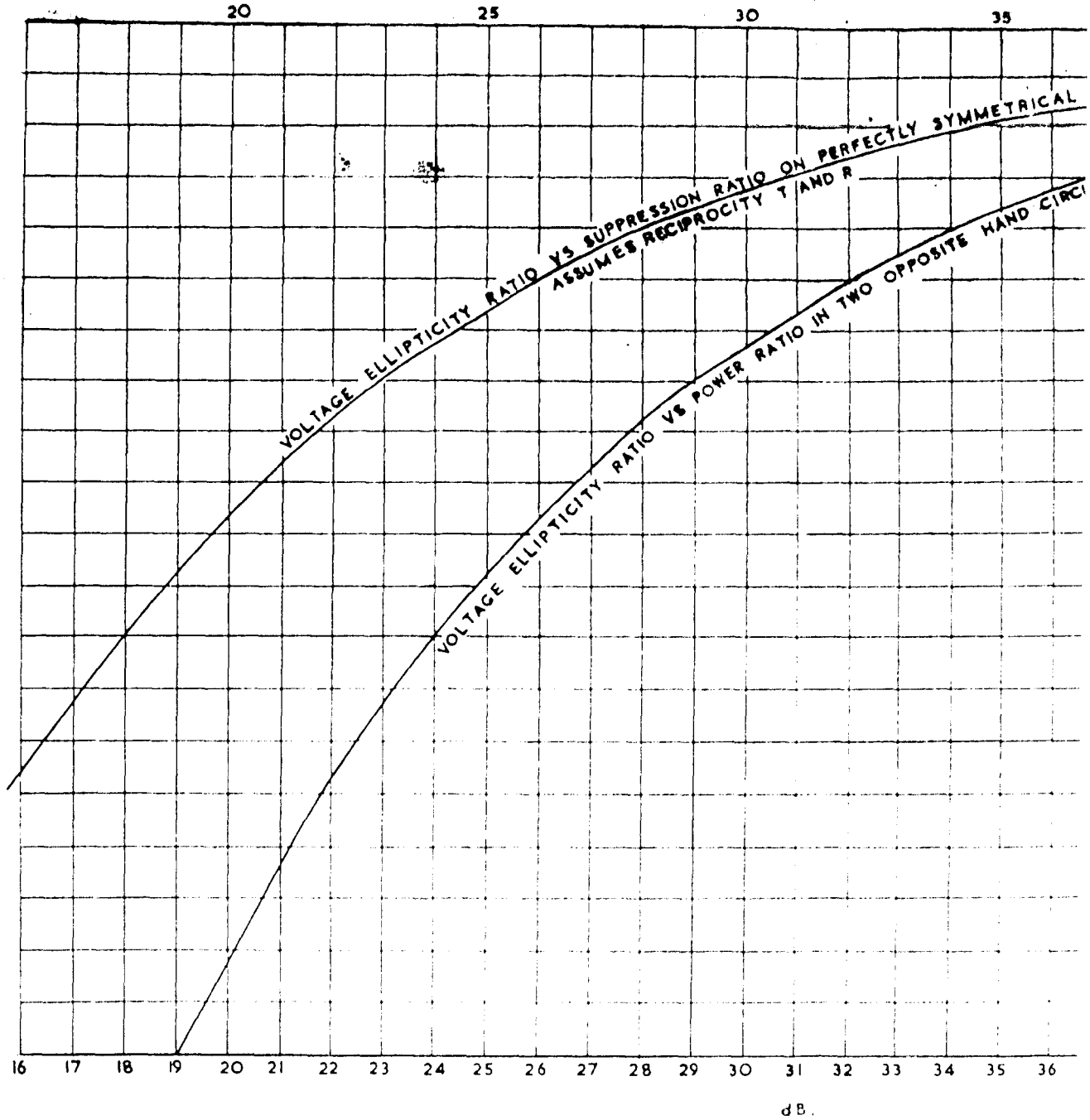


FIG. 1.

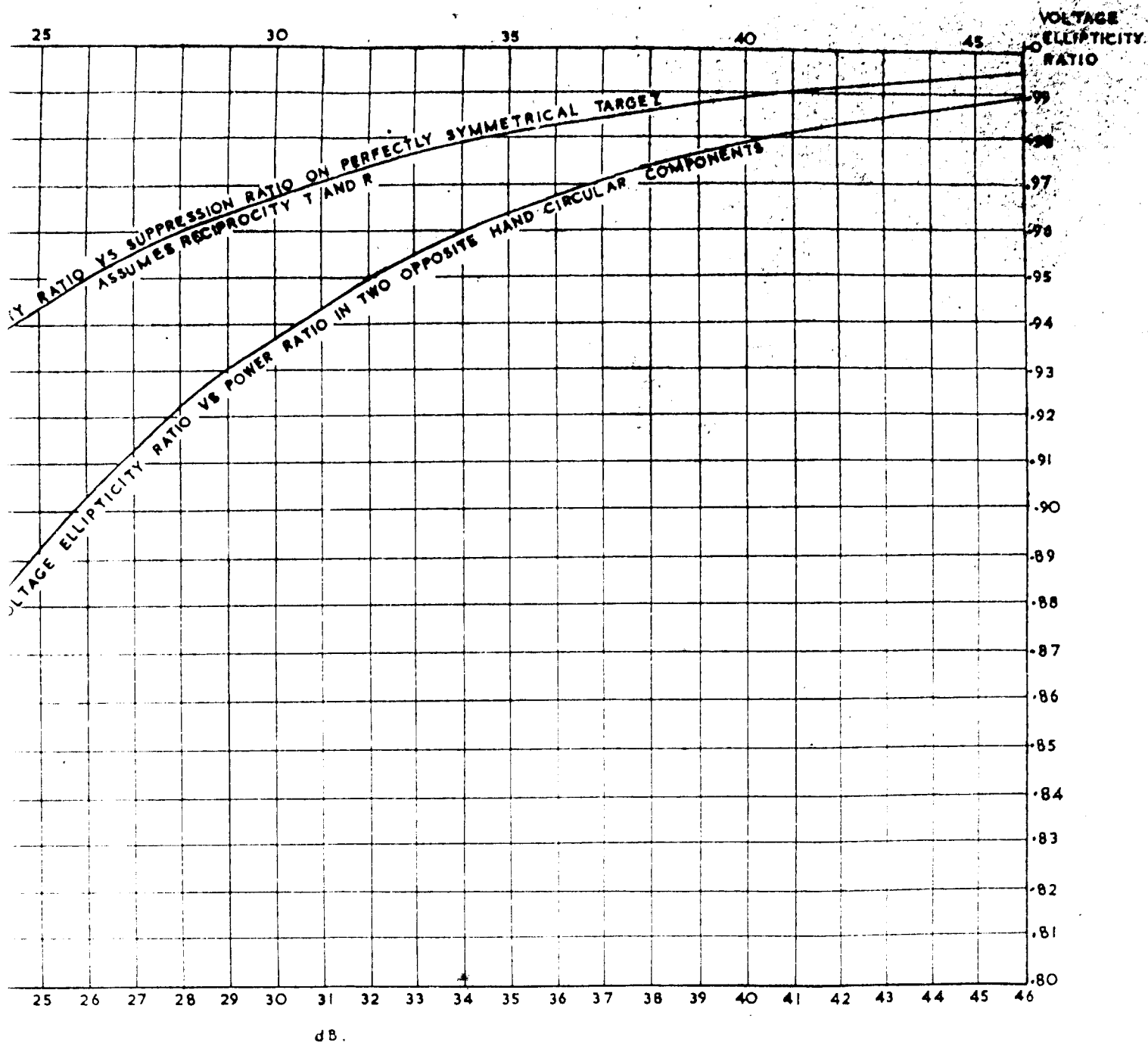


FIG. 1.

CUCY,  
 TRCD 53033.  
 APPD. 87P  
 DATE.

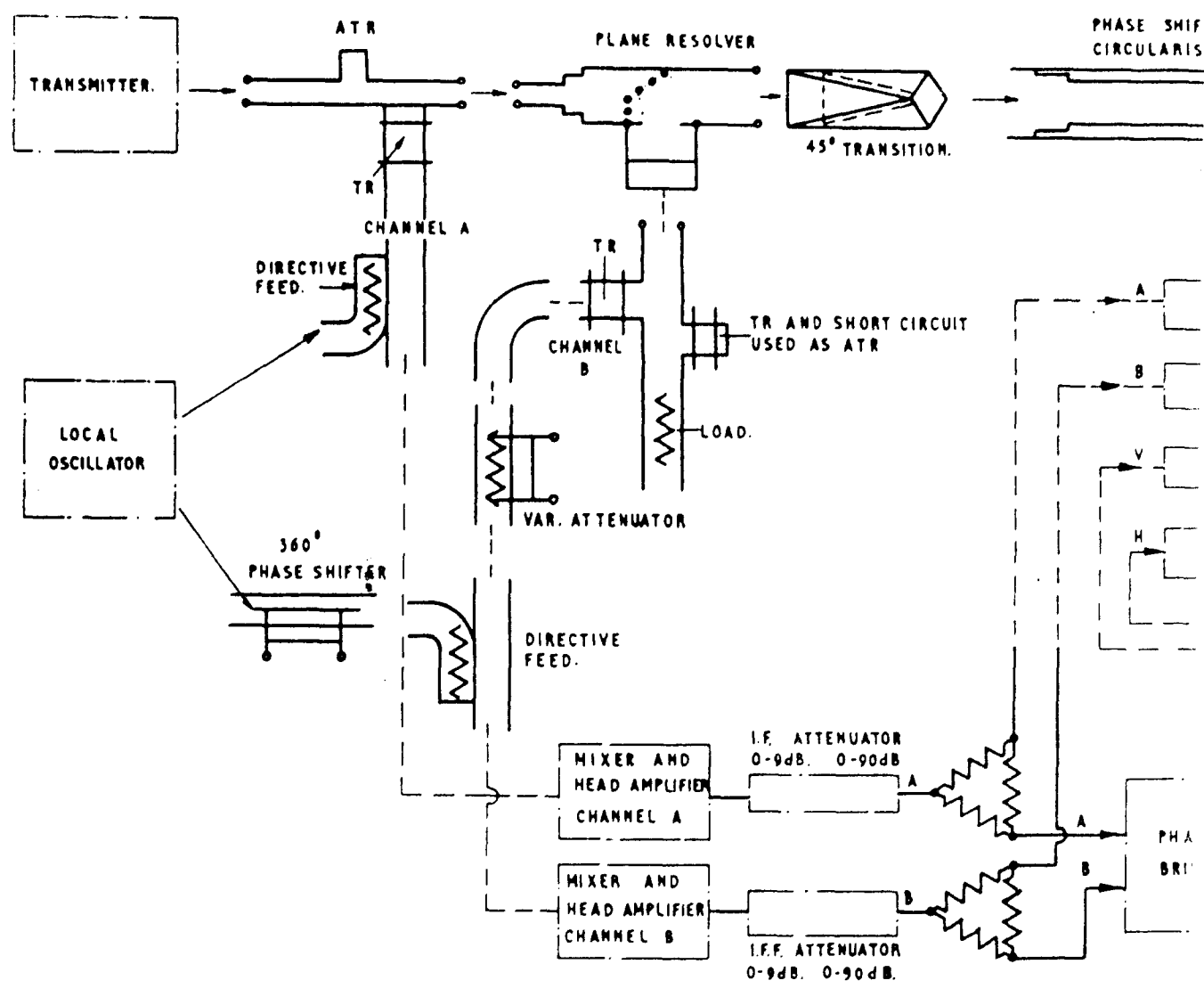


FIG. 2.  
 BLOCK SCHEMATIC DRAWING OF  
 POLARISATION ANALYSIS R

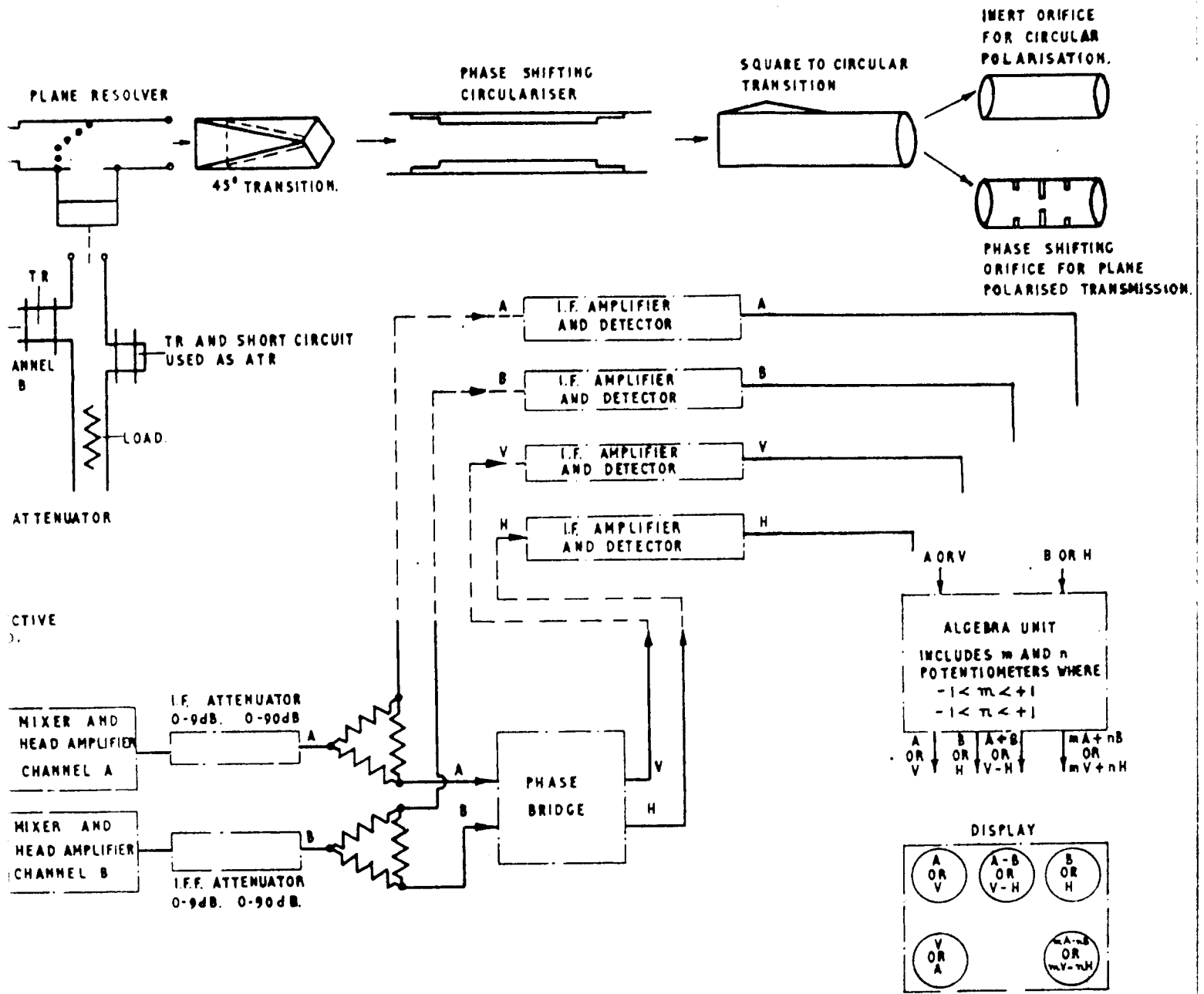


FIG. 2.

LOCK SCHEMATIC DRAWING OF ECHO POLARISATION ANALYSIS RADAR.

DRAWN.  
CHCK.  
TRCD. JAMES.  
APPRO. JTE  
DATE.

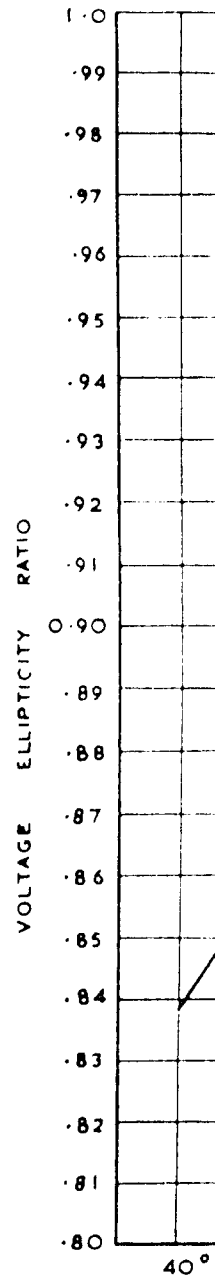
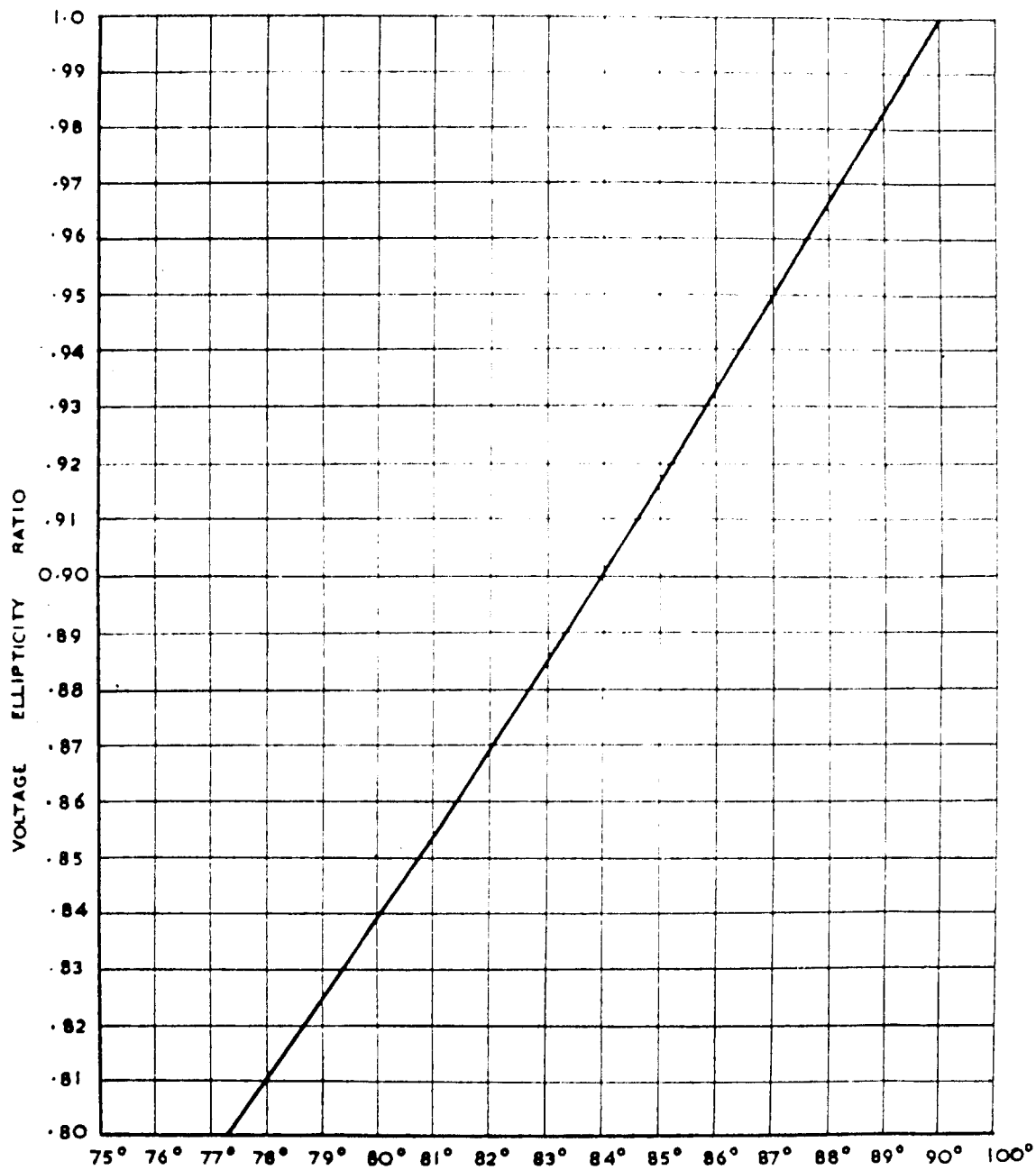
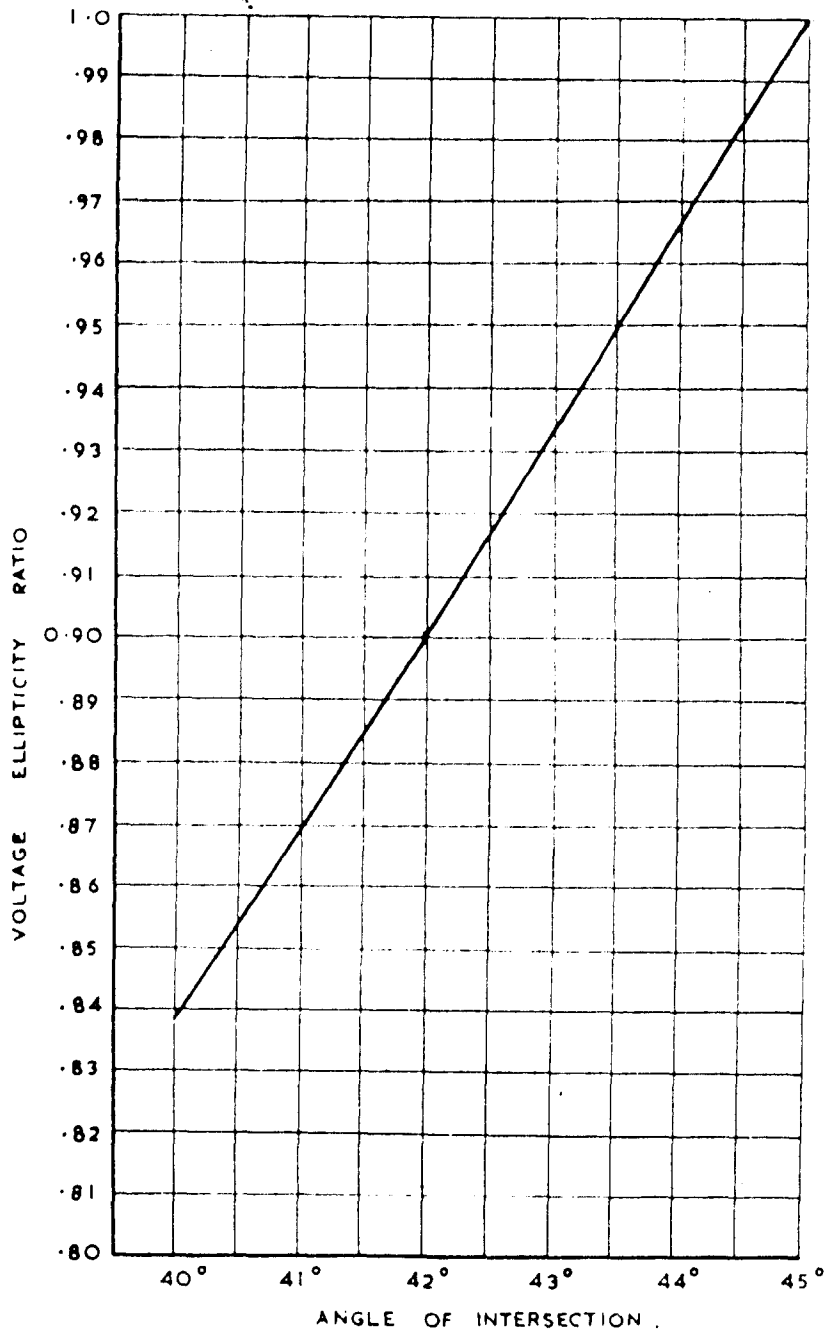
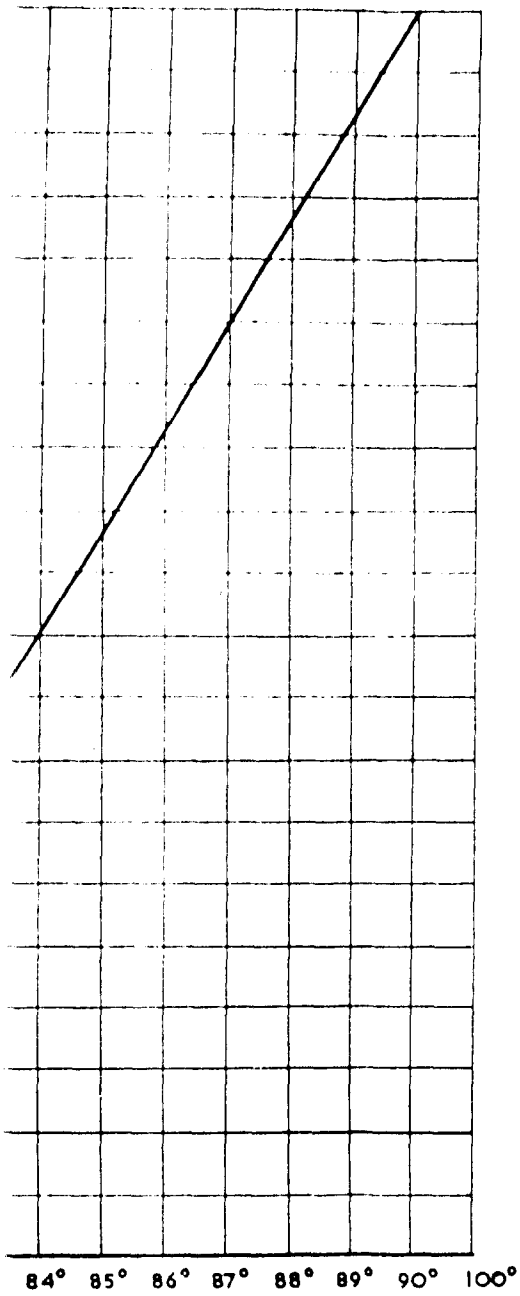


FIG. 4

PHASE SEPARATION BETWEEN TWO EQUAL PLANE  
ORTHOGONAL COMPONENTS.



4

FIG. 3

EEN TWO EQUAL PLANE  
COMPONENTS.

DRWN.  
 CHCK.  
 TRCD. JAMES  
 APPD. 4-11-54  
 DATE.

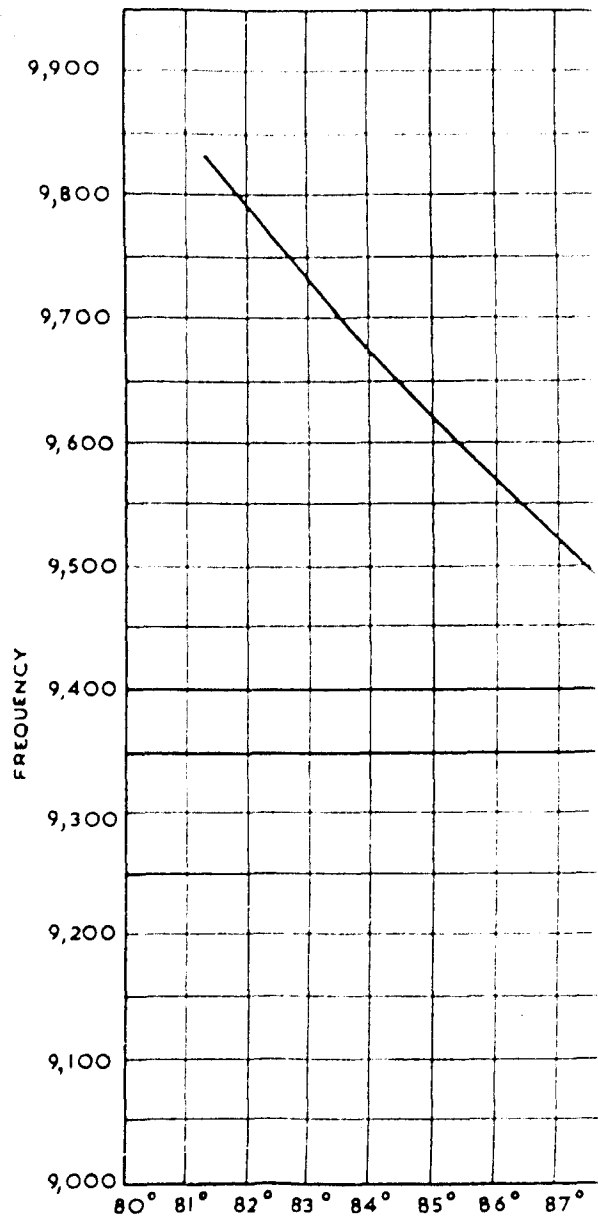
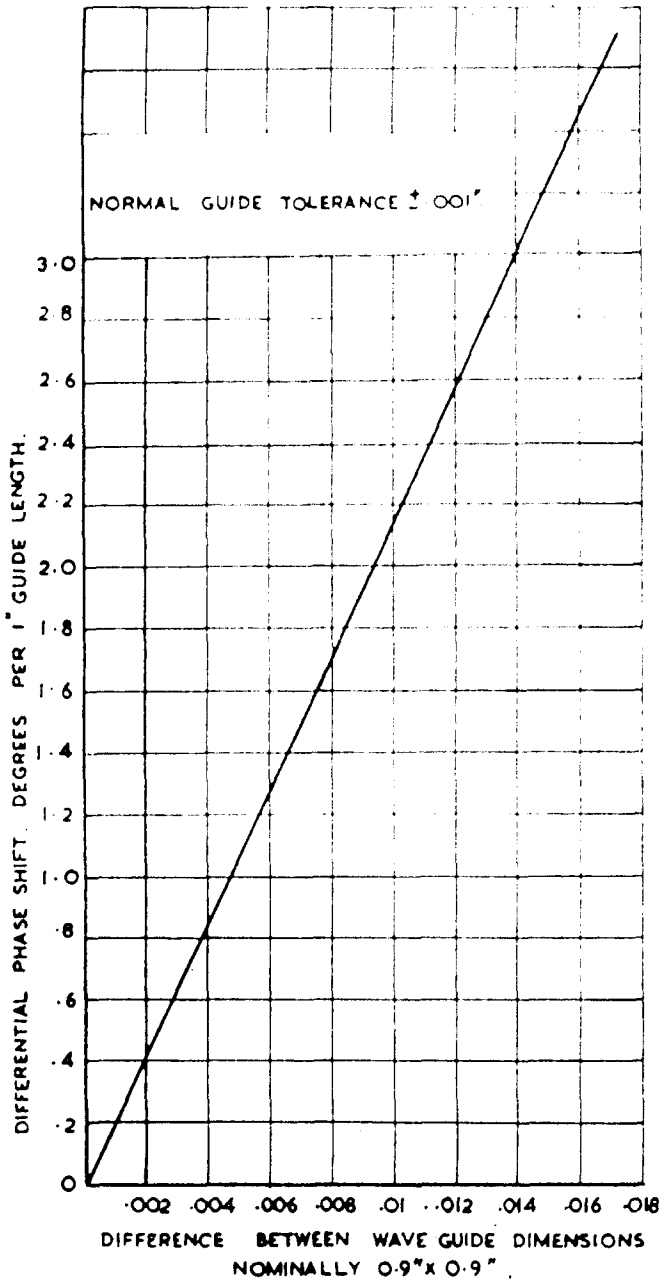


FIG. 6

DIFFERENTIAL P  
 0.8 x 0.9 LENS

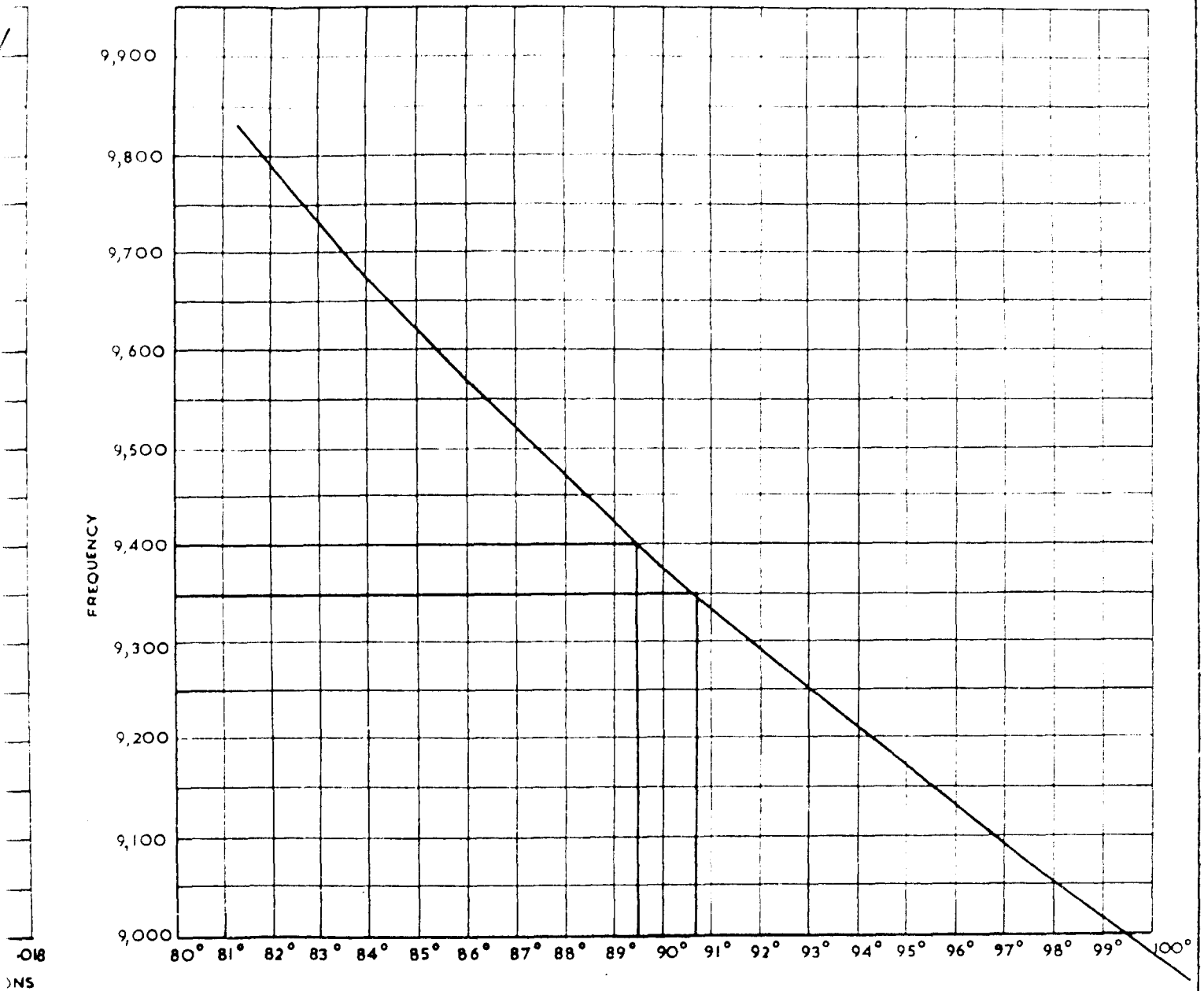
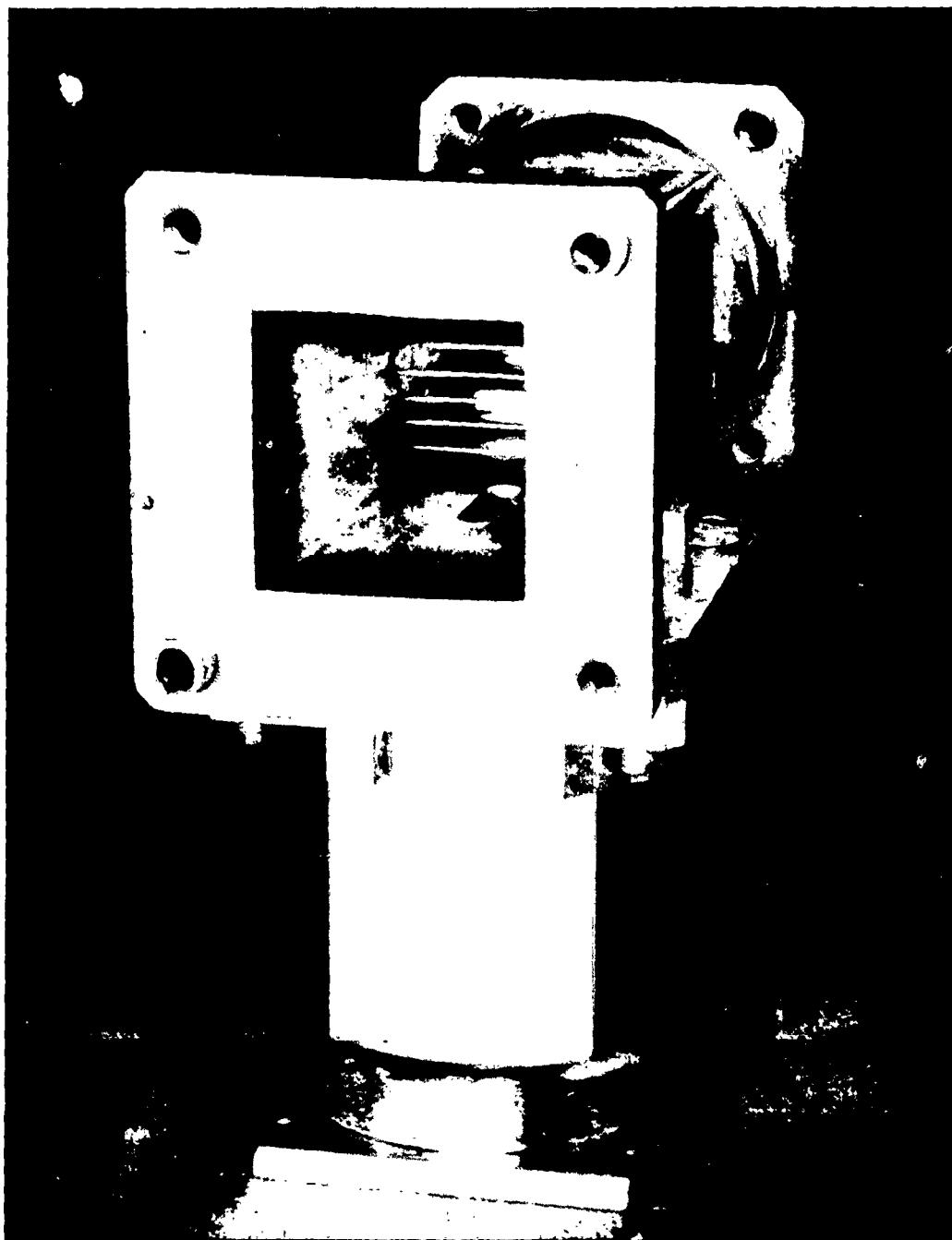


FIG. 5  
 DIFFERENTIAL PHASE SHIFT IN WAVE GUIDE  
 0.8 x 0.9 LENGTH = 3.226" (IGNORING MISMATCHES)



DRN.  
TRCDS  
CHKD  
APP

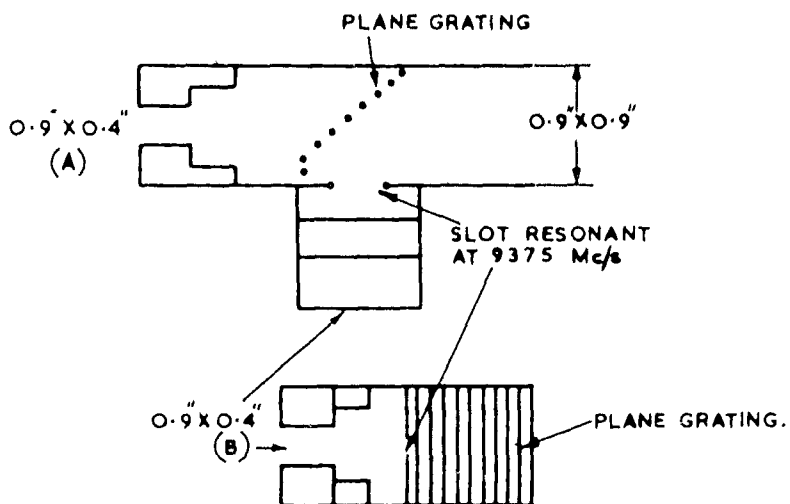


FIG. 8.  
PLANE RESOLVER.

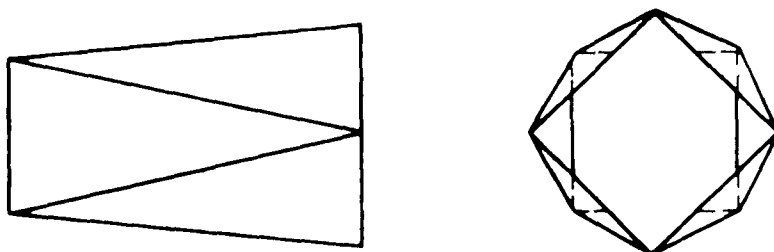


FIG. 10.  
45° TRANSITION.



FIG. 11.  
ASYMMETRICAL PHASE SHIFTER



FIG. 12.  
SYMMETRICAL PHASE SHIFTER.

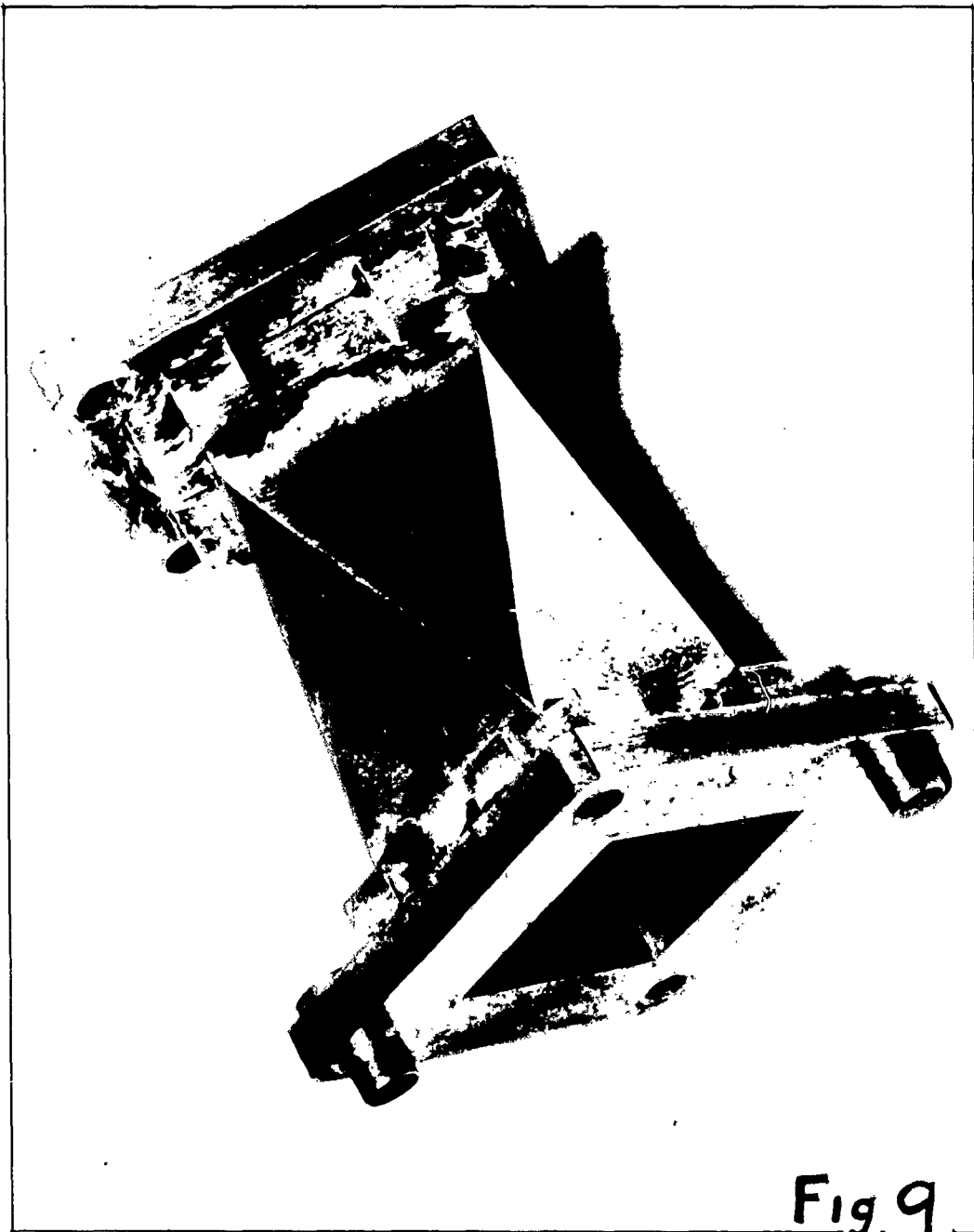
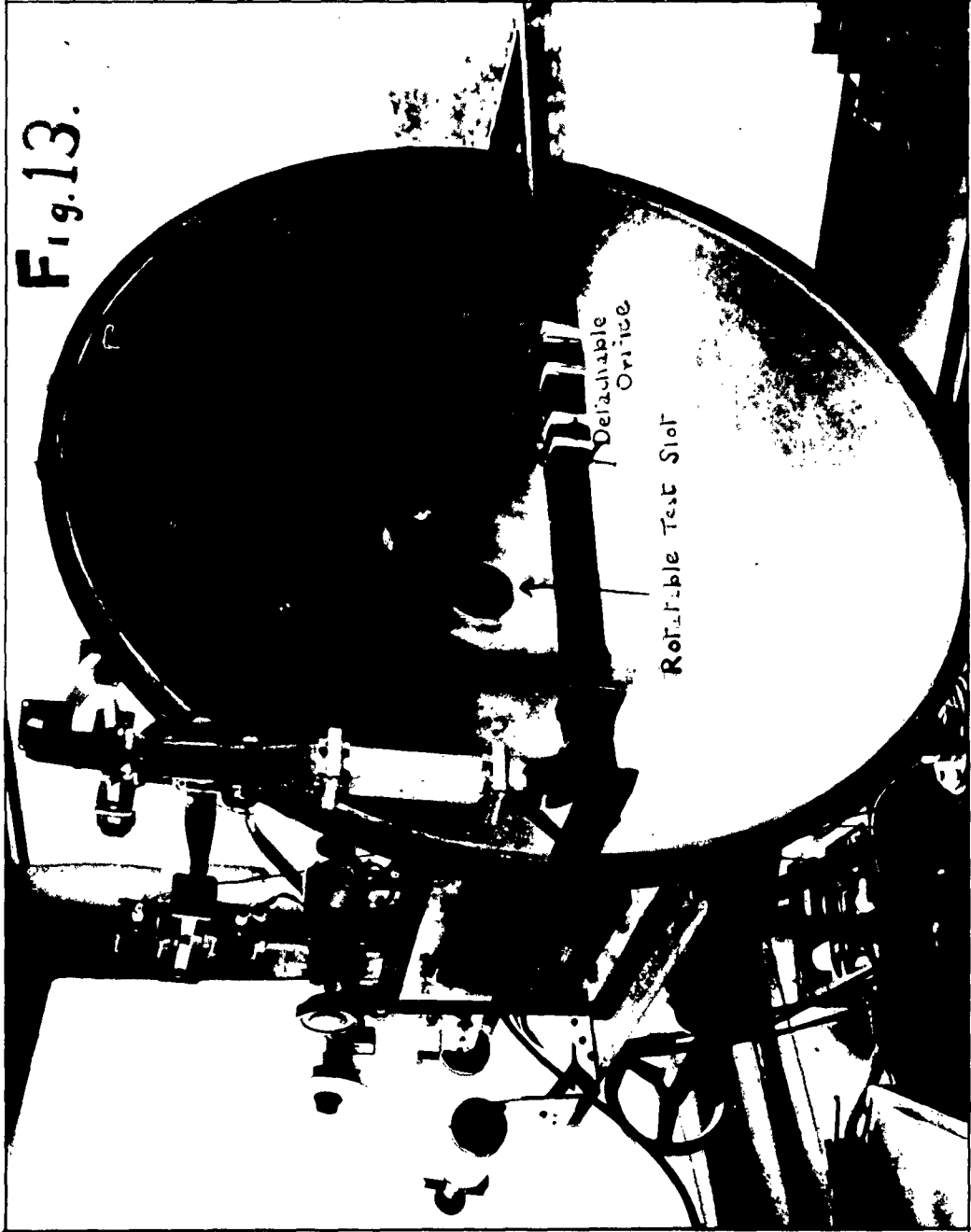
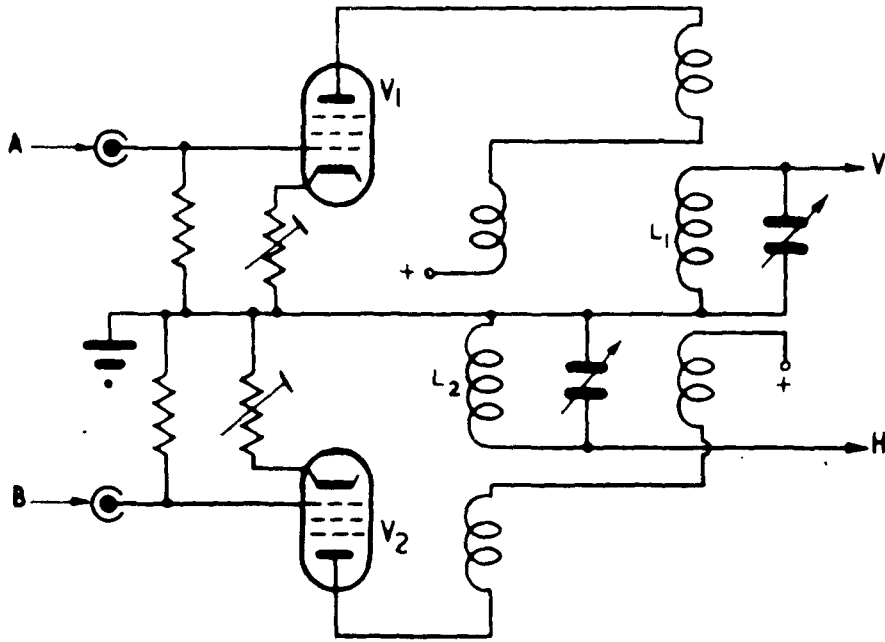


Fig. 9.

Fig. 13.



DRN.  
TRCOS. DDD  
CHKD  
APP. DDD



A AND B ASSUMED TO BE IN PHASE FOR VERTICAL POLARISATION  
A AND B ASSUMED TO BE OUT OF PHASE FOR HORIZONTAL POLARISATION.

FIG. 14.  
BASIC CIRCUIT OF PHASE BRIDGE.

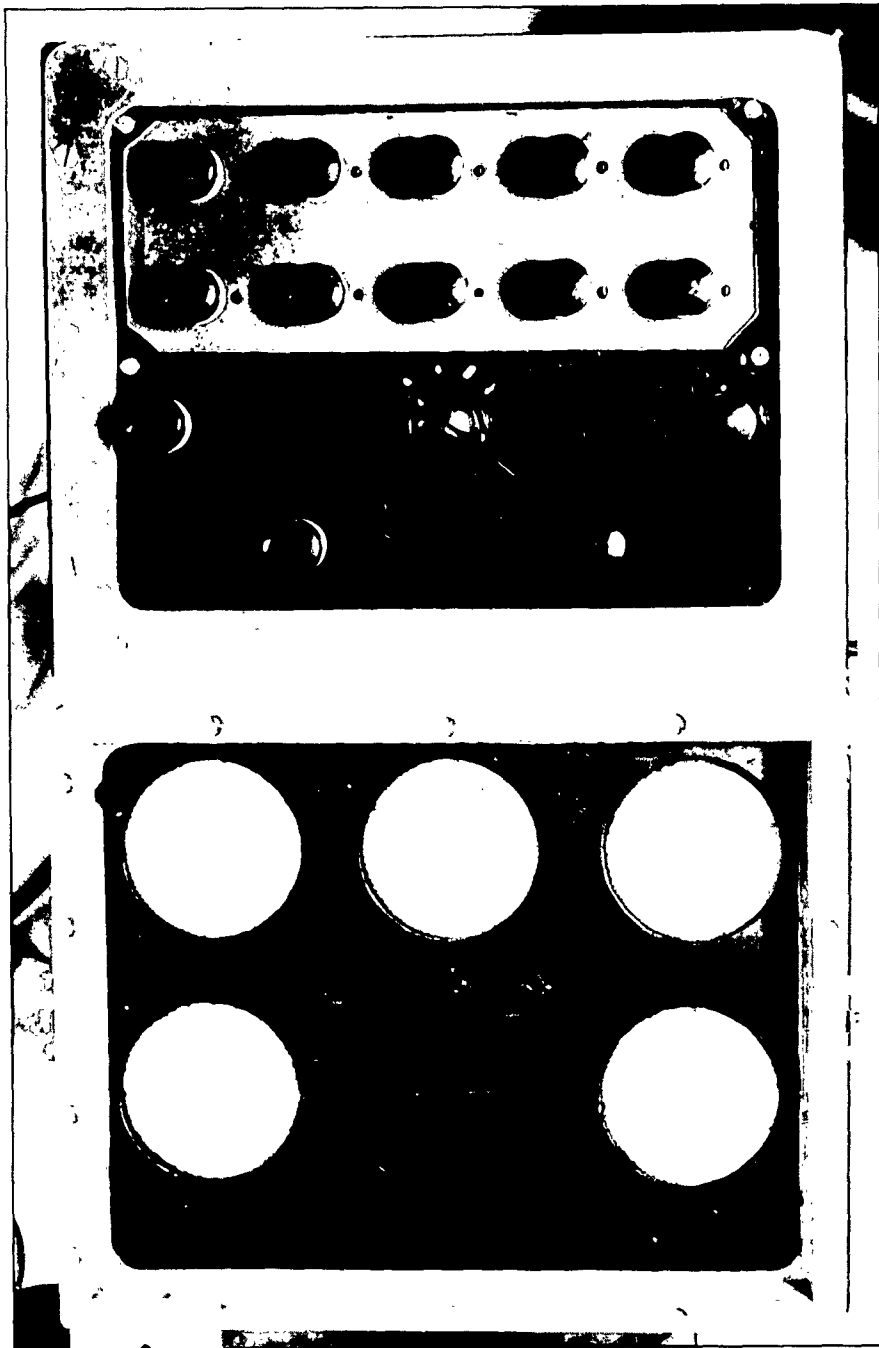


Fig 15.

DWN. PEAT  
TRCD.  
CHKD. *Col*  
APP. *Pat*

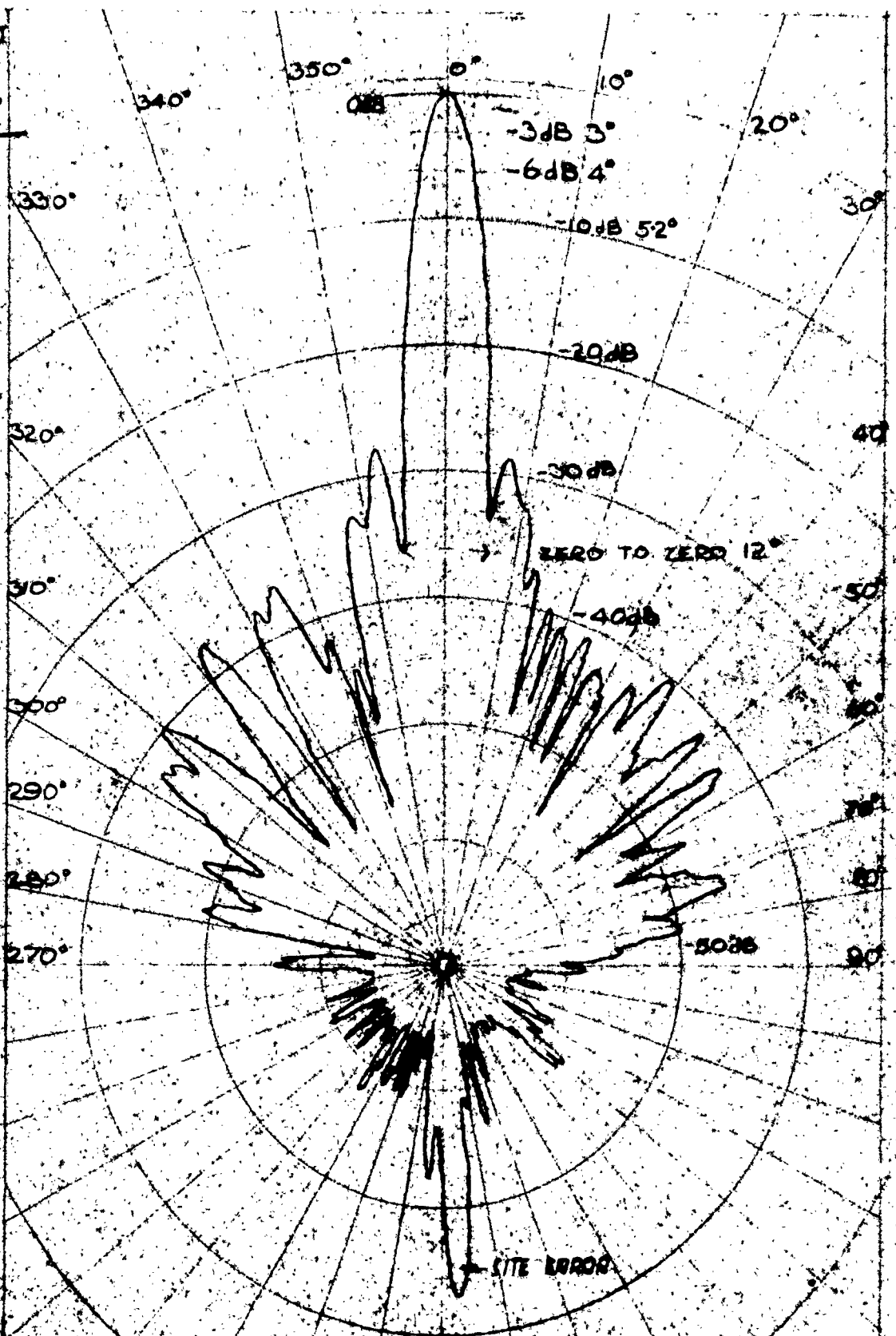


FIG. 16  
36" C.P. AERIAL  
AZIMUTH PATTERN 9375 MEG. C/S.

ISSUE  
A  
7-8-53  
T.R.E. M.O.S.  
R.T.R. 21/4158

DRN.  
TRCD  
CHKD  
APP.

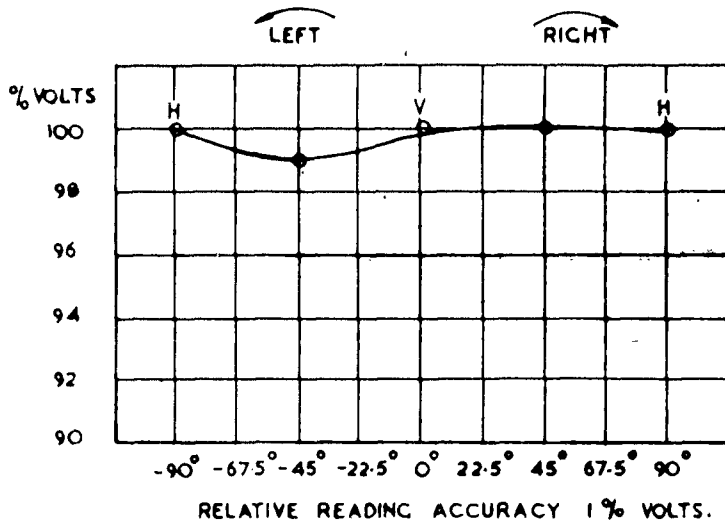


FIG. 17  
TRANSMITTER CIRCULARITY ON AXIS OF  
SECONDARY PATTERN AT 100 YARDS.

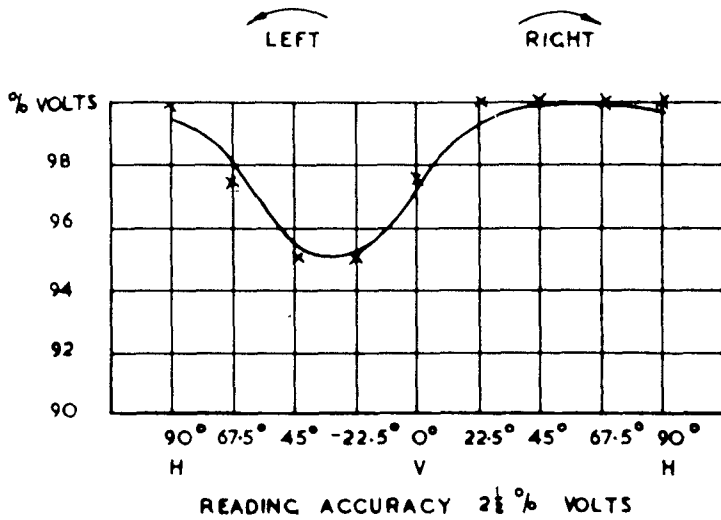


FIG. 18  
CIRCULARITY OF RECEIVER PRIMARY PATTERN  
(TEST SIGNAL RADIATED FROM SLOT IN MIRROR.)

DRN.  
TRCDJAMES  
CHKD  
APP. 8/10/50

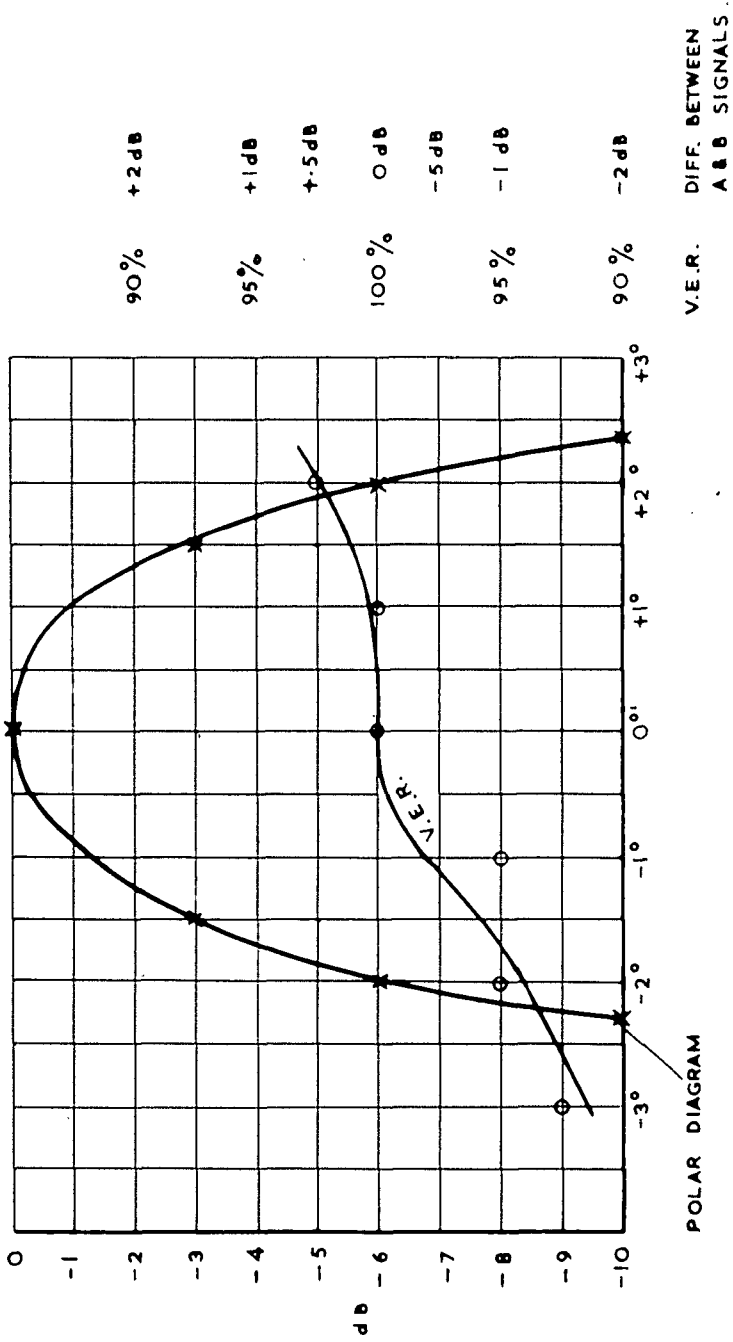
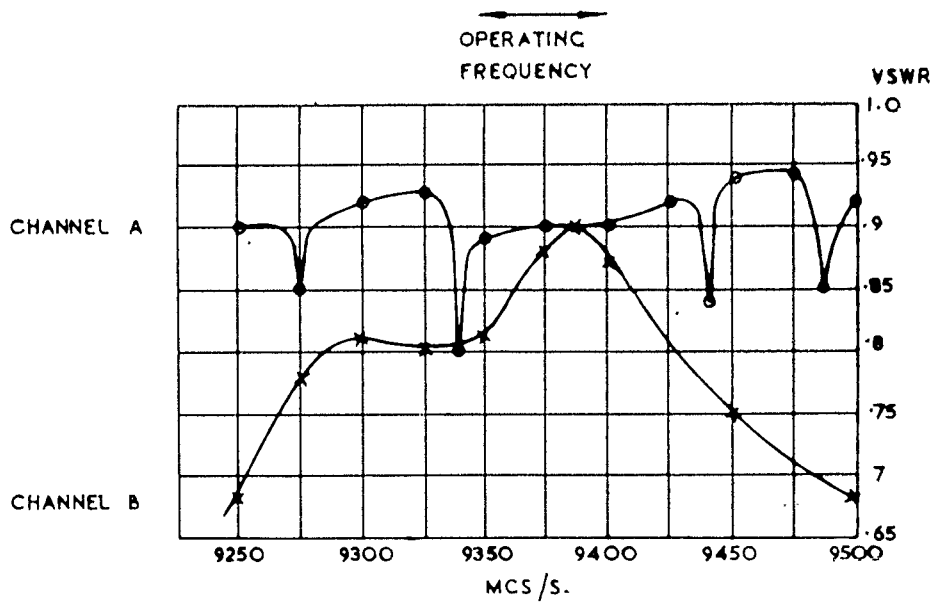


FIG. 19  
RELATIVE ELLIPTICITY AS FUNCTION  
OF BEAM AXIS

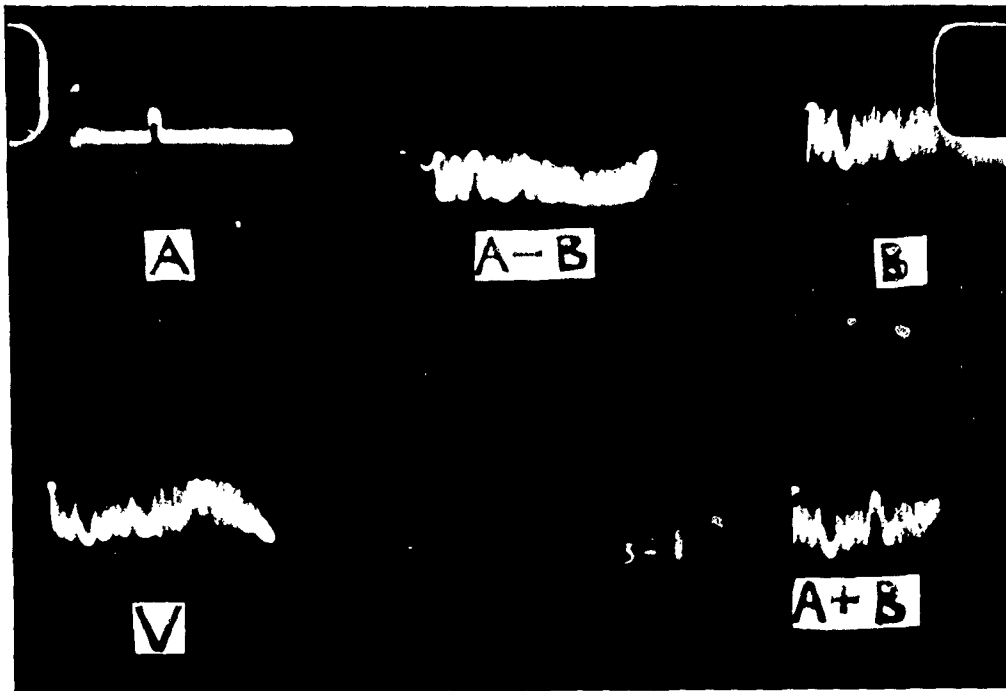
DRN  
 TRCDW  
 CHKD  
 APP. *[Signature]*



- NOTES (1) BOTH CURVES TAKEN FROM PLANE RESOLVER, LOOKING TOWARDS ORIFICE. ORIFICE WAS OPEN AND THERE WAS NO MIRROR
- (2) NARROW BANDWIDTH OF CHANNEL B IS DUE TO RESONANT SLOT IN PLANE RESOLVER.
- (3) NARROW RESONANCES WERE STILL PRESENT IN CHANNEL B CURVE, BUT TENDED TO BE SWAMPED BY EFFECT OF RESONANT SLOT.

FIG. 20  
 OVERALL VOLTAGE STANDING WAVE RATIO OF WAVEGUIDE SYSTEM





Rain Echoes using circular polarisation  
 Widespread gentle rain.  
 Note test pulse visible on Channel A+B.

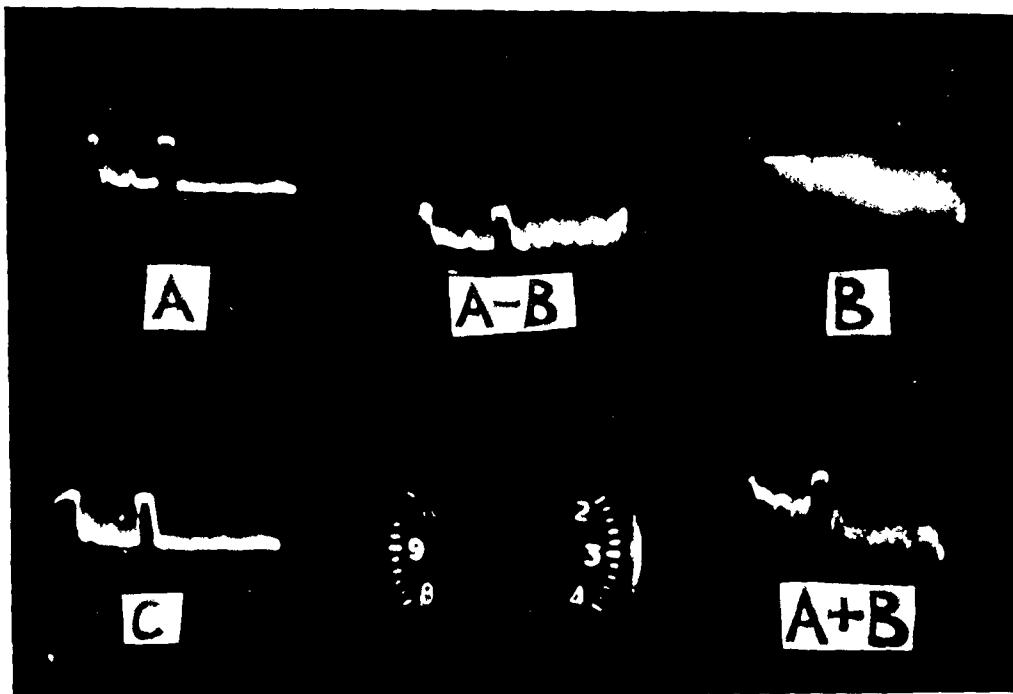
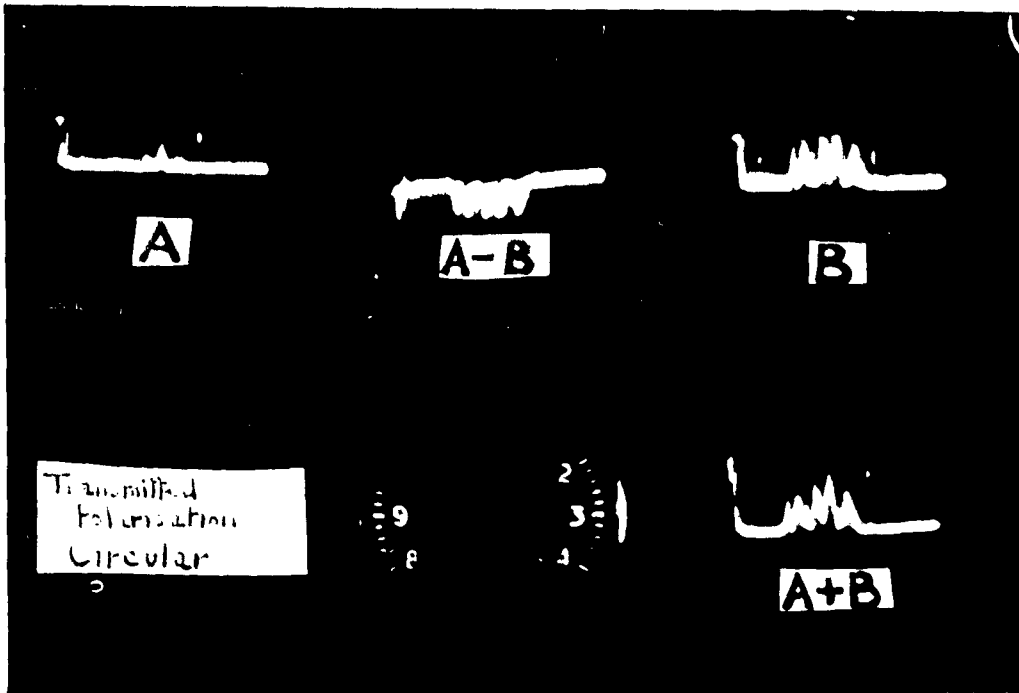


Fig 22 (a).!



Echoes from heavy showers (above) and thunder showers (below).  
 Bright-band echoes can be seen on A traces.  
 In lower picture anti-symmetrical aircraft echo can be seen near test pulse.

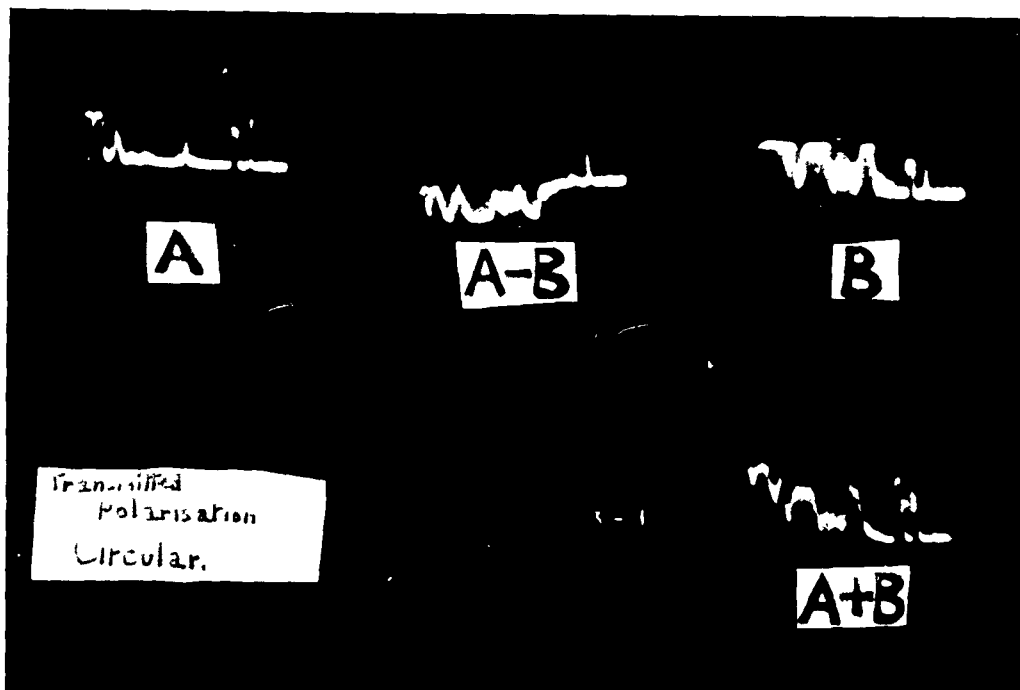


Fig 22 (b).

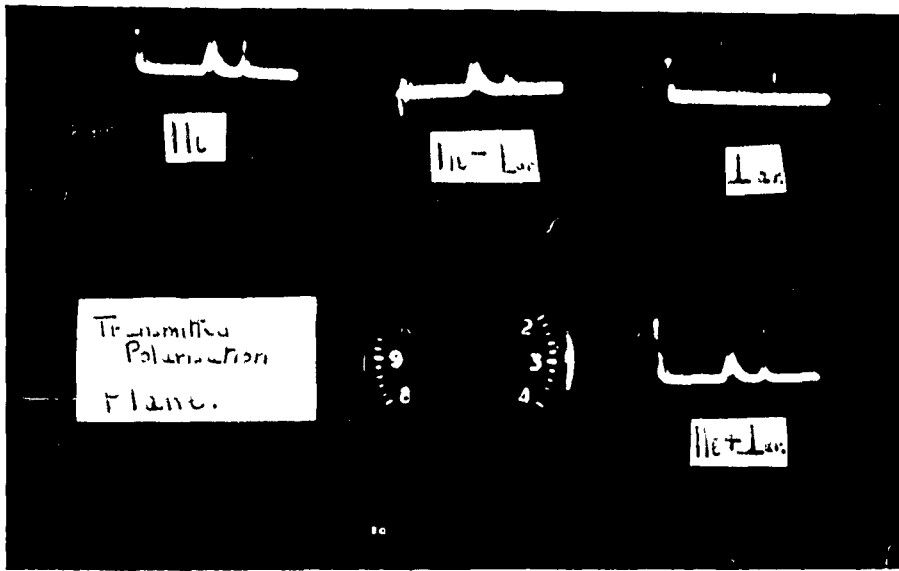


Fig 22(c). Rain Echoes, shewing Parallel and Cross-polarised component. Test pulse visible on  $H_c$  and  $L_{vc}$  traces.

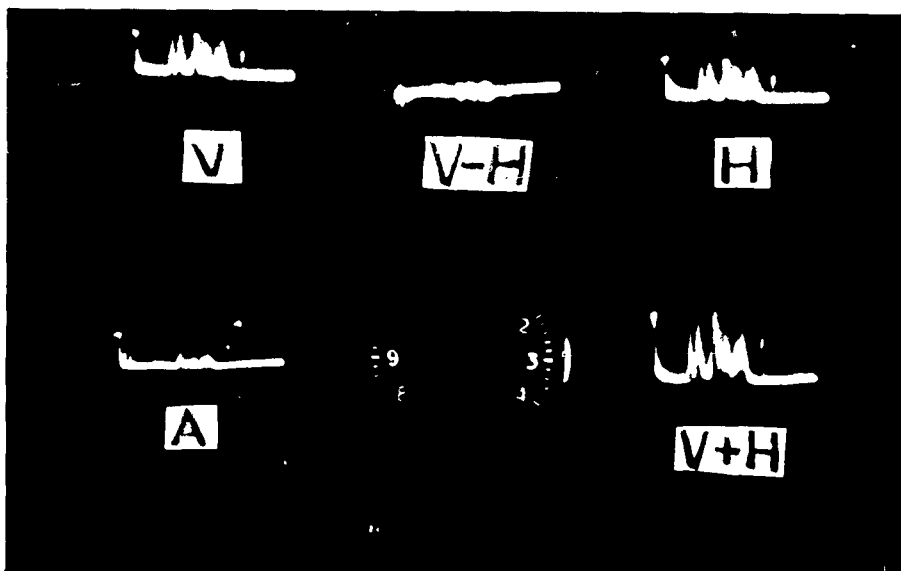


Fig 22(d). Rain Echoes, shewing Vertical and Horizontal components when illuminated with circular polarisation. Test Pulse balanced on  $V-H$ .

Fig 23(a)

WINDOW.

Receiver gains equal.

Test Pulse balanced  
on V-H.

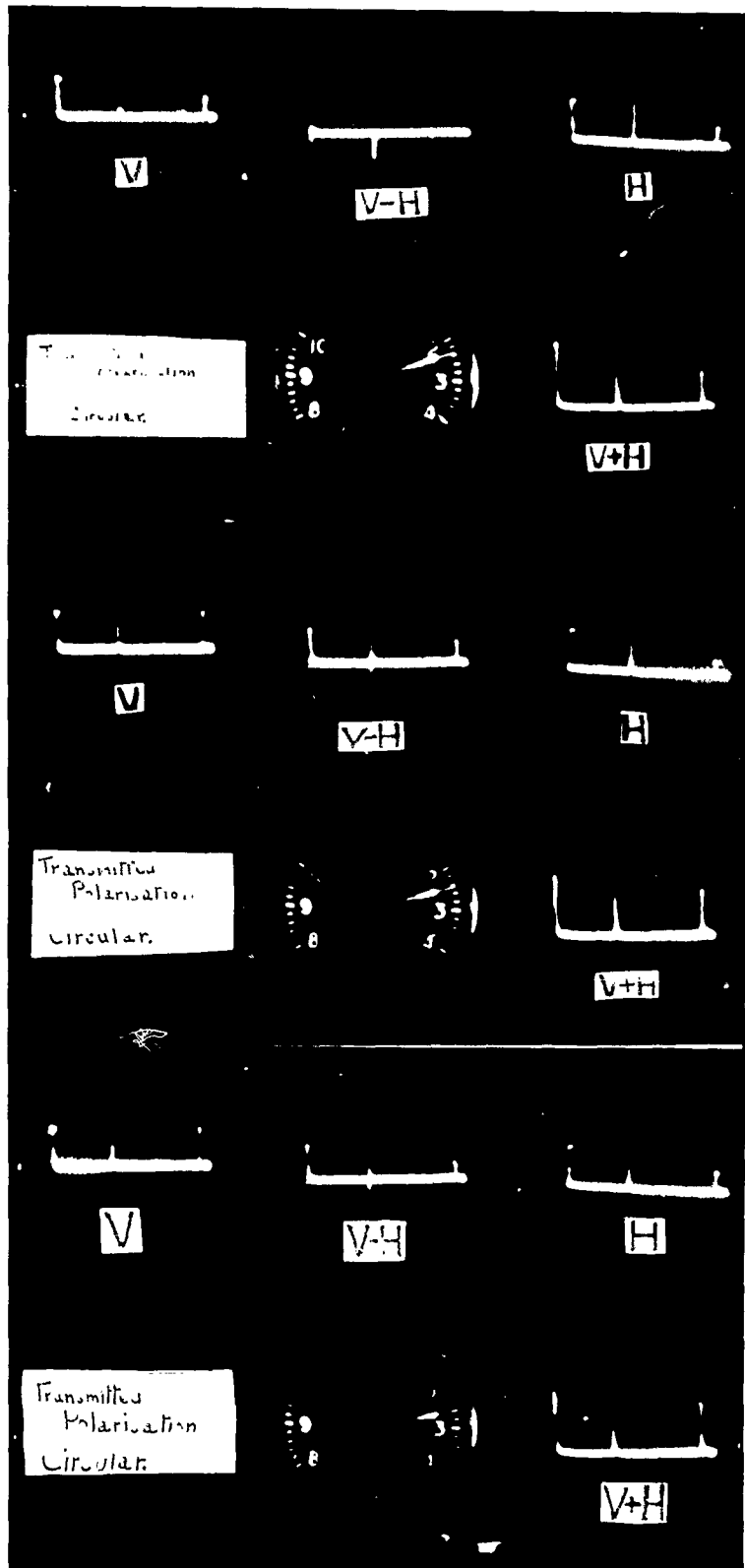


Fig 23(b)

Differential gain  
15 dB.

Test Pulse saturated  
in V.

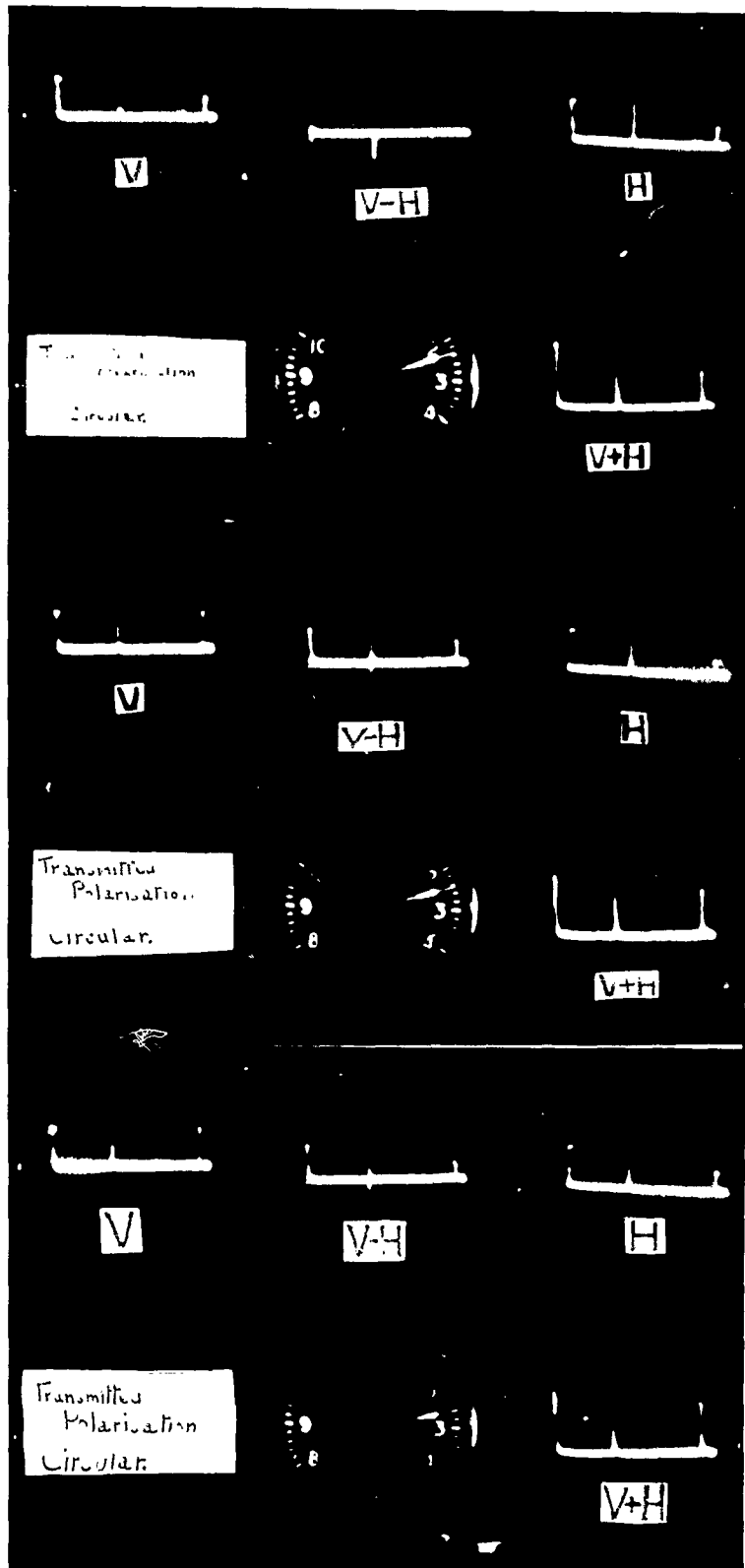
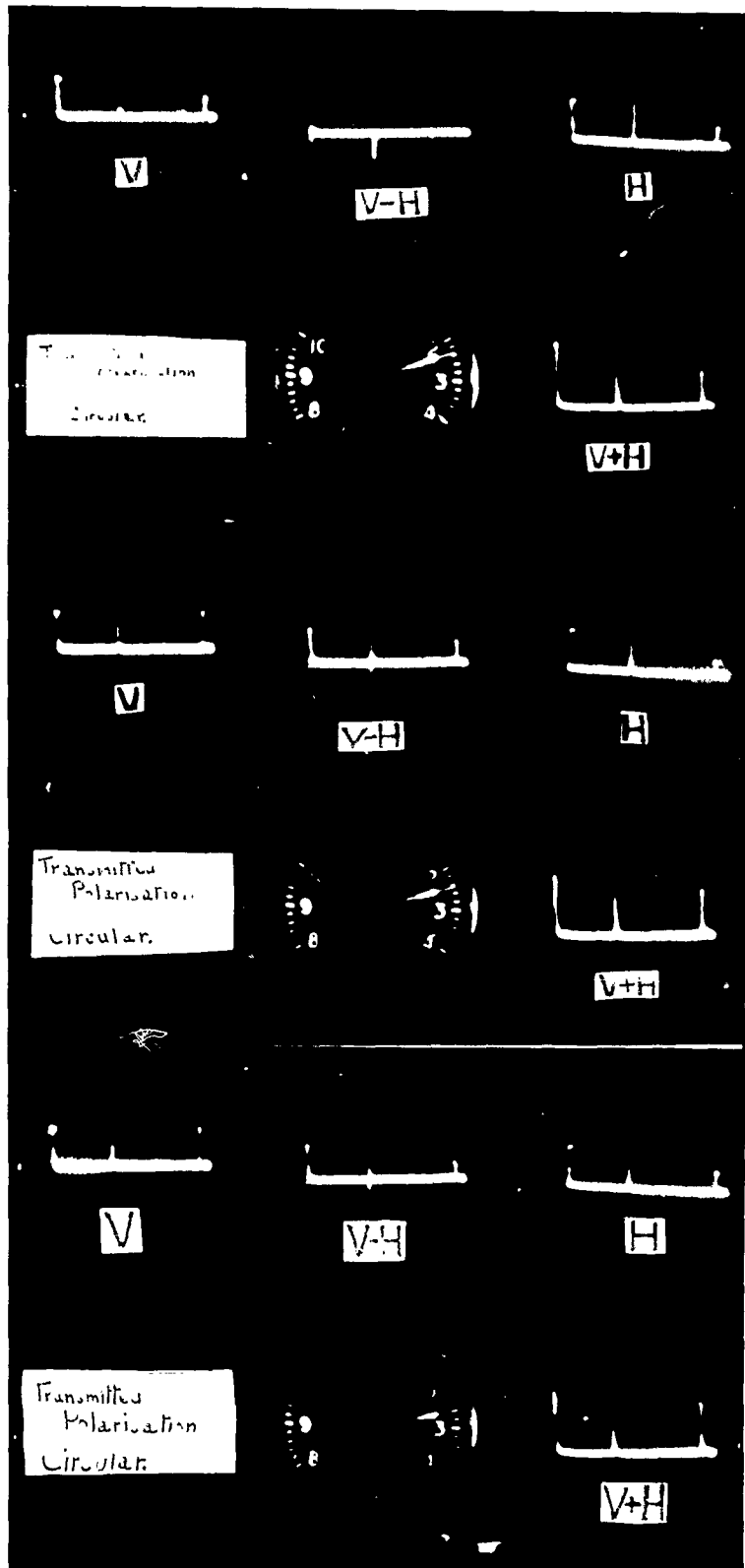


Fig 23(c)

Differential gain  
12 dB.

Test pulse  
saturating in V.



SECRET.

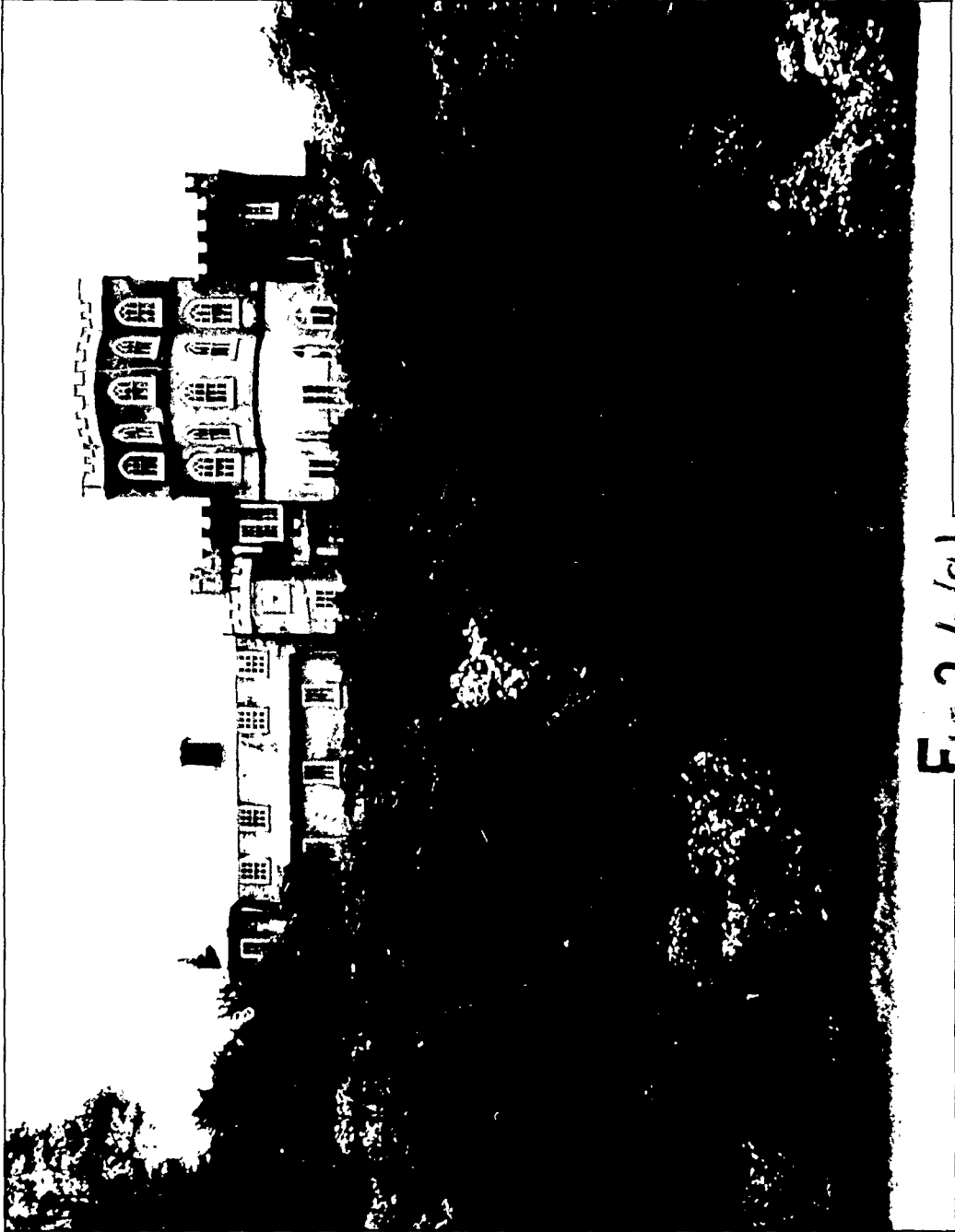
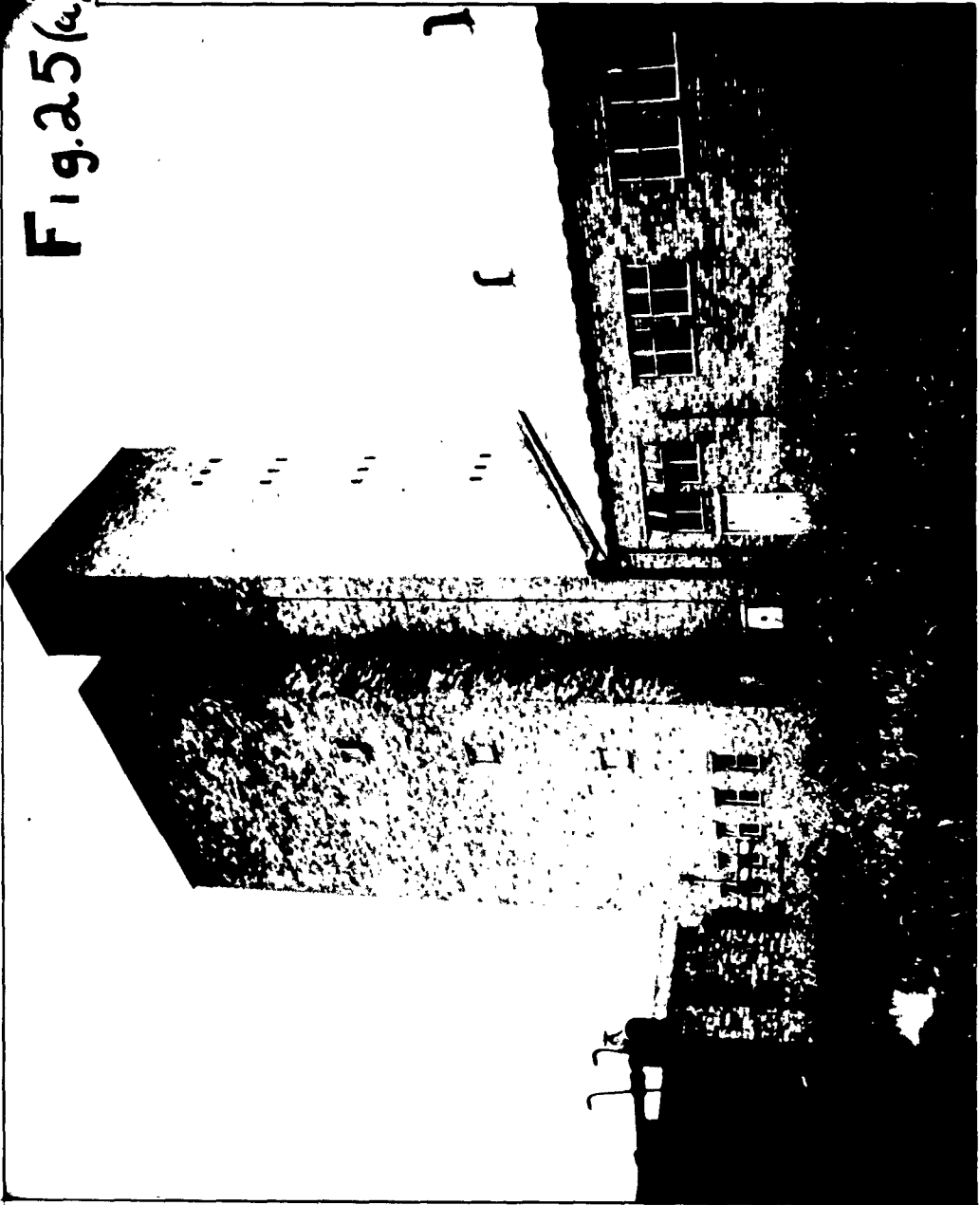


Fig 24(a).

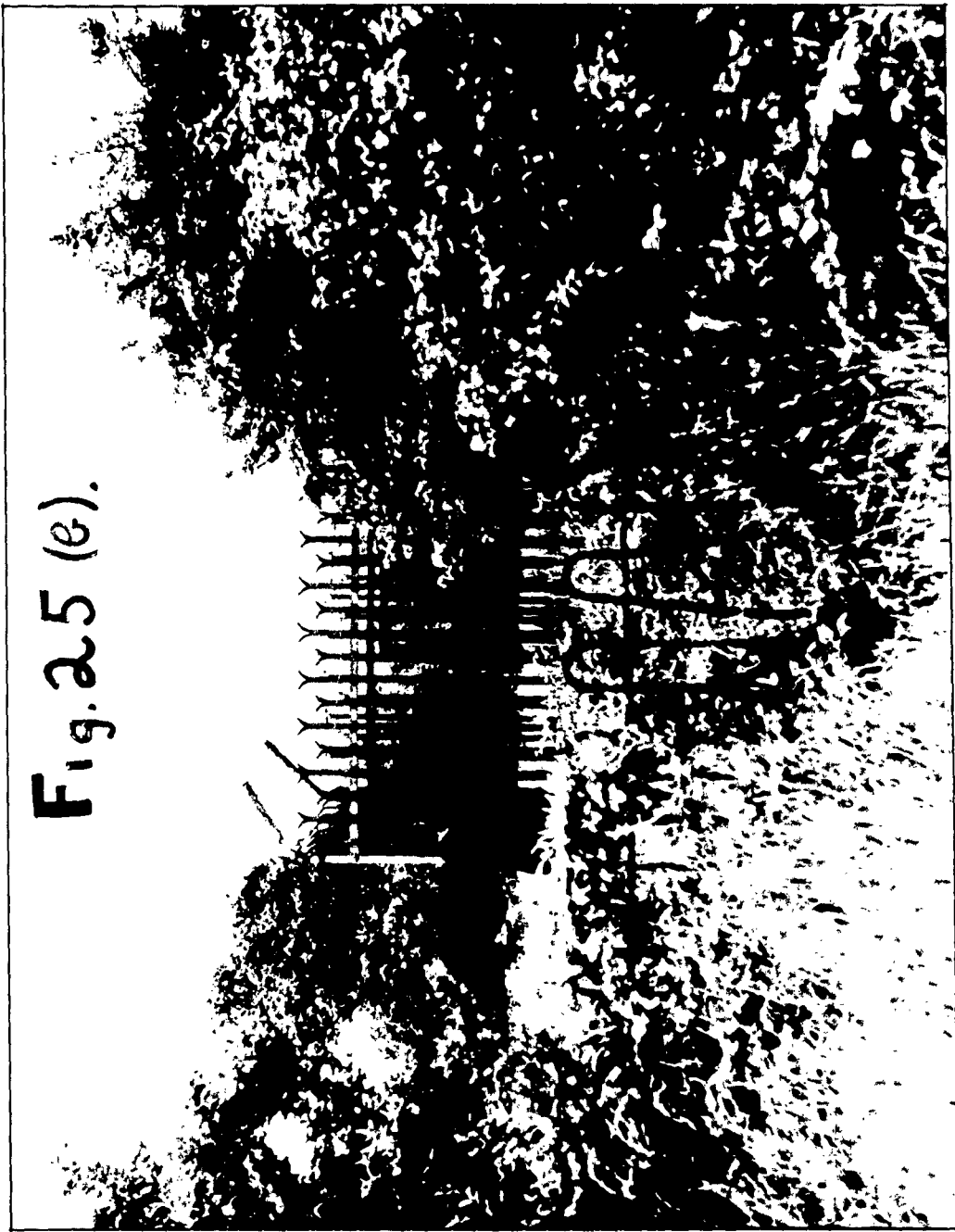
Fig. 24 (e).

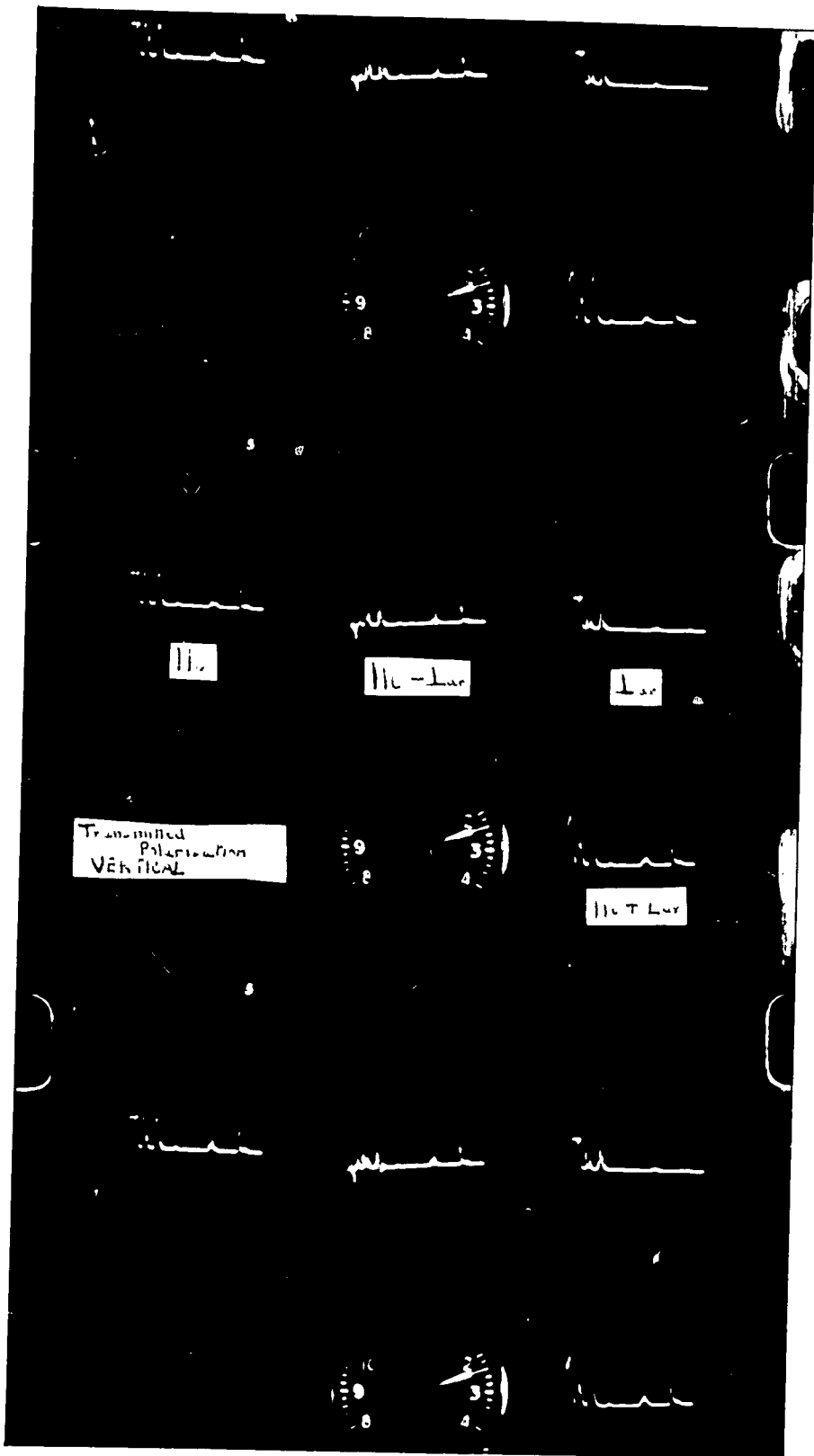


Fig. 25(a).



**Fig. 2.5 (e).**

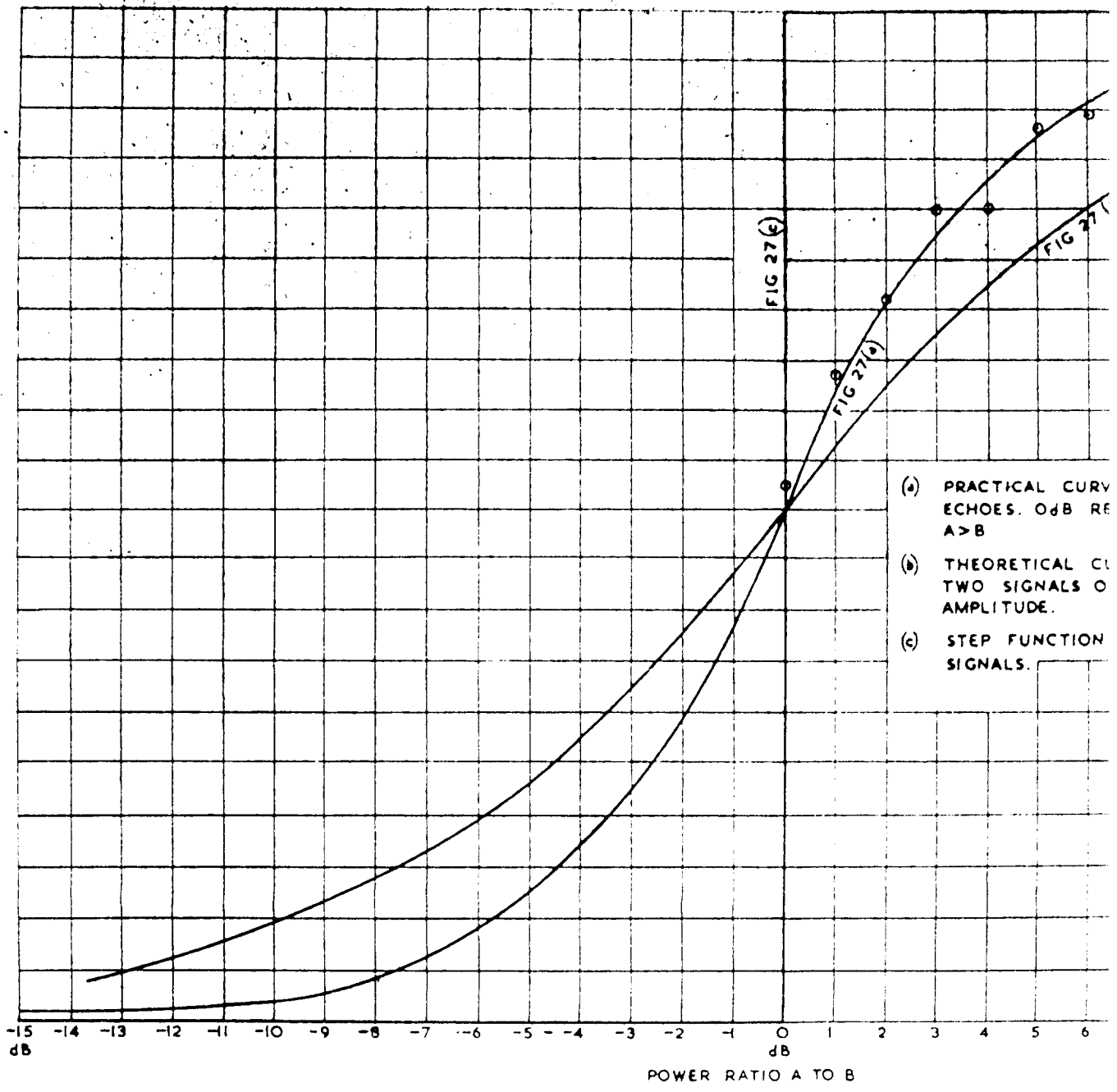




Parallel and Perpendicular components of Permanent Echoes illuminated with plane polarisation. Note very small cross polarised component from echo near end of trace. (actually Fig 24a).

Fig 26.

DOWN.  
 CHCK.  
 TRCD. S. ABBOT  
 APPD. ~~7/5~~  
 DATE.



- (a) PRACTICAL CURV ECHOES. 0dB RE A>B
- (b) THEORETICAL CU TWO SIGNALS O AMPLITUDE.
- (c) STEP FUNCTION SIGNALS.

FIG. 27  
 POWER RATIO A TO B

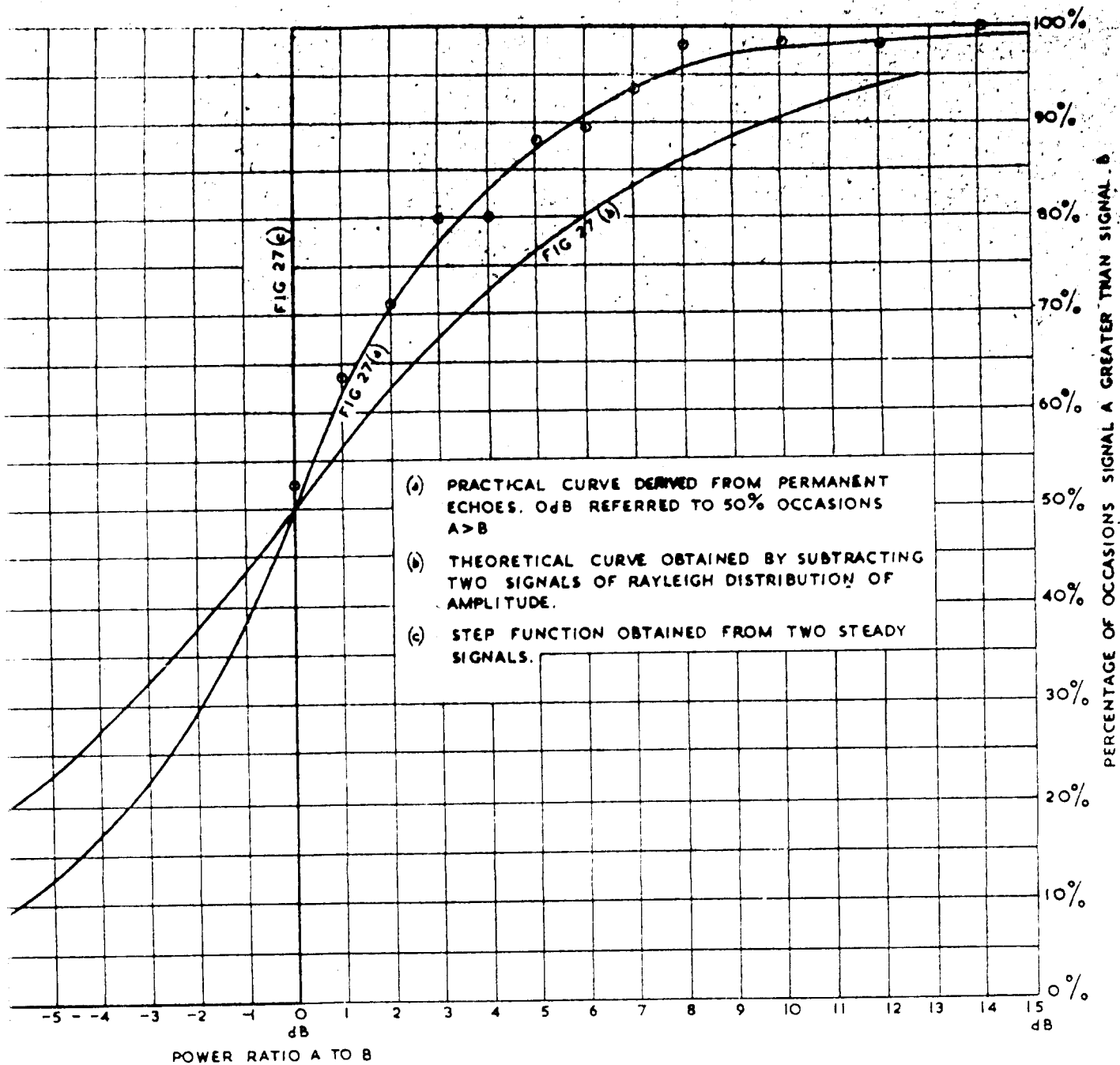


FIG. 27

POWER RATIO A TO B

SECRET

DOWN.  
 CHECK.  
 TRCD SABOT  
 APPD 1958  
 DATE.

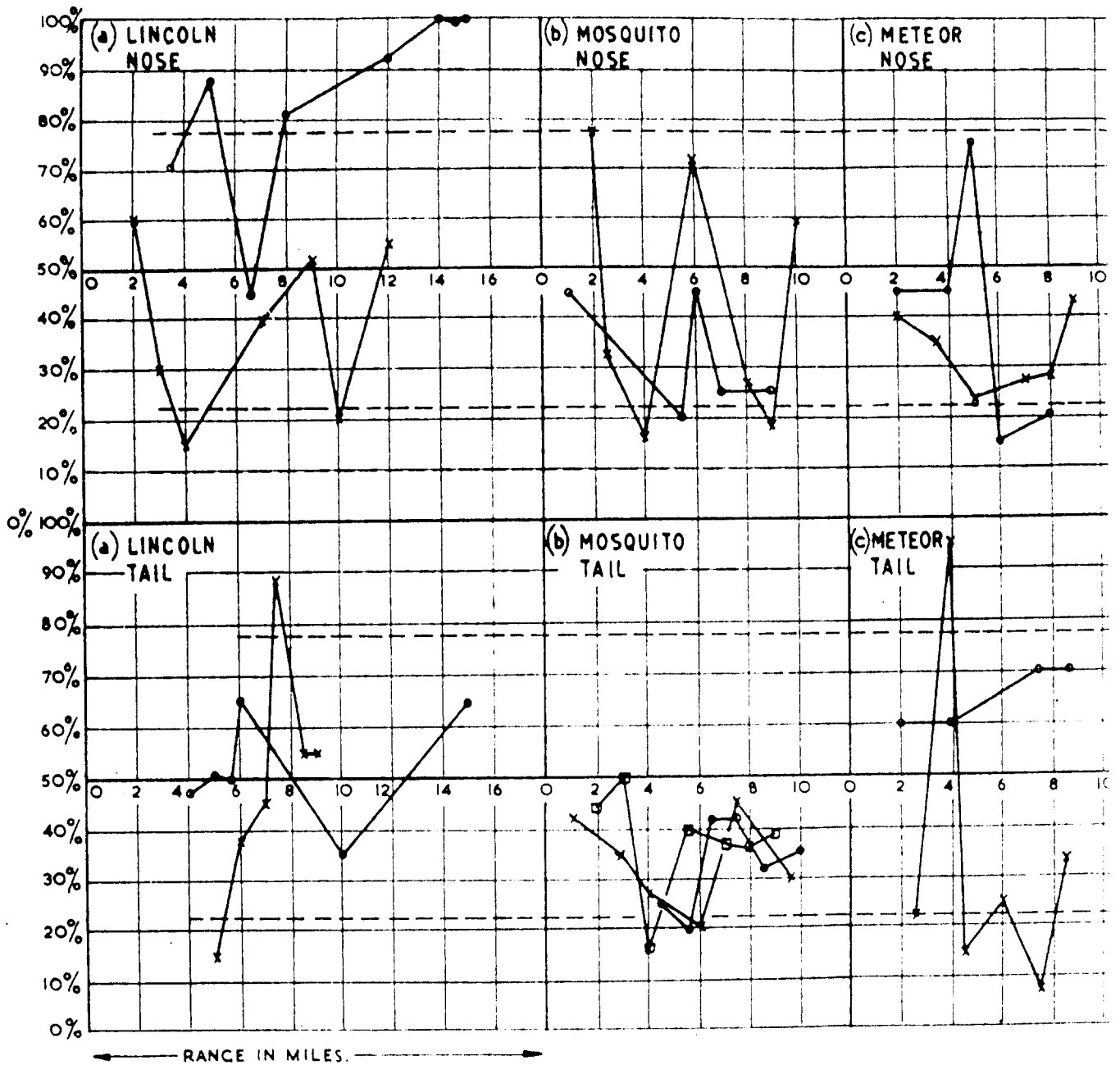


FIG. 28.

SAMPLE RESULTS FROM VARIOUS A  
 PERCENTAGE OF FRAMES A >

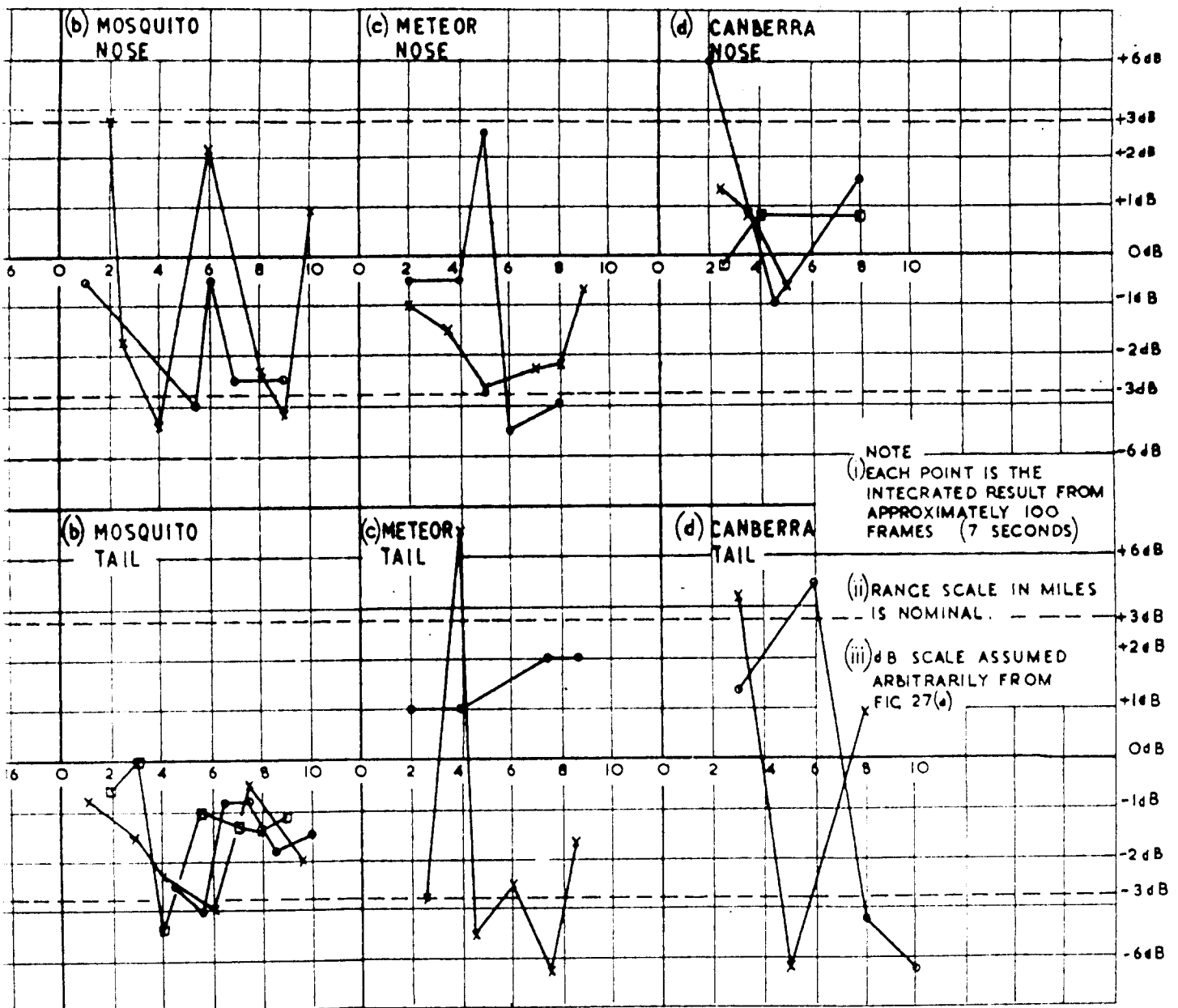


FIG. 28.

EXAMPLE RESULTS FROM VARIOUS AIRCRAFT.

PERCENTAGE OF FRAMES  $A > B$

SECRET

DRAWN  
 CHECKED  
 TPCD: SASS  
 APPD: [Signature]  
 DATE:

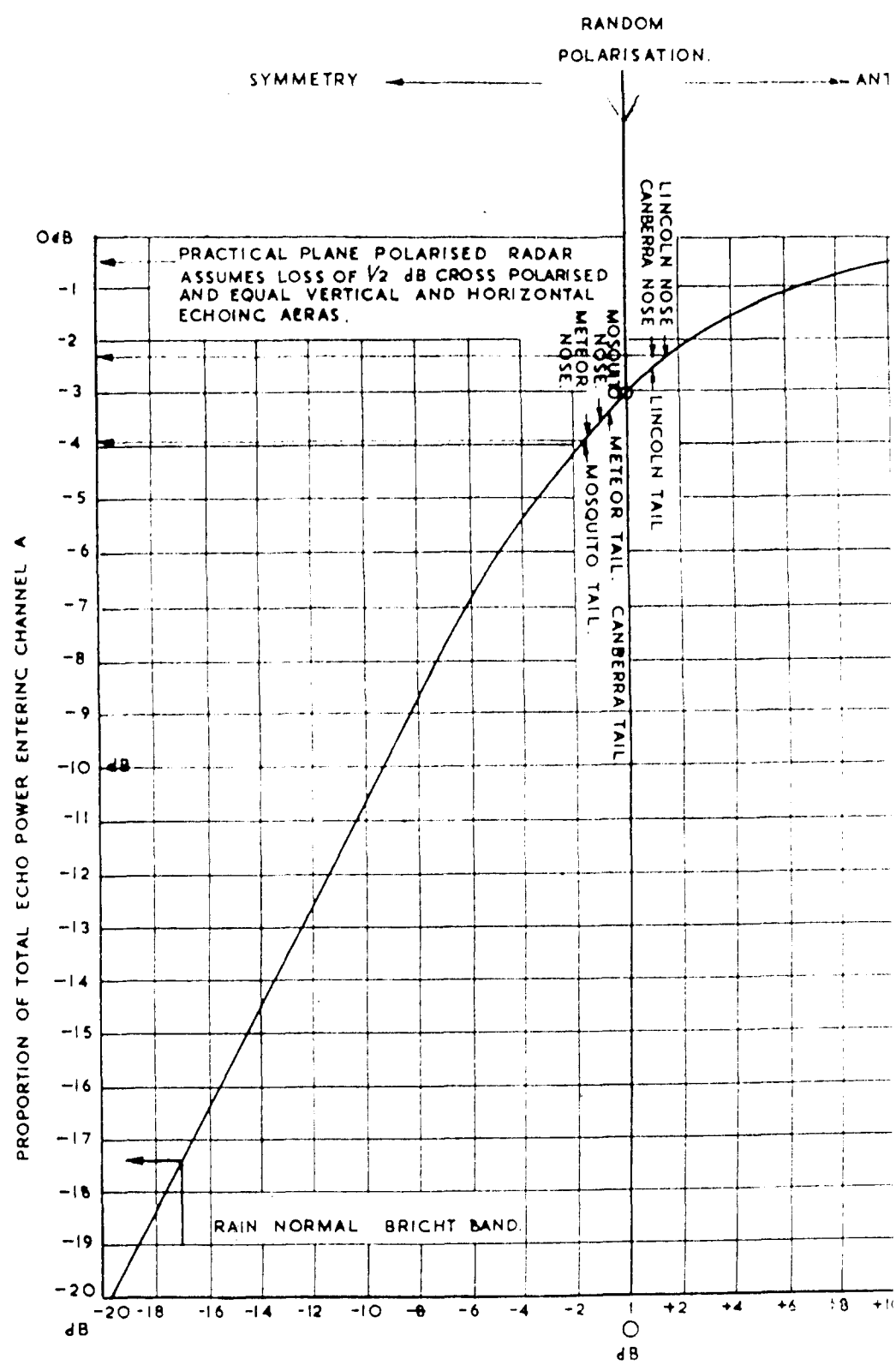


FIG. 29

RATIO OF CHANNEL A TO CHANNEL B SIGN

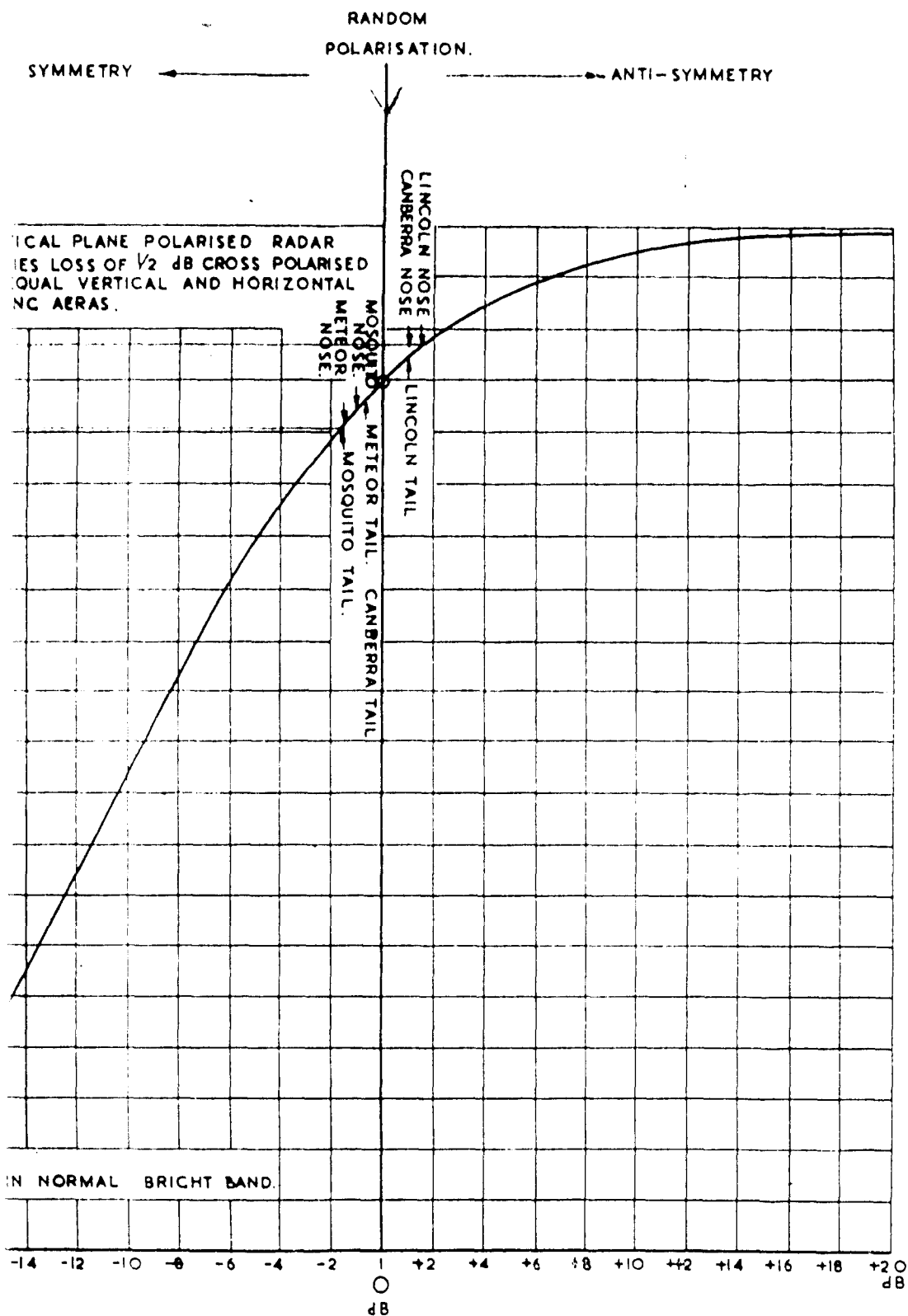


FIG. 29

CHANNEL A TO CHANNEL B SIGNAL STRENGTH.

SECRET

CHECK.  
TRCD SALL  
APPD.  
DATE.

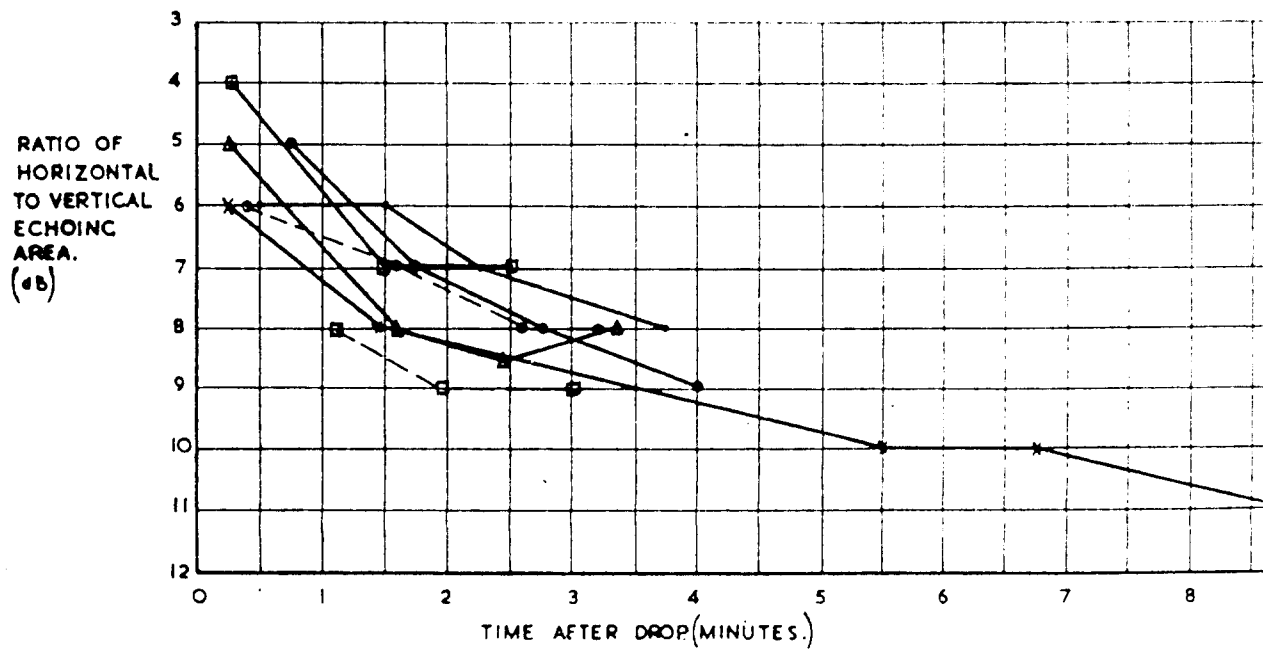
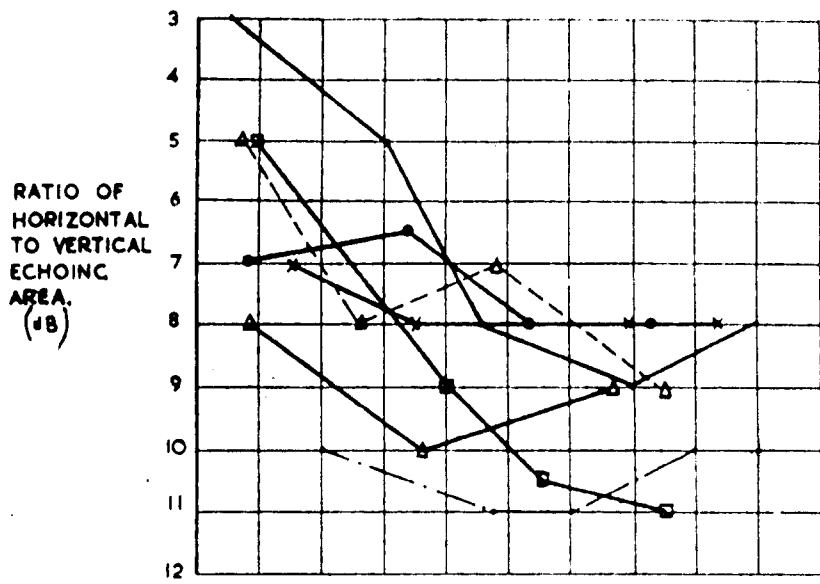


FIG. 30  
MEASUREMENTS ON TWO TYPES OF WIND  
OF IDENTICAL NOMINAL DIMENSIONS BUT  
METHODS OF PREPARATION. NOTE GREATER  
IN FIG. 30(b)

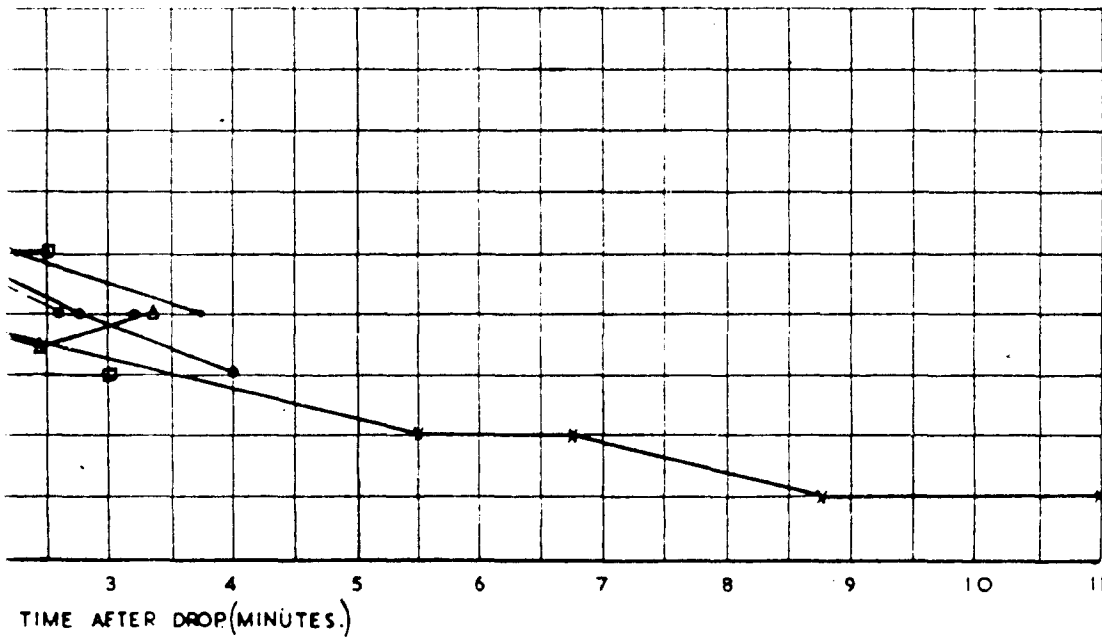
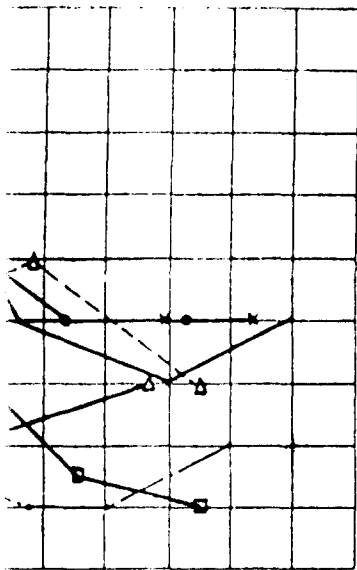


FIG. 30

EXPERIMENTS ON TWO TYPES OF WINDOW JAMMING  
 WITH IDENTICAL NOMINAL DIMENSIONS BUT DIFFERENT  
 METHODS OF PREPARATION. NOTE GREATER CONSISTENCY  
 IN FIG. 30(b)

SECRET.



*Information Centre  
Knowledge Services*  
**[dstl]** *Porton Down,  
Salisbury  
Wiltshire  
SP4 0JQ  
22060-6218  
Tel: 01980-613753  
Fax 01980-613970*

Defense Technical Information Center (DTIC)  
8725 John J. Kingman Road, Suit 0944  
Fort Belvoir, VA 22060-6218  
U.S.A.

AD#: AD020254

Date of Search: 16 September 2008

Record Summary: AVIA 26/1689

Title: The Polarisation Characteristics of Certain Radar Echoes on X-Band  
Availability Open Document, Open Description, Normal Closure before FOI Act: 30 years  
Former reference (Department) 196  
Held by The National Archives, Kew

This document is now available at the National Archives, Kew, Surrey, United Kingdom.

DTIC has checked the National Archives Catalogue website (<http://www.nationalarchives.gov.uk>) and found the document is available and releasable to the public.

Access to UK public records is governed by statute, namely the Public Records Act, 1958, and the Public Records Act, 1967.

The document has been released under the 30 year rule.

(The vast majority of records selected for permanent preservation are made available to the public when they are 30 years old. This is commonly referred to as the 30 year rule and was established by the Public Records Act of 1967).

**This document may be treated as UNLIMITED.**