

UNCLASSIFIED

AD NUMBER

AD020267

CLASSIFICATION CHANGES

TO: unclassified

FROM: restricted

LIMITATION CHANGES

TO:
Approved for public release, distribution
unlimited

FROM:
Controlling Organization: British Embassy,
3100 Massachusetts Avenue, NW, Washington,
DC 20008.

AUTHORITY

DSTL, AVIA 18/4580, 29 Jul 2008; DSTL,
AVIA 18/4580, 29 Jul 2008

THIS PAGE IS UNCLASSIFIED

Armed Services Technical Information Agency

AD

20267

NOTICE: WHEN GOVERNMENT OR OTHER DRAWINGS, SPECIFICATIONS OR OTHER DATA ARE USED FOR ANY PURPOSE OTHER THAN IN CONNECTION WITH A DEFINITELY RELATED GOVERNMENT PROCUREMENT OPERATION, THE U. S. GOVERNMENT THEREBY INCURS NO RESPONSIBILITY, NOR ANY OBLIGATION WHATSOEVER; AND THE FACT THAT THE GOVERNMENT MAY HAVE FORMULATED, FURNISHED, OR IN ANY WAY SUPPLIED THE SAID DRAWINGS, SPECIFICATIONS, OR OTHER DATA IS NOT TO BE REGARDED BY IMPLICATION OR OTHERWISE AS IN ANY MANNER LICENSING THE HOLDER OR ANY OTHER PERSON OR CORPORATION, OR CONVEYING ANY RIGHTS OR PERMISSION TO MANUFACTURE, USE OR SELL ANY PATENTED INVENTION THAT MAY IN ANY WAY BE RELATED THERETO.

Reproduced by

DOCUMENT SERVICE CENTER

BUILDING DAYTON, 2, OHIO

RESTRICTED

The following ESPIONAGE NOTICE can be disregarded unless this document is plainly marked RESTRICTED, CONFIDENTIAL, or SECRET.

NOTICE: THIS DOCUMENT CONTAINS INFORMATION AFFECTING THE NATIONAL DEFENSE OF THE UNITED STATES WITHIN THE MEANING OF THE ESPIONAGE LAWS, TITLE 18, U.S.C., SECTIONS 793 and 794. THE TRANSMISSION OR THE REVELATION OF ITS CONTENTS IN ANY MANNER TO AN UNAUTHORIZED PERSON IS PROHIBITED BY LAW.

THE RECIPIENT IS WARNED THAT INFORMATION CONTAINED IN THIS DOCUMENT MAY BE SUBJECT TO PRIVATELY-OWNED RIGHTS.

22nd Part of AAEE/861/1



20267
ASTIA FILE COPY

MINISTRY OF SUPPLY

**AEROPLANE AND ARMAMENT
EXPERIMENTAL ESTABLISHMENT**

BOSCOMBE DOWN

CANERRA MK.2 WD. 954
(2 x AVON MK.1)

CABIN TEMPERATURE AND COLD AIR UNIT TRIALS
A. & A.E.E., AT KHARTOUM AND AT ADEN

CONDITIONS OF RELEASE

1. THIS INFORMATION IS DISCLOSED ONLY FOR OFFICIAL USE BY THE RECIPIENT GOVERNMENT AND SUCH OF ITS CONTRACTORS UNDER SEAL OF SECURITY, AS MAY BE ENGAGED ON A DEFENCE PROJECT. DISCLOSURE TO ANY OTHER GOVERNMENT OR RELEASE TO THE PRESS OR IN ANY OTHER WAY WOULD BE A BREACH OF THESE CONDITIONS.

2. THE INFORMATION SHOULD BE SAFEGUARDED UNDER RULES DESIGNED TO GIVE THE SAME STANDARD OF SECURITY AS THAT MAINTAINED BY HIS MAJESTY'S GOVERNMENT IN THE UNITED KINGDOM.

ATTENTION IS CALLED TO THE PENALTIES ATTACHING TO ANY INFRINGEMENT OF THE OFFICIAL SECRETS ACT.

THIS DOCUMENT IS THE PROPERTY OF H.M. GOVERNMENT.

It is intended for the use of the recipient only, and for communication to such officers under him as may require to be acquainted with the contents of the report in the course of their duties. The officers exercising this power of communication will be held responsible that such information is imparted with due caution and reserve.

Any person other than the authorised holder, upon obtaining possession of this document, by finding or otherwise, should forward it, together with his name and address, in a closed envelope to :-

THE SECRETARY, MINISTRY OF SUPPLY,
T.P.A.3/T.I.B., LEYSDOWN ROAD, MOTTINGHAM, S.E.9.

Letter postage need not be prepaid : other postage will be refunded.

All persons are hereby warned that the unauthorised retention or destruction of this document is an offence against the Official Secrets Acts, 1911-1939.

ENCLOSURE 3 TO ASTIA 26453

AEROPLANE AND ARMAMENT EXPERIMENTAL ESTABLISHMENT
BOSCOMBE DOWN

29 JUL 1953

Canberra Mk.2. WD. 954
(2 x Avon Mk.1)Cabin Temperature and Cold Air Unit Trials at
A. & A.E.E., at Khartoum and at AdenA. & A.E.E. Ref: 6231/T/2/WPW
Period of Test : July - August 1952

Report No.		Progress of issue of Report	
		Title	
17th Part A.AEE/861/1	VX.165	Longitudinal Stability and Manoeuvrability Tests.	
18th - do -		Test Fuselage Ground Hood and Hatch Jettison Trials.	
19th - do -	VX.169	Further Measurements of Vibration with Bomb Doors open.	
20th - do -	VX.169	Measurement of Vibration of Aircraft and Bombsight at Bomb Aimer's Station with Bomb Doors open.	
21st - do -	VX.169	Acceptance Trials of Bombing and Pyrotechnic Installation.	

Summary

Measurements of cabin temperatures on the ground, with and without the use of a Coolair Minor and sun awning were made on a Canberra aircraft in tropical conditions at Khartoum.

It is considered that the sun awning alone is sufficient to keep cabin temperatures at a comfortable level and that the additional expense and complication of a Coolair Minor is unwarranted except for servicing purposes.

Tests were also made in the air under both temperate and tropical conditions to assess the degree of cooling afforded by an A.C.R.E.9 Cold Air Unit.

At low altitudes the cabin becomes uncomfortably hot if the C.A.U. is not used and although the actual temperature drop afforded by use of the unit is small, a marked increase in comfort is noticeable if lightweight clothing is worn.

Modifications to increase and diffuse the mass flow at the cabin inlets are recommended, particular emphasis being made on the desirability of improved cooling during taxiing when the crew are likely to be wearing heavy clothing suitable for high altitude flying.

This Report is issued with the authority of



Air Commodore
Commanding A. & A.E.E.

List of Contents

	<u>Page</u>
1. Introduction	4
2. Description of Cabin Air Conditioning System	4
3. Description of Instrumentation	5
4. Description of Trials.	6
5. Results of Trials	8
6. Discussion on Cabin Temperature Results	8
7. Discussion on Ground Temperature and cooling results	11
8. Discussion on canopy misting test	13
9. Discussion on water separator trials	13
10. Discussion on cold air system	13
11. Defects experienced during trials of cold air system	14
12. Conclusions and recommendations	14
13. Further developments	15

List of Illustrations

	<u>Figure</u>
Diagrammatic representation of cabin heating and cooling system	1
Installation of cabin heating and cooling system	2
Arrangement of C.A.U. installation in port wing	3
A.C.R.E. 9 Cold Air Unit	4
View of secondary cooler intake	5
View of primary cooler intake	6
Arrangement of ducting and louvres for cabin conditioning	7
View of louvre in pilots clock position	8
View of louvre above bomb aimers tunnel	9
View of louvres at navigators table	10
View of diffuser at port side of pilots seat	11
View of louvres on stbd. side of cabin	12
View of fishtail forward of rudder bar	13
C.A.U. auto-observer instrumentation	14
Method of introducing thermometer pencil in pipes	15
Method of introducing pressure tapping in pipes	16
200 knot trial at Boscombe Down	17
325 knot trial at Boscombe Down	18
485 knot trial at Boscombe Down	19
Cabin temperatures - temperate summer - 200 knots	20
Cabin temperatures - temperate summer - 325 knots	21
Cabin temperature - temperate summer - 485 knots	22
Average cabin temperatures - temperate summer	23
Cabin temperatures in transit - U.K. to Khartoum	24
Cabin temperatures in transit - U.K. to Castel Benito	25
Cabin Temperatures in transit - Castel Benito to Khartoum	26
200 knot trial - Khartoum - Cold air ON	27
200 knot trial - Khartoum - Ram air ONLY	28
325 knot trial - Khartoum - Cold air ON	29
325 knot trial - Khartoum - Ram air ONLY	30
Cabin temperatures - tropical summer - 200 knots	31
Cabin temperatures - tropical summer - 200 knots	32
Cabin temperatures - tropical summer 325 knots	33
Cabin temperatures - tropical summer - 325 knots	34
Average cabin temps - tropical summer - 200 knots	35
Average cabin temps - tropical summer - 325 knots	36
200 knot night trial - Khartoum - Cold air ON	37
200 knot Night trial - Khartoum - Ram air ONLY	38
Cabin temps - tropical summer night - 200 knots	39
Cabin temps - tropical summer night - 200 knots	40
Average cabin temps - tropical summer night - 200 knots	41
Average cabin temperatures - tropical summer	42
View of protective awning in situ	43
Extent of paper covering during ground trial	44
View of diffuser nozzle for cold air minor	45
Arrangement during ground cooling trials	46

	<u>Figure</u>
Godfrey Air Conditioning Trolley	47
Ground temperature results - no protection	48
Ground temperature results - with awning	49
Ground temperature results - with white paper	50
Ground temperature trials - average temperatures	51
Engine bay temperatures during ground running	52
Engine bay temperatures whilst parked in sun	53
Stabilised temperatures showing distribution of cooling	54
Engine compressor pressures during ground running	55
Variations in mass flow with engine delivery pressure	56
Temperature variations in cold air system	57
Pressure variations in cold air system	58
Variation in pressure ratio with engine delivery pressure	59
Variation in mass flow with I.A.S.	60

/1. Introduction.....

1. Introduction

1.1 Cabin temperature tests were made on Canberra aircraft WD.954 under both temperate and tropical conditions to assess the degree of cooling afforded by an A.C.R.E.9 Cold Air Unit.

1.2 The tests were repeated in different ambient air temperatures at different altitudes to collect evidence for determining the factor to be used for correcting cabin temperatures to tropical conditions. The conclusions drawn from these results will be the subject of a separate report.

1.3 Trials were made at Aden under conditions of high temperature and humidity during flight to ascertain the need for and effectiveness of the water separator in the Cold Air System.

1.4 Trials were made on the ground to determine the cabin temperatures reached when the aircraft was parked in the sun and a comparison was drawn between the results obtained with the standard black painted aircraft and with the forward fuselage covered with white paper to simulate a white painted finish.

1.5 Further trials were made on the ground using a sun awning to protect the forward fuselage from the direct rays of the sun.

1.6 Ground cooling trials were made to assess the effectiveness of a Cold Air Minor and a comparison was effected by conducting a brief test with a Godfrey R.2000 Air Conditioning Trolley.

2. Description of Cabin Air Conditioning System

2.1 Canberra WD.954 was a standard aircraft fitted with an installation providing for the circulation of either hot or cold air or a mixture of both to the pressure cabin. Both hot and cold air supplies originated from air bled from the 12th compressor stage of each engine in conjunction with:-

- (a) a Teddington electrically controlled mixing valve.
- (b) a Cold Air Unit Type A.C.R.E.9. (C.A.U.).
- (c) Primary and secondary air coolers.
- (d) a pressure ratio controller. (P.R.C.).

The mixing valve, C.A.U., P.R.C., and the secondary cooler were located in the port wing leading edge between the fuselage and engine nacelle. The primary cooler was fitted in the stbd. wing leading edge close to the fuselage.

2.2 The installation was primarily controlled by three switches fitted on the pilot's starboard instrument panel. One switch marked "HOT" and "COLD" controlled the double acting mixing valve and by "inching" the switch the valve could be set to govern the cabin temperature as required. The other switches numbered 1 and 2, in conjunction with two relays, controlled the hot air supplies by action of two engine isolation cocks. These cocks and also two non-return valves in the same pipe-lines were located in the leading edge of the wings close to the inboard engine ribs.

2.3 The Teddington mixing valve was a double acting unit which could be set in any desired position, the position being communicated to the pilot by an indicator on his stbd. instrument panel.

2.4 The Cold Air Unit had a turbine and a compressor and was self-operating, the r.p.m. being regulated by the quantity of air flowing through it.

2.5 Provision was made in the system for the fitting of two types of P.R.C. The Godfrey Type P.R.C., which was installed throughout these trials,

/was.....

pneumatically operated and located in the pipeline between the mixing valve and the C.A.U. Control of the air flow in the pipeline was by an integral valve in the controller assembly. The alternative installation (a Toddington electrically controlled P.R.C.) was not used. The P.R.C. controlled the pressure between the inlet and outlet of the C.A.U. turbine, and the automatic limitation of the ratio to a predetermined figure prevented the C.A.U. overspeeding.

2.6 To prevent condensation in the pressure cabin a water separator was installed in the cabin supply line aft of a non return valve behind the pressure bulkhead. A drain was fitted between the separator and an outlet on the port fuselage skin.

2.7 To pressurise the cabin the gate valves controlling the air supply from each engine were opened by operation of switches on the instrument panel (see para. 2.2). If warm air was required the temperature control switch could be inched towards the HOT position. Heated air from each engine then flowed through the gate valves and non-return valves to a common pipe line feeding the hot side of the mixing valve. From this unit the supply passed through a constant flow valve (set to deliver 8 lbs. air per minute) to the cabin via the water separator and non-return valve.

2.8 Upon selecting COLD at the temperature control switch, air flowed from the common pipeline through the primary cooler to the cold side of the mixing valve. From the latter unit the partly cooled air passed through the P.R.C. to the compressor of the C.A.U. When the C.A.U. was brought into operation, air entered the unit at the compressor inlet port and passed from the compressor into the secondary cooler. From the secondary cooler, the air re-entered the C.A.U. at the turbine inlet and expanded through the nozzle ring and turbine into the supply ducting.

2.9 A diagrammatic representation of the complete system is shown at Fig. 1, and an installation drawing showing the relative positions of the various units appears at Fig.2. It will be noticed that a supply of air controlled by a constant flow valve was fed to the rear camera when the gate valves were open. This air remained hot irrespective of the position of the mixing valve which controlled only the air supplied to the cabin. Fig.3 shows the arrangement of the C.A.U. installation in the port wing and a sectional drawing of the A.C.R.E.9 unit appears at Fig.4. The ducting for the ram air intake at the primary and secondary coolers is shown at Figs. 5 and 6.

2.10 Air entered the cabin through a pipe passing through the pressure bulkhead. Tappings in this pipe fed air through smaller diameter pipes to:-

- (a) A fishtail forward of the pilot's rudder bar.
- (b) A fishtail at the bomb aimer's window.
- (c) A diffuser on the port side of the pilot's seat.
- (d) 6 louvres permitting individual control of the amount and/or direction of the air flow.

The arrangement of the ducting and the louvres is shown at Fig.7 and positions of the individual louvres appear at Figs. 8 to 13.

2.11 Canberra aircraft not fitted with a C.A.U. are supplied (when unpressurised) with ventilating air through a ram air scoop fitted forward of the canopy. Air passed through a non return valve and water trap, to a louver on the port side instrument panel. (see Fig.7). This installation was not normally intended for use where a C.A.U. was fitted, but was installed for these trials to permit comparative tests to be made as between a standard aircraft and one fitted with a C.A.U.

3. Description of Instrumentation

3.1 The aircraft was fitted with a balanced bridge outside air thermometer and thermometer pencils protected from radiation at the following positions.

/(e).....

- (a) Pilot's head
 - (b) Pilot's hands
 - (c) Pilot's feet
 - (d) Navigator's hands
 - (e) Navigator's feet
 - (f) Bomb aimer's hands
 - (g) Bomb aimer's feet
 - (h) Accumulators
 - (i) Gyro instruments
 - (j) Radio.
- } Seated position.

A psychrometer was installed in the cabin to record the inside humidity during the trials.

3.2 An automatic observer was fitted in the bomb bay to record the behaviour of the cold air system during the trials. Fig.14 shows the arrangement of the auto observer panel together with the instrumentation and ranges. Thermometer pencils and pressure tappings necessary for operation of the auto-observer instruments were introduced as required in the cold air system pipes as shown at Figs. 15 and 16.

3.3 A separate auto-observer installed in the cabin for performance trials was used to collect data for determining the engine compressor pressures available for operating the C.A.U. during ground running and taxiing.

3.4 In order to record engine bay temperatures whilst the aircraft was parked in the sun and also during ground running, thermocouples were fitted in the port engine nacelle in the following positions and a remote reading instrument supplied which could be plugged into a socket in the port wheel well.

- (a) Engine compressor casing.
- (b) Torch ignitor cap.
- (c) Booster coil case.
- (d) Top rear side main spar near jet pipe.
- (e) Inside nacelle skin on centre line, 5" aft of main spar.

4. Description of trials

4.1 Trials were first made under temperate conditions at Boscombe Down prior to departure for Khartoum. The aircraft was flown at 1500' I.C.A.N. at 200, 325 and 485 knots I.A.S. until cabin temperatures had stabilised with the air selected fully cold. During the 200 and 485 knot levels the air supply was selected HOT for a few minutes after take-off in order to induce some heat into the cabin and thereby facilitate assessment of the rate of subsequent cooling afforded by the C.A.U. when the air was selected COLD. During the 325 knot level the air was selected COLD until stabilised temperatures had been recorded and then the gate valves were closed thus blanking off all ventilation to the cabin. The subsequent temperature rise was noted. Automatic observer shots were taken at minute intervals during each flight.

4.2 A Godfrey 3.6 to 1 P.R.C. had been installed during the trials made at Boscombe Down but prior to departure for Khartoum this was removed and a similar unit set to control the pressure ratio at 4.2 to 1 was installed. This unit was found to be unserviceable on arrival at Khartoum and the 3.6 to 1 P.R.C. was refitted for the remainder of the trials.

4.3 During transit from Boscombe Down to Castel Benito and Castel Benito to Wadi-Seidna, a record was kept of the cabin temperatures together with the position of the air conditioning control which was regulated as required to maintain comfort.

4.4 During the flight trials made under tropical conditions at Khartoum the aircraft was flown at 3000' I.C.A.N. at 200 and 325 knots I.A.S.

/until.....

until cabin temperatures had stabilised. The trial was repeated at both speeds, firstly with the C.A.U. in operation and the ram air ventilation off, and secondly (in order to assess the degree of cooling afforded by the C.A.U.) with the ram air on and C.A.U. off. A comparison of the results will be as between a standard aircraft and one fitted with a C.A.U. Sustained low level flying at speeds in excess of 325 knots was found to be impracticable owing to severe bumpiness. Automatic observer shots were taken at minute intervals during the trials made with the C.A.U. on.

4.5 The 200 knot level was repeated at night (under conditions of no solar radiation) both with C.A.U. on and ram air off and vice versa. These trials were made immediately after sundown whilst the O.A.T. was still high enough to allow a reasonable comparison to be made between these results and those obtained during the day. Automatic observer shots were again taken at minute intervals throughout the flight with the C.A.U. on.

4.6 During the trials already described, particular attention was paid to the different levels of comfort experienced during taxiing, both with and without using the C.A.U. The different temperatures recorded under the two conditions are shown in tabulated and graphical form together with the results of the flight trials (see para. 5.3.).

4.7 Ground temperature trials were made to determine the cabin temperatures and humidities reached when the a/c was parked in the sun. Comparative trials were made under the following conditions:-

- (a) Standard black painted aircraft without protective covering or sun awning.
- (b) Standard black aircraft with sun awning in situ in conjunction with a white painted nose bag and a strip of fibreglass over forward fuselage.
- (c) Front fuselage covered with white paper to simulate a white painted finish.

Two views showing the arrangement of the sun awning and white paper covering are shown at Figs. 43 and 44.

4.8 Trials were made to determine the degree of cooling afforded by an M.L. Aviation Coolair Minor, (an air conditioning unit designed for use on aircraft parked in the tropical sun). The aircraft had been parked in the sun from 09.30 to 15.00 hours. The Coolair Minor was started at 15.00 hours during trials (a) and (b) above and cooling continued for 30 minutes. Following completion of cooling, the subsequent rise in cabin temperatures was recorded at 5 minute intervals for a further 30 minutes.

4.9 Prior to departure for Khartoum the Coolair Minor had been tried at Boscombe Down and it had been found expedient to provide a diffuser nozzle at the outlet of the delivery hose to distribute the flow of cooling air more evenly throughout the cabin. The diffuser was used during all the subsequent trials made at Khartoum. A photograph of the diffuser appears at Fig. 45 and the arrangement of the Coolair Minor during the trials is shown at Fig. 46.

4.10 A Godfrey R. 2000, Air conditioning Trolley was available for a short period and brief cooling trials were made under condition (b) above to obtain further data on the amount of flow required to provide adequate cooling. A general arrangement of the Godfrey R. 2000 Trolley is shown at Fig. 47.

4.11 Engine bay temperatures at the positions mentioned in para. 3.4 were noted whilst the aircraft was parked in the sun during trial (b) (see para. 4.7). These temperatures were also recorded during ground running.

4.12 In order to collect data on possible canopy misting the aircraft was flown from Khartoum to Aden at 43,000' I.C.A.N. This was followed by a maximum rate descent at 6500 R.P.M., Mach No. .8 and dive brakes out, to 3,000' I.C.A.N. (mean descent rate approx. 8000 ft. per minute). The air conditioning control remained in the hot position throughout the transit flight and during the first part of the descent but was selected cold at 20,000' I.C.A.N. during the descent.

4.13 In order to determine the need for and effectiveness of the water separator, trials were made at Aden both with and without the separator. The trials included flights at 100 ft. over the sea at various airspeeds up to 350 knots I.A.S. The effects of fogging and condensation in the cabin were noted during the flights both with and without the separator.

5. Results of Trials

5.1 The tabulated results of the trials made at Boscombe Down are shown at Figs. 17 to 19, and graphs showing the temperature ranges throughout the flights appear at Figs. 20 to 22. A graph showing the average cabin temperatures during the same flights is shown at Fig. 23.

5.2 The tabulated results observed during the transit flights are given at Fig. 24 and graphs showing changes in the average cabin temperature and position of the air conditioning control appear at Figs. 25 and 26.

5.3 Results of the trials made during daylight at Khartoum are given in tabulated form at Figs. 27 to 30. Graphs showing the temperature changes recorded during the flights appear at Figs. 31 to 34 and comparisons of the average cabin temperatures are shown at Figs. 35 and 36. The results of the trials made at night are similarly shown at Figs. 37 to 41 whilst a comparison of the average cabin temperatures recorded during the three flights made with the C.A.U. on is shown at Fig. 42.

5.4 The temperatures recorded whilst the aircraft was parked in the sun and during the subsequent cooling trials are shown in tabulated form at Figs. 48 to 50. The average cabin temperatures under the three conditions (see para. 4.7) is shown at Fig. 51.

5.5 Engine bay temperatures recorded both during ground running and with engines stopped are given at Figs. 52 and 53.

5.6 The effects of canopy misting during a rapid descent and of fogging up during flight without a water separator are discussed fully at paras. 8.2 and 9.2.

6. Discussion on Cabin Temperature Results

6.1 During all the cabin temperature trials the average of the seven temperatures recorded at distributed points in the cabin is considered to be the best possible indication as to the degree of heating or cooling afforded by the air conditioning system.

The individual measurements at the same seven positions show the effective distribution of the heating or cooling supplied.

6.2 The amount of cooling afforded to the cabin by the Cold Air Unit and its associated components appeared to the crew to be reasonably evenly distributed although the temperature range at the stabilised condition of each trial was well above the 5°C recommended by A.P. 970. Fig. 54 shows the actual temperature ranges recorded during the flights with cold air on and each graph has similar tendencies, the temperature at the pilots feet being the lowest in each case. It would appear that diversion of some of the flow from this position to other parts of the cabin would result in a more even temperature distribution. The same ducting is also used for supplying heated

/air.....

air to the cabin at high altitude and reference to the results of the transit flights at Figs. 24, 25 and 26 will show that with an O.A.T. lower than -55°C the heating supply is ample to maintain comfortable cabin temperatures (average 24°C) even without selecting fully hot. With an O.A.T. of -75°C (A.P. 970's minimum essential requirement) it is unlikely that cabin temperatures will fall below zero and they should certainly remain well above -5°C (A.P. 970 minimum requirement).

The temperature at the pilot's feet during transit was at all times within 4°C of cabin average and it would appear that alterations to the supply ducting to distribute the cold air more evenly would have adverse effects on the hot air supply. The present arrangement can then be considered satisfactory as regards distribution of the air but further comments and suggestions for modifications are discussed at para. 6.12.

6.3 Reference to Figs. 17 to 22 giving the results of the trials made at Boscombe Down will show that a cold air system is desirable for low level flying (particularly at high speeds) even under temperature conditions.

The average stabilised cabin temperature with an O.A.T. of 12°C was 1°C higher than A.P. 970 max. (33°C) at 485 knots, the highest temperature recorded being 40°C at the bomb aimers hands. It appears that a greater degree of cooling is desirable even under temperate conditions.

6.4 During the 325 knot flight at Boscombe Down the gate valves were closed after the temperatures had stabilised and although the temperature at the pilots head showed a rise of 17°C in 15 minutes, the average temperature rose only 4°C in the same time although no ventilating air from any source was being provided.

6.5 The results of the trials made at Khertoum are shown at Figs. 27 to 41 and comparison of the average stabilised temperatures recorded during these flights both with and without using the C.A.U. show that only a small reduction is afforded by the unit.

At 200 knots the average temperature with ram air ventilation only was 50°C and with C.A.U. on was 4°C lower. At 325 knots the average temperature with ram air only was 50°C and with C.A.U. on was 9°C lower.

Although the temperature reduction afforded by the C.A.U. was small the difference in crew comfort was very noticeable and out of all proportion to the small change in actual temperature.

It is apparent that temperature alone is not an indication as to comfort and that other factors are assisting the maintenance of comfort at temperatures normally considered excessive. It is well known that a more reliable index of crew comfort is given by "effective temperature"; but due to uncertainty in the measurement of humidity, this has not been quoted.

Acute discomfort was experienced by the crew when flying under conditions of ram air ventilation only. Rapid perspiration continued throughout these flights and the relief felt when the C.A.U. was eventually switched on was immediately noticeable notwithstanding a negligible temperature drop.

6.6 The relative humidity in the cabin under conditions of ram air ventilation only, varied from 71 to 83% and with C.A.U. on from 62 to 70%.

The lower relative humidity could account for a small improvement in comfort during the trials with cold air on but the effect of this would be hardly noticeable. The vastly improved comfort level with cold air on is probably due to maintaining a high flow of cool air over each crew member thus assisting the rapid evaporation of perspiration resulting in a feeling of comparative comfort. It is probable that flight under conditions of ram air ventilation only would not have been so severely uncomfortable if the air had been supplied in the same positions and in the same quantity as

/the.....

the cold air. It was however supplied through one louvre only (see Fig.7) and in insufficient quantity to prevent stagnation in most parts of the cabin. The amount of ram air supplied through this louvre was in fact less than 1/40th. of that supplied by the C.A.U.

6.7 The clothing worn during the trials varied but was at all times roughly the equivalent of a lightweight flying suit over vest and trunks.

The degree of comfort attributed in para. 6.6 to a flow of cool air to assist evaporation of perspiration would not be so apparent if heavier clothing were worn in preparation for high altitude flying with the possible necessity of abandoning the aircraft.

6.8 The actual temperatures recorded during flights made at 20,000 and 30,000 feet with cold air on are not quoted in this report but it was particularly noticed that the crew members who had become acclimatised to tropical conditions began to feel very cold when the average cabin temperature fell to 20°C. With an average temperature of 40°C each crew member felt comfortable although this is 7°C above A.P. 970 max. A.P. 970 minimum requirement of -5°C may be sufficient to maintain comfortable conditions for persons accustomed to arctic conditions but the heating supply necessary to meet this requirement would be inadequate during high altitude flying by crew members acclimatised to higher temperatures.

6.9 The comfort levels noted during these trials are so widely divergent from A.P. 970 requirements that it is considered unwise to attempt to correct the recorded temperatures to A.P. 970 max. and min. conditions.

In view of the probable inaccuracy of any correction factor used for this purpose the resultant figures would in any case be misleading.

6.10 During taxiing the C.A.U. was found to be of but little assistance in lowering the cabin temperatures and generally uncomfortable conditions prevailed until take-off when a strong stream of cold air emitted from the louvres offered immediate relief.

It is again pointed out that lightweight clothing was worn during these trials and the relief afforded by the airstream would not be so apparent if heavier clothing had been worn in anticipation of high altitude flying.

Conditions whilst taxiing with the C.A.U. on were noticeably more comfortable than with ram air only and this was due mainly to the emission of puffs of cooling air when the engine R.P.M. were occasionally increased, thus preventing the stagnation which prevails in the cabin when ram air only is selected.

Fig. 55 shows the engine compressor pressures available for air conditioning during ground running and it is apparent that only a negligible degree of cooling can be expected during the normal taxiing range.

The variation in mass flow with engine delivery pressure is shown at Fig. 56. At the pressures available during taxiing a mass flow in excess of 4 lbs. of air per minute is unlikely even during short bursts.

6.11 The entry of all air supplied to the cabin is via the louvres and fishtails shown at Figs. 7 to 13.

Although the present distribution of the conditioning air supply is generally satisfactory it is considered that a substantial increase in mass flow will be necessary if comfort is to be achieved by low cabin temperature rather than by the present arrangement of localised cold air streams.

The former is obviously preferable if it can be attained as it would provide for heavily clad crew members.

/The.....

The existing arrangement of cabin ducting is however unsuitable for the provision of a mass flow greater than that already supplied as the strong airstreams experienced at high speeds became distracting and the design of the louvres is such that any attempt to deflect the air stream results in a corresponding reduction in area of the internal orifice, thereby restricting the flow.

The provision of a greater mass flow would then necessitate either an increase in the number of louvres or preferably a redesigned form of ducting with provision for diffusing the supply of air at the cabin inlets.

A length of perforated tubing surrounding the cabin at two or more different levels is envisaged as a possible improvement but only if the mass flow is substantially increased. The provision of this form of ducting without improving the supply could result only in reducing the cooling effects provided by the existing localised cold air streams.

An improved form of louvre permitting deflection of the air stream in any desired direction without affecting the flow would however improve the present system. Reference to Fig. 7 will show that apart from the louvres the only air supply to the cabin is via two fishtails and one small diffuser. Closure of the louvres and diffuser, (which could happen during flight by independent aircrew action) would heavily restrict the flow and possibly cut the supply to a level less than the cabin leak rate thereby preventing effective pressurisation, particularly if the fishtails became damaged (see Fig. 13).

6.12 Except whilst parked in the sun and during subsequent taxiing the temperatures at the accumulators, radio and gyro instruments are not likely to exceed the A.P. 970 maximum of 55°C although reference to Fig. 24 shows that the temperatures at the accumulators fell below A.P. 970 minimum (0°C) during the transit flight at 42,000 ft. with O.A.T. -57°C.

The actual temperature recorded was -5°C and this would become substantially lower at the A.P. 970 minimum essential condition (-75°C).

6.13 Following the low level flights at Khartoum it was discovered that the hot air supply fed to the rear camera had melted the gelatine emulsion on the filter.

Reference to Fig. 1, will show that the air supplied at this position is tapped directly into the engine compressor line and is always hot irrespective of the position of the cabin conditioning control. The temperature of the air emitted at the camera was not recorded but reference to Fig. 57 shows that it could be as high as 250°C.

The provision of a thermostatic unit to control the supply at this position appears desirable although diversion of some of the flow to the accumulator bay (see para. 6.12) might stop recurrence of this trouble providing sufficient heat is still maintained under low temperature conditions.

7. Discussion on ground temperature and cooling results

7.1 The cabin temperatures recorded whilst the aircraft was parked in the sun and during subsequent cooling trials with the Coolair Minor and R2000 trolleys are given at Figs. 48 to 51.

7.2 If the standard black painted aircraft remains in the sun unprotected, the temperatures throughout the cabin become excessive and all metal parts become too hot to touch with the naked skin. The highest temperature recorded was 81°C at the pilots head when O.A.T. was 41°. The average temperature was 68°C and the range between the highest and lowest temperatures was 21°C. Buckles of parachute harnesses left in the seats became so hot that fitment of the parachute was an uncomfortable process and the hot metal parts could be felt through the clothing. Entry into the cabin was difficult in view of the high temperatures of the metal

/structure.....

around the door and vital controls were too hot to touch unless gloves were worn.

7.3 Steps taken to keep the temperatures at comfortable levels included use of the sun awning depicted at Fig.43. The highest cabin temperature recorded whilst the awning was in situ was 47°C at the pilot's feet when O.A.T. was 41°C. The average temperature was 46°C and the range between highest and lowest temperatures was only 3°C.

To aircrew acclimatised to tropical conditions the rise of 5°C on entering the cabin was not uncomfortable; in fact entry offered shelter from the direct rays of the sun and conditions were more tolerable than when standing outside unsheltered.

The awning was used throughout the trials made at Khartoum and was left in position during starting up and removed only when the pilot signalled "checks away". The subsequent rises in cabin temperatures whilst taxiing varied from 3 to 6°C in an average taxiing time of 5 minutes.

7.4 Further trials with the forward fuselage covered with white paper as shown at Fig.44 resulted in a maximum temperature at the pilot's hands of 63°C when O.A.T. was 41°C. The average temperature was 56°C and the range between highest and lowest temperatures was 13°C.

Entry into the cabin under these conditions was still uncomfortable but a marked improvement on the conditions that prevailed during the trial without protection.

The effect of a white painted finish on cabin temperatures during taxiing and in flight could not be tried but the results obtained during ground trials show substantial reductions in temperatures and it is considered that a marked improvement would be noticed during flight.

Fig. 44 shows the white paper coating extending over the pilots canopy as far as a straight line drawn between the two aerials. It was found that this did not affect the range of vision of the pilot when his harness was fastened, in fact the cover could be extended a further 6" forward on the centre line of the aircraft with a gradual sweep back to the tops of the aerials. The cooling advantages of reducing the area of transparency are obvious, and since the alteration is so simple it is felt that Service experience should be obtained by Squadrons in tropical areas.

7.5 The cooling trials made with a Coolair Minor showed a drop in average cabin temperature of 18°C in 30 minutes with an unprotected aircraft and 7°C in 30 minutes when the awning was in situ.

The subsequent rises in temperature when cooling ceased were respectively 7 and 5°C in 30 minutes. In view of the successful results obtained with the awning it is considered that the degree of cooling afforded by the Coolair Minor does not merit its use for cabin cooling on this type of aircraft. Entry of the large diameter hose through the small doorway restricts the space available for servicing and this method of introducing cooling air is not recommended.

7.6 Although use of the Coolair Minor for cabin cooling is considered unnecessary it has been employed successfully for maintaining suitable working conditions for servicing personnel (not necessarily in the cabin).

The rate of flow and temperature of the air supplied are insufficient to cause a physical shock due to too rapid cooling and this trolley is ideally suited for the purpose stated.

7.7 Brief cooling trials made with a Godfrey R.2000 Air Conditioning Trolley resulted in a drop in average temperature from 48 to 32°C in 10 minutes. The O.A.T. was 41°C and sun awning was in situ.

/This.....

This result however was only to be expected with a trolley having the capacity to cool large passenger aircraft.

8. Discussion of Canopy Misting Test

8.1 During the high altitude transit flight preceding the maximum rate of descent for assessing canopy misting effects, the whole canopy forward of the aeriels iced up between the sandwich layers. The aircraft had to be flown on instruments throughout the flight as the only part of the canopy forward of the aeriels through which vision was possible was within a 2" radius of the air inlet. The D.V. panel remained clear but its position is not suitable for constant use.

The icing appeared to be on the inner surface of the outer canopy layer and formed rapidly on climbing above 30,000 ft. During descent the ice thawed rapidly below 30,000 ft. and at 5,000 ft. the canopy was practically clear except for water droplets which remained for some time.

8.2 Misting on the inside of the canopy occurred during the descent but owing to the presence of the ice between the layers an assessment of the effect of misting on forward vision could not be made.

The misting did not appear to be severe; it could be wiped off easily with the hand without rapidly reforming and cleared quickly at low altitude.

9. Discussion on water separator trials

9.1 Trials to assess the need for and effectiveness of a water separator were made at Aden where it was hoped conditions of high humidity and temperature would prevail. The actual conditions experienced during the trial (O.A.T. 34°C and R.H. 50%) were not as severe as was expected but the necessity of a separator was established.

9.2 The trial with the water separator removed was made at 100 feet over the sea and within a few minutes after take-off the rear portion of the cabin had become so badly fogged up that instruments only 15" away from the observers eye could not be read.

The jets of vapour emitted from the louvres were about 12" long at 200 knots and increased to about 30" long at 350 knots.

Water condensed on all the cabin structure and ran in rivulets to form puddles on the floor.

The forward cabin remained fairly clear although the bomb aimer's window was quickly covered with water drops which ran down to form a puddle at the bottom of the window. The pilot's position remained clear the whole time and no misting occurred on the canopy. This is plainly due to solar radiation and it is probable that at night the absence of solar radiation combined with the effects of higher humidity would cause severe fogging in the whole of the cabin. Fogging to the extent stated showed no change at altitudes up to 4,000 ft. but thereafter gradually decreased until at 7,000 ft. only short jets of vapour were emitted from the louvres and the cabin was clear throughout.

9.3 Reinstallation of the water separator following by a repeat of the previous trials resulted in no fogging or condensation.

The louvres did at times emit short jets of vapour but these rapidly dispersed and caused no embarrassment. Minor fogging may occur under conditions of higher humidity but should not be severe.

10. Discussion on the Cold Air System

10.1 The overall performance of the installation was disappointing due mainly to the low engine compressor pressures at low R.P.M. and the resultant small mass flow.

10.2 The loss of performance at low engine speeds could be slightly improved by increasing the diameter of the high pressure pipes but the increase in flow thus derived cannot be expected to be substantial.

10.3 During the trials at Khartoum the cabin outlet temperatures were approximately 11°C below the average cabin temperature and more efficient use of the cold air supplied to the cabin might be obtained by installing baffles in the region of the discharge valve.

10.4 Graphs showing temperature and pressure variations in the cold air system are shown at Figs. 57 and 58 whilst variation in pressure ratio with engine delivery pressure is shown at Fig. 59. From the latter it appears unlikely that pressure ratios in excess of 3.6 to 1 will be attained and as the unit is already suitable for operation at a ratio of 4.2 to 1 it may be possible to discard the P.R.C. Further trials with an improved production version of the system may substantiate these observations.

10.5 A mass flow sufficient to cool the cabin during taxiing can never be attained with the present system which derives its supply of air from the engine compressor casing.

The provision of separate engine driven compressors could however provide an adequate supply of ventilating air which due to inefficiency of the heat exchangers during taxiing may not be delivered at very low temperatures but would prevent stagnation in the cabin and possibly keep the temperatures lower than does the present arrangement.

10.6 Fig. 60 shows the observed variations in mass flow with indicated air speed and it is noted that the flow does not materially increase at speeds in excess of 350 knots.

11. Defects experienced during Cold Air Unit trials

11.1 Apart from the unserviceability of the 4.2 to 1 P.R.C. mentioned in para. 4.2 all major components in the system behaved in a satisfactory manner throughout the trials, although some troubles were experienced with ancillary equipment (see below).

11.2 The screwed type of pipe connection used for the high pressure pipe run between the gate valve and Teddington control valve was mated with threads of like material which picked up when attempts were made to tighten or loosen the joint.

Bad leaks had occurred at these joints and an improved method of mating the pipes is desirable.

11.3 The clamped type of pipe coupling used elsewhere in the system is generally satisfactory but prone to overtightening. Failure of a clamp during the trials was attributed to this and a redesigned clamp to prevent overtightening is recommended.

11.4 Pipe lagging on the system had been carried over the pipe joints preventing easy inspection and access. It is considered that the amount of heat lost by omission of lagging from the region of the joints would be negligible.

11.5 Failure of the diaphragm in the port engine A.C.U. led to strong kerosine fumes entering the cabin via the cold air system. The tappings in the engine compressor casing for the cold air system and for the pressure line to the A.C.U. are closely spaced and a wider spacing should prevent recurrence of this trouble.

12. Conclusions and Recommendations

12.1 The stabilised cabin temperatures reached whilst taxiing and during all conditions of low level flying in tropical conditions with the

C.A.U. in operation are in excess of the A.P. 970 recommended maximum (33°C) but providing the crew are acclimatized to high temperatures and wear light-weight clothing, comfort is maintained at a satisfactory level by virtue of the jets of cooling air emitted from the louvres.

Although the cabin conditions are a marked improvement over those prevailing in an aircraft not fitted with a C.A.U., it is considered that the degree of cooling afforded by the unit will be insufficient to maintain comfort if the crew are heavily clad in preparation for high altitude flying.

Modifications to increase substantially the mass flow and to diffuse its entry into the cabin are recommended, particularly at the low engine R.P.M. used whilst taxiing.

12.2 The results of the ground temperature and cooling trials lead to a recommendation that the aircraft be finished with a glossy white surface particularly over the upper surface of the forward fuselage and canopy. Sun awnings should be introduced as standard equipment and consist of white canvas stretched over collapsible structures to permit simple storage and transit.

Cooling trolleys are not necessary for preparing the cabin for the aircrew but should be introduced in small numbers for servicing use.

Where the introduction of cooling air to an aircraft cabin is necessary it is recommended that the supply from the cooling trolley be fed into the aircraft's normal ducting by means of an adaptor (for attachment of the delivery hose) which should be situated externally e.g. in the wheel well. This would leave the cabin doorway free of restrictions and permit easier access for servicing personnel.

12.3 It is recommended that the hot air supply to the rear camera be controlled as required to prevent damage to the camera filters and that additional heating be provided at the accumulators.

12.4 The water separator is an essential component of the cold air system and should remain fitted.

If the mass flow is increased a larger capacity separator may be necessary.

13. Further developments

13.1 Further trials will be necessary if the cold air system is modified in accordance with the recommendations made in para. 12.1.

A repeat of the trials made at Khartoum may however be unnecessary and a comparison of results with those already obtained under temperate conditions may be sufficient.

13.2 The results of cabin heating trials made in the U.K. after return from Khartoum will be the subject of a separate report.

Circulation List

A.D.R.D.L.2 2 Copies 1 for Action
T.P.A.3/T.I.B.1c 75 Copies
R.T.O. English Electric 2 Copies

SK 100470 REPORT NO. A. E. E. / 86/1 CANBERRA WD 934 TR. S. M. CH. W.P. WHITE APP. G.H.C. for Sef E (3753)

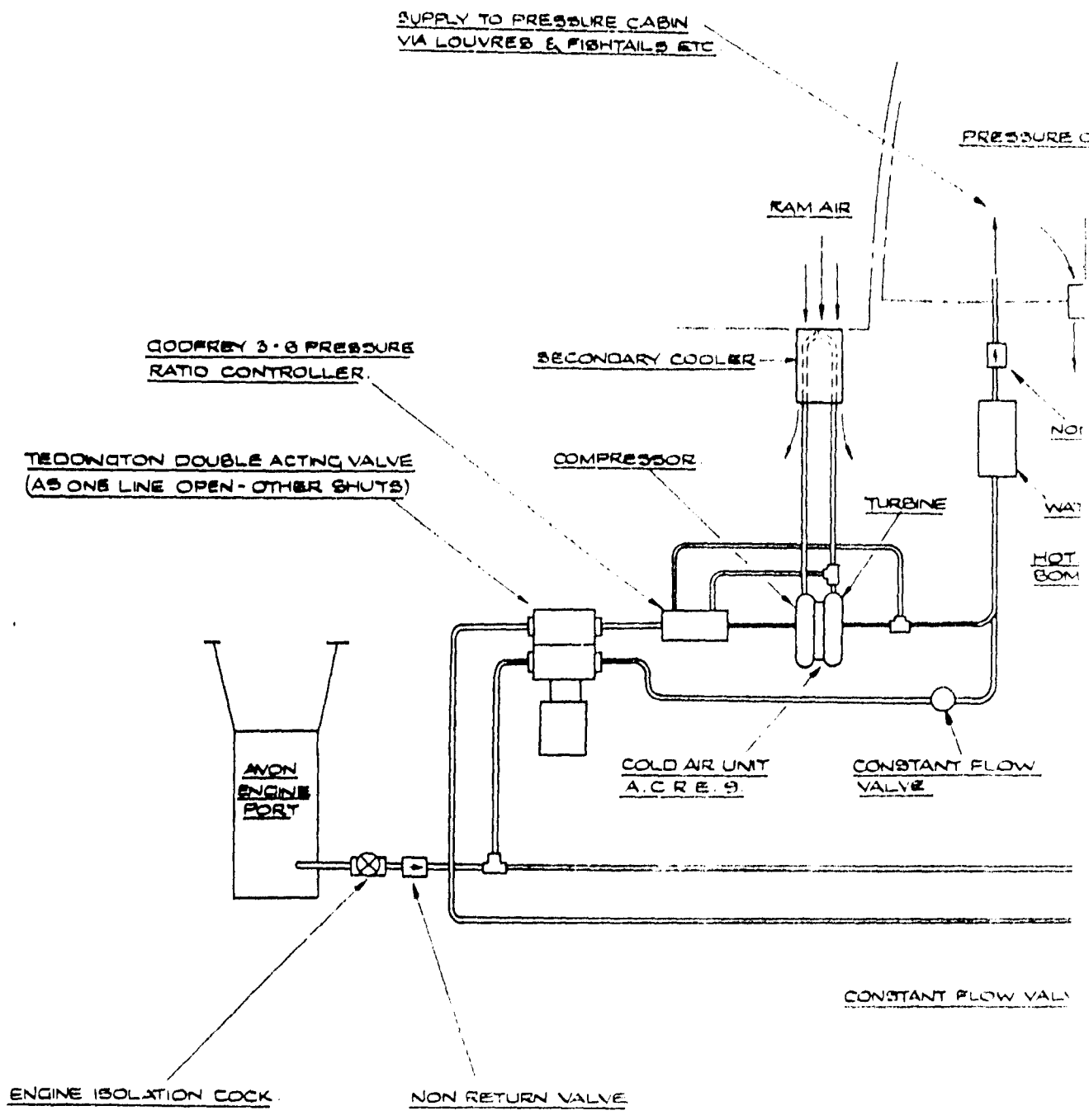

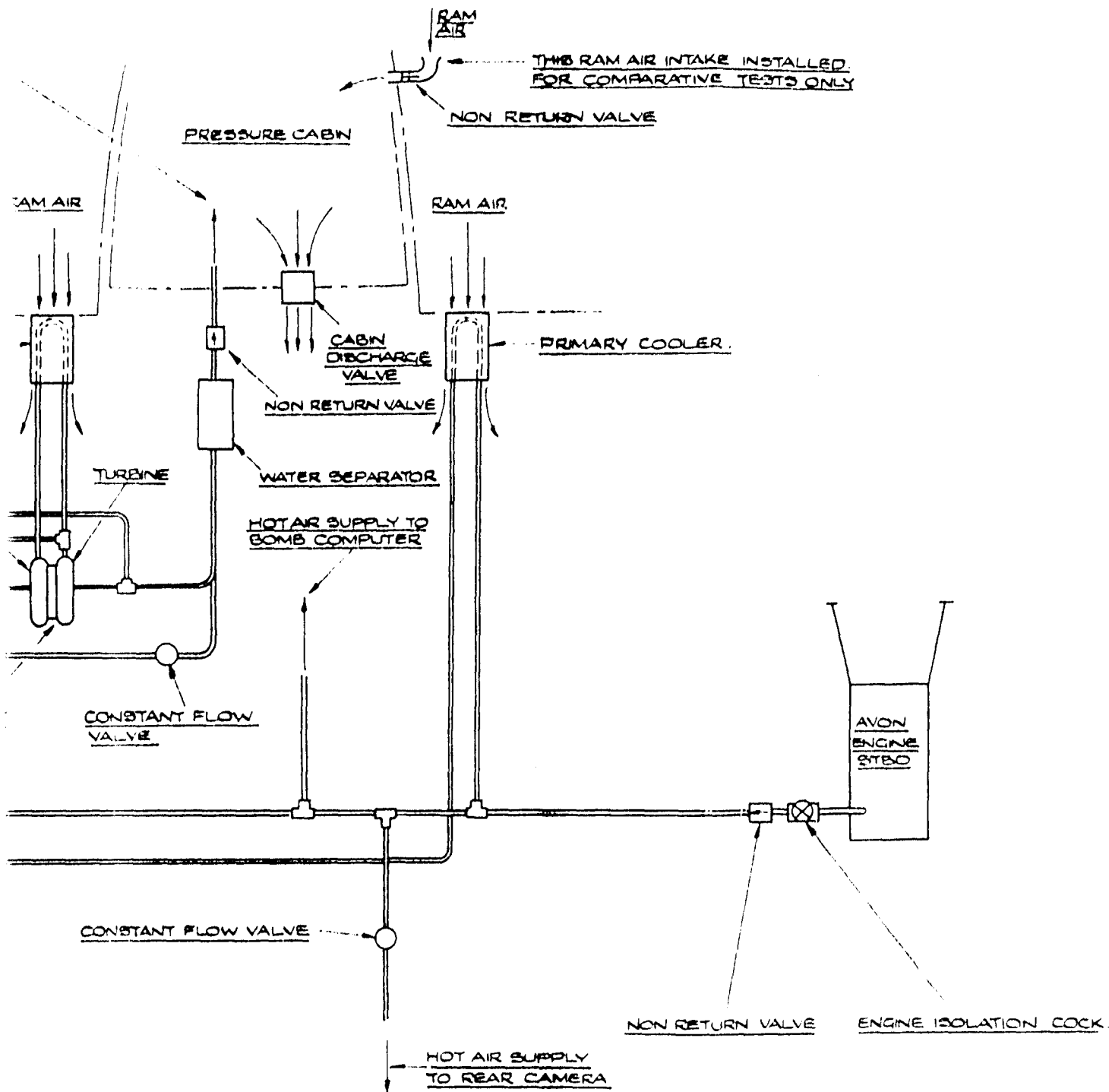

DIAGRAMMATIC REPRESENTATION OF CABIN HEATING & COOLING SYSTEM.

FIG.2.

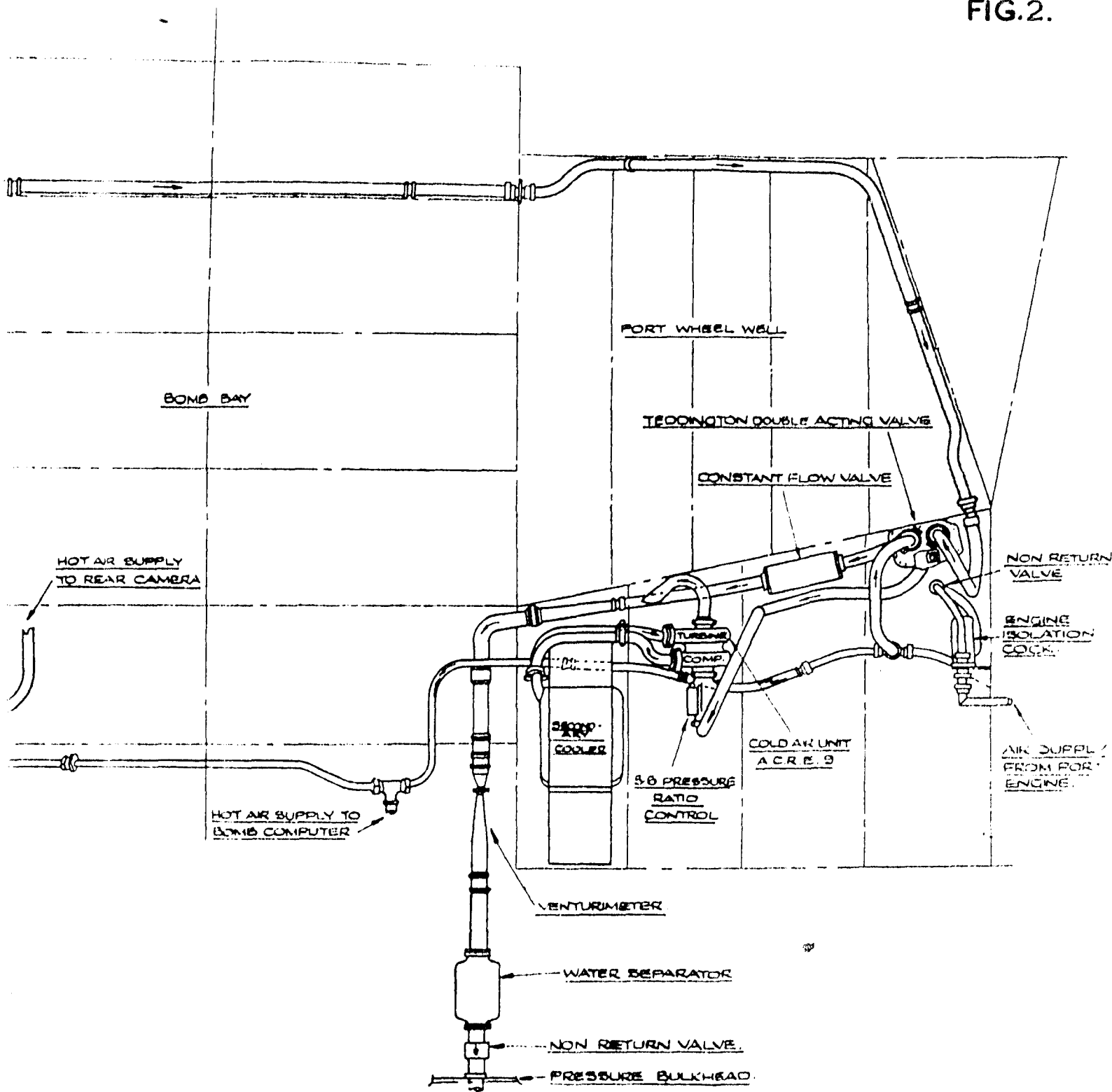

INSTALLATION OF CABIN HEATING & COOLING SYSTEM.

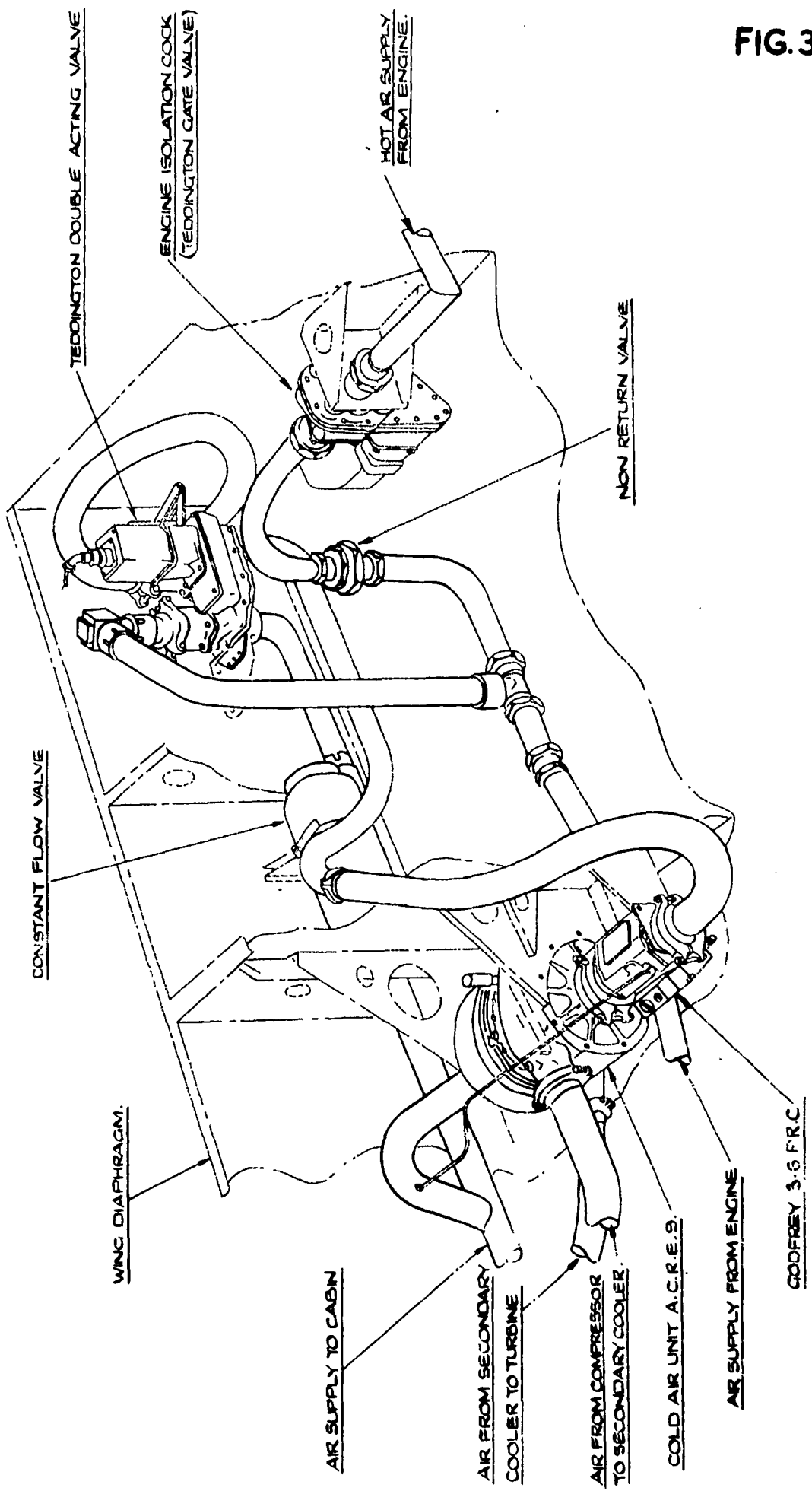
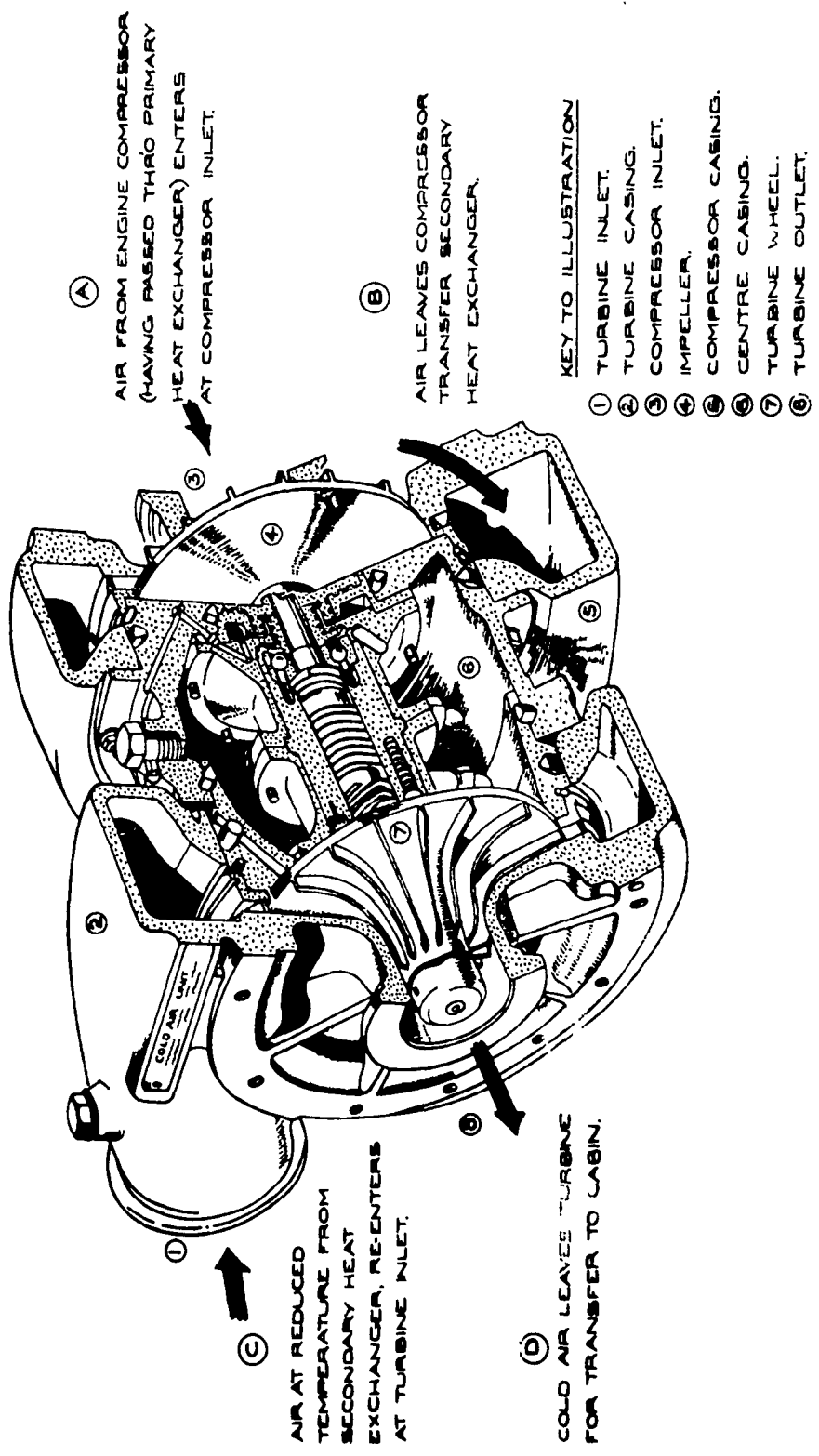

FIG. 3.

ARRANGEMENT OF C.A.U. INSTALLATION IN PORT WING.

FIG. 4



A.C.R.E. 9 COLD AIR UNIT.



View of secondary cooler intake (port)
FIG.5.

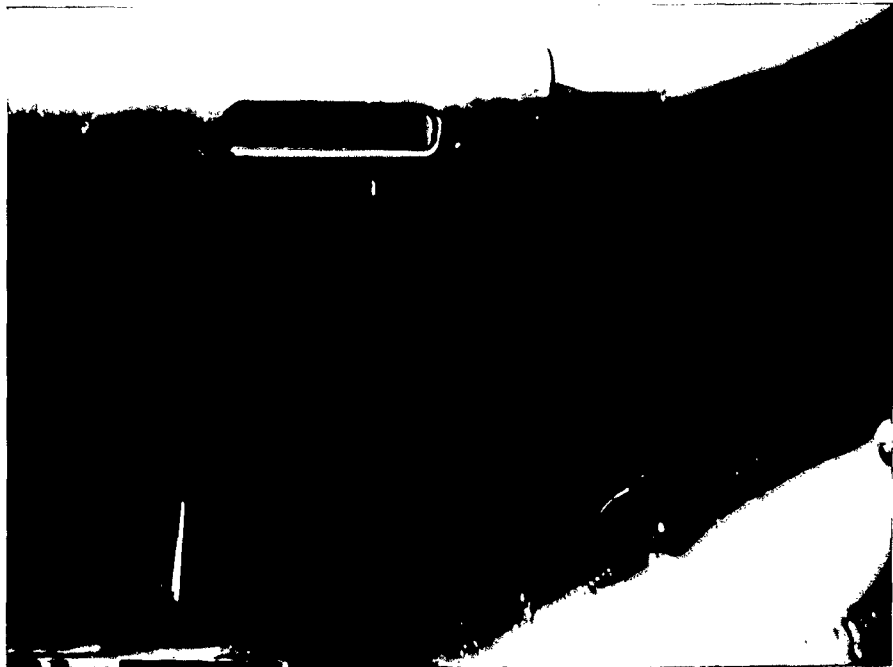

View of primary cooler intake (stb).
FIG.6.

SK 198A-1777 DEPARTMENT OF REPORT NPAA&E.E/ 86111 CANBERA WD 954 TR. S.M. CH. W.P. WHITE. APP. 6000 for Sof E. 20 7 1953

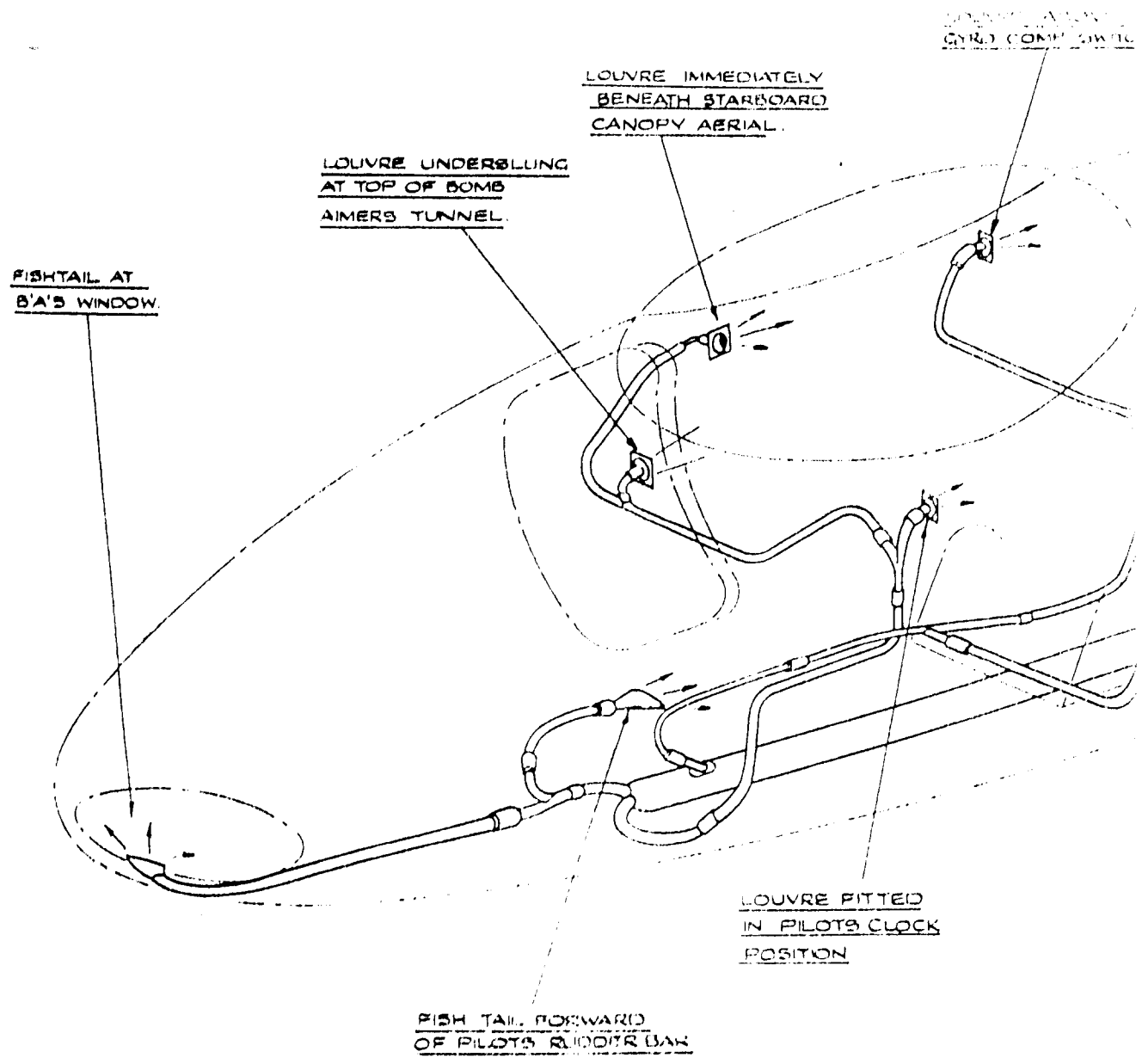

FISHTAIL AT
B'A'S WINDOW.

LOUVRE UNDERSLUNG
AT TOP OF BOMB
AIMERS TUNNEL.

LOUVRE IMMEDIATELY
BENEATH STARBOARD
CANOPY AERIAL.

GYRO COMP SWICH

FISH TAIL FORWARD
OF PILOTS RIDDIT BAR

LOUVRE FITTED
IN PILOTS CLOCK
POSITION

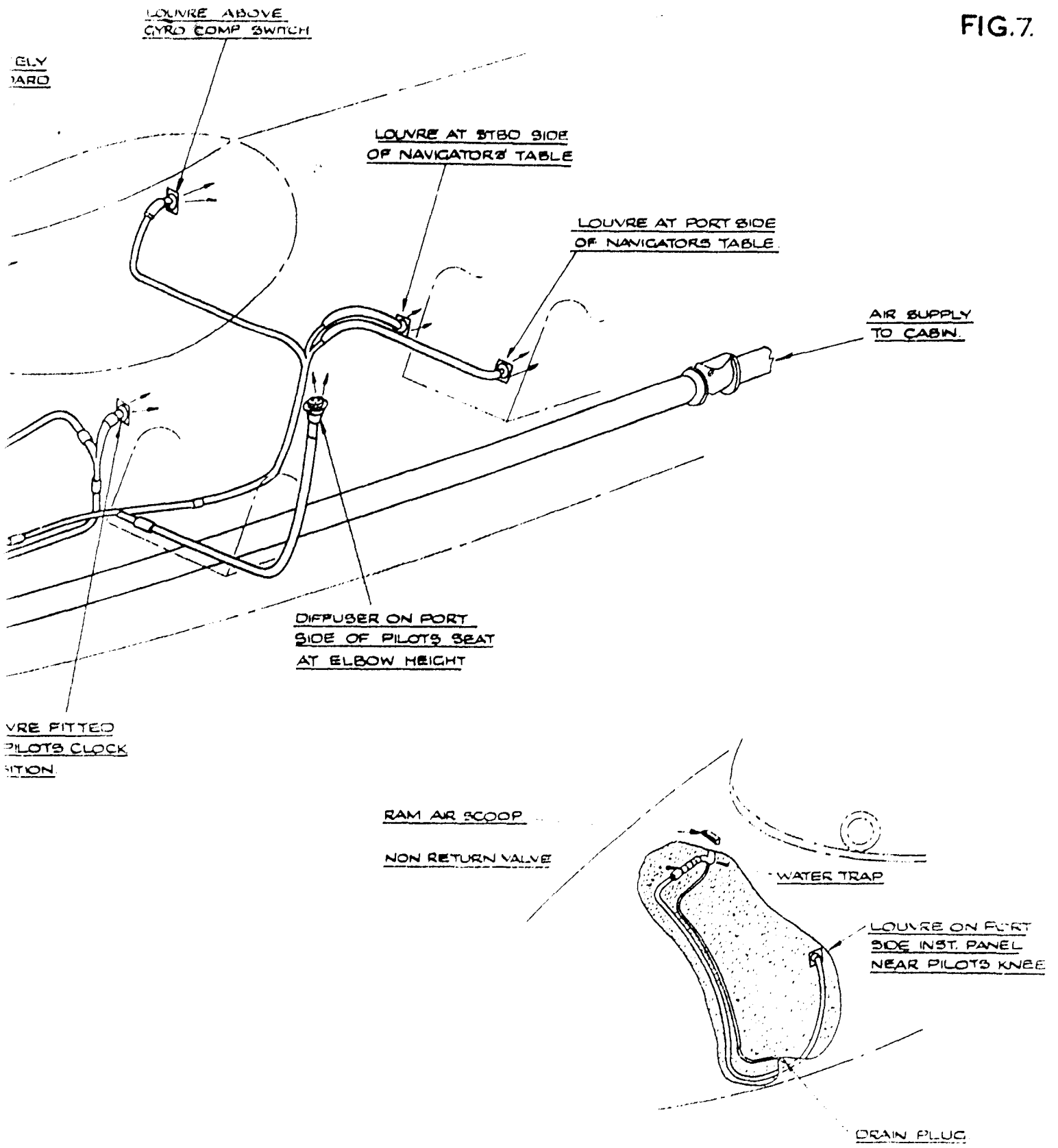

THIS PART OF INSTALLATION NOT NORMALLY
INTENDED FOR USE IF C.A.U. IS FITTED, BUT
WAS ADDED TO TRIALS AIRCRAFT TO FACILITATE
ASSESSMENT OF C.A.U. AS COMPARED WITH A
STANDARD AIRCRAFT.

**ARRANGEMENT OF DUCTING & LOUVRES ETC.
FOR CABIN AIR CONDITIONING.**



View of louvre in pilot's cockpit position.

[FIG. 8.]



View of louvre above bomb aler's tunnel.

[FIG. 9.]

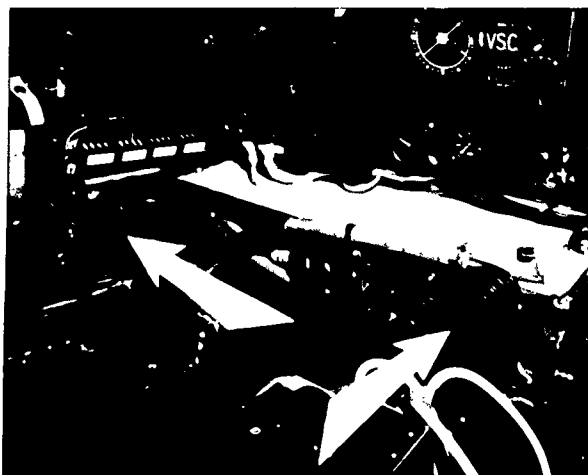

View of louvres at navigator's table.

[FIG. 10.]



View of diffuser port side of pilots seat

FIG.11.

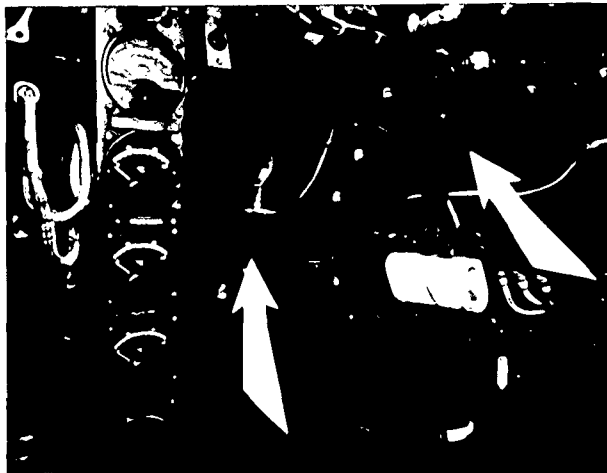

View of louvres on stb side of cabin

FIG.12.



View of fishtail forward of rudder bar

FIG.13.

FIG.14.

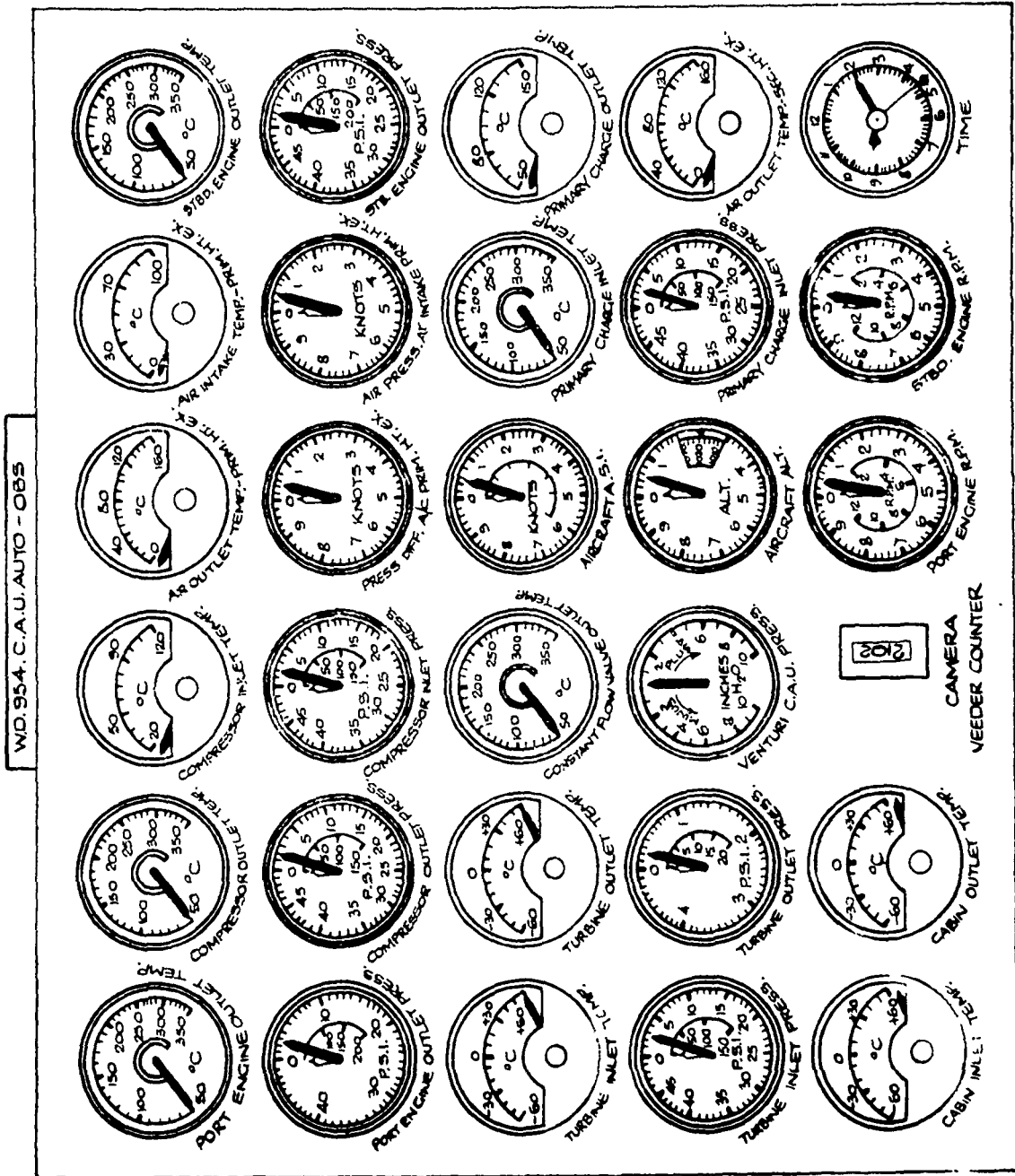

COLD AIR UNIT AUTOMATIC OBSERVER INSTRUMENTATION AND RANGES.

SK N^oA 4779 22nd PART OF REPORT NO A&A.E.E. / 861/1 CANBERRA WD 954 TR. M. O. CH. W.P. WHITE. APP. - 8.6.53. for S of E. 20-7-53.

FIGS. 15 & 16

FIG. 15

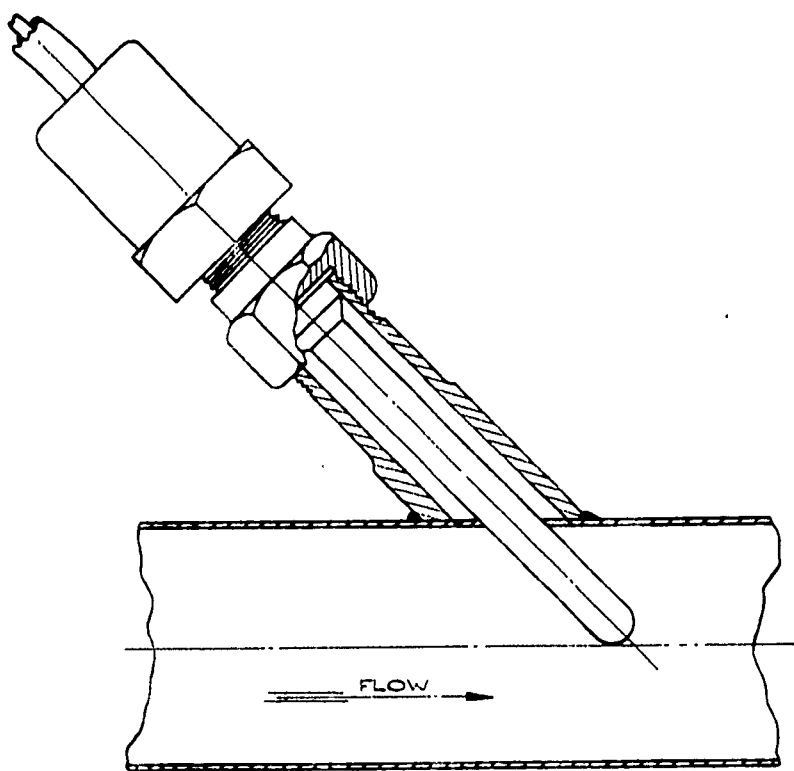

METHOD OF INTRODUCING THERM. PENCIL IN PIPE.

FIG. 16

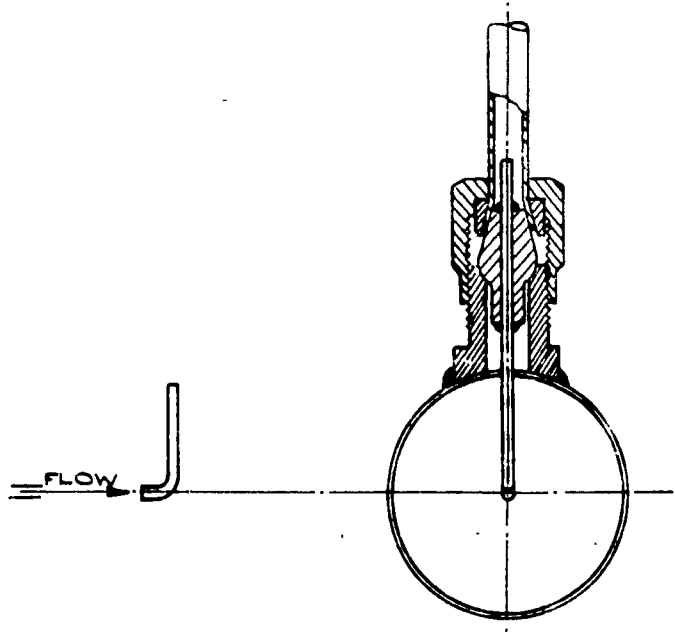

METHOD OF INTRODUCING PRESSURE TAPPING IN PIPE.

Canberra WD. 954

Trial made at Boscombe Down on 9.6.52

Start up 1825 hrs.

Taxi 1826-1830 hrs. Take-off 1831 hrs.

I.A.S. 200 knots

Altitude 1500 ft. I.C.A.N. Outside R.H. 94%

Local time		1826	1830	1832	1835	1840	1845	1850	1855	1900	1905	
Engine	Port		2500	7700	6200	6200	6200	6200	6100	6100	6700	
R.P.M.	Stbd.		2600	7700	6200	6200	6200	6200	6100	6100	6700	
Cabin	Inlet		25	10	60+	60+	2	0	0	0	0	
Temp	Outlet		25	25	28	30	28	25	22	22	22	
Engine outlet temp.	Port		60	210	150	150	150	150	150	150	190	
	Stbd.		70	210	150	150	150	150	150	140	190	
Engine Outlet Press.	Port		6	70	29	29	29	29	28	28	46	
	Stbd.		6	70	29	28	28	28	27	27	47	
Turbine Temp	Inlet		25	25			22	22	22	25	25	
	Outlet		20	0			0	0	0	0	0	
Turbine Press.	Inlet		1	47			23	23	22	22	40	
	Outlet		1/2	5-			2 1/2	2 1/2	2 1/2	2	8	
Compressor Press.	Inlet		3	50			25	15	15	15	31	
	Outlet		2	27			40	24	23	23	42	
Compressor Temp.	Inlet		30	35			80	40	35	35	45	
	Outlet			80				75	75	75	80	
Primary charge Temp.	Inlet											
	Outlet											
Air Temp at Primary Heat Exch.	Inlet		30	40			40	40	40	40	45	
	Outlet		25	25			20	20	20	20	20	
Air Temp.-outlet Sec.Ht.Ex.			30	30			35	35	35	35	40	
Air Press.-intake Prim. Ht.Ex.kts.							170	180	160	160	200	
Press.Diff./C Prim.Ht. Ex. kts.							130	130	120	120	150	
C.F.V. Outlet Temp.							110	75	70	60	50	
Venturi C.A.U. Press.			0	7			2	1 1/2	2	2	3	
Primary charge inlet press.			3	61			20	20	18	18	37	
Pressure Ratio			1	2.6			2.25	2.2	2.2	2.25	2.45	
Mass Flow lbs/min.				9.6			12.1	12.1	11.9	11.8	17.9	
C.A.U. R.P.M.				44100			39000	39000	41800	41800	39000	
Cabin Temperatures	Pilots Head		30	32	30	32	33	35	30	28	28	28
	Pilots Hands		26	28	28	30	32	31	28	25	24	24
	Pilots Feet		22	25	22	30	31	26	22	19	18	18
	Navs. Hands		26	29	30	30	30	32	30	29	28	28
	Navs. Feet		24	25	27	28	28	29	29	28	28	28
	B.A.'s Hands		26	30	30	31	32	33	33	33	32	32
	B.A.'s Feet		23	27	27	27	28	29	28	28	27	27
Average Cabin Temp.		25	28	28	30	31	31	28	27	26	26	
Accumulators		20	22	24	25	26	28	28	28	28	28	
Gyro Insts.		22	23	24	25	26	28	25	23	22	22	
Radio		22	22	24	25	26	28	28	27	25	25	
True O.d.T.		15	15	13	12	12	12	12	12	12	12	
% R.H. in Cabin												
Remarks	<div style="display: flex; justify-content: space-between;"> (--- Cold Air ---) (--- Hot Air ---) (--- Cold Air ---) </div> <p>Cloud. 6/10 at 1700' I.C.A.N. Pilot felt cool at 1900 hours. Observer comfortable throughout flight.</p>											

Canberra WD, 954

Trial made at Boscombe Down on 9.6.52

Start up 1100 hrs.

Taxi 1101-1107 hrs.

Take-off 1108 hrs.

I.A.S. 325 knots

Altitude 1500 ft. I.C.A.N

Outside R.H. 98%

Local Time		1100	1107	1110	1115	1120	1125	1130	1135	1140	1145	1150
Engine	Port	1800	1700	5700	5400	6400	6400	6500	6500	6500	5600	
R.P.M.	Stbd.	1900	2200	5700	5500	6400	6400	6500	6500	6500	5600	
Cabin Temp.	Inlet		20	10	0	0	0	0				
	Outlet		30	30	22	22	22	20				
Engine Outlet Temp.	Port			225	190	190	180	190				
	Stbd.			220	190	190	180	190				
Engine Outlet Press.	Port		5	70	45	45	45	45				
	Stbd.		10	70	45	45	45	45				
Turbine Temp.	Inlet		20	30	30	30	30	30				
	Outlet		20	0	0	0	0	0				
Turbine Press.	Inlet		1	50	40	40	38	40				
	Outlet		1/2	52	102	10	10 1/2	11				
Compressor Press.	Inlet		2	30	28	28	27	29				
	Outlet		2	50	40	40	40	42				
Compressor Temp.	Inlet		25	40	50	50	50	50				
	Outlet			100	90	90	90	90				
Primary Charge Temp.	Inlet											
	Outlet											
Air Temp. at Primary Heat Exch.	Inlet		35	40	55	50	50	50				
	Outlet		15	20	25	25	25	25				
Air Temp.-Outlet Sec.Ht.Ex			20	30	40	40	40	40				
Air Press-Intake Prim.Ht.Ex. Kts.				50	215	250	190	240				
Press.Diff.A/C Prim.Ht.Ex. kts.				42	175	220	150	220				
D.F.V. Outlet Temp.												
Venturi C.A.U. Press.				8	3	4	2 1/2	3				
Primary Charge Inlet Press.			3	60	35	35	33	35				
Pressure Ratio			1	3.25	2.2	2.25	2.1	2.15				
Mass Flow. lbs/min.				21	17.7	17.7	17	17.7				
C.A.U. R.P.I.				5100	4600	4600	4600	4600				
Cabin Temperatures	Pilots Head	49	48	35	28	23	22	22	32	37	39	39
	Pilots Hands	37	36	30	25	23	22	22	24	27	28	28
	Pilots Feet	23	23	18	17	17	16	16	20	21	22	22
	Navs. Hands	30	34	33	39	38	38	38	29	29	29	29
	Navs. Feet	22	23	26	25	25	24	24	24	24	24	24
	B.A's Hands	27	27	30	30	30	29	29	29	30	30	30
	B.A's Feet	27	25	27	26	26	25	25	26	26	26	26
	Average Cabin Temp.	31	31	29	26	25	24	24	24	26	28	28
Accumulators	17	17	20	20	24	24	24	24	24	25	25	25
Gyro Insts.	30	30	28	22	20	20	20	20	20	20	20	20
Radio	20	20	21	22	24	24	24	24	24	24	24	24
True O.A.T.	13	13	11	10	10	10	10	10	10	10	10	10
% R.H. in Cabin												
Remarks	Cocks Off ← Air fully cold. → Cocks off No Ventilation. → Cloud 10/10 at 1700' I.C.A.N. Pilot felt comfortable throughout flight Observer felt comfortable throughout flight.											

Wanborra WD. 954

Trial made at Boscombe Down on 9.6.52

Start up 1448 hrs.

Taxi 1449-1451 hrs.

Take-off 1452 hrs.

I.A.S. 485 knots.

Altitude 1500 ft. I.C.A.N

Outside R.H. 96%

Local Time		1447	1451	1500	1505	1510	1515	1520	1525	1530
Engine	Port		21.20	7300	7350	7300	7300	7350	7200	6600
R.P.M.	Stbd.		2340	7300	7400	7350	7350	7350	7200	6500
Cabin	Inlet	20	18	35	60+	2	0	0	0	0
Temp.	Outlet	32	35	30	40+	35	30	30	30	30
Engine	Port		50	230	250	250	250	250	250	250
Outlet	Stbd.		55	230	250	250	250	250	250	200
Temp.										
Engine	Port		6	75	82	80	80	80	75	50
Outlet	Stbd.		5	75	85	80	80	80	75	47
Press.										
Turbine	Inlet	25	25			50	50	50	50	40
Temp.	Outlet	25	21			0	0	0	0	0
Turbine	Inlet	0	1			40	40	39	37	44
Press.	Outlet	$\frac{1}{2}$	$\frac{1}{2}$			$1\frac{1}{2}$	$1\frac{1}{2}$	$1\frac{1}{2}$	2	$4\frac{1}{2}$
Compressor	Inlet		2			20	21	21	20	27
Press.	Outlet		$2\frac{1}{2}$			40	40	40	38	49
Compressor	Inlet		30			70	65	65	70	60
Temp.	Outlet					125	120	120	125	110
Primary	Inlet									
Charge	Outlet					70	70	70	70	70
Temp.										
Air Temp. at	Inlet	25	35			70	65	65	70	60
Primary	Outlet	28	23			40	40	40	40	30
Heat Exch.										
Air Temp.-Outlet Sec.Ht.Ex.		20	25			60	60	60	60	55
Air Press.-Intake Prim.Ht.Ex.Kts.						235	240	220	230	200
Press. Diff.A/c Prim. Ht. Ex. kts.						225	200	210	220	170
C.F.V. Outlet Temp.						175	160	140	125	120
Venturi C.A.U. Press.						6	6	6	5	6
Primary Charge Inlet Press			$2\frac{1}{2}$			73	73	71	69	35
Pressure Ratio		1	1			3.5	3.5	3.4	3.2	3.2
Mass Flow lbs/min.						18.2	18.2	17.8	16.3	18.8
C.A.U. R.P.H.						49000	49000	49000	49000	46500
Cabin Temperatures	Pilots Head	45	49	44	48	41	37	35	32	32
	Pilots Hands	35	40	36	44	39	35	34	32	32
	Pilots Feet	26	30	32	38	29	25	24	24	24
	Navs Hands	33	36	37	40	40	39	38	38	38
	Navs Feet	26	30	30	33	33	34	34	34	34
	B.A.'s Hands	30	34	36	38	40	40	40	40	40
	B.A.'s Feet	27	30	32	34	37	35	35	35	35
	Average Cabin Temp.	32	35	35	39	37	35	34	34	34
Accumulators	15	20	24	30	35	39	40	40	40	
Gyro Insts.	31	35	33	38	36	32	30	30	30	
Radio	19	20	24	34	35	37	36	36	36	
True O.A.T.	75	13	12	12	12	12	12	12	12	
% R.H. in Cabin										
Remarks	(Cold Air) ← Hot Air (← Gold Air →) Cloud 9/10 at 1700' I.C.A.N. Pilot, comfortable throughout flight. Observer, too warm most of flight.									

FIG. 20

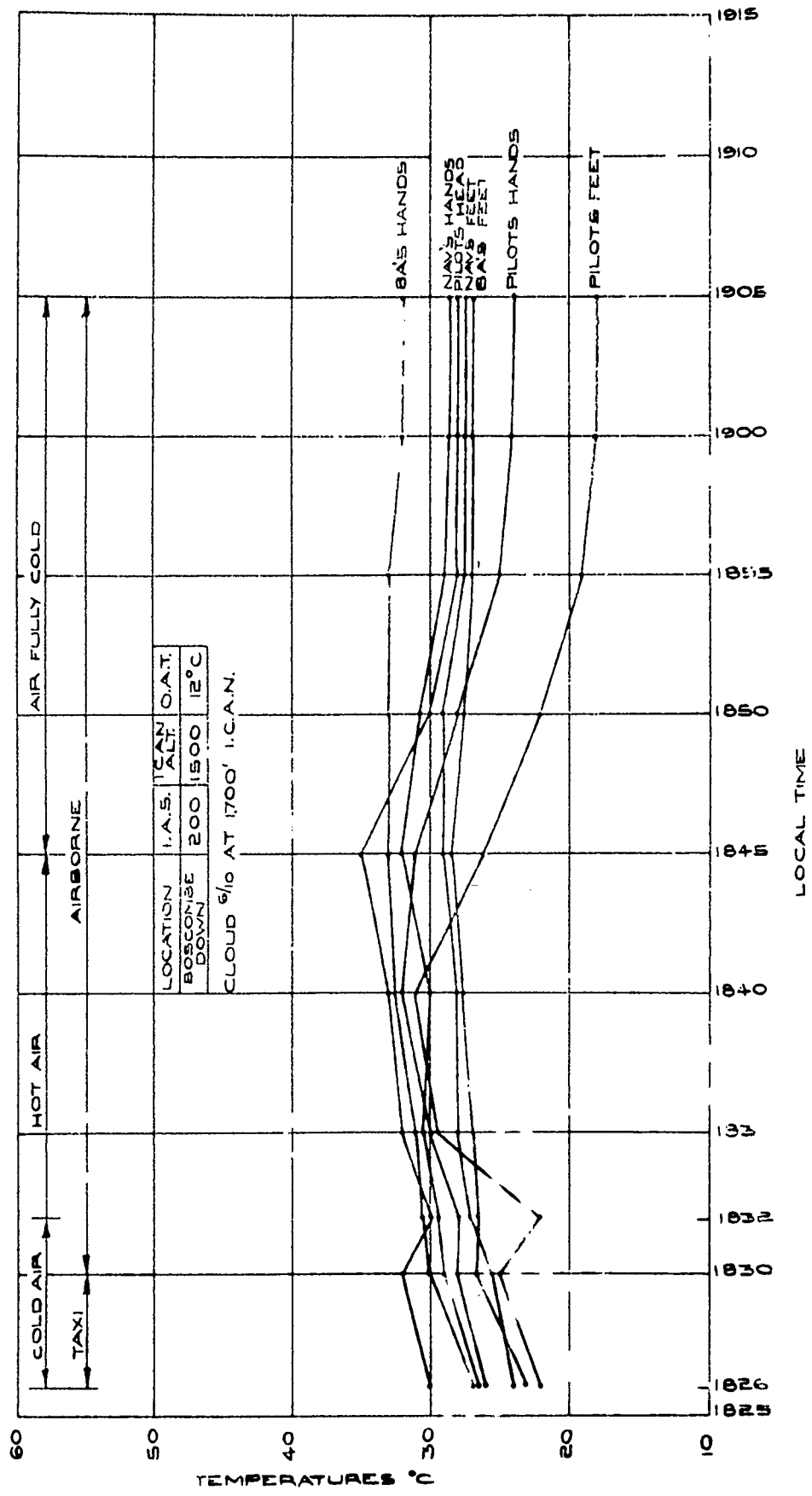

CABIN TEMPERATURES - TEMPERATE SUMMER
I.A.S. 200 KNOTS.

FIG. 2

SK. N°A. 4781 22nd PART OF REPORT NO. 8.A.E.E. / 861/1 CANBERRA WD. 954 TR. M. S. CH. W.P. WHITE APP. - (6/16)

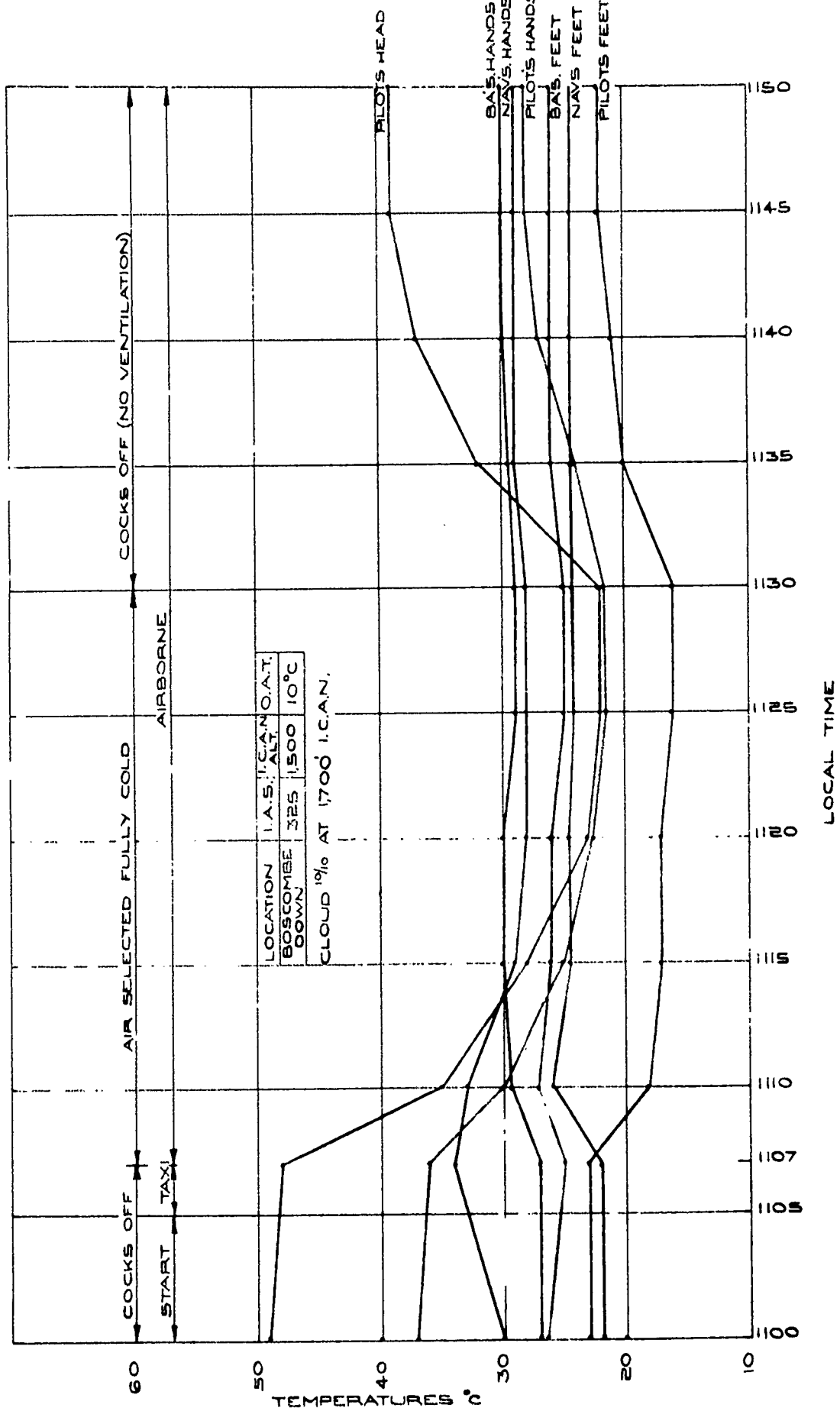

CABIN TEMPERATURES - TEMPERATE SUMMER
I.A.S. 325 KNOTS.

FIG. 22

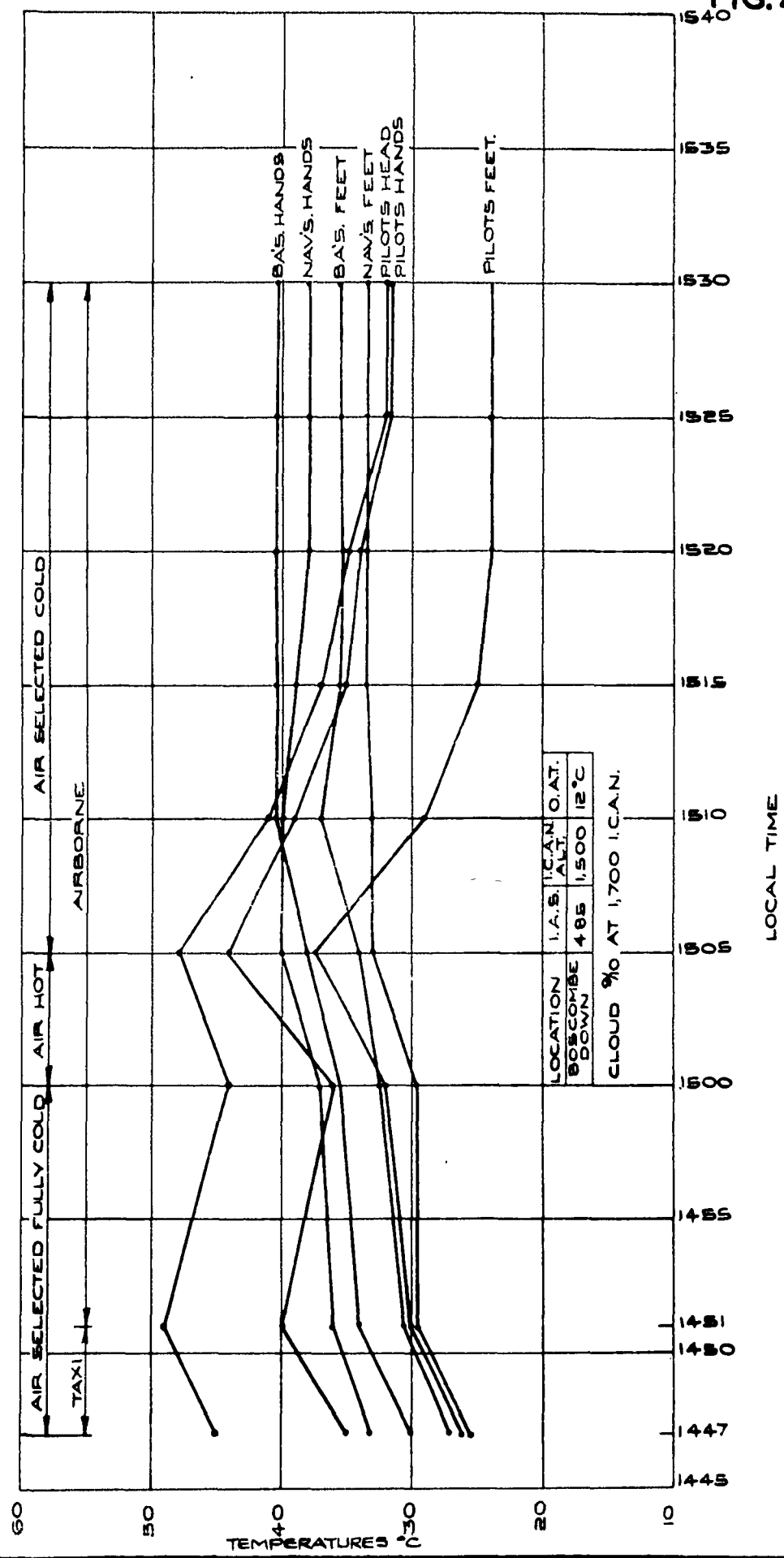

CABIN TEMPERATURE-TEMPERATE SUMMER I.A.S. 485 KNOTS.

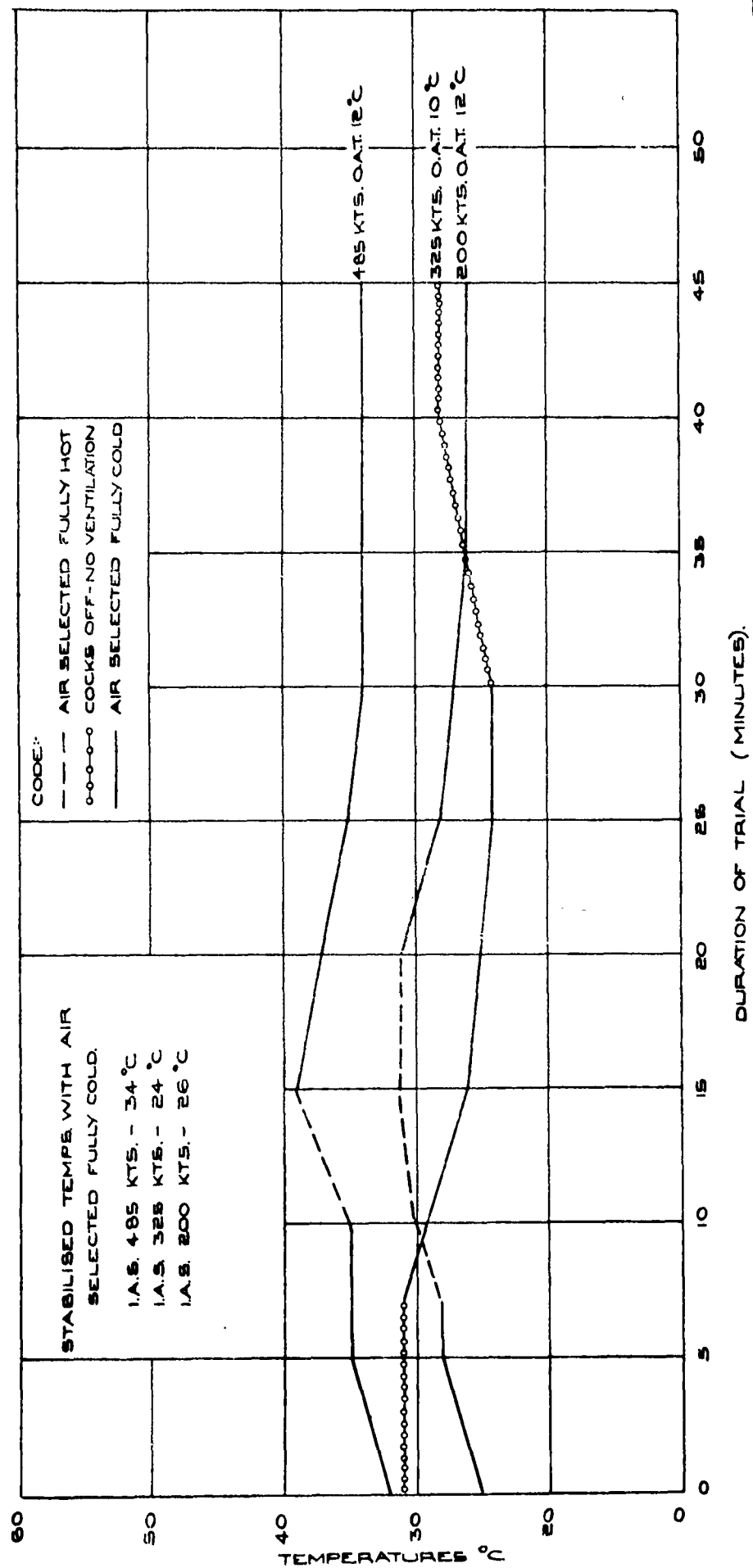

**AVERAGE CABIN TEMPERATURES
TEMPERATE SUMMER.**

FIG. 23

Cabin Temperatures during Transit from U.K. to Wadi-Scidna

Canberra V. D. 954

5th July, 1952

Flight Leg	Local Time	Cabin Temperatures.							Average Cabin Temperature	Gyro Inst's.	Accumulators	Radio	True O.A.P.	I.A.S. Knots	Altitude	P.M.	Remarks
		Pilots Head	Pilots Hands	Pilots Feet	Navs. Hands	Navs. Feet	B.A.'s Hands	B.A.'s Feet									
Boscombe Down to Castel Benito	0930	32	24	24	28	29	30	29	28	15	4	4	-56	240	40,000	7200	First reading after taking off at 0900 hrs.
	1000	30	20	20	22	27	18	24	23	10	0	-5	-59	225	41,000	7100	Pilot and Navigator Comfortable throughout Flight.
	1030	32	20	24	20	16	24	17	22	10	-5	-2	-57	220	42,000	7100	
	1100	38	24	25	22	18	28	14	24	12	-5	2	-56	220	43,000	7100	
	1130	35	25	30	22	18	28	15	24	17	-5	4	-54	220	43,000	7100	Last reading before landing at 1200 hrs.
Aircraft parked at Castel Benito for 1 ¹ hours during re-fuelling.																	
Castel Benito to Wadi Scidna	1345	41	34	34	32	35	40	35	36	26	23	18	-55	217	40,000	7400	First reading after taking off at 1315 hrs.
	1415	32	27	24	22	26	30	24	26	12	10	16	-56	235	40,000	7200	Pilot and Navigator comfortable throughout Flight.
	1445	26	18	21	15	18	22	20	20	10	7	2	-57	230	41,000	7200	
	1515	28	13	25	14	14	22	15	20	10	0	4	-57	225	42,000	7100	
	1545	30	20	35	22	15	27	18	24	24	20	2	12	-33	250	30,000	7400
1615	32	22	38	26	16	30	20	26	26	22	4	15	-33	250	30,000	7400	

Note - All temperatures are in °C
Aircraft above all cloud throughout flights

SK. No. A4784 22nd PART. OF REPORT No. A. E. E. / 861/1 CANBERIA WD 954 TR. S. M. CH. W.P. WHITE APP. - G. Cul for Sof E 20. 7. 53

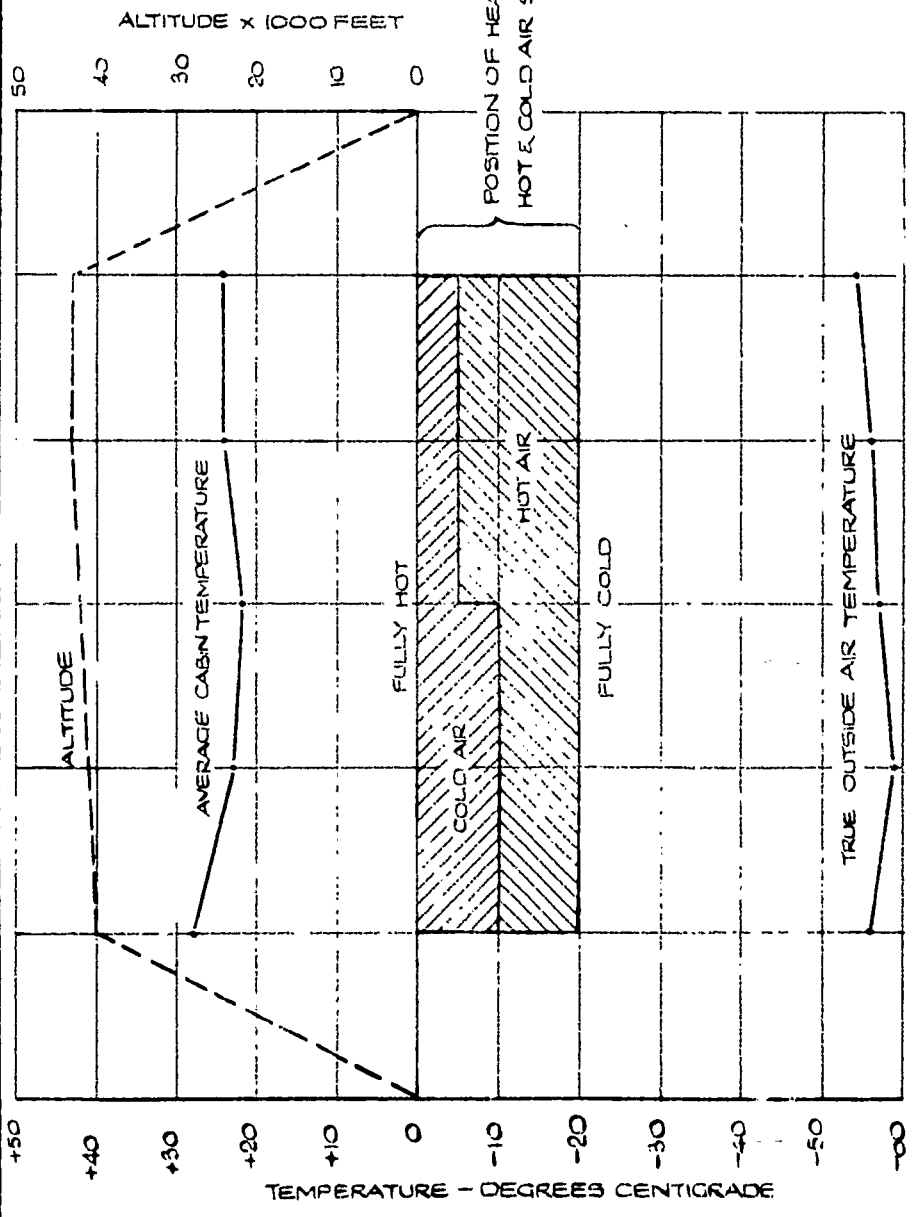

0930	0930	1000	1030	1100	1130	1200
TAKE-OFF	FIRST	LOCAL TIME			LAST	LAND. AT
8' DOWN	READING				READING	C' BENITO

FIG. 25.

CABIN TEMPERATURES IN TRANSIT - BOSCOMBE DOWN TO CASTEL BENITO.

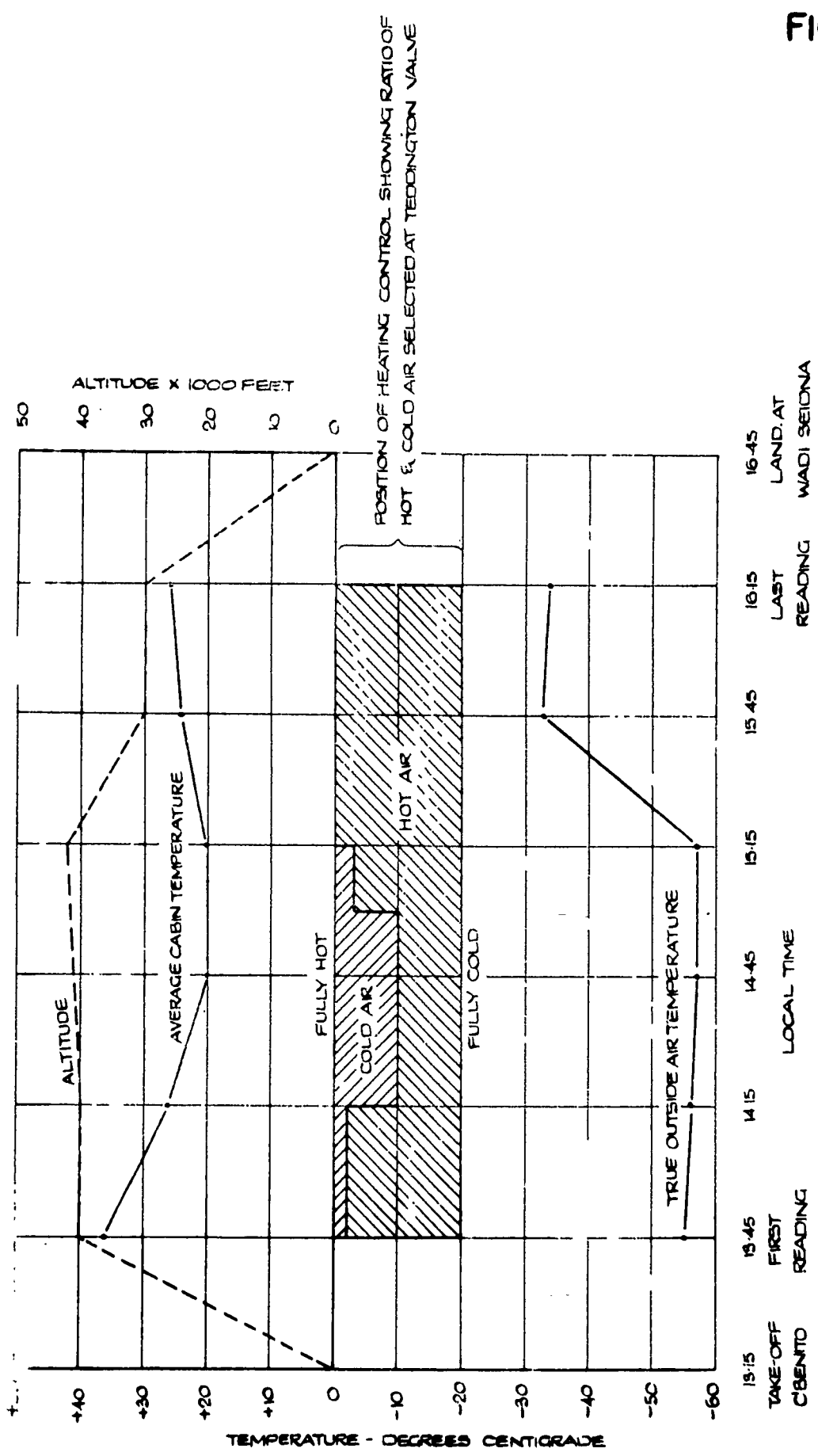

FIG.26.

CABIN TEMPERATURES IN TRANSIT- CASTEL BENITO TO WADI SEIDNA.

aberra WD. 954

Trial made at Khartoum on 24.7.52

Start Up 1359 hrs.

Taxi 14.00-14.04 hrs.

Take-off 14.05 hrs.

C.A.S. 200 knots

Altitude 3000 ft. I.C.A.N

Outside R.H. 40%

Local Time		1355	14.02	14.07	14.10	14.15	14.20	14.25	14.30
Engine R.P.M.	Port		2900	7800	5800	6200	6200	6200	6200
	Stbd.		3200	7700	5700	6200	6200	6200	6200
Cabin Temp.	Inlet		45	30	12	10	10	10	10
	Outlet		50	45	40	35	35	35	35
Engine Outlet Temp.	Port		75	250	160	160	160	160	160
	Stbd		75	250	160	160	160	160	160
Engine Outlet Press.	Port		5	61	21	25	24	24	24
	Stbd		4	62	19	24	23	23	23
Turbine Temp.	Inlet		50	60	45	40	35	35	35
	Outlet		50	15	12	10	10	10	10
Turbine Press.	Inlet		0	39	14	19	19	19	19
	Outlet		1/2	2 1/2	3/4	1	1	1	1
Compressor Press.	Inlet		0	22	9	11	11	11	11
	Outlet		2	40	15	20	20	20	20
Compressor Temp.	Inlet		60	60	62	55	55	55	55
	Outlet		60	110	100	100	95	95	95
Primary Charge Temp.	Inlet		75	175	160	150	150	150	150
	Outlet		60	85	60	50	52	52	52
Air Temp. at Primary Heat Exch.	Inlet		52	55	40	40	39	38	35
	Outlet		50	60	60	60	60	60	60
Air Temp. - Outlet Sec. Ht. Ex.			50	60	60	60	60	60	60
Air Press. - Intake Prim. Ht. Ex. kts.				60	155	160	160	150	150
Press. Diff. A/c Prim. Ht. Ex. kts.				4.2	115	115	115	115	115
C.F.V. Outlet Temp.			160	60	60	60	60	60	60
Venturi C.A.U. Press.			0	6	1	2	2	2	2
Primary Charge Inlet Press.			1	55	12	15	15	15	15
Pressure Ratio				2.7	1.95	2.25	2.25	2.25	2.25
Mass. Flow lbs/min.				16.2	8.7	10.3	10.4	10.4	10.4
C.A.U. R.P.M.				46700	40500	44000	42000	42000	42000
Cabin Temperatures	Pilots Head	46	43	53	51	50	50	49	49
	Pilots Hands	44	47	50	51	50	50	50	50
	Pilots Feet	42	45	46	44	42	41	40	40
	Navs. Hands	40	44	47	47	47	47	46	46
	Navs. Feet	39	42	45	45	45	45	44	45
	B.A.'s Hands.	42	46	50	50	49	48	48	48
	B.A.'s Feet	42	43	43	43	44	44	44	44
	Average Cabin Temp	42	45	48	47	47	47	46	46
Accumulators	42	43	44	44	43	42	41	41	
Gyro Insts.	42	42	44	44	43	42	42	42	
Radio	42	42	44	44	43	42	42	42	
True O.A.T.	39	39	32	31	32	31	31	31	
% R.H. in Cabin	69	66	66	66	64	62	62	62	

Remarks

← Air fully cold - Ram air off. →

Cloud: Nil.
 Cabin comfortable on entry whilst parked under awning.
 Hot whilst taxiing - crew perspired freely.
 Comfortable in flight.

Sanberra WD, 954

Trial made at Khartoum on 24.7.52

Start up 1051 hrs.

Taxi 1052 - 1102 hrs.

Take-off 1103 hrs.

I.A.S. 200 knots

Altitude 3000 ft. ICAN

Outside R.H. 40%

Local Time		1052	1056	1104	1110	1115	1120	1125	1130	1135	1140
Engine R.P.M.	Port										
	Stbd.										
Cabin Temp.	Inlet										
	Outlet										
Engine Outlet Temp.	Port										
	Stbd.										
Engine Outlet Press	Port										
	Stbd.										
Turbine Temp.	Inlet										
	Outlet										
Turbine Press.	Inlet										
	Outlet										
Compressor Press.	Inlet										
	Outlet										
Compressor Temp.	Inlet										
	Outlet										
Primary Charge Temp.	Inlet										
	Outlet										
Air Temp. at Primary Heat Ech.	Inlet										
	Outlet										
Air Temp. - Outlet S.c.Ht. Ex.											
Air Press. - Intake Prim. Et. Ex. kts.											
Press. Diff. A/c Prim. Ht. Ex. kts.											
C.F.V. Outlet Temp.											
Venturi C.A.U. Press.											
Primary charge inlet press.											
Pressure Ratio											
Mass Flow lbs/min.											
C.A.U. R.P.M.											
Cabin Temperatures	Pilots Head	42	47	52	55	50	57	57	57	52	50
	Pilots Hands	43	44	48	50	51	52	52	52	47	46
	Pilots Feet	40	43	45	46	46	46	46	46	40	38
	Navs Hands	40	40	42	43	45	48	49	49	40	43
	Navs Feet	36	37	40	41	43	45	46	47	44	42
	B.A's Hands	42	42	44	45	45	46	48	49	47	47
	B.A's Feet	37	40	42	43	45	47	48	48	45	43
	Average Cabin Temp.	41	43	45	47	48	49	50	50	46	44
Accumulators	35	36	40	42	43	44	46	46	46	46	
Gyro Insts.	36	38	41	42	42	42	43	43	42	42	
Radio	34	35	38	40	42	42	42	42	42	42	
True O.A.T.	35	36	33	30	31	30	30	30	30	30	
% R.H. in Cabin.	76	78	80	82	83	83	83	83			

AUTO OBSERVER NOT USED

Remarks

← Ram Air only - Cold Air Off → *Cold On →

Cloud Nil.

Cabin comfortable on entry whilst parked under awning. Crew perspired freely when awning was removed for taxiing. Continued heavy perspiration throughout flight. Conditions uncomfortable and tiring. Immediate relief when cold air selected at 1130 hrs.

Canberra WD, 954

Trial made at Khartoum on 24.7.52

Start up 1159 hrs.

Taxi 1200 - 1204 hrs.

Take-off 1205 hrs.

I.A.S. 325 knots

Altitude 3000ft, ICAN

Outside R.H. 40%

Local Time		1155	1202	1210	1215	1220	1225	1230	1235
Engine R.P.M.	Port		2000	6700	6750	6700	6900		
	Stbd		2200	6700	6750	6700	6800		
Cabin Temp.	Inlet		1.0	1.0	5	5	7		
	Outlet		4.0	3.5	3.5	3.5	3.0		
Engine Outlet Temp.	Port		4.0	220	225	200	200		
	Stbd		4.0	220	225	200	200		
Engine Outlet Press.	Port		4	4.5	4.5	3.2	3.5		
	Stbd		4	4.4	4.5	3.2	3.5		
Turbine Temp.	Inlet		50	50	50	50	50		
	Outlet		50	5	5	5	5		
Turbine Press.	Inlet		0	3.5	3.5	2.9	3.1		
	Outlet		1/2	2 1/2	2 1/2	2	2		
Compressor Press.	Inlet		0	21	20	17	18		
	Outlet		2	37	36	30	32		
Compressor Temp.	Inlet		50	70	70	50	70		
	Outlet		60	130	130	120	125		
Primary Charge Temp.	Inlet		75	200	200	190	190		
	Outlet		52	70	70	70	70		
Air Temp. at Primary Heat Exch.	Inlet		40	43	45	45	45		
	Outlet		42	70	70	70	70		
Air Temp-Outlet Sec. Ht. Ex.			50	70	80	70	70		
Air Press-Intake Prim. Ht. Ex. kts.				180	190	190	190		
Press. Diff. A/c Prim. Ht. Ex. kts.				150	160	150	150		
C.A.U. Outlet Temp.			65	60	55	55	55		
Venturi C.A.U. Press.				5	5	3 1/2	4		
Primary Charge Inlet Press.			1 1/2	3.4	3.5	2.3	2.5		
Pressure Ratio				3.1	3.1	2.76	2.9		
Mass Flow lbs/min.				15.2	15.2	13.3	14		
C.A.U. R.P.M.			20750	50600	50600	55000	49000		
Cabin Temperatures	Pilots Head	4.0	4.3	4.6	4.5	4.2	4.0	4.0	4.0
	Pilots Hands	4.0	4.4	4.5	4.5	4.5	4.5	4.5	4.5
	Pilots Feet	3.8	4.1	4.2	4.0	3.8	3.6	3.5	3.5
	Navs Hands	3.4	3.6	4.3	4.4	4.2	4.2	4.2	4.2
	Navs Feet	3.3	3.6	4.1	4.0	4.0	4.0	4.0	4.0
	B.A.'s Hands	4.0	4.2	4.3	4.5	4.4	4.3	4.2	4.2
	B.A.'s Feet	3.8	4.0	4.5	4.4	4.4	4.4	4.2	4.2
	Average Cabin Temp.		3.8	4.0	4.4	4.4	4.2	4.1	4.1
Accumulators		3.8	4.0	4.2	4.5	4.5	4.5	4.5	4.5
Gyro Insts		3.8	4.0	4.0	3.8	3.6	3.6	3.6	3.6
Radio		3.6	4.0	4.0	4.1	4.1	4.2	4.2	4.2
True O.A.T.		3.6	3.6	3.4	3.1	3.0	3.0	3.1	3.0
% R.H. in Cabin		74	68	70	69	65	65	64	64

Remarks

Air Fully Cold - Ram Air Off

Cloud Nil.
 Cabin comfortable on entry whilst under awning.
 Hot whilst taxiing - crew perspired freely.
 Comfortable during flight.

Combera WD, 954.

Trial made at Khartoum on 24.7.52

Fig. 30

Start up 1259 hrs.

Taxi 1300 - 1306 hrs.

Take-off 1307 hrs.

I.A.S. 325 knots

Altitude 3000ft. ICAN

Outside R.H. 40%

Local Time		1300	1305	1308	1310	1315	1320	1325	1330	1335
Engine R.P.M.	Port									
	Stbd.									
Cabin Temp.	Inlet									
	Outlet									
Engine Outlet Temp	Port									
	Stbd.									
Engine Outlet Press.	Port									
	Stbd.									
Turbine Temp.	Inlet									
	Outlet									
Turbine Press.	Inlet									
	Outlet									
Compressor Temp.	Inlet									
	Outlet									
Primary Charge Temp.	Inlet									
	Outlet									
Air Temp at Primary Heat Exch.	Inlet									
	Outlet									
Air Temp.-Outlet Sec.Ht. Ex.										
Air Press-Intake Prim.Ht.Ex. kts.										
Press.Diff.A/c Prim. Ht.Ex. kts.										
C.F.V. Outlet Temp.										
Venturi C.A.U. Press.										
Primary charge Inlet Press.										
Pressure Ratio										
Mass. Flow. lbs/min.										
C.A.U. R.P.M.										
Cabin Temperatures	Pilots Head	40	43	50	50	54	56	58	54	52
	Pilots Hands	40	45	47	49	49	49	49	45	44
	Pilots Feet	40	40	40	43	45	45	45	40	38
	Nav. Hands	35	40	45	47	48	49	50	47	45
	Navs. Feet	35	40	45	50	50	50	50	47	45
	B.A's Hands	40	43	46	50	51	51	51	49	48
	B.A's Feet	40	45	45	46	48	48	48	49	44
	Average Cabin Temp.	39	43	45	48	49	50	50	47	45
Accumulators		40	45	45	44	47	47	47	47	47
Gyro Insts.		39	40	42	44	44	44	44	44	44
Radio		37	42	42	42	43	43	43	43	43
True O.A.T.		37	36	34	31	32	31	31	31	31
% R.H. in Cabin		71	71	73	75	77	77	77	77	77

AUTO OBSERVER NOT USED

Remarks

← Ram Air only - Cold Air Off → (Cold On →)

Cloud Nil.
 Cabin comfortable on entry whilst parked under awning. Crew perspired freely when awning was removed for taxiing. Continued heavy perspiration throughout flight. Very hot and uncomfortable. Immediate relief felt when cold air selected at completion of test at 1325 hrs.

FIG. 3!

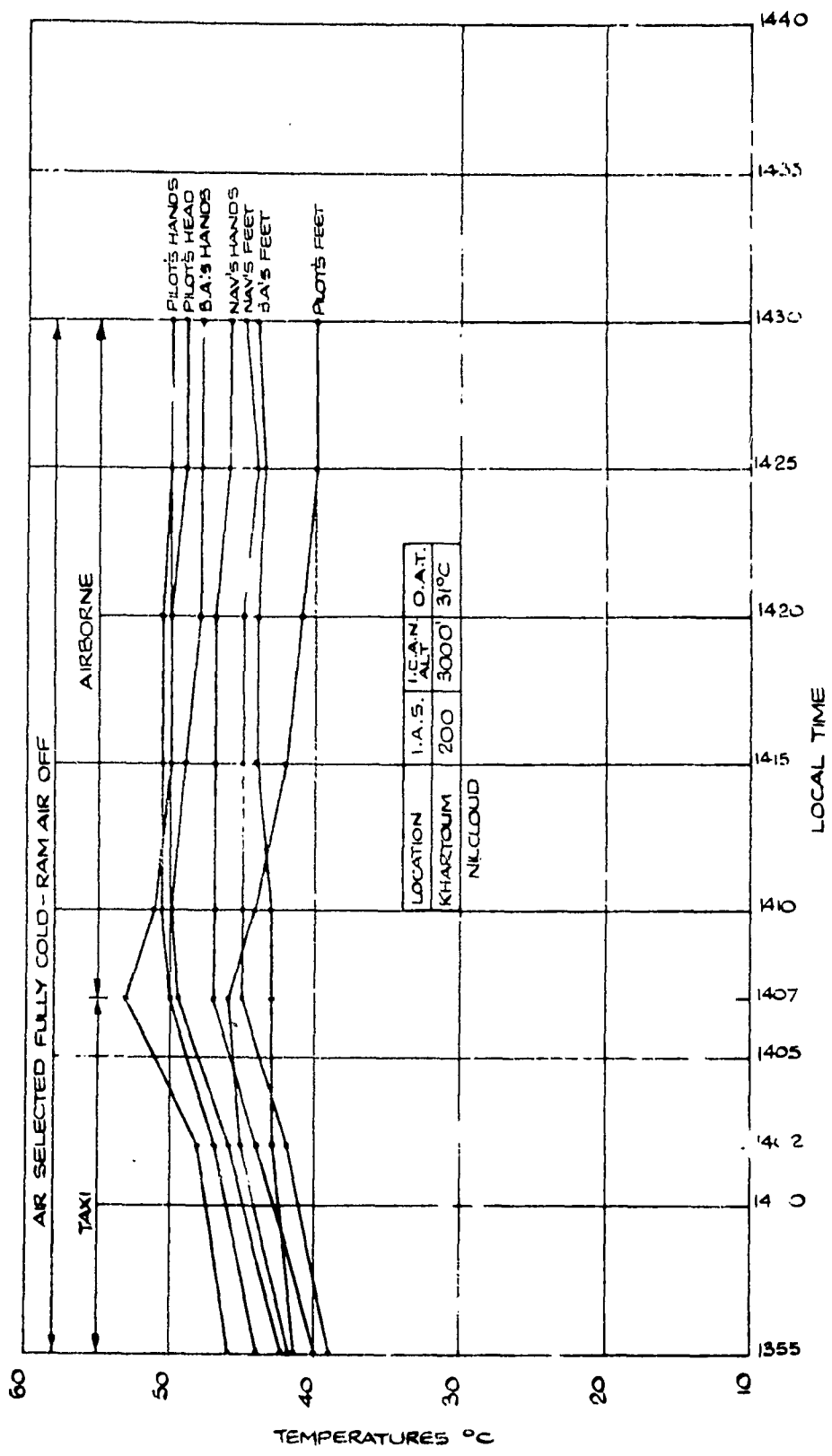

CABIN TEMPERATURES-TROPICAL SUMMER-I.A.S. 200KTS.

FIG.32.

SK.No A4787. 22nd PART OF REPORT NO A&A.EE. / 861/1. CANBERRA WP 954. TR. - M. CH. W.P. WHITE. APP. - G.L.B. for SofE 20.7.53

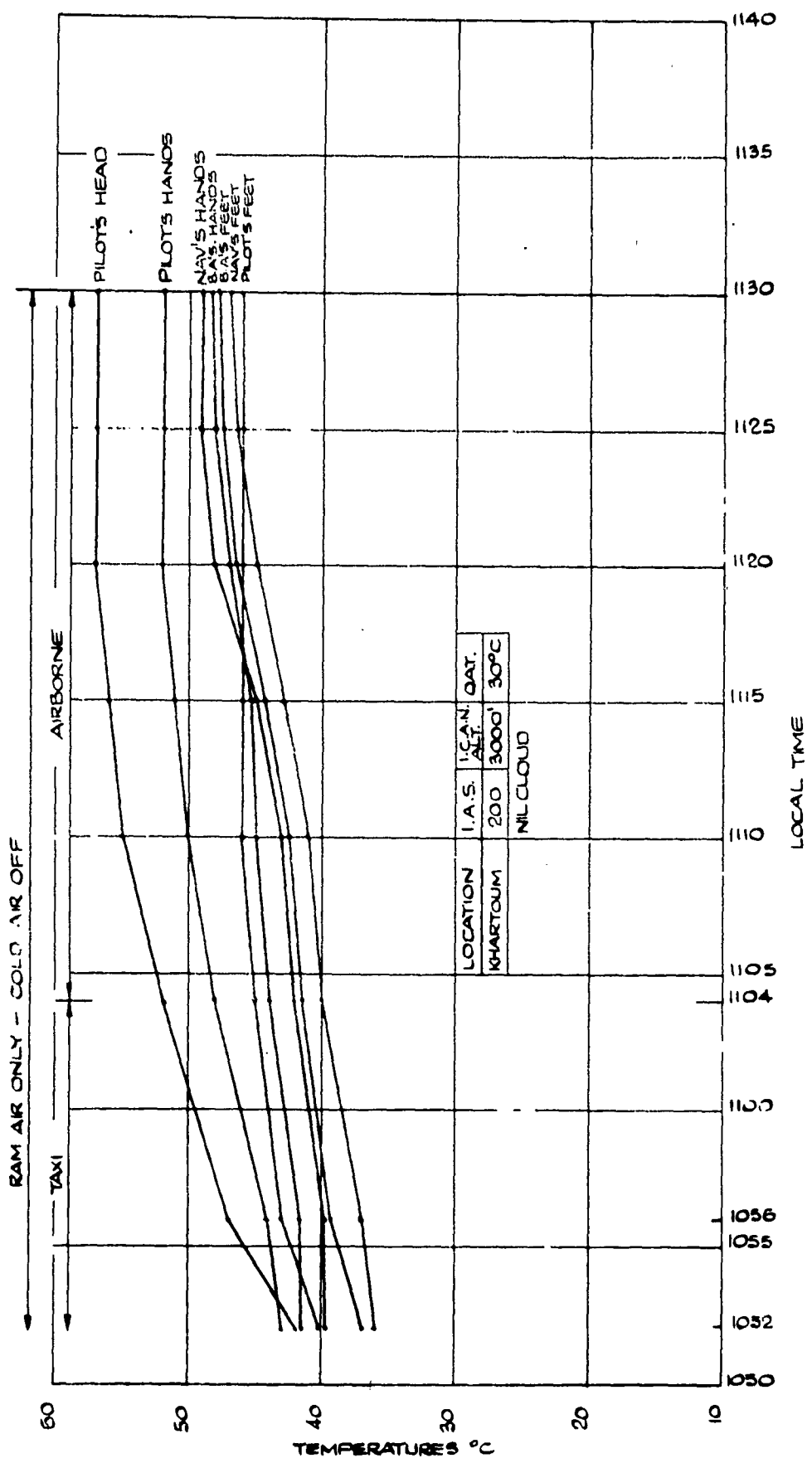

CABIN TEMPERATURES-TROPICAL SUMMER-I.A.S. 200 KTS.

FIG. 33.

SK NO. A. 4788 22ND PART OF REPORT NO. A. E. E. / 861/1 CANBERRA W.C. TR. S.M. CH. W.P. WHITE APP. (initials) for SoF E 20. 7. 53

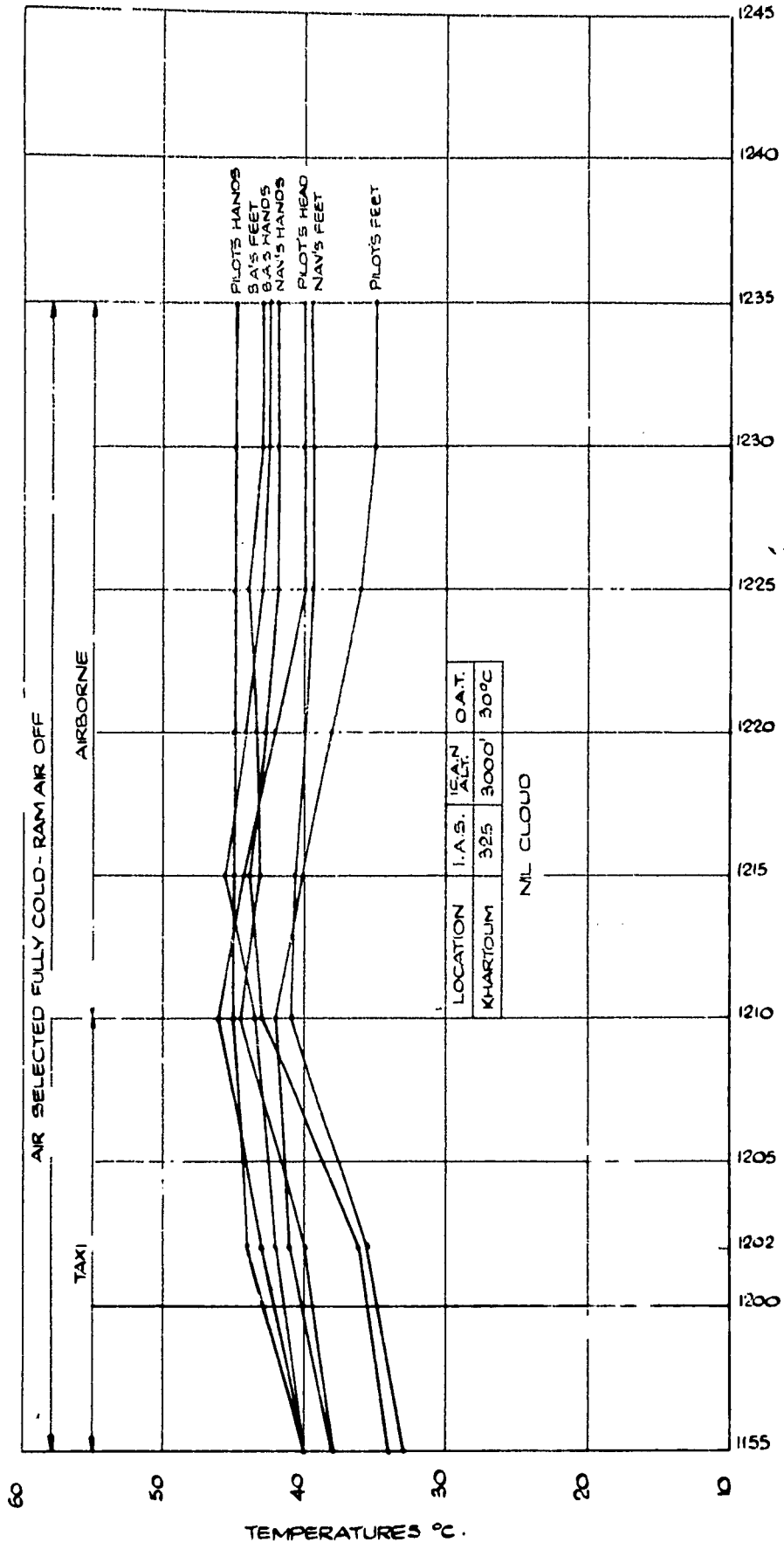

CABIN TEMPERATURES - TROPICAL SUMMER - I.A.S. 325 KTS.

FIG. 3₄₇

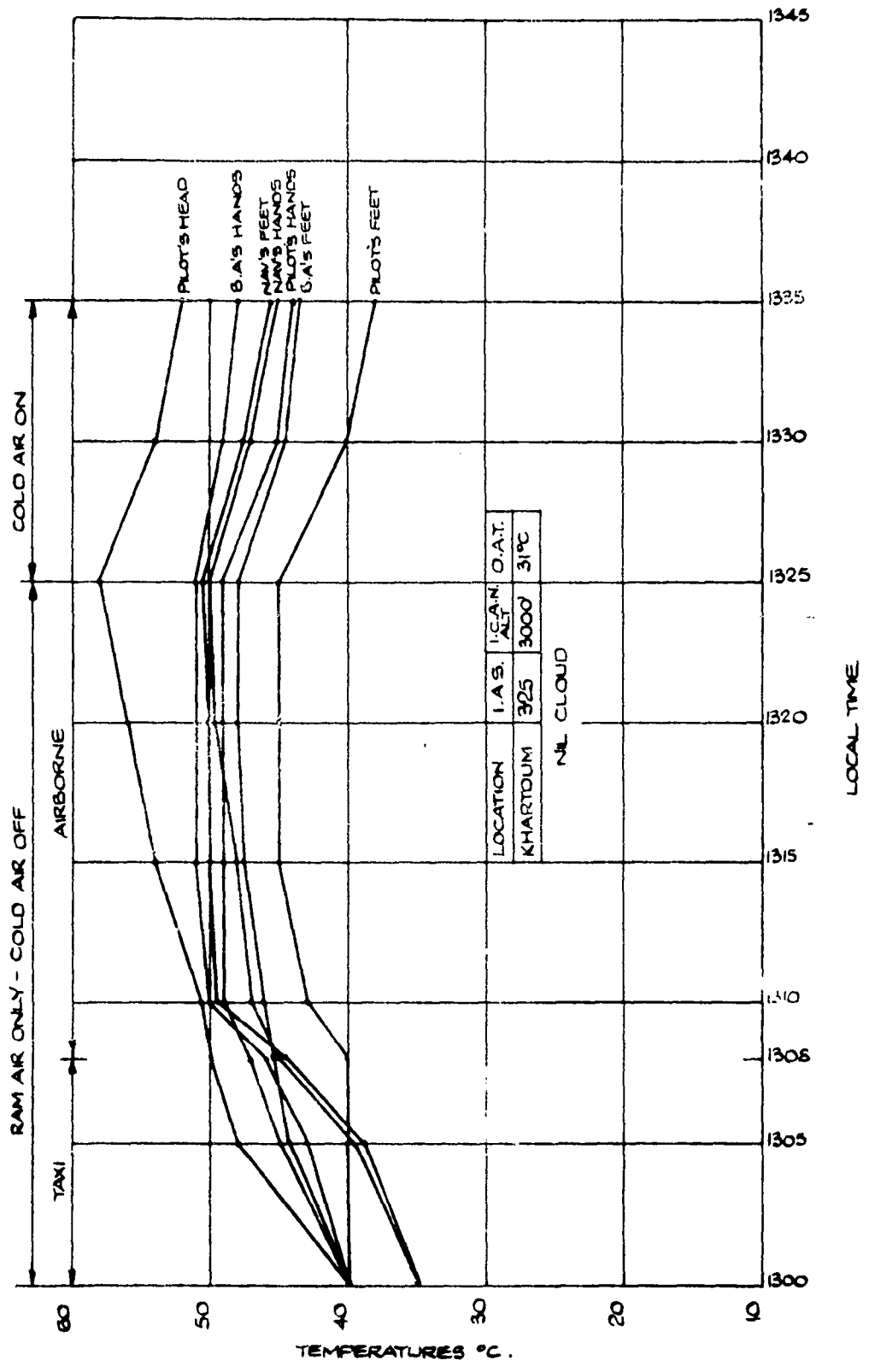

CABIN TEMPERATURES - TROPICAL SUMMER - I.A.S. 325 KTS.

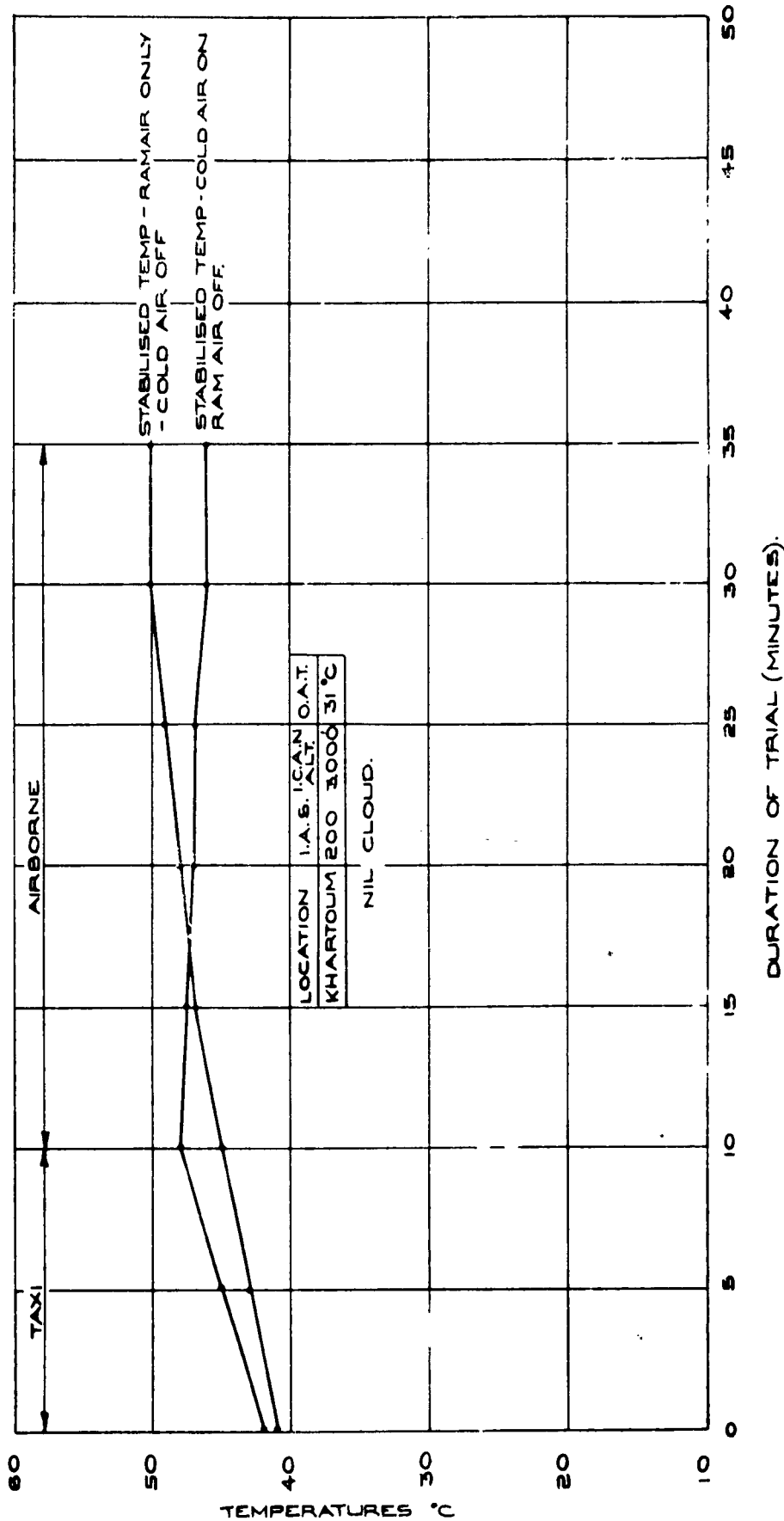
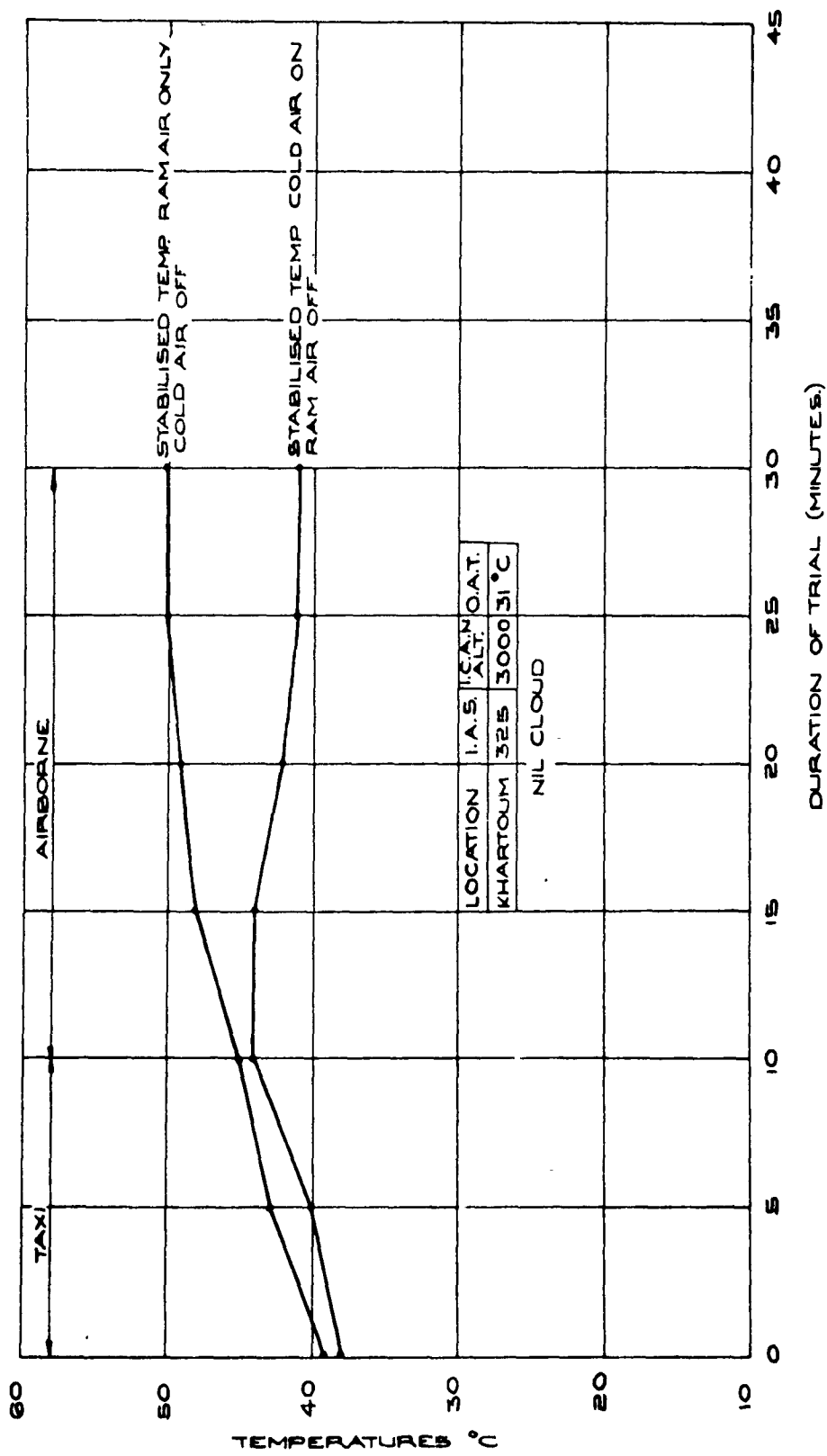

FIG. 35

AVERAGE CABIN TEMPERATURES-TROPICAL SUMMER - 200 KNOTS I.A.S.



AVERAGE CABIN TEMPERATURES-TROPICAL
SUMMER- 325 KNOTS I.A.S.

FIG. 36

Canberra WD. 954.

Trial made at Khartoum

Fig. 37

Start up 1811 hrs.

Taxi 1812 - 1816 hrs.

Take-off 1817 hrs.

I.A.S. 200 knots

Altitude 3000 ft. I.C.A.N.

Outside R.H. - $\frac{1}{2}$

Night Flying - No Solar Radiation

Local Time		1812	1815	1818	1820	1825	1830	1835	1840	1845	
Engine R.P.M.	Port		5000	7000	6850	5650	6500	5300	5900	5300	
	Stbd		5600	7000	6650	5600	6500	5300	5700	5700	
Cabin Temp.	Inlet		35	0	0	10	10	10	10	10	
	Outlet		35	35	35	35	35	35	35	35	
Engine Outlet Temp.	Port		120	240	225	140	170	165	150	165	
	Stbd		120	240	225	140	170	165	150	165	
Engine Outlet Press.	Port		12	4.5	4.4	18	25	23	21	24	
	Stbd		17	4.6	4.4	16	25	23	18	18	
Turbine Temp.	Inlet		35	4.5	5.5	10	35	4.5	4.5	4.5	
	Outlet		22	0	0	$\frac{1}{2}$	5	5	10	15	
Turbine Press.	Inlet		7	38	34	9	18	16	12	13	
	Outlet		$\frac{1}{2}$	2 $\frac{1}{2}$	1	$\frac{1}{2}$	1	1	$\frac{1}{2}$	$\frac{1}{2}$	
Compressor Press.	Inlet		5	23	20	10	10	10	7	8	
	Outlet		8	39	40	30	19	17	14	15	
Compressor Temp.	Inlet		40	75	70	70	55	55	55	55	
	Outlet		60	130	140	125	95	95	95	95	
Primary Charge Temp.	Inlet		90	210	210	150	155	154	140	100	
	Outlet		0	75	75	55	50	50	50	50	
Air Temp. at Primary Heat Exch ^r .	Inlet		35	40	45	40	35	35	40	35	
	Outlet		40	75	75	50	55	55	55	55	
Air Temp. - Outlet Sec. Ht. Ex.			40	75	75	55	50	50	50	50	
Air Press. - Intake Prim. Ht. Ex. kts			0	200	190	170	150	160	140	100	
Press. Diff. A/c Prim. Ht. Ex. kts			0	165	160	120	110	120	100	0	
C.A.U. Outlet Temp.									53	53	
Venturi C.A.U. Press.				5	4.5	$\frac{1}{2}$	1 $\frac{1}{2}$	1 $\frac{1}{2}$	1	1	
Primary Charge Inlet Press.			7	31	30	90	15	14	11	12	
Pressure Ratio			1.5	2.6	3.3	1.6	2.2	2.05	1.83	1.9	
Mass Flow lbs/min.			6.5	16.6	14.6	7.9	10	9.4	8.5	8.4	
C.A.U. R.P.M.			29500	49000	36400	42000	39500	40600	42100	42000	
Cabin Temperatures	Pilots Head	40	43	40	39	38	37	36	33	33	
	Pilots Hands	40	43	40	39	38	36	35	34	34	
	Pilots Feet	40	41	40	38	37	36	35	32	32	
	Navs Head	40	38	38	37	37	37	35	34	34	
	Navs Hands	40	38	38	37	37	36	36	34	34	
	Navs Feet	40	38	38	37	37	36	36	34	34	
	B.A.'s Head	41	44	41	40	39	37	36	33	33	
	B.A.'s Hands	41	44	41	40	39	38	37	36	36	
	B.A.'s Feet	41	44	41	40	39	38	37	36	36	
	Average Cabin Temp.		40	42	40	39	38	37	36	34	34
	Accumulators		40	41	39	39	39	39	39	39	39
	Gyro Insts		38	37	36	36	36	36	35	35	35
Radio		39	40	38	37	37	37	37	36	36	
True O.A.T.		34	33	29	29	28	27	27	27	27	
$\frac{1}{2}$ R.H. in Cabin		76	76	74	72	70	68	68	67	66	

Remarks

Air Fully Cold - Ref. Air Off

Cloud Nil.

Pilot and observer very comfortable throughout taxiing and flying.

Canberra WD.954

Trial made at Khartoum on 28.7.52

Fig. 38

Start up - hrs.

Taxi - hrs.

Take-off 1846 hrs.

I.A.S. 200 knots

Altitude 3000 ft. I.C.A.N.

Outside R.H. - %

Night Flying - No Solar Radiation

Local Time		1846	1850	1855	1900	1905
Engine	Port					
R.P.M.	Stbd					
Cabin	Inlet					
Temp.	Outlet					
Engine	Port					
Outlet	Stbd					
Temp.						
Engine	Port					
Outlet	Stbd					
Press.						
Turbine	Inlet					
Temp.	Outlet					
Turbine	Inlet					
Press.	Outlet					
Compressor	Inlet					
Press.	Outlet					
Compressor	Inlet					
Temp.	Outlet					
Primary	Inlet					
Charge	Outlet					
Temp.						
Air Temp. at	Inlet					
Primary	Outlet					
Heat Exch ^r .						
Air Temp.-Outlet Sec. Ht. Ex.						
Air Press.-Intake Prim. Ht.Ex. kts						
Press. Diff. A/c Prim. Ht. Ex. kts						
C.P.V. Outlet Temp.						
Venturi C.A.U. Press.						
Primary Charge Inlet Press.						
Pressure Ratio						
Mass Flow lbs/min.						
C.A.U. R.P.M.						
Cabin Temperatures	Pilots Head	42	41	41	40	41
	Pilots Hands	41	41	41	41	41
	Pilots Feet	40	40	40	41	41
	Navs Hands	37	42	41	41	41
	Navs Feet	47	42	40	40	40
	B.A's Hands	42	41	41	41	41
	B.A's Feet	43	41	40	40	40
	Average Cabin Temp.	42	41	41	41	41
Accumulators	44	47	44	44	44	
Gyro Insts	38	38	37	37	37	
Radio	38	38	38	38	38	
True O.A.T.	26	26	26	27	27	
% R.H. in Cabin	63	63	65	68	70	

P/O OBSERVER NOT USED

Remarks

← Ram Air Only - Cold Air Off →

Cloud Nil.

Pilot and Observer sweating profusely throughout flight. Very hot and uncomfortable. Cold air switched on at completion of trial at 1905 hrs, relief was immediate although aircraft temperature drop was only 2°C before landing at 1915 hours.

FIG. 39.

SR NSAA4792 29th PART OF REPORT NPAKAEI / 86/11 CANBERRA WO 954 1st O. S. M. I. CH. W. P. WHITE APP. *Black* For. S. O. F. E. 20.7.53

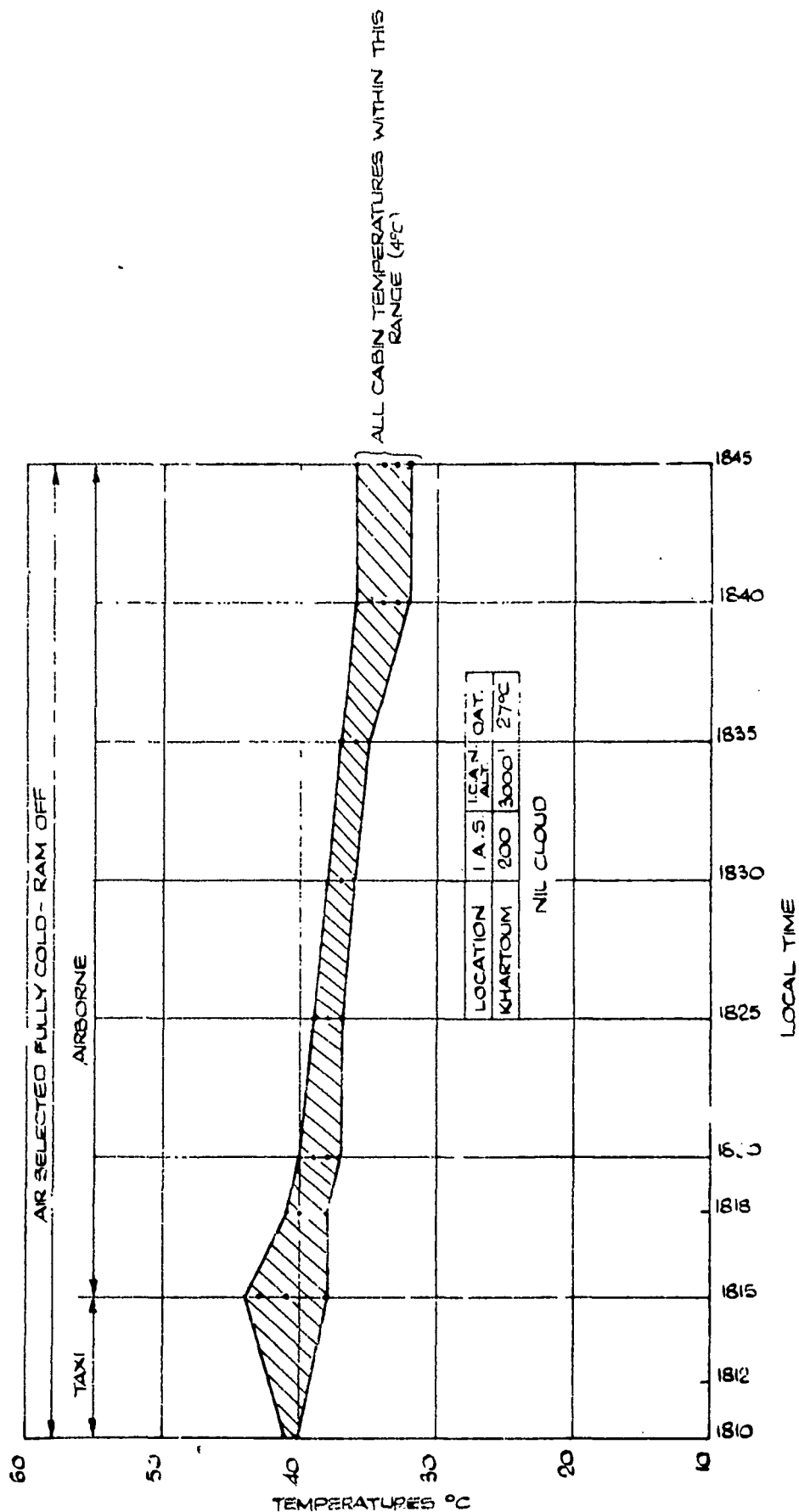

CABIN TEMPERATURES-TROPICAL SUMMER (NIGHT)
I.A.S. 200 KNOTS.

FIG.40.

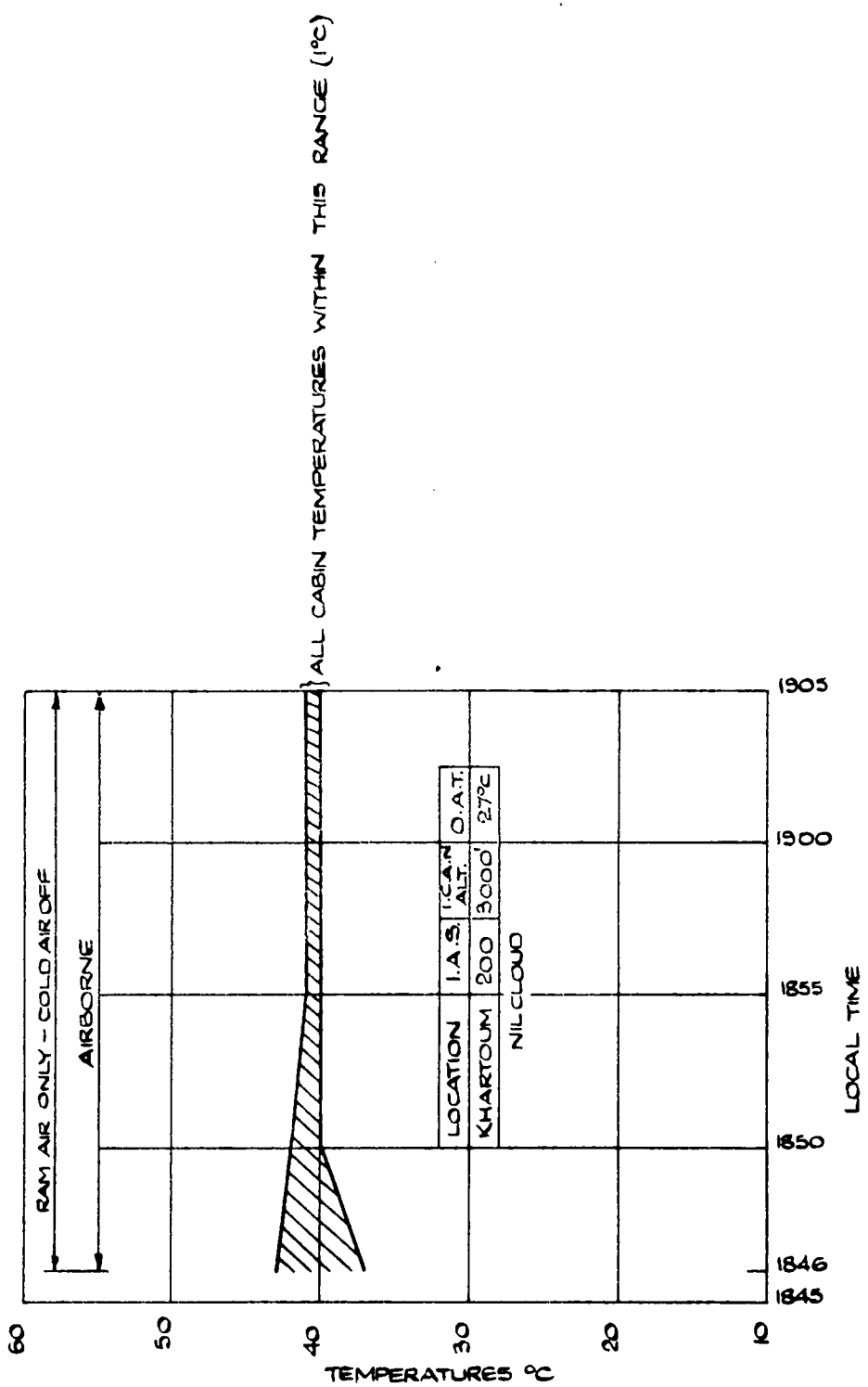

CABIN TEMPERATURES-TROPICAL SUMMER (NIGHT)
I.A.S. 200 KNOTS.

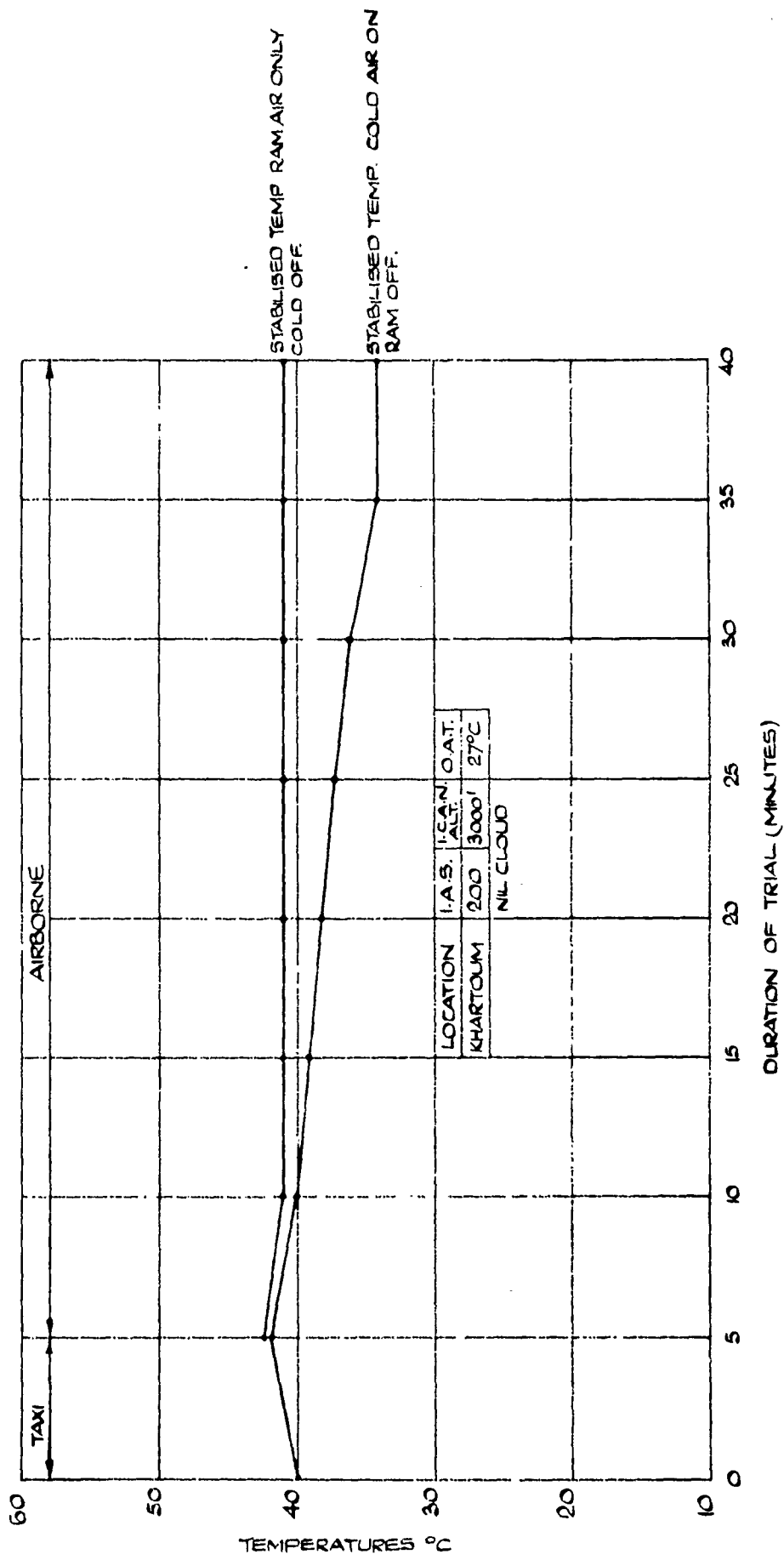

FIG. 41.

AVERAGE CABIN TEMPERATURE-TROPICAL SUMMER(NIGHT)
I.A.S. 200 KNOTS.

SK. N9A.4795 22ND PART OF REPORT N9A.A.E.E./86/11 CANBERRA WD 954 TR. S. M CH. W.P. WHITE APP. *Good* for Safe 20.7.53.

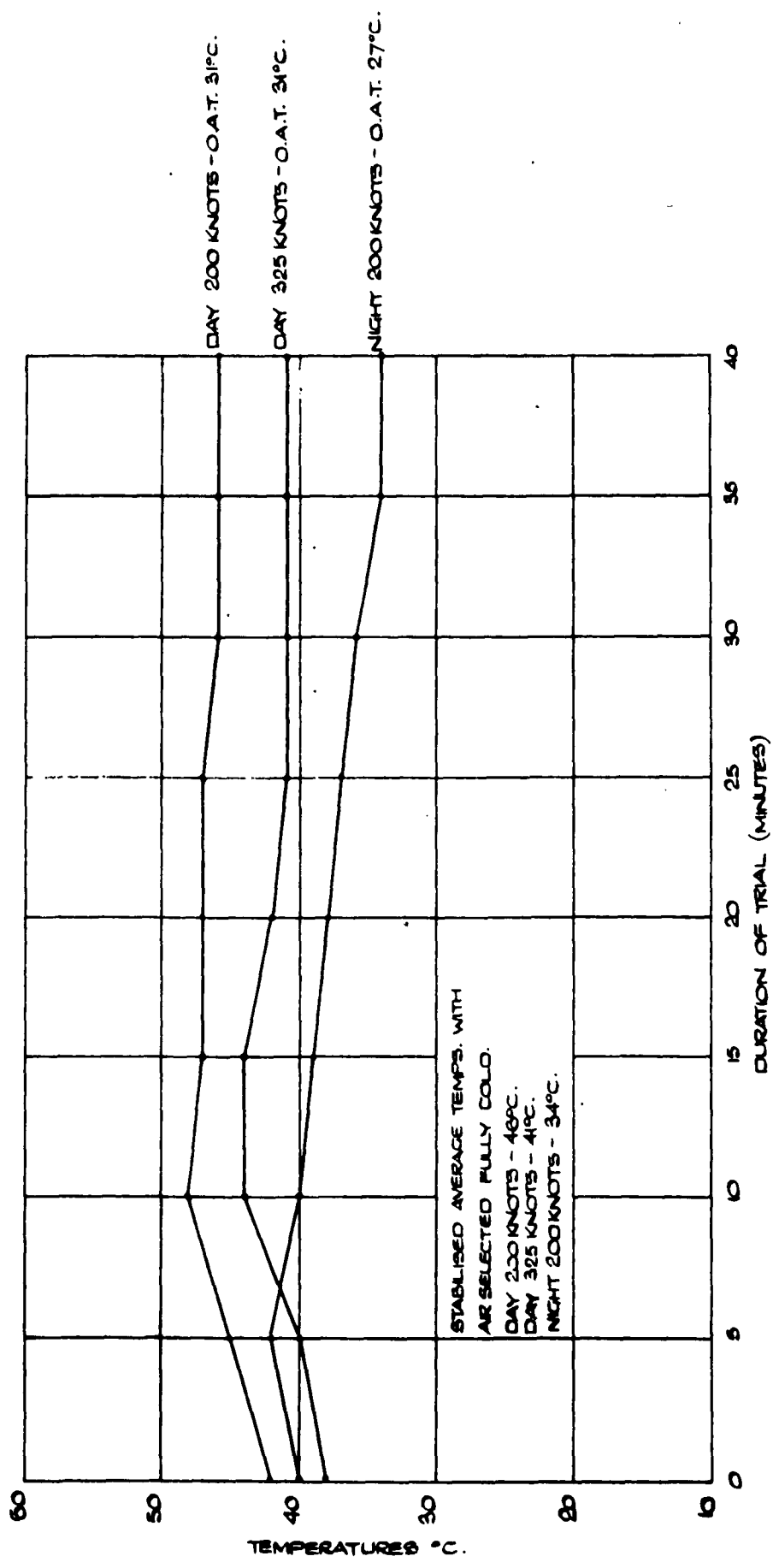
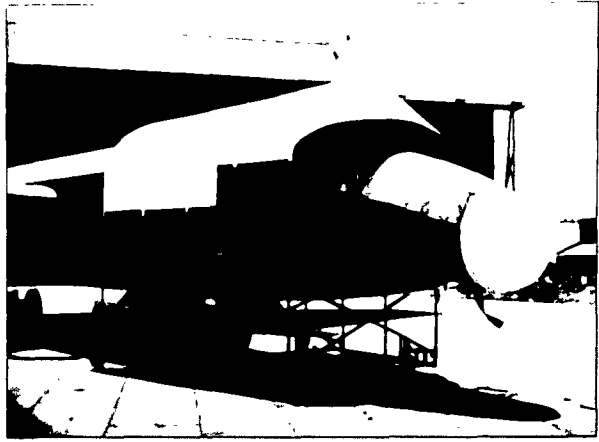

FIG.42.

AVERAGE CABIN TEMPERATURES - TROPICAL SUMMER.



View of protective awning in situ.

FIG.43.

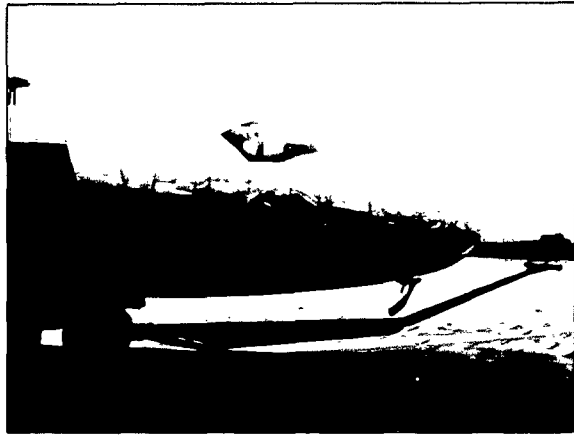

Extent of paper covering during ground trial.

FIG.44.



View of diffuser nozzle - coolair minor

FIG.45.

SK 194-796 PART OF REPORT N8A8A.E/86/L CANBERRA, W.D. 954. TR. K.M. (CH. W.P. WHITE) APP. 2000 for Sef E (2075)

M.L. COOLAIR MINOR.
(SIMILAR ARRANGEMENT
USED FOR GODFREY
R. 2000)

DIFFUSER ADDED TO
STANDARD EQUIPMENT
TO FACILITATE
DISTRIBUTION OF
COOLING AIR.

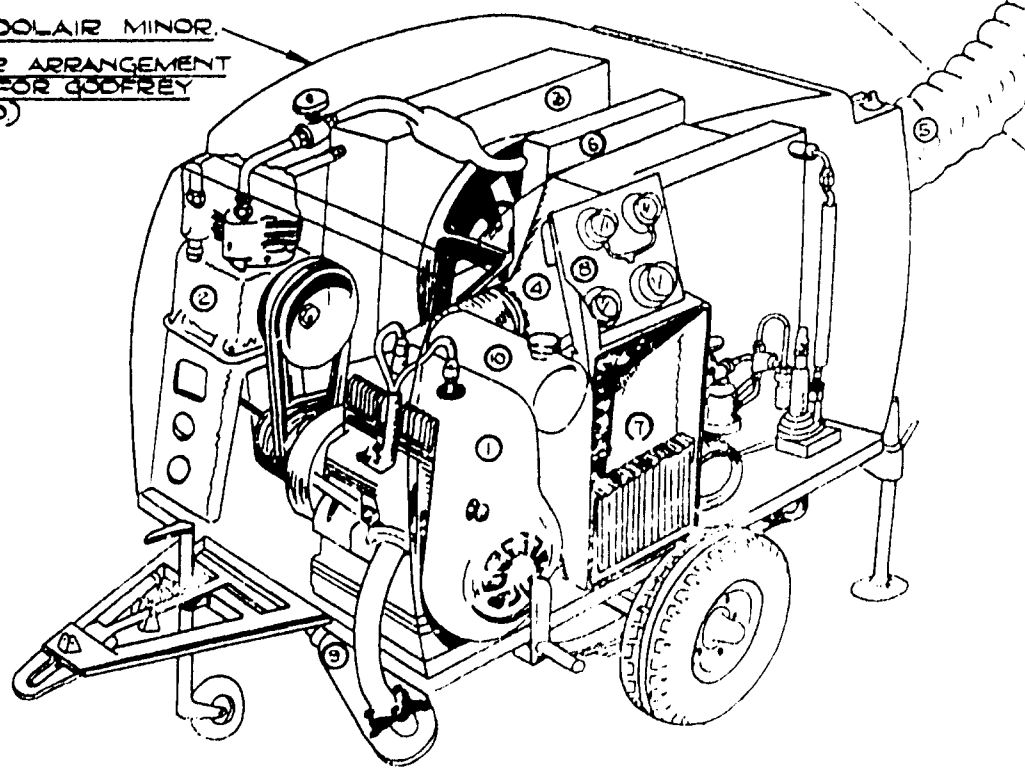

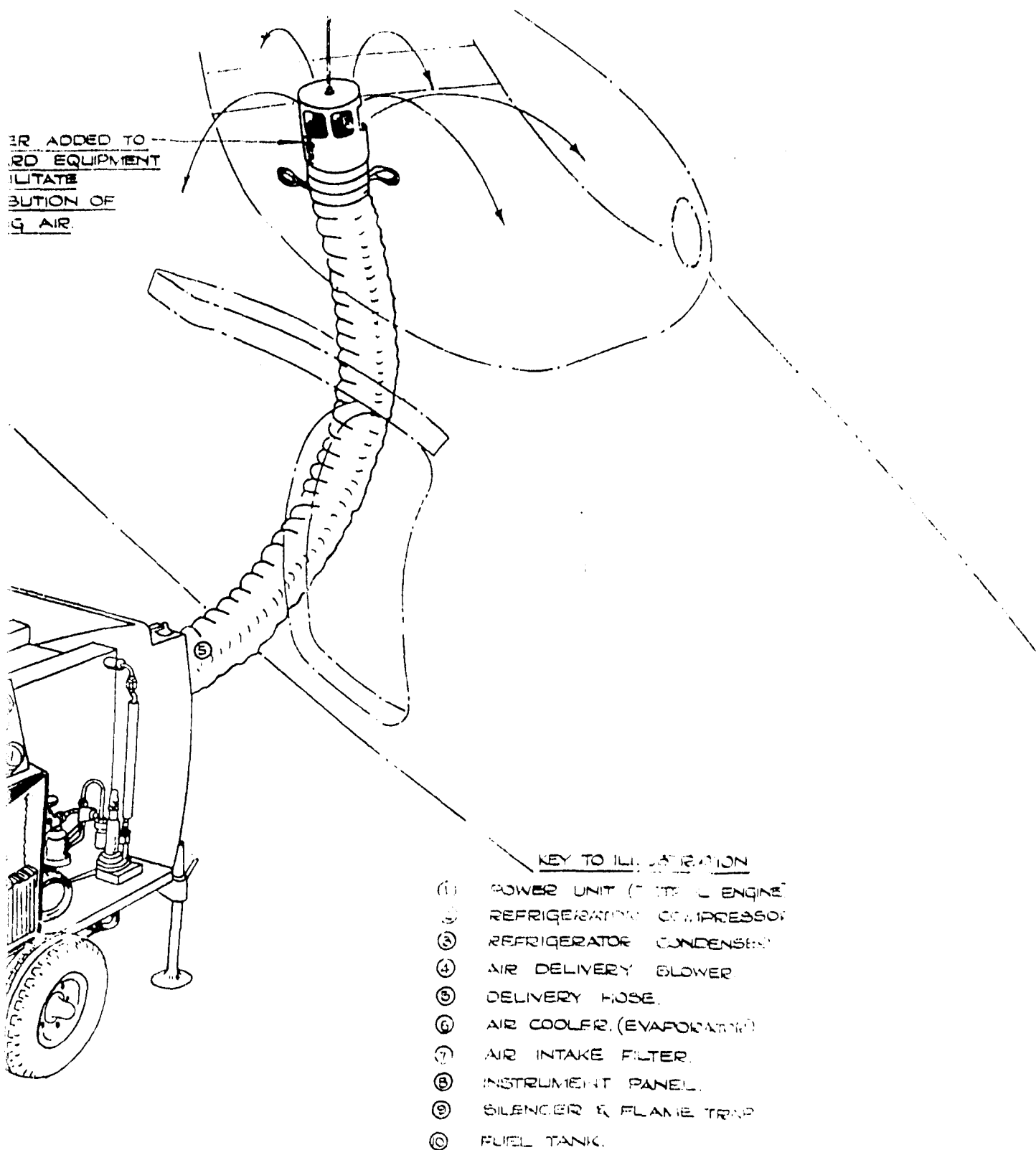

ARRANGEMENT DURING GROUND COOLING TRIALS

FIG.47.

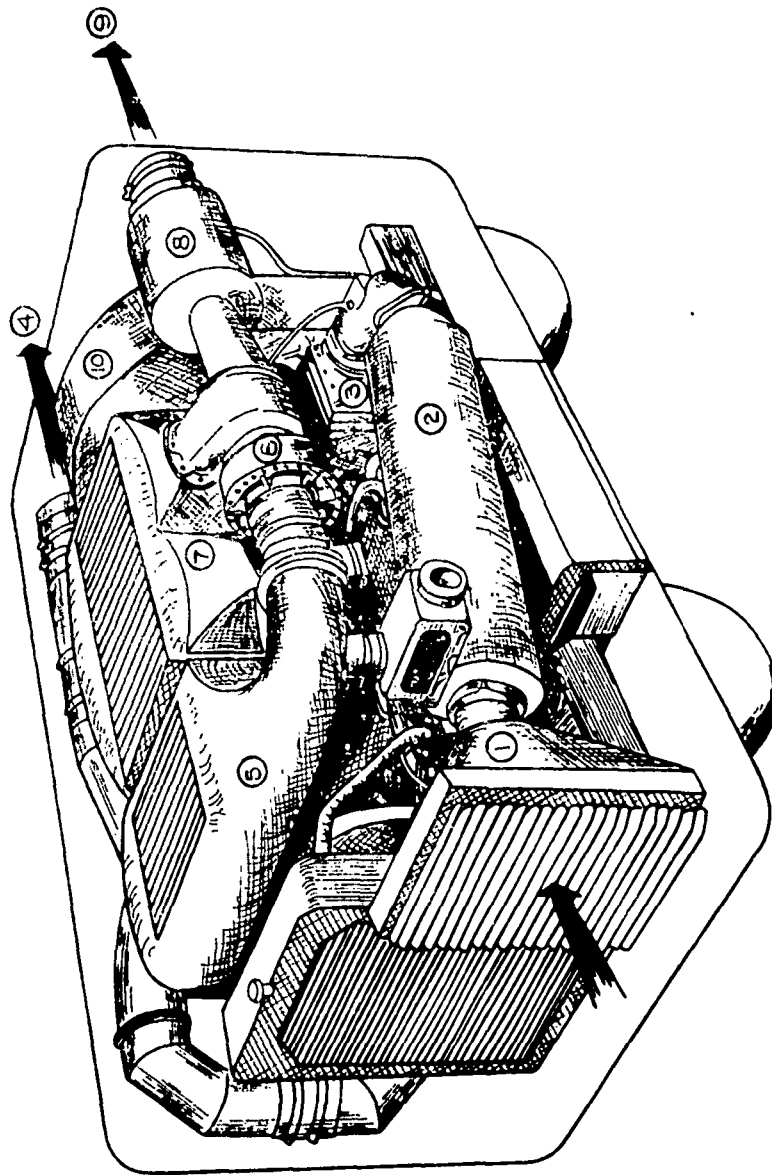

KEY TO ILLUSTRATION.

- ① COMPRESSOR AIR INTAKE & FILTER.
- ② INTAKE SILENCER.
- ③ COMPRESSOR.
- ④ HOT AIR OUTLET.
- ⑤ PRIMARY HEAT EXCHANGER.
- ⑥ COLD AIR LINT.
- ⑦ SECONDARY HEAT EXCHANGER.
- ⑧ WATER SEPARATOR.
- ⑨ COLD AIR OUTLET.
- ⑩ AXIAL COOLING FAN.

Canberra WD. 954

Ground Temperatures & Cooling Effects of Coolair Minor

F.S.J. Khartoum 15.7.52.

Aircraft parked in sun on hardstanding. All doors closed. Heading south into wind. No protection from solar radiation

Time	PILOT		NAVIGATOR		BOB ALMER		Average Cabin Temperature	True O.P.P.	Radio	Gyro Insts.	Heater Insts.	Barometric	% R.H.		COLD AIR MINOR				Remarks	
	Head	Hands	Feet	Hands	Feet	Hands							Feet	In Cabin	Outside	Cond. Press. lbs O"	Evap. Press. lbs O"	Eng. R.P....		Cooling air Temp.
0930	33	28	37	36	35	39	36	35	32	32	35	35	55							These temps taken in hangar 4/c pushed out 0935 hrs. Light wind (7 kts) No cloud No wind Cloud 2/10 at 5000' Coolair Minor started 1501 Cooling ceased 1529 Coolair Minor received Sun obscured intermittently by thin layer cloud 2/10 at 5000' Test completed 1600 hrs
1000	56	45	29	42	36	41	37	36	36	40	48	51	53	55						
1100	67	56	48	51	38	51	45	38	40	51	53	59	40	52						
1200	72	62	55	56	39	57	51	39	42	58	55	65	36	49						
1300	76	63	60	62	41	65	56	41	43	62	58	67	38	47						
1400	78	71	65	64	41	70	62	41	44	64	59	68	39	48						
1500	81	74	65	62	41	60	62	41	44	64	60	70	39	46						
1505	70	70	53	60	41	67	60	41	46	64	60	64	36	46						
1510	62	64	60	55	41	65	57	41	46	60	60	64	34	46						
1515	56	60	56	51	41	62	54	41	46	50	53	59	35	46						
1520	51	56	52	48	41	60	53	41	47	48	55	60	36	47						
1525	47	54	51	47	41	59	51	41	47	48	51	51	35	47						
1530	47	54	50	46	41	58	50	41	47	48	50	50	34	47						
1535	48	55	50	46	41	57	50	41	47	47	50	51	36	47						
1540	50	53	52	48	42	57	50	42	47	48	52	52	35	47						
1545	53	60	53	50	42	57	50	42	47	48	53	53	36	47						
1550	55	62	54	51	42	58	51	42	47	48	54	54	36	47						
1555	57	61	55	52	42	59	52	42	47	48	55	56	37	47						
1600	59	66	56	53	42	60	53	42	47	48	56	57	38	47						

Note - All temperatures are given in degrees centigrade. Black bulb reading at pilots head position 86°C at 1500 hrs.

Canberra ID. 954

Ground Temperatures and Cooling Effects of Coolair Minor

T.E.U. Khartoum 16.7.52

Aircraft parked or handstanding in sun. All doors closed. Heading south into wind. Sun awning and nose bag in use with fibreglass on fwd fus.

Local Time	PILOT		NAVIGATOR		CABIN ALTER		Average Cabin Temperature	Time O.A.S.	Radio	Gyro Insts.	Rear Fus.	Bomb Sight	R.H.		COLD AIR MINOR				Remarks	
	Head	Hands	Feet	Hands	Feet	Hands							Feet	In Cabin	Outside	Cond. Press. lbs □ " lbs □ "	Evap. Press. R.P.H.	Engine Cooling Air Temp.		Cond. Press. lbs □ " lbs □ "
0930	38	37	36	34	33	37	35	33					59	65						These temps taken in hangar i/c pushed out 0935 hrs. Light wind (7 knots) No cloud No wind Cloud 2/10 at 5000' Coolair minor started 1501 ON Coolair minor removed Cooling ceased 1529 Coolair minor removed ON Coolair minor removed Test completed 1600 hrs.
1000	38	38	38	36	35	38	36	35					59	51						
1100	40	40	40	40	37	40	38	37					59	45						
1200	44	44	45	43	41	44	43	40					55	44						
1300	44	44	44	44	42	44	44	40					53	43						
1400	45	42	46	44	43	46	45	41					50	44						
1500	46	43	47	45	44	47	46	41					50	43						
1505	44	46	47	45	44	43	46	41					43	41						
1510	40	45	46	44	43	43	45	41					43	41						
1515	37	43	42	42	42	36	44	41					47	42						
1520	36	42	42	40	40	36	43	40					45	42						
1525	35	41	41	39	39	36	42	39					45	42						
1530	35	41	41	38	37	36	42	40					45	42						
1535	38	42	42	41	40	38	43	41					45	41						
1540	39	42	43	42	41	40	44	41					46	41						
1545	40	44	44	43	42	42	44	41					47	41						
1550	41	44	44	44	43	43	44	40					43	40						
1555	42	44	44	44	43	44	44	41					43	41						
1600	43	44	44	44	43	45	44	41					43	41						

Note - All temperatures are given in degrees centigrade. Black bulb reading at pilots head position 48°C at 1500 hrs.

Carberra ID.954

Cabin Temperatures recorded on Ground

T.E.U. Khartoum 17.7.52

Aircraft parked in sun on hardstanding. All doors closed. Heading south into wind. fwd fuselage covered with white paper

Time	PILOT		NAVIGATOR		BOMB ALIER		Average Cabin Temperature	True O.S.	Radio	Gyro Insts.	Rear Fus.	Fwd Sight	R.H.		Remarks
	Head	Feet	Head	Feet	Head	Feet							In Cabin	Outside	
0930	38	37	36	35	38	35	36	35					64	60	These temps taken in hangar - i/c pushed out 0935 hrs.
1000	45	41	39	38	41	38	40	36					57	52	No cloud - wind 10 knots.
1100	44	44	42	41	43	41	43	38					51	49	No cloud - wind 10 knots.
1200	53	51	47	46	48	46	48	40					49	47	No cloud - wind 7 knots.
1300	58	56	51	50	52	50	52	41					46	47	Light wind - 2/10 cloud at 5000'.
1400	61	61	55	53	55	54	55	41					44	46	No wind - 2/10 cloud at 5000'.
1500	62	60	56	54	56	54	56	41					44	45	No wind - 2/10 cloud at 5000'.

Note - All temperatures in degrees centigrade.
Black bulb reading at pilots head position 62°C at 1500 hrs.

FIG. 51.

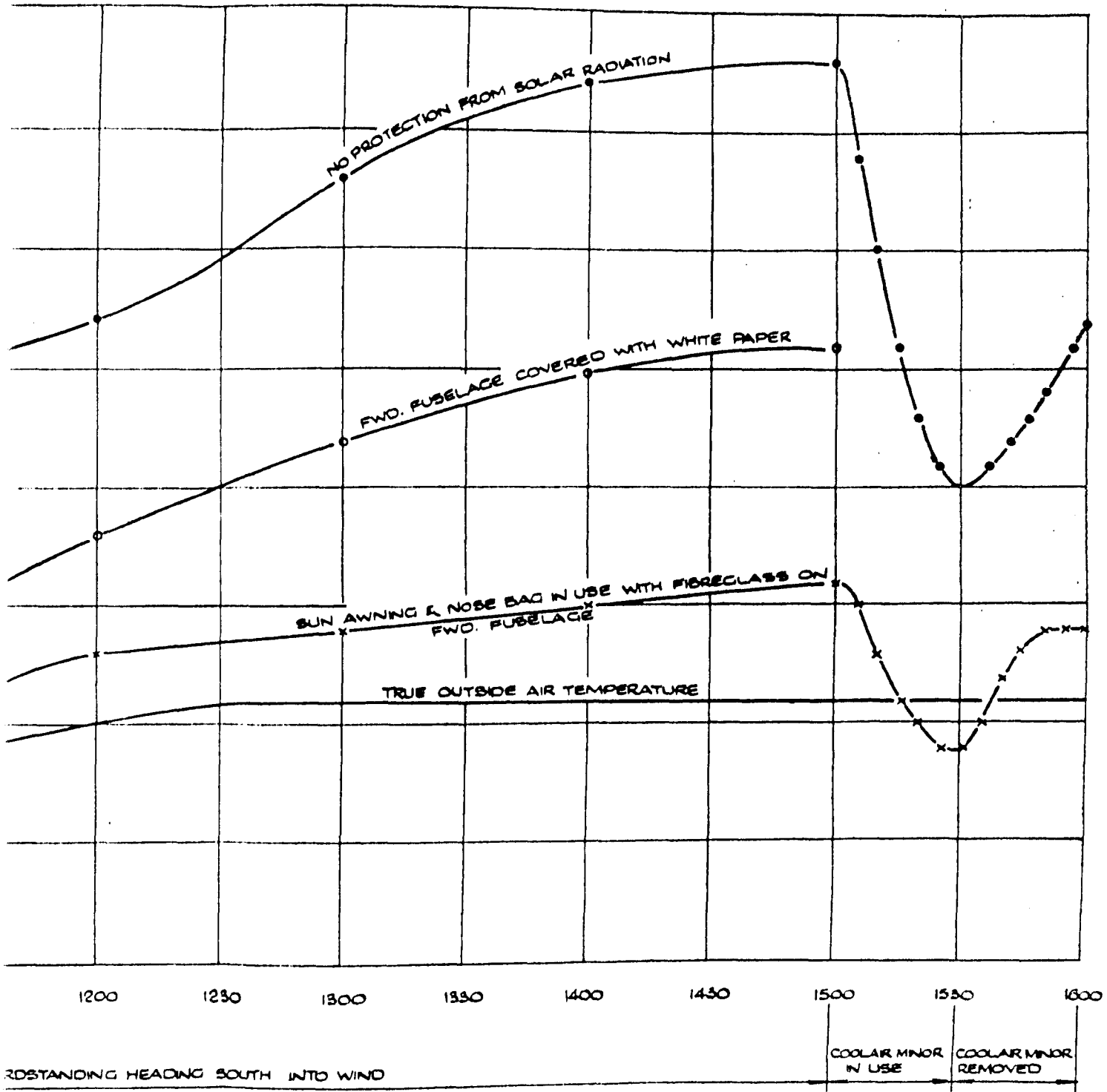

GROUND TEMPERATURE-TRIALS AVERAGE CABIN TEMPERATURES.

Canberra WD.954

T.E.U. Khartoum 20.7.52

Engine Bay Temperatures Recorded during Ground Running

Aircraft had been parked in sun on handstanding for two hours prior to commencement of engine run & the following temperatures were recorded after 10 minutes ground running for B.P.G.U. and acceleration checks

Local Time	Port Engine R.P.M.	THERMOCOUPLE					Average Engine Bay Temperature	True O.A.T.
		1	2	3	4	5		
1255	2000	85	82	112	70	78	85	40
1256	4500	85	80	110	70	78	85	40
1257	5500	90	80	110	72	78	85	40
1257 $\frac{1}{2}$	6600	105	85	110	72	78	91	40
1258	6900	120	90	115	75	78	96	40
1259	7000	130	95	118	75	75	99	40
1259 $\frac{1}{2}$	7200	150	100	120	75	75	105	40
1300	7400	155	100	122	75	78	106	40
1300-	7600	180	105	130	75	78	113	40
1300 $\frac{1}{2}$	7800	195	110	140	75	78	120	40
1300 $\frac{3}{4}$	7400	210	120	150	75	75	126	40
1301	7200	212	125	155	75	75	128	40
1302	7000	210	130	160	75	75	130	40
1302 $\frac{1}{2}$	6600	205	130	160	75	75	129	40
1303	5500	190	125	160	75	78	126	40
1303 $\frac{1}{2}$	4500	170	122	160	80	80	123	40
1305	2750	140	118	150	80	80	114	40

Positions of Thermocouples	
1	Engine compressor casing.
2	Torch igniter cap.
3	Booster coil case.
4	Top rear side main spar near jet pipe.
5	Inside nacelle skin on G - 5" aft of main spar

Note - All temperatures are in degrees centigrade.

Canberra WD.954

Engine Bay Temperatures Recorded on Ground

T.E.U. Khartoum 15.7.52

Aircraft parked in sun on hardstanding. Heading south into wind. Engines not running

Local Time	THERMOCOUPLES					Average Engine Bay Temperature	True O.A.T.	Remarks
	1	2	3	4	5			
0930	40	40	40	40	40	40	35	These temps taken inside hangar - 4/c pushed out 0935 hrs.
1000	41	41	42	45	60	46	36	No cloud - wind 7 knots.
1100	44	49	50	59	68	54	38	No cloud - wind 7 knots.
1200	48	52	55	62	72	58	39	No cloud - wind 7 knots.
1300	52	59	59	68	76	63	41	2/10 cloud 5000' - No wind.
1400	53	59	60	68	78	64	41	2/10 cloud 5000' - No wind.
1500	54	59	61	68	79	64	41	2/10 cloud 5000' - No wind.

Positions of Thermocouples	
1	Engine compressor casing.
2	Torch igniter cap.
3	Booster coil case.
4	Top rear side main spar near jet pipe.
5	3 - 5" aft of main spar.

Note - All temperatures in degrees centigrade.

SK. N9A. 4799. 22ND PART OF REPORT N9A&A.E.E. 861/11 CANBERRA WD954 TR 5 M. CH W.P. WHITE. APP. *Belcher* for Sofe 20.7.53.

FIG. 54.

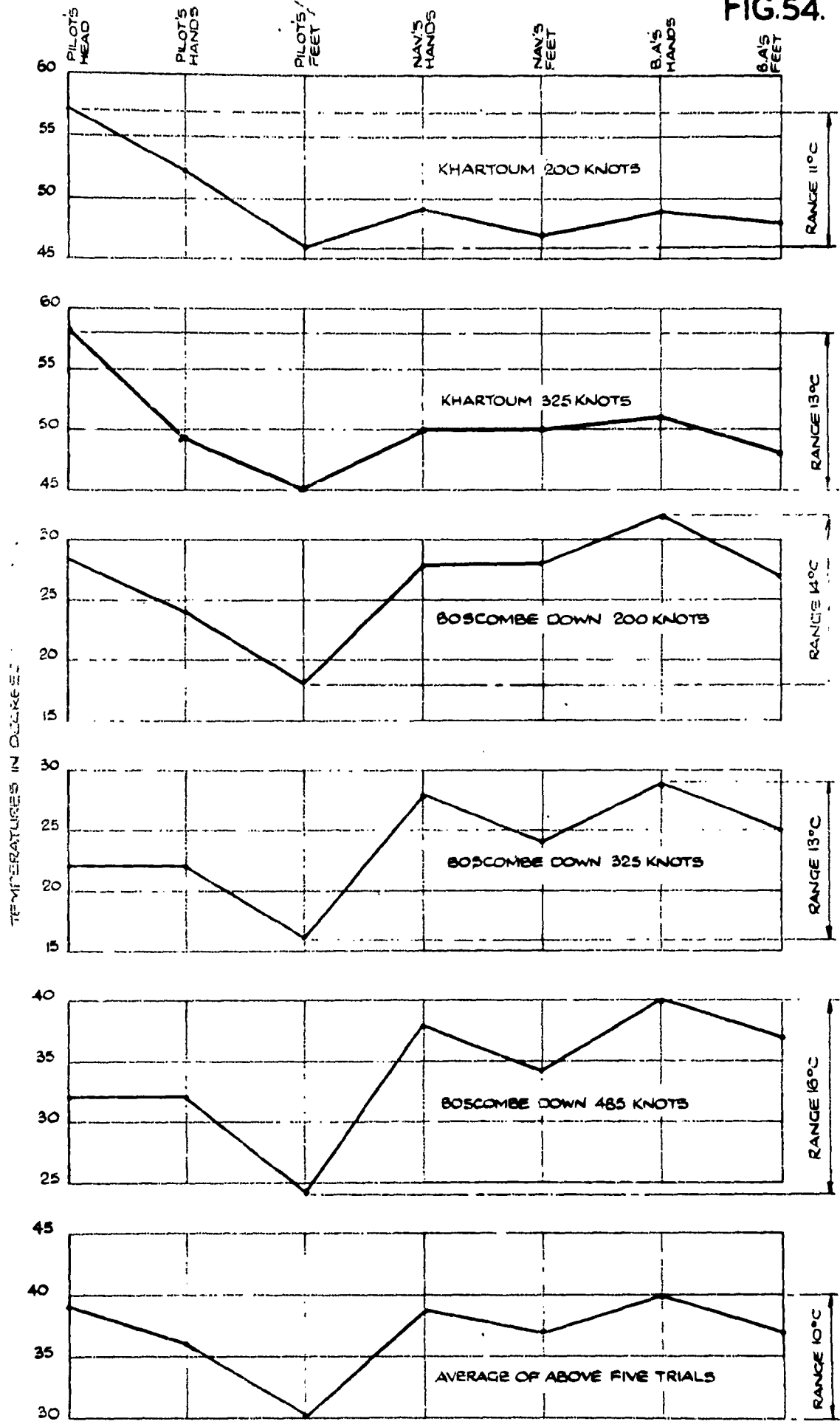

STABILISED TEMPERATURES SHOWING DISTRIBUTION OF COOLING

FIG.55

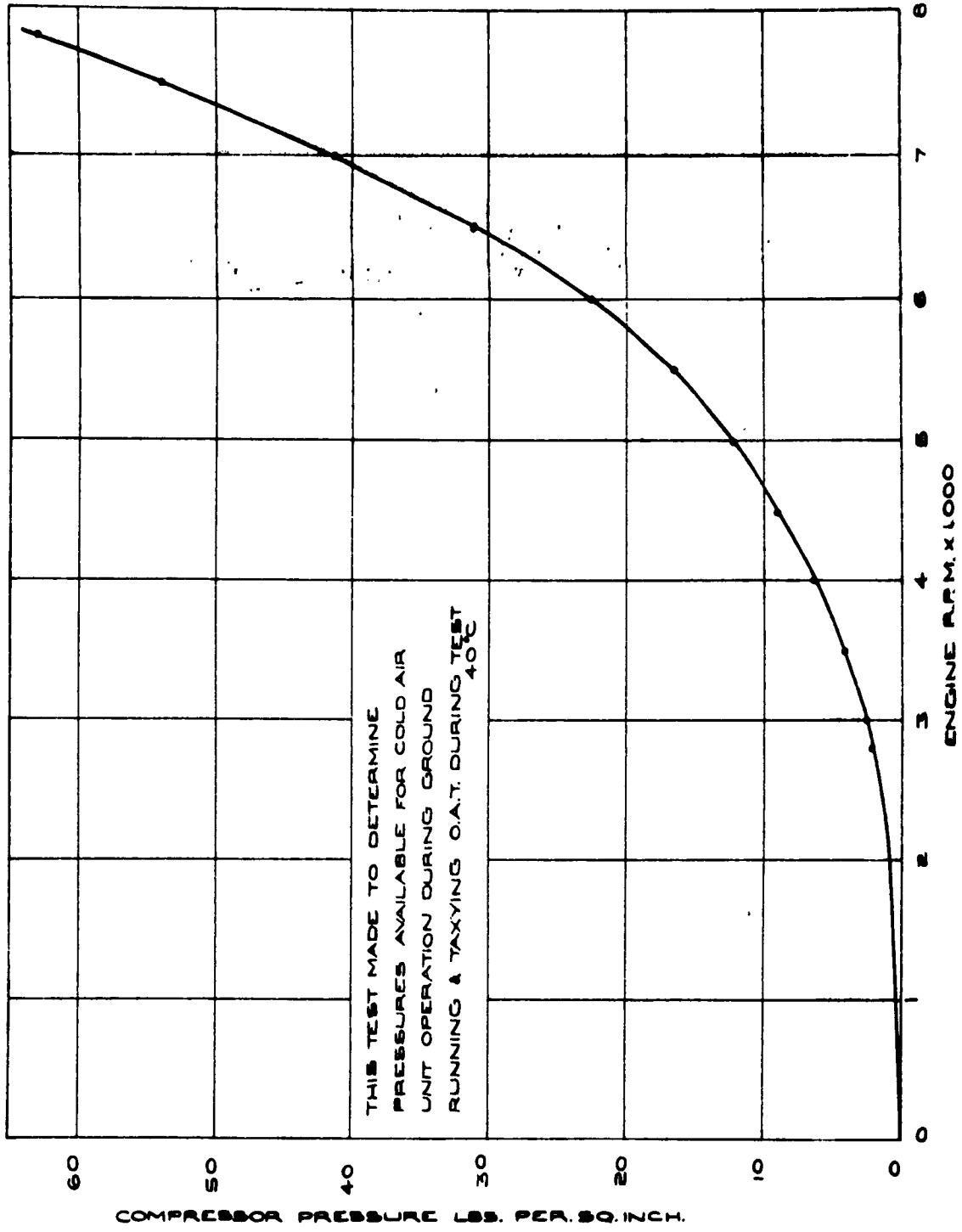

R.P.M.	PRESS
2800	2
3000	2½
3500	4
4000	6
4500	9
5000	12
5500	16½
6000	22½
6500	31
7000	41
7500	54
7800	63

ENGINE COMPRESSOR PRESSURES DURING GROUND RUNNING

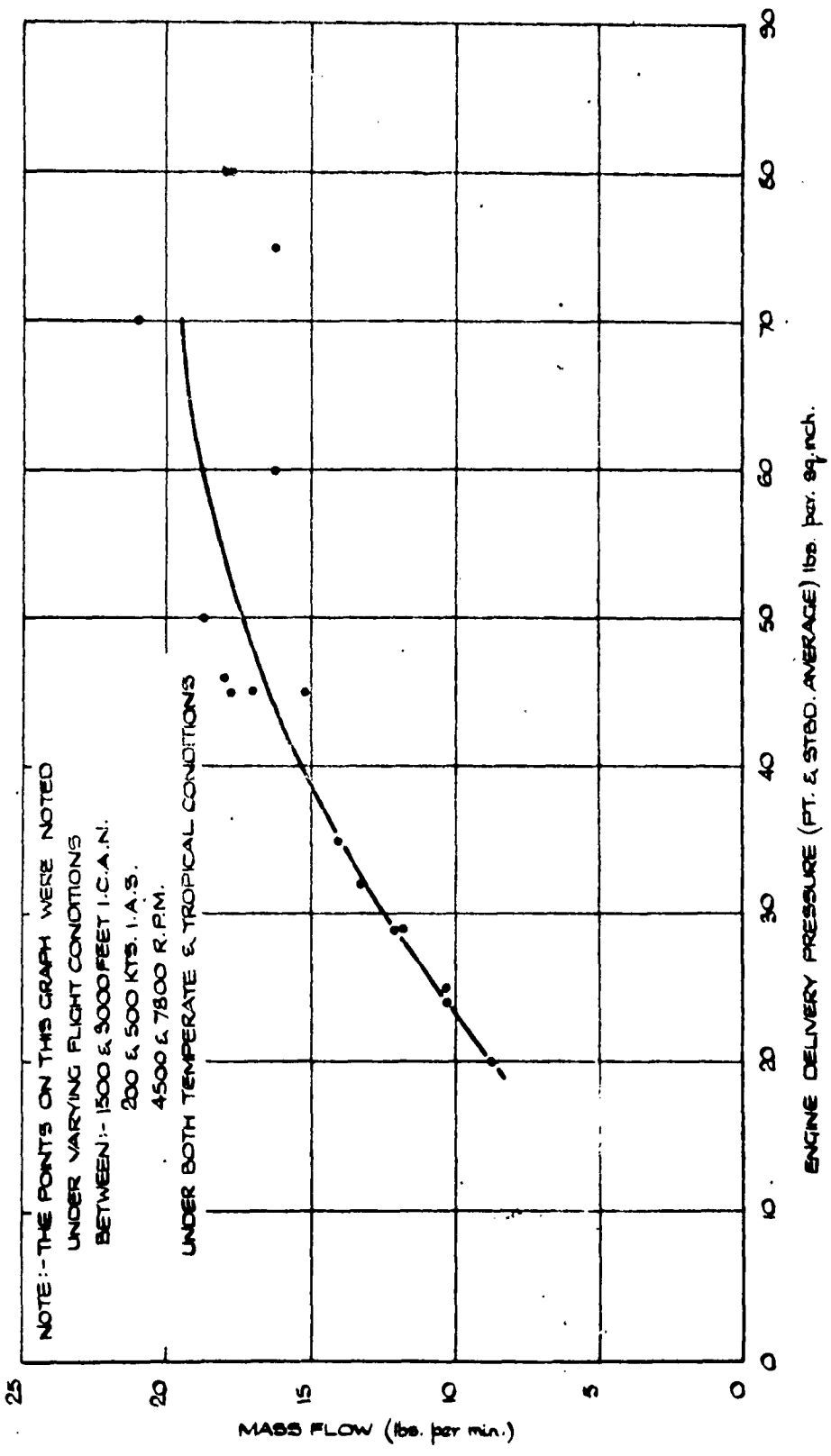
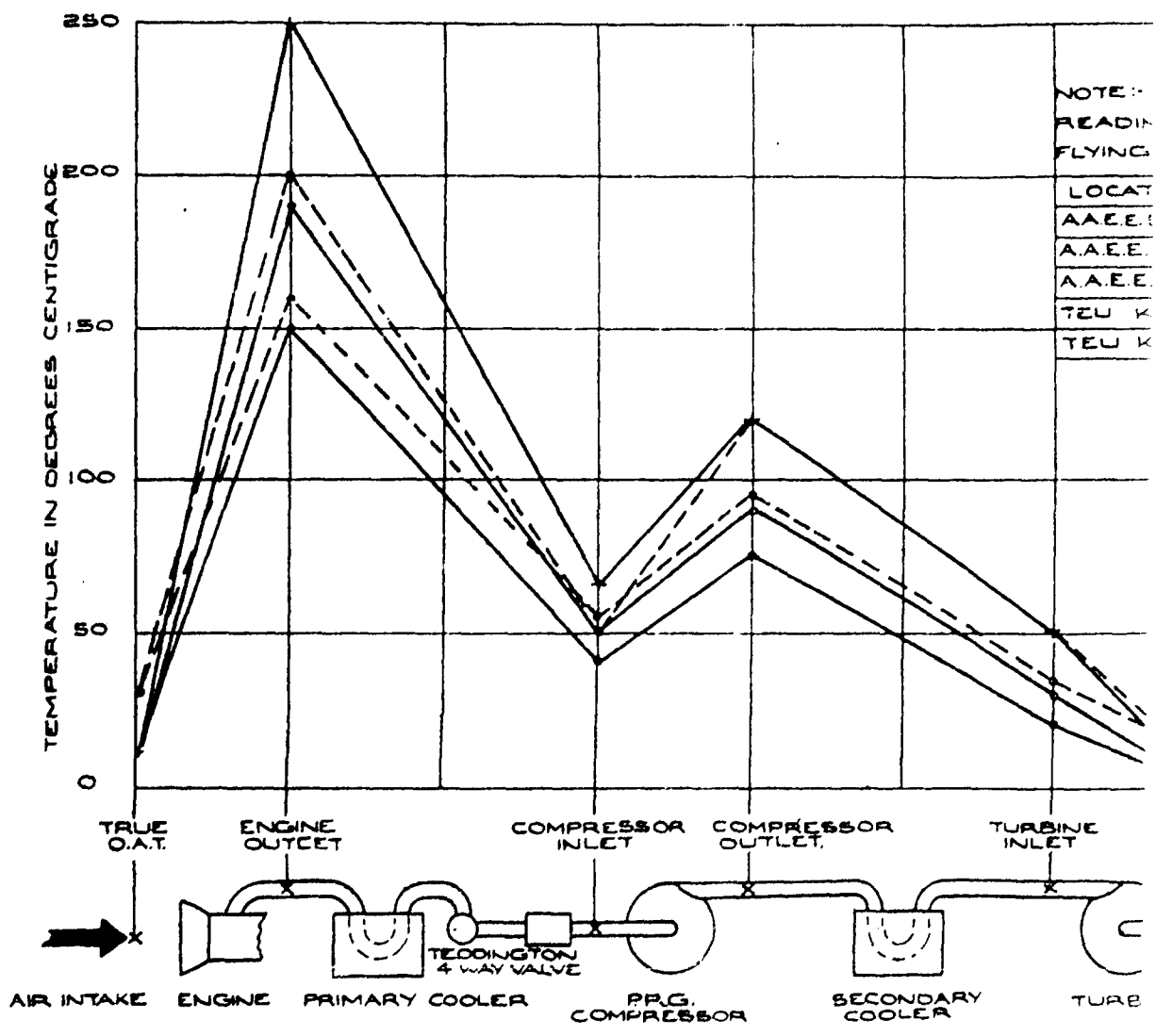

FIG. 56.

VARIATIONS IN MASS FLOW WITH ENGINE DELIVERY PRESSURE.



NOTE:
 READING
 FLYING
 LOCAT
 A.A.E.E.
 A.A.E.E.
 A.A.E.E.
 TEU K
 TEU K

TEMP

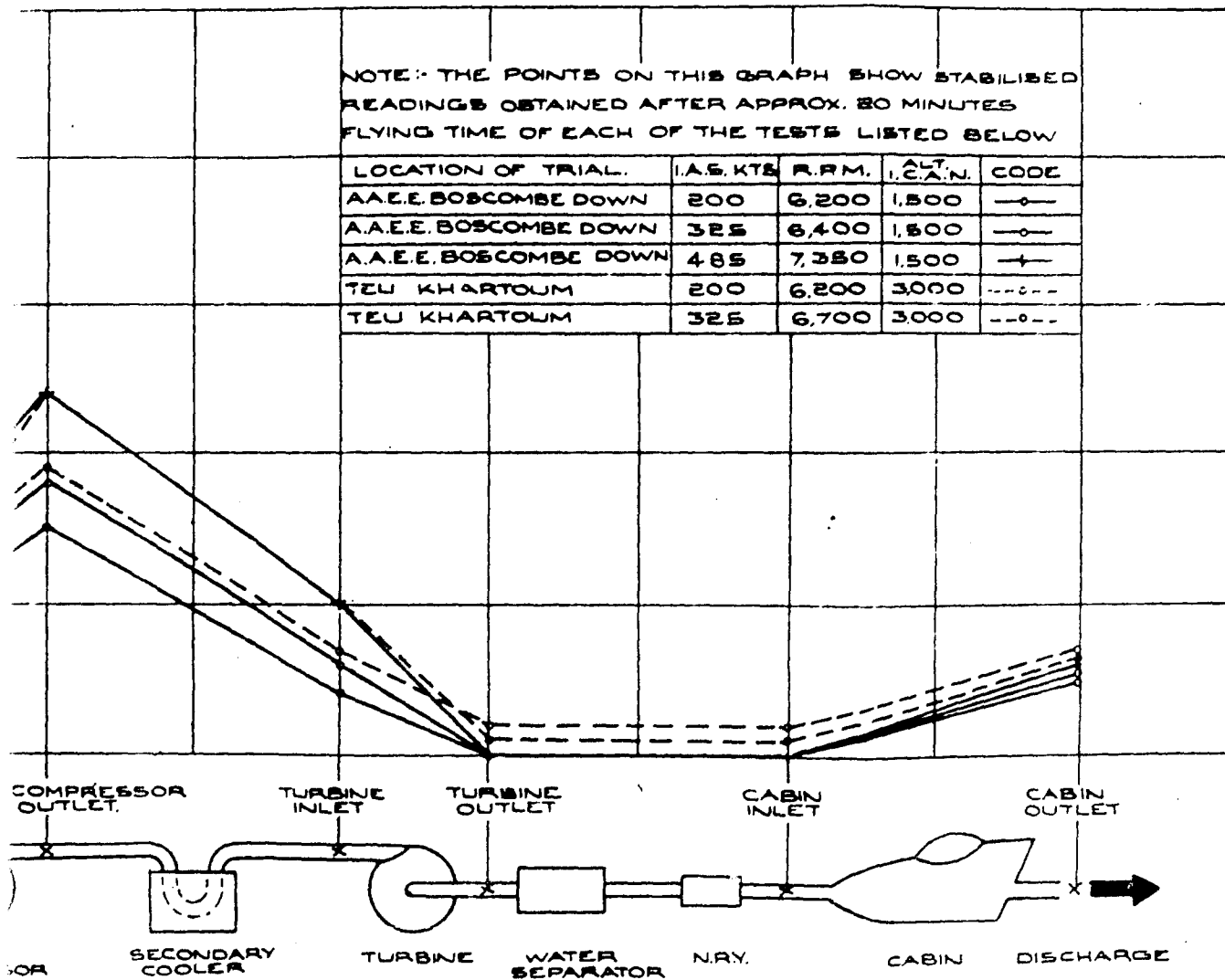

TEMPERATURE VARIATIONS IN COLD AIR SYSTEM.

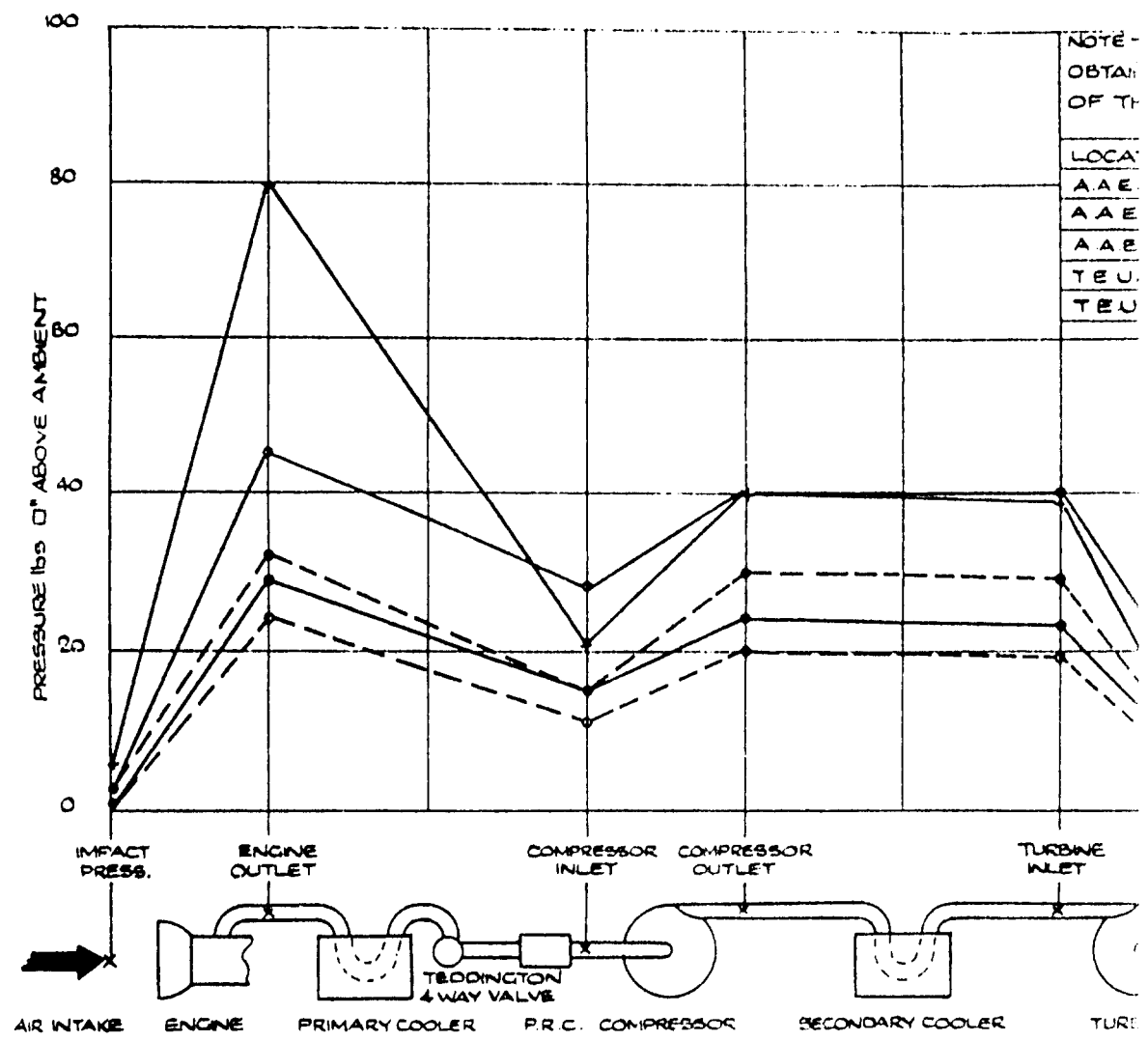

NOTE - THE POINTS ON THIS GRAPH SHOW STABILISED READINGS OBTAINED AFTER APPROX. 20 MINUTES FLYING TIME OF EACH OF THE TESTS LISTED BELOW.

LOCATION OF TRIAL	I.A. SKTS.	R.P.M.	ALT. (FEET)	CODE
A.A.E.E. BOSCOMBE DOWN	200	6200	1500	—●—
A.A.E.E. BOSCOMBE DOWN	325	6400	1500	—○—
A.A.E.E. BOSCOMBE DOWN	485	7350	1500	—+—
T.E.U. KHARTOUM	200	6200	2000	—○—
T.E.U. KHARTOUM	325	6700	2000	—●—

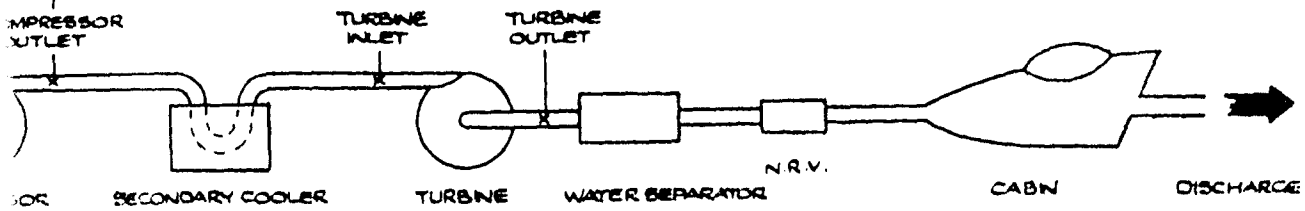
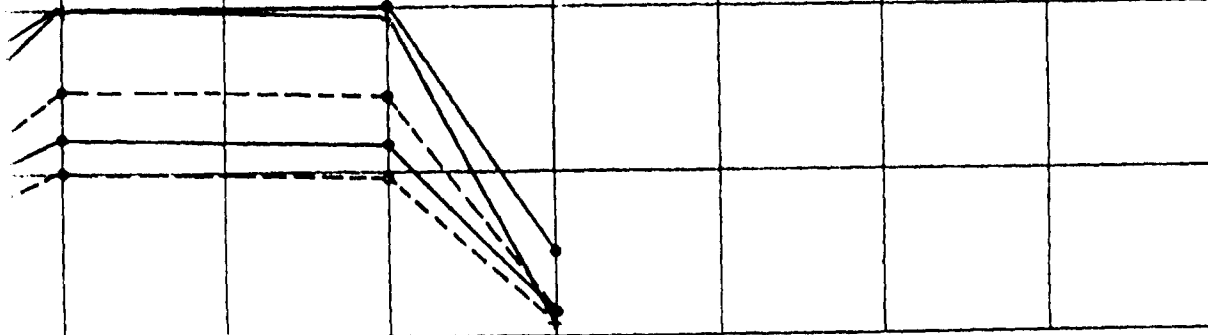

PRESSURE VARIATIONS IN COLD AIR SYSTEM.

NOTE:- THE POINTS ON THIS GRAPH WERE NOTED UNDER VARYING FLIGHT CONDITIONS BETWEEN :- 1500 & 3000 FT. I.C.A.N.
 200 & 500 KTS I.A.S.
 4500 & 7800 R.P.M.
 UNDER BOTH TEMPERATE & TROPICAL CONDITIONS.

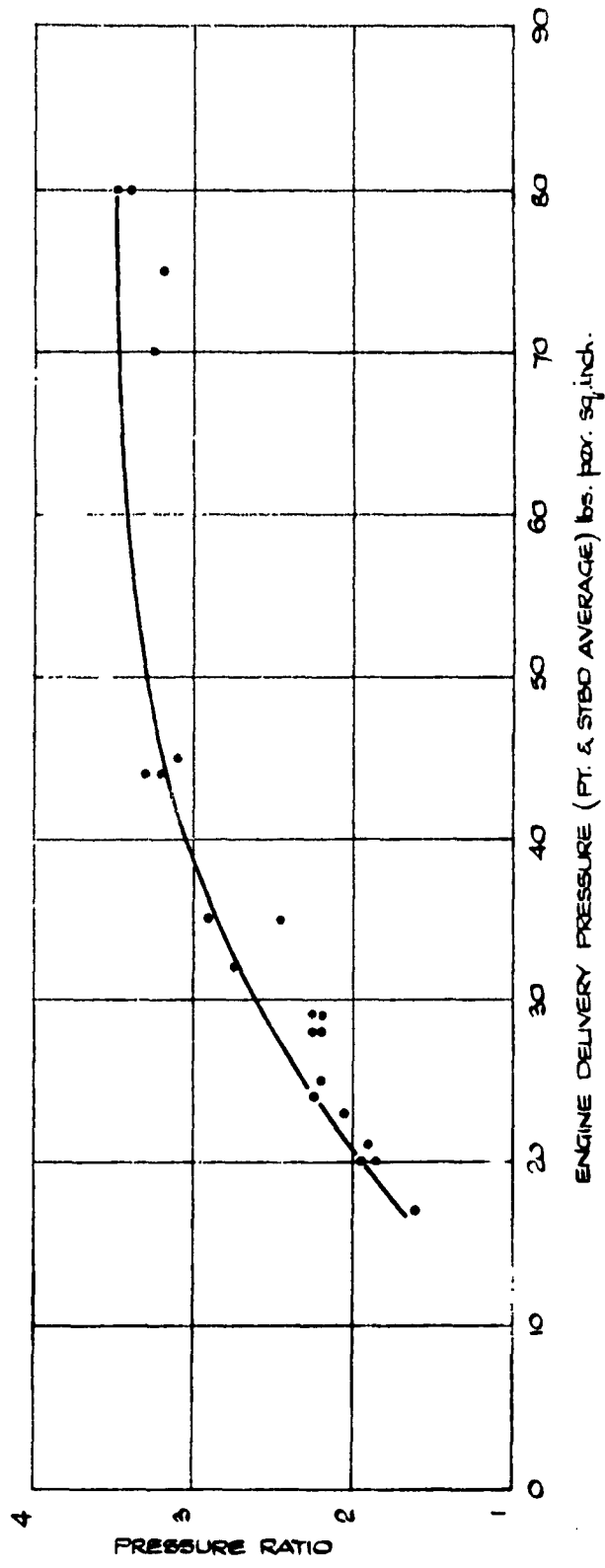

VARIATION IN PRESSURE RATIO WITH ENGINE DELIVERY PRESSURE.

FIG.60.

SK. NO. 4805 22ND PART OF REPORT N9A&EE/ 601/1 CANBERRA WD 954 TR. SM. CH. W.P. WHITE APP. *blue* for Sof E 20.7.53

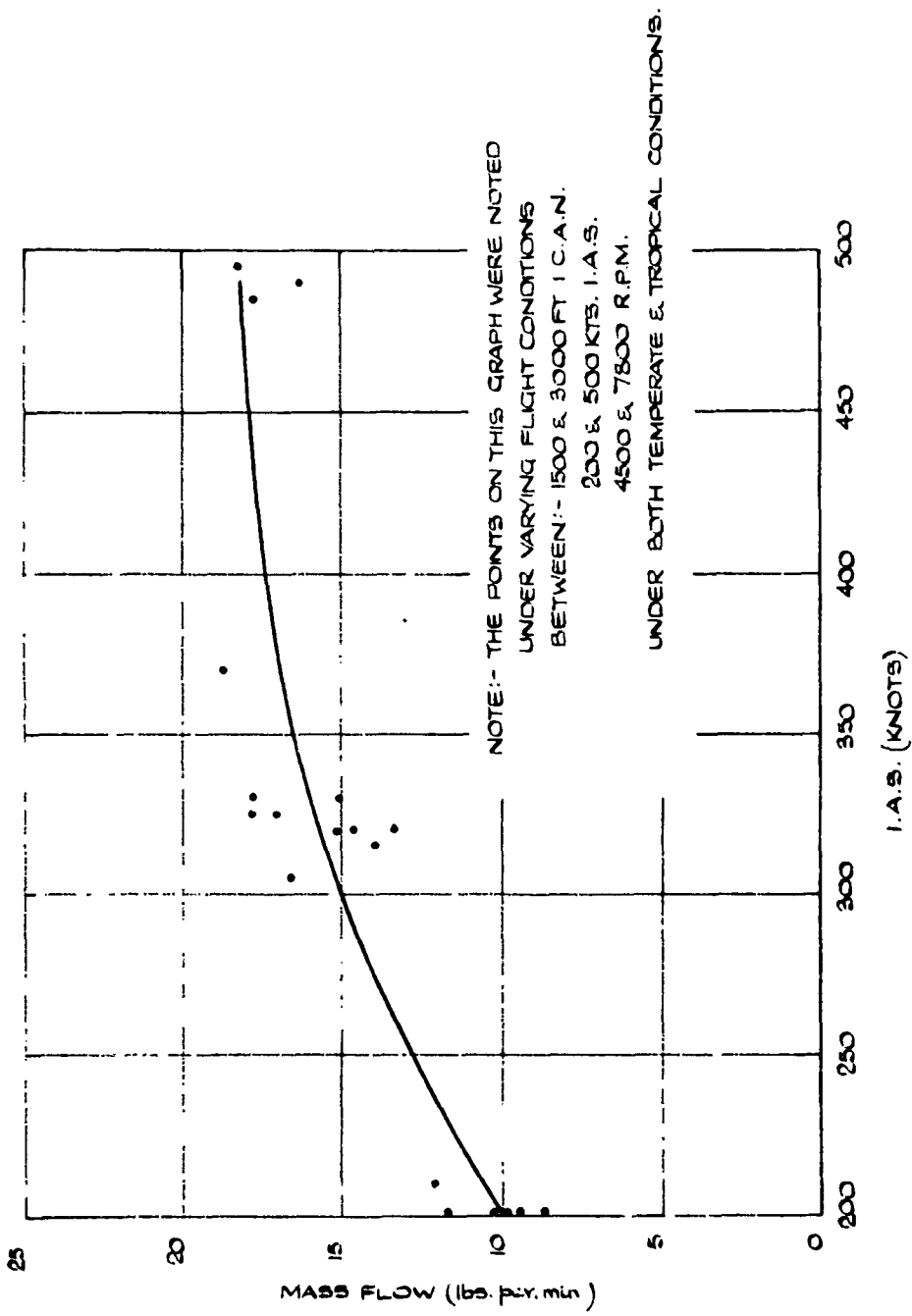

VARIATION IN MASS FLOW WITH INDICATED AIRSPEED.

Armed Services Technical Information Agency

AD

20267

NOTICE: WHEN GOVERNMENT OR OTHER DRAWINGS, SPECIFICATIONS OR OTHER DATA ARE USED FOR ANY PURPOSE OTHER THAN IN CONNECTION WITH A DEFINITELY RELATED GOVERNMENT PROCUREMENT OPERATION, THE U. S. GOVERNMENT THEREBY INCURS NO RESPONSIBILITY, NOR ANY OBLIGATION WHATSOEVER; AND THE FACT THAT THE GOVERNMENT MAY HAVE FORMULATED, FURNISHED, OR IN ANY WAY SUPPLIED THE SAID DRAWINGS, SPECIFICATIONS, OR OTHER DATA IS NOT TO BE REGARDED BY IMPLICATION OR OTHERWISE AS IN ANY MANNER LICENSING THE HOLDER OR ANY OTHER PERSON OR CORPORATION, OR CONVEYING ANY RIGHTS OR PERMISSION TO MANUFACTURE, USE OR SELL ANY PATENTED INVENTION THAT MAY IN ANY WAY BE RELATED THERETO.

Reproduced by
DOCUMENT SERVICE CENTER
KNOTT BUILDING DAYTON, OHIO

RESTRICTED



*Information Centre
Knowledge Services*
[dstl] *Porton Down,
Salisbury
Wiltshire
SP4 0JQ
22060-6218
Tel. 01980-613733
Fax 01980-613970*

Defense Technical Information Center (DTIC)
8725 John J. Kingman Road, Suit 0944
Fort Belvoir, VA 22060-6218
U.S.A.

AD#: AD020267

Date of Search: 29 July 2008

Record Summary: AVIA 18/4580

Title: Canberra Mk 2 WD 954 (2 x Avon Mk 1): cabin temperature and cold unit trials at
Aeroplane and Armament Experimental Establishment (A&AEE) at Khartoum and Aden
Availability Open Document, Open Description, Normal Closure before FOI Act: 30 years
Former reference (Department) Report AAEE/861/1 Pt 22
Held by The National Archives, Kew

This document is now available at the National Archives, Kew, Surrey, United Kingdom.

DTIC has checked the National Archives Catalogue website (<http://www.nationalarchives.gov.uk>) and found the document is available and releasable to the public.

Access to UK public records is governed by statute, namely the Public Records Act, 1958, and the Public Records Act, 1967.

The document has been released under the 30 year rule.

(The vast majority of records selected for permanent preservation are made available to the public when they are 30 years old. This is commonly referred to as the 30 year rule and was established by the Public Records Act of 1967).

This document may be treated as UNLIMITED.