

UNCLASSIFIED

AD NUMBER

AD020419

CLASSIFICATION CHANGES

TO: unclassified

FROM: secret

LIMITATION CHANGES

TO:

Approved for public release, distribution unlimited

FROM:

Distribution authorized to U.S. Gov't. agencies and their contractors; Administrative/Operational Use; 25 SEP 1953. Other requests shall be referred to Air Force Cambridge Research Laboratory, Hanscom AFB, MA.

AUTHORITY

USAF, MIT NOTICE 7 FEB 1963; usaf, MIT/LL LTR, 11 FEB 1981

THIS PAGE IS UNCLASSIFIED

Reproduced by

Armed Services Technical Information Agency

DOCUMENT SERVICE CENTER

KNOTT BUILDING, DAYTON, 2, OHIO

AD -

20419

SECRET

The following **ESPIONAGE NOTICE** can be disregarded unless this document is plainly marked **RESTRICTED**, **CONFIDENTIAL**, or **SECRET**.

NOTICE: THIS DOCUMENT CONTAINS INFORMATION AFFECTING THE NATIONAL DEFENSE OF THE UNITED STATES WITHIN THE MEANING OF THE ESPIONAGE LAWS, TITLE 18, U.S.C., SECTIONS 793 and 794. THE TRANSMISSION OR THE REVELATION OF ITS CONTENTS IN ANY MANNER TO AN UNAUTHORIZED PERSON IS PROHIBITED BY LAW.

SECURITY INFORMATION

SECRET

AD 020419

MASSACHUSETTS INSTITUTE OF TECHNOLOGY
LINCOLN LABORATORY

JAMMING TESTS ON NOMAC SYSTEMS

B. M. EISENSTADT
P. L. FLECK, JR.
O. G. SELFRIDGE
C. A. WAGNER

25 SEPTEMBER 1953

TECHNICAL REPORT NO. 41

SECRET

SECURITY INFORMATION

SECRET

This document consists of 26
pages. No.
of 450 copies. 267

MASSACHUSETTS INSTITUTE OF TECHNOLOGY
LINCOLN LABORATORY

JAMMING TESTS ON NOMAC SYSTEMS

B. M. Eisenstadt
P. L. Fleck, Jr.
O. G. Selfridge
C. A. Wagner

Technical Report No. 41

25 September 1953

This document contains information affecting the national defense of the United States within the meaning of the Espionage Laws, Title 18, U.S.C. Sections 793 and 794. The transmission or the revelation of its contents in any manner to an unauthorized person is prohibited by law.

CAMBRIDGE

MASSACHUSETTS

SECRET

SECRET

JAMMING TESTS ON NOMAC SYSTEMS

I. INTRODUCTION

A. Purpose

For some time NOMAC (NOise Modulation And Correlation detection) systems have been under study in Group 34 of the Lincoln Laboratory. For military communications, these systems promise to provide security, reliability, and greatly reduced vulnerability to jamming. Several experimental NOMAC systems have worked satisfactorily in laboratory and field tests, but no adequate study of their vulnerability to jamming has ever been made. The purpose of this report is to describe an experimental study made in the laboratory that shows realistically the actual and relative effectiveness of various types of jamming signals on several different NOMAC systems.

B. NOMAC Systems

NOMAC systems are communication systems that make deliberate use of noise-like signals and correlation detection. Theoretically, these systems should have very high jamming combatting abilities. This expectation has been borne out in the rather limited tests made up to now.

The transmitted signal is constructed with a certain relationship to a reference signal; that relationship incorporates the information to be sent. An identical reference signal is constructed at the receiver in some way, and the information is recovered by correlating the received signal with the reference signal, e. g., by means of a multiplier followed by an integrator whose output is the desired signal.

There are two main ways of implementing a NOMAC system, differing in the way each handles the reference signal. In one system, the reference signal is also transmitted, over another channel, so that this is called a transmitted-reference NOMAC system. In the other, called a stored-reference NOMAC system, the reference signal is stored or constructed at both the transmitter and receiver. The transmitted-reference system puts fewer demands on equipment because it does not need to store a reference signal, but the stored-reference system has greater noise-combatting powers and certain other advantages.

C. Previous Experimental Work

Prior to this study, a few experimental systems had been tested with noise jamming. Basore^{1*} has tested a system in which an "on-off" signal was transmitted. His receiver used threshold detection with just the "on" signal. With Gaussian noise as the jamming signal, the relative number of times that the receiver output signal fell below a predetermined level was measured as a function of signal-to-jamming ratio at the receiver input.

Several NOMAC teletype systems^{2, 3} have been tested in which the frequency of error of printed teletype characters was measured as a function of signal-to-jamming ratio, using Gaussian noise for the interference. Although these measurements gave a clear evaluation of over-all system performance, they did not indicate the frequency of error of the binary symbols

*Refer to numbered references at end of report.

SECRET

obtained from the NOMAC detector. Because of effects such as the loss of synchronization, the teletypewriter frequently printed errors when the binary signal from the NOMAC receiver was free of errors.

II. THE BASIC EXPERIMENTAL SYSTEMS

The principles of our NOMAC systems are noise modulation and correlation detection. Our systems use binary symbols, that is, the transmitted signal is one of two noise-like signals, which are also available at the receiver. After the signal has traveled through the channel (and has been corrupted by certain additive interference), it is detected at the receiver by correlating it with the two possible signals. The receiver, of course, picks that signal that has the greater correlation.

In stored-reference systems, the possible (reference) signals are stored or constructed at both transmitter and receiver. In transmitted-reference systems, they are sent over an adjacent frequency band and are thus subject to jamming.

The laboratory model we use is shown in Fig. 1. The two possible signals are iden-

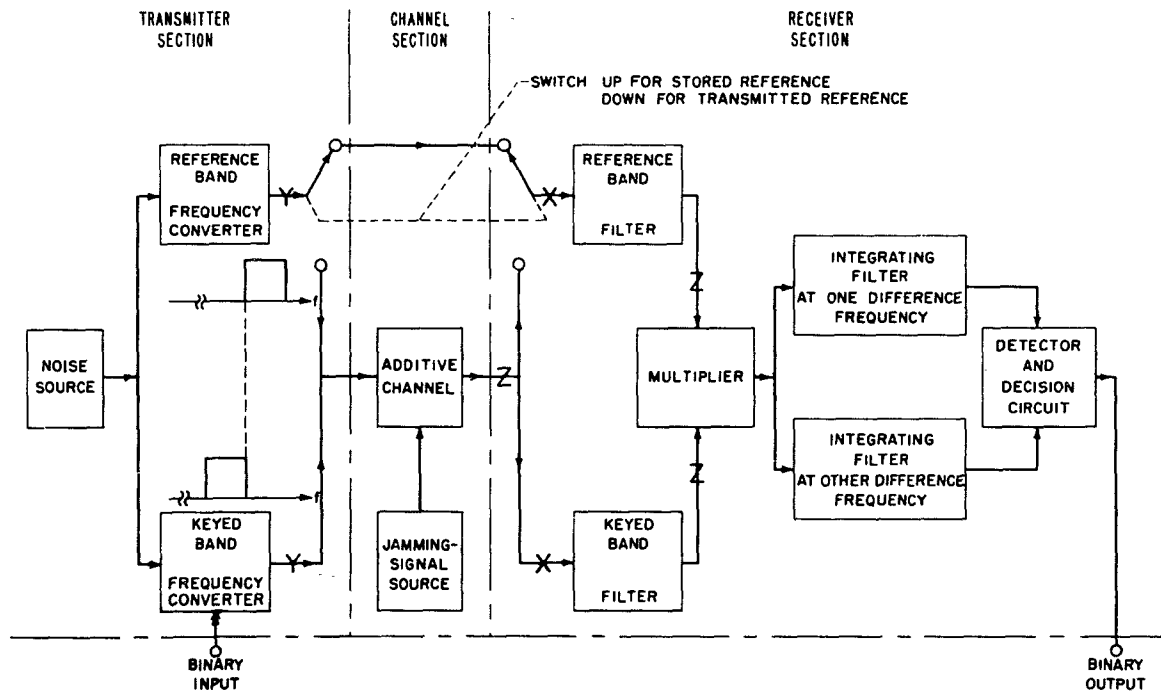

Fig. 1. The basic NOMAC system.

tical noise bands shifted slightly in frequency from each other. This use of two signals differing only in their spectral location requires only one reference signal at the receiver. For stored-reference operation, a copy of the noise is sent undisturbed; for transmitted-reference operation, the reference signal is also sent through the additive channel. The transmitter contains a single noise source which generates a square band of Gaussian noise. This noise band is translated up by one frequency to become the reference band and by another to become the adjacent

keyed band. The spectral position of the keyed band is shifted slightly in accordance with the binary input and this causes the difference frequency to alternate between two discrete positions (see Fig. 2).

In the receiver, the two noise bands are multiplied together. Following the multiplier are two integrating filters which are tuned to the two possible difference frequencies. The out-

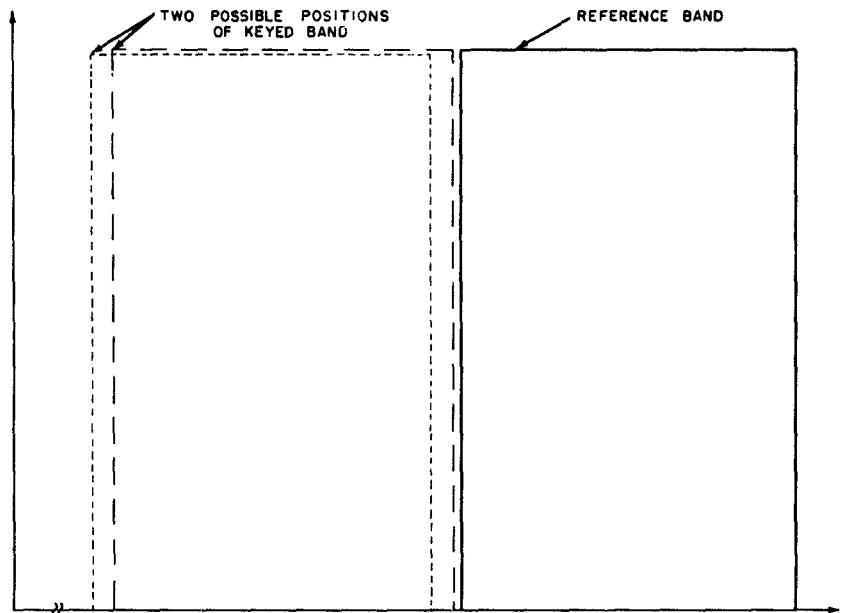

Fig. 2. Idealized reference and keyed band spectra.

puts of these two filters are continually compared, and the output binary symbol corresponds to the filter having the larger output.

In the channel, jamming signals were added to the transmitted signal. The power ratio of these two signals at the input to the receiver was the independent variable in most of our tests; the dependent variable was the relative frequency of error. The stored-reference system (see Fig. 1) was tested as a linear system and with limiters before the band-pass filter in the receiver (see points X in Fig. 1). A phase-modulated system was simulated by limiting the transmitted signals (at the points Y). The limiters removed the amplitude variations of the noise bands from the transmitted signal but did not affect the phase variations.

The transmitted-reference system (Fig. 1) was tested as a linear system and with limiters (at the points Z in Fig. 1).

These several kinds of jamming signals were chosen because they were reasonably representative:

Gaussian Noise: An independent Gaussian noise had the same bandwidth as the signal noise bands in the channel.

Sine Wave: An unmodulated carrier was placed in frequency approximately at the center of the keyed noise band.

AM Sine Wave: A carrier was placed at the center of the keyed noise band and was 100 per cent amplitude-modulated with a 1000-cps tone.

SECRET

Two-Tone: A sinusoidal carrier was placed approximately at the center of each band spectrum. The frequency difference between carriers was one of the two symbol difference frequencies.

III. DESCRIPTION OF EQUIPMENT

The block diagram for the transmitted-reference NOMAC system is shown in Fig. 3. The stored-reference NOMAC system is identical except that: (a) there is no adder network in the output of the transmitter, (b) the reference channel is connected directly to the input of the reference band filter, and (c) the jamming is added only to the keyed channel. In setting up this system, certain constants (e.g., bandwidth, center frequency, and data rate) were arbitrarily chosen for convenience.

The major components of the system (see Fig. 3) are:

A. Transmitter Section

(1) The three oscillators (50.5 kcps, 48.5 kcps, and 3020 kcps) are standard crystal-controlled oscillators.

(2) The keyer is an electronic switch which selects one of the two oscillator outputs (48.5 kcps or 50.5 kcps) according as a space or a mark is to be transmitted. The binary output consists of alternating marks and spaces. (A sequence like this may be expected to produce more errors than any other sequence since it results in more intersymbol interference.)

The symbol duration is 10 milliseconds; that is, for our particular "square wave" binary input, the keyer output is a 48.5-kcps sine wave for 10 ms, then a 50.5-kcps sine wave for the next 10 ms, and so forth.

(3) The three mixers are balanced crystal modulators. They are operated in the standard "suppressed carrier" method so that the input frequencies do not appear at the output.

(4) The noise source is a 6D4 tube oriented in a magnetic field. Its output noise is Gaussian and its spectrum is essentially flat to 1 Mcps. The noise is sent through a 6-pole Tchebycheff band-pass filter whose frequency characteristic is shown in Fig. 4. The spectrum of the transmitter output is shown in Fig. 5.

(5) The adder consists of a simple Y-connected resistor adding network.

B. Channel Section

(1) Several different jamming signals are used. For noise jamming, another 6D4 tube oriented in a magnetic field generates a noise statistically independent of the signal. Sine wave (CW and 100 per cent modulated at 1000 cps) jamming is obtained from G. R. 805-C standard signal generator. "Two-tone jamming" is obtained from two G. R. 805-C signal generators in conjunction with a balanced crystal mixer. In all cases, the jamming generator is followed by a band-pass filter with a bandwidth and center frequency identical to the complete spectrum of the transmitted signal in the channel. In this way, the effective signal-power to jamming-power ratio can be measured with a power indicating meter.

(2) The attenuators have a range of 0 to 101 decibels in discrete steps of 1 db. Their accuracy is approximately 0.1 db.

(3) The power meter is a thermocouple-type meter (Sensitive Instrument Universal Polyrange), driven by a video amplifier with a very low output impedance.

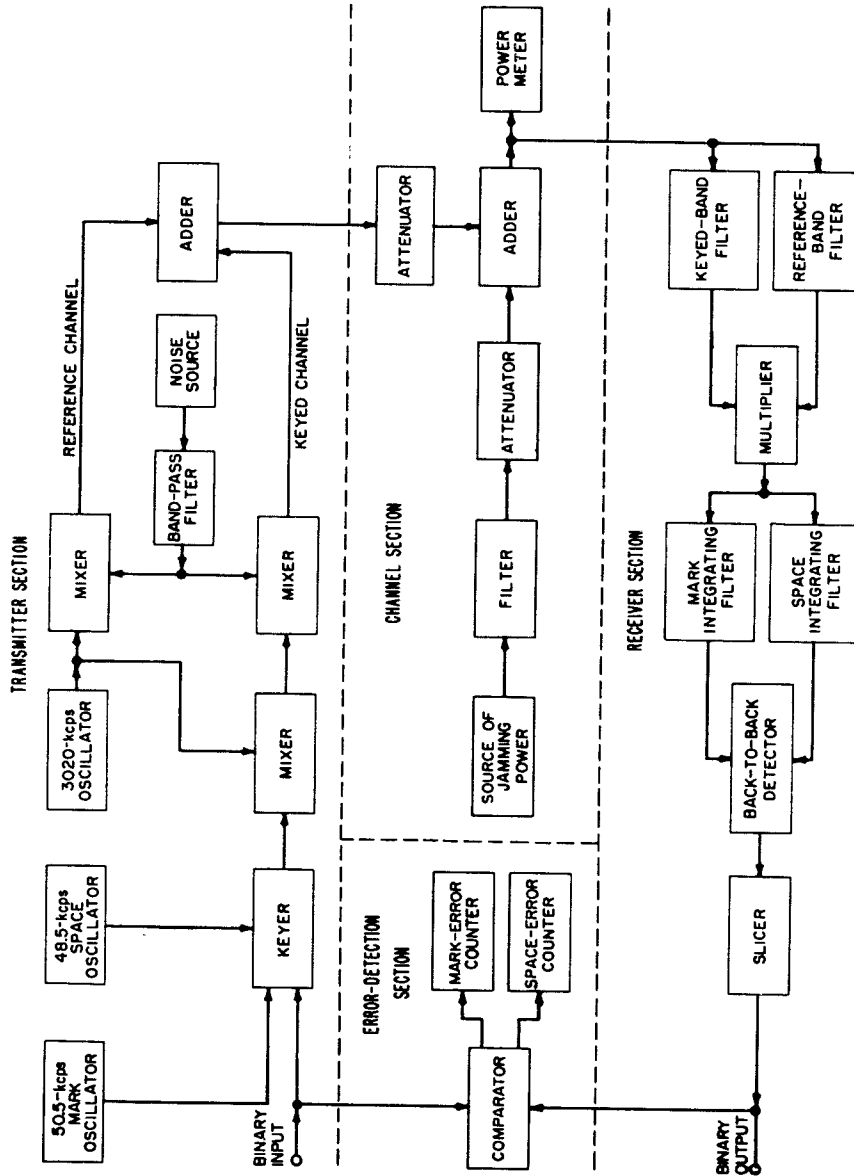

Fig. 3. The NOMAC communication system.

SECRET

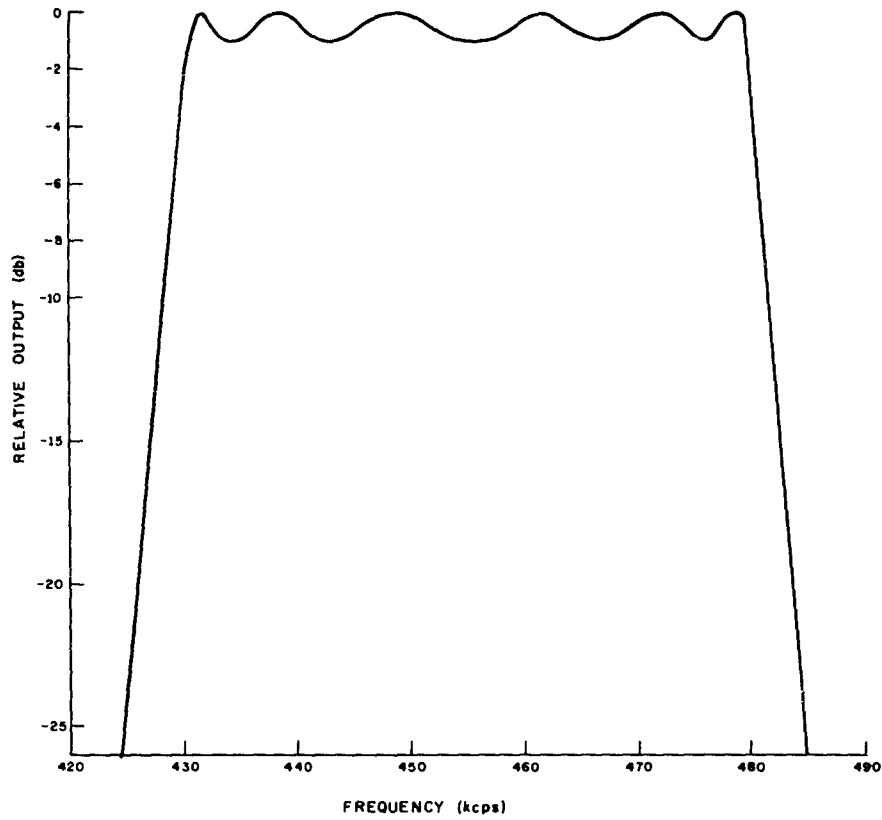

Fig. 4. Frequency characteristic of 6-pole Tchebycheff filter.

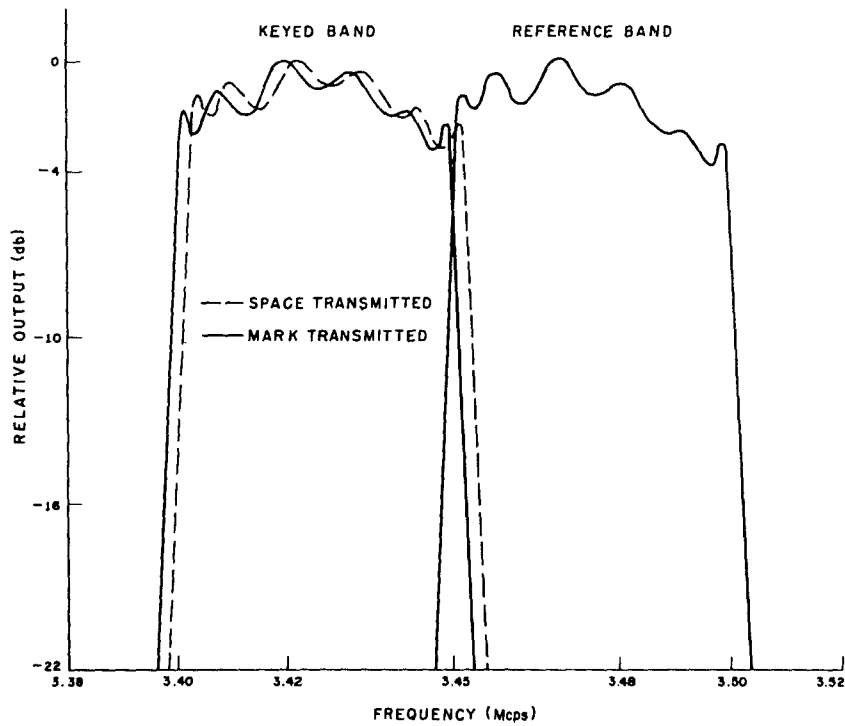

Fig. 5. Spectrum of transmitter output.

SECRET

SECRET

(4) Since only additive jamming is considered in this report, the channel consists of a simple Y-connected resistor adding network.

C. Receiver Section

(1) The keyed- and reference-band filters are 4-pole Butterworth filters. Their frequency characteristics are shown in Fig. 6.

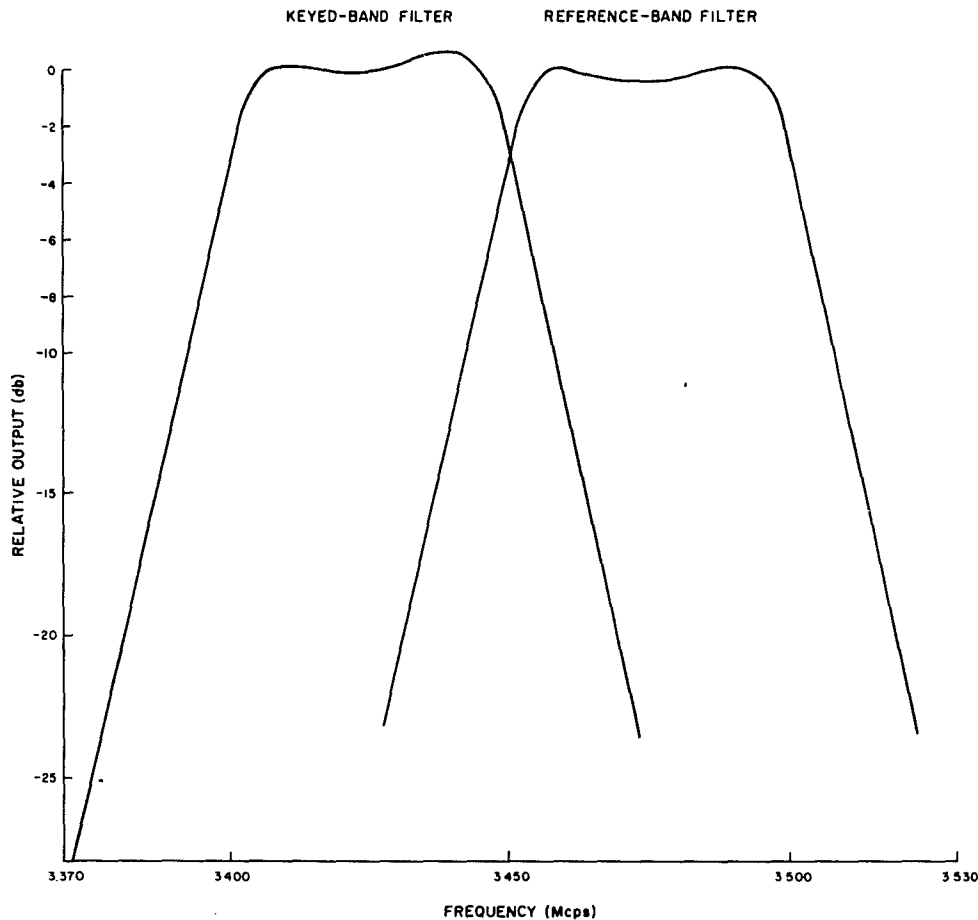

Fig. 6. Frequency characteristics of 4-pole Butterworth band-pass filters.

(2) The multiplier uses a Type 6AS6 tube for the non-linear element.

(3) The integrating filters (or averaging filters) are simple 4-pole filters. All poles are synchronously tuned to the mark or space oscillator frequency (50.5 kcps or 48.5 kcps). The filter frequency characteristics are shown in Fig. 7.

(4) The back-to-back detector is an envelope detector in which the two outputs of the averaging filters (after being detected) are connected together in a differential manner so that the output should be positive if a mark is sent and negative if a space.

(5) This output waveform is cleaned up in a slicer circuit whose input-output characteristic is shown in Fig. 8.

SECRET

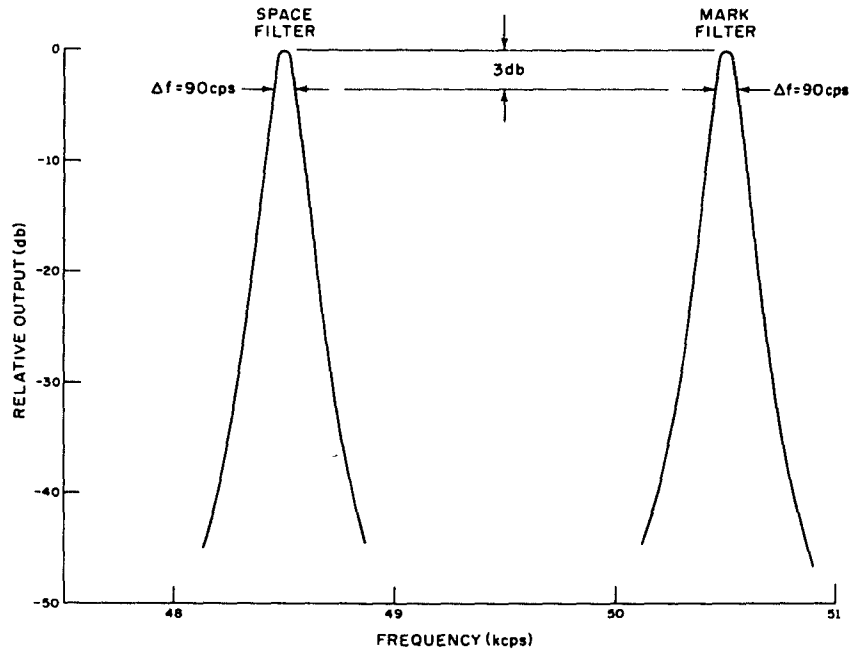

Fig. 7. Frequency characteristics of mark and space integrating filters.

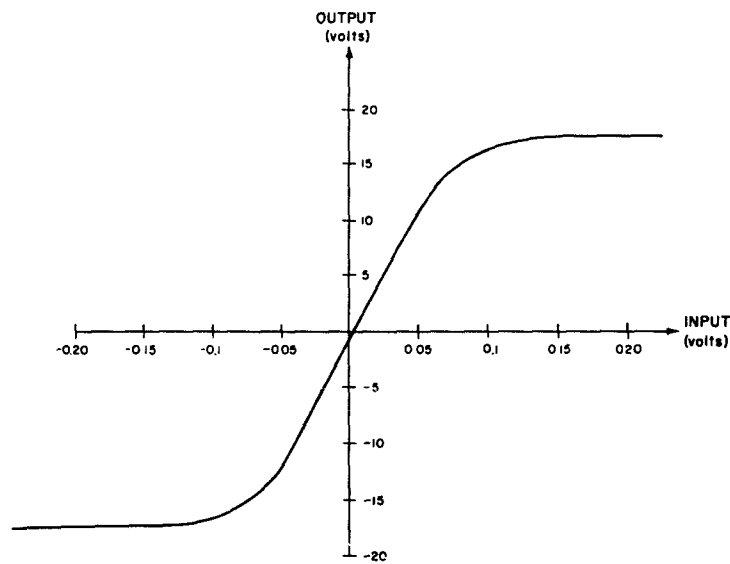

Fig. 8. Slicer transfer characteristic.

SECRET

SECRET

D. Error Detection Section

(1) The comparator compares the symbol input to the transmitter with the output of the receiver slicer circuit. A coincidence tube is gated into operation for a 2-ms interval in the center of the received 10-ms square-wave pulse. If the two inputs to the coincidence tube do not agree during this 2-ms interval, then an error pulse is generated which is fed into a Berkeley 410 counter.

(2) Two separate error counters are provided so that individual mark and space errors can be counted.

E. Limiters

The band-pass limiters, where used, have two Type 6BN6 tubes as the limiting elements and have characteristics as shown in Fig. 9(a) and 9(b). They are tuned to the center frequency of the band that they limit. Their phase characteristic is linear within 1 degree throughout the 100-kcps pass band.

IV. EXPERIMENTAL PROCEDURE

The effective signal-to-jamming power ratio is measured with the power meter by the following method. The jamming power is adjusted so that the power meter reads the same with the jamming alone as with the signal alone. If both are turned on together, the power meter reads 3 db higher than with either one alone. There is now a signal-to-jamming ratio in the channel of 0 db. Any desired signal-to-jamming ratio can be set, for the attenuators have already been calibrated. The accuracy thus obtained is about 1/4 db.

The gains of the integrating filters are adjusted so that the mark and space errors are equally numerous with Gaussian noise jamming at a signal-to-jamming ratio of -10 db for a linear transmitted-reference system. It was found that the ratio of mark errors to space errors varied approximately from 0.8 to 1.2 with Gaussian noise jamming and different signal-to-jamming ratios.

The total number of errors is the sum of the mark and space errors. The relative frequency of error is the ratio of the total number of errors (as indicated by the error counters) to the total number of symbols transmitted. Since 100 symbols are transmitted each second, the total number of symbols transmitted can be easily determined to within an accuracy of better than 0.1 per cent for tests about fifteen minutes long and manual starting and stopping of the tests.

The total number of symbols transmitted for each point on the curves shown in the results varied from a minimum of about 15,000 in the region of large relative frequency of error (approximately 0.5) to 150,000 in the region of small relative frequency of error (approximately 10^{-4}). In all cases, enough symbols were transmitted so that the statistical error was negligible compared to the error in measuring the signal-to-jamming ratio. A comparison of curves of the same tests run on different days verified this assertion.

The over-all reproducible accuracy of the results presented in this report is 1/2 db.

V. RESULTS AND DISCUSSION

The results are shown in a number of curves of Figs. 10 through 17. The abscissa

SECRET

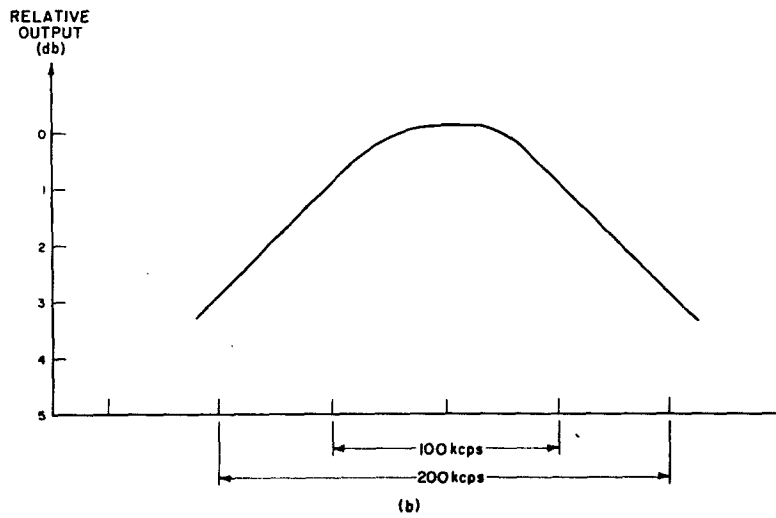
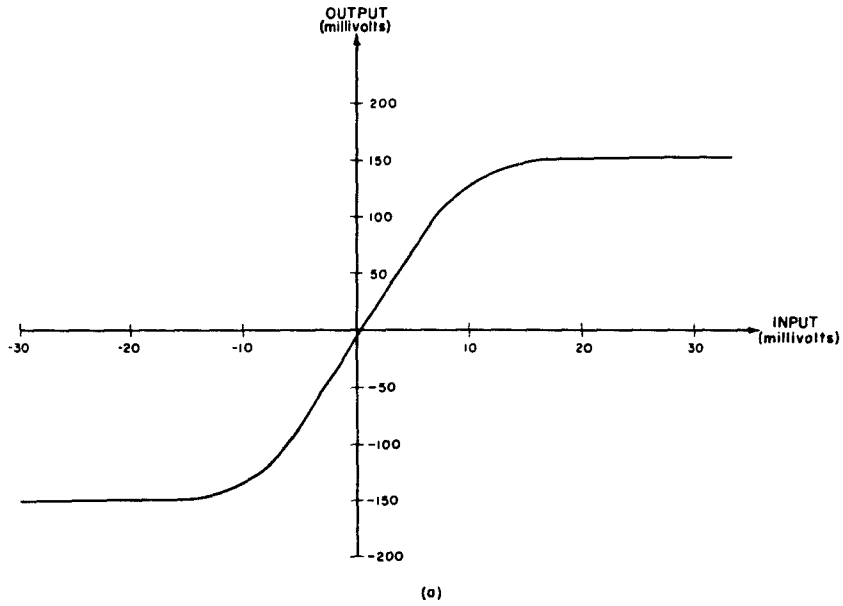

Fig. 9. Band-pass limiters; (a) transfer characteristic, (b) frequency characteristic.

SECRET

SECRET

is the ratio of signal power to jamming power in db, increasing to the right. The ordinate is the relative frequency of error on a logarithmic scale, increasing upward.

Thus, if of two curves the first lies entirely to the right of the second, the first represents either a less efficient system or a more effective jamming signal than the second.

Included with each curve is a block diagram of the system that was tested.

A. Stored-Reference

Figures 10, 11, 12 and 13 show the stored-reference systems, each tested against noise and sine-wave jamming.

Figure 10 shows the linear stored-reference system.

Figure 11 shows the stored-reference system with limiters preceding the band-pass filters.

Figure 12 shows the linear phase-modulated system.

Figure 13 shows the phase-modulated system with limiters preceding the band-pass filters.

The curves of Figs. 10 and 12 are approximately coincidental; thus, for a linear receiver, sine wave and noise jamming are equally effective. The curves of Figs. 10 and 12 lie to the left of those in Figs. 11 and 13; thus, the presence of limiters in the receiver was only detrimental. These curves indicate that noise jamming was approximately 1.5 db more effective against the system employing limiters in the receiver than those without. Sine-wave jamming become 5.5 db more effective against the stored-reference system and 6.5 db more effective against the phase-modulated system after limiters were added to the linear systems.

The fact that sine-wave jamming was more effective than noise jamming when limiters were used in the receiver may be attributed to the well-known "capture" effect of limiters.

We may conclude that (1) limiters should not be used in the receiver prior to the multiplier for stored-reference systems; (2) sine-wave is as effective as noise jamming, unless limiters are used in the receiver; then sine-wave jamming is more effective.

B. Transmitted-Reference

Figures 14, 15, 16 and 17 show the transmitted-reference systems.

Figure 14 shows the linear transmitted-reference system tested against noise, sine-wave, and two-tone jamming.

Figure 15 shows the transmitted-reference system with a limiter preceding the band-pass filters tested against noise, sine-wave, modulated sine-wave, and two-tone jamming.

Figure 16 shows the transmitted-reference system with limiters following the band-pass filters tested against noise, sine-wave, and two-tone jamming.

Figure 17 shows the transmitted-reference system with limiters both preceding and following the band-pass filters tested against noise and two-tone jamming.

As with the stored-reference systems, the presence of limiters was only detrimental (compare curves of Fig. 14 with the corresponding curves in Figs. 15, 16 and 17).

However, a comparison of Fig. 16 with Figs. 15 and 17 shows that jamming is less effective against the system employing limiters following the band-pass filters than it is against the systems employing limiters in other ways.

SECRET

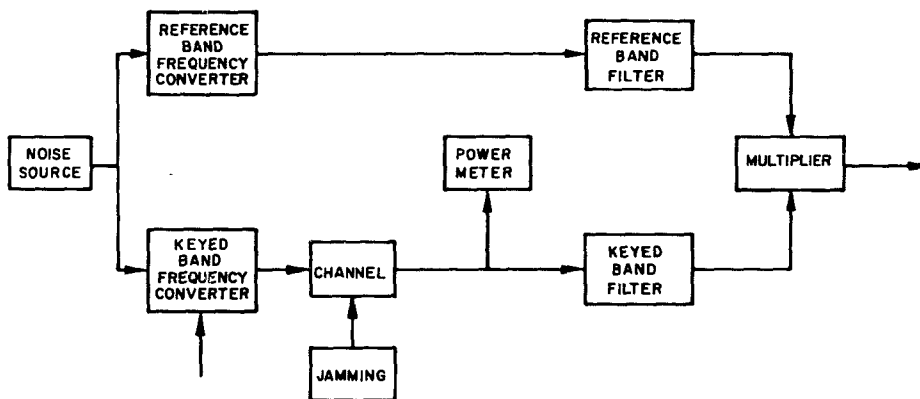
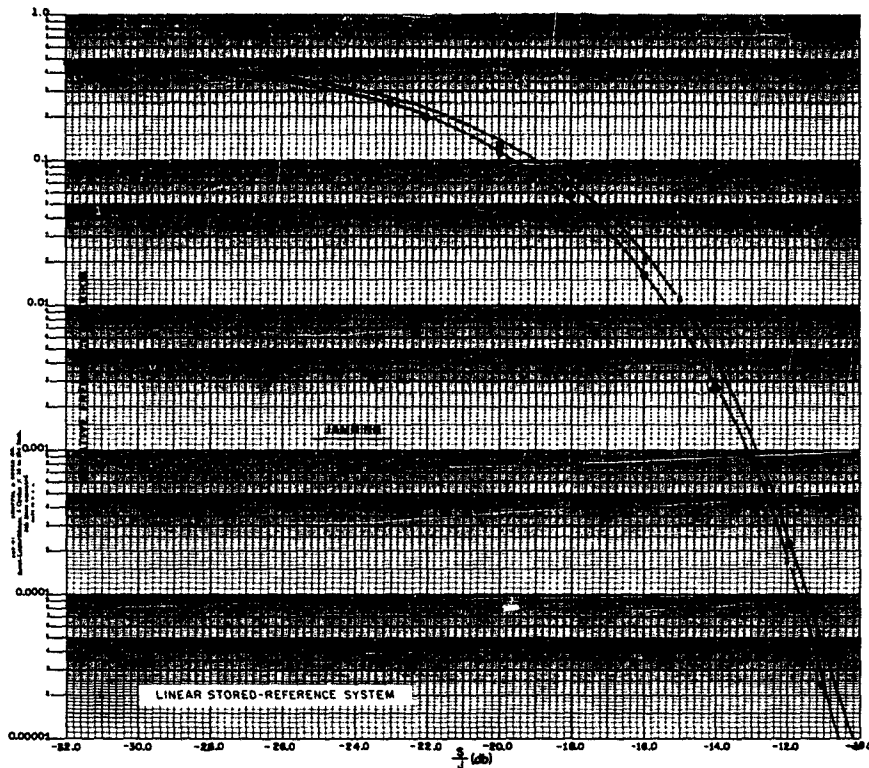

Fig. 10. Linear stored-reference system.

SECRET

SECRET

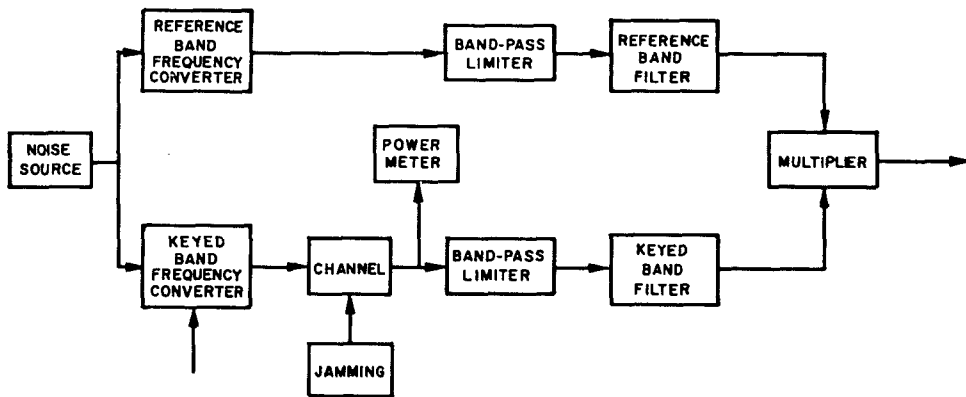
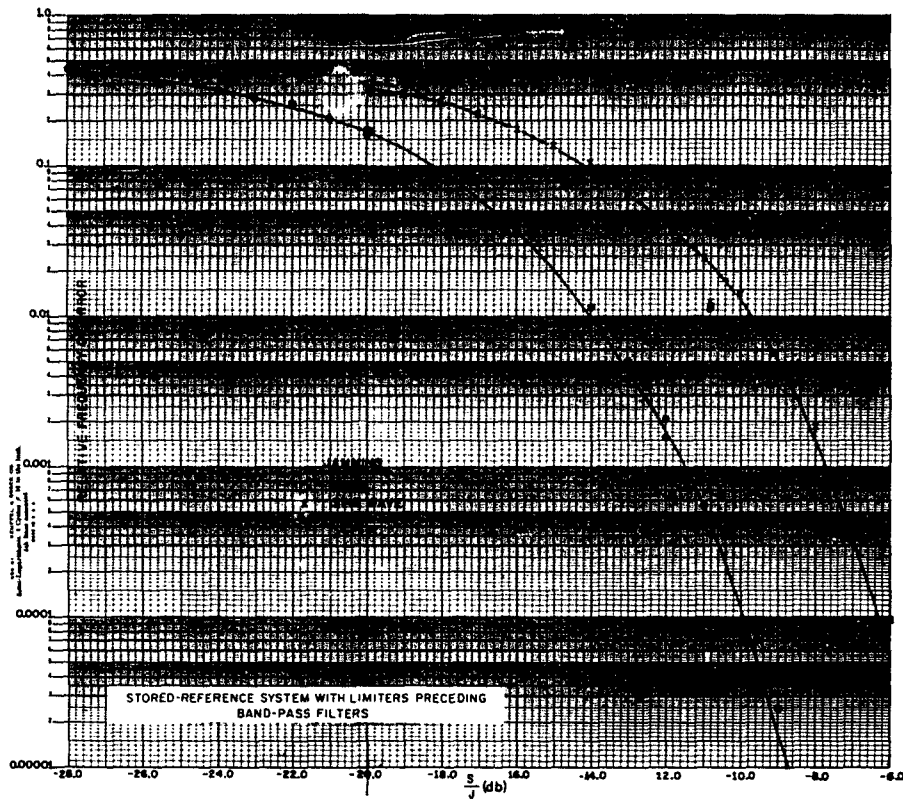

Fig. 11. Stored-reference system with limiters preceding band-pass filters.

SECRET

SECRET

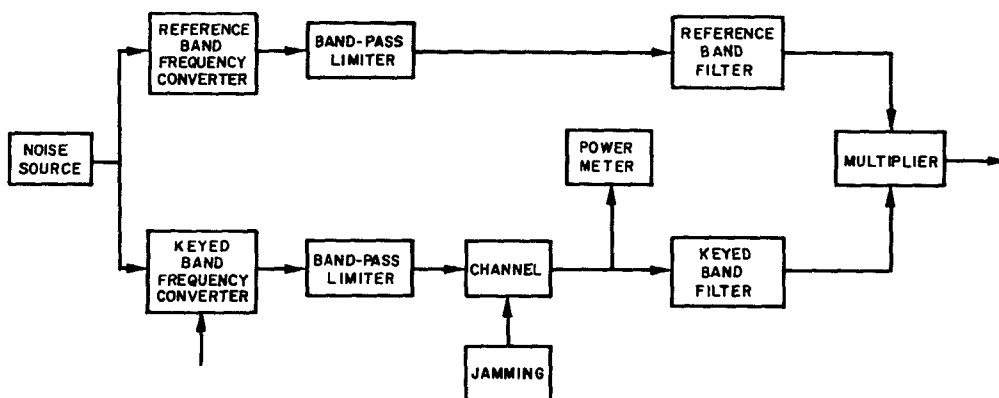
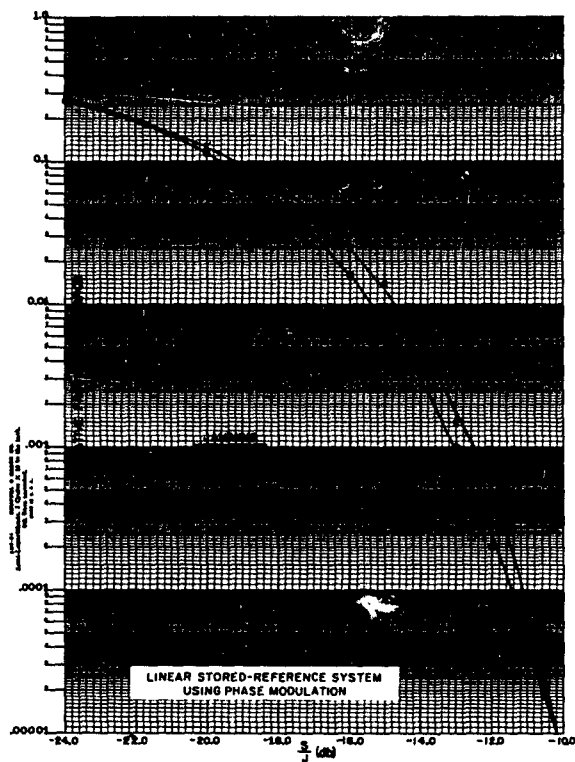

Fig. 12. Linear stored-reference system using phase modulation.

SECRET

SECRET

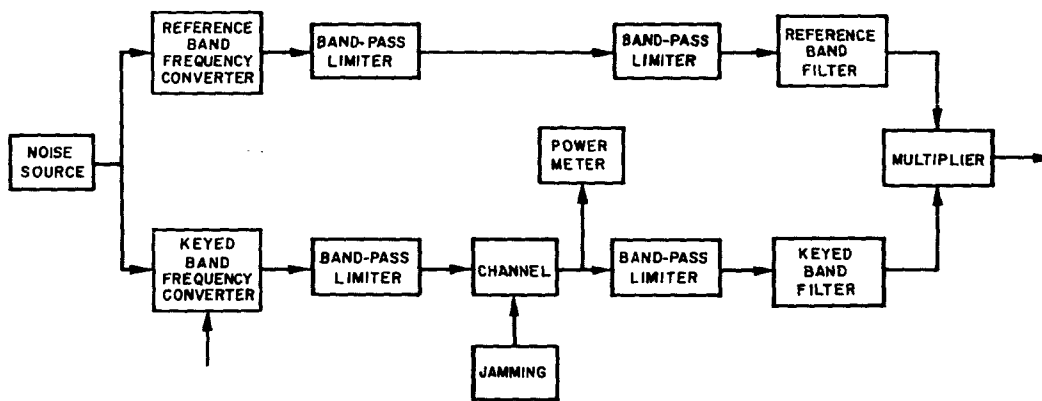
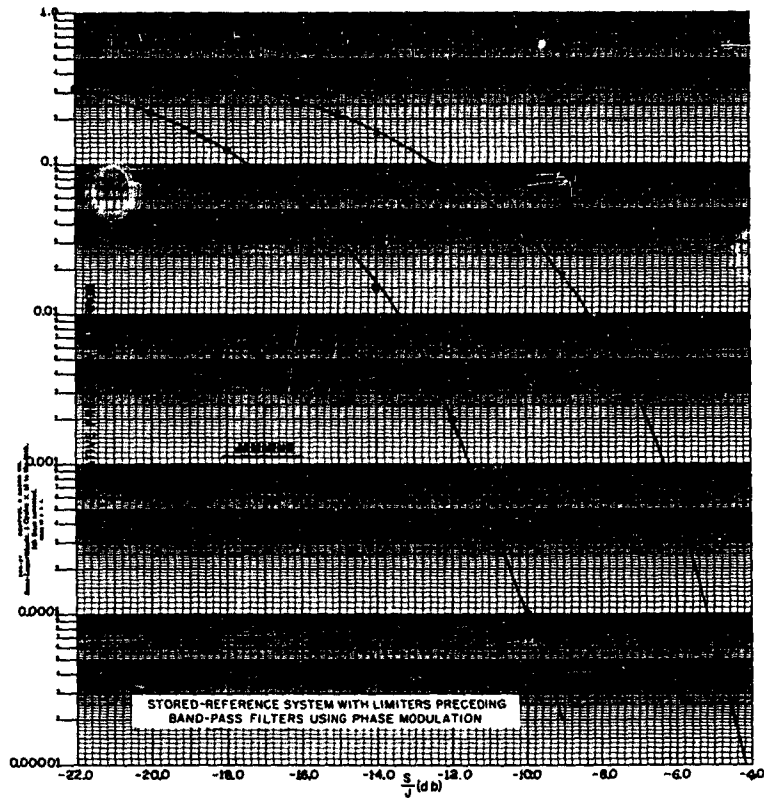

Fig. 13. Stored-reference system with limiters preceding band-pass filters using phase modulation

SECRET

SECRET

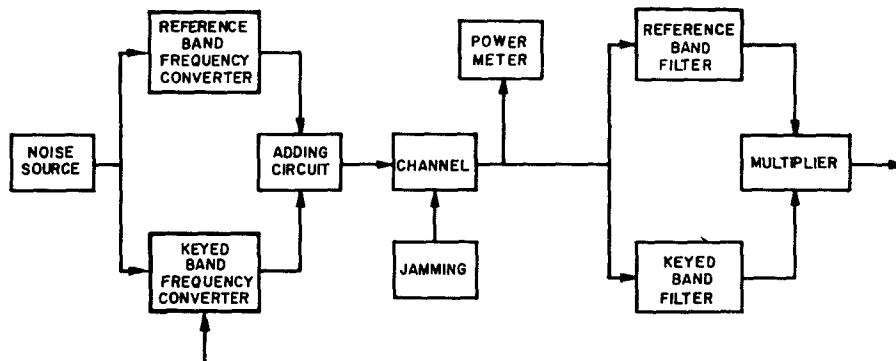
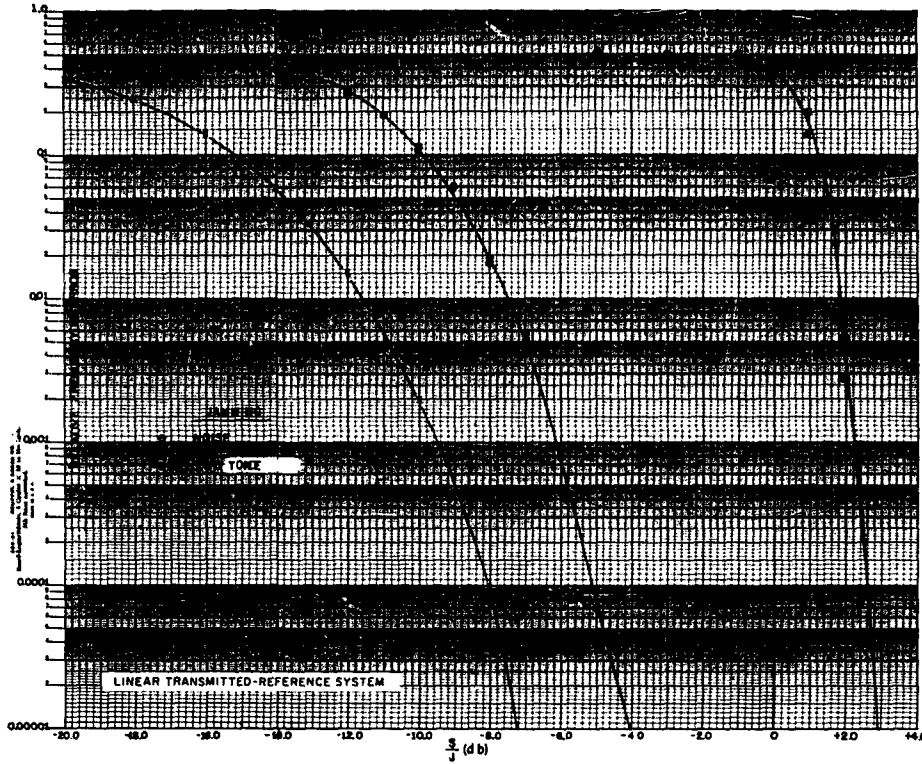

Fig. 14. Linear transmitted-reference system.

SECRET

SECRET

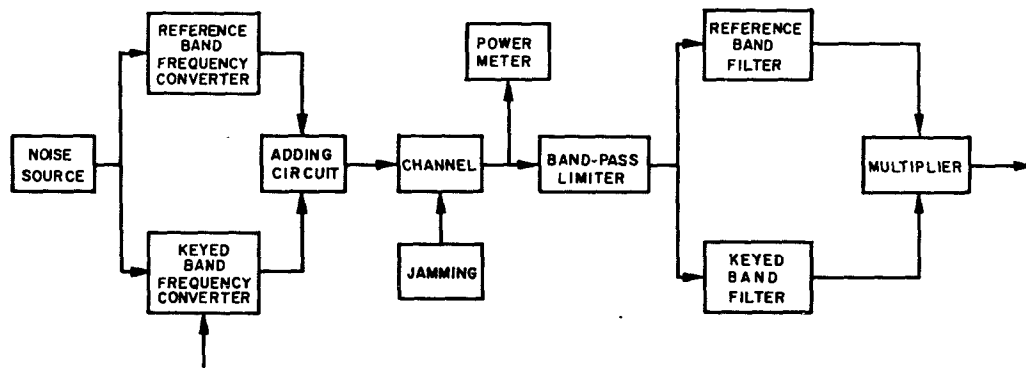
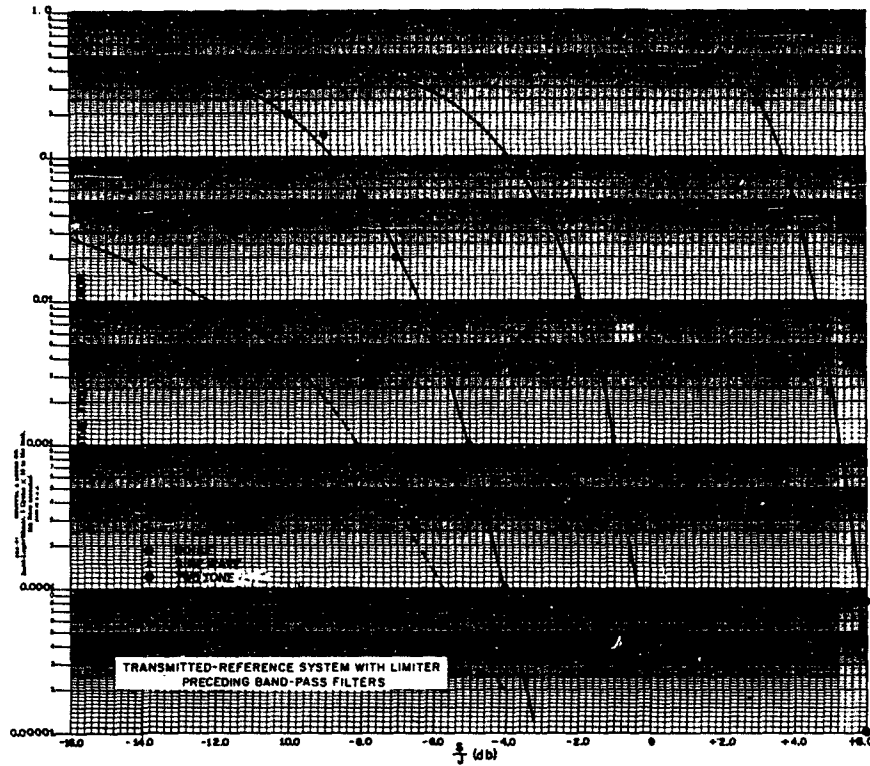

Fig. 15. Transmitted-reference system with limiters preceding band-pass filters.

SECRET

SECRET

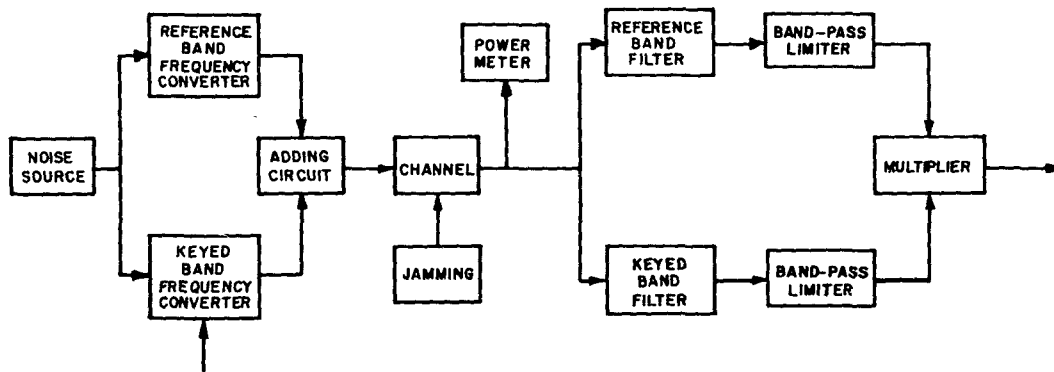
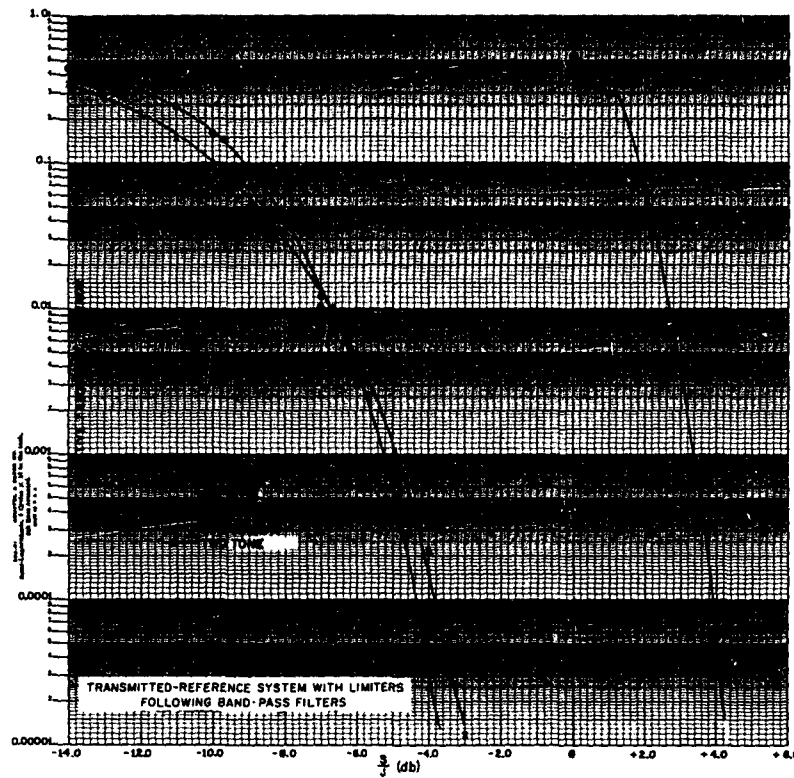

Fig. 16. Transmitted-reference system with limiters following band-pass filters.

SECRET

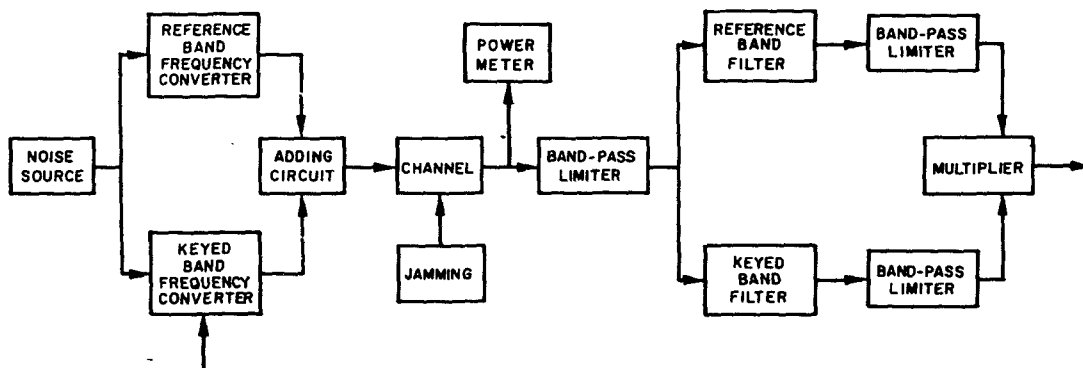
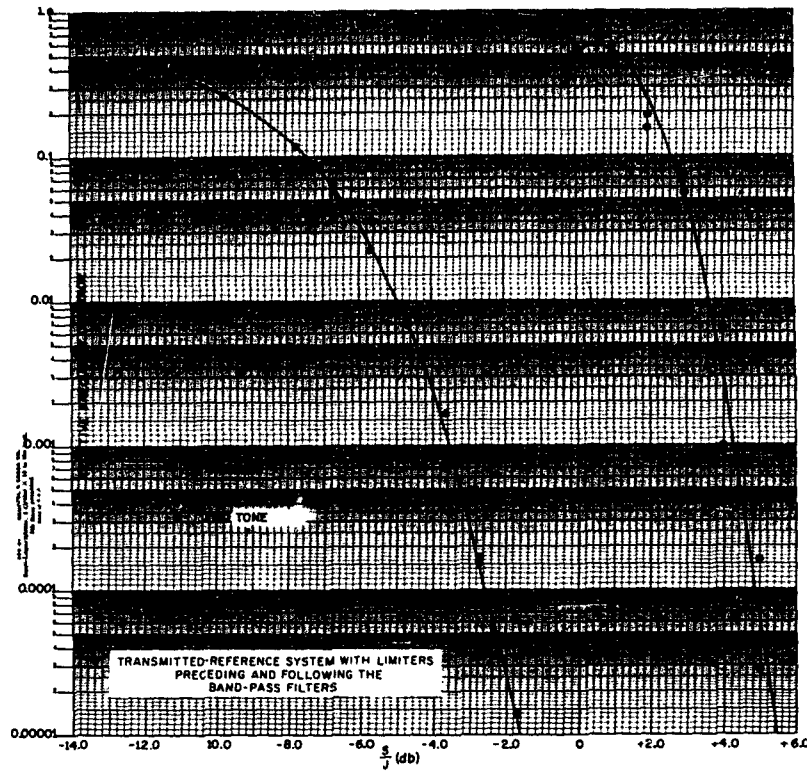

Fig. 17. Transmitted-reference system with limiters preceding and following band-pass filters.

SECRET

The increased effectiveness of jamming on the most satisfactory system with limiters as compared to the linear system is as follows: for noise jamming, +1 db; for sine-wave jamming, +4.5 db; and for two-tone jamming, +1 db.

When limiters were used, sine-wave jamming was always at least as effective as noise jamming (Figs. 15, 16 and 17). Without limiters, noise was more effective than sine-wave jamming.

Jamming by a single sine wave affects the linear stored-reference system and the linear transmitted-reference system in the same manner. In the stored-reference system, the signal power in the channel originates from the keyed band alone. In the transmitted-reference system, the signal power, measured in the channel, originates equally from the keyed and reference bands. Since the jamming sine wave is in the keyed band, we may expect a 3-db difference when comparing the effectiveness of sine-wave jamming of these two systems. Accordingly, the curves for sine-wave jamming of Figs. 10 and 14 have the same shape and differ by approximately 3 db.

Two-tone jamming is vastly more effective than any other kind in all cases (Figs. 14, 15, 16 and 17). Every system needs at least +3 db S/J ratio to work at all well against this kind of interference.

Other tests presented in Appendix II show that two-tone jamming is most effective when the tones differ by one of the two symbol difference frequencies.

We may conclude that (1) for best operation, limiters should not be used prior to the multiplier in transmitted-reference systems; (2) if limiters must be used, they should follow the band-pass filters; and (3) the most effective jamming signal is two tones separated by one of the difference frequencies.

C. Stored-Reference and Transmitted-Reference Systems Compared

Table I shows the adjusted db difference of S/J ratios needed for a relative frequency of error of 0.1 per cent and for the best of each class of systems. The error curve for the stored-reference system does not depend on the type of jamming.

TABLE I

	$(S/J)_{SR}$	$(S/J)_{TR}$	Adjusted $(S/J)_{SR} - (S/J)_{TR}$ to compare systems on equal bandwidth basis
Sine-Wave Jamming	-12.9 db	-9.5 db	- 6.4 db
Noise Jamming	-12.9	-6.1	- 9.8
Two-Tone Jamming	-12.9*	+2.2	-18.1

*This value was not actually measured because two-tone jamming is here equivalent to sine-wave jamming.

Note that the effective channel bandwidth of the stored-reference system is just half that of the transmitted-reference system because of the experimental setup. Theoretically, this

SECRET

gives an advantage of 3 db to the transmitted-reference system; hence, 3 db has been subtracted from $(S/J)_{SR} - (S/J)_{TR}$ to permit comparison on the basis of equal channel bandwidth.

We are not so sanguine that we may expect an enemy not to realize the effectiveness of two-tone jamming. We must therefore conclude that the last figure in the table, -18.1 db, represents, for our particular models, the invulnerability of a stored-reference system relative to a transmitted-reference system, that is, a stored-reference system is enormously less vulnerable to jamming.

D. Theoretical Studies

The results agree with what is expected theoretically; a precise theoretical analysis is being done elsewhere and will appear as a separate report.

VI. CONCLUSIONS

The important conclusions are unequivocal: (a) Stored-reference systems are much less vulnerable to jamming than transmitted-reference systems. (b) Two-tone jamming is the most effective against transmitted-reference systems, and the kind of jamming is immaterial against stored-reference systems. (c) Limiters used prior to the multiplier in the receiver are always detrimental to performance under jamming. (d) In the transmitted-reference systems, if limiters are to be used prior to the multiplier, they should follow the band-pass filters.

ACKNOWLEDGMENTS

We gratefully acknowledge help, in building the experimental system, by: T. Sarantos, E. Casazza, R. Gay, J. MacMillan, W. J. McLaughlin. Valuable discussions were held with Dr. W. B. Davenport, Jr.

REFERENCES

1. B.L. Basore, "Noise-Like Signals and Their Detection by Correlation" (SECRET), Technical Report No. 7, Lincoln Laboratory, M.I.T. (26 May 1952).
2. B.J. Pankowski, "Multiplexing a Radio Teletype System Using a Random Carrier and Correlation Detection" (SECRET), Technical Report No. 5, Lincoln Laboratory, M.I.T. (May 1952).
3. Quarterly Progress Report, Division 3 (SECRET), Lincoln Laboratory, M.I.T. (October 1952).

SECRET

APPENDIX I

SINE-WAVE JAMMING AS A FUNCTION OF FREQUENCY

Sine-wave jamming tests were conducted on a linear stored-reference system (see block diagram of Fig. 10) to determine the effectiveness of various jamming frequencies. Figure 18 shows a plot of signal-to-jamming ratio as a function of frequency for several constant values of frequency of error.

These curves are directly related to the transmitter output spectrum shown in Fig. 5 and the receiver band-pass filter characteristic shown in Fig. 6. Hence, it is only to be expected that the jamming effectiveness should be greatest within the keyed band and should fall off rapidly just outside this spectral region.

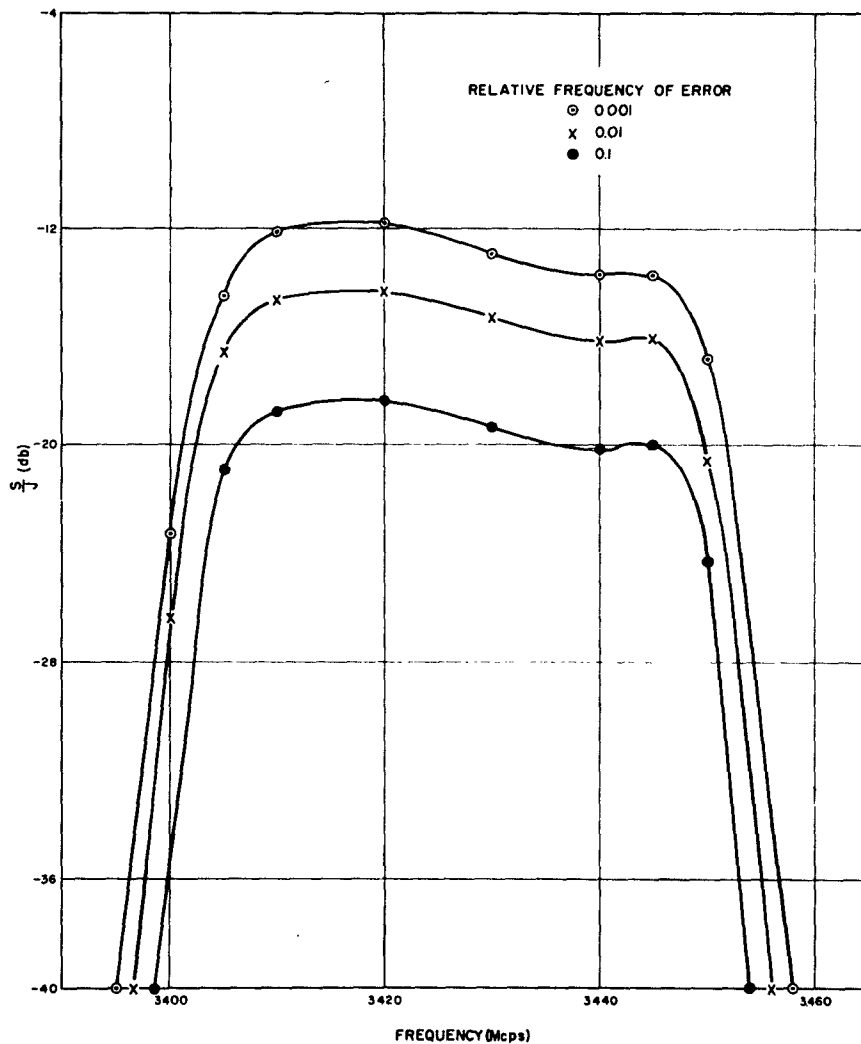

Fig. 18. Signal-to-jamming ratio as a function of frequency for constant relative frequency of error.

SECRET

APPENDIX II

TWO-TONE JAMMING AT VARIOUS DIFFERENCE FREQUENCIES

Tests were conducted on the transmitted-reference system to determine the manner in which the effectiveness of two-tone jamming depended on the frequency spacing between the two jamming sinusoids. Both the linear system and the system with a limiter preceding the band-pass filters were tested (see block diagrams of Figs. 14 and 15.)

Results for the two systems are presented in Figs. 19 and 20. The particular frequency difference used for each curve is indicated. In addition, the relative level of attenuation of the mark integrating filter at this frequency is also shown.

As expected, the transmitted-reference system was most effectively jammed when the frequency difference of the jamming sinusoids corresponded to the resonant frequency of the integrating filter. The use of a limiter in the system increased the effectiveness of the jamming to about 3 db above that obtained with the linear system. However, the limiter did not alter the manner in which jamming effects varied as a function of the two-tone spacing.

SECRET

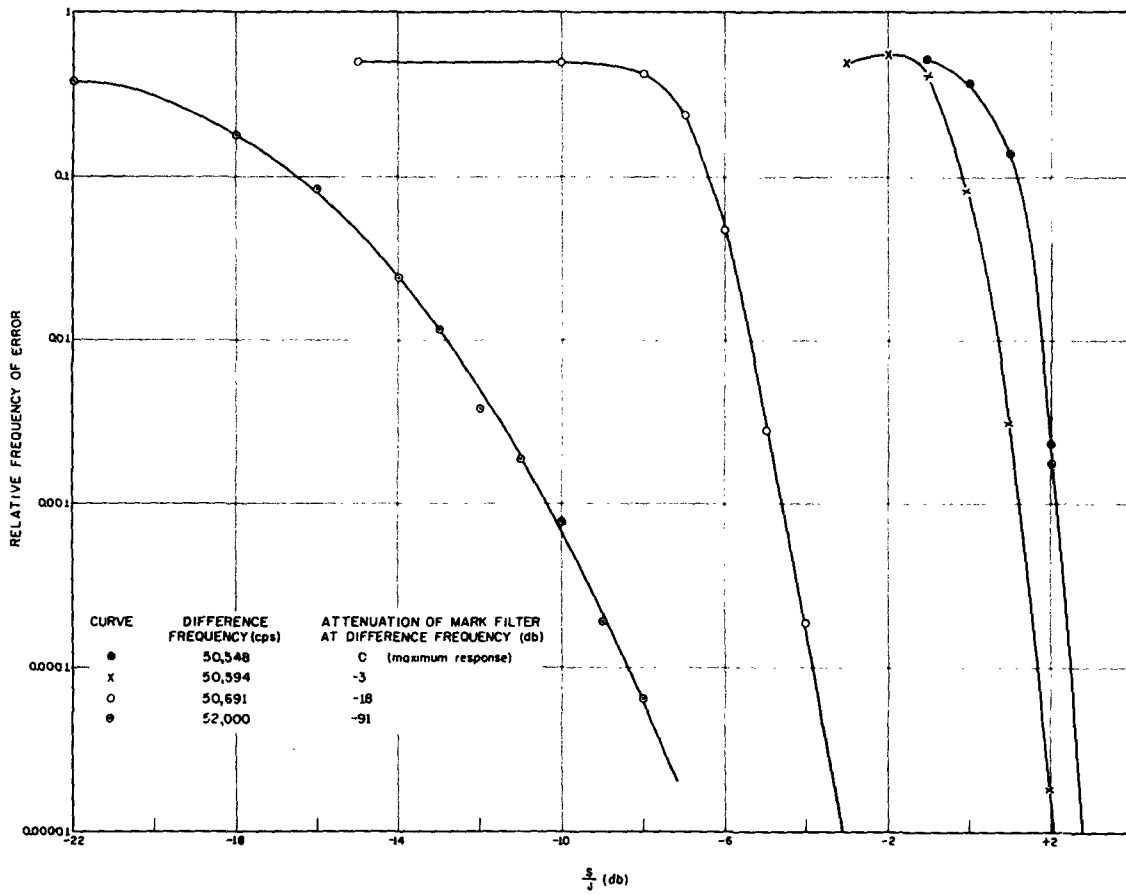

Fig. 19. Linear transmitted-reference system subjected to two-tone jamming.

SECRET

SECRET

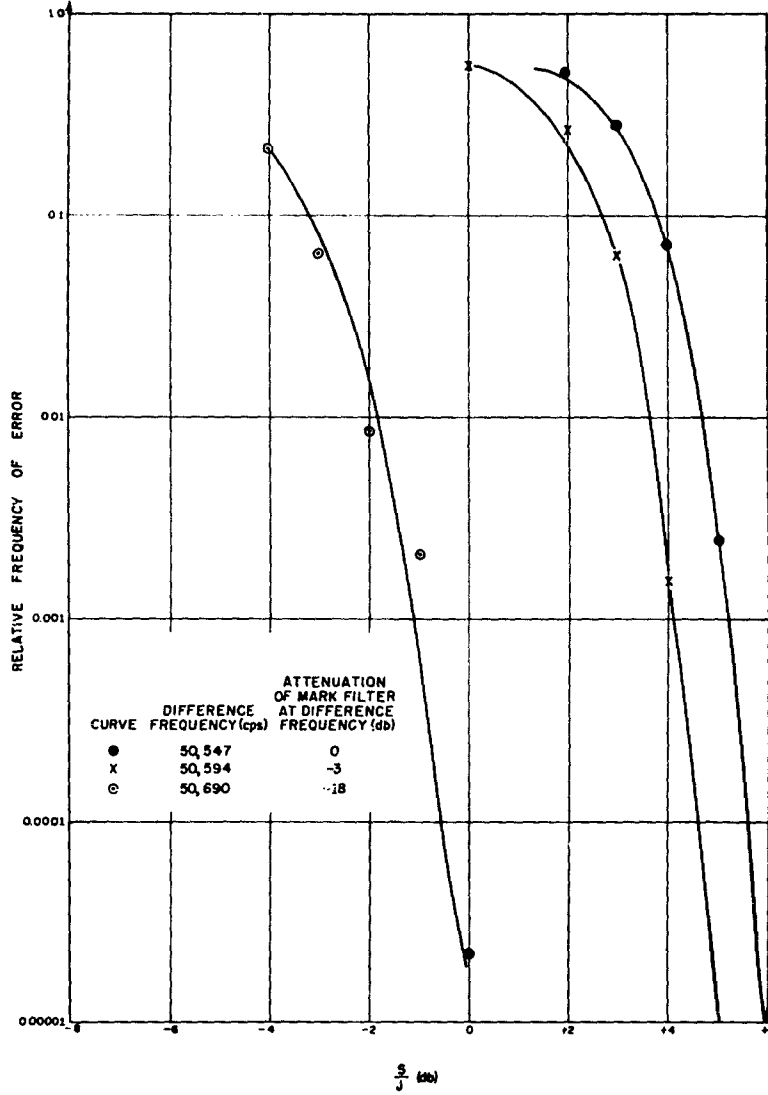

Fig. 20. Transmitted-reference system with limiter preceding band-pass filters subjected to two-tone jamming.

SECRET