

THIS REPORT HAS BEEN DELIMITED  
AND CLEARED FOR PUBLIC RELEASE  
UNDER DOD DIRECTIVE 5200.20 AND  
NO RESTRICTIONS ARE IMPOSED UPON  
ITS USE AND DISCLOSURE,

DISTRIBUTION STATEMENT A

APPROVED FOR PUBLIC RELEASE;  
DISTRIBUTION UNLIMITED.

UNCLASSIFIED

AD 20492

DEFENSE DOCUMENTATION CENTER

FOR

SCIENTIFIC AND TECHNICAL INFORMATION

CAMERON STATION ALEXANDRIA, VIRGINIA



UNCLASSIFIED

NOTICE: When government or other drawings, specifications or other data are used for any purpose other than in connection with a definitely related government procurement operation, the U. S. Government thereby incurs no responsibility, nor any obligation whatsoever; and the fact that the Government may have formulated, furnished, or in any way supplied the said drawings, specifications, or other data is not to be regarded by implication or otherwise as in any manner licensing the holder or any other person or corporation, or conveying any rights or permission to manufacture, use or sell any patented invention that may in any way be related thereto.

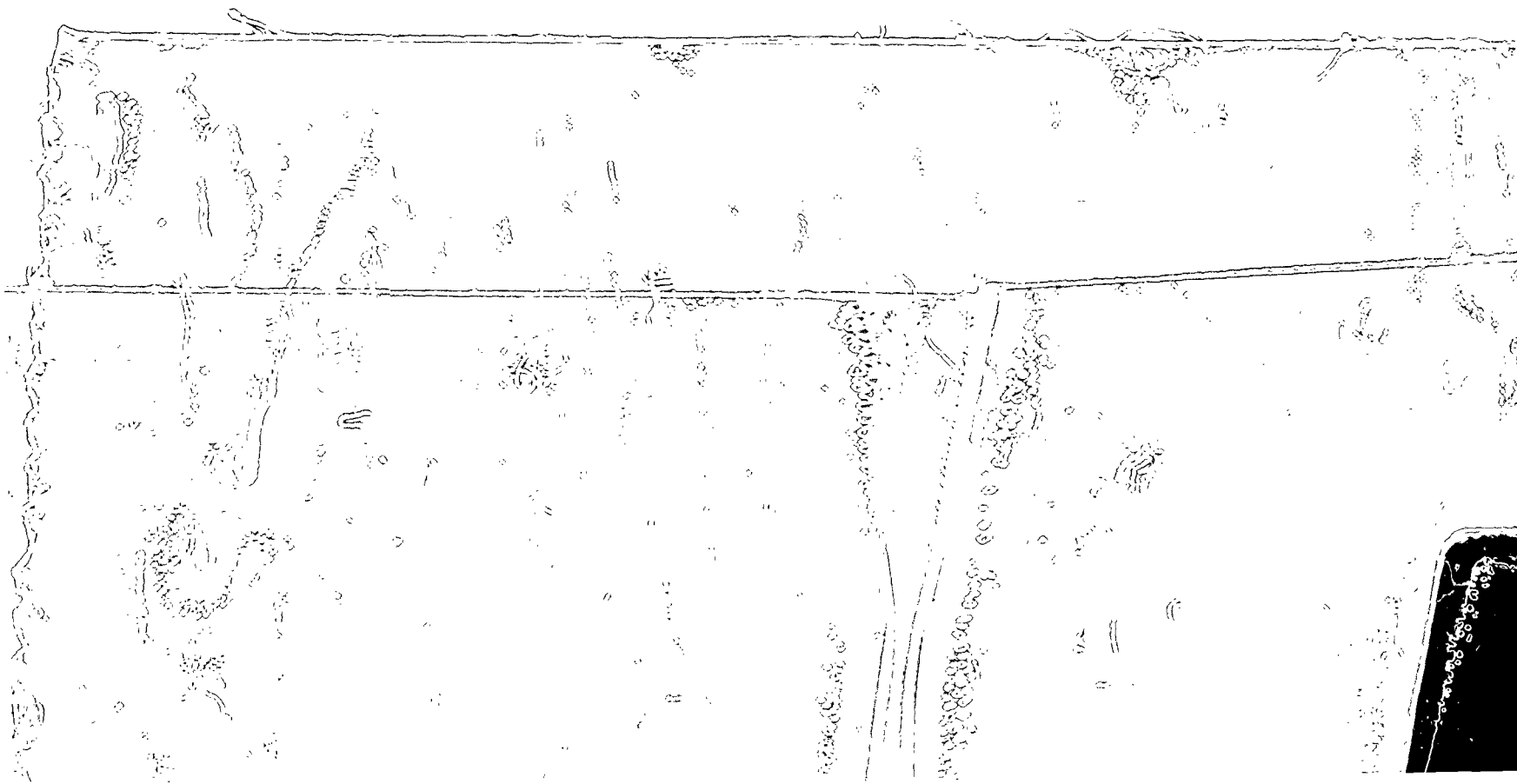

DD FORM 144A

NO. FILE UNIT

OFFICE OF NAVAL RESEARCH

Contract Nonr -562(05)

Technical Report No. 2

Radar Range Tracking and Noise

by

J. P. Ruina

(Brown University)

DIVISION OF ENGINEERING

BROWN UNIVERSITY

PROVIDENCE, R. I.

September 1953

OFFICE OF NAVAL RESEARCH

Contract Nonr-562(05)

Technical Report No. 2

Radar Range Tracking and Noise

by

J. P. Ruina

(Brown University)

DIVISION OF ENGINEERING

BROWN UNIVERSITY

PROVIDENCE, R.I.

September 1953

# RADAR RANGE TRACKING AND NOISE

## Table of Contents

	Abstract	Page
I	Automatic Range Tracking	2
II	Mean Square Error	7
III	Another Criterion for System Optimization	9
IV	Probability of Target Loss	11
V	Appendices	
	A - Solution of the Fokker Planck Equation in an Infinite Interval	19
	B - Solution of the Fokker Planck Equation in a Finite Interval--Low Signal to Noise Ratio	21
	C - Solution of the Fokker Planck Equation in a Finite Interval--Higher Signal to Noise Ratio	24
	D - Some Tabulated Results	31
	Bibliography	34

ABSTRACT

This report presents an analysis of radar range tracking in the presence of noise. Three approaches to the problem are presented. The first (Section II) uses the mean square error criterion to obtain an optimum system. The second (Section III) takes into account the finite range aperture of the system and an optimum system is obtained using a criterion of performance which is more significant for range tracking than the mean square error criterion. In Section IV, a solution is presented for the probability of losing the target in the course of a track. This last analysis presents some mathematical difficulties and seems possible only in a tracking system with position memory.

## RADAR RANGE TRACKING AND NOISE

I. Automatic Range Tracking.

The basic technique used for automatic range tracking involves the comparison of the true target range with the tracking system output, which in general deviates slightly from the true target range. The difference of the two signals controls the system output. The true range  $R$  is usually measured by the time of return of a radar echo and the error is measured by the difference in the time delay of the received echo and a locally generated waveform.\*

A simple block diagram for a tracking system is shown in Figure 1. The transfer functions of the blocks are  $K$  and  $A(s)$ , as indicated where 's' represents the Laplace Transform parameter.

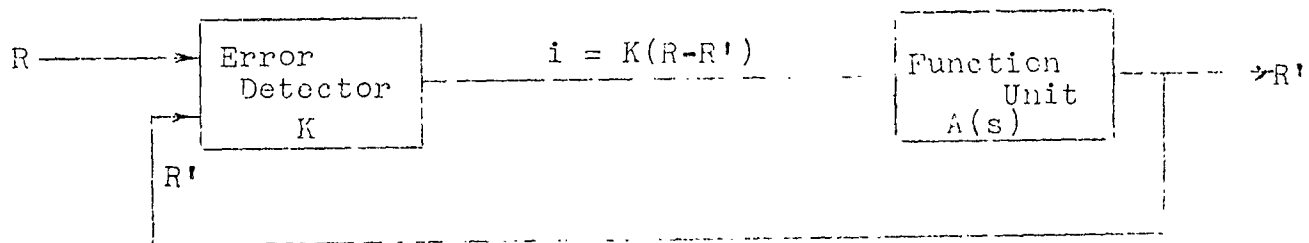

Figure 1

The error detector has an output proportional to the error  $(R-R')$  with a constant of proportionality dependent on signal strength. This can be seen by examining the operation of a typical unit which operates in the manner described below.

Figure 2 shows the transmitted and received pulses as well as two locally generated gates which are delayed in time from the transmitted pulse by an amount  $R'$ . For convenience a range scale rather

---

\*A detailed discussion of radar tracking systems may be found in Reference 1.

OFFICE OF NAVAL RESEARCH

Contract Nonr-562(05)

Technical Report No. 2

Radar Range Tracking and Noise

by

J. P. Ruina

(Brown University)

DIVISION OF ENGINEERING

BROWN UNIVERSITY

PROVIDENCE, R.I.

September 1953

# RADAR RANGE TRACKING AND NOISE

## Table of Contents

	Abstract	Page
I	Automatic Range Tracking	2
II	Mean Square Error	7
III	Another Criterion for System Optimization	9
IV	Probability of Target Loss	11
V	Appendices	
	A - Solution of the Fokker Planck Equation in an Infinite Interval	19
	B - Solution of the Fokker Planck Equation in a Finite Interval--Low Signal to Noise Ratio	21
	C - Solution of the Fokker Planck Equation in a Finite Interval--Higher Signal to Noise Ratio	24
	D - Some Tabulated Results	31
	Bibliography	34

ABSTRACT

This report presents an analysis of radar range tracking in the presence of noise. Three approaches to the problem are presented. The first (Section II) uses the mean square error criterion to obtain an optimum system. The second (Section III) takes into account the finite range aperture of the system and an optimum system is obtained using a criterion of performance which is more significant for range tracking than the mean square error criterion. In Section IV, a solution is presented for the probability of losing the target in the course of a track. This last analysis presents some mathematical difficulties and **seems possible only in a tracking system with position memory.**

## RADAR RANGE TRACKING AND NOISE

### I. Automatic Range Tracking.

The basic technique used for automatic range tracking involves the comparison of the true target range with the tracking system output, which in general deviates slightly from the true target range. The difference of the two signals controls the system output. The true range  $R$  is usually measured by the time of return of a radar echo and the error is measured by the difference in the time delay of the received echo and a locally generated waveform.\*

A simple block diagram for a tracking system is shown in Figure 1. The transfer functions of the blocks are  $K$  and  $A(s)$ , as indicated where 's' represents the Laplace Transform parameter.

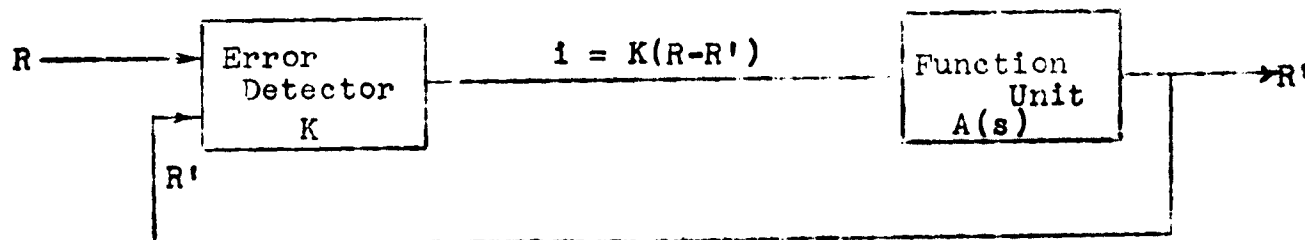

Figure 1

The error detector has an output proportional to the error  $(R - R')$  with a constant of proportionality dependent on signal strength. This can be seen by examining the operation of a typical unit which operates in the manner described below.

Figure 2 shows the transmitted and received pulses as well as two locally generated gates which are delayed in time from the transmitted pulse by an amount  $R'$ . For convenience a range scale rather

---

\*A detailed discussion of radar tracking systems may be found in Reference 1.

than a time scale is used and units of time are converted to their equivalents in range.

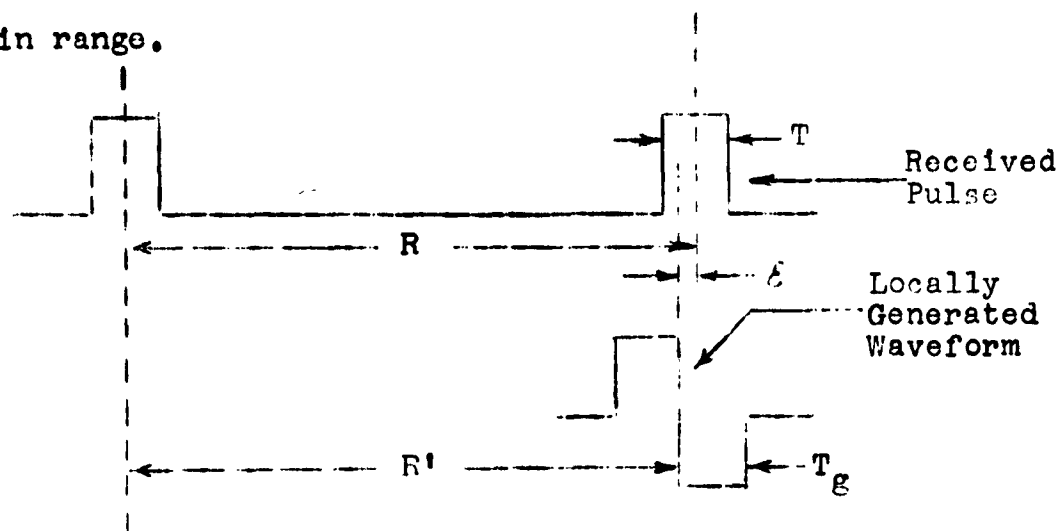

Figure 2

The action of the error detector is to integrate the received signal in the interval of the early gate and then in the interval of the late gate. The difference of these integrals constitutes the error signal. It is clear that the discriminator output depends on both the signal and error amplitudes. Figure 3 shows a series of error detector characteristics for different signal strengths. Experimental curves closely resemble these theoretical characteristics but do not exhibit the discontinuities which are due to the infinite slope of the leading and lagging edges of the pulse.

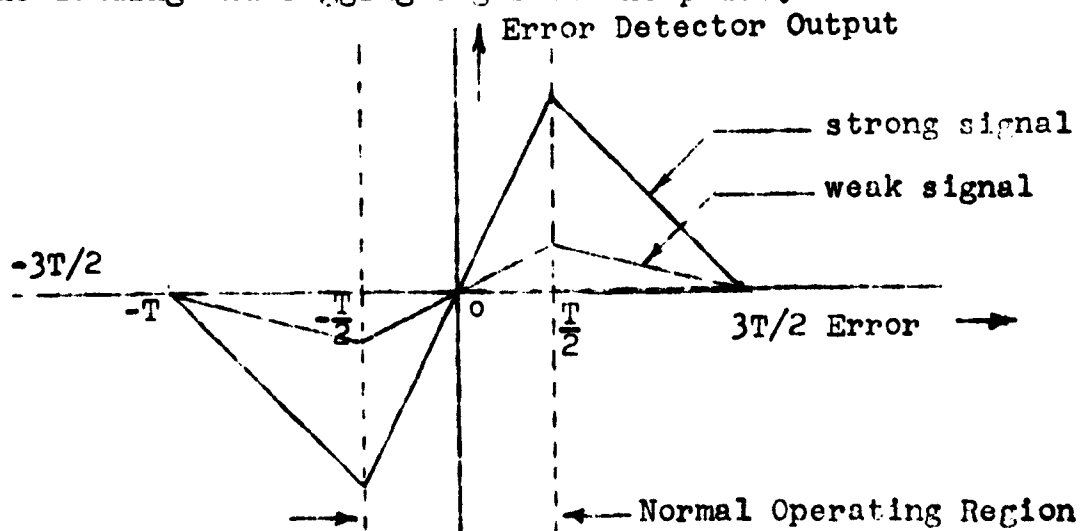

Figure 3

Error Detector Characteristic ( $T_g = T$ )

The value of K in Figure 1 is the slope of the characteristic in the normal operating region and is given by

$$(1-1) \quad K = 2 S f_p$$

where S is the signal amplitude when gated and  $f_p$  is the pulse repetition frequency.

The function unit transfer characteristic A(s) is determined by the type of response desired and is almost always either one or the other of the following:

$$a) \quad A(s) = \frac{1}{Cs} \quad (\text{an integrator})$$

$$b) \quad A(s) = \frac{1}{Cs} + \frac{1}{CDs^2} \quad (\text{a single and double integrator})$$

where C and D are constants of the system.

Upon a complete signal fade and in the absence of noise, the output of system (a) will remain constant, exhibiting position memory, while the output of system (b) will vary linearly with time. This linear variation corresponds to the velocity of the target (for a constant velocity target) and in this manner system (b) exhibits velocity memory.\*

The overall transfer function for the tracking system is

$$(1-2) \quad F(s) = \frac{KA(s)}{1 + KA(s)}$$

This leads to

$$(1-3) \quad F(s) = \frac{1}{\tau s + 1}$$

for the position memory system, and to

$$(1-4) \quad F(s) = \frac{s + \omega_n^2 \tau}{\tau s^2 + s + \omega_n^2 \tau}$$

---

\*From this point on system (a) will be referred to as the Position Memory or PM System and system (b) as the Velocity Memory or VM System.

for the velocity memory system, where  $\tau = \frac{C}{K}$  is the time constant of the position memory system and  $\omega_n = \sqrt{\frac{K}{CD}}$  is the undamped natural frequency in radians of the velocity memory system.

The steady state position error for a target of constant velocity 'v' is

$$(1-5) \quad \epsilon_{ov} = \lim_{s \rightarrow 0} \frac{v}{s} \{1 - F(s)\} = \begin{cases} v\tau & \text{for PM System} \\ 0 & \text{for VM System} \end{cases}$$

The steady state position error for a target of constant acceleration 'a' is

$$(1-6) \quad \epsilon_{oa} = \lim_{s \rightarrow 0} \frac{a}{s^2} \{1 - F(s)\} = \begin{cases} \infty & \text{for PM System} \\ \frac{a}{\omega_n^2} & \text{for VM System} \end{cases}$$

In the presence of noise the video echo appears as in Figure 4 so that the error detector output now contains in addition to the

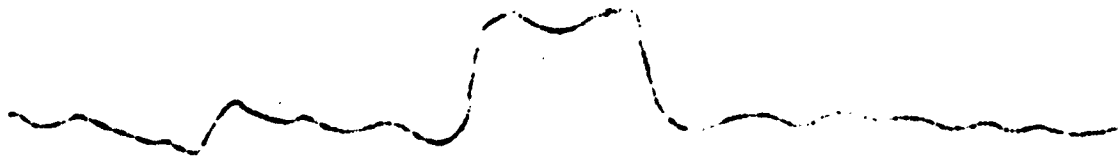

Figure 4

error signal a random component due to noise. The random component is independent from pulse to pulse since the correlation time of the video noise is of the order of the reciprocal of the receiver bandwidth which is much less than the pulse repetition period. If we assume that the mean of the gated output is due entirely to the presence of the pulsed signal and the fluctuation is due entirely to the noise so that signal and noise affect the system independently, we may write for the output of the error detector

$$(1-7) \quad i = i_s + i_N$$

where  $i_s$  is  $K(R-R')$  and  $i_N$  is the random component due to noise. We

also modify our block diagram of Figure 1 to that of Figure 5.

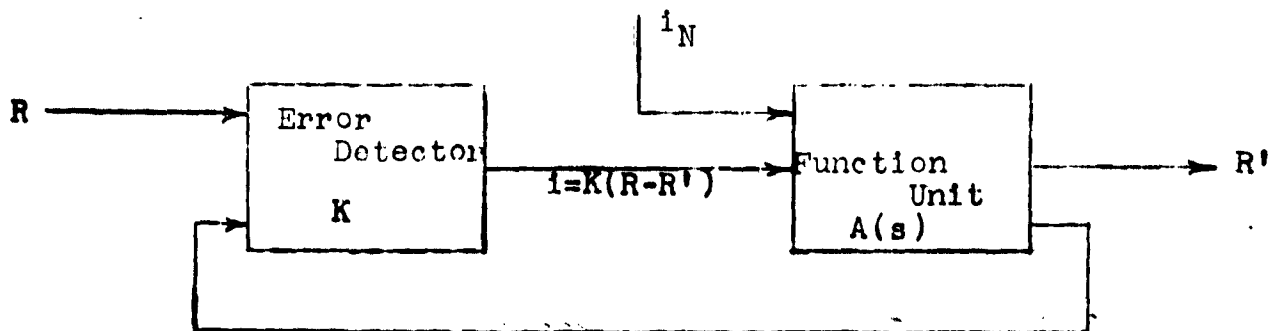

Figure 5

$i_N$  consists of a series of pulses of duration much smaller than the pulse repetition period and which have a mean value zero. The power spectrum of a pulse series of this type has been found by Uhlenbeck\* to be

$$(1-8) \quad G(f) = 2 f_r |B(f)|^2 \overline{a^2}$$

where  $f_r$  = pulse repetition frequency  
 $B(f)$  = amplitude spectrum of a single pulse of unit size  
 and  $\overline{a^2}$  = mean square value of the pulse amplitude.

The spectrum has a width of the order of the reciprocal of the pulse duration and the tracking system has a pass band of the order of one cycle so that for our purpose we shall be primarily interested in the spectrum in the region near  $f = 0$ . Now  $G(0)$  may be interpreted to be  $2 f_r \sigma_g^2$  where  $\sigma_g^2$  is the variance of the integral of the noise pulse, so that if  $i_N$  is a current,  $\sigma_g^2$  is the variance of the random charge for each gating operation. The value of  $\sigma_g^2$  for an early-late gate system and square law envelope detector can be shown to be approximately\*\*

---

\*See Section 3.4 of Reference 2.

\*\*See References 3 and 4.

$$(1-9) \quad \sigma_g^2 = T_g^2 \sigma_N^2$$

where  $\sigma_N^2$  is the dispersion of the video signal at the gate. Equation (1-9) is valid only for  $T_g$  roughly equal to the reciprocal of the receiver bandwidth. This is usually the case in practical systems.

## II. Mean Square Error.

We now turn to the calculation of the fluctuation of the output  $R'$ . If we assume that the system operates only on the linear portion of the error detector characteristic then this calculation may be performed by first finding the overall transfer characteristic  $F_N(s)$  of  $i_N$  to the output  $R$  and from this obtain the spectral density of the output. The integral of the spectral density will give us the output fluctuation. The calculations will be made for a VM system and the results for a PM system can be obtained from these by letting  $D \rightarrow \infty$  or  $\omega_n \rightarrow 0$ .

$F_N(s)$  can be computed with the aid of Figure 5, to be

$$(2-1) \quad F_N(s) = \frac{A(s)}{1 + K A(s)} = \frac{F(s)}{K} = \frac{1}{K} \frac{s + \omega_n^2 \tau}{\tau s^2 + s + \omega_n^2 \tau}$$

The spectral density of  $R'$  (excluding the  $\delta$ -function at  $f = 0$ ) is  $G(f) |F_N(j2\pi f)|^2$ , so that the dispersion of  $R'$  is given by

$$(2-2) \quad \sigma^2 = \int_0^{\infty} G(0) |F_N(j2\pi f)|^2 df = \\ = \frac{2\pi \sigma_g^2}{K^2} \int_0^{\infty} \frac{(4\pi^2 f^2 + \omega_n^2 \tau^2) df}{4\pi^2 f^2 + (\omega_n^2 \tau - 4\pi^2 f^2 \tau)^2}$$

The integral represents the equivalent noise bandwidth  $b$  of the system.

An evaluation of the integral gives

$$(2-3) \quad b = \frac{1 + \omega_n^2 \tau^2}{4\tau}$$

The term  $\frac{2f_r \sigma_g^2}{K^2}$  may be computed from (1-1) and (1-9) in terms of signal and noise amplitudes in the video giving

$$(2-4) \quad \sigma^2 = \frac{T_g^2}{2f_r} \frac{\sigma_N^2}{S^2} b$$

It should be noted, however, that  $\sigma$  is not directly proportional to the reciprocal of  $S$  since, for a given system,  $b$  is also a function of  $S$ .

We are now prepared to design a system to have minimum error for a fixed signal to noise ratio. The system parameter values which give low noise fluctuations also result in high steady state errors [see equations (1-5), (1-6) and (2-4)], therefore the total mean square error should be considered. This is given by

$$(2-5) \quad \epsilon^2 = \epsilon_0^2 + \sigma^2$$

where  $\epsilon_0$  is the steady state error.

Consider first a PM system to be designed for minimum error for a target with velocity  $v$  and a video noise to signal power ratio of  $\frac{\sigma_N^2}{S^2}$ . From (1-5), (2-3), (2-4) and (2-5), we get

$$\epsilon^2 = v^2 \tau^2 + \frac{T_g^2 \sigma_N^2}{8f_r S^2 \tau}$$

Minimizing this with respect to  $\tau$  we get for minimum  $\epsilon^2$  the condition that

$$(2-6) \quad \tau = \left[ \frac{T_g^2 \sigma_N^2}{16f_r S^2 v^2} \right]^{1/3}$$

For this value of  $\tau$  the fluctuation due to noise is twice the mean square steady state error.

The VM system has two parameters  $\omega_n$  and  $\tau$  which may be adjusted for minimum error. For a target with acceleration 'a' we get from

(1-6), (2-3), (204) and (2-5) that

$$\epsilon^2 = \frac{a^2}{\omega_n^4} \frac{T_g^2}{2f_r} \frac{\sigma_N^2}{S^2} \frac{1 + \omega_n^2 \tau^2}{4\tau}$$

and from this expression we obtain the conditions for minimum  $\epsilon$  as

(2-7)

$$\omega_n \tau = 1$$

$$\omega_n = \left[ \frac{16 a^2 f_r S^2}{T_g^2 \sigma_N^2} \right]^{1/5}$$

If  $\omega_n$  is fixed from other considerations, then for minimum  $\epsilon$  with respect to variation in  $\tau$  we still get  $\omega_n \tau = 1$ .

This represents an underdamped system [ $\omega_n \tau = 1/2$  corresponds to critical damping (see equation 1-4)]. Since these results would generally be applied to systems with low signal levels it should be noted that  $\omega_n \tau$  varies as the reciprocal of the square root of signal level and for increased signal amplitudes the damping increases.

### III. Another Criterion for System Optimization.

The analysis and system optimization of Section II in no way takes into account the fact that the system is not linear throughout the entire range of error values (see Fig. 3). The range aperture for linear operation extends about the value  $R' = R$  and is determined by the gate and echo widths. A simple technique which we may use to take cognizance of the finiteness of the range aperture is to quantize the error by associating one value with it if it falls within the range aperture and another if it is outside this aperture. This contrasts to the mean square error which weights the error values in proportion to the square of the error magnitude.

Here, as in the previous section, we shall assume complete linear

operation and our first task is to find the probability of the error falling within the range aperture. Since the noise input to the tracking system is wide band compared to the band of the tracking system, the output  $R$  and the error  $\epsilon$  will be Gaussian distributed.  $\epsilon$  has a mean value  $\epsilon_0$  given by (1-5) and (1-6) and a dispersion  $\sigma^2$  given by (2-4), so that the probability  $M$  that the error be within the range aperture is given by

$$(3-1) \quad M = \frac{1}{\sqrt{2\pi}\sigma} \int_{-L/2}^{+L/2} e^{-\frac{(\epsilon - \epsilon_0)^2}{2\sigma^2}} d\epsilon$$

where  $L$  is the magnitude of the range aperture centered at  $\epsilon = 0$ .

The value of  $L$  may be made equal to  $T$  (see Fig. 3) but in an application for which it is important to restrict the error to a specific interval,  $L$  may be made equal to this interval.

Equation (3-1) may be rewritten as

$$(3-2) \quad M = \frac{1}{\sqrt{2\pi}} \int_{\frac{-L/2 - \epsilon_0}{\sigma}}^{\frac{L/2 - \epsilon_0}{\sigma}} e^{-\frac{r^2}{2}} dr$$

where  $r$  is the normalized variable  $\frac{\epsilon - \epsilon_0}{\sigma}$ .

For low signal levels where  $\epsilon_0$  is rather close to  $L/2$  and the value of  $M$  may be maximized by maximizing the value of

$$\frac{L/2 - \epsilon_0}{\sigma}$$

This is equivalent to finding the values of  $\omega_n$  and  $\tau$  for which

$$(3-3) \quad 2 \frac{\partial}{\partial \tau} (\epsilon_0 \sigma^2) + (L/2 - 3\epsilon_0) \frac{\partial \sigma^2}{\partial \tau} = 0$$

and

$$(3-4) \quad 2 \frac{\partial}{\partial \omega_n} (\epsilon_0 \sigma^2) + (L/2 - 3\epsilon_0) \frac{\partial \sigma^2}{\partial \omega_n} = 0$$

The results for the P.M. system are obtained by substituting (1-5) (2-3) and (2-4) in (3-3) and solving for optimum  $\tau$  giving

$$(3-5) \quad \tau = \frac{L}{6v}$$

The results for the V.M. system are obtained by substituting (1-6) (2-3) and (2-4) in (3-3) and (3-4) and solving for optimum  $\omega_n$  and  $\tau$  giving

$$(3-6) \quad \omega_n \tau = 1$$

$$(3-7) \quad \omega_n = \sqrt{\frac{10a}{L}} *$$

Condition (3-7) is valid regardless of any constraints on the value of  $\omega_n \tau$  but the optimum value of  $\omega_n \tau$  is given by (3-6).

#### IV. Probability of Target Loss.

The analyses of Sections II and III consider steady state or stationary solutions for the output of the tracking system. In reality a steady state is never reached if one takes into account the true nature of the error detector characteristic. For any system with noise the error will at times reach a sufficiently large value to give zero output from the error detector. When this occurs

---

\*The result given by this equation was found by Muchmore et al (see reference 5) for a critically damped system using a different criterion for optimization.

the existence of a target echo does not act as a restoring "force" and the system output is governed by noise only. The noise may act to reduce the error and to bring the system under control of the target echo again but it may, also, act to increase the error. Ultimately the output will leave the aperture not to return.

An important question that may be asked is, "What is the probability that the target is not lost in time  $t$ ?" By "lost" we mean that the error does not exceed a certain limit for the whole period. The limit may be the limit of linear operations or may be a value determined from other considerations for a particular application.

This problem is a formidable one and a solution seems possible only in the case of a P.M. system with complete linear operation within the limits imposed on the error.

The method of solution is as follows:

1. Set up the Fokker-Planck<sup>\*\*</sup> equation for the probability density of the output  $R'$ . This partial differential equation is derived from the system transfer function.
2. Solve the equation with the boundary conditions which specify the output at the start of the track and the fact that the system is "absorbed" if the error exceeds the imposed limits.
3. Integrate the solution for the probability density in the restricted interval to obtain the probability of the system not having left this interval.

The differential equation which describes the P.M. system may be obtained from Figure 5 as

---

<sup>\*\*</sup>A complete discussion of the method of Fokker-Planck and of Brownian Motion problems may be found in references 6 and 7.

$$\tau \frac{dR'}{dt} + R' = R + \frac{i_N}{K}$$

The solution for  $R'$  may be considered in two parts--the first as the response to the forcing function  $R$  and the second as the response to the noise  $i_N$ . Let the first be  $R'$  and the second  $x$ . Thus for  $x$  we have the differential equation

$$(4-1) \quad \frac{dx}{dt} + \frac{x}{\tau} = \frac{i_N}{K\tau}$$

This equation is analogous to the Langevin equation of Brownian Motion.

The derivation of the Fokker-Planck equation from (4-1) will not be given here but may be found in the articles of Chandrasekhar<sup>6</sup> and Wang and Uhlenbeck<sup>7</sup>. The Fokker-Planck equation for the probability density is

$$(4-2) \quad \frac{\partial p}{\partial t} = \frac{1}{\tau} \frac{\partial}{\partial x} (xp) + \frac{\sigma^2}{\tau} \frac{\partial^2 p}{\partial x^2}$$

where  $\sigma^2$  is the dispersion of  $R'$  (and, also  $x$ ) found in Section II for a completely linear error detector characteristic. The term  $\frac{\sigma^2}{\tau}$  corresponds to one quarter of the spectral density of  $\frac{i_N}{K\tau}$  which is the appropriate coefficient for the second derivative term in (4-2) according to the method of Fokker-Planck.

The first thing we can do is to check our results for the case handled in Section II. This case corresponds to imposing the following boundary conditions on (4-2):

$$(4-3) \quad \begin{aligned} p(\pm \infty, t) &= 0 \\ p(x, 0) &= \delta(x - x_0) \end{aligned}$$

The solution with these boundary conditions is found in Appendix A and is given by

$$(4-4) \quad p(x, t) = [2\pi\sigma^2(1-e^{-2t/\tau})]^{-1/2} \exp\left\{-\frac{(x-x_0e^{-t/\tau})^2}{2\sigma^2(1-e^{-2t/\tau})}\right\}$$

This corresponds to a Gaussian distribution for  $x$  with a time varying mean given by  $x_0 e^{-t/\tau}$  and a time varying dispersion given by  $\sigma^2(1 - e^{-2t/\tau})$ . The steady state values are  $\epsilon_0$  and  $\sigma^2$  respectively which agree with results in Section II.

It is interesting to note what happens to  $p(x,t)$  for the limiting case of zero noise. A Gaussian probability density with its dispersion approaching zero is in the limiting case a delta function so that

$$\lim_{\sigma^2 \rightarrow 0} p(x,t) = \delta(x - x_0 e^{-t/\tau})$$

This tells us in effect that if the noise should suddenly cease at  $t = 0$  and at that time  $x = x_0$ , thereafter  $x$  will have a value  $x_0 e^{-t/\tau}$  with certainty. This is in exact agreement with our knowledge of the normal transient response for the system.

We now turn to the problem of the solution for the probability of not losing the target in the sense discussed at the beginning of this section. We shall do this for a zero velocity target so that  $\epsilon_0 = 0$  and  $\dot{x} = \epsilon$ . For this we must find a method of eliminating from our probability calculations the possibility that  $\epsilon = R - R'$  be outside the range aperture at any time in the tracking interval. We shall consider a target lost if at any time in the observation time interval, the noise is sufficient to cause a deviation of the error  $\epsilon'$  such that  $|\epsilon'| \geq L/2$ .

To calculate the probability of losing a target, we may employ an artifice in the problem. Let us consider the case where two "absorbing" walls are placed at either end of the range aperture (see Figure 6). These walls have the characteristic that if  $R'$  should have a value equal to  $R = L/2$  the system would be absorbed and not released. Therefore, with the absorbing walls, if, after some time,  $\epsilon$  is found within the range aperture, then it necessarily remained within the range aperture the entire interval; otherwise, it would

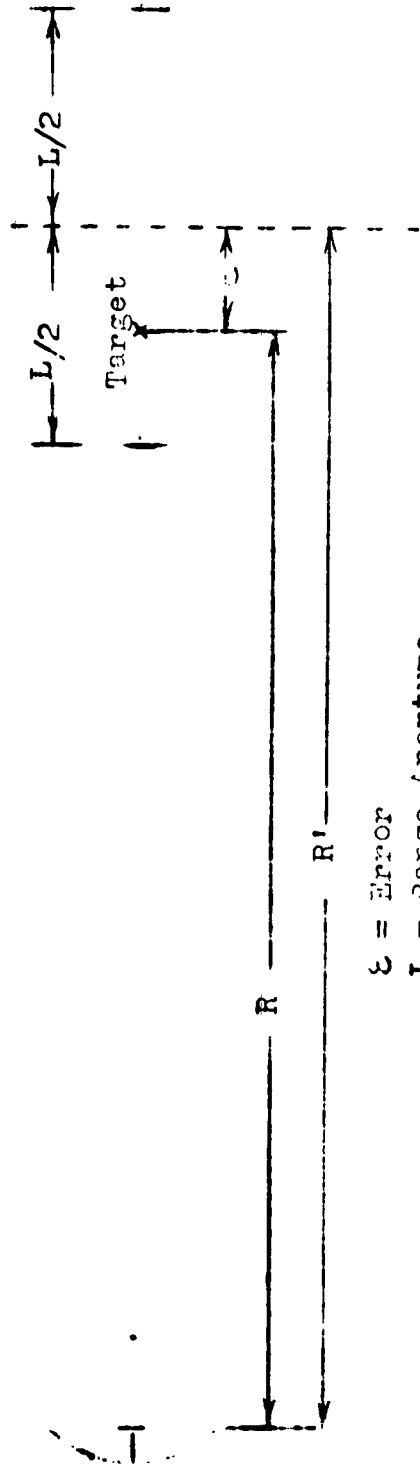

$\epsilon$  = Error

$L$  = Range Aperture

Figure 6

have been absorbed and "out of circulation". The existence of the walls has no effect on the fluctuations of  $R'$  as long as  $\epsilon$  remains within the aperture. The probability of not losing the target in our problem is, therefore, the same as that of  $R$  not being absorbed by one of the walls. The effect of the absorbing walls is to introduce the boundary conditions that for  $x_0 = 0$ , the probability density  $p(x, t) = 0$  for  $x = \pm L/2$ . Mathematically, the problem remains to solve (4-2) with the boundary conditions that

$$\begin{aligned} p\left(\pm \frac{L}{2}, t\right) &= 0 \\ p(x, 0) &= \delta(x) \end{aligned}$$

The solution for low signal levels is given in Appendix B and the result is that the probability of not losing the target is

$$(4-5) \quad P = \sum_{n=1,3,5}^{\infty} \frac{4}{n\pi} e^{-n^2\theta + \frac{\psi^2\theta}{\pi^2}} \Omega_n(\psi)$$

where  $\psi$  and  $\theta$  are dimensionless parameters given by

$$\theta = \pi^2 \frac{\sigma^2}{L^2} \frac{t}{\tau} \quad \text{and} \quad \psi = \frac{L}{2\sigma}$$

and  $\Omega_n(\psi)$  is defined by

$$\Omega_n(\psi) = \int_0^{\frac{n\pi}{2}} e^{-\frac{\psi^2 x^2}{n^2 \pi^2}} \cos x \, dx$$

The function  $P(\psi, \theta)$  is tabulated as a function of  $\theta$  for several different values of  $\psi$  in Appendix D and is graphed in Figure 7.

For higher signal levels a different method of solving (4-2) is necessary. This is done in Appendix C. The results are tabulated in Appendix D and graphed in Figure 8.

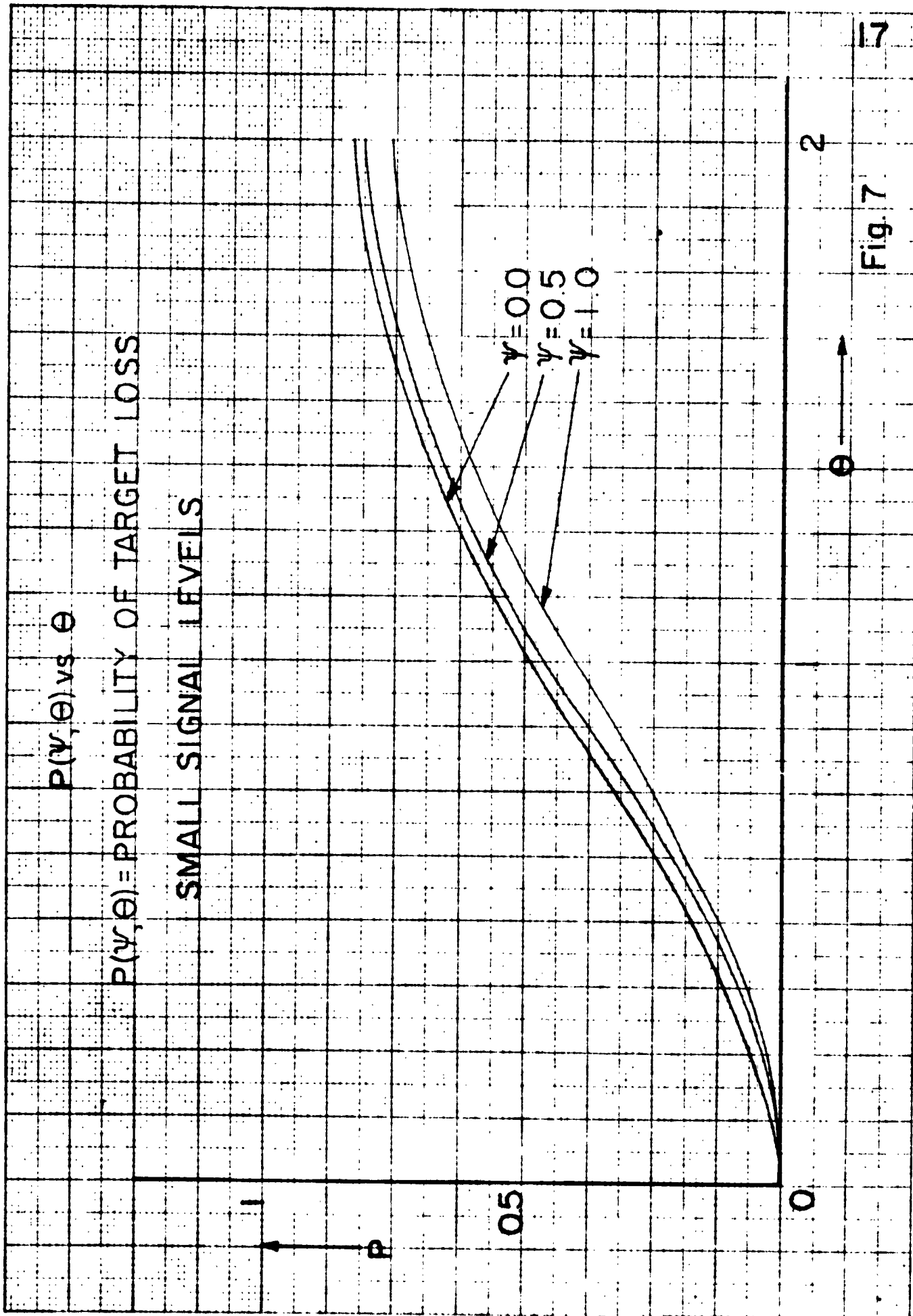

Fig. 7

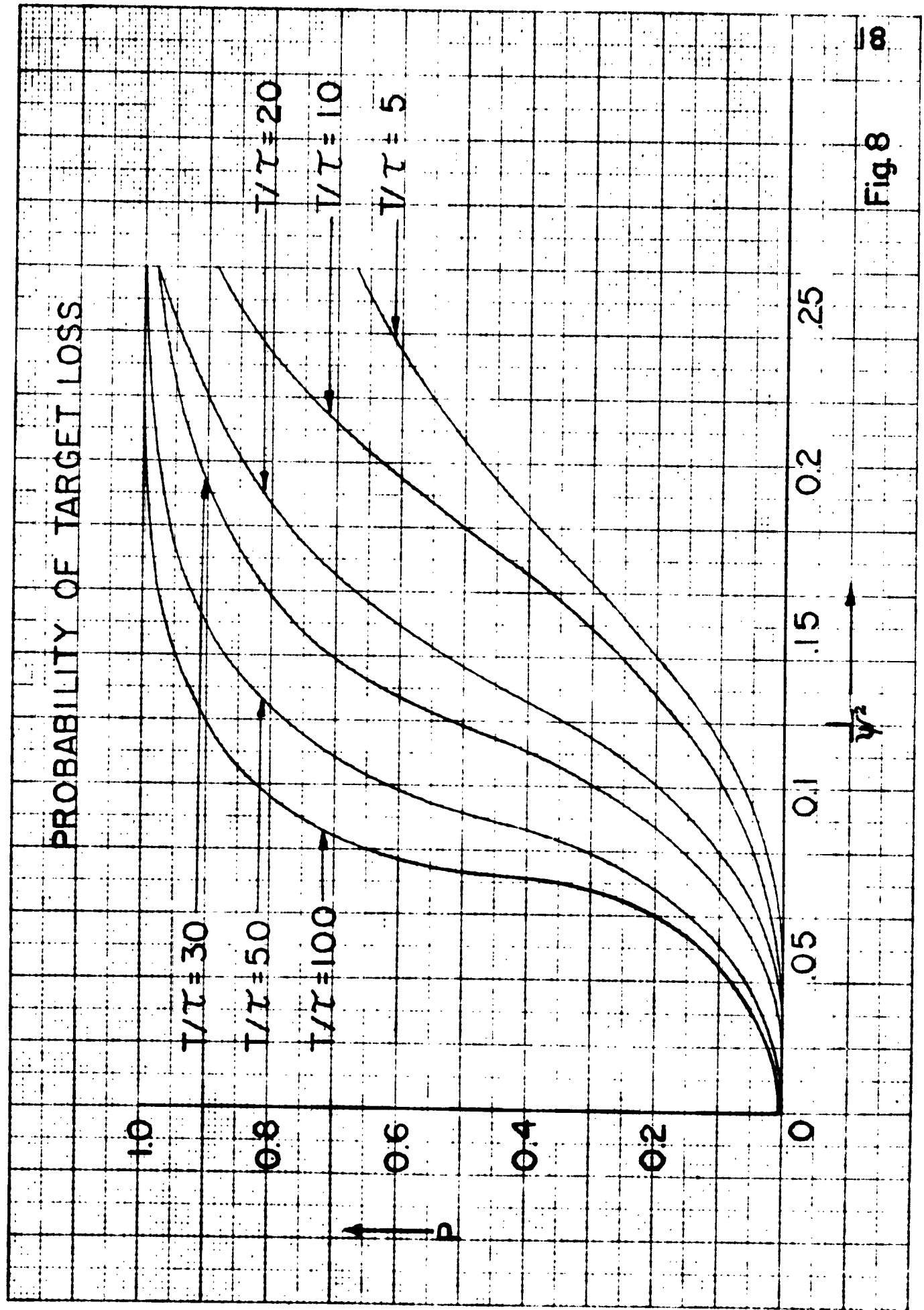

Fig. 8

Appendix A Solution of the Fokker-Planck Equation in an Infinite Interval.

The boundary conditions are that  $p(\pm\infty, t) = 0$  and that at  $t = 0, x = x_0$  with certainty. This is equivalent to  $p(x, 0) = \delta(x - x_0)$ . The solution may be found as follows:

Change variables of (4-2) to

$$z = x e^{t/\tau}$$

$$t' = t$$

Since

$$\frac{\partial p}{\partial t} = \frac{\partial p}{\partial t'} + \frac{x}{\tau} e^{t/\tau} \frac{\partial p}{\partial z}$$

and

$$\frac{\partial^2 p}{\partial x^2} = e^{2t/\tau} \frac{\partial^2 p}{\partial z^2}$$

the original equation, after dropping the prime from  $t$  becomes

$$\frac{\partial p}{\partial t} = \frac{1}{\tau} p + \frac{\sigma^2}{\tau} e^{2t/\tau} \frac{\partial^2 p}{\partial z^2}$$

with the initial condition that at  $t = 0$

$$p = \delta(z - x_0)$$

Now, if we let

$$p = e^{t/\tau} f(z, t)$$

we obtain for  $f(z, t)$  the equation,

$$\frac{\partial f}{\partial t} = \frac{\sigma^2}{\tau} e^{2t/\tau} \frac{\partial^2 f}{\partial z^2}; f(z, 0) = \delta(z - x_0)$$

We may now separate variables by letting  $f(z, t) = S(z) T(t)$

with the result that

$$\frac{T'}{T} - \frac{\tau}{\sigma^2} e^{-2t/\tau} = \frac{S''}{S} = -\lambda^2, \text{ a constant}$$

From this we get

$$T = (\text{constant}) \exp \left\{ -\lambda^2 \int_0^t \frac{\sigma^2}{\tau} e^{2t/\tau} dt \right\} = (\text{constant}) \exp \left\{ -\frac{\lambda^2 \sigma^2}{2} (e^{2t/\tau} - 1) \right\}$$

and

$$S = \text{constant } e^{j\lambda z}$$

Since the constants in the solution for S and T depend on  $\lambda$  and all values of  $\lambda$  are permitted, we may write

$$f(z,t) = \int_{-\infty}^{+\infty} A(\lambda) \exp \left\{ j\lambda z - \lambda^2 \frac{\sigma^2}{2} (e^{2t/\tau} - 1) \right\} d\lambda$$

From the condition that  $f(z,0) = \delta(z-x_0)$  we have

$$\int_{-\infty}^{+\infty} A(\lambda) e^{j\lambda z} d\lambda = \delta(z-x_0)$$

or

$$A(\lambda) = \frac{e^{-j\lambda x_0}}{2\pi}$$

This value for  $A(\lambda)$  may be substituted in the expression for  $f(z,t)$  and after integration the result is

$$f(z,t) = [2\pi\sigma^2 (e^{2t/\tau} - 1)]^{-1/2} \exp \left\{ -\frac{(z-x_0)^2}{2\sigma^2 (e^{2t/\tau} - 1)} \right\}$$

Making the necessary substitutions, we obtain for  $p$  as a function of  $x$  and  $t$  the expression

$$p(x,t) = [2\pi\sigma^2 (1 - e^{-2t/\tau})]^{-1/2} \exp \left\{ -\frac{(x-x_0 e^{-2t/\tau})^2}{2\sigma^2 (1 - e^{-2t/\tau})} \right\}$$

**Appendix B - Solution of Fokker-Planck Equation in a Finite Interval and Low Signal Levels.**

The boundary conditions on (4-2) are given by

$$p(\pm L, t) = 0$$

$$p(x, 0) = \delta(x)$$

The coefficient  $\frac{1}{\tau}$  depends only on signal strength and not at all on noise, while  $\frac{\sigma^2}{\tau}$  depends only on the noise level and not on signal. For zero signal  $\frac{1}{\tau}$  vanishes and (4-6) with its boundary conditions reduces to a standard problem in linear heat conduction. (c.g. see Churchill<sup>8</sup>, p. 102)

We may separate variables by writing  $p(x, t)$  in the form

$$(B-1) \quad p(x, t) = v(x) \cdot u(t)$$

so that for  $v(x)$  and  $u(t)$  we obtain

$$\frac{\tau}{\sigma^2} \frac{u'}{u} = \frac{1}{\sigma^2} \frac{(xv)'}{v} + \frac{v''}{v} = -\lambda, \quad \text{a constant.}$$

From this we get

$$(B-2) \quad u = \text{constant } e^{-\lambda \sigma^2 \frac{t}{\tau}}$$

and for  $v(x)$

$$(B-3)$$

$$v'' + \frac{xv'}{\sigma^2} + \left(\frac{1}{\sigma^2} + \lambda\right) v = 0$$

The boundary conditions on (4-2) imply that  $v(\pm \frac{L}{2}) = 0$

For low signal levels  $\frac{1}{\sigma^2}$  is small and we may solve (B-2) to a first order in  $\frac{1}{\sigma^2}$ . But to do this, it is necessary to put (B-3) in a form from which it is possible to eliminate second order terms.

This may be done by using a new dependent variable  $f(x)$  such that

$$(B-4) \quad v(x) = e^{-\frac{x^2}{4\sigma^2}} f(x)$$

so that

$$v''(x) = e^{-\frac{x^2}{4\sigma^2}} \left( f'' - \frac{x}{\sigma^2} f' - \frac{f}{2\sigma^2} + \frac{x^2}{4\sigma^4} f \right)$$

Now (B-3) in terms of  $f(x)$  becomes

$$(B-5) \quad f'' + \left( \frac{1}{2\sigma^2} - \frac{x^2}{4\sigma^4} + \lambda \right) f = 0$$

with the boundary condition

$$f(\pm L/2) = 0$$

Let us, for the time being, ignore the  $\frac{x^2 f}{4\sigma^4}$  term and we shall examine later under what conditions this is warranted. Equation

(B-5) now remains as

$$(B-6) \quad f'' + \left( \frac{1}{2\sigma^2} + \lambda \right) f = 0 ; \quad f(\pm \frac{L}{2}) = 0$$

The solution is

$$(B-7) \quad f = A \cos x \sqrt{\frac{1}{2\sigma^2} + \lambda} + B \sin x \sqrt{\frac{1}{2\sigma^2} + \lambda}$$

where A and B are constants. The condition  $f(\pm \frac{L}{2}) = 0$

requires that  $B = 0$  and that

$$(B-8) \quad \sqrt{\frac{1}{2\sigma^2} + \lambda} = \frac{n\pi}{L} ; \quad n = 1, 3, 5, \dots$$

Therefore,  $\lambda$  may only assume the values

$$(B-9) \quad \lambda_n = \frac{n^2 \pi^2}{L^2} - \frac{1}{2\sigma^2} ; \quad n = 1, 3, 5, \dots$$

These represent the eigenvalues of  $\lambda$  for equation (4-2) with its associated boundary conditions.

The complete solution may be found by combining (B-4), (B-7),

(B-8) with (4-2) to obtain

$$(B-10) \quad p(x,t) = \sum_{n=1,3,5,\dots}^{\infty} A_n \exp \left\{ - \frac{x^2}{4\sigma^2} - \frac{n^2 \pi^2 \sigma^2}{L^2} \left( \frac{t}{\tau} + \frac{t}{2\tau} \right) \right\} \cos \frac{n\pi x}{L}$$

It may be noted that the lowest eigenvalue  $\lambda_1$  is equal to

$\frac{\pi^2}{L^2} - \frac{1}{2\sigma^2}$  and the highest value of  $x$  in (B-5) occurs at the boundary

$x = L/2$ . Therefore, in (B-5),  $\frac{x^2}{4\sigma^4} \leq \frac{L^2}{16\sigma^4}$  and  $\frac{1}{2\sigma^2} + \lambda \geq \frac{\pi^2}{L^2}$

so that neglecting the former term does not introduce much error

$$\text{if } \frac{L^2}{4\sigma^2} \ll \pi$$

The constant  $A_n$  can be determined from the initial condition that  $p(x,0) = \delta(x)$  or

$$(B-11) \quad \sum_{n=1,3,5}^{\infty} A_n e^{-\frac{x^2}{4\sigma^2}} \cos \frac{n\pi x}{L} = \delta(x)$$

Multiplying both sides by  $e^{-\frac{x^2}{4\sigma^2}} \cos \frac{m\pi x}{L}$  ( $m = \text{odd}$ )

integrating from  $-L/2$  to  $L/2$ , and recognizing that

$$\int_{-L/2}^{L/2} \cos \frac{m\pi x}{L} \cos \frac{n\pi x}{L} dx = \begin{cases} L/2 & n = m \\ 0 & n \neq m \end{cases}$$

we have

$$A_n = \frac{2}{L}$$

To find the probability,  $P$ , of not losing the target we must integrate the probability density  $p(x,t)$  in the range aperture.

$$(B-12) \quad P = \int_{-L/2}^{L/2} p(x,t) dx = \sum_{n=1,3,5..}^{\infty} \frac{2}{L} \exp \left\{ -\frac{n^2 \pi^2 \sigma^2 t}{L^2} + \frac{t}{2\tau} \right\} \cdot \int_{-L/2}^{L/2} e^{-\frac{x^2}{4\sigma^2}} \cos \frac{n\pi x}{L} dx$$

We define the dimensionless quantities

$$\theta = \pi^2 \frac{\sigma^2}{L^2} t \quad \text{and}$$

$$(B-13) \quad \psi = \frac{L}{2\sigma}$$

which, when substituted in (B-12) gives

$$(B-14) \quad P(\psi, \theta) = \sum_{n=1,3,5}^{\infty} \frac{4}{n\pi} e^{-n^2\theta + \frac{\psi^2\theta}{\pi^2}} \Omega_n(\psi)^*$$

\*The function  $P(0, \frac{\theta}{\pi^2})$  has been tabulated by Olson and Schultz in Reference 9.

where the function  $\Omega_n(\psi)$  is defined by

$$(B-15) \quad \Omega_n(\psi) = \int_0^{\frac{n\pi}{2}} e^{-\frac{\psi^2 x^2}{n^2 \pi^2}} \cos x \, dx$$

The function  $\Omega_n(\psi)$  is briefly discussed and tabulated in Appendix D.

Appendix C - Solution of Fokker-Planck Equation in a Finite Interval with Higher Signal Levels.

Here, as in Appendix B, the boundary conditions on (4-2) are given by

$$p(\pm L/2, t) = 0$$

$$p(x, 0) = \delta(x)$$

and as before we start by separating variables and obtaining equations (B-2) and (B-5). In equation (B-5), substitute

$$(C-1) \quad y = \frac{x}{\sigma}$$

In terms of the new variable  $y$ , we obtain

$$(C-2) \quad \frac{d^2 f}{dy^2} + \left( \frac{1}{2} - \frac{y^2}{4} + \lambda' \right) f = 0$$

where

$$\lambda' = \sigma^2 \lambda$$

with the boundary conditions that at  $y = \pm \frac{L}{2\sigma} = \pm \psi$ ,  $f = 0$

Equation (C-2) is the Weber equation and can be found discussed in the literature. (e.g. see Ince<sup>10</sup>, Weber<sup>11</sup>, Whittaker and Watson<sup>12</sup>.) The solution to this equation for integral values of  $\lambda'$  is the parabolic cylinder function which may be expressed in closed form as

$$(C-3) \quad f_{\lambda'} = \left[ \lambda' : 2\sqrt{2\pi} \right]^{-1/2} e^{-y^2/4} H_{\lambda'}(y)$$

where  $H_{\lambda'}(y)$  is the Hermite polynomial of degree  $\lambda'$ .\*

For non-integral values of  $\lambda'$  we may solve equation (C-2) but not in closed form by first defining a new dependent variable by

$$(C-4) \quad f = e^{-y^2/4} w(y)$$

thereby transforming equation (C-2) to

$$(C-5) \quad \frac{d^2 w}{dy^2} - y \frac{dw}{dy} + \lambda' w = 0$$

We may now assume a series solution for  $w$ ,

$$(C-6) \quad w = 1 + h_1 y + h_2 y^2 + h_3 y^3 + \dots$$

Substituting this in (C-5), we find that the coefficient of  $y^n$  is  $(n+2)(n+1)h_{n+2} - nh_n + \lambda'h_n$ . Setting all the coefficients equal to zero, we obtain a recurrence formula

$$(C-7) \quad h_{n+2} = \frac{-\lambda' + n}{(n+1)(n+2)}$$

This leads to two solutions for  $w$ --one, a power series containing all terms even powered in  $y$ , and one with all odd powered terms in  $y$ , giving an even function and odd function solution respectively.

Since our result is necessarily symmetrical about the zero axis, we are left with the solution

$$(C-8) \quad w = 1 - \frac{\lambda'}{2} y^2 + \frac{\lambda'(\lambda' - 2)}{4!} y^4 - \frac{\lambda'(\lambda' - 2)(\lambda' - 4)}{6!} y^6$$

It now remains to find the values of  $\lambda'$  for which  $w$  vanishes at the boundaries  $y = \pm \psi$ . A method applicable here was used by Chandrasekhar<sup>14</sup> in a problem in Stellar Dynamics. He attributes this method to Sommerfeld<sup>15</sup>.

\*The functions of the parabolic cylinder may be found plotted in Jahnke and Emde<sup>13</sup>, p.33.

If we examine (C-2) with reference to our discussion of the parent equation (B-5), we may note that the solution for (C-2) for small  $\psi$  can be accomplished by neglecting the term  $\frac{y^2 f(y)}{4}$ . This leads to a series of eigenvalues for  $\lambda'$ , the lowest of which is

$$(C-9) \quad \lambda'_1 = \frac{\pi^2}{4\psi^2} - \frac{1}{2}$$

This lowest eigenvalue decreases with increasing  $\psi$ . For  $\psi$ , we cannot use the value in (C-9) but may obtain the eigenvalues with same reasoning used often in Quantum Mechanics to find eigenvalues. (e.g., see the discussion of the harmonic oscillator in Pauling and Wilson<sup>17</sup>, p. 71). The reasoning is as follows: The solution  $f(y)$  in equation (C-2) is  $e^{-\frac{1}{4}y^2} w(y)$  where  $w(y)$  is given by the power series (C-8). This result will not converge for  $y \rightarrow \infty$  in spite of the  $e^{-\frac{1}{4}y^2}$  factor, unless the series (C-8) terminates after a finite number of terms. This may be demonstrated by comparing the series for  $w(y)$  to the series for  $e^{y^2/2}$ .

$$(C-10) \quad e^{y^2/2} = 1 + \frac{y^2}{2} + \frac{y^4}{2^2 \cdot 2!} + \dots + \frac{y^n}{2^{n/2} \frac{n}{2}!} + \frac{y^{2n+2}}{2^{n/2+1} (\frac{n}{2} + 1)!} + \dots$$

The ratio of the  $(n+2)$ <sup>nd</sup> term coefficient to the  $n$ <sup>th</sup> term coefficient for large  $n$  is  $\frac{1}{n}$ .

The recursion formula (C-7) also gives as the ratio  $\frac{h_{n+2}}{h_n}$  for large  $n$  the value  $\frac{1}{n}$ . Therefore, coefficients for the higher degree terms of  $y$  in (C-8) and (C-10) differ only by a constant ratio, so that  $w(y)$  is of the order of  $e^{y^2/2}$  for large  $y$ . Since  $f(y) = e^{-y^2/4} w(y)$ ,  $f(y)$  will diverge for  $y \rightarrow \infty$ .

For convergence, (C-8) must terminate after a finite number of terms, or  $\lambda'$  must take on the values 0, 2, 4, ..... These represent the eigenvalues of  $\lambda'$  for  $\psi \rightarrow \infty$ , the lowest eigenvalue being zero.

It would seem therefore, that the lowest eigenvalue takes on the values given in (C-9) for low values of  $\psi$  and approaches 0 as  $\psi \rightarrow \infty$  as shown in the sketch on page 28. The second lowest eigenvalue by the same token will behave similarly and approach 2 as an asymptotic value.

With this in mind, let us rearrange the terms of (C-8) so that our solution is in terms of a power series in  $\lambda'$ . We have then

$$(C-11) \quad w(y) = 1 - \lambda' \varphi_1(y) + \lambda'^2 \varphi_2(y) - \lambda'^2 \varphi_2(y) - \lambda'^3 \varphi_3(y) \dots$$

The functions  $\varphi_1(y), \varphi_2(y) \dots$  are power series in  $y$ :

$$(C-12) \quad \begin{aligned} \varphi_1(y) &= a_2 y^2 + a_4 y^4 + a_6 y^6 + \dots \\ \varphi_2(y) &= b_4 y^4 + b_6 y^6 + \dots \end{aligned} \quad \text{etc.}$$

Since  $w = 0$  at  $y = \psi$  we may substitute this condition in (C-11) and solve for  $w(y)$  by first considering only the first two terms in the series and neglecting the higher order terms in  $\lambda'$ , obtaining for the lowest eigenvalue

$$(C-13) \quad \lambda_1' = \frac{1}{\varphi_1(\psi)}$$

Greater accuracy may be obtained by including another term in the series (C-11) and obtaining

$$(C-14) \quad \lambda_1' = \frac{\varphi_1(\psi) \pm [\varphi_1^2(\psi) - 4\varphi_2(\psi)]^{1/2}}{2\varphi_2(\psi)}$$

For values of  $\psi$  greater than 2, (C-14) and even (C-13) offer very good accuracy. The results of these calculations are tabulated in Appendix D. For  $\psi$  small, the method breaks down because it would be necessary to work with many terms of equation (C-11). This presents difficulties in the computation of the terms and then in the solution of a high degree polynomial in  $\lambda'$ . It is interesting to note

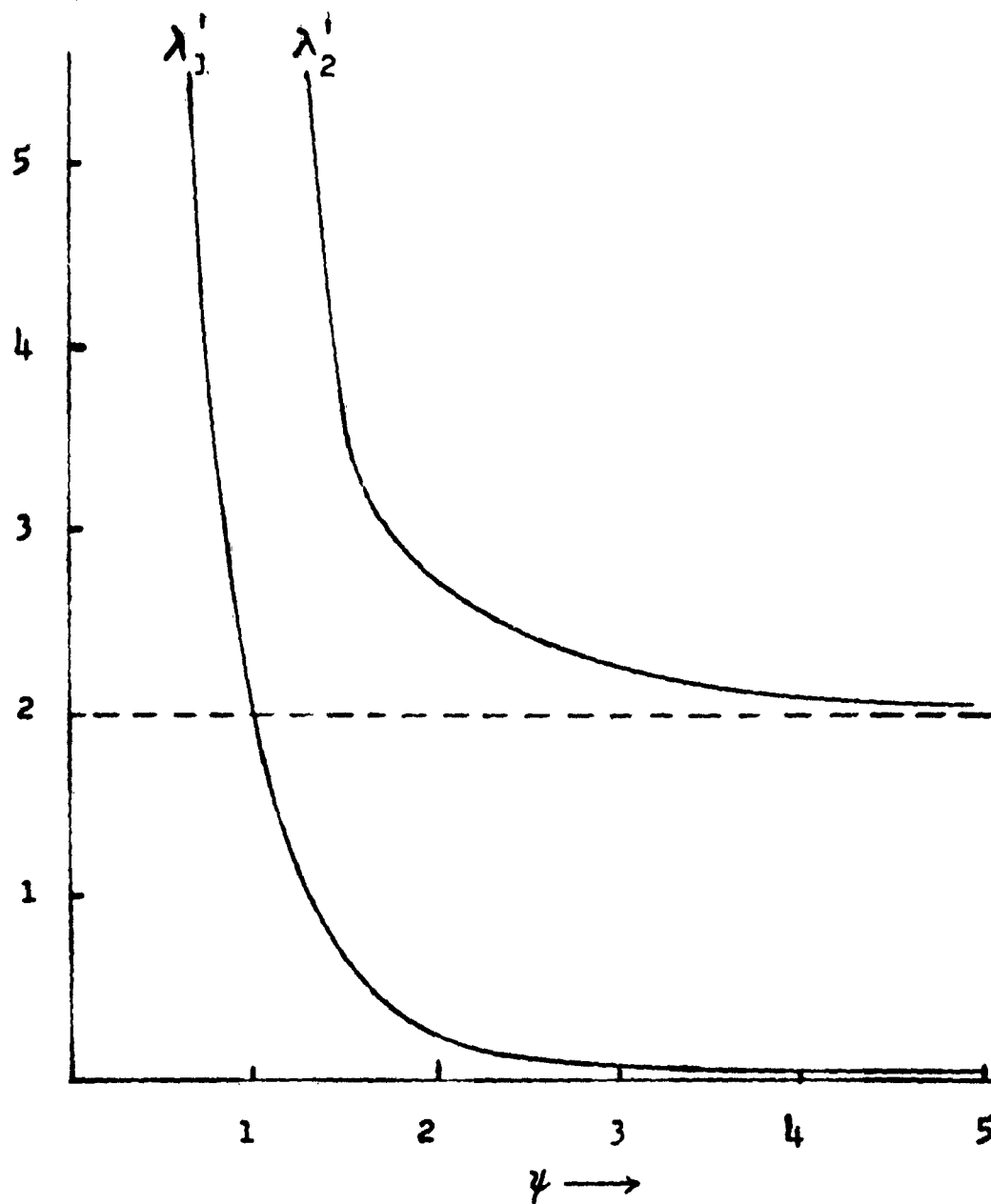

The first two eigenvalues of equation (C-2) as a function of  $\psi$ .

that for  $\psi = 1$ , the lowest eigenvalue  $\lambda'$ , by the method outlined above gives

$$\lambda_1' = 2.034 \text{ using equation (C-14), and}$$

$$\lambda_1' = 1.999 \text{ by including the } \lambda'^3 \text{ term in (C-11) and solving}$$

the resulting cubic equation in  $\lambda_1'$ ,

$$\text{while by the method of Appendix B, we obtain } \lambda_1' = \frac{\pi^2}{4} - \frac{1}{2} = 1.967$$

This excellent agreement indicates an overlapping in range of applicability of the two methods of solution, thus making unnecessary any higher order approximation, such as Perturbation or W.K.B. methods, to extend the range of the method of solution used for low  $\psi$  in Appendix B.

To each eigenvalue  $\lambda_n'$  corresponds an eigenfunction  $W_n(y)$ , which is a solution to (C-5) and an eigen function  $f_n(y) = e^{-y^2/4} W_n(y)$ , which is a solution to (C-2). The homogeneous differential equation (C-2) is in standard Sturm-Liouville form with homogeneous boundary conditions so that the functions  $f_n(y)$  form an orthogonal set.\*

$$\text{Or, (C-15) } \int_{-\psi}^{+\psi} f_n(y) f_m(y) dy = \int_{-\psi}^{+\psi} e^{-y^2/2} W_n(y) W_m(y) dy = 0 \quad n \neq m$$

The solution to the original partial differential equation may now be formed by combining (B-2), (B-4), (C-1) and (C-4) into (B-1).

The solution is

$$\text{(C-16) } p(x,t) = \sum_n A_n e^{-\lambda_n' t/\tau} e^{-\frac{x^2}{2\sigma^2}} W_n\left(\frac{x}{\sigma}\right)$$

The constant  $A_n$  may be determined from the initial condition

$$p(x,0) = \delta(x) \quad \text{or}$$

$$\text{(C-17) } \sum_n A_n e^{-\frac{x^2}{2\sigma^2}} W_n\left(\frac{x}{\sigma}\right) = \delta(x)$$

\*The proof of this statement, as well as a discussion on Sturm-Liouville problems may be found in Churchill<sup>8</sup>, Ince<sup>10</sup>, Margenau and Murphy<sup>16</sup>, etc.

In terms of  $y = \frac{x}{\sigma}$ , this is

$$(C-18) \quad \sum A_n e^{-y^2/2} W_n(y) = \frac{1}{\sigma} \delta(y)$$

Since  $f_n(y) = e^{-y^2/4} W_n(y)$  form an orthogonal set, if we multiply both sides of (C-18) by  $W_m(y)$  and integrate over the interval  $y = -\psi$  to  $y = +\psi$ , all the terms in the summation will vanish except that for  $n = m$ . In other words,

$$\sum_n A_n \int_{-\psi}^{+\psi} e^{-y^2/2} W_n(y) W_m(y) dy = \int_{-\psi}^{+\psi} \frac{1}{\sigma} \delta(y) W_m(y) dy$$

leads to

$$(C-19) \quad A_m = \frac{1}{2\sigma \int_0^{\psi} e^{-y^2/2} W_m^2(y) dy}$$

We can find the probability of not losing the target from (C-16) and (C-19) by

$$(C-20) \quad P = \int_{-L/2}^{L/2} p(x,t) dx$$

Or in terms of the variable  $y$

$$(C-21) \quad P = \sum_n \int_{-\psi}^{+\psi} A_n e^{-\lambda_n' \frac{t}{\tau}} e^{-y^2/2} W_n(y) \sigma dy$$

Substituting the value of  $A_n$  leads to

$$(C-22) \quad P = \sum_n e^{-\lambda_n' \frac{t}{\tau}} \frac{\int_0^{\psi} e^{-y^2/2} W_n(y) dy}{\int_0^{\psi} e^{-y^2/2} W_n^2(y) dy}$$

Since the first eigenvalue  $\lambda_1'$  is near zero and the second in the order of two, etc., we see that all terms except the first in equation (C-22) will diminish rapidly to zero with increasing  $t/\tau$ .

Ample accuracy is obtained if we use only the first term of the series, or

$$(C-23) \quad P \approx e^{-\lambda_1' t/\tau} \frac{\int_0^\psi e^{-y^2/2} w_1(y) dy}{\int_0^\psi e^{-y^2/2} w_1^2(y) dy} = C_1(\psi) e^{-\lambda_1' \frac{4\theta\psi^2}{\pi^2}}$$

A tabulation of the coefficient,  $C_1(\psi)$ , as a function of  $\psi$  may be found in Appendix D.

It may seem surprising that the coefficient has a value very slightly greater than one, which would seem to indicate that for  $\theta \rightarrow 0$ ;  $P > 1$ , a situation which is impossible. The difficulty lies in the fact that only the first term in equation (C-22) was used. The second eigen function would give a negative contribution. At any rate, this introduces an error only for  $t/\tau$  small as discussed above.

#### Appendix D

##### 1. Evaluation of $\Omega_n(\psi)$

The function

$$\Omega_n(\psi) = \int_0^{\frac{n\pi}{2}} e^{-\frac{\psi^2 x^2}{n^2 \pi^2}} \cos x \, dx \quad n = 1, 3, 5, \dots$$

may be found in terms of Error Integrals with complex arguments.

Complete tables for this are not available and therefore the function had to be evaluated. Since our interest is primarily in low values of  $\psi$  it was found advisable to expand the exponential function as a power series in  $\psi$  and evaluate term by term, each term being of the form  $\int_0^{n\pi/2} x^n \cos x \, dx$  ( $n$  odd). This integral is tabulated for  $n$  even in reference 18, but for  $n$  odd a brief tabulation sufficient for our purposes is shown below.

$\psi$	$n = 1$	$n = 3$	$n = 5$
0.1	.9995	-.9977	.9976
0.2	.9981	-.9909	.9904
0.5	.9983	-.9441	.9411
1.0	.9550	-.7876	.7819

2. Tabulation of  $P(\psi, \theta)$  from (4-5)

$\psi = 0.5$		$\psi = 1.0$	
$\theta$	$P(\psi, \theta)$	$\theta$	$P(\psi, \theta)$
0	1.000	0	1.000
0.2	.975	0.2	.981
0.4	.850	0.4	.874
0.6	.710	0.6	.752
0.8	.588	0.8	.642
1.0	.487	1.0	.548
1.5	.303	1.5	.368
2.0	.188	2.0	.247

3. Tabulation of Eigenvalue  $\lambda_1'$  as a function of  $\psi$  (see Appendix C)

$\psi$	<u>First order approx.</u>	<u>Second order approx.</u>
2	.222143	.22685
6	.038013	.09277
3	.023491	.02395
10	.015105	.01531
4	.000994	.000996

4. Evaluation and Tabulation of  $C_1(\psi)$  (See Appendix C)

The coefficient  $C_1(\psi)$  is determined as

$$\frac{\int_0^{\psi} e^{-y^2/2} w_1(y) dy}{\int_0^{\psi} e^{-y^2/2} w_1^2(y) dy}$$

where  $w_1(y)$  is a power series in  $y$  and  $\lambda_1'$ . Therefore, a typical term in the evaluation involves an integral of the form  $\int_0^\psi y^n e^{-y^2/2} dy$ . We may find tabulated in the literature\* the function

$$M_n(x) = \frac{1}{\sqrt{2\pi}(n-1)!!} \int_0^x y^n e^{-y^2/2} dy$$

from which a typical term in the evaluation of  $C_1(\psi)$  can be computed.

$\psi$	$C_1(\psi)$
2	1.0835
6	1.0538
3	1.0208
10	1.0160
4	1.0011

\*The function  $M_n(x)$  for values of  $n$  below 11 is tabulated in reference 19, and for  $n = 11, 12$  in reference 20.

BIBLIOGRAPHY

- 1 - Chance, Hulsizer, MacNichol, and Williams, "Electronic Time Measurements", Radiation Laboratory Series, Vol. 20, Ch.8, McGraw Hill, 1949.
- 2 - Lawson and Uhlenbeck, "Threshold Signals", Radiation Laboratory Series, Vol. 24, McGraw Hill 1950.
- 3 - Rice, S.O., "Filtered Thermal Noise--Fluctuation of Energy as a Function of Interval Length", Journal of the Acoustical Society of America, Vol. 14 (1943).
- 4 - Maximon, L. and Ruina, J., Technical Report No. 1 "Some Statistical Properties of Gated Signal Plus Narrow Band Noise" (Contract Nonr-562(05)) August, 1953.
- 5 - Muchmore, R. B. et al, T.M. 193, Hughes Aircraft Co.
- 6 - Chandrasekhar, S., "Stochastic Problems in Physics and Astronomy", Rev. of Modern Physics, Vol. 15, No. 1, Ch. I and II, (1943).
- 7 - Wang and Uhlenbeck, "On the Theory of Brownian Motion II", Rev. of Modern Physics, Vol. 17, Nos. 2 and 3, (1945).
- 8 - Churchill, R.V., "Fourier Series and Boundary Value Problems", McGraw-Hill, (1941).
- 9 - Olson, F. C. and Schultz, O.T., Industrial and Engineering Chemistry, Vol. 34, p. 874.
- 10 - Ince, E.L., "Ordinary Differential Equations", Dover, (1926).
- 11 - Weber, E., "Electromagnetic Fields", Vol. I, John Wiley, (1950).
- 12 - Whittaker, E.T. and Watson, G.N., "A Course of Modern Analysis", Cambridge, (1927).
- 13 - Jahnke, F. and Emde, E., "Tables of Functions", Dover, (1943).
- 14 - Chandrasekhar, S., "Dynamical Friction II", Astrophysical Journal, Vol. 97, p. 263, (1943).
- 15 - Sommerfeld, A. and Welke, H., "Kunstliche Grenzbedingungen beim Keplerproblem", Annalen der Physik, Vol. 32, p. 56, (1938).
- 16 - Margenau, H. and Murphy, G.V., "The Mathematics of Physics and Chemistry", Van Nostrand, (1943).
- 17 - Pauling, L. and Wilson, E., "Introduction to Quantum Mechanics", McGraw-Hill, (1935).

BIBLIOGRAPHY - cont'd -

- 18.- Lowan, A., and Laderman, J. "Tables of Fourier Coefficients" -  
Journal of Mathematics and Physics, Vol. 22, (1943), p.136.
- 19 - Pearson, K. and Lee, A., "Generalized Probable Error in  
Multiple Normal Correlation", Biometrika, Vol. 6, P. 67(1908)
- 20 - Pearson, K., "Tables for Statisticians and Biometricians, Part II,  
Biometrics Laboratory, University College, London.