

UNCLASSIFIED

AD NUMBER

AD020447

CLASSIFICATION CHANGES

TO: UNCLASSIFIED

FROM: CONFIDENTIAL

LIMITATION CHANGES

TO:  
Approved for public release; distribution is unlimited. Document partially illegible.

FROM:  
Distribution authorized to U.S. Gov't. agencies and their contractors;  
Administrative/Operational Use; AUG 1953. Other requests shall be referred to Office of Naval Research, Washington, DC. Document partially illegible.

AUTHORITY

31 aug 1965, DoDD 5200.10; onr ltr, 26 oct 1977

THIS PAGE IS UNCLASSIFIED

UNCLASSIFIED

AD 20 447

*Reproduced  
by the*

ARMED SERVICES TECHNICAL INFORMATION AGENCY  
ARLINGTON HALL STATION  
ARLINGTON 12, VIRGINIA



DOWNGRADED AT 3 YEAR INTERVALS:  
DECLASSIFIED AFTER 12 YEARS  
DOD DIR 5200.10

UNCLASSIFIED

# Armed Services Technical Information Agency

AD

UNCLASSIFIED

20447

NOTE: WHEN GOVERNMENT OR OTHER DRAWINGS, SPECIFICATIONS OR OTHER DATA ARE USED FOR ANY PURPOSE OTHER THAN IN CONNECTION WITH A DEFINITELY RELATED GOVERNMENT PROCUREMENT OPERATION, THE U. S. GOVERNMENT THEREBY INCURS NO RESPONSIBILITY, NOR ANY OBLIGATION WHATSOEVER; AND THE FACT THAT THE GOVERNMENT MAY HAVE FORMULATED, FURNISHED, OR IN ANY WAY SUPPLIED THE DRAWINGS, SPECIFICATIONS, OR OTHER DATA IS NOT TO BE REGARDED BY ANY PERSON OR CORPORATION, OR CONVEYING ANY RIGHTS OR PERMISSION TO MANUFACTURE, USE OR SELL ANY PATENTED INVENTION THAT MAY IN ANY WAY BE RELATED THERETO.

Reproduced by  
DOCUMENT SERVICE CENTER  
KNOTT BUILDING, DAYTON, 2, OHIO

UNCLASSIFIED

The following ESPIONAGE NOTICE can be disregarded unless this document is plainly marked RESTRICTED, CONFIDENTIAL, or SECRET.

NOTICE: THIS DOCUMENT CONTAINS INFORMATION AFFECTING THE NATIONAL DEFENSE OF THE UNITED STATES WITHIN THE MEANING OF THE ESPIONAGE LAWS, TITLE 18, U.S.C., SECTIONS 793 and 794. THE TRANSMISSION OR THE REVELATION OF ITS CONTENTS IN ANY MANNER TO AN UNAUTHORIZED PERSON IS PROHIBITED BY LAW.

# DISCLAIMER NOTICE

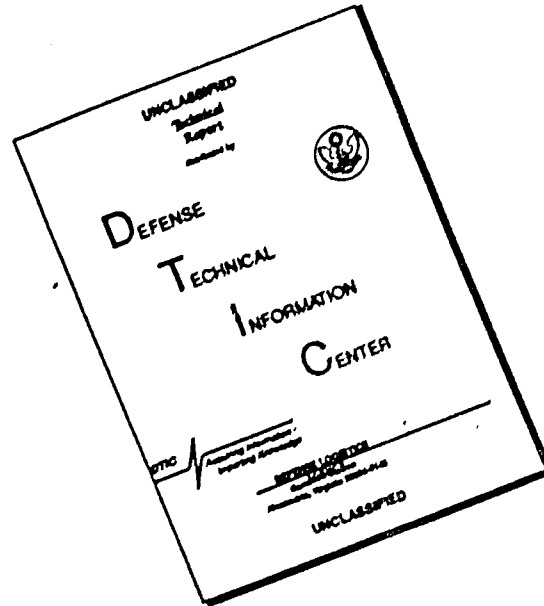

THIS DOCUMENT IS BEST QUALITY AVAILABLE. THE COPY FURNISHED TO DTIC CONTAINED A SIGNIFICANT NUMBER OF PAGES WHICH DO NOT REPRODUCE LEGIBLY.

**UNCLASSIFIED**  
**CONFIDENTIAL**

**NAVY DEPARTMENT**  
**OFFICE OF NAVAL RESEARCH**  
**WASHINGTON, D. C.**

5 August 1953  
Report No. 725  
(Semiannual)  
Copy No. 140

AEC R-725

80447

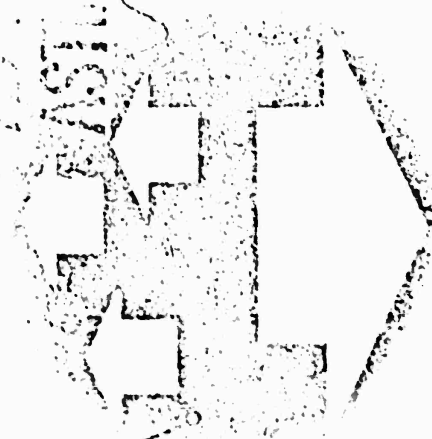

**RESEARCH, DEVELOPMENT**  
**AND TESTING OF**  
**UNDERWATER PROPULSION DEVICES**



**Contract N6ori-10**  
**Task Order No. 1**  
**Project NR097 003**

PROPERTY OF R.O.  
TECHNICAL LIBRARY

*Pratt & Whitney* **General** CORPORATION  
A SUBSIDIARY OF THE GENERAL ELECTRIC COMPANY

**UNCLASSIFIED**  
**CONFIDENTIAL**  
**SECURITY INFORMATION**

**UNCLASSIFIED**

5 August 1953

Report No. 725  
(Semianual)

RESEARCH, DEVELOPMENT, AND TESTING  
OF UNDERWATER PROPULSION DEVICES

Contract N6ori-10  
Task Order I  
Project NR 097 003

Written by:

M. Bielecki  
C. G. Dickens  
H. M. Higgins  
S. G. Krumbholz  
A. E. Lenke  
R. Spies  
B. K. Wilner

No. of Pages: 66

Period Covered:

1 January through 30 June 1953

Approved by:

*C. A. Gongwer*

C. A. Gongwer  
Manager  
Underwater Engine Division

This document contains information affecting the national defense of the United States within the meaning of the Espionage Laws, Title 18, U.S.C., Sections 793 and 794. The transmission or the revelation of its contents in any manner to an unauthorized person is prohibited by law.

AEROJET-GENERAL CORPORATION

Azusa, California

**UNCLASSIFIED**

CONTENTS

	<u>Page</u>
Contract Fulfillment Statement _____	v
<u>INTRODUCTION</u>	
I. OBJECT AND DEFINITIONS _____	2
II. SUMMARY _____	3
III. CONCLUSIONS _____	5
IV. RECOMMENDATIONS _____	7
<u>PART I - ALCLO HYDRODUCT</u>	
I. DESCRIPTION OF WORK _____	2
II. METHOD OF TESTING _____	3
III. RESULTS _____	3
<u>PART II - ALCLO HYDRODUCTOR</u>	
I. DESCRIPTION OF WORK _____	2
II. METHOD OF TESTING _____	3
III. RESULTS _____	3
<u>PART III - ALCLO-FUELED SUBMARINE POWER PLANT</u>	
I. DESCRIPTION OF WORK _____	2
II. METHOD OF TESTING _____	2
III. RESULTS _____	3
<u>PART IV - ALCLO STUDIES</u>	
I. DESCRIPTION OF WORK _____	2
<u>PART V - GASOLINE-AIR HYDROFULSE</u>	
I. DESCRIPTION OF WORK _____	2
II. METHOD OF TESTING _____	4
III. RESULTS _____	5

CONTENTS (cont.)

References

	<u>Table</u>
Particle Size, Aluminum Oxide Content, and Volatile Matter in Aluminum Powder _____	I
	<u>Figure</u>
Schematic Diagram of Alclo Hydroduct _____	1
Standard Test Motor Employing 3.75-in.-dia Grains _____	2
Short-Chamber Test Motor Employing 3.75-in.-dia Grain _____	3
Carbon Turbulator for Short Chamber _____	4
Single-Wall Test Motor Employing 4.75-in.-dia Grain _____	5
Double-Wall Test Motor Employing 4.75-in.-dia Grain _____	6
Alclo Motor Setup for Testing in Static-Test Pit _____	7
Comparative Plot of Burning-Rate Curves for Alclo Propellant _____	8
Schematic Diagram of Alclo Hydroductor _____	9
Test Installation for Prototype Steam-Jet Condenser _____	10
Prototype Steam-Jet Condenser Test Setup _____	11
Hydroductor Test-Pit Setup _____	12
Hydroductor Tail Section _____	13
Typical Hydroductor Static Run _____	14
Closed-Cycle Test Steam Generator _____	15
Test Steam Generator _____	16
Diagram of an Alclo-Fluied Submarine Power Plant _____	17
Burning-Rate Tests with Various Grades of Aluminum _____	18
Particle-Size Distribution Curve for Aluminum Powder _____	19

**CONFIDENTIAL**  
**UNCLASSIFIED**

Report No. 725

CONTENTS (cont.)

	<u>Figure</u>
Micromerograph Results for Various Lead Batches _____	20
Lead Particle Size vs Performance Factor for Alclo _____	21
Effect of Exposure of Potassium Perchlorate to 26% Relative Humidity on Burning Rate of Alclo _____	22
Turbulator-Type Plenum Chamber _____	23
Spark Ignition System _____	24
Air-Valve Assembly, Gasoline-Air Hydropulse _____	25
Hydraulic Valve-Actuation System _____	26
Schematic Diagram of Pneumatic-Hydraulic System _____	27
Typical Indicator Diagram - Gasoline-Air Hydropulse _____	28

**UNCLASSIFIED**  
**CONFIDENTIAL**

CONFIDENTIAL

Report No. 725

CONTRACT FULFILLMENT STATEMENT

This semiannual report is submitted in partial fulfillment of Contract N6ori-10, Task Order I, and covers the period 1 January through 30 June 1953.

Page v

CONFIDENTIAL

CONFIDENTIAL

Report No. 725

INTRODUCTION

CONFIDENTIAL

# CONFIDENTIAL

Report No. 725

## I. OBJECT AND DEFINITIONS

During this report period, research and development work has been conducted on the following underwater propulsion devices and fuels:

### A. HYDRODUCT

1. The vapor-jet hydroduct is an underwater propulsive device in which "free" water, flowing through a submerged duct, either reacts with a hydrofuel to generate steam or is converted to steam by the heat of reaction of a solid propellant. Thrust is produced by the expansion of the steam to ambient pressure. The term "vapor-jet" is used to distinguish the device from hydroducts designed to operate on the expansion of a gas-and-water mixture.

2. The vapor-jet hydroduct is open at both ends, thus permitting a continuous flow of water through it. An initial forward velocity must be imparted to the hydroduct to build up ram pressure before self-operation can be obtained. Development work on the vapor-jet hydroduct has been carried out using Alclo propellant.

### B. HYDRODUCTOR

An underwater missile may be propelled by a jet of high-velocity steam exhausting through a De Laval nozzle. However, as the missile goes down in depth and the back pressure increases, the steam velocity decreases until the thrust of the system deteriorates and the power plant ceases to operate. By condensing the exhaust with a steam-jet condenser, a low back pressure can be maintained and the performance of the missile can be increased and made relatively insensitive to depth of operation. Since the exhaust of the Alclo hydroduct consists of steam and solid reaction products, and is therefore completely condensable, a direct-contact condenser can be applied to the system. When the steam-jet condenser is applied to the hydroduct, the device is termed a hydroductor.

### C. ALCLO-FUELED POWER PLANT

1. The principles of the Alclo-fueled power plant are directly applicable to submarine propulsion. Alclo is a propellant containing both fuel and oxidizer. When burned within a recirculating gas cycle, it gives up its thermal energy to generate steam. The gas within the cycle does not take part in combustion but serves solely as a heat-transfer medium. The products of combustion are all solid and are removed from the gas stream by means of a dust collector. A closed steam cycle, similar to a conventional steam-turbine power plant, is utilized to furnish the required shaft horsepower.

2. A submarine power plant burning this propellant would not require air for its operation, and thus can operate without surfacing for extended periods of time.

Page 2

CONFIDENTIAL

# CONFIDENTIAL

## I Object and Definitions (cont.)

Report No. 725

### D. GASOLINE-AIR HYDROPULSE

The gasoline-air hypopulse is an underwater-propulsion device in which the combustion products of gasoline and air are intermittently generated in a chamber adjacent to a duct and are admitted to the water in the submerged duct. Mechanical check valves are provided at the forward end of the duct. These open to permit the entrance of water during the low-pressure part of the cycle, and close during the high-pressure part of the cycle, causing the expulsion of water from the tailpipe.

## II. SUMMARY

### A. ALCO HYDRODUCT

1. The major work was undertaken on the design and development of a short combustion chamber to be used on the hydroductor missile. It is necessary in the present envelope to decrease the combustion-chamber volume to accommodate the condensing section of the hydroductor. Turbulator and water-entry configurations were studied and the performance was improved, so that the results are comparable to those obtained in the standard motor tests.

2. Work was temporarily halted on the standard motor incorporating water-spray injectors. Some tests were run on spray injectors in the short combustion chamber; it was believed that it might be possible to accommodate the injectors without an increase in missile diameter.

3. Continued successful testing of the hydroduct test vehicle was carried out on the underwater test range of the Naval Ordnance Test Station at Morris Dam. The results of these tests and a description of the work are reported separately under Contract Nonr-1002(00).

4. Work has been done on checking the reliability of the Alco grain. Results have shown the effects of variation in size and type of ingredients. They are discussed in a separate section of this report.

5. Systematic batch checks on all grains pressed have further proved the reliability and reproducibility of the grains.

### B. HYDRODUCTOR

1. Testing of the small-scale steam-jet condenser was concluded. Complete test results were presented in Special Report No. 707, dated 25 May 1953.

2. Numerous tests have been performed on the full-size steam-jet condenser utilizing the 4.5-in.-dia Alco motor. The results have been highly satisfactory and indicate that the performance of the system should at least equal that of the Alco motor alone at surface conditions when developed to the same extent as the hydroduct.

Page 3

CONFIDENTIAL

# CONFIDENTIAL

II Summary, B (cont.)

Report No. 725

3. The Hydroductor Mark I free-running missile has been completely fabricated; range firings at Morris Dam are awaiting final development of the short-combustion-chamber Alclo motor.

4. The steam-accumulator installation on the rotating boom has been checked out for operation; as soon as scheduling permits, tests will be conducted on the model hydroductor.

## C. ALCLO-FUELED POWER PLANT

1. The Alclo-fueled test steam generator was successfully operated with a closed, recirculating gas cycle in several short runs.

2. The unit performed satisfactorily. The ash behavior was as anticipated: slag remained in the furnace while fly-ash was removed in the dust collector.

3. Development work was primarily concerned with the use of Alclo grains in pressed-stick form for firing the test steam generator.

## D. ALCLO STUDIES

1. Development work was continued on Alclo, a propellant consisting of potassium perchlorate and powdered aluminum, for use as a fuel in the hydroductor and in other systems which operate on steam.

2. The program of increasing and also retarding the burning rate of Alclo propellant was continued. Considerable control was made possible by varying particle size and shape.

3. The study of the effect of age, high-temperature storage, moisture, and mechanical shock on the performance of the propellant was continued.

4. Emphasis on control of the materials and processes used in the preparation of Alclo propellant was continued.

5. Considerable work was done in developing a pressing technique which would result in consistently acceptable 3.75-in.-dia grains.

6. Some mechanical improvements were made on the 400-ton hydraulic press and the associated die parts, which resulted in more efficient, safer operation and a better, more uniform product.

## E. GASOLINE-AIR HYDROPULSE

1. A unique fuel-vaporizing device consisting of a fan-turbulator and a small, recycling fuel pump mounted in a cylindrical plenum chamber now provides a compact means of producing the mixture of gasoline vapor and air required in the hydropulse motor.

Page 4

CONFIDENTIAL

# CONFIDENTIAL

II Summary, R (cont.)

Report No. 725

2. A condenser-discharge type of ignition system gives a satisfactory spark and close control of spark timing.

3. The air-control valve has been made more reliable, and the valve has been made to open and close faster. However, the valve is still closing too slowly, inducting too large a charge of compressed air and fuel into the duct, and permitting the air to expand to about one-half its initial pressure before it is ignited.

4. At present, the motor is operating at 5 cps with peak chamber pressure of 250 psi. During the past two months, the static thrust has been increased from 70 to 140 lb at 5 cps.

## III. CONCLUSIONS

### A. ALCLO HYDRODUCT

1. The motor with the short combustion chamber, necessary to accommodate the condensing section of the hydroductor, has proved nearly equal in performance to the standard motor. A few problems remain to be solved before free-running tests are made, but it is expected that they will be solved within the month.

2. The peripheral work on the Alclo grain has made it possible to adjust performance of the motor and increase consistency of results.

3. The performance of the motor can be increased further by development of larger-size motors.

### B. HYDRODUCTOR

The practicability of operating a hydroductor with an Alclo motor has been demonstrated by the results of the test program on the full-scale steam-jet condenser which utilizes a 4.5-in.-dia Alclo motor. Investigations also indicate that the launching requirements of the hydroductor missile are compatible with the starting properties of the system. Comparable performance can be expected from a hydroductor operating at great depth in relation to the performance of a hydroduct of identical size operating near the surface.

### C. ALCLO-FUELED POWER PLANT

1. The successful firing of Alclo within a closed gas cycle of the test steam generator has shown it to be a practical power source for the intended use.

2. The problem of removal of products of combustion appears to be solved by removing the low-melting-temperature slag in the furnace. The ash on the boiler surfaces appears to be loose and flaky, with no apparent tendency to bridge across the boiler passages.

Page 5

CONFIDENTIAL

# CONFIDENTIAL

III Conclusions, C (cont.)

Report No. 725

3. In continuous operation a hot furnace should run off the slag that may accumulate on the boiler tubes facing the furnace.

4. The Alclo-stick method of firing the furnace appears very satisfactory, as evidenced by closed-cycle firings, and future work will be concentrated on this method.

5. Use of pressed Alclo grains results in a volume saving of 50% for propellant storage.

## D. ALCLO STUDIES

1. The high energy density (heat content for a given volume) of Alclo makes it attractive as a source of power for submerged applications. Alclo will permit combinations of speeds and ranges, for a missile or craft of a given displacement, equal to or exceeding those obtainable with any other known type of underwater chemical propulsive system.

2. The burning rate of Alclo can be altered over a wide range to suit a particular application without sacrifices in energy density, by slight alterations in the composition. Sufficient data were obtained to make it possible to predict the composition for any application with fair accuracy. Operation of the hydroduct requires a burning rate near the upper limit of the existing range.

3. If proper control and selection are used, ingredients of commercial quality are acceptable for producing a propellant with a uniformity of performance of  $\pm 2\%$ .

4. Because the reaction products of Alclo are solids after they are condensed, this propellant makes possible missiles which are insensitive to depth and which will leave little or no gaseous wake.

5. Alclo has good storage properties. Ten months of storage at normal conditions caused no deterioration whatsoever. A storage time of 9-1/2 months at 180°F (equivalent to 36 years at normal temperatures) caused a reduction of only 7% in the burning rate.

6. The proper procedures of die loading, die-wall lubricating, and propellant removal must be used if a sound, uniformly compacted propellant is to be obtained.

7. The powdered constituents of Alclo must be free of moisture if best performance is to be obtained.

8. Using know-how and basic performance data gained on this contract (N6ori-10), Aerojet-General Corporation has been able to develop Alclo compositions, under other government contracts, to fill needs in a variety of different applications. For the most part these have been igniter applications, in which Alclo pellets are used as an igniting material for

# CONFIDENTIAL

## III Conclusions, D (cont.)

Report No. 725

solid-propellant rockets. Rocket power plants which use Alclo igniters are being built under Navy Contracts NOas 51-1218, NOas 53-324, NOas 51-1252, NOas 53-935, NOas 52-122c and NOrd 11837, on Air Force Contracts AF33(600)-1967 and AF33(038)-18637, and on miscellaneous subcontracts. In all, more than 120,000 units (equipped with Alclo pellet igniters) have been contracted for production. These include units with thrust ratings up to 33,000 lb.

### E. GASOLINE-AIR HYDROFULSE

1. Reliable fuel vaporization and spark ignition systems have been devised.
2. A non-leaking air valve has been developed which opens sufficiently rapidly but which, with the present actuating system, remains open too long and closes too slowly. These difficulties can be eliminated by modifications now being made of the actuating system. Improved valve operations should double present chamber pressures and thrust.

## IV. RECOMMENDATIONS

### A. ALCLO HYDRODUCT

1. The short combustion chamber, as well as the standard motor, should be re-examined in the light of the test data to determine whether the best configuration is being used.
2. The water-spray injectors should be re-evaluated in an attempt to fit them into the present envelope. There is little doubt that they can be fitted into a 9-in. prototype if that is found to be advantageous.
3. Work should continue on the Alclo grain to help obtain peak performance from the missile.

### B. HYDRODUCTOR

1. The test program on the full-scale steam-jet condenser utilizing the 4.5-in.-dia Alclo motor should be continued and accelerated in order to establish firmly the operating characteristics of the unit.
2. The free-running hydroductor missile should be launched as soon as motor development permits, and the results of this test should determine the path of future development work.
3. A formal program should be instituted for testing of the model hydroductor in conjunction with the steam accumulator installation on the rotating boom.

# CONFIDENTIAL

IV Recommendations (cont.)

Report No. 725

## G. ALCLO-FUELED POWER PLANT

1. The closed gas cycle should be studied during continuous or extended periods of operation. This would indicate any possible difficulties due to ash and these could then be studied and remedied.

2. A heat balance test should be planned and performed to aid in the design of a larger or full-scale steam-generating unit.

3. Some preliminary effort should go into the development of different shapes of Alclo sticks with the thought of efficient propellant storage in mind.

## D. ALCLO STUDIES

1. Continued emphasis should be placed on increasing the range of burning rates of Alclo to both higher and lower values (for a given chamber pressure). In doing this the field of application of Alclo will be increased greatly. By re-examining all the burning-rate data gathered over the last two years and by making a search of the literature it may be possible to determine why certain chemicals cause a decrease in the burning rate while others cause an increase; why some additives produce very stable burning while others cause unstable burning; what materials are likely to produce higher burning rates; and the additives that may produce plateaus in the burning-rate curve.

2. An investigation of the burning characteristics of Alclo at higher pressures should be made. The range of interest is from 1000 to 6000 psi. It is of tremendous interest whether the burning rate continues as an extrapolation of the present data, whether it becomes unstable, or whether a plateau is reached.

3. The program of determining the effect of storage under various conditions in the performance of Alclo propellant should be continued. This phase of the work is important from the standpoint of service evaluation.

4. Emphasis should be placed on maintaining and improving the quality of Alclo propellant. This includes quality control of the ingredients, rigid adherence to proper pressing techniques, and a systematic inspection of the final product. Uniformity of the propellant is considered essential if development of the combustion chamber is to progress properly and efficiently.

5. Further work should be initiated toward the development of a better igniter for the 3.75-in.-dia Alclo grain. Although the present igniter is considered adequate and reliable, indications are that as grain size is increased and as the hydroductor testing progresses the ignition delay will have to be shortened and held within closer tolerances.

## E. GASOLINE-AIR HYDROPULSE

1. The air-valve actuation system should be modified immediately to secure a rapid rate of closing, utilizing either a rotary pilot valve or a

## CONFIDENTIAL

IV Recommendations, E (cont.)

Report No. 725

can. This should permit more efficient use of higher pressure air and produce chamber pressures of 2 to 2-1/2 times those obtained heretofore.

2. The cycling rate must be increased from 5 to 12 or even 15 cps to develop the full power of the motor.

3. Operation of the motor on the boom facility, both static and rotating, should be continued in order to provide data for determining ways of improving performance.

4. A multiple-ducted motor should be developed so that proper phasing of the firings will provide a smooth propulsion system for surface craft.

CONFIDENTIAL

Report No. 725

PART I

ALCLO HYDRODUCT

CONFIDENTIAL

# CONFIDENTIAL

Report No. 75

## I. DESCRIPTION OF WORK

### A. INTRODUCTION

1. A schematic diagram of the standard Alclo hydroduct is given in Figure 1.

2. Cross sections of the standard test motor and the short-chamber motor are shown in Figures 2 and 3.

3. Thrust is developed by the expansion of steam generated by the heat released by the burning Alclo. The Alclo propellant, in the form of a solid cylindrical grain, burns like a cigarette, and the heat of combustion vaporizes the free water, which flows continuously through the duct.

4. The combustion chamber is fitted with the turbulence-producing devices to obtain effective mixing of the water, flame, and hot reaction products. The burning of Alclo produces essentially no gases; the solid reaction products are discharged from the exhaust nozzle into the steam jet.

5. All the Alclo motors are operated as rocket motors, with simulated ram water injected into the combustion chamber from a pressurized water tank. The static tests were made on a thrust stand in the test pit.

### B. DEVELOPMENT OF SHORT CHAMBER

1. To accommodate the condensing section of the 4.5-in. hydroduct it is necessary to reduce the volume of the combustion chamber. A comparison between the standard chamber used on the present 4.5-in. hydroduct and that used on the hydroduct shows that the  $L^*$  must be decreased from about 55 to 18 in. It is evident, then, that much greater turbulence must be artificially induced in the short chamber. For this purpose, various types of turbulators were used. It was found early in the program that a combination of an ensian-type ring and a centrally placed button would induce the necessary turbulence and bring performance nearly up to standard. However, it was necessary to find a substance that would not melt under the high chamber temperatures while also withstanding the erosive action of the gases. After many types of metal were tried and found wanting, pure carbon was tried. While the material has low mechanical strength, it easily withstands the temperature. It has been found that a button machined integrally with the rings will overcome the strength deficiency. Figure 4 shows a button of this type. The optimum configuration should be determined within the month.

2. Besides experimenting with the button-ring combination, the water-spray injection system previously used on the standard motor was tried. It is believed possible to include these injectors within the present dimensions of the short-chamber motor.

Page 2  
Part I

CONFIDENTIAL

# CONFIDENTIAL

2 Description of Work (cont.)

Report No. 75

## C. STANDARD TEST MOTOR USING 3.75-IN.-DIA GRAIN

1. A program of peripheral testing of Alclo grains was undertaken. This program included tests on grains in which known variables in the propellant formulation or processing were imposed; the effect on the performance was determined. A full description of the work and results are reported in the "Alclo Studies" section.

2. In conjunction with the grain pressing work, at least one of every four grains is run in the standard motor for quality control and grain evaluation.

## D. SINGLE-WALL MOTOR USING 4.75-IN.-DIA GRAIN

This motor (Figure 5) is ready, awaiting fabrication of 4.75-in.-dia grains.

## E. DOUBLE-WALL MOTOR USING 4.75-IN.-DIA GRAIN

This motor (Figure 6) is ready awaiting fabrication of 4.75-in.-dia grains.

## II. METHOD OF TESTING

### A. STATIC TESTING OF ALCLO MOTORS

1. The Alclo motor was mounted on a thrust stand in the static-test pit and was operated as a rocket motor, with water supplied to the injector at ram pressure from a pressurized water tank. Cooling water is sprayed over the outside of the motor to simulate the cooling of a free-running test vehicle. The Alclo motor, set up for testing in the static-test pit, is shown in Figure 7.

2. Thrust, chamber pressure, ram pressure, and water flow rate were recorded on a multichannel oscillograph using reluctance-type pressure pickups.

3. Burst diaphragms were fitted in the water intake to the motor to simulate the starting conditions during the booster-launching of a free-running test vehicle.

## III. RESULTS

### A. DEVELOPMENT WORK ON SHORT CHAMBER

1. All work, so far, has been done at an area ratio equal to that used for the standard motor, i.e., 6.75. Theoretically there is no reason why the optimum area ratio should change, but some work must be done to verify this. At the same area ratio, a configuration has been found that

# CONFIDENTIAL

III Results. A (cont.)

Report No. 725

gives a specific impulse of about 320 lb-sec/lb as compared to 330 lb-sec/lb for the standard motor, using a grain pressed the same day as that used in the tests on the short chamber. The values obtained were as follows:

		<u>Thrust, lb</u>	<u>lb-sec/lb</u>	<u>Pressure, psi</u>
Batch 1	Short Chamber	665	319	356
	Standard	645	330	305
Batch 2	Short Chamber	605	326	305
	Standard	606	320	292
	Standard	655	343	310

More work must be done to complete the short-chamber configuration, but the basic design seems to be set.

## B. STANDARD TEST MOTOR USING 3.75-IN.-DIA GRAIN

1. The results of peripheral tests on grain components are fully reported in the "Alclo Studies" section.

2. Quality control checks on the Alclo grains show good consistency in burning rate. The burning rate vs pressure curve should probably be modified somewhat. For the grains pressed during this report period, for which the composition was 75% Grade 606 aluminum and 25% Grade 552 aluminum, the following equation is suggested:

$$r = 0.0039 P_0 + 0.57$$

A comparative plot of the two curves is shown in Figure 8.

CONFIDENTIAL

Report No. 725

PART II

ALCO HYDRODUCTOR

CONFIDENTIAL

# CONFIDENTIAL

Report No. 725

## I. DESCRIPTION OF WORK

### A. INTRODUCTION

A schematic diagram of the Alclo hydroductor, illustrating the principles of operation and giving the nomenclature of the components, is shown in Figure 9.

### B. SMALL-SCALE STEAM-JET CONDENSER

The entire test program on the small-scale steam-jet condenser is completely described in the two previous semiannual reports, References 1 and 2. The experimental results and design data of this basic development program have been presented in a special report, Reference 3, which correlates all the information compiled throughout this phase of the work.

### C. FULL-SCALE STEAM-JET CONDENSER

1. The steam-jet condenser test setup was installed in the static-test pit used for the firing of Alclo motors, and a subsequent testing program was undertaken. The unit was designed from the data compiled on the small-scale installation.

2. The condenser unit was designed for a steam flow rate of about 7.0 lb/sec from the 4.5-in.-dia Alclo motor operating at a chamber pressure of 300 psia. The water-entry passages were designed for a flow rate of 175 lb/sec at a spouting velocity of 150 fps into the condensing chamber.

3. The steam-generating phase of the installation is identical with that of the standard Alclo motor, except that a short combustion chamber is used. As illustrated in Figures 10 and 11, the condensing section fits over the end of the Alclo motor. Water for the condensing chamber is stored in a pressure vessel of about 150-gal capacity. High-pressure nitrogen (2500 psia) is led from storage tanks through a 2-in. pipe, a manually operated plug valve, and into a pressure regulator, where the flow is throttled to maintain the desired water tank pressure. The condensing water is led from the tank through 4-in. pipe and a diaphragm-type valve into the condensing chamber of the motor. This may be seen in Figure 12.

4. Test runs have been made on chambers of various proportions to determine the effect of modeling parameters on both performance and starting properties. The effect of water-to-steam ratio has also been studied. Investigation of the starting phenomenon has been accomplished to a limited degree by maintaining close control of the fluid flows during the transient conditions of the ignition phase.

### D. FREE-RUNNING HYDRODUCTOR

The Hydroductor Mark I free-running missile has been completely fabricated and Morris Dam Range firings are awaiting final development of the short combustion-chamber Alclo motor. An assembly drawing of the hydroductor tail section is shown in Figure 13.

CONFIDENTIAL

Page 2  
Part II

# CONFIDENTIAL

Report No. 725

## II. METHOD OF TESTING

### A. FULL-SCALE STEAM-JET CONDENSER

1. Standard testing procedure for this installation requires that both the water tank for steam generation and the tank for condensing water be completely filled prior to each run. The desired tank pressures are then established by regulating the supply of high-pressure nitrogen. At ignition of the Alclo grain, solenoid valves are actuated to initiate the water flows. The ignition system contains relays and an electronic timer to make possible practically any sequence of flow.

2. During a run, thrust, motor chamber pressure, condensing chamber pressure, both ram pressures, and both water flows are recorded on a multichannel oscillograph using reluctance-type pressure pickups. This type of instrumentation provides a complete history of the run and provides all the data for a performance analysis.

3. The first tests were conducted on a unit having a condensing-water-inlet to condensing-chamber-throat area ratio of 0.70. This area ratio was later varied to investigate its effect on the starting properties of the system. The effects of flow sequence were also studied.

4. High-speed motion pictures were taken of a complete run. An entire run usually lasts about 6 sec, but with this type of photography the action can be slowed down to the extent that the run may be witnessed for about 4 min. In this manner, the ignition phase, the start of steam generation, and finally condensation and stable operation can be visually analyzed. A series of these photographs may be seen in Figure 14.

## III. RESULTS

### A. FULL-SCALE STEAM-JET CONDENSER

1. Tests have been conducted on units having water-inlet to condenser-throat area ratios of 0.90, 0.85, 0.80, 0.75 and 0.70. The results of these tests indicate that the system may be readily started at an area ratio of 0.70. However, at the higher area ratios starting of the system does not seem to be reliable and stable operation has not been consistently achieved. These results are in conformity with the data obtained from the small-scale tests. Indications are that by adjusting the sequence of flows, and possibly by varying the inlet area, rapid starting and stable condensation may be achieved at the higher area ratios.

2. Performance calculations based on the test data indicate that the full-scale steam-jet condenser operates with at least the same performance as the Alclo motor alone under surface conditions. Condensing chamber pressures as low as 18-in. Hg vacuum have been recorded during the runs. The results show that the thrust of the condenser unit always equals or slightly exceeds that of the short-combustion-chamber Alclo motor alone. Values of net thrust of about 500 lb can be achieved.

CONFIDENTIAL

Page 3  
Part II

CONFIDENTIAL

III Results, & (cont.)

Report No. 725

3. The unit in question has been operated many times with no apparent wear or damage to the condensing section from the hot reactions products at ignition.

Page 4  
Part II

CONFIDENTIAL

CONFIDENTIAL

Report No. 725

PART III

ALCLO-FUELED SUBMARINE POWER PLANT

CONFIDENTIAL

# CONFIDENTIAL

Report No. 725

## I. DESCRIPTION OF WORK

### A. INTRODUCTION

1. The Alclo-fueled test steam generator is shown in Figures 15 and 16. Basically, it duplicates the schematic arrangement originally proposed, as shown in Figure 17.

2. Alclo grains in 3/4-in.-OD copper restrictors were used in firings of the test steam generator, as it appeared that the recirculating gas system could be closed more readily using the Alclo in stick form rather than in powdered form.

### B. DESCRIPTION OF TEST EQUIPMENT

1. A small, brick-lined furnace connected to an exhaust stack is used for visual observation and study of Alclo flames.

2. The steam generator is used in firings of closed gas cycles. Alclo grains are fed into the burner located in one of the furnace walls. A boiler above the furnace absorbs the heat of the flame by direct radiation. The gas that is recirculated throughout the system enters the furnace through openings in the refractory walls. It cools the refractory and the flame, and then carries the absorbed heat to heat recovery surfaces not directly exposed to the flame. Ash formed from the combustion of propellant has two constituents, the potassium chloride (KCl) slag, which has a low melting temperature and drops into the slag tank, and aluminum oxide ( $Al_2O_3$ ), a fine powder which is carried by the recirculating gas and is removed from the system by a dust collector. The economizer was installed to lower the temperature of the gas entering the gas recirculating fan. The fan returns the gas to the furnace, and the cycle is repeated.

## II. METHOD OF TESTING

### A. POWDERED PROPELLANT

1. Considerable time was spent in attempts to utilize Alclo in powdered form in the steam generator. Very stable and steady flames were obtained. The small, and consequently, relatively cold furnace permitted some of the material to pass through unburned. These quantities were quite small and usually easily disposed of, but occasionally some of the material, deposited on horizontal surfaces, would burn off rapidly. Because of these puffs the closing of the gas recirculating cycle seemed inadvisable.

### B. SOLID PROPELLANT

1. Solid propellant, in the form of grains, definitely overcame the difficulties with the powdered constituents. After a period of preliminary firing in the open cycle of the test steam generator, the recirculating gas cycle was closed.

Page 2  
Part III

CONFIDENTIAL

# CONFIDENTIAL

II Method of Testing, B (cont.)

Report No. 725

2. The steam generator performed satisfactorily in several short tests. Small amounts of fly-ash in the form of smoke escaped through some of the openings, but for further tests these leaks were sealed and only occasionally were puffs of smoke seen to leave the burner opening.

3. In order to burn a continuous train of solid grain the individual sticks were joined with ferrules. This complicated the feeding into the furnace somewhat, with resultant mechanical difficulties. Eventually it was found that burning from grain to grain can be carried out without actual joining. A simple remote positioner was used to control and feed the grains into the furnace. Based on this a motor-driven feeder is being installed to permit practically automatic feeding of the grains.

### III. RESULTS

A. The closing of the gas recirculating cycle that makes the steam generating unit totally enclosed and self-contained has been accomplished.

B. The results of tests are satisfactory, and behavior of the unit is as anticipated. The furnace, apart from the expected slag and grain restrictor material on the floor, remained clean. The boiler surfaces facing the furnace became coated with a loose film of aluminum oxide that did not appear to increase during successive firings. Throughout the cycle other surfaces remained relatively free of any accumulations. The dust collector separated a considerable quantity of fly-ash or "smoke" from the gas stream. There are no evidences of adverse effects on the equipment as the result of the high Alclo flame temperatures.

C. Closed cycle tests are continuing to ascertain whether the slag on the boiler surfaces could become troublesome during extended periods of operation.

D. Solid grains of Alclo have several advantages over the powdered constituents. The problem of incomplete combustion is entirely eliminated, as is the continuous proportioning and mixing of the ingredients. The largest gain is perhaps in the fact that a solid propellant would ultimately reduce the storage requirements in a submarine power plant installation by approximately 50% in comparison with the space required for powdered constituents.

CONFIDENTIAL

Report No. 75

PART IV

ALCLO STUDIES

CONFIDENTIAL

# CONFIDENTIAL

Report No. 725

## I. DESCRIPTION OF WORK

### A. BASIC STUDIES OF BALLISTIC PERFORMANCE

#### 1. Introduction

a. The program for both increasing and decreasing the burning rate of Alcoa propellant was continued. The primary approach was to test the effect of aluminum powder of various particle sizes and particle shapes on the burning rate.

b. Considerable work was done to determine the effect on the burning rate caused by variations in the ingredients due to manufacturing tolerances. Attention was directed specifically toward the aluminum and the lead.

c. The study of the effect of age, high-temperature storage, moisture, and mechanical shock on the performance of the propellant was continued.

#### 2. Effect of Particle Sizes and Shape of Aluminum on the Burning Characteristics of Alcoa

a. Work on this phase during this report period dealt exclusively with the promising type 552 aluminum flake powder and the granular type 101 powder. The Alcoa Catalog descriptions, together with that of the "standard" type 606 aluminum, are tabulated below:

<u>Alcoa No.</u>	<u>Mesh Designation and Type</u>	<u>Average Mesh Size</u>
606	100-mesh unpolished flake powder (low grease)	90% through 325
552	325-mesh polished flake powder (low grease)	97% through 325
101	100-mesh granular powder	80% through 325

b. Burning-rate tests were conducted over a wide range of pressures (0 to 1000 psig) on these mixtures, which were identical in composition except for the type of aluminum used. A plot of burning rate vs pressure for these mixtures is shown in Figure 18.

c. It will be noticed that the finest aluminum, Type 552, produces burning rates that are appreciably greater than those attained with the standard aluminum.

d. Although the particle size of the Type 101 aluminum does not differ greatly from that of Type 606, the burning rate resulting from its use is much less.

Page 2  
Part IV

# CONFIDENTIAL

# CONFIDENTIAL

I Description of Work, & (cont.)

Report No. 723

e. Using the standard formulation, as in the above tests (31.4% aluminum, 55.3% potassium perchlorate, and 12.8% lead), mixtures were made and tested in which the aluminum content comprised Type 606 and Type 552 in varying proportions, from 100% of one to 100% of the other. Similar tests were made on propellant grains containing mixtures of Type 606 and Type 101 aluminum. In both instances, a plot of the data showed that the resulting burning rate at any pressure varied linearly with the proportion of each type of aluminum between the extremes. Thus it can be seen that the burning rate of Alclo at any given pressure can be varied throughout the range indicated in Figure 18 solely by varying the proportions of the grades of aluminum in the mixture.

### 3. Effect of Variations between Lots of Aluminum of the Same Grade on the Burning Rate

a. The burning rate vs pressure curves obtained from Alclo mixtures made with four different lots of aluminum powder were compared. The differences were negligible and well within the inherent experimental errors.

b. Chemical and physical analyses were performed on all the different barrels of Type 606 aluminum. Measurements were made of the percentage of aluminum oxide and volatile matter, and the particle-size distribution. The specific surface and the geometric mean diameter of the particles were calculated. These data are presented in Table I.

c. The percentage of aluminum oxide was determined as follows. The aluminum, plus impurities such as oxide, was heated in the presence of hydrochloric acid for 3 hr at 400°C to produce the following chemical change:

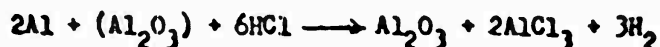

The aluminum chloride decomposes and is released with the hydrogen, leaving only aluminum oxide, which is then heated to 1000°C to drive off any moisture or traces of other metal chlorides.

d. The percentage of volatile matter in the aluminum powder was determined by holding a weighed sample at 100°C for 3 hr, during which time the volatiles are driven off. The sample was then reweighed, and the percentage of volatiles was calculated from the difference.

e. Particle size distribution was determined by means of a Micromerograph analyzer, which operates according to Stokes's law of settling for spheres. Because the aluminum powder is composed of particles of the flake or thin disk form, the true diameter of one of the plates is not the particle size listed, but it is proportional to that particle size. These values give a true picture when materials of like grades or types are compared. The geometric mean particle diameter listed is the diameter that 50% of the material by weight is less than. A typical particle-size distribution curve is

Page 3  
Part IV

# CONFIDENTIAL

# CONFIDENTIAL

I Description of Work, A (cont.)

Report No. 725

shown in Figure 19. The specific surface was calculated from the particle sizes measured, with the assumption that the particles were spherical. Again, the values are only relative.

f. It is seen from these tests that the aluminum powder varies as much between different barrels of the same lot as it does between different lots. It was concluded that the sampling technique and the analyses introduced errors which were sufficient to obscure the differences, if any, between lots of powder.

## 4. Effect of Particle Size of Lead Powder on the Burning Rate

a. The particle-size distribution of five batches of lead powder which varied widely were measured using the micromerograph. The results of these measurements are shown in Figure 20. Alclo grains were formulated using these different batches, holding all other factors relatively constant. The burning rates obtained with each were compared with the "standard" burning rate vs pressure curve in order to obtain a relative performance factor. A plot of geometric mean particle size of lead vs performance factor is shown in Figure 21.

b. It is seen that variation of the particle-size distribution of the lead powder is an effective way of adjusting the burning rate of Alclo within the limits indicated.

## 5. Effect of Moisture on the Burning Rate of Alclo

The effect of moisture on the burning rate of Alclo was investigated. Prior to incorporation into mixtures the potassium perchlorate was spread out in a thin layer in a pan and placed outdoors where it could pick up moisture from the atmosphere. Propellant batches were made with oxidizers which had been exposed to a relative humidity of 26% for 1, 2, and 3 hr. Tests showed that the burning rate was lowered by approximately 2-1/2% per hour of exposure. Figure 22 is a plot of the test data.

## 6. Effect of Long-Term Storage on Alclo Propellant Grains

a. The program of determining the storage properties of Alclo was continued. A grain which had been stored at ambient temperature (40 to 90°F) for a period of 10 months was tested in a standard combustion chamber. The performance was normal in every respect.

b. Two grains which had been stored at a temperature of 180°F for 9-1/2 months were tested as above. Both grains proved to be normal with respect to specific impulse, but the burning rates had suffered a 7% decrease due to the storage.

c. In calculating the equivalent ambient (80°F) storage time for the grains stored at 180°F, methods reported in Reference 2 were used as follows:

Page 4  
Part IV

CONFIDENTIAL

# CONFIDENTIAL

I Description of Work. A (cont.)

Report No. 725

$$\begin{aligned} D_{s_1} &= D_{s_2} \times 2^{0.1(T_2 - T_1)} \\ &= \frac{9.5}{12} \times 2^{0.1(82-27)} \\ &= 3\frac{1}{2} \text{ years} \end{aligned}$$

where

D = duration, yr

T<sub>1</sub> = normal temperature, °C

T<sub>2</sub> = storage temperature, °C

Assuming that this method of comparing storage times is fairly reliable, the effect of normal storage would be to decrease the burning rate by only 0.20% per year.

## 7. Effect of High Acceleration Loads on Alclo Grains

a. Work was continued on the program to determine the ability of an Alclo grain to resist the strains imparted during the rapid acceleration encountered during the booster phase of the free-running missiles. In the present complete grain assembly, the restriction, with its steel reinforcing wires, is designed to assume nearly all of this load.

b. Although the acceleration during the booster phase of the missile is 60 g, to check the safety factor two Alclo grains were accelerated to 300 g, the limit of the available test equipment. Actually the program consisted of imposing an instantaneous peak acceleration of 300 g twice, then 10 successive peaks of 150 g on each grain. They were then inspected for apparent failures and tested in the standard test motor. Both of these grains performed normally in every respect.

## B. PREPARATION OF GRAINS FOR HYDRADUCT TEST-FIRINGS

### 1. Introduction

a. Continued emphasis was placed on control of all materials and of each process in order to make the performance of the grains as uniform and reliable as possible.

b. Much progress was made in improving the physical uniformity of the propellant grains. This program included improvement of the pressing technique and development of better die design, aided by rigid inspection and testing under closely controlled conditions.

# CONFIDENTIAL

I Description of Work, B (cont.)

Report No. 725

## 2. Quality Control of the Constituents

In addition to the inspections listed in Reference 2, the particle-size distribution of the lead is checked for each batch, and if found unacceptable the lead is rejected. Batches of lead whose geometric mean particle size is greater than 10 microns are considered unacceptable for use in standard Alclo grains.

## 3. Improvement in Quality of Grains

a. A new set of 3.75-in.-dia three-split dies were placed in operation during the first part of June. This set of dies was designed with foremost consideration given to the problem of uniform release of the compacted material. The use of this set of dies has resulted in grains of consistently higher quality.

b. Laminary fractures have been eliminated by the exercise of care in using the correct procedures which have been developed for matting flake-type aluminum powders. The most important of these are even die charge, dwell time, and die-wall lubrication.

c. The use of a pneumatic vibrator to settle the powder in the die cavity has been discontinued. While physical improvement in the grain was noted as a result of this procedure, an undesired burning-rate irregularity was caused. This is believed to be the result of the lead powder separating out of the mixture during vibration.

d. Very small, irregular cracks which were encountered on the bottom face of some of the 3.75-in.-dia grains have been completely eliminated. The most important factors in accomplishing this are the use of the new dies described in Paragraph (a) and the continued care in even die charge.

## 4. Propellant Presses

a. The 400-ton press has been operated continuously during this report period for the preparation of 3.75-in.-dia grains with minimum down-time for minor modifications to the press and the press house. A total of three hundred ninety-seven 3.75-in.-dia grains were pressed, averaging 8.25 in. in length and 9.0 lb in weight. In general, the operating procedures for the 400-ton press described in Reference 4 are still in effect.

b. The 20-ton press has been in operation continuously during this report period. It was used in making burning-rate strands for experimental Alclo batches, for preparing Alclo charges for the Alclo steam power plant, and for preparing experimental Alclo propellant for igniters.

CONFIDENTIAL

Report No. 75

PART V

GASOLINE-AIR HYDRO-TLSE

CONFIDENTIAL

# CONFIDENTIAL

Report No. T25

## I. DESCRIPTION OF WORK

### A. COMBUSTION DEVELOPMENT

1. A type of injector used in a German pulse-jet engine during World War II, known as the Schmidt injector, was adapted for installation in the plenum chamber above the vaporizing screens. Fuel flows into this injector continuously, is stored in a metallic wick, and is sprayed out intermittently by ram pressure as air is valved through the chamber. The injector handled the fuel properly, but apparently produced no better vaporization, and performance of the motor was not improved. Moving this injector farther upstream into the air manifold produced no improvement.

2. Since the problem appeared to be the production of large quantities of fuel vapor without the benefit of the high temperatures existing during compression in a reciprocating engine, the plenum chamber was modified radically to produce this vapor. The modified chamber is shown in Figure 23. Fuel is sprayed into the top of the chamber through an air-atomizing injector. The fuel droplets fall through the blades of a small, motor-driven, fan turbulator. Any fuel that is in vapor form is carried along by the moving air stream, but liquid droplets are thrown outward by centrifugal action onto a cylindrical metal screen which surrounds the fan. These drops flow down the screen, the unvaporized portion falling into a sump which drains into the inlet of a small centrifugal pump mounted on the lower end of the fan shaft, and is pumped back up to the injector. This device prevents any liquid fuel from being carried into the combustion chamber with the air stream. It recycles the liquid fuel until it has absorbed enough heat from the air to vaporize.

3. In a plenum chamber with screens or a wick, without a turbulator, gasoline evaporation takes place at a rapid rate only when the air is moving, i.e., when it is being inducted into the combustion chamber. With the turbulator and pump, the gasoline is being sprayed continuously and the air is in constant motion relative to the gasoline, thereby producing rapid gasoline vaporization throughout the entire cycle, rather than only during air induction. With the installation of this turbulator, combustion improved immediately, fuel consumption decreased, and firing became regular.

4. The turbulator-type vaporizer was improved by making a double-wall cylindrical wire screen, the annular space being packed with small pellets of porous aluminum oxide ceramic material to provide more surface for fuel absorption.

5. Measurement of the temperature above and below the plenum chamber showed that the air temperature dropped 30 to 50°F in passing through the chamber, depending on the fuel needle-valve setting. The theoretical air-temperature drop necessary to vaporize gasoline with a 15:1 air-to-fuel ratio is 45°F, which indicates that the plenum chamber is vaporizing the fuel efficiently.

Page 2  
Part V

CONFIDENTIAL

# CONFIDENTIAL

## I Description of Work. A (cont.)

Report No. 725

6. As designed, the air-gas bubble was generated partly in a combustion chamber of 20 cu in. capacity and partly in the water duct. It was believed that the water might be causing quenching of the burning bubble, and the chamber was therefore enlarged to 120 cu in. to contain the entire charge. There was no improvement in combustion, and the expanded, burned gases produced too large a bubble, interfering with refilling of the duct with water. The chamber was restored to its original size.

### B. IMPROVEMENTS IN IGNITION SYSTEM

1. Previous experience with the ignition of gasoline-air mixtures under water has shown that an igniting spark of higher amperage than that used in automotive practice is desirable.

2. The spark was supplied by a 10-kv ignition transformer, timed by the closing of the primary circuit. The spark fired on the first voltage peak of the secondary circuit, and could vary as much as 8 millisees from the time of closing, thus producing erratic spark timing.

3. A condenser discharge system was selected, so that the spark would fire instantly when the discharge circuit was closed. To supply the high-energy spark desired, a simple electronic circuit was built, utilizing a full-wave vacuum-tube rectifier to charge a 0.2 mfd condenser. The schematic wiring diagram is shown in Figure 24. It might appear that control of the spark by a switch in the 5-kv secondary circuit might be a source of trouble. However, switch contact deterioration most frequently occurs when the circuit is broken, rather than when it is closed. In this application the condenser has already been discharged when the switch opens. A double-break switch is used, which gives more rapid opening and closing. The switch is mounted on the valve stem and fires the spark at the instant the valve seats. With this arrangement no deterioration of the ignition components has been observed.

### C. IMPROVEMENTS IN AIR VALVE OPERATION

1. The double-beat poppet valve, used originally to valve the high-pressure air, leaked badly after a short period of service. It was extremely difficult to maintain an even pressure on the two seats.

2. A conventional automotive poppet valve seating on one metallic seat corrected this trouble. No further trouble with leaking occurred. The new valve is lighter, permitting faster actuation. An assembly of the new valve, equipped for hydraulic actuation, is shown in Figure 25.

3. Because it was unbalanced the new valve required a heavier spring, and the Bosch oil pump used for actuation of the double-beat valve was unable to lift the new valve against this spring load. An alternate hydraulic-actuation system was built, using a Vickers piston-type oil pump to maintain a constant supply of oil at 1100 psi pressure. A small solenoid pilot valve is energized intermittently to permit the high-pressure oil to flow to the air valve and lift it. In the de-energized position, the solenoid valve

Page 3  
Part V

CONFIDENTIAL

# CONFIDENTIAL

I Description of Work, C (cont.)

Report No. 725

bleeds off the actuating oil, permitting the air valve to close. The solenoid valve is controlled by a motor-driven cam which closes the contacts of a microswitch to energize the solenoid. Valve cycling speed is controlled by varying the rpm of the cam. The length of time the valve remains open can be adjusted by moving the microswitch in or out from the cam face. A schematic diagram of the system is shown in Figure 26. The system is satisfactory, except that the valve closes too slowly even when adjusted for the minimum period. Analysis of the dynamics of the system shows that the solenoid valve is the cause of the slow closing of the air valve. No faster-acting solenoid valve is available commercially, so two alternate systems are being fabricated to permit faster valve closing.

4. A rotary pilot valve has been designed and is being fabricated. The position of the port which bleeds off the hydraulic oil will be adjustable, so that all delay in bleeding off the oil may be eliminated.

5. Another system, in which the air valve is actuated directly by a cam, is also under construction. After tests the better of the two new systems will be selected. The cam will be of 3-in. dia to permit a ramp of reasonable slope to open the valve 0.5 in. over the 20 degrees of crank angle. The ramp is followed by a cliff to permit the fastest possible closing of the valve under its spring action. The cam is undercut to avoid follower contact at this point, so that the closing shock is taken by the valve seat rather than by the camshaft bearings.

## II. METHOD OF TESTING

A. For testing, the motor is mounted at the 40 ft radius of the rotating boom facility, and air and gasoline are supplied to the motor, as shown in Figure 27.

B. Most tests have been made with the boom secured in a static position for convenience in adjusting the controls, and to permit observation through the underwater windows.

C. All controls and instrumentation have been mounted on the boom. The motor has been rotated for testing, when desired.

D. For both static and dynamic tests, chamber pressure is measured by a diaphragm-reluctance type of pressure pickup, and recorded on an oscillograph. A flexible section is provided in the air piping between the boom and the motor, so that thrust and drag can be measured by a variable-reluctance element coupled to an indicating motor.

E. Rate of flow of compressed air into the motor is determined by measuring the pressure drop in the air storage system during a known time interval. Since the storage volume is known, the weight of air withdrawn from the system can be computed. The rate of air consumption is small relative to the total volume, so that expansion is assumed to be isothermal. Cycling rate is determined from the oscillograph pressure records, so that the air consumption per cycle can be computed.

Page 4  
Part V

CONFIDENTIAL

# CONFIDENTIAL

Report No. 725

## III. RESULTS

A. Ordinary white gasoline, now used for fuel, is vaporized efficiently in the turbulator-plenum chamber. A continuous supply of fuel vapor is now available, so that steady firing of the motor may be secured at a frequency of 5 cps, with fuel consumption reduced by approximately 50% over previous fuel injection systems.

B. When thrust measurements were first started, 70 lb maximum thrust was obtained. This has since been increased to 110 lb.

C. The solid line in Figure 28 shows an actual oscillograph record of chamber pressure plotted against time. The peak combustion pressure now being obtained is about 250 psi, with an injection air pressure of 60 psig. Ignition of the charge takes place at the instant the valve seats, at the point marked on the pressure record. In this record, which is typical, the air valve has closed so slowly that the air pressure in the chamber has dropped to 30 psig at the time of ignition.

D. The dotted line in Figure 28 shows the pressure record that should be obtainable if the theoretical minimum valve closing time were obtained by means of one of the two new actuation systems now under construction. Only 5 psi of injection air pressure would be lost before ignition occurs, and with the same ratio of ignition to combustion pressure, a peak pressure of 410 psi should be obtainable.

E. At present, the fuel-air charge injected into the motor is too large. The rapid valve closure will limit the charge to the proper size and draw less fuel vapor from the plenum chamber each cycle. Thus, sufficient carburetion capacity will be available to use 90- or 100-psi air, instead of 60-psi, with a proportional increase in combustion pressure to 550 to 600 psi.

Page 5  
Part V

CONFIDENTIAL

# CONFIDENTIAL

Report No. 725

## REFERENCES

1. Research, Development, and Testing of Underwater Propulsion Devices.  
Aerojet Report No. 631, 12 August 1952 (Confidential).
2. Research, Development, and Testing of Underwater Propulsion Devices.  
Aerojet Report No. 675, 9 February 1953 (Confidential).
3. Steam-Jet Condenser for Hydroductor Propulsion System.  
Aerojet Report No. 707, 25 May 1953 (Confidential).
4. Research, Development, and Testing of Underwater Propulsion Devices.  
Aerojet Report No. 533, 15 August 1951 (Confidential).

CONFIDENTIAL

CONFIDENTIAL

Report No. 725

TABLE I  
 PARTICLE SIZE, ALUMINUM OXIDE CONTENT,  
 AND VOLATILE MATTER IN ALUMINUM POWDER

<u>Lot</u>	<u>Bbl.</u>	<u>Av % Al<sub>2</sub>O<sub>3</sub></u>	<u>Av % Volatile</u>	<u>Specific Surface Em<sup>2</sup>g<sup>-1</sup></u>	<u>Geometric Mean Particle Diameter microns</u>
2-M-30-A-2	2137	3.55	0.150	2237	11.3
"	2188	3.75	0.155	2272	11.2
"	2190	3.20	0.130	1856	13.7
"	2191	3.90	0.135	1831	13.6
"	2394	3.50	0.130	2002	12.8
"	4325	4.40	0.130	2765	9.3
"	4326	3.65	0.125	2564	10.0
"	4327	3.90	0.125	1961	12.9
"	4328	3.70	0.115	1927	13.3
"	4329	3.50	0.130	1885	13.4
2-O-11-A-1	2396	3.50	0.150	1633	15.3
2-R-20-E-1	5674	3.60	0.110	1748	14.3
"	5675	2.65	0.115	1622	15.4
"	5676	3.55	0.110	1824	13.8
2-R-27-E-1	9766	4.05	0.135	1812	13.9
"	9767	4.20	0.150	1737	14.6
"	9768	3.95	0.140	2153	11.8
"	9769	4.40	0.120	2234	11.3
"	9770	3.65	0.190	2194	11.4

Table I

CONFIDENTIAL

C-4151 12-23-52 BK EGL

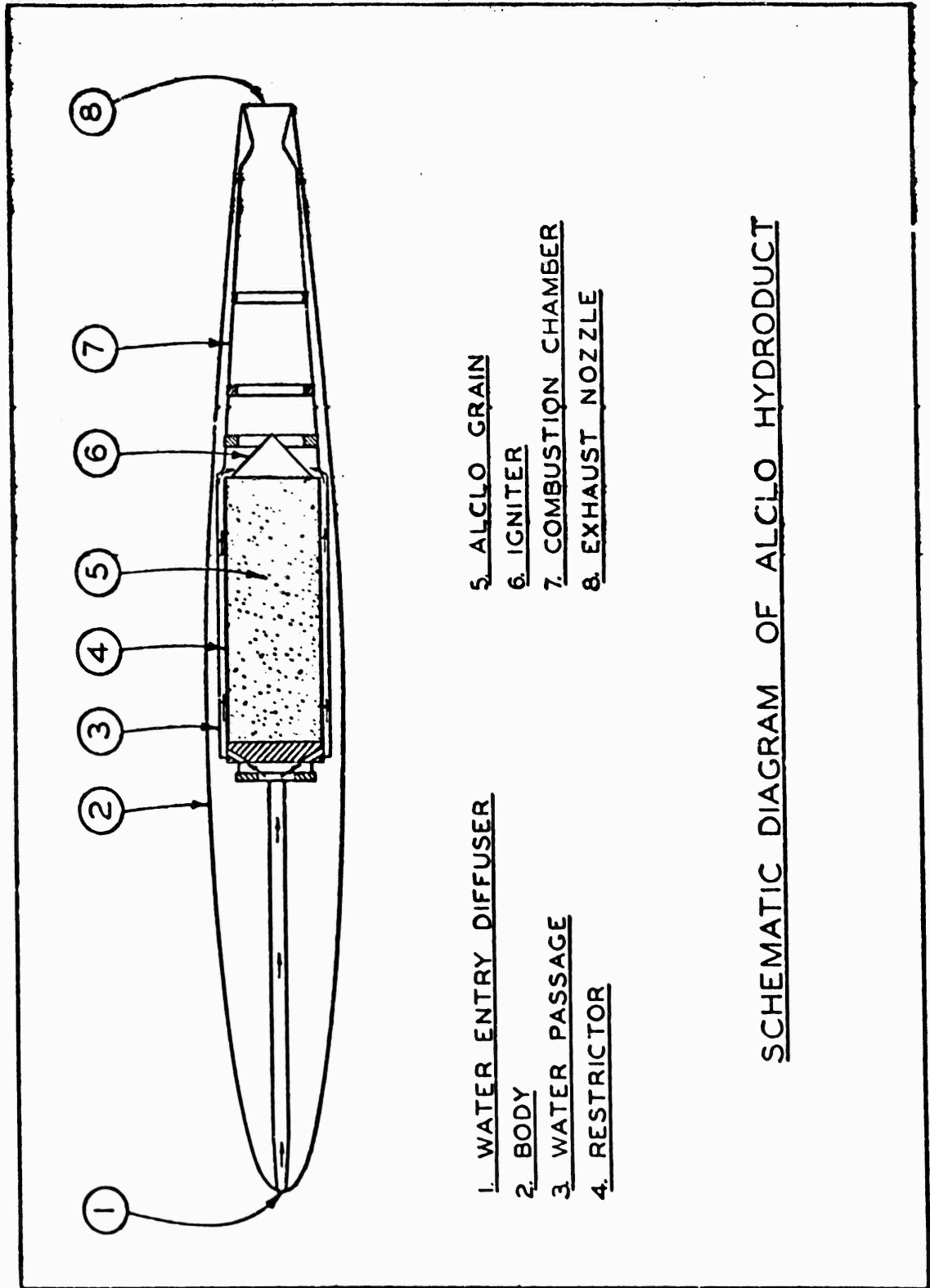

SCHEMATIC DIAGRAM OF ALCLO HYDRODUCT

Figure 1

CONFIDENTIAL

CONFIDENTIAL

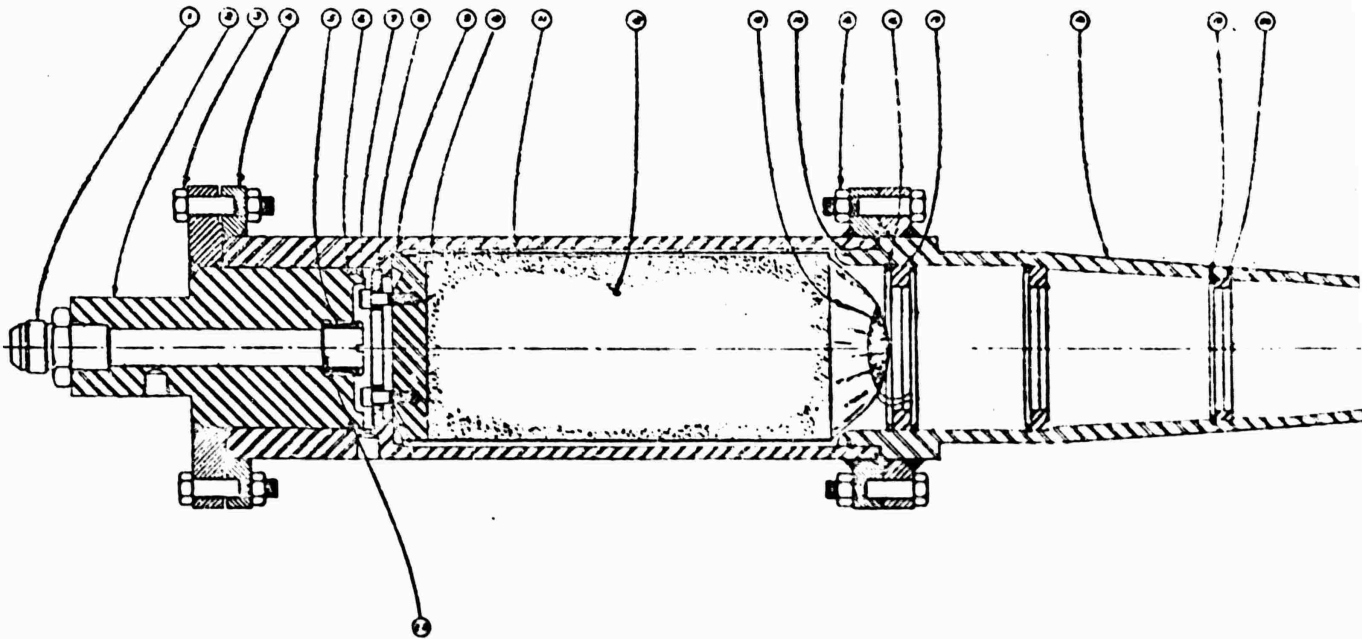

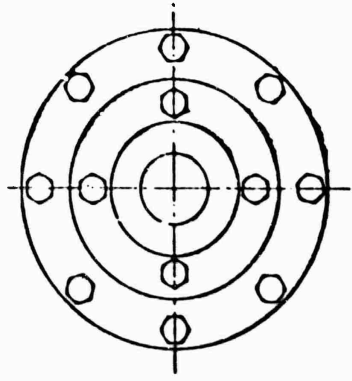
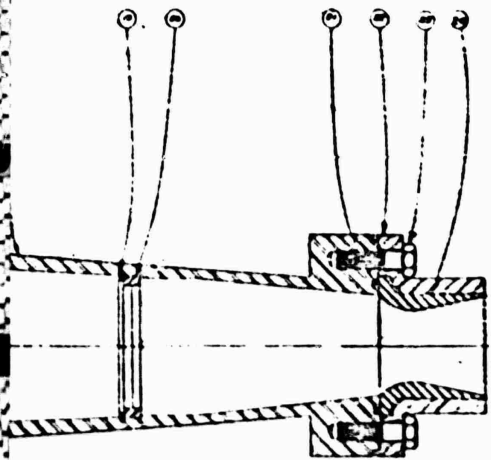

23	COVER	AS 22-1077-0
24	WASHER	AS 22-1077-0
25	NUT	AS 22-1077-0
26	SCREW	AS 22-1077-0
27	SCREW	AS 22-1077-0
28	SCREW	AS 22-1077-0
29	SCREW	AS 22-1077-0
30	SCREW	AS 22-1077-0
31	SCREW	AS 22-1077-0
32	SCREW	AS 22-1077-0
33	SCREW	AS 22-1077-0
34	SCREW	AS 22-1077-0
35	SCREW	AS 22-1077-0
36	SCREW	AS 22-1077-0
37	SCREW	AS 22-1077-0
38	SCREW	AS 22-1077-0
39	SCREW	AS 22-1077-0
40	SCREW	AS 22-1077-0
41	SCREW	AS 22-1077-0
42	SCREW	AS 22-1077-0
43	SCREW	AS 22-1077-0
44	SCREW	AS 22-1077-0
45	SCREW	AS 22-1077-0
46	SCREW	AS 22-1077-0
47	SCREW	AS 22-1077-0
48	SCREW	AS 22-1077-0
49	SCREW	AS 22-1077-0
50	SCREW	AS 22-1077-0

51	SCREW	AS 22-1077-0
52	SCREW	AS 22-1077-0
53	SCREW	AS 22-1077-0
54	SCREW	AS 22-1077-0
55	SCREW	AS 22-1077-0
56	SCREW	AS 22-1077-0
57	SCREW	AS 22-1077-0
58	SCREW	AS 22-1077-0
59	SCREW	AS 22-1077-0
60	SCREW	AS 22-1077-0
61	SCREW	AS 22-1077-0
62	SCREW	AS 22-1077-0
63	SCREW	AS 22-1077-0
64	SCREW	AS 22-1077-0
65	SCREW	AS 22-1077-0
66	SCREW	AS 22-1077-0
67	SCREW	AS 22-1077-0
68	SCREW	AS 22-1077-0
69	SCREW	AS 22-1077-0
70	SCREW	AS 22-1077-0

100 BEYOND THIS

71	SCREW	AS 22-1077-0
72	SCREW	AS 22-1077-0
73	SCREW	AS 22-1077-0
74	SCREW	AS 22-1077-0
75	SCREW	AS 22-1077-0
76	SCREW	AS 22-1077-0
77	SCREW	AS 22-1077-0
78	SCREW	AS 22-1077-0
79	SCREW	AS 22-1077-0
80	SCREW	AS 22-1077-0
81	SCREW	AS 22-1077-0
82	SCREW	AS 22-1077-0
83	SCREW	AS 22-1077-0
84	SCREW	AS 22-1077-0
85	SCREW	AS 22-1077-0
86	SCREW	AS 22-1077-0
87	SCREW	AS 22-1077-0
88	SCREW	AS 22-1077-0
89	SCREW	AS 22-1077-0
90	SCREW	AS 22-1077-0

2

CONFIDENTIAL

Figure 2

CONFIDENTIAL

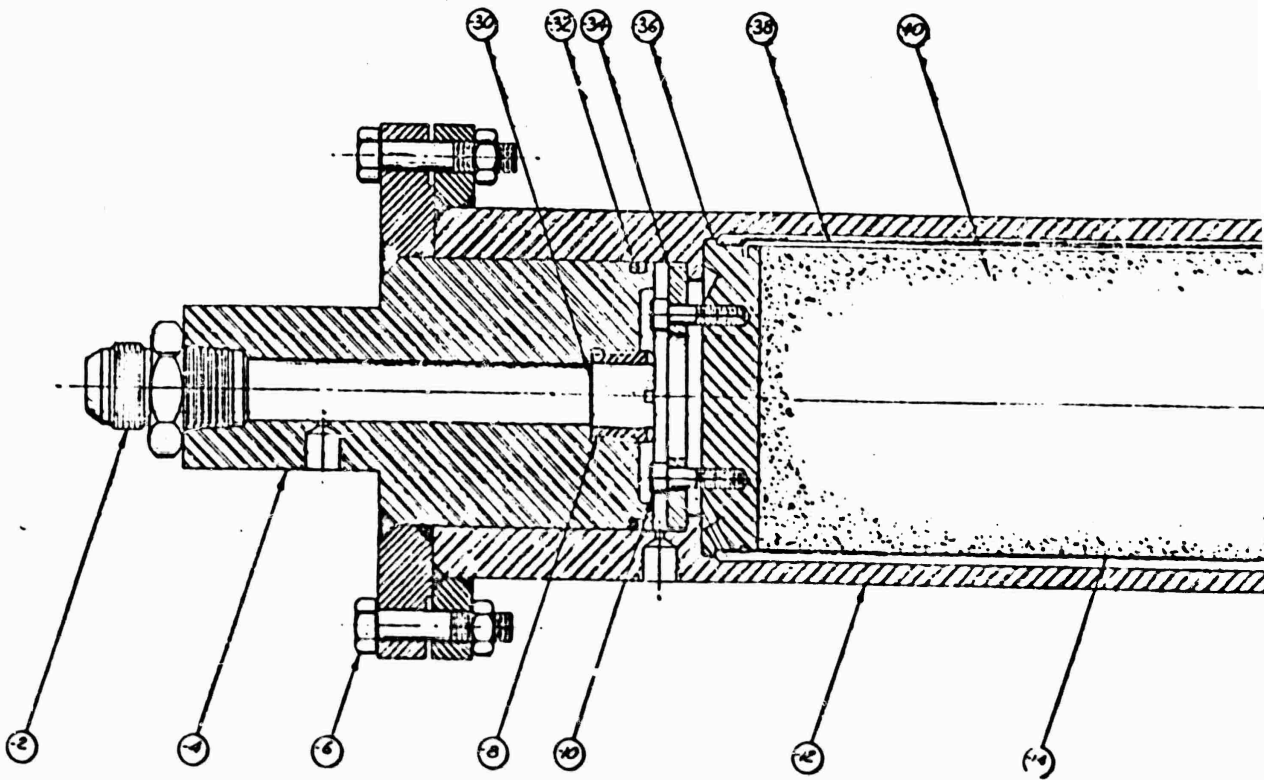

CONFIDENTIAL



UNCLASSIFIED

Report No. 725

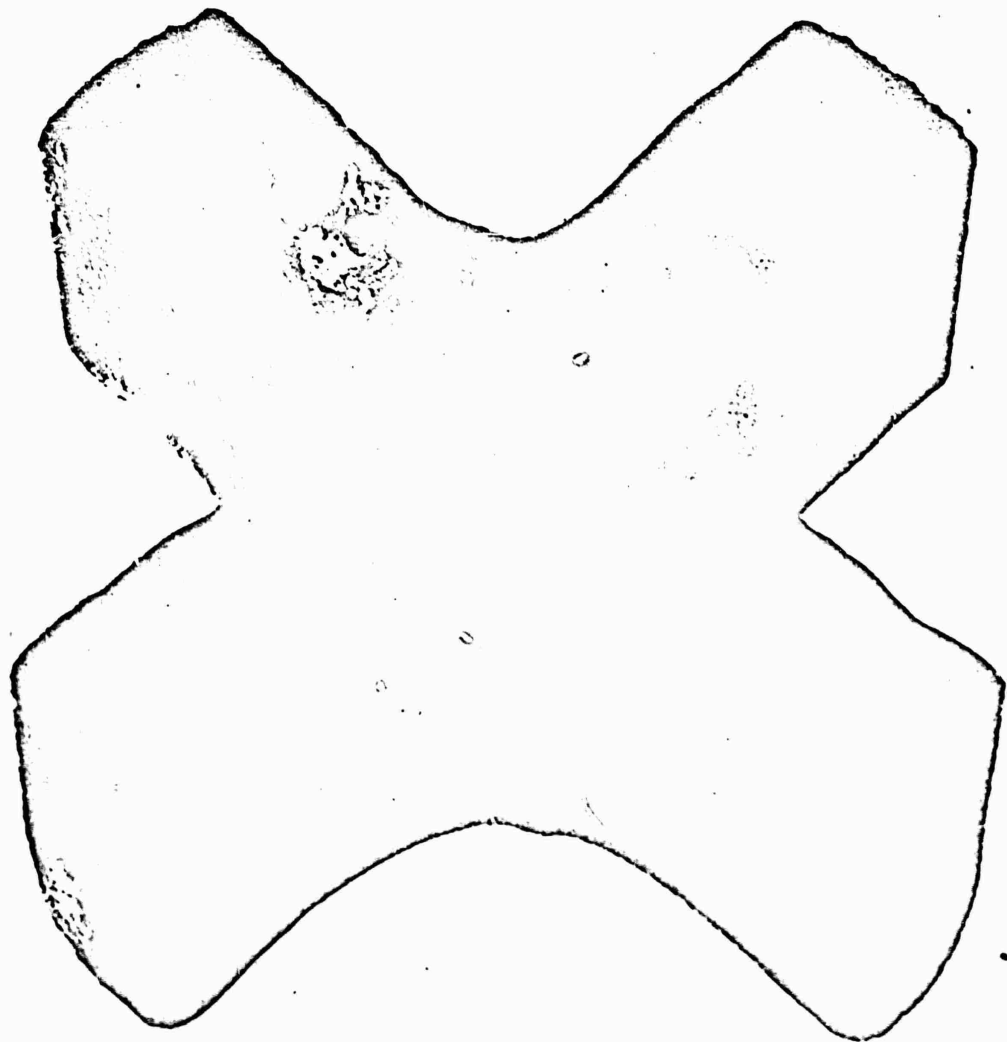

0653-410

Carbon Turbulator for Short Chamber

Figure 4

UNCLASSIFIED

CONFIDENTIAL

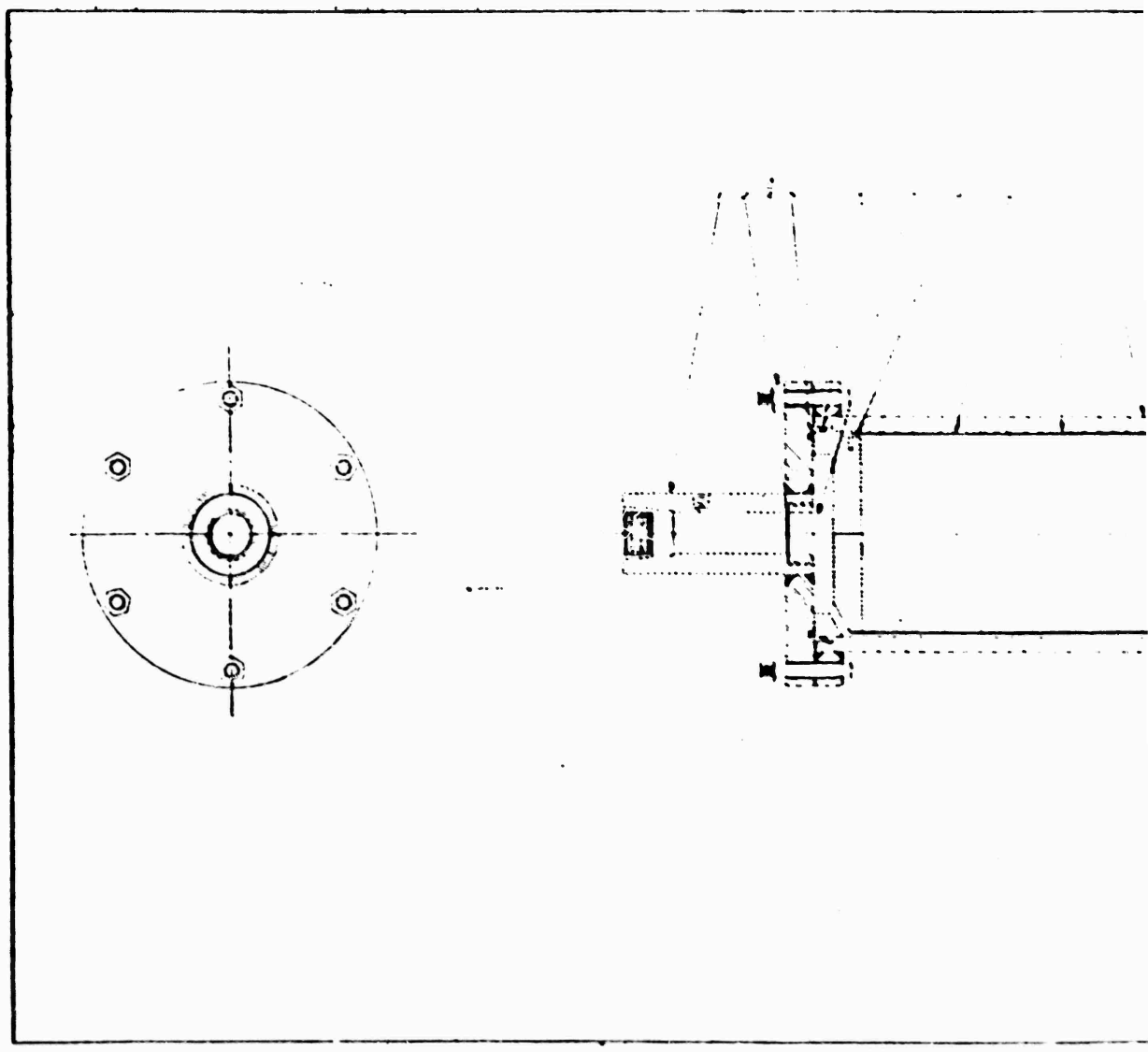

/

L

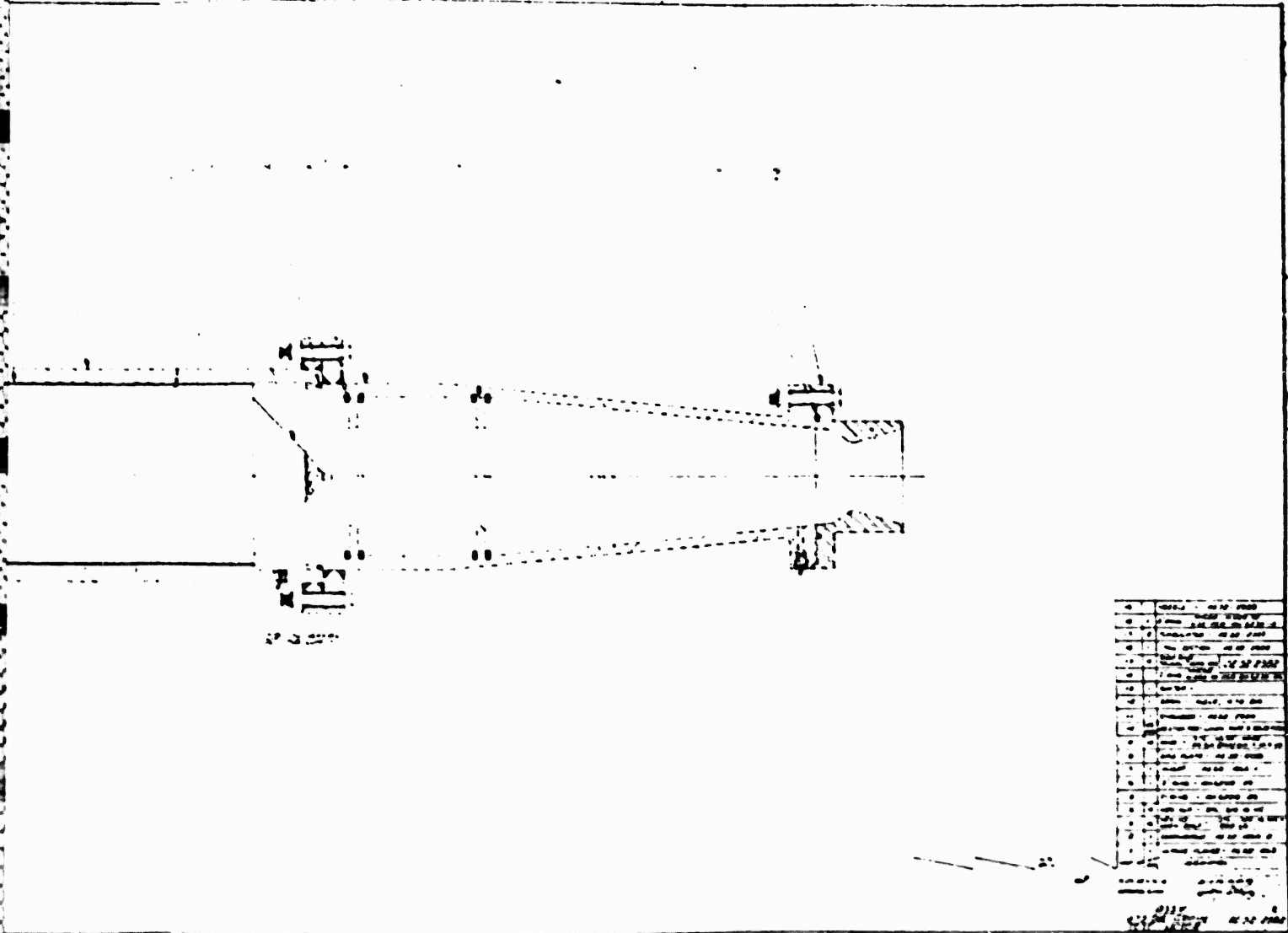

2

Figure 5

CONFIDENTIAL

CONFIDENTIAL

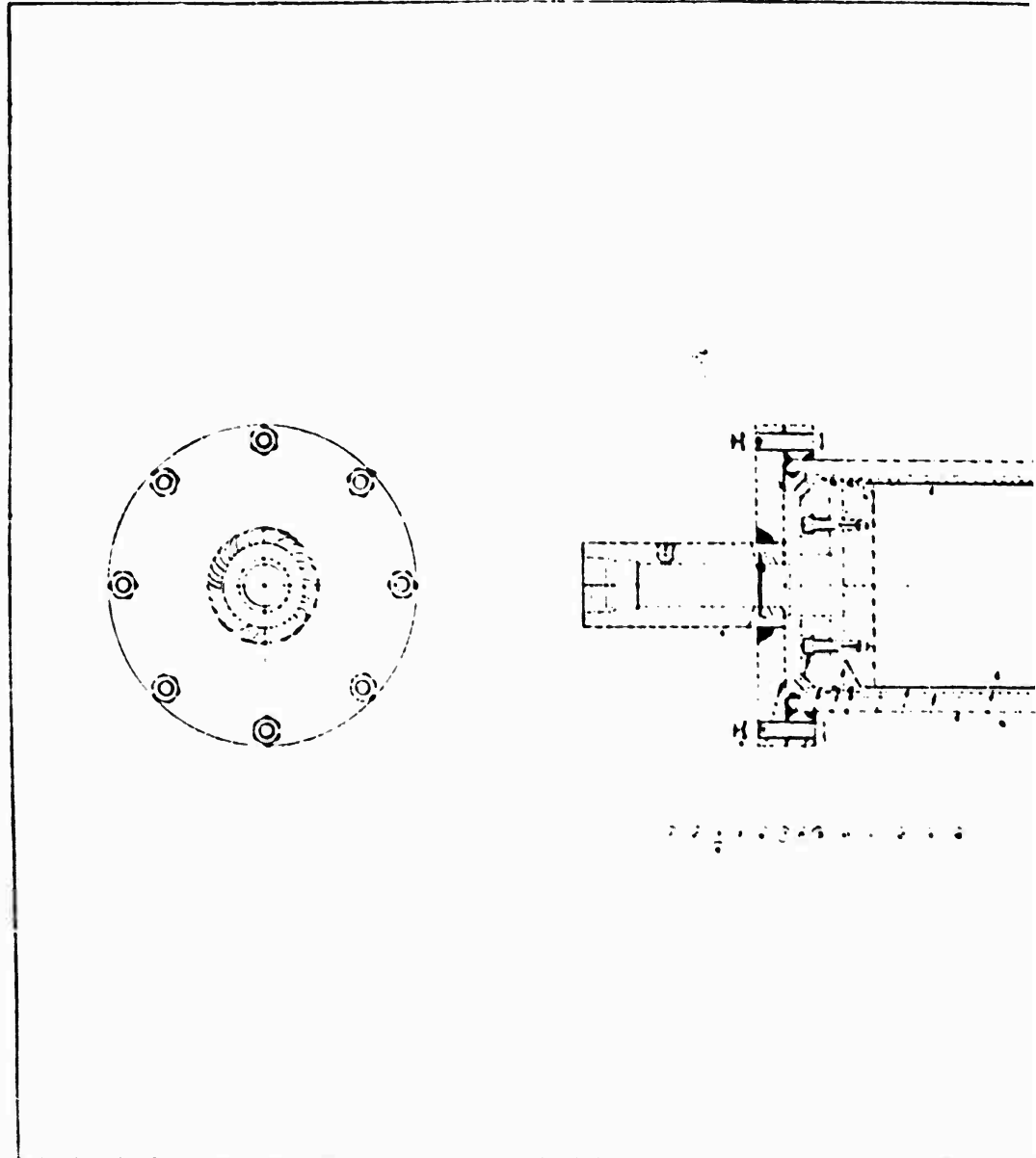

LO

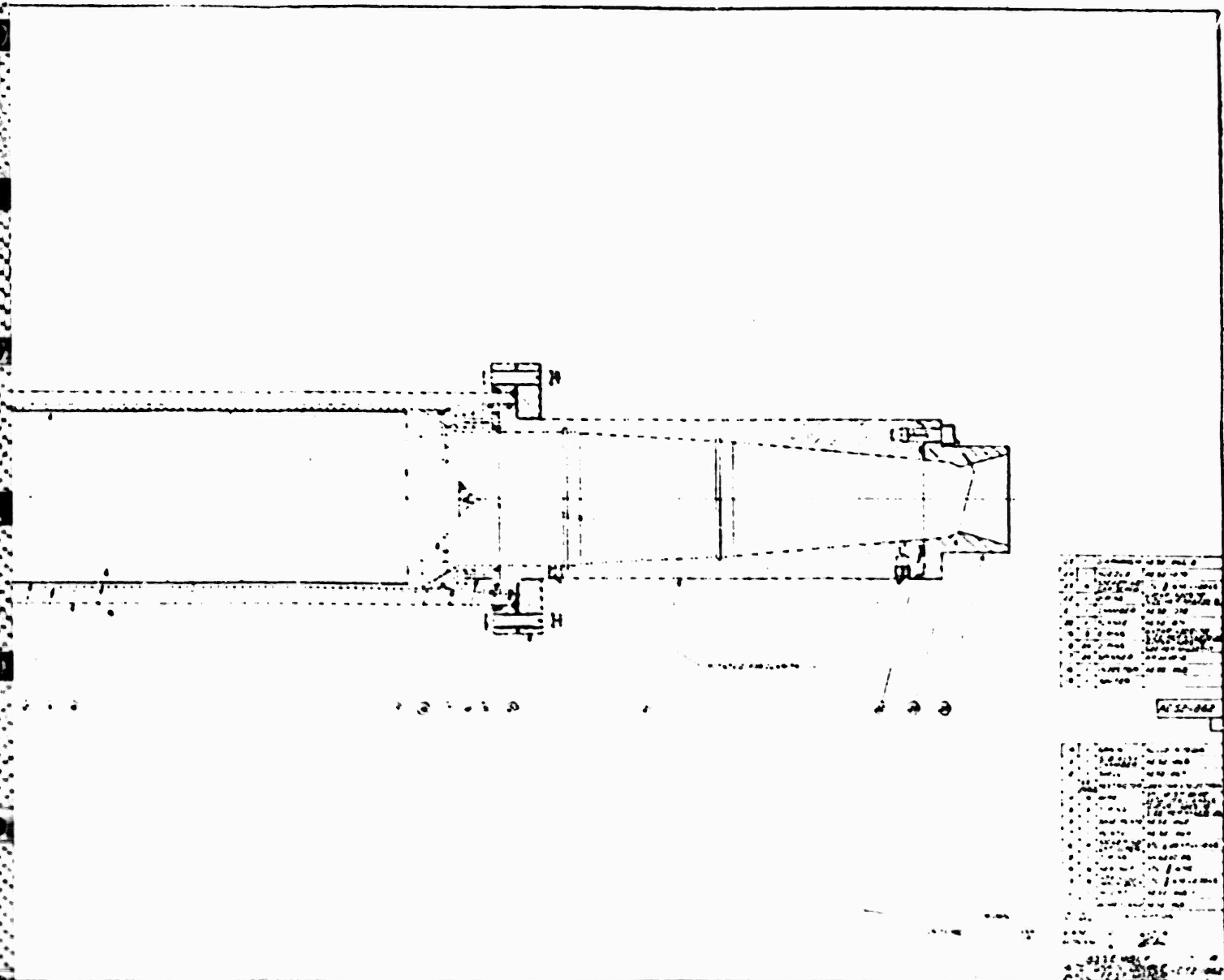
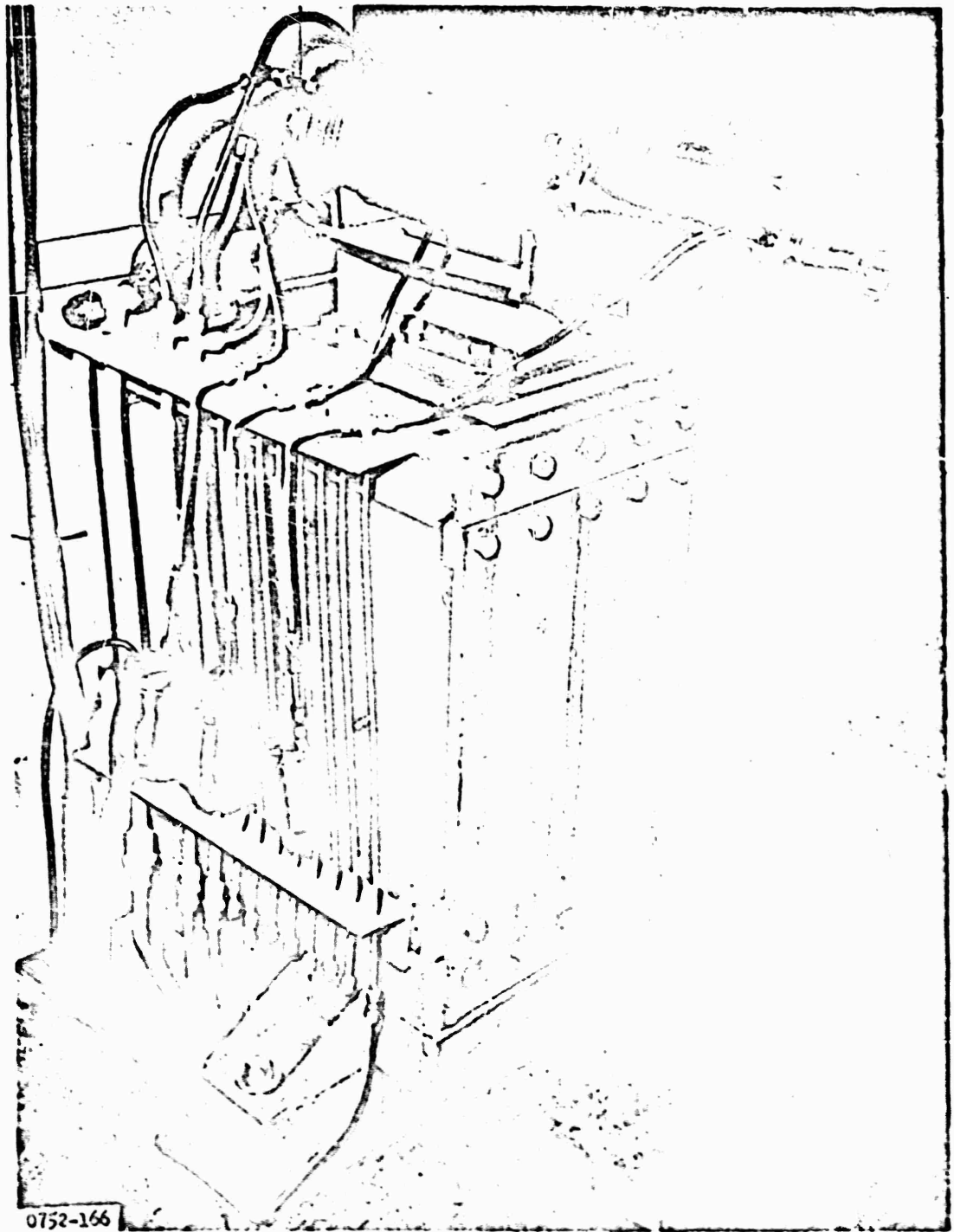

Figure 6

CONFIDENTIAL

(2)

1



Alco Motor Setup for Testing in Static Test Pit

Figure 7

BURNING RATE CURVE  
ALCLO PROPELLANT

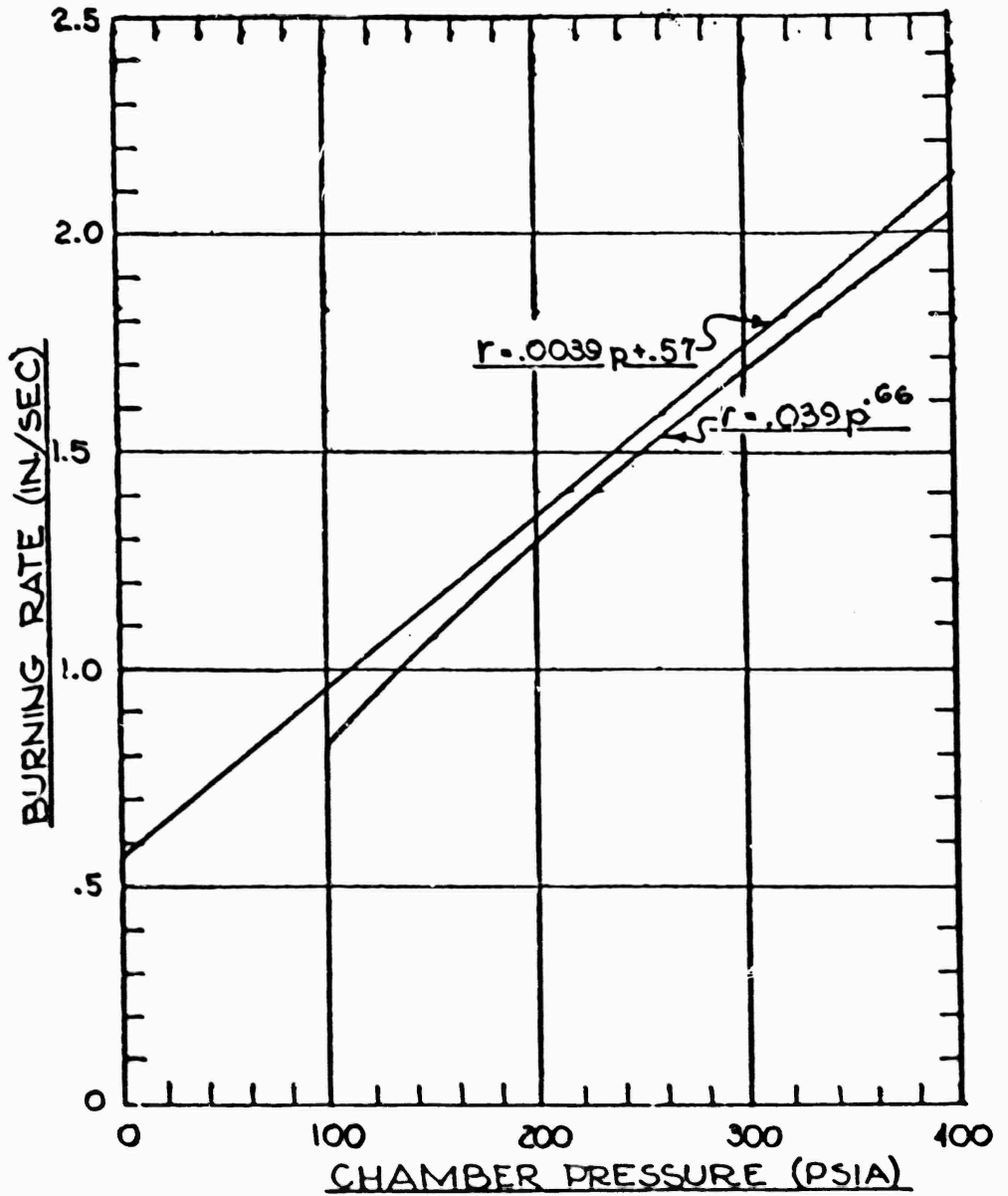

C-4220

Figure 8

S - NO. 10348 6-23-52 BW.

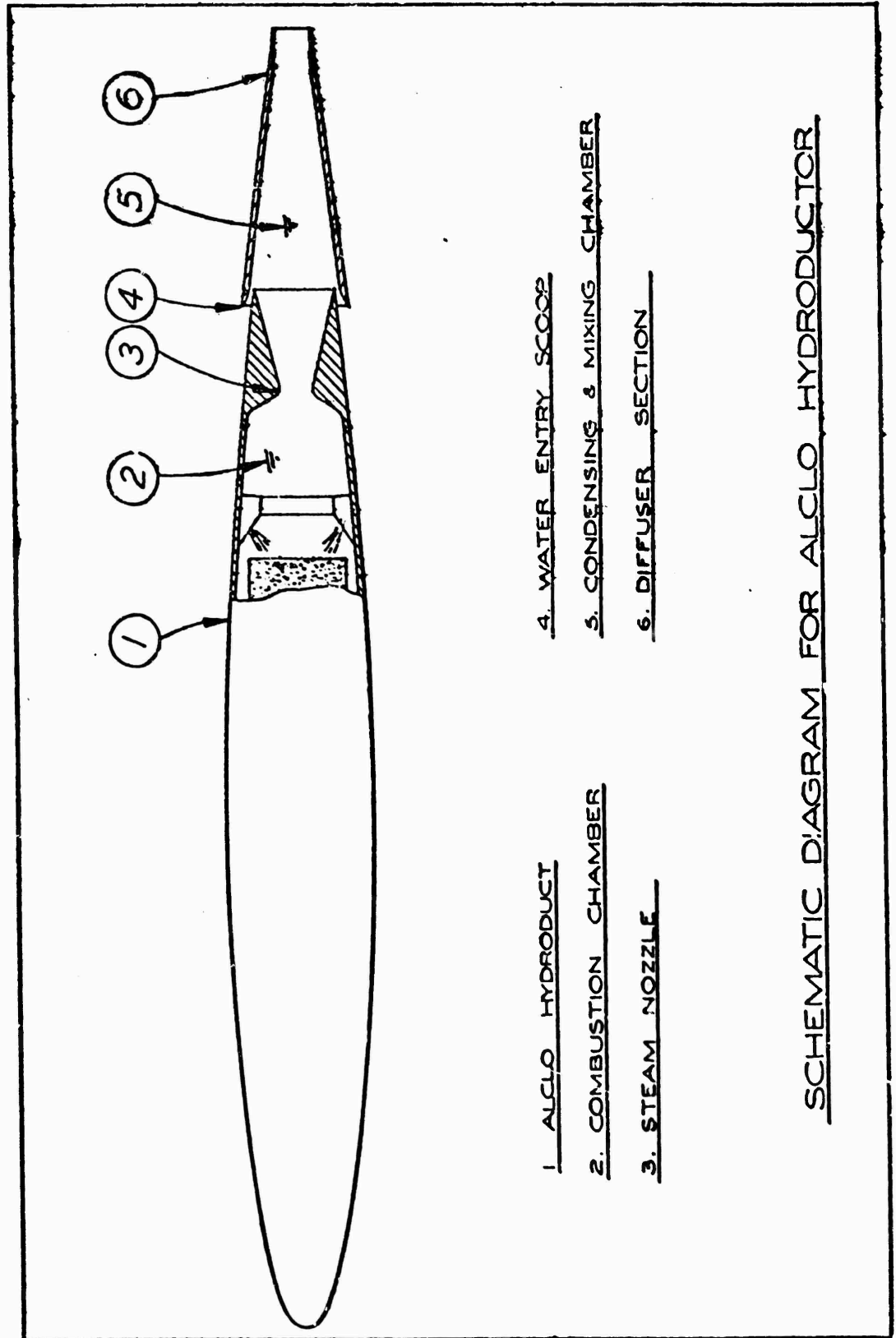

SCHEMATIC DIAGRAM FOR ALCLO HYDRODUCTOR

CONFIDENTIAL

Report No. 725

C-4148

BW/EH 12-22-52

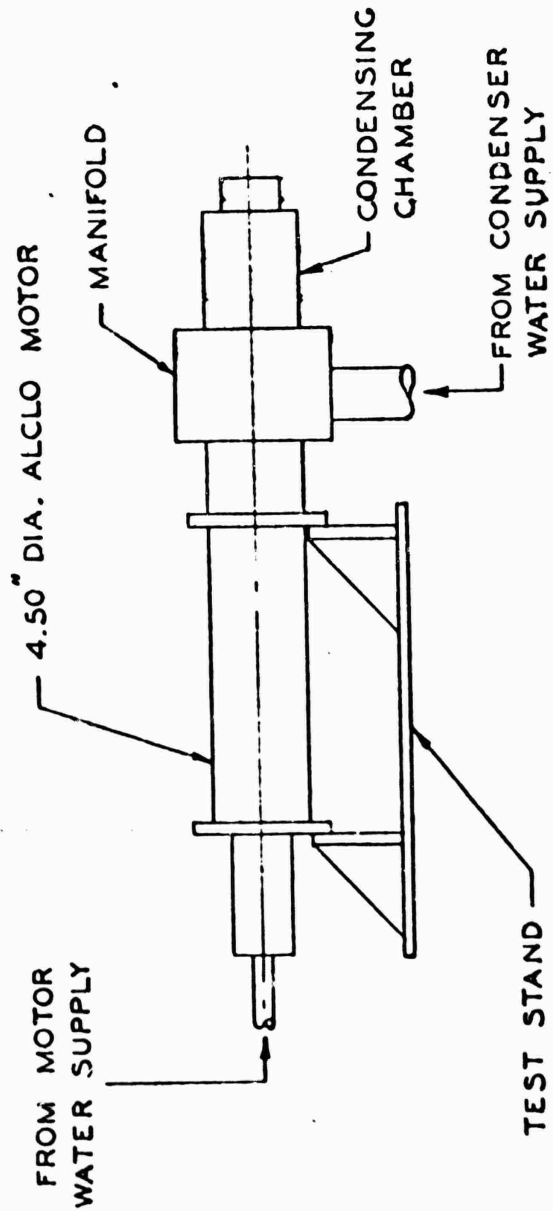

TEST INSTALLATION FOR PROTOTYPE STEAM-JET  
CONDENSER

Figure 10

CONFIDENTIAL

C-4149 BW/EH 12-22-52

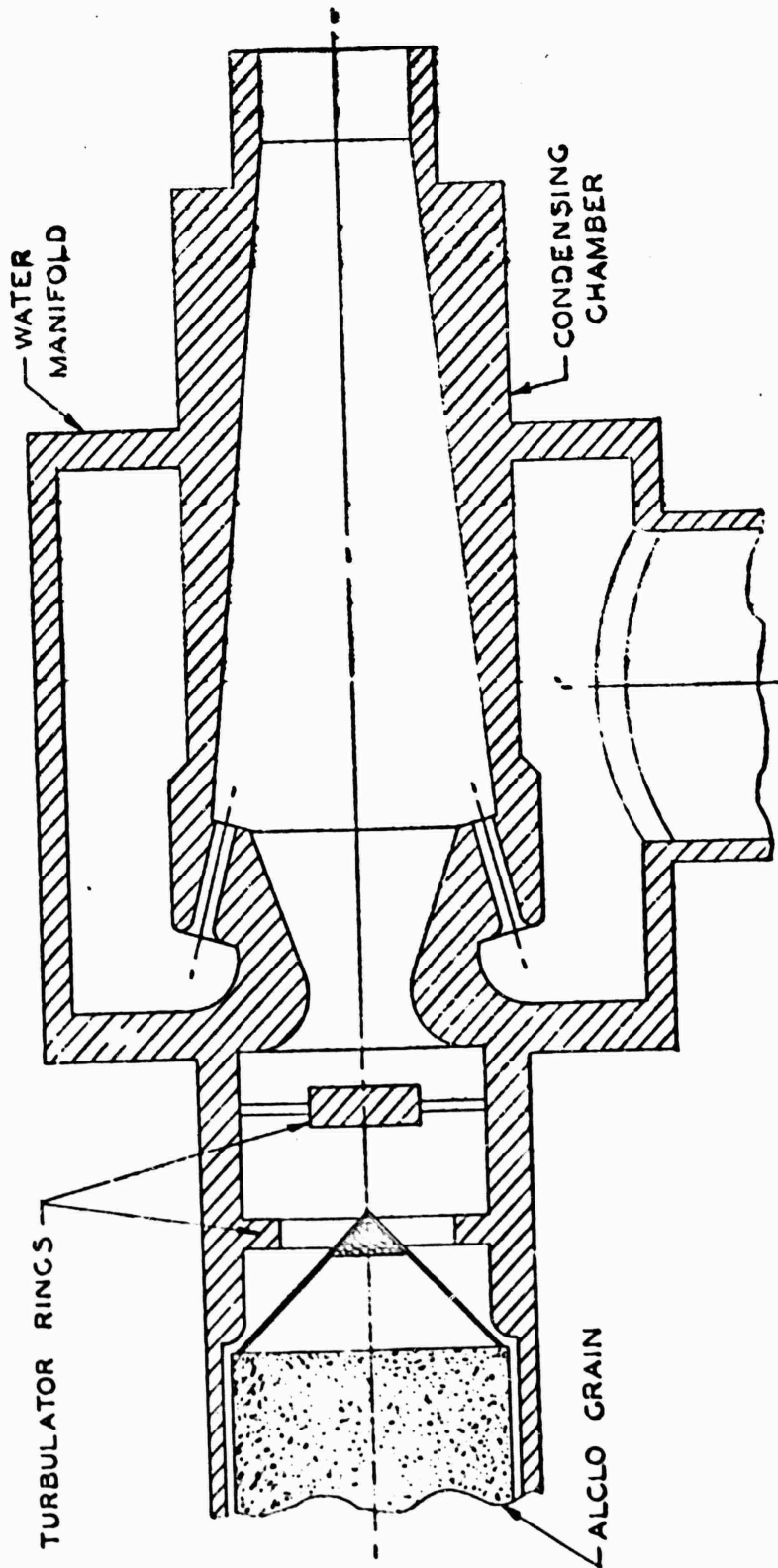

PROTOTYPE STEAM-JET CONDENSER  
TEST SET-UP

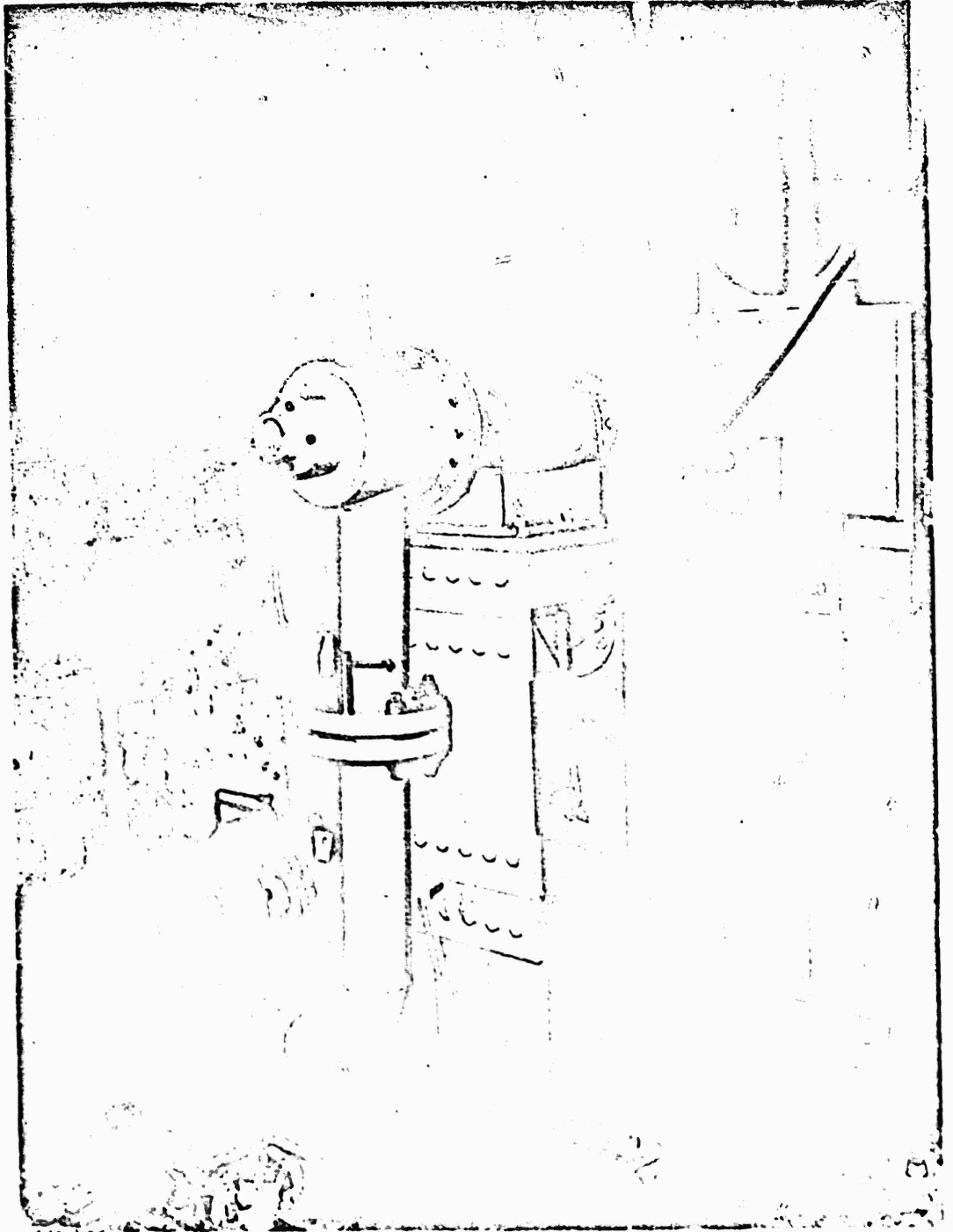

0653-1435

Hydroductor Test-Pit Setup

Figure 12

CONFIDENTIAL

Reference to the name of the  
person or organization in this document  
does not constitute an endorsement or  
approval by the Department of Defense.

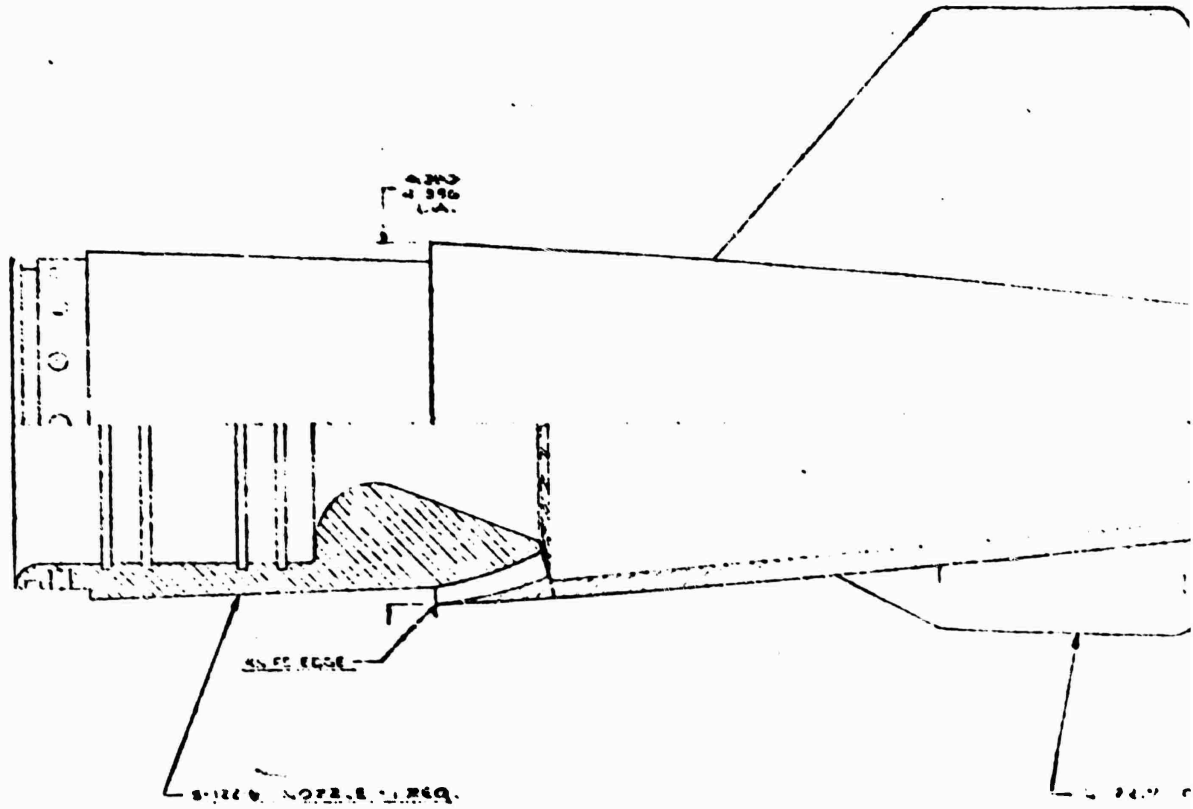

100%

L (1)



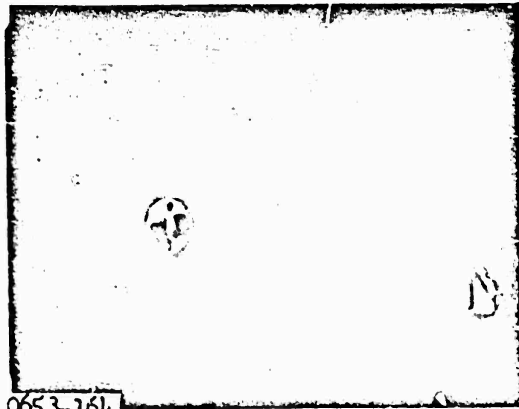

0653-164

At Ignition



0653-162

Grain Starting to Burn



0653-166

Grain Burning, no Water

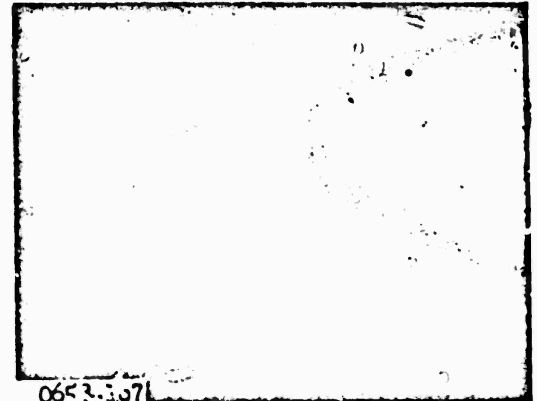

0653-167

Alclo Motor Running

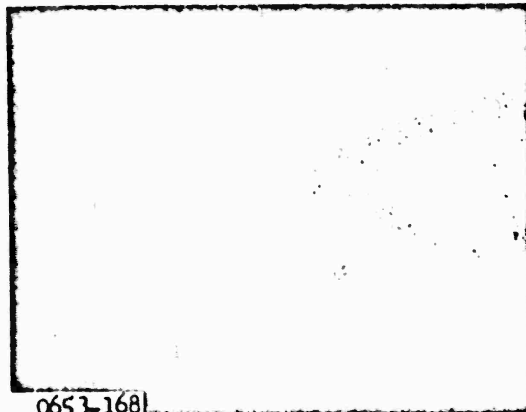

0653-168

Hydroductor Fully Condensing

Pictures from Typical Hydroductor Static Run

Figure 1h

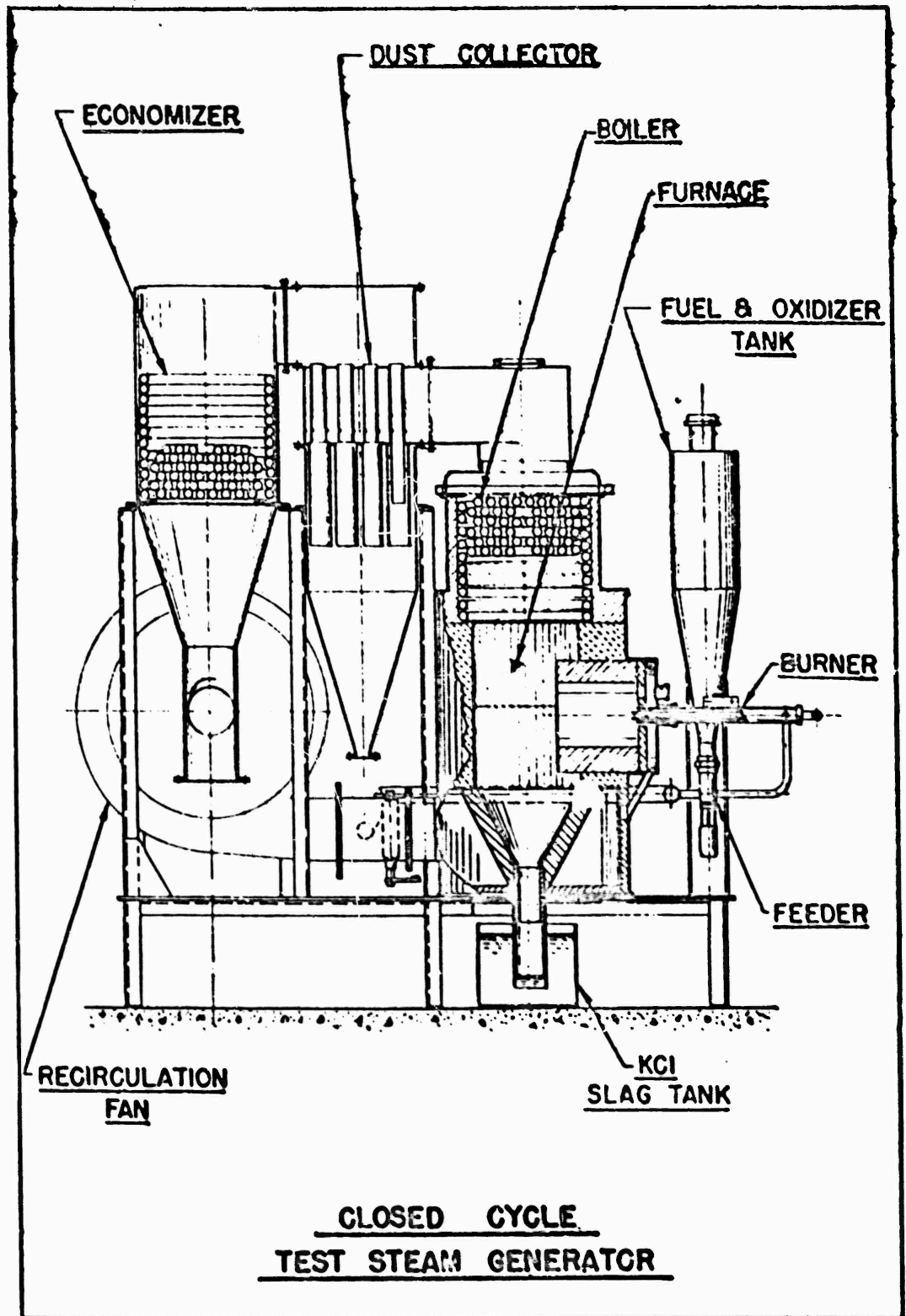

CONFIDENTIAL

Report No. 725



Test Steam Generator

1251-264

Figure 16

CONFIDENTIAL

CONFIDENTIAL

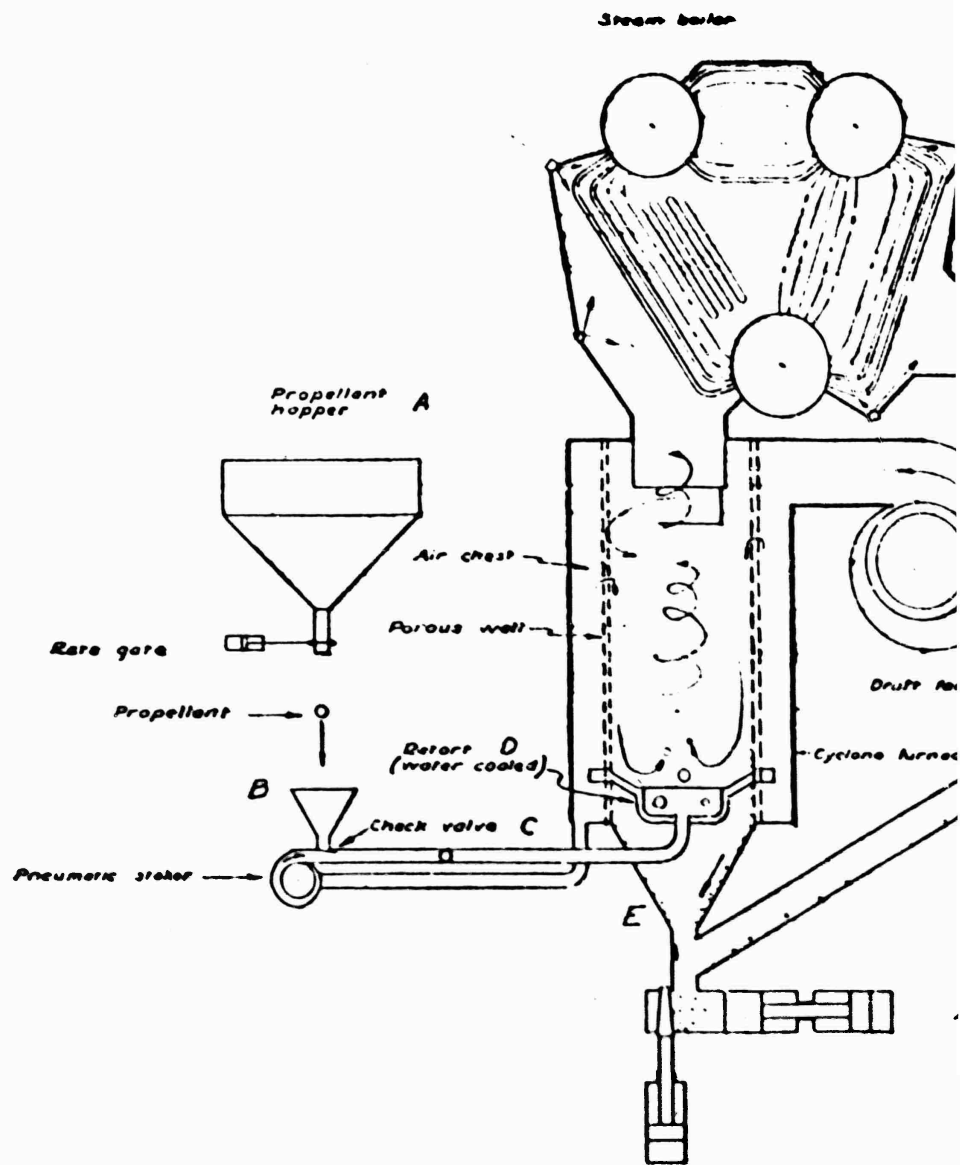
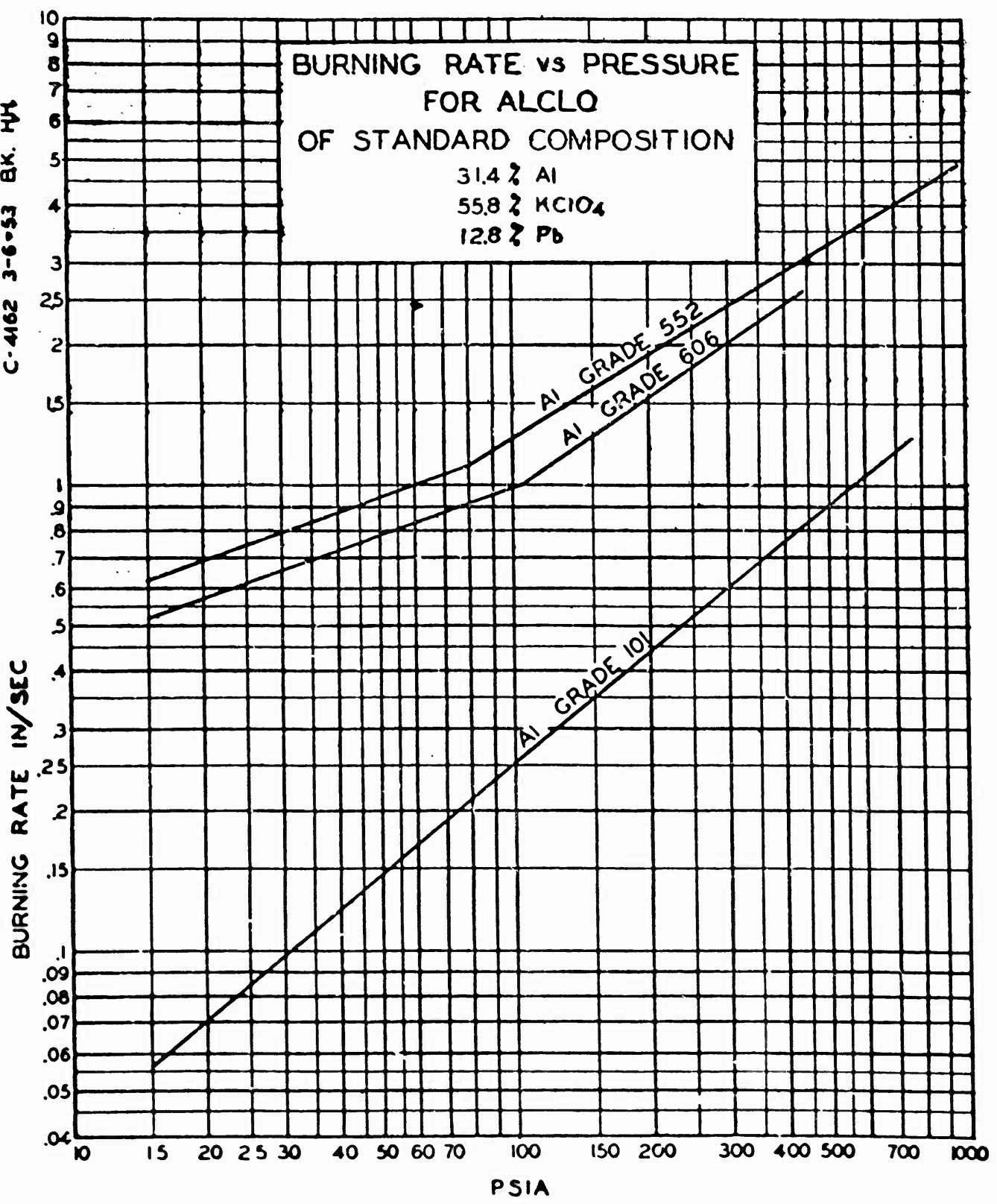

Diagram of an Alclo-Fueled Submarine Power Plant



CONFIDENTIAL

C-4162 3-6-53 BK. HH



CONFIDENTIAL

Figure 18

C-4210 7-2-53 ES/SK

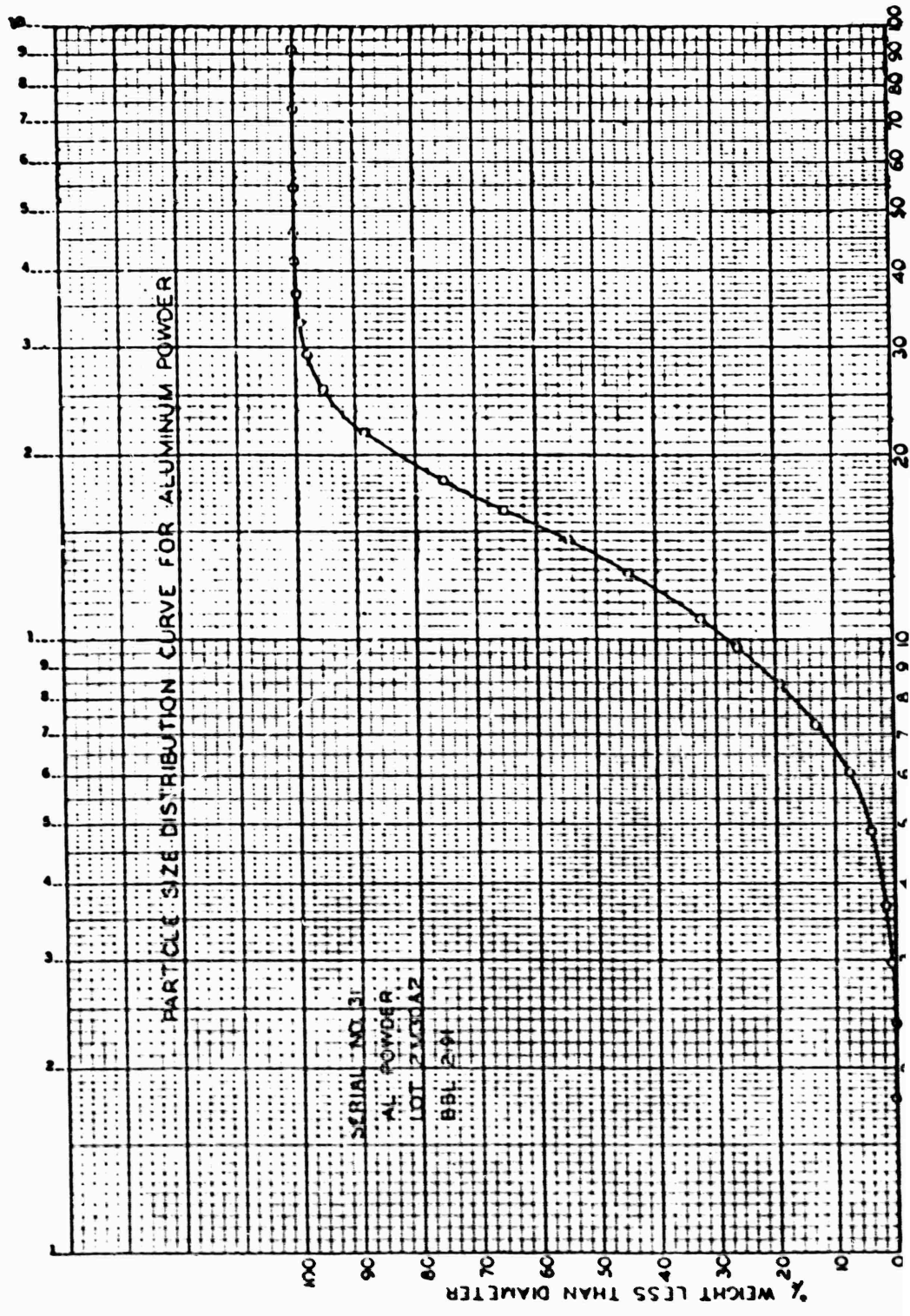

Figure

C-4221 7-6-53 ES/SK

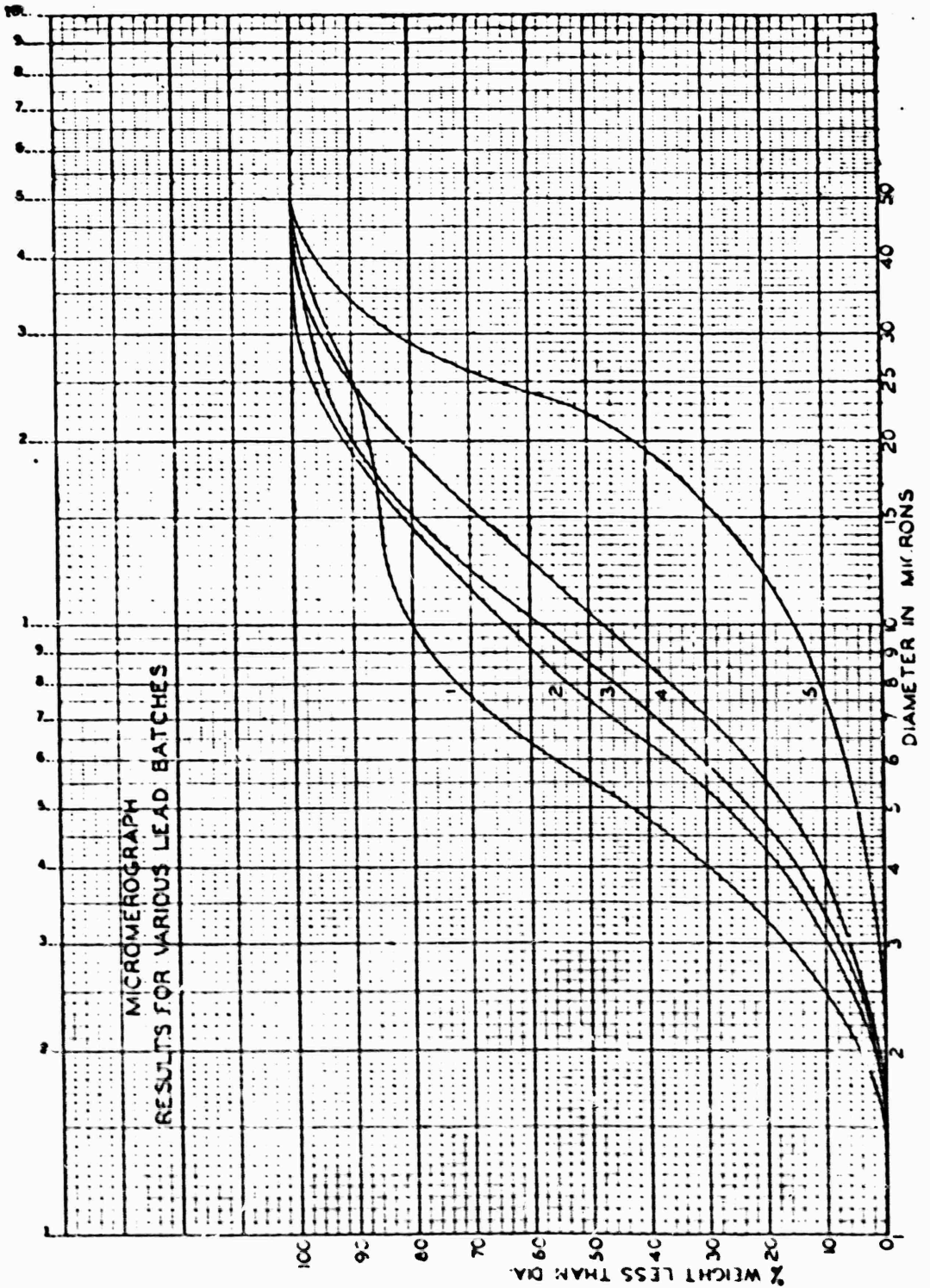

Figure 20

C-4217 7-2-53 ES/S.K.

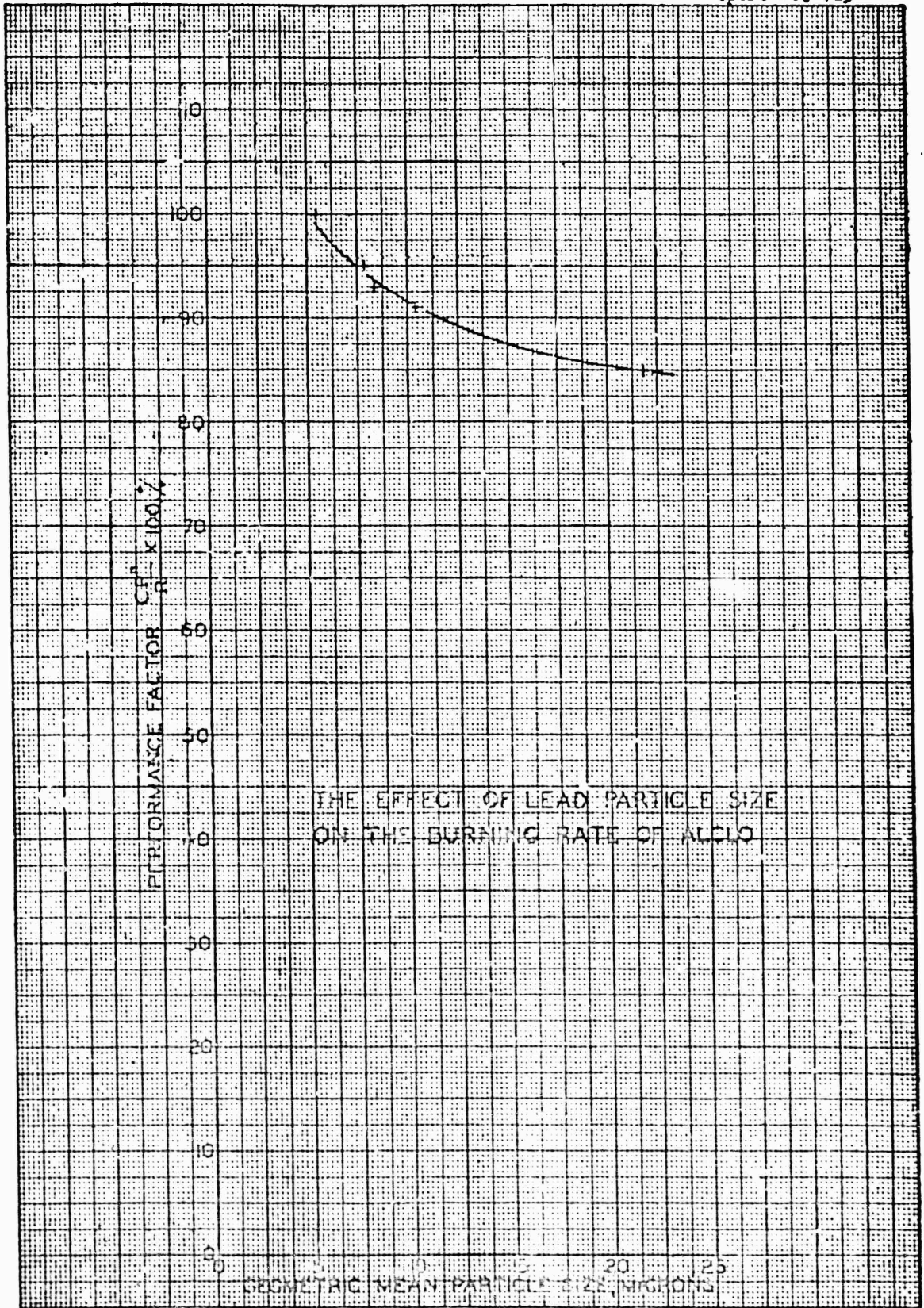
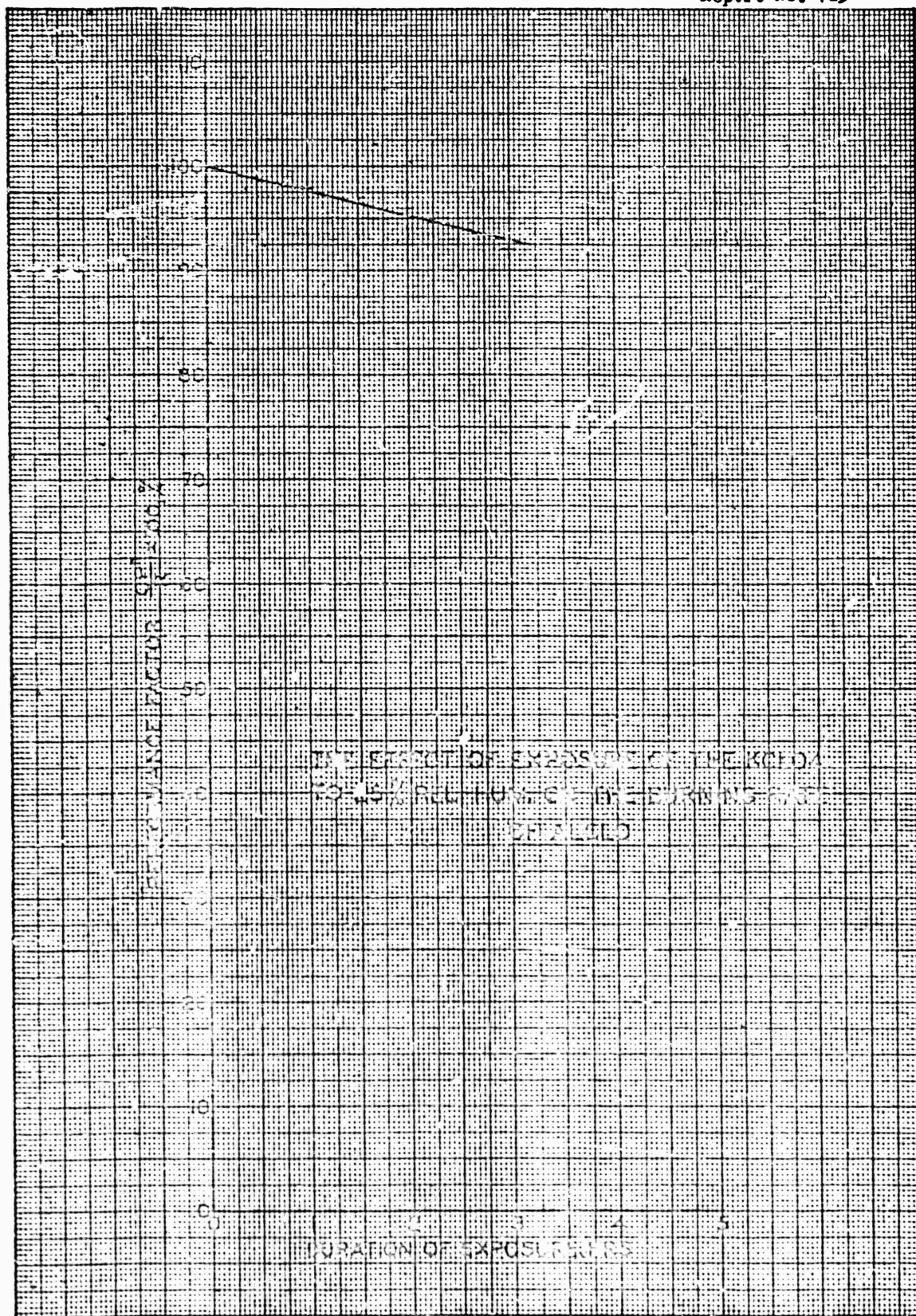

Figure 21

C-4218 7-2-53 E.S./SK.



THE EFFECT OF EXPOSURE OF THE KClO<sub>4</sub>  
TO 15% RLL TO THE PERFORMING OF  
DETAILS

Figure 22

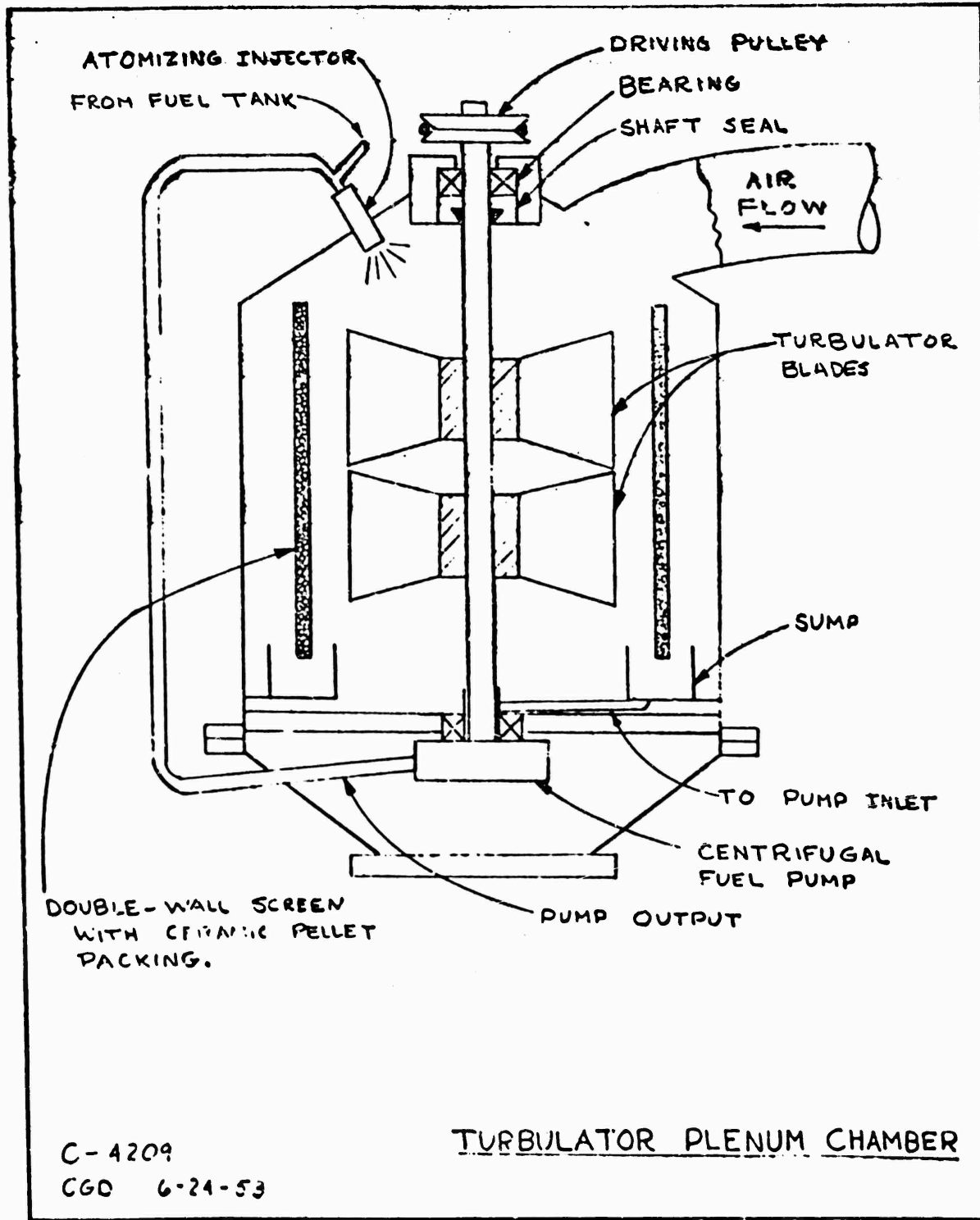
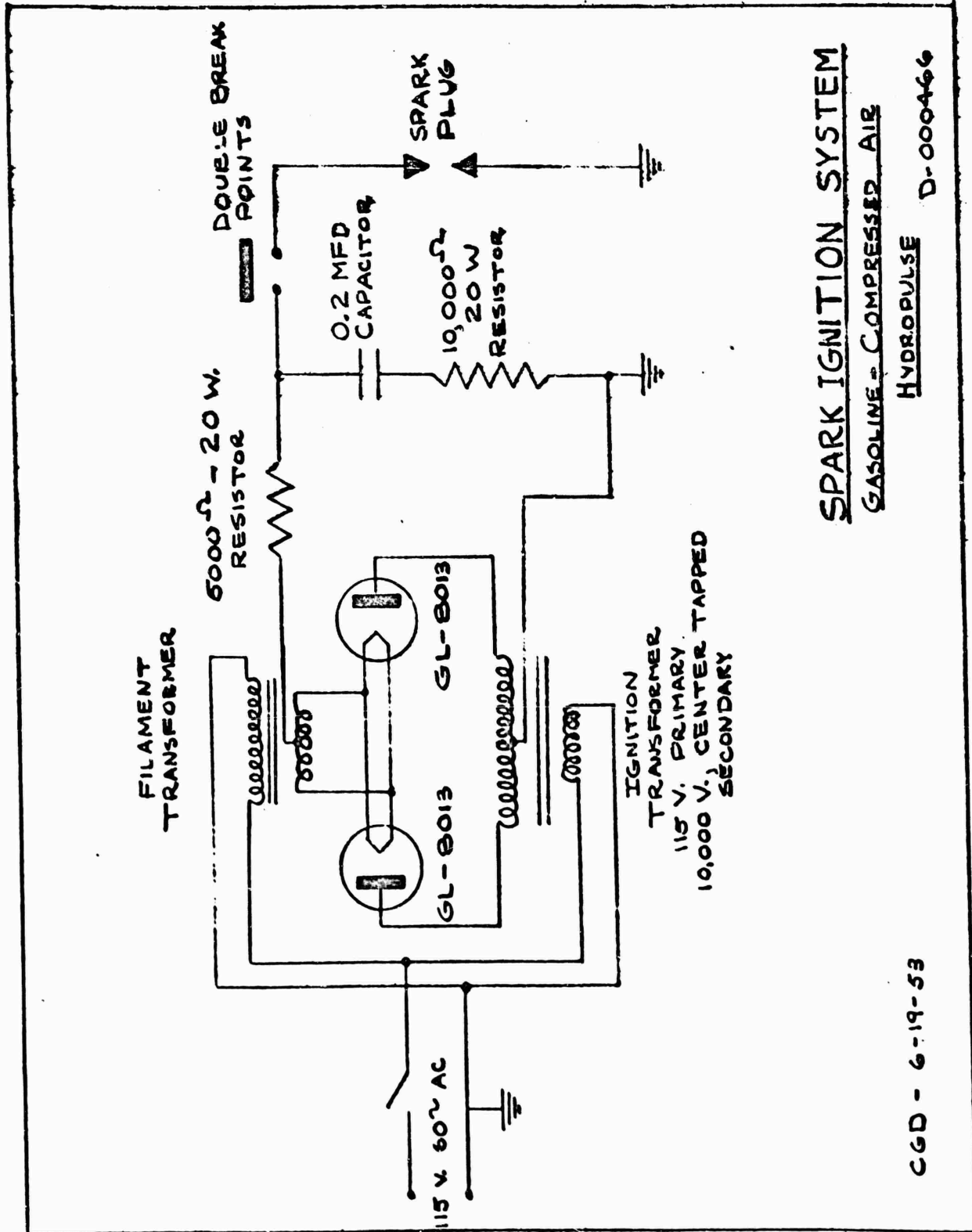

Figure 23



**SPARK IGNITION SYSTEM**  
**GASOLINE-COMPRESSED AIR**  
**HYDROPULSE** D-000466

UNCLASSIFIED

Report No. 725

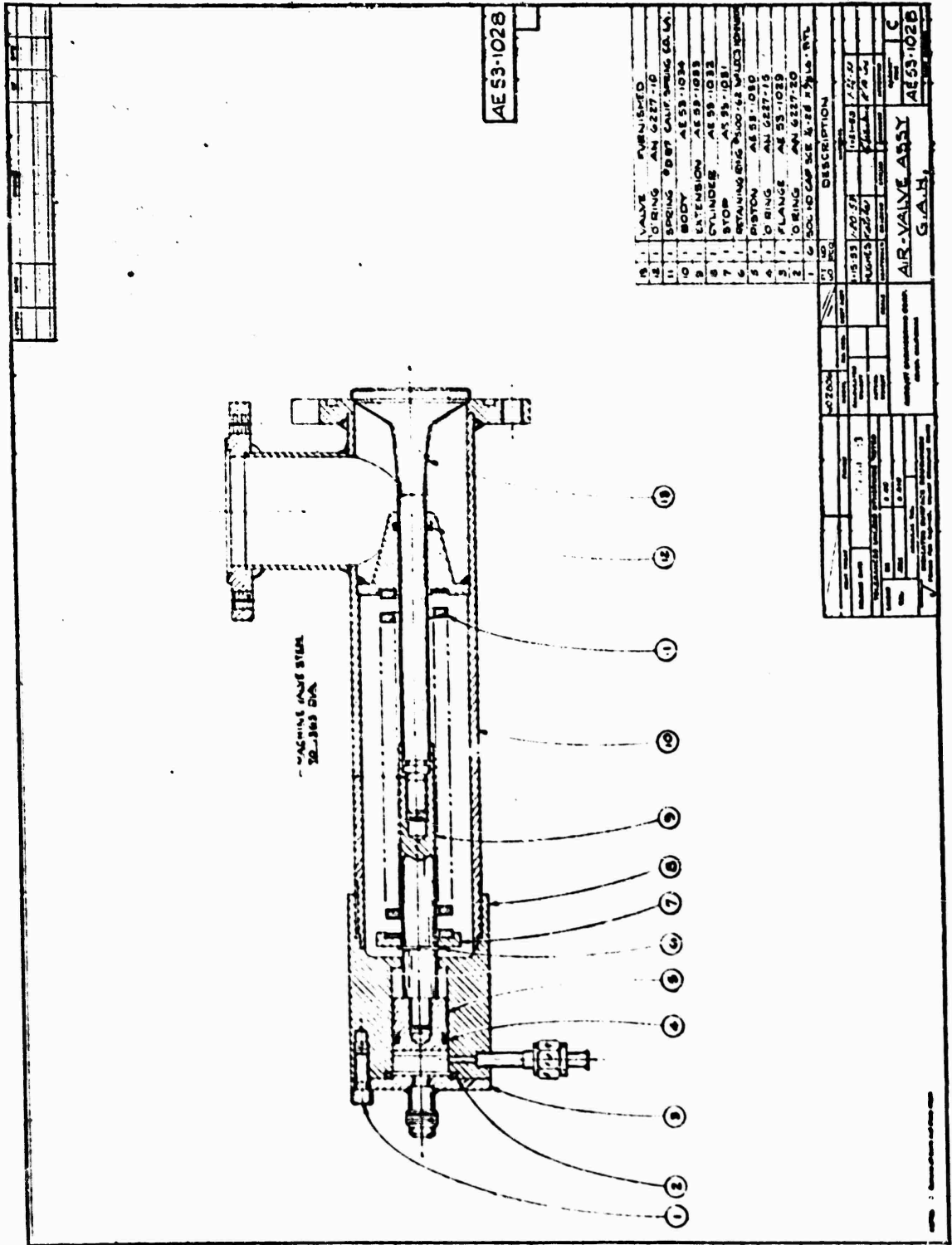

UNCLASSIFIED

Figure 25

C-4210

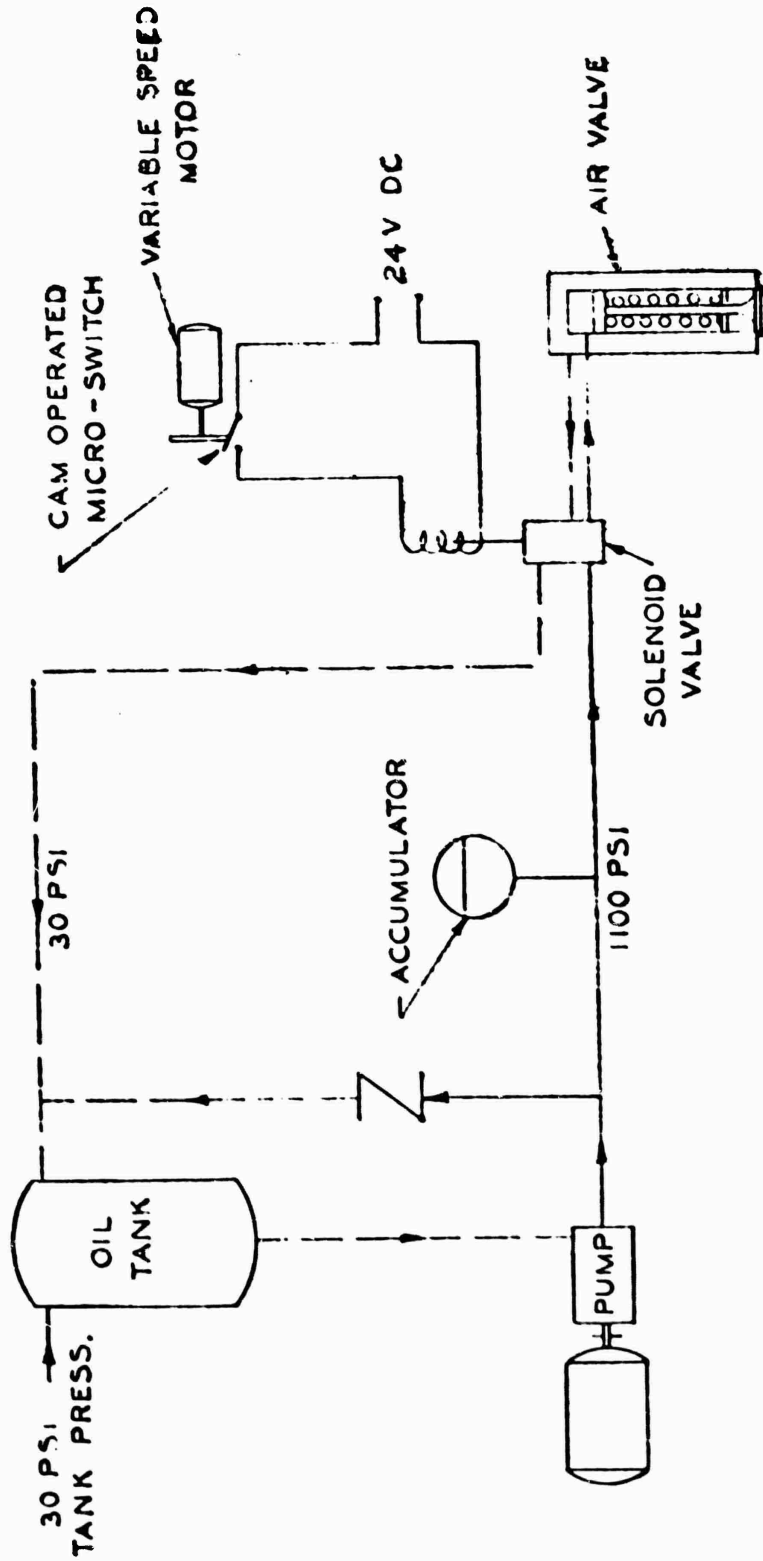

SCHEMATIC DIAGRAM  
HYDRAULIC VALVE ACTUATING SYSTEM

Figure 26

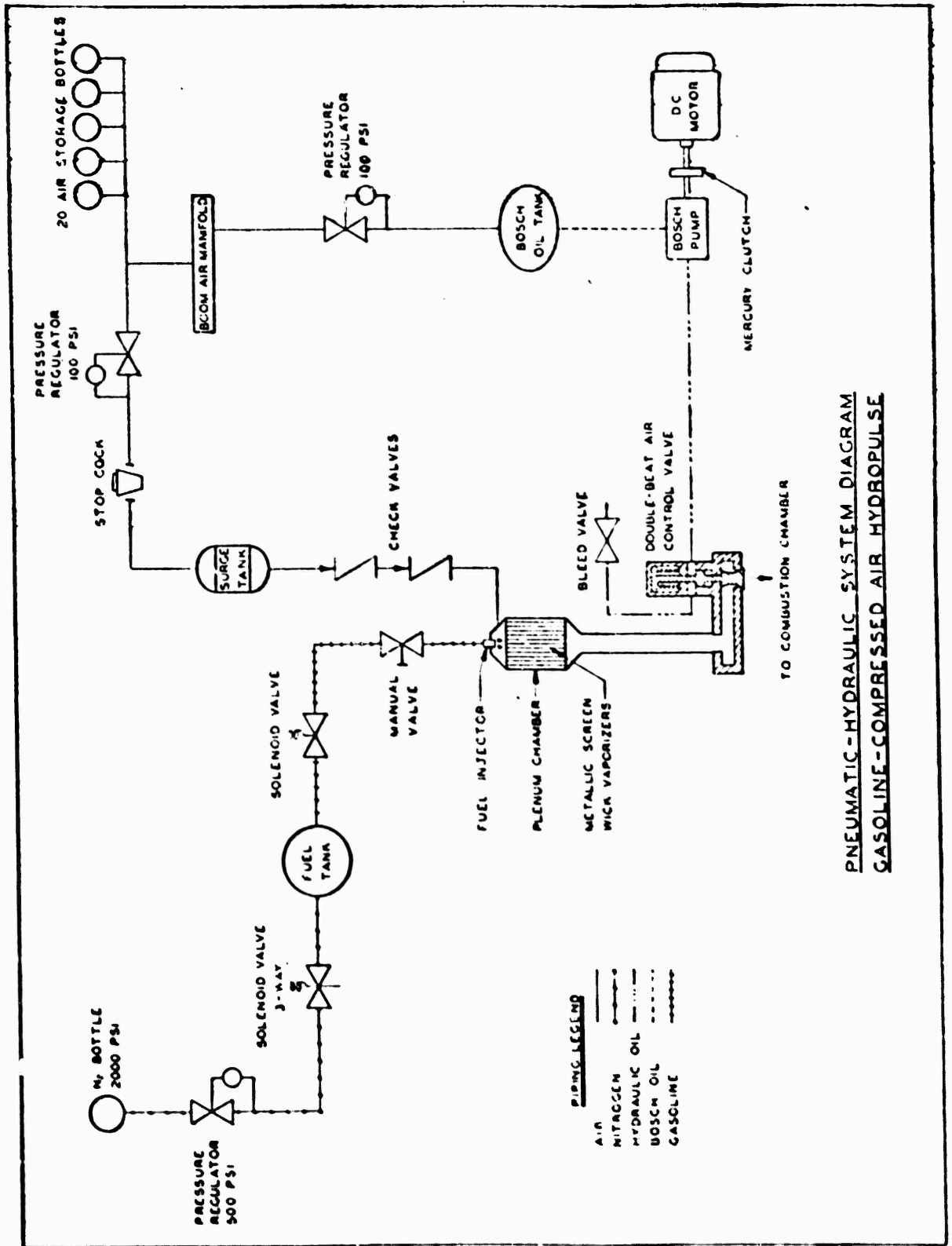

PNEUMATIC-HYDRAULIC SYSTEM DIAGRAM  
GASOLINE-COMPRESSED AIR HYDROPROPULSE

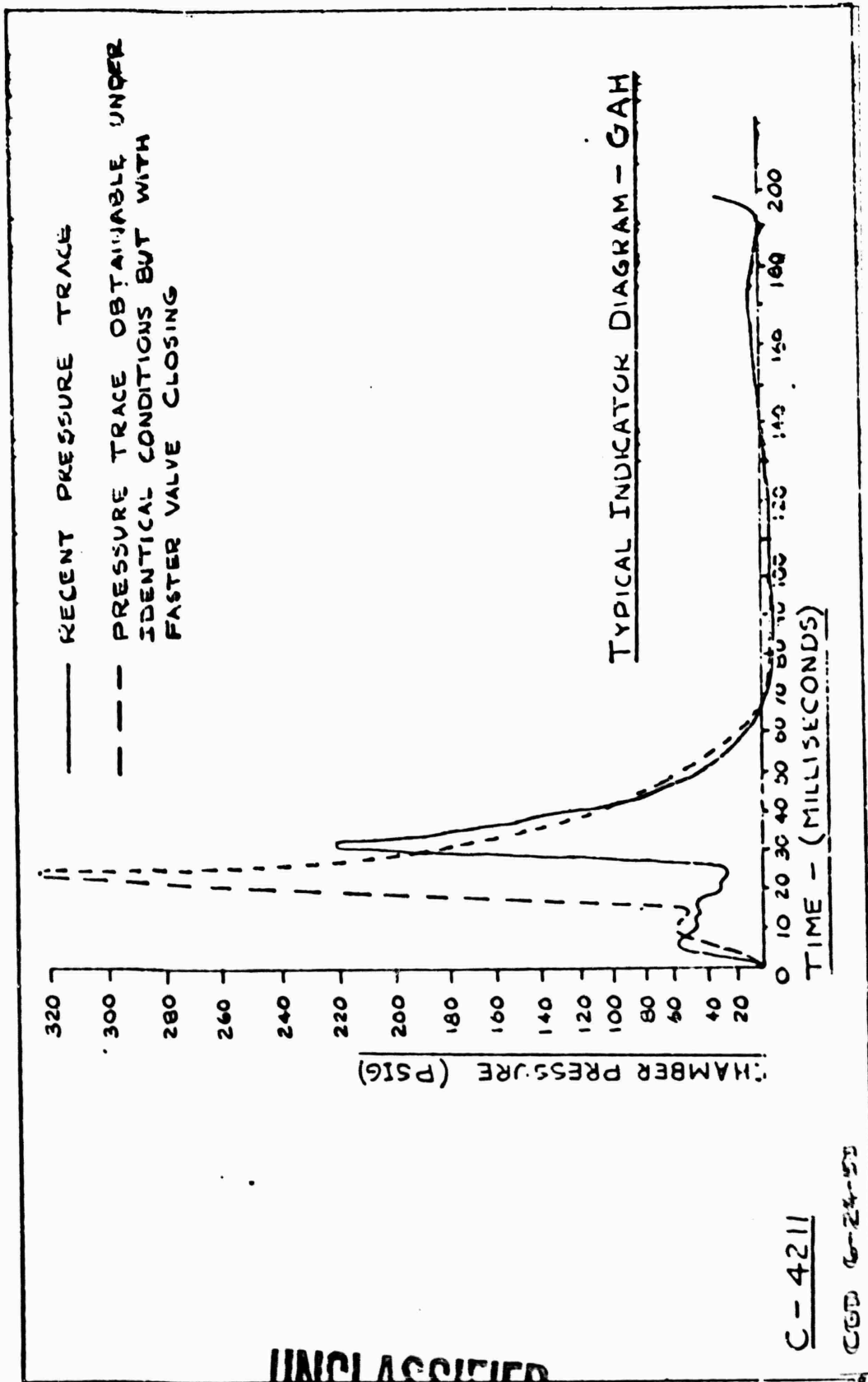

C-4211

CGD 66-24-53

Figure 8