

AD No. 20-904

ASTIA REPORT

Engineering Report No. 2. 5070 (Report No. 1)  
Project Group NT-003-016(f)

23 June 1953

**Development of Improved Methods and  
Materials for Packaging Naval Supplies**

**Manual of Cushioning Material,  
Design Criteria, and their Application**

*Prepared by*

**Forest Products Laboratory  
Madison, Wisconsin**

*As directed and coordinated by*

**SUPPLY ENGINEERING DIVISION  
U. S. NAVAL SUPPLY RESEARCH & DEVELOPMENT FACILITY  
NAVAL SUPPLY DEPOT BAYONNE, N. J.**

RESEARCH AND DEVELOPMENT DIVISION  
BUREAU OF SUPPLIES AND ACCOUNTS  
WASHINGTON, D.C.

TECHNICAL REPORT REVIEW

"DEVELOPMENT OF IMPROVED METHODS AND  
MATERIALS FOR PACKAGING NAVAL SUPPLIES"

Project No. NTO03016(f)  
Engr. Report No. 2.5070 (#1)  
23 June 1953

APPROVAL: Report approved 9 July 1953

SECURITY  
CLASSIFICATION: UNCLASSIFIED

DISTRIBUTION: In accordance with the attached approved distribution list.

REMARKS: This technical report review is inserted as the first page of the subject report as an integral part thereof.

No data, discussions or recommendations included in this research and development report or technical report review shall be construed as indicating a current or anticipated future operating policy of the Bureau of Supplies and Accounts or the Navy Department.

/s/ HERMAN STROCK  
COMMANDER, (SC), USN  
Director, Research and Development  
Division  
By direction of the Chief of Bureau

APPROVED DISTRIBUTION LIST

DEVELOPMENT OF IMPROVED METHODS AND  
MATERIALS FOR PACKAGING NAVAL SUPPLIES

Chief, Bureau of Supplies and Accounts (Code W) (5 copies)  
Department of the Navy  
Washington 25, D. C.

Chief, Bureau of Supplies and Accounts (Code S8) (5 copies)  
Department of the Navy  
Washington 25, D. C.

Officer in Charge  
U. S. Naval Supply Research and Development Facility (5 copies)  
Naval Supply Depot, Bayonne, New Jersey

One copy to each of the following:

Chief, Bureau of Ordnance  
Department of the Navy  
Washington 25, D. C.

Chief, Bureau of Ships (349)  
Department of the Navy  
Washington 25, D. C.

Chief, Bureau of Aeronautics  
Department of the Navy  
Washington 25, D. C.

Chief, Bureau of Yards and Docks  
Department of the Navy  
Washington 25, D. C.

Commandant, U.S. Marine Corps  
Division of Plans and Policies  
Research and Development Section  
Arlington Annex  
Washington 25, D. C.

Research and Development Board  
Committee on Equipment and  
Supplies  
Washington 25, D. C.

Commanding General (Code RDDQ-G)  
Air Research and Development Command  
Post Office Box 1395, Baltimore, Maryland

Chief, Research and Development Branch  
Military Planning Division  
Office of the Quartermaster General  
Department of the Army, Washington 25, D.C.

Office of the Chief of Trans-  
portation  
Department of the Army  
Washington 25, D. C.

Commanding General, Air Materiel Command  
Wright-Patterson, AFB, Dayton, Ohio  
Attn: USAF Technical Committee

Transportation Research and  
Development Station  
Fort Eustis, Virginia

Commanding General  
U. S. Army Signal Corps  
Washington 25, D. C.  
Attn: Mr. R. F. Miller

Chief of Naval Research  
c/o Navy Research Section  
Library of Congress  
Washington 25, D. C.

APPROVED DISTRIBUTION LIST (CONT.)

Office of Naval Material  
Washington 25, D. C.  
Attn: Mr. L. C. Heller

Ordnance Supply Officer  
U. S. Naval Ordnance Supply Office  
Mechanicsburg, Pennsylvania

General Stores Supply Officer  
General Stores Supply Office  
700 Robbins Avenue  
Philadelphia 11, Pennsylvania

Aviation Supply Officer  
Aviation Supply Office  
700 Robbins Avenue  
Philadelphia 11, Pennsylvania

Director  
Armed Services Technical Information Agency  
Room 648  
15th and I Sts., N. W.  
Washington, D. C.

Engineering Report No. 2.5070  
Project Group No. NTO03-016(f)

INVESTIGATION OF CUSHIONING METHODS AND MATERIALS

REPORT #1

MANUAL OF CUSHIONING MATERIALS, DESIGN CRITERIA AND THEIR APPLICATION

Supply Engineering Division  
U. S. Naval Supply Research and Development Facility  
Naval Supply Depot  
Bayonne, N. J.

ENGINEERING REPORT NO. 2.5070  
PROJECT GROUP NO. NTO03-016(f)

AUTHORIZATION:

ChBuSanda ltr file OW-3 All/3 to OinC, USNSRDF,  
Bayonne, N. J. Research and Development Project  
NTO03-016(f) Authorization No. SE52-53 dated  
9 October 1951.

PURPOSE:

To investigate the properties and characteristics  
of available cushioning materials, with the pri-  
mary aim of development of engineering design  
methods and design data to permit more economical  
and efficient cushioning of sensitive and easily  
damaged supply items.

To furnish information to be used as a basis for  
investigation into the possible development of a  
cushioning manual for Navy packaging line use  
with simplified methods and tabulated cushioning  
materials arrangement to permit application by  
packaging line personnel.

CONCLUSION:

This manual is the end product of all the work  
to date by the Forest Products Laboratory which  
has been engaged for several years in an extended  
study of cushioning methods and materials.

It is a complete instrument for the application  
of cushioning within the ranges of shock and

dimensions of materials covered. However, it must be borne in mind that the skills required in the use of the manual are not ordinarily available. The design problem is such that this procedure is economically feasible only in the case of a mass production packaging line, which usually is in the manufacturer's plant.

Therefore, it is considered that this manual is for the use of the packaging engineer, and may be furnished as an aid in procurement, so that packaging design will conform to Navy requirements for safe delivery of sensitive materials.

The report furnishes the basic material from which a simplified cushioning manual can be developed for the use of depot packaging line personnel for whom the cushioning problem is on a one-at-a-time basis. The economics involved in the supply problem must be considered in the decision to apply a given material or in the purchase of cushioning materials for stock and distribution.

RECOMMENDATIONS:

That this "cushioning manual" be considered for distribution to major contractors who may be required to package sensitive and expensive material such as electronics equipment.

That further implementation of the cushioning  
be accomplished by investigation and development  
of a simplified cushioning manual for the use  
of the packaging line in the depot for the one-  
at-a-time problem.

Containers 7-5

MANUAL OF  
CUSHIONING MATERIALS, DESIGN CRITERIA AND THEIR APPLICATION

By

R. K. PETER, Technologist

(This manual was prepared in cooperation with the Navy Department,  
Bureau of Supplies and Accounts, and the U. S. Air Force.)

PO(33-038)51-4065E, Supp. 1(52-319)

#### ACKNOWLEDGMENT

The basic cushioning data included in this report were developed by C. A. Jordan and R. H. Witting, Engineers, and were included in the proposed revision of T. O. 00-85-8, Interior Blocking, Bracing and Cushioning, prepared in cooperation with the U. S. Air Force.

## TABLE OF CONTENTS

	<u>Page No.</u>
Introduction .....	1
Functions of Cushioning Materials .....	2
Cushioning for Protection Against Shock .....	3
Cushioning Materials as Blocking and Padding .....	3
Cushioning Materials for Protection Against Abrasion ....	5
Characteristics of Cushioning Materials .....	5
Energy Absorption Capacity .....	6
Resilience .....	6
Texture, Form and Pliability .....	7
Reaction to Moisture .....	8
Dusting Characteristics .....	8
Resistance to Mold and Bacteria .....	9
Corrosiveness .....	9
Density .....	9
Article Fragility Expressed in Terms of G-Value .....	10
Design of Cushioned Packs .....	12
Selection of Cushioning Materials .....	12
Compressing the Cushion when Packing .....	13
Rubber Cushioning .....	14
Cushioning Safety Factor .....	15
Determination of Container Size to Include Cushioning ...	15
Methods, A, B and C .....	16,17
Comparison of Cushion Designs .....	17
Cushion Design for Irregular-Shaped Articles .....	19

	<u>Page No.</u>
Summary of Cushioning Design .....	19
Cushion Use on the Packaging Line .....	21
 Tables	
Ordering Data and Other Properties of Cushioning Material - Table 1	
Fragility Class Tables -- G2 through G11	
 Illustrations	
Increasing Bearing Surface of Article by Use of Fiberboard ..	Figure 1
Two Methods of Decreasing Bearing Surface of Articles by	
Use of Fiberboard .....	Figure 2
Weight per Unit Area Calculations and Packaging Design .....	Figure 3
Basic Data for "Comparison of Cushion Designs," page 17 .....	Figure 4
Cushioning of Irregular-Shaped Article .....	Figure 5

## INTRODUCTION

A primary function of package cushioning material is to minimize shock and vibration that may be transmitted to the packaged article during transportation and handling and prevent damage that may result from the package being dropped and jarred. In some instances, an article can be protected against these transportation and rough-handling hazards by using abundant quantities of any one of the numerous available cushioning materials. However, by using proper design the cost of packaging and shipping can be reduced, appreciable savings can be made in the amount of materials used and still provide adequate protection to the packaged article. To properly design the package in order to satisfy specific requirements, certain basic factors need to be known or assumed. Four of these factors are: (1) the weight per unit area of the article in contact with the cushion; (2) the fragility of the article to be packaged; (3) the severity of shocks expected during handling and shipment of the article; and (4) the physical characteristics of the cushioning material to be used. This manual includes a discussion of these factors and presents data necessary for making the proper design of cushions as well as the procedures used.

For use in design, the fragility of the article to be packaged is expressed as its g-value. Its weight is assumed to be uniformly distributed over the supporting cushion, giving a weight per unit area value which is used in design procedures discussed later. That amount of energy resulting from an impact equivalent to a 30-inch flat drop has been assumed as an arbitrary standard and the data and illustrations herein specify the

thickness of cushioning material required to protect an article from energies of that magnitude. Consideration is given to a means of preventing looseness within the pack during shipment and storage, as well as to such factors as corrosiveness, dustiness, and the effect of moisture on the cushioning properties of materials.

This manual includes two kinds of tables. One contains descriptive data to assist in procurement of the cushioning materials in addition to some of the properties of the materials, while the second is a series of tables for use with specific fragility classes of articles in which the required thicknesses of material to package for given load conditions is given.

#### Functions of Cushioning Materials

Cushioning materials are employed primarily for one or more of the following purposes:

1. To reduce the impact or vibrational forces transmitted to the packaged article during handling and transportation.
2. To block and restrict the movement of the packaged articles, or its component parts, within the shipping container.
3. To prevent abrasion of critical or finished surfaces of the packaged articles.
4. To pad projections, corners, or edges of the article, thus preventing damage to other articles, to the container, or to packaging materials employed in the container.

Some cushioning materials can be used for all of these purposes while others may be applicable for only one or two of these functions.

For example, a material which is used primarily for shock protection may at the same time serve as blocking, may prevent abrasion, or cover sharp projections of the article. Similarly, materials used primarily to prevent abrasion may also serve to reduce shock. Hence, it must be pointed out that there are no precise limits to the various functions a cushioning material may perform in a package. However, in the selection of the most appropriate material, factors such as fragility, shape, size, weight and type of article being packed, and the packaging methods used, must be considered.

#### Cushioning for Protection Against Shock

One of the most important and perhaps the most common uses of cushioning is for the protection of fragile articles against damage from shock. Frequently, to provide this protection, the fragile article or the interior container in which it is packed is completely surrounded by cushioning and, in effect, the article is floated in the cushioning material. The article in some instances may be secured to a base which in turn can be cushioned against shock. Regardless of the method employed, a primary function of the cushioning material is to reduce the shock transmitted to the article to a value that the article can withstand without impairment.

#### Cushioning Materials as Blocking and Padding

Some articles may not require cushioning for protection against shock resulting from external causes, but may require cushioning as blocking or for padding purposes within the package. The cushioning may

be needed to block one or more units or component parts of the article into a specific position within the container. Also, it may in some instances be important to secure the article by means of cushioning to prevent shifting and consequent damage to other parts within the package.

To provide adequate protection for relatively heavy articles having small surfaces, it may be necessary to increase the area of the bearing surface so as to decrease the weight per unit area on the cushioning material. Conversely, with light, fragile articles it may be necessary to reduce, or concentrate, the bearing area in order to provide a weight per unit area sufficient to compress the cushion when the package is dropped. The reason being that without compression no cushioning effect is provided.

Corrugated fiberboard in the form of folded or die-cut pads is frequently used for increasing the bearing area. The waddings and other cushions as well may serve the same purpose. Bearing areas may be decreased by strategic location of supporting pads smaller in total area than the surface protected. Methods of increasing and decreasing the bearing area are shown in figures 1 and 2.

Articles having irregular surfaces need to have projecting portions and sharp edges padded or blocked to prevent damage due to contact with other articles within the pack, to protect barrier wraps where used, and to protect the side walls of the container. For this purpose, rigid material such as fiberboard as well as the waddings and flexible wrapping materials may be used.

Cushioning Materials for Protection  
Against Abrasion

Article surfaces which may be marred by rubbing against wood blocking, strapping, container surfaces, or other articles in the container, need some form of surface protection. The use of cushioning for this purpose differs from its use for blocking and shock protection in that lesser thicknesses of material are generally required. Cushioning materials for abrasion protection are ordinarily supplied in thin sheet form, made of soft, pliable materials, often with a paper backing for strength and ease of application. Usually the soft material is placed in intimate contact with the critical surface unless the surface is also susceptible to damage by corrosion. Such surfaces will require additional protection which will be discussed in a subsequent section.

Characteristics of Cushioning Materials

Aside from cost, the following characteristics of cushioning materials will influence their selection and application in packaging:

1. Energy absorption capacity
2. Resilience
3. Texture, form and pliability
4. Reaction to moisture
5. Dusting characteristics
6. Resistance to mold and bacteria
7. Corrosiveness
8. Density

### Energy Absorption Capacity

All of the cushioning materials discussed in this manual have a capacity for absorbing energy. However, some have a much greater capacity for energy absorption than others. With all of these materials, energy absorption capacity is increased as the amount of material (thickness) is increased. Because of the different energy absorption capacities of the various materials, it may be necessary to use greater thicknesses of some materials than others in order to provide the same amount of protection. For example, it may be shown that a specific application would require a thickness of 3.5 inches of one material, 4.5 inches of another, or 6.0 inches of a third material. It may also be pointed out that for another application involving the same three materials, but with a different loading condition and a different fragility index for the packaged article, about equal thicknesses of the same three materials might be required. Therefore, by selecting the proper material to do a specific packaging job, better and more efficient utilization can be made of available materials.

### Resilience

The resilience of a cushioning material is an important physical property which may be defined as the ability of the material to recover its original size and shape after being relieved of deforming stresses. Without exception the recovery is not complete with any of the cushioning materials discussed in this manual. Some of the rubberized products and those fabricated from glass fiber approach complete recovery after deformation and are the most capable of withstanding repeated shock loads.

In contrast, there are some materials, such as some rigid foam plastics, that are capable of absorbing energy resulting from the initial shock load, but in absorbing the energy they may deteriorate, disintegrate, or become permanently deformed. The uses of such products are limited in the packaging of war materiel. The materials that are considered in this manual exhibit various degrees of resilience and are capable of regaining, at least in part, their original shape, form, and shock absorbing capacity after repeated shock loads.

#### Texture, Form and Pliability

The texture of cushioning materials may range from coarse fibrous structures and granules to soft smooth downlike fibers. The basic fibers may be bonded together into bats, sheets, castings, or blocks by the addition of adhesives, binders, sizing, or by entwinement and interweaving of the fibers. Although the basic fibers may be inherently soft and pliable the addition of the bonding material, if abrasive, may limit the uses of the material. However, some materials, such as creped cellulose wadding, cotton wadding and sponge rubber are soft textured and can be placed in direct contact with easily marred surfaces where corrosion is not a factor.

.....

The ability of a cushioning material to conform to an irregular shaped article sometimes depends upon the thickness used. Where considerable thickness is required for shock protection it may be more advantageous to use several layers of a thinner sheet rather than attempt to make a thick sheet conform. If this is not practical, a different material might be chosen.

### Reacting to Moisture

Generally, the cushioning materials included in this manual are hygroscopic, and their shock absorption capacity is influenced by moisture content. With the exception of excelsior, the shock absorption capacity of which is not noticeably affected by moisture content changes in the range of 12 to 18 percent, the hygroscopic materials are adversely affected by increases in moisture content. They have less cushioning value at high moisture content than at low moisture content. Therefore, to insure proper shock protection, hygroscopic cushioning materials should be kept as dry as practical. The cushioning materials included in this manual were conditioned and tested in a room maintained at 80° F. and 30 percent relative humidity.

Of the hygroscopic cushioning materials, some take up and hold large quantities of liquid in relation to their weight and because of this unique characteristic, special uses are made of them. Absorbent cushions are often used as protective wraps for bottled liquids. In this application the cushion provides dual protection; that of insulating the bottle against shock, and of absorbing the liquid in case the bottle breaks, thus preventing damage to the container as well as the adjacent containers in the shipment of storage stacks.

.....  

### Dusting Characteristics

Varying amounts of small particles or dust often become detached from some cushioning materials during use. Articles such as sensitive electrical equipment, gyroscopes, and optical instruments, the operational function of which may be impaired by dust particles, should be wrapped or protected by other means to prevent the entrance

of dust when cushioned in such materials. Articles which are not protected from dust during use generally need not be protected against cushion dust. Generally, with the exception of some of the rubber materials, all materials dust to some extent. The extent of dusting is somewhat dependent upon the amount of rough handling experienced by the package.

#### Resistance to Mold and Bacteria

Most of the cushioning materials support mold and bacterial growth when exposed to conditions of moderate temperatures and high humidities. Mold and bacteria on the cushioning may cause the material to deteriorate and in addition may damage the packaged article. In packages destined for humid climates, or storage under humid conditions, protection should be provided by means of vapor barriers and the use of desiccants to keep the encased cushioning material dry. The exclusion of moisture from the pack will also help to prevent corrosion of metallic components of the article.

#### Corrosiveness

Corrosion may result when cushioning materials are placed in direct contact with metal surfaces. If in intimate contact with the metal surface, hygroscopic materials will absorb and hold a concentration of moisture which in turn may cause corrosion of the metal article. It has been found that hygroscopic materials, whether neutral, basic, or acidic, cause corrosion to aluminum, copper, and iron surfaces when subjected to humid conditions. Therefore, means must be provided to isolate these cushioning materials from critical metal surfaces when high relative humidity is expected during shipment or storage.

## Density

For a specific packaging condition, it may be found that several cushioning materials require the same cushion thickness. Their densities, expressed in pounds per cubic foot, however, may vary greatly and provide a logical means of selecting the appropriate one. For certain shipping conditions such as air shipment, this factor may be an important consideration.

## Article Fragility Expressed in Terms of a G-value

G-values are used in this manual as an index of fragility of the article being packed. Rugged articles have high g-values and fragile articles have low g-values. For example, an article having a g-value of 200 is twice as rugged, or one-half as fragile, as an article having a g-value of 100.

The g-value or fragility factor of an article as used in this manual is defined as the ratio of the maximum acceleration the article can withstand without impairment to the acceleration due to gravity, thus

$$G = \frac{a}{g}$$

where  $a$  = maximum permissible acceleration of article without damage  
in foot-second units

$g$  = acceleration due to gravity, 32 feet per second per second

$G$  = ratio of  $a$  to  $g$  or g-value, or fragility factor.

Therefore, if an article could withstand without damage an acceleration of 6,400 ft./sec.<sup>2</sup>, it would have a g-value or fragility factor of 200. The acceleration, 6,400 ft./sec.<sup>2</sup>, could also be expressed as 200 g.

It may also be shown that for a rigid object the g-value, G, expresses the ratio of the maximum dynamic shock load, to which an article may be subjected without damage, to the static load due to its own weight, thus

$$G = \frac{F}{W}$$

where W = weight of article in pounds

F = maximum safe dynamic force in pounds

and G = g-value

Therefore, if an article weighing 2 pounds has a g-value of 100, it may be subjected to a dynamic shock load of 200 pounds without damage.

At present the g-value for various articles are not generally available. A possible method of determining g-values, however, is by destructive tests of the article, recording the magnitude of the impact or shock which causes the article to break or become impaired. In other words, the g-value of an article, when given, is a measure of the ability of the most fragile part of the article to withstand shock.

Further, some articles are capable of withstanding greater shock forces in one direction than another. For instance, a shaft in a recording instrument may be more susceptible to displacement by shock perpendicular to a long axis than by shock forces parallel to the long axis. Therefore, the g-value for the various planes of impact should be known so that the most efficient cushioning design can be employed.

### Design of Cushioned Packs

To actually design a cushioned pack for any specific article, the fragility or g-value must be known as well as the weight per unit area in pounds per square inch for each surface of that article (fig. 3). Further, the amount of energy to be absorbed by the cushion during rough handling must also be determined. The energy to be absorbed by the cushioning material represents the difference between the total amount of energy resulting from the rough handling encountered and the amount that the article can be subjected to without impairment. The cushioning data in this manual are based on an assumed drop height of 30 inches. Besides the energy-absorbing properties of cushioning materials, other factors such as corrosiveness and whether or not the cushioning properties are changed by low temperature must be considered.

#### Selection of Cushioning Material

After determining the requirements, selection of the proper cushioning can be made by using Table No. 1 (Ordering Data and Other Properties) and the proper Fragility Class Table. The Fragility Class Table lists the materials in accordance with the nominal and compressed thicknesses required for the various article weight classes. Generally, the selection will be a material that will satisfy the requirements with the least thickness of those materials available. However, various other factors, such as cost of material, weight, cubage, freight rates, etc., should be considered at the same time.

### Compressing the Cushion When Packing

As previously stated, after some cushioning materials have been compressed, they do not necessarily recover to their original thickness. Therefore, to minimize excessive looseness within the pack during shipment or storage, these materials require certain degrees of compression at the time of packing. The extent of compression depends upon load conditions. For this reason, the compressed thickness as well as the original thickness of the cushion is shown on the Fragility Class Tables. Some of the compressed thicknesses can be attained by hand compression, others cannot.

The amount of hand compression attainable for each cushioning material is shown as a percent value of the nominal thickness in Table No. 1. This value is only approximate because the amount a cushioning material can be compressed by hand will vary with the person packing, time and care taken in packing, type of container used, size and shape of article to be packed, the thickness and shape of the cushion.

For compressed thicknesses that cannot be obtained by hand compression, mechanical means such as jigs may be used. In some instances, however, such procedures may not be practical. Further, if only a limited number of containers are to be packed, the preparation of jigs may be too costly. In other instances, the shape of the article to be cushioned may be such that jigs cannot be used. For applications where it is not practical to employ mechanical means, the alternative is to compress the cushion as much as can be accomplished by hand.

To illustrate, assume that a container is being designed for an article falling within the fragility class G-8 (150-199 F) and having a weight per unit area within the L9 range (0.45 thru 0.54 lb./sq. in.). After studying Fragility Class Table G-8 and Table No. 1, material No. 16 is selected as the most appropriate for that specific application. It may be seen in Fragility Class Table G-8 that material No. 16 for packaging code L9 requires 4 inches of cushioning compressed to 2 inches when packed. However, Table No. 1 shows that this material can be compressed by hand only approximately 30 percent. Therefore, unless jigs can be used to accomplish the compression, the 30 percent can be used as a compression requirement. Hence, the 4 inches of cushioning will be compressed to about 2-3/4 inches instead of 2 inches. In designing the proper size of container, allowance for the compressed cushion shall be made. Less compression than indicated in the Fragility Class Tables may cause slight loosening within the pack during shipment or storage but will not adversely affect the shock absorbing property of the cushion. It must be pointed out that the cushioning materials should not be compressed more than indicated in the tables.

#### Rubber Cushioning

Generally, rubber cushioning materials, when released from compression, almost completely recover to their original thickness. To prevent looseness within the pack, the cushion compression due to the dead weight of the article must be considered and the container reduced in size equal to the amount of compression.

### Cushioning Safety Factor

The cushioning data in this manual are based on the energy-absorbing properties of the cushioning materials alone. For each packaging condition in the Fragility Class Tables, a cushioning safety factor has been included and therefore no additional cushioning is deemed necessary. In addition, the shipping container in which the cushioned article is packed will absorb a portion of the energy. The amount may vary greatly depending upon the type of container used and the direction of the impact upon the container. For instance, a fiber-board container dropped on a corner may absorb a major portion of the energy by the crushing of the corner. Also, in a wood container, the racking effect of a corner or edge drop will absorb an appreciable portion of the energy. The ability of a container to absorb energy can therefore be considered an additional safety factor.

### Determination of Container Size to Include Cushioning

Three design procedures for cushioned packs are presented. In choosing the proper procedure, consideration should be given to such factors as procurement and supply, the economics involved in the efficiency in packing and shipping, and storage costs.

After a cushioned pack has been designed for a specific article, the cushioning material selected becomes an integral part of the packing design. Few cushion substitutions can be made for a given container and article without reconsidering size of container, because each cushioning material may require a different thickness for the same shock protection.

Generally, each of the three methods of designing a container of the proper size includes consideration of the article and cushion. A method of design and the procedure involved is illustrated in figure 3.

#### Method A

This method consists of the use of a single material, the thickness of which may be different for each face of the article. The cushion thickness for each face is dependent upon the fragility and weight per unit area applicable to that face. On the basis of efficient cushion use, this method is a compromise between the other two methods to be described. It is suggested that the cushioning instructions for this method of design be in detail, naming the cushioning material to be used and the cushion thicknesses needed for each face of the article.

#### Method B

The Method B design is a simplified form of Method A. It differs from Method A in that instead of using various thicknesses of the same cushion for the different article faces, the article is cushioned on all faces with one thickness of material, the thickness of cushioning being that required to protect the article on the side requiring the greatest thickness. Although more cushioning material than necessary is used in this procedure, it simplifies application and instructions.

Reference can be made to the Fragility Class Tables in this manual by means of a packing code explained in "Cushion Use on the Packaging Line," page 21.

### Method C

The Method C of cushioning design results in the most efficient use of cushioning materials. Several materials may be required to cushion one article, in that each surface or plane of the article is treated as a separate unit for design purposes. Generally, the thinnest material that will provide the proper protection for each surface will be selected. The cushioning instructions for this method will need to be in detail. The use of several cushioning materials requires an assured supply of the several selected materials as compared to one material for the first two methods.

### Comparison of Cushion Designs

Because of the many fluctuating economic and supply factors involved, a complete evaluation of the various methods of design is not practical for presentation in this manual. One method of evaluation can be made on the basis of container volume (cubage) comparisons for the three methods of design. Figure 4 is used as a basis for the necessary calculations. The article weighs 30 pounds and is so constructed that the fragility is different in each of three principal directions of the article.

Method A

1. Cubage of article		3.0 cu. ft.
2. Thickness of material No. 3 needed for ends (120 g) =	2.25 in.	
3. Thickness of material No. 3 needed for sides (300 g) =	0.75 in.	
4. Thickness of material No. 3 needed for top and bottom (40 g) =	3.50 in.	
5. Cubage of the cushioning material		3.0 cu. ft.
6. Total cubage of article and cushioning material		<u>6.0 cu. ft.</u>

Method B

1. Cubage of article		3.0 cu. ft.
2. Thickness of material No. 3 used for ends (120 g) = instead of 2.25 in.	3.50 in.	
3. Thickness of material No. 3 used for sides (300 g) = instead of 0.75 in.	3.50 in.	
4. Thickness of material No. 3 needed for top and bottom (40 g) =	3.50 in.	
5. Cubage of the cushioning material		6.0 cu. ft.
6. Total cubage of article and cushioning material		<u>9.0 cu. ft.</u>

Method C

1. Cubage of article		3.0 cu. ft.
2. Thickness of material No. 11 needed for ends (120 g) =	1.75 in.	
3. Thickness of material No. 2 needed for sides (300 g) =	0.50 in.	
4. Thickness of material No. 3 needed for top and bottom (40 g) =	3.50 in.	
5. Cubage of the cushioning material		2.6 cu. ft.
6. Total cubage of article and cushioning material		<u>5.6 cu. ft.</u>

The three methods of cushioning design employ significantly different amounts of material, 3.0, 6.0, and 2.6 cubic feet, to cushion the same article against the same shipping conditions. Where shipping or storage space is a critical factor, minimum cubage may be an important consideration of design.

#### Cushion Design for Irregular Shaped Articles

The cushioning of odd-shaped articles is sometimes simplified by first blocking or padding the article to more or less regular form before proceeding. This may require the use of special forms, die-cut pads, or other devices. Every article of different shape and characteristics will require individual study. An illustration of cushioning irregular shaped articles is presented in figure 5.

#### Summary of Cushioning Design

For proper cushioning design:

1. The fragility of the article to be cushioned, G, should be known. This information may be furnished by the manufacturer or determined by the user.
2. The severity of shock expected during handling and shipment of the article is arbitrarily designated. The design data in this manual (Fragility Class Tables) are based on the average energy equivalent to a 30-inch drop.
3. The weight of the article, expressed in pounds per square inch of bearing surface (weight per unit area), must be calculated for each bearing surface of the article (fig. 3).

4. Other factors such as performance under low temperature exposure, dusting characteristics of cushioning materials, and the effect of moisture content on cushioning properties, etc., should be considered when selecting a cushion. (The design data in this manual are based on cushion performance at 80° F. and 30 percent relative humidity.)

5. The cushioning material which provides the necessary shock protection with the least thickness (Fragility Class Tables G-2 to G-11) and meets the other requirements previously stated in No. 4 should be selected (Table 1).

6. The compressed thickness necessary is also shown on the Fragility Class Tables G-2 to G-11. For a specific material and packaging condition, the compressed thickness, where applicable, is listed directly under the nominal thickness in the tables.

7. A method of design must be selected (A, B, or C, page 16), and the container must be so designed to permit the use of the required amount of compressed cushioning. Some materials such as foam rubber may or may not require compression when packing depending upon cushion compression due to the dead weight of the article. Too large a container will require more material than necessary to fill the voids and too small a container will not permit the application of enough cushioning material for proper shock protection.

8. The cushioning material selected must be considered as an integral part of the design, because for a given packaging condition, the various materials may require different nominal or compressed thicknesses which in turn would influence the size of the container required.

Substitution of another cushioning material for the same article and container may be made, providing the required thickness is the same for the substitute material.

#### Cushion Use on the Packaging Line

The proper cushioning of an article on the packaging line can be accomplished only if the basic cushioning data are furnished. The instructions must include the name of the material to be used, and the thickness necessary. Also, the proper size and shape of container to accommodate the specified article with the correct compressed thickness of cushion (fig. 3) on all sides must be provided.

Depending upon the design used, cushioning instructions may necessarily have to be detailed or they may be supplied in a code which is applicable to the Fragility Class Tables in this manual. For example, a term such as G-4/L1-M16 may be used. This means that on Fragility Class Table G-4, by cross referencing packaging code L1 and material No. 16, the nominal and compressed thickness can be obtained. Therefore, it can be seen that 4 inches of material No. 16, compressed to 3-3/4 inches is necessary to cushion all faces of the article.

Table 1.--Ordering data and other properties of cushioning  
material.

(M 92787 F)  
(M 92788 F)  
(M 92789 F)

Criteria Data and Properties of Candidate Material

No.	Name of material	Manufacturer's name and address	Description	Available form	Nominal thickness	Density	Porosity	Permeability		Resistance to mold and bacteria	Remarks	
								in./min. @ 1 in. Hg.	in./min. @ 1 in. Hg.			
1			Latex foam rubber - varied colors.	a. Flat sheets b. Curved flat sheets c. Molded containers	a. 1/4 - 3/8 b. 1 - 4-1/2 c. Any size	1.3	0	0.0	0.97			
2			.....	.....	.....	0.4	0	0.0	.97			
3			.....	.....	.....	0.8	0	0.0	.97		Extra fine also available.	
4			Cotton wadding, curved homogeneous mass, surface vi-cing of starch or rosin, blue color, conforms to Federal Specification WS-C-60, Type III, Class C.	Rolls or sheets usually up to 60 inches wide.	1/4 - 3/4	1.1	.10	7.0	.98	80	Fair	
5			Cotton wadding, curved homogeneous mass, surface sizing of starch or rosin, blue color, conforms to Federal Specification WS-C-60, Type II, Class C.	.....	1/4 - 3/4	1.7	.70	7.0	.98	80	Poor	
6			Plumed wool fiber, light brown color, straight blades, conforms to Federal Specification WS-C-60, Type II, Class A.	Sheets 24, 30, 40 inches wide; 30 and 40 inches long	1/2, 3/4, 7/8, 1, 1-1/4	1.4	.30	0.5	.10	80	Good	Can be obtained with surface coating on one or both sides, dyed, laminated, or compressed.
7			Curled bag and cattle tail hair bonded with reinforced rubber or new latex, conforms to Military Specification MIL-A-790, Type III.	Sheets 48 x 72 inches; rolls 24 inches wide and 72 feet long.	1 - 3	2.0	.10	0.5	0	80	Excellent	Not also available.
8			Curled bag and cattle tail hair bonded with reinforced rubber or new latex, conforms to Military Specification MIL-A-790, Type IV.	.....	1 - 3	3.0	.10	0.5	0	60	.....	
9			Latex foam sponge rubber, cream color.	Flat sheets 24 x 112 inches.	1	0.3	0	0.0	.74		.....	
10			.....	.....	1	0.5	0	0.0	.74		.....	
11			.....	.....	1	0.8	0	0.0	.74		.....	
12			Reinforced woven wadding bleached, with or without 20, 25, or 30 strands per thousand feet hair's length, conforms to Federal Specification WS-C-60, Type I, Class 0.	Rolls - unbleached, 3 to 60 inches wide; rolls - not unbleached 2 to 60 inches, any length; sheets - any size.	1/8 - 1	4.0	.05	7.0	.95	20	Good	Also available unbleached; also available in Type II, Class 0 unbleached.
13			Reinforced messenger wrapped with 40-strand black single hair, coated on all four edges.	Rolls or sheets 24 x 112 inches to 48 x 112 inches	1/4 - 1/2	7.3	Not available	0.5	.65	80	Fair	

No.	Name of material	Manufacturer's name and address	Description	Available forms	Maximal thickness	Density (lb./cu. ft.)	Dusting	Disintegrating	pH	Acidity, (compressibility) (mainly)	Resistance to mold and bacteria	Remarks
					In.	lb./cu. ft.	Percent	Percent		Percent		
14			Cotton wadding, bleached; rolled and flat or unbleached, white or grey color.	Rolls - 5 to 40 inches wide, lengths as desired, also in 12-yard bolts.	1/8 - 1/2	2.6	0.18	6.8	0.07	70	Fair	
15			Creped wadding, white color, without backing, conforms to Federal Specification MIL-C-843, Type I, Class B.	Rolls - 5 to 60 inches wide, 285 sheets - 5 to 60 inches wide, 4 to 110 inches long.	0.15, 0.50	2.6	.12	8.1	.01	90	Open	Available in 1/8" embossed.
16			Creped wadding, brown color, without backing; conforms to Federal Specification MIL-C-843, Type III, Class B.	Rolls - 5 to 40 inches wide; sheets - 5 to 40 inches wide, 8 to 110 inches long.	0.25, 0.50	4.3	.05	6.1	.01	90	.....db.....	Not manufactured at present.
17			Creped wadding or wadding with or without kraft backing, conforms to Federal Specification MIL-C-843, Type III, Class C.	Rolls - 5 to 48 inches wide, 110 sheets - 3 to 48 inches wide, 10 to 110 inches long.	0.27, 0.97, 0.50	2.9	.08	6.1	.01	90	.....db.....	Not manufactured at present.
18			Creped wadding, longitudinally compressed, brown color, without backing; conforms to Federal Specification MIL-C-843, Type III, Class C.	Rolls - 12-5/8, 14-3/4, 16-1/4 inches wide, 145 sheets long (unpacked).	0.75	5.0	.07	6.4	.04	80	.....db.....	
19			Latex foam sponge rubber, cream color.	Sheets - 36 x 60 inches; rolls - 64 inches wide.		5.0	.15	6.4	.04	90	.....db.....	
20			.....db.....	.....db.....		6.4	0	6.7	.12		Excellent	
21			.....db.....	.....db.....		7.8	0	6.7	.12		.....db.....	
22			.....db.....	.....db.....		8.7	0	6.7	.12		.....db.....	
23			20-ply creped wadding, bleached, with 1/8" bonded white tissue backing or 40-pound white kraft backing, conforms to Federal Specification MIL-C-843, Type I, Class C.	Sheets - 24 x 36 inches.	1/4	5.9	.05	6.7, 1.0, 1.08		90	Good	
24			Curled hog and horse hair, or cat's tail bonded with natural latex or neoprene rubber; conforms to Military Specification MIL-C-7789, Type I.	Sheets - 24 x 72 inches and 48 x 72 inches, or any size or diameter as requested, 3/4".	1 or 1-1/2	1.5	.22	6.8	.10	60	Excellent	

Ordering Data and Properties of Cynolamyl Material (Continued)

No.	Name of material	Manufacturer's name and address	Description	Available forms	Medical applications	Density	Durability <sup>2</sup>	Permeability <sup>3</sup>	Resistance to mold and bacteria	Remarks		
					in.	lb./cu. in.	Days	cm.	Percent			
26			Quilted bag and horse hair, or cattle tail braid, or cotton tail braid, with natural latex or composite rubbery conformers to Military Specification MIL-C-7769, Type II.	Sheets - 24 x 72 inches and 48 x 72 inches, or any size or diameter pads as requested.	1 or 1-1/2 By special order 1/2 and 3/4.	1.7	0.20	6.8	6.10	60	Excellent	Also available Type III, MIL-C-7769.
27			Quilted bag and horse hair, or cattle tail braid, with natural latex or composite rubbery conformers to Military Specification MIL-C-7769, Type IV.	.....do..... Pads - 1-1/2 to 48 inches wide, up to 100 inches long	1 or 1-1/2 By special order 1/2 and 3/4.	2.8	.14	6.8	.10	40	.....do.....	
28			Wool casuliner in 80-pound kraft wrap conforms to Federal Specification MIL-C-813a	Pads - 1-1/2 to 48 inches wide, up to 100 inches long	1/2		Not available			20	Wool, heavy casuliner, fair	
29			Wool casuliner in 80-pound kraft wrap conforms to Federal Specification MIL-C-813a	Pads - 1-1/2 to 48 inches wide, up to 100 inches long	3/4		Not available			10	.....do.....	
30			Cotton wadding, plain, bleached, unbleached, conforms to Federal Specification MIL-C-841, Type III, Class C.	Rolls of various widths.	Distances as ordered.	2.8	.10	6.7	.07	20	Good	Also available unbleached, or bleached, kraft backing.
31			Wool fiber felt, phenolic resin bonded, with or without paper backing, conforms to Federal Specification MIL-C-845, Type II, Class B.	Rolls - 3 to 60 inches wide.	1/4, 1/2, 3/4.	2.2	.45	6.7	0	20	.....do.....	Other types and classes available.
34			Quilted Duponon (vegetable fiber bonded with natural latex conformer per square foot).	Out to size up to 80-inch wide, diameter pads as requested.	1/2, 3/4, 1, 1 1/2	2.2	.12	7.0	.10	60	Excellent	
35			Cotton wadding, certified, conforms to Federal Specification MIL-C-845, Type II, Class B.	Rolls or sheets, normally up to 60 inches wide.	1/16 - 3/4	2.9	.28	7.8	.02	60	Med.	

As specified in MIL-C-7769.  
As specified in MIL-C-7769.  
Quilting.  
Quilting.

### Fragility Class Tables

G-2 (10 g-24 g) Through G-11 (300 g-350 g)

The nominal thickness with the corresponding compressed thickness shown directly below are listed for each material and packaging condition. Where only a single value is shown, it represents the nominal thickness and compression during packaging is not necessary.

Fragility Class G-2 (10g-24g)

Material No.	Packaging Code												
	L1	L2	L3	L4	L5	L6	L7	L8	L9	L10	L11	L12	L13
	Weight per Unit Area of Article to be Packaged												
	Pounds per square inch												
	0.05 thru 0.09	0.10 thru 0.14	0.15 thru 0.19	0.20 thru 0.24	0.25 thru 0.29	0.30 thru 0.34	0.35 thru 0.39	0.40 thru 0.44	0.45 thru 0.54	0.55 thru 0.64	0.65 thru 0.84	0.85 thru 1.04	1.05 thru 1.25
	Inches												
3	5.50												
10	5.00												
27	5.00 4.50												

Material No.	Packaging Code												
	L1	L2	L3	L4	L5	L6	L7	L8	L9	L10	L11	L12	L13
	Weight per Unit Area of Article to be Packaged												
	Pounds per square inch												
	0.05 thru 0.09	0.10 thru 0.14	0.15 thru 0.19	0.20 thru 0.24	0.25 thru 0.29	0.30 thru 0.34	0.35 thru 0.39	0.40 thru 0.44	0.45 thru 0.54	0.55 thru 0.64	0.65 thru 0.84	0.85 thru 1.04	1.05 thru 1.25
	Inches												
1	5.00												
2	4.25												
3	3.50	4.25	4.75										
8	5.00 5.00												
9	5.00												
10	3.25	4.00	4.75										
11	4.50												
14	4.50 3.25	5.25 3.25											
21	3.50	5.00											
22	3.50	4.75											
23	4.50												
27	3.75 3.50	5.00 4.50											

Material No.	Packaging Code												
	L1	L2	L3	L4	L5	L6	L7	L8	L9	L10	L11	L12	L13
	Weight per Unit Area of Article to be Packaged												
	Pounds per square inch												
	0.05 thru 0.09	0.10 thru 0.14	0.15 thru 0.19	0.20 thru 0.24	0.25 thru 0.29	0.30 thru 0.34	0.35 thru 0.39	0.40 thru 0.44	0.45 thru 0.54	0.55 thru 0.64	0.65 thru 0.84	0.85 thru 1.04	1.05 thru 1.25
	Inches												
1	3.25	4.25											
2	2.25	2.50	3.75	4.25	5.00								
3	2.25	2.75	3.00	3.50	3.50	3.75	4.00	4.25	4.75	5.00			
4	4.00												
	3.00												
5	4.50												
	3.25												
7	4.25												
	4.00												
8	3.25	4.25	5.00										
	3.25	4.00	4.50										
9	2.75	3.50	4.25	5.00									
10	2.00	2.75	3.00	3.25	3.50	3.75	4.00	4.25	4.75	5.00			
11	2.00	2.25	2.75	3.00	3.50	3.75	4.00	4.50	5.00				
12	4.50												
	4.00												
14	2.50	3.25	3.50	4.00	4.50	4.75	5.00						
	1.75	2.00	2.00	2.25	2.25	2.50	2.50						
15	5.00												
	3.75												
16	4.00	5.00											
	3.75	4.25											
17	4.50												
	3.25												
19	4.00												
	3.50												

Fragility Class G-4 (500-740) (Continued)

Material No.	Packaging Code												
	L1	L2	L3	L4	L5	L6	L7	L8	L9	L10	L11	L12	L13
	Weight per Unit Area of Article to be Packaged												
	Pounds per square inch												
	0.05 thru 0.09	0.10 thru 0.14	0.15 thru 0.19	0.20 thru 0.24	0.25 thru 0.29	0.30 thru 0.34	0.35 thru 0.39	0.40 thru 0.44	0.45 thru 0.54	0.55 thru 0.64	0.65 thru 0.84	0.85 thru 1.04	1.05 thru 1.25
	Inches												
20	5.00 3.50												
21	2.25	3.00	3.75	4.25	5.00								
22	2.00	2.75	3.50	4.00	4.50	5.00							
23	2.25	3.00	3.50	3.75	4.25	4.50	5.00						
25	4.50 3.50												
26	4.25 3.75												
27	2.50 2.50	3.50 3.25	4.25 3.50	5.00 4.00									
30	4.50 3.75												
32	4.50 3.50												
35	5.00 3.75												

Material No.	Packaging Code												
	L1	L2	L3	L4	L5	L6	L7	L8	L9	L10	L11	L12	L13
	Weight per Unit Area of Article to be Packaged												
	Pounds per square inch												
	0.05 thru 0.09	0.10 thru 0.14	0.15 thru 0.19	0.20 thru 0.24	0.25 thru 0.29	0.30 thru 0.34	0.35 thru 0.39	0.40 thru 0.44	0.45 thru 0.54	0.55 thru 0.64	0.65 thru 0.84	0.85 thru 1.04	1.05 thru 1.25
	Inches												
1	2.25	3.00	3.75	4.75									
2	1.75	2.00	2.50	3.00	3.50	3.75	4.00	4.50	5.00				
3	1.75	2.00	2.50	2.50	2.75	3.00	3.00	3.25	3.50	3.75	4.25	4.50	5.00
4	2.75	3.50	4.25	4.75									
	2.25	2.50	2.50	2.75									
5	3.25	4.00	4.75										
	2.50	2.50	2.75										
6	4.00	5.00											
	3.00	3.25											
7	3.25	4.00	4.75										
	3.00	3.50	4.00										
8	2.50	3.00	3.50	4.00	4.50	5.00							
	2.50	3.00	3.25	3.50	3.75	4.00							
9	2.00	2.50	3.25	3.75	4.00	4.50	5.00						
10	1.50	2.00	2.25	2.50	2.75	3.00	3.25	3.25	3.50	4.00	4.50	5.00	
11	1.25	1.50	2.00	2.25	2.50	2.75	3.00	3.25	3.75	4.00	4.75		
12	3.25	3.75	4.25	4.75	5.00								
	2.75	3.00	3.50	3.75	3.50								
13	3.75	4.25	4.75	5.00									
	3.00	3.25	3.25	3.25									
14	2.00	2.25	2.75	3.00	3.25	3.50	3.75	3.75	4.25	4.50	5.00		
	1.50	1.50	1.75	1.75	1.75	1.75	1.75	1.75	1.75	2.00	2.00		
15	3.50	4.50											
	2.75	3.00											
16	2.75	3.50	4.00	4.50	5.00								
	2.50	3.00	3.25	3.50	3.75								
17	3.25	4.00	4.75										
	2.50	2.75	3.00										

Fragility Class G-5 (75g-99g) (Continued)

Material No.	Packaging Code												
	L1	L2	L3	L4	L5	L6	L7	L8	L9	L10	L11	L12	L13
	Weight per Unit Area of Article to be Packaged												
	Pounds per square inch												
	0.05 thru 0.09	0.10 thru 0.14	0.15 thru 0.19	0.20 thru 0.24	0.25 thru 0.29	0.30 thru 0.34	0.35 thru 0.39	0.40 thru 0.44	0.45 thru 0.54	0.55 thru 0.64	0.65 thru 0.84	0.85 thru 1.04	1.05 thru 1.25
	Inches												
18	4.50 2.50												
19	2.75 2.50	3.50 2.75	4.25 3.00	4.75 3.25									
20	3.75 2.50	5.00 2.75											
21	1.75	2.25	2.75	3.25	3.50	4.00	4.50	5.00					
22	1.50	2.00	2.50	3.00	3.25	3.75	4.00	4.50	5.00				
23	1.50	2.00	2.25	2.50	2.75	3.00	3.50	3.75	4.25	5.00			
24	5.00 3.75												
25	3.75 3.00	5.00 3.50											
26	3.50 3.00	4.50 3.75	5.00 3.75										
27	2.00 2.00	2.75 2.50	3.50 3.00	4.00 3.25	4.50 4.50	5.00 4.00							
28	4.25 3.75												
29	4.50 4.25	5.00 4.50											
30	3.00 2.50	4.00 3.00	4.50 3.25	5.00 3.50									
32	4.25 3.25												
34	4.00 3.25												
35	3.50 2.50	4.25 2.75	5.00 2.75										

Material No.	Packaging Code												
	L1	L2	L3	L4	L5	L6	L7	L8	L9	L10	L11	L12	L13
	Weight per Unit Area of Article to be Packaged												
	Pounds per square inch												
	0.05 thru 0.09	0.10 thru 0.14	0.15 thru 0.19	0.20 thru 0.24	0.25 thru 0.29	0.30 thru 0.34	0.35 thru 0.39	0.40 thru 0.44	0.45 thru 0.54	0.55 thru 0.64	0.65 thru 0.84	0.85 thru 1.04	1.05 thru 1.25
	Inches												
1	1.75	2.50	3.00	3.50	4.00	4.75							
2	1.50	1.75	2.00	2.50	2.75	3.00	3.25	3.50	4.00	4.50	5.00		
3	1.50	1.75	2.00	2.25	2.25	2.50	2.50	2.75	3.00	3.25	3.50	3.75	4.00
4	2.25	2.75	3.25	3.50	4.00	4.50	4.75	5.00					
	1.75	2.00	2.00	2.00	2.25	2.25	2.50	2.50					
5	2.50	3.25	3.75	4.25	4.75	5.00							
	2.00	2.00	2.25	2.25	2.50	2.50							
6	3.25	4.25	5.00										
	2.25	2.50	2.50										
7	2.75	3.50	4.00	4.50	5.00								
	2.50	3.25	3.50	3.75	4.25								
8	2.00	2.50	3.00	3.25	3.50	4.00	4.25	4.50	5.00				
	2.00	2.50	2.75	3.00	3.00	3.25	3.25	3.25	3.25				
9	1.50	2.00	2.50	3.00	3.25	3.75	4.00	4.25	5.00				
10	1.25	1.50	1.75	2.00	2.25	2.50	2.50	2.75	3.00	3.25	3.75	4.25	4.50
11	1.00	1.25	1.50	1.75	2.00	2.25	2.50	2.50	3.00	3.25	3.75	4.50	5.00
12	2.50	3.00	3.25	3.75	4.00	4.25	4.50	5.00					
	2.25	2.50	2.50	2.75	2.75	2.75	2.75	2.75					
13	3.00	3.25	3.50	3.75	4.00	4.25	4.25	4.50	4.75	5.00			
	2.25	2.25	2.50	2.50	2.75	2.75	2.75	2.75	2.75	2.75			
14	1.50	2.00	2.25	2.50	2.75	2.75	3.00	3.25	3.50	3.75	4.25	4.50	5.00
	1.25	1.25	1.25	1.25	1.50	1.50	1.50	1.50	1.50	1.50	1.50	1.50	1.50
15	2.50	3.50	4.25	5.00									
	1.75	2.25	2.50	2.75									
16	2.25	2.75	3.25	3.75	4.00	4.50	4.75						
	2.00	2.25	2.75	2.75	2.75	3.00	3.25						
17	2.50	3.25	4.00	4.50	5.00								
	2.00	2.25	2.50	2.50	2.50								

Fragility Class G-6 (100g-124g) (Continued)

Material No.	Packaging Code												
	L1	L2	L3	L4	L5	L6	L7	L8	L9	L10	L11	L12	L13
	Weight per Unit Area of Article to be Packaged												
	Pounds per square inch												
	0.05 thru 0.09	0.10 thru 0.14	0.15 thru 0.19	0.20 thru 0.24	0.25 thru 0.29	0.30 thru 0.34	0.35 thru 0.39	0.40 thru 0.44	0.45 thru 0.54	0.55 thru 0.64	0.65 thru 0.84	0.85 thru 1.04	1.05 thru 1.25
	Inches												
18	3.50 2.00	4.50 2.00											
19	2.25 2.00	3.00 2.25	3.50 2.50	3.75 2.50	4.25 2.75	4.50 2.75	5.00 2.75						
20	3.00 2.00	4.00 2.25	5.00 2.50										
21	1.25	1.75	2.25	2.50	3.00	3.25	3.50	4.00	4.50	5.00			
22	1.25	1.75	2.00	2.25	2.75	3.00	3.25	3.50	4.00	4.50	5.00		
23	1.25	1.50	1.75	2.00	2.25	2.50	2.75	3.00	3.50	4.00	4.75		
24	4.00 3.25	4.50 3.25	4.75 3.25	5.00 3.25									
25	3.25 2.75	4.50 3.25											
26	3.00 2.75	3.75 3.25	4.50 3.50	5.00 3.25									
27	1.75 1.75	2.50 2.25	2.75 2.50	3.25 2.75	3.75 3.00	4.25 3.25	4.50 3.25	5.00 3.25					
28	3.00 2.75	3.50 3.00	3.50 3.00	3.75 3.25	3.75 3.25	4.00 3.25	4.00 3.25	4.25 3.50	4.25 3.50	4.50 3.50	4.75 3.50	5.00 3.75	5.00 3.75
29	3.25 3.00	3.50 3.25	3.75 3.25	3.75 3.25	4.00 3.50	4.00 3.50	4.25 3.50	4.25 3.50	4.50 3.50	4.50 3.50	4.75 3.75		
30	2.50 2.00	3.00 2.25	3.50 2.50	4.00 2.50	4.50 2.50	4.75 2.50	5.00 2.50						
32	3.25 2.75	4.00 3.00	4.75 3.25										
34	3.50 2.75	4.50 3.25											
35	2.75 2.00	3.50 2.25	4.00 2.25	4.50 2.25	4.75 2.50	5.00 2.50							

Material No.	Packaging Code												
	L1	L2	L3	L4	L5	L6	L7	L8	L9	L10	L11	L12	L13
	Weight per Unit Area of Article to be Packaged												
	Pounds per square inch												
	0.05 thru 0.09	0.10 thru 0.14	0.15 thru 0.19	0.20 thru 0.24	0.25 thru 0.29	0.30 thru 0.34	0.35 thru 0.39	0.40 thru 0.44	0.45 thru 0.54	0.55 thru 0.64	0.65 thru 0.84	0.85 thru 1.04	1.05 thru 1.25
	Inches												
1	1.50	2.00	2.50	3.00	3.50	4.00	4.25	4.75					
2	1.00	1.50	1.75	2.00	2.25	2.50	2.75	3.00	3.25	3.75	4.25	5.00	
3	1.25	1.50	1.75	1.75	2.00	2.25	2.25	2.25	2.50	2.75	3.00	3.25	3.50
4	2.00	2.25	2.75	3.00	3.50	3.75	4.00	4.25	4.75	5.00			
	1.50	1.50	1.75	1.75	2.00	2.00	2.00	2.00	2.00	2.00			
5	2.25	2.75	3.00	3.50	3.75	4.00	4.25	4.75	5.00				
	1.75	1.75	1.75	2.00	2.00	2.00	2.00	2.00	2.00				
6	2.75	3.50	4.25	4.75									
	2.00	2.00	2.25	2.25									
7	2.50	3.00	3.50	4.00	4.25	4.75							
	2.50	2.75	3.00	3.50	3.50	4.00							
8	1.75	2.00	2.50	2.75	3.00	3.25	3.50	3.75	4.25	4.75			
	1.75	2.00	2.25	2.50	2.75	2.75	2.75	2.75	2.75	2.75			
9	1.25	1.75	2.25	2.50	2.75	3.00	3.25	3.50	4.00	4.50	5.00		
10	1.25	1.50	1.75	1.75	2.00	2.00	2.25	2.25	2.50	2.75	3.25	3.50	3.75
11	.75	1.00	1.25	1.50	1.75	1.75	2.00	2.25	2.50	2.75	3.25	3.75	4.00
12	2.00	2.50	2.75	3.00	3.25	3.50	3.75	4.00	4.25	4.50	5.00		
	1.75	2.00	2.25	2.25	2.25	2.25	2.25	2.25	2.25	2.25	2.25		
13	2.25	2.75	3.00	3.00	3.25	3.50	3.50	3.75	3.75	4.00	4.25	4.50	4.75
	1.75	2.00	2.00	2.00	2.25	2.25	2.25	2.25	2.25	2.25	2.50	2.50	2.50
14	1.50	1.75	1.75	2.00	2.25	2.50	2.50	2.75	3.00	3.25	3.50	3.75	4.25
	1.25	1.25	1.25	1.25	1.25	1.25	1.25	1.25	1.25	1.25	1.25	1.25	1.25
15	2.25	2.75	3.50	4.00	4.50	5.00							
	1.75	1.75	2.00	2.25	2.25	2.50							
16	1.75	2.25	2.75	3.00	3.25	3.50	4.00	4.00	4.50	5.00			
	1.50	2.00	2.25	2.25	2.25	2.25	2.50	2.50	2.50	2.50			
17	2.25	2.75	3.25	3.75	4.25	4.50	4.75						
	1.75	2.00	2.00	2.00	2.00	2.00	2.00						

Fragility Class G-7 (125g-149g) (Continued)

Material No.	Packaging Code												
	L1	L2	L3	L4	L5	L6	L7	L8	L9	L10	L11	L12	L13
	Weight per Unit Area of Article to be Packaged												
	Pounds per square inch												
	0.05 thru 0.09	0.10 thru 0.14	0.15 thru 0.19	0.20 thru 0.24	0.25 thru 0.29	0.30 thru 0.34	0.35 thru 0.39	0.40 thru 0.44	0.45 thru 0.54	0.55 thru 0.64	0.65 thru 0.84	0.85 thru 1.04	1.05 thru 1.25
	Inches												
18	3.00 1.75	3.75 1.75	4.50 2.00										
19	2.00 1.75	2.50 2.00	2.75 2.00	3.25 2.25	3.50 2.25	3.75 2.25	4.25 2.25	4.50 2.25	5.00 2.25				
20	2.50 1.75	3.50 2.00	4.25 2.00	5.00 2.25									
21	1.25	1.50	2.00	2.25	2.50	2.75	3.00	3.25	3.75	4.25	5.00		
22	1.00	1.50	1.75	2.00	2.25	2.50	2.75	3.00	3.25	3.75	4.50	5.00	
23	1.00	1.25	1.50	1.75	2.00	2.00	2.50	2.50	3.00	3.25	4.00	4.75	5.00
24	3.50 2.75	3.75 2.75	4.00 2.75	4.25 2.75	4.50 2.50	4.50 2.50	4.50 2.50	4.75 2.50	5.00 2.50				
25	3.00 2.50	4.00 3.00	5.00 3.50										
26	2.75 2.50	3.25 2.75	4.00 3.00	4.50 3.00	5.00 2.75								
27	1.50 1.50	2.00 2.00	2.50 2.25	3.00 2.50	3.25 2.75	3.75 2.75	4.00 3.00	4.50 3.00	5.00 3.00				
28	2.50 2.50	2.75 2.50	3.00 2.50	3.00 2.50	3.00 2.50	3.25 2.75	3.25 2.75	3.50 2.75	3.50 2.75	3.50 2.75	3.75 3.00	4.00 3.00	4.00 3.00
29	2.50 2.50	2.75 2.50	2.75 2.50	3.00 2.75	3.00 2.75	3.25 2.75	3.25 2.75	3.25 2.75	3.50 2.75	3.50 2.75	3.50 2.75	3.75 3.00	4.00 3.00
30	2.00 1.75	2.50 2.00	3.00 2.00	3.25 2.00	3.75 2.25	4.00 2.25	4.50 2.25	5.00 2.25					
32	2.75 2.25	3.25 2.25	3.75 2.75	4.25 2.75	4.50 2.75	5.00 2.75							
34	3.00 2.50	4.00 2.75	4.75 2.75										
35	2.25 1.75	2.75 1.75	3.25 1.75	3.50 1.75	4.00 2.00	4.25 2.00	4.50 2.00	4.75 2.00					

Material No.	Packaging Code												
	L1	L2	L3	L4	L5	L6	L7	L8	L9	L10	L11	L12	L13
	Weight per Unit Area of Article to be Packaged												
	Pounds per square inch												
	0.05 thru 0.09	0.10 thru 0.14	0.15 thru 0.19	0.20 thru 0.24	0.25 thru 0.29	0.30 thru 0.34	0.35 thru 0.39	0.40 thru 0.44	0.45 thru 0.54	0.55 thru 0.64	0.65 thru 0.84	0.85 thru 1.04	1.05 thru 1.25
	Inches												
1	1.25	1.75	2.00	2.50	3.00	3.25	3.75	4.00	4.75				
2	1.00	1.25	1.50	1.75	2.00	2.00	2.25	2.50	2.75	3.00	3.75	4.25	4.75
3	1.00	1.25	1.50	1.75	1.75	2.00	2.00	2.00	2.25	2.50	2.75	3.00	3.25
4	1.75	2.00	2.50	2.75	3.00	3.25	3.50	3.75	4.00	4.50	5.00		
	1.50	1.50	1.50	1.50	1.75	1.75	1.75	1.75	1.75	2.00	2.00		
5	2.00	2.00	2.75	3.00	3.25	3.50	3.75	4.00	4.50	5.00			
	1.50	1.50	1.75	1.75	1.75	1.75	1.75	1.75	2.00	2.00			
6	2.50	3.00	3.75	4.25	4.75	5.00							
	1.75	1.75	2.00	2.00	2.00	1.75							
7	2.25	2.75	3.25	3.50	4.00	4.25	4.50	4.75					
	2.25	2.50	3.00	3.00	3.50	3.50	3.50	3.75					
8	1.50	1.75	2.25	2.50	2.75	3.00	3.00	3.25	3.75	4.00	4.75		
	1.50	1.75	2.00	2.25	2.50	2.50	2.50	2.25	2.50	2.25	2.50		
9	1.25	1.50	1.75	2.25	2.50	2.75	3.00	3.00	3.50	4.00	4.75	5.00	
10	1.00	1.25	1.50	1.50	1.75	1.75	2.00	2.00	2.25	2.50	2.75	3.00	3.50
11	.75	1.00	1.25	1.25	1.50	1.50	1.75	2.00	2.25	2.50	2.75	3.25	3.50
12	1.75	2.00	2.25	2.50	2.75	3.00	3.25	3.25	3.50	3.75	4.25	4.50	5.00
	1.50	1.75	1.75	1.75	1.75	1.75	1.75	1.75	2.00	2.00	2.00	2.00	2.00
13	2.00	2.25	2.50	2.50	2.75	3.00	3.00	3.00	3.25	3.50	3.75	4.00	4.00
	1.50	1.75	1.75	1.75	1.75	1.75	1.75	1.75	2.00	2.00	2.00	2.25	2.25
14	1.25	1.50	1.75	1.75	2.00	2.25	2.25	2.50	2.75	2.75	3.00	3.50	3.50
	1.00	1.00	1.00	1.00	1.00	1.25	1.25	1.25	1.50	1.00	1.00	1.00	1.00
15	2.00	2.50	3.00	3.50	3.75	4.25	4.50	5.00					
	1.50	1.75	1.75	1.75	1.75	2.00	2.00	2.00					
16	1.50	2.00	2.25	2.50	2.75	3.00	3.25	3.50	4.00	4.25	5.00		
	1.25	1.75	1.75	1.75	1.75	1.75	2.00	2.00	2.00	2.00	2.00		
17	2.00	2.25	2.75	3.25	3.50	4.00	4.25	4.50	5.00				
	1.50	1.50	1.50	1.75	1.75	1.75	1.75	1.75	1.75				

Fragility Class G-8 (150g-199g) (Continued)

Material No.	Packaging Code												
	L1	L2	L3	L4	L5	L6	L7	L8	L9	L10	L11	L12	L13
	Weight per Unit Area of Article to be Packaged												
	Pounds per square inch												
	0.05 thru 0.09	0.10 thru 0.14	0.15 thru 0.19	0.20 thru 0.24	0.25 thru 0.29	0.30 thru 0.34	0.35 thru 0.39	0.40 thru 0.44	0.45 thru 0.54	0.55 thru 0.64	0.65 thru 0.84	0.85 thru 1.04	1.05 thru 1.25
	Inches												
18	2.50 1.25	3.25 1.50	4.00 1.75	4.75 1.75									
19	1.75 1.50	2.25 1.75	2.50 1.75	2.75 2.00	3.00 2.00	3.50 2.00	3.75 2.00	3.75 2.00	4.25 2.00	4.50 2.00	5.00 2.00		
20	2.25 1.50	3.00 1.75	3.75 1.75	4.50 2.00	5.00 2.00								
21	1.00	1.25	1.75	2.00	2.25	2.50	2.75	3.00	3.25	3.75	4.50	5.00	
22	1.00	1.25	1.50	1.75	2.00	2.25	2.50	2.50	3.00	3.25	4.00	4.50	5.00
23	0.75	1.00	1.25	1.50	1.75	2.00	2.00	2.25	2.50	3.00	3.50	4.25	4.75
24	3.00 2.25	3.25 2.25	3.50 2.25	3.75 2.25	3.75 2.25	4.00 2.25	4.00 2.25	4.00 2.25	4.25 2.25	4.50 2.25	4.75 2.25	5.00 2.75	5.00 2.75
25	3.00 2.50	3.75 2.75	4.50 3.00										
26	2.50 2.50	3.00 2.50	3.50 2.75	4.00 2.50	4.50 2.50	4.75 2.50	5.00 2.25						
27	1.50 1.50	2.00 2.00	2.25 2.00	2.75 2.25	3.00 2.50	3.25 2.50	3.75 2.50	4.00 2.50	4.50 2.50	5.00 2.50			
28	2.25 2.00	2.25 2.00	2.50 2.25	2.50 2.25	2.50 2.25	2.75 2.25	2.75 2.25	2.75 2.25	3.00 2.50	3.00 2.50	3.25 2.50	3.25 2.50	3.50 2.50
29	2.00 2.00	2.25 2.00	2.25 2.00	2.25 2.00	2.50 2.25	2.50 2.25	2.50 2.25	2.50 2.25	2.75 2.25	2.75 2.25	2.75 2.25	3.00 2.50	3.00 2.50
30	1.75 1.50	2.00 1.50	2.50 1.75	2.75 1.75	3.00 1.75	3.25 1.75	3.75 2.00	4.00 2.00	4.25 2.00	4.75 2.00			
32	2.25 1.75	2.75 2.00	3.25 2.25	3.50 2.25	3.75 2.25	4.25 2.25	4.50 2.25	4.75 2.25					
34	2.50 2.00	3.50 2.50	4.25 2.50	5.00 2.75									
35	2.00 1.50	2.25 1.50	2.75 1.50	3.00 1.50	3.50 1.75	3.75 1.75	4.00 2.00	4.25 2.00	4.50 2.00	5.00 2.00			

Material No.	Packaging Code												
	L1	L2	L3	L4	L5	L6	L7	L8	L9	L10	L11	L12	L13
	Weight per Unit Area of Article to be Packaged												
	Pounds per square inch												
	0.05 thru 0.09	0.10 thru 0.14	0.15 thru 0.19	0.20 thru 0.24	0.25 thru 0.29	0.30 thru 0.34	0.35 thru 0.39	0.40 thru 0.44	0.45 thru 0.54	0.55 thru 0.64	0.65 thru 0.84	0.85 thru 1.04	1.05 thru 1.25
	Inches												
1	1.00	1.25	1.75	2.00	2.25	2.50	2.75	3.25	3.75	4.25	5.00		
2	.75	1.00	1.25	1.50	1.50	1.75	1.75	2.00	2.25	2.50	3.00	3.50	3.75
3	1.00	1.25	1.25	1.50	1.50	1.50	1.75	1.75	2.00	2.00	2.25	2.50	2.75
4	1.25	1.75	2.00	2.00	2.25	2.50	2.75	3.00	3.25	3.50	4.00	4.25	5.00
	1.00	1.25	1.25	1.25	1.25	1.50	1.50	1.50	1.50	1.50	1.50	1.50	1.75
5	1.50	1.75	2.25	2.50	2.75	3.00	3.00	3.25	3.50	3.75	4.50	5.00	
	1.25	1.25	1.50	1.50	1.50	1.50	1.50	1.50	1.50	1.50	1.75	1.75	
6	2.00	2.50	3.00	3.50	3.75	4.00	4.50	4.75	5.00				
	1.25	1.50	1.50	1.50	1.50	1.50	1.50	1.50	1.50				
7	1.75	2.25	2.75	3.00	3.25	3.50	3.75	4.00	4.50	5.00			
	1.75	2.00	2.50	2.50	2.50	2.50	2.50	2.50	2.50	2.50			
8	1.25	1.50	1.75	2.00	2.25	2.25	2.50	2.75	3.00	3.25	3.75	4.25	4.75
	1.25	1.50	1.50	1.75	2.00	2.00	2.00	2.00	2.00	2.00	2.00	2.00	2.00
9	1.00	1.25	1.50	1.75	2.00	2.25	2.50	2.50	3.00	3.25	3.75	4.25	5.00
10	.75	1.00	1.25	1.25	1.50	1.50	1.75	1.75	2.00	2.00	2.25	2.50	2.75
11	.75	.75	1.00	1.00	1.25	1.25	1.50	1.50	1.75	2.00	2.25	2.50	2.75
12	1.50	1.50	1.75	2.00	2.25	2.25	2.50	2.50	2.75	3.00	3.25	3.50	3.75
	1.25	1.25	1.25	1.25	1.50	1.50	1.50	1.50	1.50	1.50	1.50	1.50	1.50
13	1.50	1.75	2.00	2.00	2.00	2.25	2.25	2.50	2.50	2.75	2.75	3.00	3.00
	1.25	1.25	1.25	1.25	1.25	1.50	1.50	1.50	1.50	1.50	1.50	1.50	1.50
14	1.00	1.25	1.25	1.50	1.75	1.75	2.00	2.00	2.00	2.25	2.50	2.75	3.00
	.75	1.00	1.00	1.00	1.00	1.00	1.00	1.00	1.00	1.00	1.00	1.00	1.00
15	1.50	2.00	2.25	2.50	3.00	3.25	3.50	3.75	4.25	4.75			
	1.25	1.25	1.25	1.25	1.25	1.50	1.50	1.50	1.50	1.50			
16	1.25	1.50	1.50	2.00	2.25	2.50	2.50	2.75	3.00	3.25	3.75	4.25	4.75
	1.00	1.25	1.25	1.50	1.50	1.50	1.50	1.50	1.50	1.50	1.50	1.50	1.75
17	1.50	2.00	2.25	2.50	3.00	3.25	3.50	3.75	4.00	4.50	5.00		
	1.25	1.25	1.25	1.25	1.25	1.25	1.50	1.50	1.50	1.50	1.50		

Fragility Class G-9 (200g-249g) (Continued)

Material No.	Packaging Code												
	L1	L2	L3	L4	L5	L6	L7	L8	L9	L10	L11	L12	L13
	Weight per Unit Area of Article to be Packaged												
	Pounds per square inch												
	0.05 thru 0.09	0.10 thru 0.14	0.15 thru 0.19	0.20 thru 0.24	0.25 thru 0.29	0.30 thru 0.34	0.35 thru 0.39	0.40 thru 0.44	0.45 thru 0.54	0.55 thru 0.64	0.65 thru 0.84	0.85 thru 1.04	1.05 thru 1.25
	Inches												
18	2.00 1.25	2.75 1.25	3.25 1.50	3.75 1.50	4.25 1.50	4.50 1.50	5.00 1.50						
19	1.50 1.25	1.75 1.50	2.00 1.50	2.25 1.50	2.50 1.50	2.75 1.50	2.75 1.50	3.00 1.50	3.50 1.50	3.75 1.50	4.25 1.50	4.75 1.50	
20	1.75 1.25	2.50 1.25	3.00 1.50	3.50 1.50	4.00 1.50	5.00 1.50	5.00 1.50						
21	.75	1.00	1.25	1.50	1.75	2.00	2.25	2.25	2.75	3.00	3.75	4.25	4.75
22	.75	1.00	1.25	1.50	1.50	1.75	2.00	2.00	2.25	2.50	3.00	3.50	4.00
23	.75	.75	1.00	1.25	1.50	1.50	1.75	1.75	2.00	2.25	3.00	3.25	3.75
24	2.25 2.00	2.50 2.00	2.75 2.00	2.75 2.00	3.00 2.00	3.00 2.00	3.25 2.00	3.25 2.00	3.50 2.00	3.50 2.00	3.75 1.75	3.75 1.75	4.00 1.75
25	2.50 2.25	3.50 2.75	4.25 3.00	4.75 2.75									
26	2.00 2.00	2.75 2.50	3.00 2.50	3.50 2.25	3.75 2.25	4.00 2.25	4.50 2.00	4.75 2.00					
27	1.25 1.25	1.50 1.50	2.00 1.75	2.25 2.00	2.50 2.00	2.75 2.00	3.25 2.00	3.50 2.25	3.75 2.25	4.25 2.25	5.00 2.25		
28	1.75 1.50	1.75 1.50	1.75 1.50	2.00 1.75	2.00 1.75	2.00 1.75	2.00 1.75	2.25 1.75	2.25 1.75	2.25 1.75	2.50 2.00	2.50 2.00	2.50 2.00
29	1.50 1.50	1.50 1.50	1.50 1.50	1.75 1.50	1.75 1.50	1.75 1.50	1.75 1.50	1.75 1.50	2.00 1.75	2.00 1.75	2.00 1.75	2.00 1.75	2.25 1.75
30	1.25 1.00	1.75 1.25	2.00 1.50	2.25 1.50	2.50 1.50	2.75 1.50	2.75 1.50	3.00 1.50	3.25 1.50	3.50 1.50	4.00 1.50	4.75 1.50	5.00 1.50
32	1.75 1.50	2.25 1.75	2.50 1.75	2.75 1.75	3.00 1.75	3.25 1.75	3.50 1.75	3.75 1.75	4.00 1.75	4.50 1.75	5.00 1.50		
34	2.25 1.75	3.00 2.25	3.50 2.25	4.00 2.25	4.75 2.25								
35	1.50 1.25	2.00 1.25	2.25 1.25	2.50 1.25	2.75 1.25	2.75 1.25	3.00 1.25	3.25 1.50	3.50 1.50	4.00 1.50	4.25 1.50	4.75 1.50	5.00 1.75

Material No.	Packaging Code												
	L1	L2	L3	L4	L5	L6	L7	L8	L9	L10	L11	L12	L13
	Weight per Unit Area of Article to be Packaged												
	Pounds per square inch												
	0.05 thru 0.09	0.10 thru 0.14	0.15 thru 0.19	0.20 thru 0.24	0.25 thru 0.29	0.30 thru 0.34	0.35 thru 0.39	0.40 thru 0.44	0.45 thru 0.54	0.55 thru 0.64	0.65 thru 0.84	0.85 thru 1.04	1.05 thru 1.25
	Inches												
1	.75	1.25	1.50	1.75	2.00	2.25	2.50	2.50	3.00	3.50	4.25	5.00	
2	.75	.75	1.00	1.5	1.5	1.5	1.5	1.75	2.00	2.5	2.5	2.75	3.00
3	.75	1.00	1.0	1.5	1.5	1.5	1.5	1.5	1.75	1.75	2.00	2.0	2.25
4	1.00	1.50	1.50	1.75	2.00	2.25	2.50	2.50	2.75	3.00	3.25	3.75	4.00
	1.00	1.00	1.00	1.00	1.00	1.25	1.5	1.5	1.5	1.5	1.5	1.5	1.25
5	1.25	1.50	1.75	2.00	2.25	2.50	2.5	2.75	3.00	3.5	3.75	4.00	4.50
	1.00	1.00	1.00	1.00	1.5	1.5	1.5	1.5	1.5	1.5	1.5	1.50	1.50
6	1.75	2.25	2.50	2.75	3.25	3.50	3.75	4.00	4.50	5.00			
	1.00	1.25	1.25	1.25	1.25	1.25	1.25	1.25	1.25	1.25			
7	1.50	2.00	2.5	2.75	3.00	3.25	3.50	3.75	4.00	4.50	5.00		
	1.50	2.00	2.00	2.5	2.50	2.25	2.25	2.25	2.25	2.5	2.00		
8	1.00	1.25	1.50	1.75	1.75	2.00	2.25	2.25	2.50	2.75	3.25	3.50	4.00
	1.00	1.25	1.50	1.50	1.5	1.75	1.5	1.5	1.75	1.75	1.75	1.75	1.75
9	.75	1.00	1.25	1.50	1.75	1.75	2.00	2.25	2.50	2.75	3.5	3.50	4.00
10	.75	1.00	1.0	1.25	1.00	1.5	1.50	1.50	1.75	1.75	2.00	2.25	2.25
11	.50	.75	.75	1.00	1.00	1.25	1.25	1.25	1.50	1.50	2.00	2.25	2.50
12	1.5	1.25	1.50	1.75	1.75	2.00	2.00	2.25	2.25	2.5	2.75	3.00	3.25
	1.00	1.00	1.00	1.25	1.25	1.25	1.25	1.25	1.25	1.5	1.25	1.5	1.5
13	1.25	1.50	1.50	1.75	1.75	1.75	2.00	2.00	2.00	2.25	2.25	2.5	2.50
	1.00	1.00	1.00	1.25	1.25	1.25	1.25	1.25	1.25	1.5	1.25	1.5	1.50
14	1.20	1.00	1.5	1.25	1.50	1.5	1.5	1.75	1.75	2.0	2.25	2.25	2.50
	.75	.75	.75	.75	.75	.75	.75	.75	.75	.75	.75	.75	.75
15	1.25	1.50	2.00	2.5	2.5	2.75	3.00	3.00	3.5	3.75	4.5	5.00	
	1.00	1.00	1.00	1.25	1.25	1.25	1.25	1.25	1.25	1.25	1.25	1.25	
16	1.00	1.25	1.50	1.75	2.00	2.00	2.25	2.50	2.5	2.75	3.25	3.5	4.00
	1.00	1.00	1.00	1.25	1.25	1.25	1.25	1.25	1.25	1.25	1.25	1.25	1.25
17	1.25	1.75	2.00	2.25	2.50	2.75	3.00	3.00	3.50	3.75	4.50	5.00	
	1.00	1.00	1.00	1.00	1.00	1.00	1.00	1.00	1.00	1.00	1.00	1.25	

Fragility Class G-10 (250g-299g) (Continued)

Material No.	Packaging Code												
	L1	L2	L3	L4	L5	L6	L7	L8	L9	L10	L11	L12	L13
	Weight per Unit Area of Article to be Packaged												
	Pounds per square inch												
	0.05 thru 0.09	0.10 thru 0.14	0.15 thru 0.19	0.20 thru 0.24	0.25 thru 0.29	0.30 thru 0.34	0.35 thru 0.39	0.40 thru 0.44	0.45 thru 0.54	0.55 thru 0.64	0.65 thru 0.84	0.85 thru 1.04	1.05 thru 1.25
	Inches												
18	1.75 1.00	2.25 1.00	2.75 1.00	3.00 1.00	3.50 1.00	3.75 1.00	4.50 1.00	5.00 1.25					
19	1.25 1.00	1.50 1.25	1.75 1.25	2.00 1.25	2.25 1.25	2.25 1.25	2.50 1.25	2.50 1.25	3.00 1.25	3.25 1.25	3.75 1.25	4.00 1.25	4.50 1.25
20	1.50 1.00	2.00 1.00	2.50 1.25	3.00 1.25	3.50 1.25	3.75 1.50	4.00 1.50	4.50 1.50					
21	.75	1.00	1.25	1.25	1.50	1.75	2.00	2.00	2.25	2.50	3.00	3.50	4.00
22	.75	.75	1.00	1.25	1.25	1.50	1.75	1.75	2.00	2.25	2.50	3.00	3.50
23	.50	.75	1.00	1.00	1.25	1.25	1.50	1.50	1.75	2.00	2.50	3.00	3.25
24	2.00 1.50	2.25 1.50	2.25 1.50	2.50 1.50	2.50 1.50	2.50 1.50	2.75 1.50	2.75 1.50	2.75 1.50	3.00 1.50	3.00 1.50	3.25 1.50	3.25 1.50
25	2.50 2.25	3.25 2.50	3.75 2.50	4.50 2.50									
26	1.75 1.75	2.25 2.00	2.75 2.25	3.00 2.00	3.50 2.00	3.75 2.00	4.00 2.00	4.25 2.00	4.75 1.75	5.00 1.75			
27	1.25 1.25	1.50 1.50	1.75 1.50	2.00 1.75	2.25 2.00	2.50 2.00	2.75 2.00	3.00 2.00	3.50 2.00	3.75 2.00	4.50 2.00	5.00 2.00	
28	1.25 1.25	1.50 1.25	1.50 1.25	1.50 1.25	1.75 1.50	1.75 1.50	1.75 1.50	1.75 1.50	1.75 1.50	1.75 1.50	2.00 1.50	2.00 1.50	2.00 1.50
29	1.00 1.00	1.25 1.25	1.25 1.25	1.25 1.25	1.25 1.25	1.25 1.25	1.50 1.25	1.50 1.25	1.50 1.25	1.50 1.25	1.50 1.25	1.50 1.25	1.75 1.50
30	1.00 1.00	1.50 1.00	1.50 1.00	1.75 1.00	2.00 1.00	2.25 1.25	2.25 1.25	2.50 1.25	2.75 1.25	3.00 1.25	3.50 1.25	3.75 1.25	4.25 1.25
32	1.50 1.25	1.75 1.25	2.00 1.50	2.25 1.50	2.50 1.50	2.75 1.50	2.75 1.50	3.00 1.50	3.25 1.25	3.50 1.25	4.00 1.25	4.50 1.25	4.75 1.25
34	2.00 1.75	2.50 1.75	3.00 2.00	3.50 2.00	4.00 2.00	4.50 2.00	5.00 2.00						
35	1.25 1.00	1.50 1.00	1.75 1.00	2.00 1.00	2.25 1.25	2.25 1.25	2.50 1.25	2.75 1.25	3.00 1.25	3.25 1.25	3.50 1.25	4.00 1.25	4.50 1.50

Material No.	Packaging Code												
	L1	L2	L3	L4	L5	L6	L7	L8	L9	L10	L11	L12	L13
	Weight per Unit Area of Article to be Packaged												
	Pounds per square inch												
	0.05 thru 0.09	0.10 thru 0.14	0.15 thru 0.19	0.20 thru 0.24	0.25 thru 0.29	0.30 thru 0.34	0.35 thru 0.39	0.40 thru 0.44	0.45 thru 0.54	0.55 thru 0.64	0.65 thru 0.84	0.85 thru 1.04	1.05 thru 1.25
	Inches												
1	.75	1.00	1.25	1.50	1.75	2.00	2.00	2.25	2.50	3.00	3.50	4.00	5.00
2	.50	.75	.75	1.00	1.25	1.25	1.25	1.50	1.50	1.75	2.00	2.50	2.75
3	.75	1.00	1.00	1.00	1.25	1.25	1.25	1.50	1.50	1.50	1.75	2.00	2.00
4	1.00	1.25	1.50	1.50	1.75	1.75	2.00	2.00	2.25	2.50	2.75	3.25	3.50
	1.00	1.00	1.00	1.00	1.00	1.00	1.00	1.00	1.00	1.00	1.00	1.25	1.25
5	1.25	1.50	1.50	1.75	2.00	2.00	2.25	2.25	2.50	2.75	3.25	3.50	4.00
	1.00	1.00	1.00	1.00	1.00	1.00	1.00	1.00	1.00	1.00	1.25	1.25	1.25
6	1.50	1.75	2.25	2.50	2.75	3.00	3.25	3.50	4.00	4.25	5.00		
	1.00	1.00	1.00	1.00	1.00	1.00	1.00	1.00	1.00	1.00	1.00		
7	1.50	1.75	2.00	2.50	2.50	2.75	3.00	3.25	3.50	4.00	4.50	5.00	
	1.50	1.50	1.75	2.00	2.00	2.00	2.00	2.00	2.00	2.00	2.00	1.75	
8	1.00	1.25	1.25	1.50	1.75	1.75	2.00	2.00	2.25	2.50	2.75	3.00	3.50
	1.00	1.25	1.25	1.25	1.50	1.50	1.50	1.50	1.50	1.50	1.50	1.50	1.50
9	.75	1.00	1.25	1.25	1.50	1.75	1.75	2.00	2.00	2.00	2.75	3.25	3.50
10	.75	.75	1.00	1.00	1.25	1.25	1.25	1.25	1.50	1.50	1.75	2.00	2.25
11	.50	.50	.75	.75	1.00	1.00	1.00	1.25	1.25	1.50	1.75	2.00	2.00
12	1.00	1.25	1.25	1.50	1.75	1.75	1.75	1.75	2.00	2.00	2.25	2.50	2.75
	1.00	1.00	1.00	1.00	1.00	1.00	1.00	1.00	1.00	1.00	1.00	1.00	1.00
13	1.00	1.25	1.25	1.50	1.50	1.50	1.75	1.75	1.75	1.75	2.00	2.00	2.25
	1.00	1.00	1.00	1.00	1.00	1.00	1.00	1.00	1.00	1.00	1.00	1.00	1.25
14	.75	1.00	1.00	1.25	1.25	1.25	1.50	1.50	1.75	1.75	2.00	2.00	2.25
	.75	.75	.75	.75	.75	.75	.75	.75	.75	.75	.75	.75	.75
15	1.00	1.25	1.50	1.75	2.00	2.25	2.50	2.75	3.00	3.25	3.75	4.25	5.00
	.75	.75	.75	1.00	1.00	1.00	1.00	1.00	1.00	1.00	1.00	1.00	1.00
16	1.00	1.25	1.50	1.50	1.75	1.75	2.00	2.00	2.25	2.50	2.75	3.00	3.50
	1.00	1.00	1.00	1.00	1.00	1.00	1.00	1.00	1.00	1.00	1.00	1.00	1.00
17	1.25	1.50	1.75	2.00	2.00	2.25	2.50	2.75	3.00	3.25	4.00	4.50	5.00
	1.00	1.00	1.00	1.00	1.00	1.00	1.00	1.00	1.00	1.00	1.00	1.00	1.00

Fragility Class G-11 (300g-350g) (Continued)

Material No.	Packaging Code												
	L1	L2	L3	L4	L5	L6	L7	L8	L9	L10	L11	L12	L13
	Weight per Unit Area of Article to be Packaged												
	Pounds per square inch												
	0.05 thru 0.09	0.10 thru 0.14	0.15 thru 0.19	0.20 thru 0.24	0.25 thru 0.29	0.30 thru 0.34	0.35 thru 0.39	0.40 thru 0.44	0.45 thru 0.54	0.55 thru 0.64	0.65 thru 0.84	0.85 thru 1.04	1.05 thru 1.25
	Inches												
18	1.50 1.00	2.00 1.00	2.50 1.00	2.75 1.00	3.00 1.00	3.25 1.00	3.75 1.00	4.00 1.00	4.50 1.00	4.75 1.00			
19	1.00 1.00	1.25 1.00	1.50 1.00	1.75 1.00	2.00 1.00	2.00 1.00	2.25 1.00	2.25 1.00	2.50 1.00	2.75 1.00	3.25 1.00	3.50 1.00	4.00 1.00
20	1.25 1.00	1.75 1.00	2.25 1.00	2.50 1.00	3.00 1.00	3.25 1.00	3.50 1.00	3.75 1.00	4.50 1.00	5.00 1.00			
21	.75	.75	1.00	1.25	1.25	1.50	1.75	1.75	2.00	2.25	2.75	3.25	3.50
22	.50	.75	1.00	1.00	1.25	1.25	1.50	1.50	1.75	2.00	2.25	2.50	3.00
23	.50	.75	.75	1.00	1.00	1.25	1.25	1.50	1.50	1.75	2.25	2.50	2.75
24	1.75 1.25	1.75 1.25	2.00 1.25	2.25 1.25	2.25 1.25	2.25 1.25	2.25 1.25	2.50 1.25	2.50 1.25	2.50 1.25	2.75 1.25	2.75 1.25	3.00 1.25
25	2.25 2.00	3.00 2.50	3.50 2.50	4.25 2.50	4.75 2.50								
26	1.75 1.75	2.25 2.00	2.50 2.00	2.75 2.00	3.25 2.00	3.50 2.00	3.75 1.75	4.00 1.75	4.25 1.50	4.75 1.50			
27	1.00 1.00	1.25 1.25	1.75 1.50	2.00 1.75	2.25 2.00	2.50 2.00	2.50 1.75	2.75 1.75	3.25 2.00	3.50 2.00	4.00 1.75	4.75 2.00	
28	1.00 1.00	1.25 1.25	1.25 1.25	1.25 1.25	1.25 1.25	1.50 1.25	1.50 1.25	1.50 1.25	1.50 1.25	1.50 1.25	1.75 1.25	1.75 1.25	1.75 1.25
29	1.00 1.00	1.00 1.00	1.00 1.00	1.00 1.00	1.00 1.00	1.00 1.00	1.25 1.00	1.25 1.00	1.25 1.00	1.25 1.00	1.25 1.00	1.25 1.00	1.50 1.25
30	1.00 1.00	1.25 1.00	1.50 1.00	1.50 1.00	1.75 1.00	2.00 1.00	2.00 1.00	2.25 1.00	2.25 1.00	2.50 1.00	3.00 1.00	3.25 1.00	3.50 1.00
32	1.25 1.00	1.50 1.25	1.75 1.25	2.00 1.25	2.00 1.25	2.25 1.25	2.50 1.25	2.50 1.25	2.75 1.00	3.00 1.00	3.50 1.00	3.75 1.00	4.25 1.00
34	1.75 1.50	2.25 1.50	2.75 1.75	3.25 1.75	3.50 1.75	4.00 1.75	4.25 1.75	4.75 2.00					
35	1.00 1.00	1.25 1.00	1.50 1.00	1.75 1.00	2.00 1.00	2.00 1.00	2.25 1.00	2.25 1.00	2.50 1.00	2.75 1.00	3.25 1.25	3.50 1.25	3.75 1.25

Figure 1.--Increase bearing surface by use of fiberboard.

(M 92784 F)

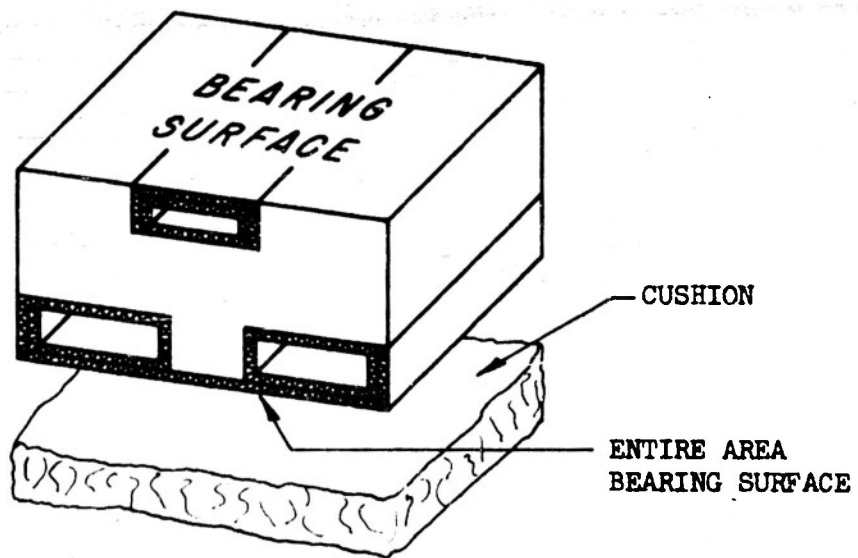
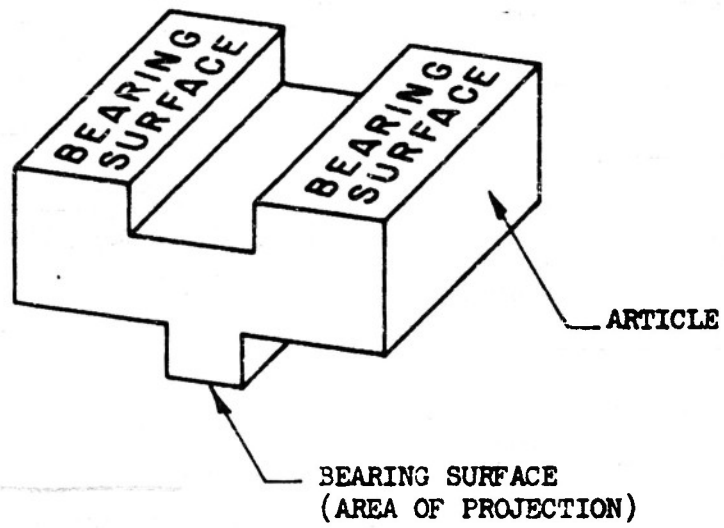
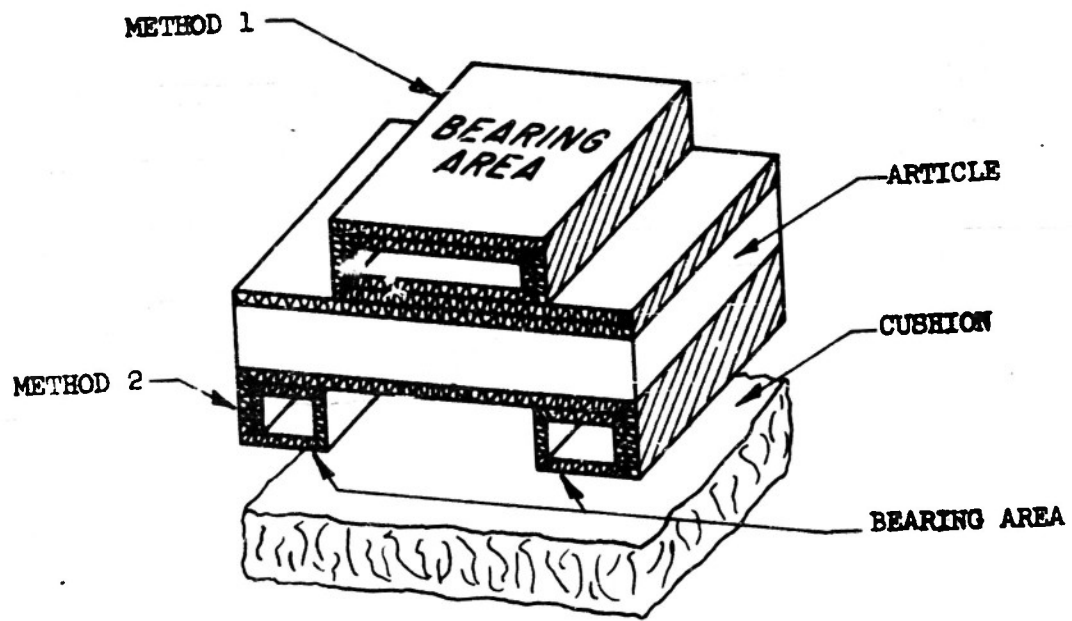
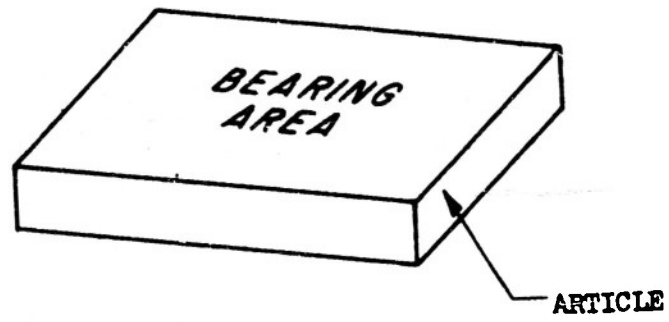

Figure 2.--Two methods of reducing bearing surface by  
use of fiberboard.

(M 92785 F)



A 92785 r

Figure 3.--Determination of weight per unit area for each  
face of article to be cushioned and  
illustration of cushion design.

(M 90991 F)

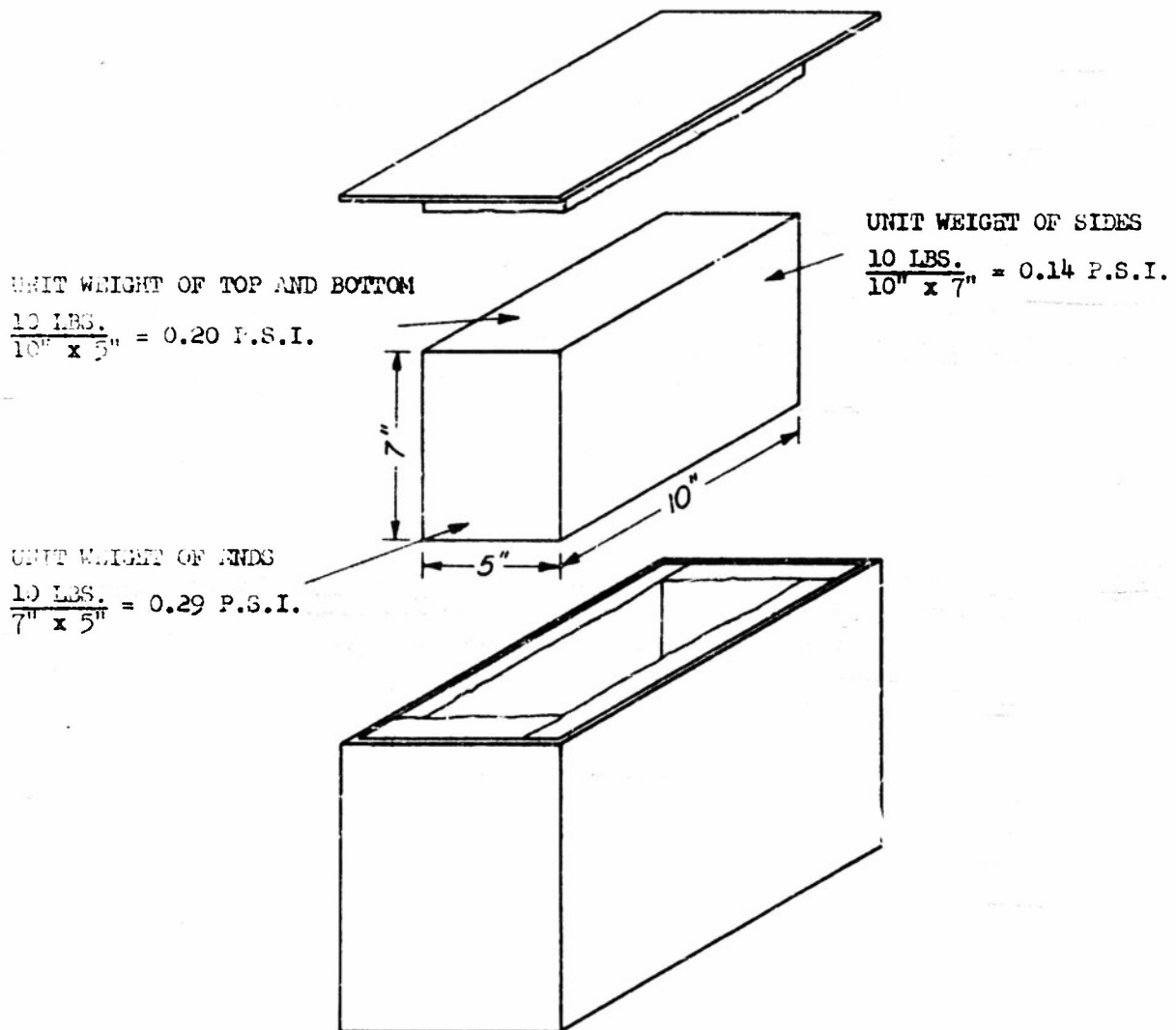

NOTE: DIMENSIONS OF OUTER CONTAINER DEPEND UPON SIZE  
 OF ARTICLE TO BE PACKED AND THICKNESS OF CUSHION  
 REQUIRED AS DETERMINED BY DESIGN METHOD A, B, OR C.

Figure 4.--Basic data for "Comparison of Cushion Designs,"  
page 17, illustrating the various amounts  
of cushioning necessary when using cushioning  
methods A, B or C.

(M 90992 F)

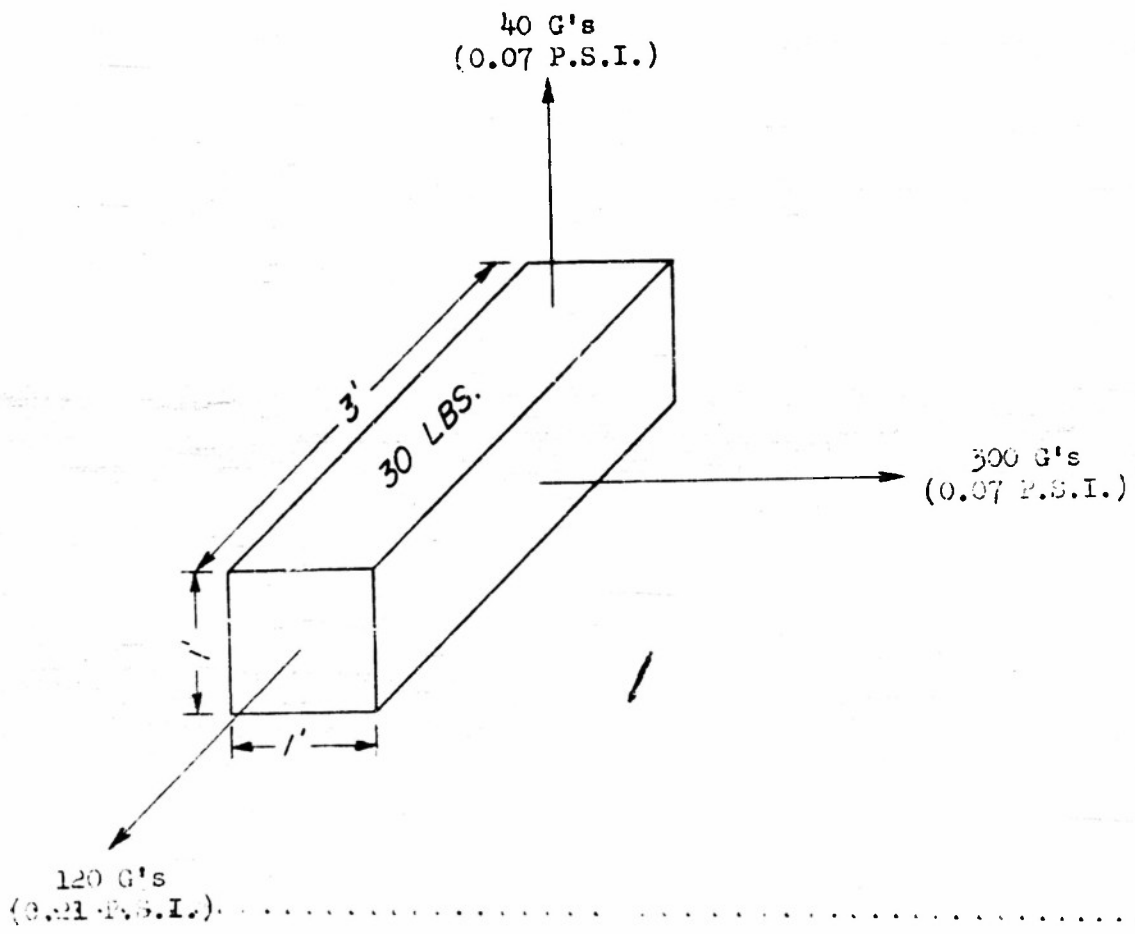

M 10000 P

Figure 5.--Cushioning of irregular shaped article, showing  
method of determining weight per unit area  
and illustrating two methods of holding  
cushioning material in place.

(M 90990 F)

CUSHIONING OF IRREGULAR SHAPED ARTICLE

PACKAGING CONDITIONS: WT. OF ARTICLE--10 LBS.; FRAGILITY--80G (05);  
DROP HEIGHT--30"

$\frac{10 \text{ LBS.}}{3.14" \times 2^2"} = 0.80 \text{ P.S.I.}$   
(PACKAGING CODE L11)

$\frac{10 \text{ LBS.}}{10" \times 4"} = 0.25 \text{ P.S.I.}$   
(PACKAGING CODE L5)

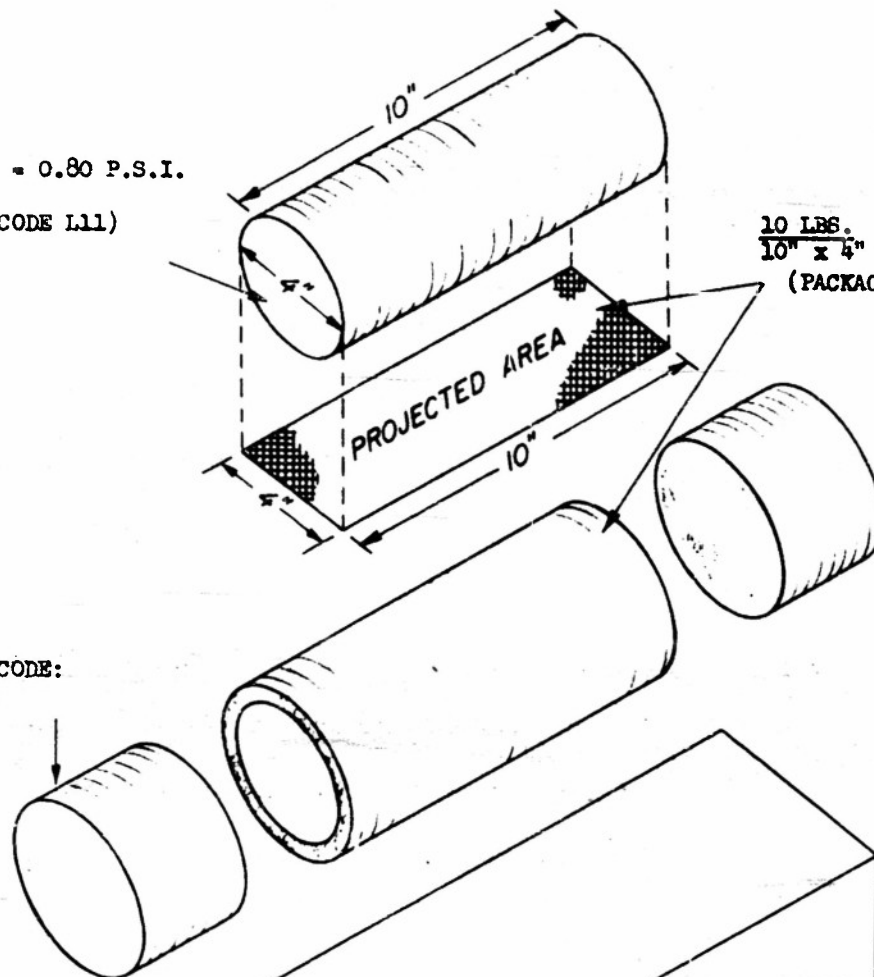

PACKAGING CODE:  
M14-G5-L11

MATERIAL NO. 14 IS  
EASILY WRAPPED AND  
CUSHION USE TABLE NO.  
14 INDICATES 3.25" OF  
CUSHION COMPRESSED TO  
1.75" IS REQUIRED

ALTERNATIVE: CORNERS  
MAY BE FILLED AND  
CYLINDER OR WRAP OMITTED

CORRUGATED OR SOLID  
FIBERBOARD CYLINDER OR WRAP

CLEARANCE FOR  
COMPRESSED CUSHION

Supplement

1. Cushioning Selection Table listing cushioning materials in order of cushion thickness needed for each packaging condition.
2. Cushioning tables indexed by cushioning material and listing cushion thickness required for each packaging condition.

CUSHIONING

PACKAGING CODE	WEIGHT PER UNIT AREA OF ARTICLE					
	L1	L2	L3	L4	L5	L6
	POUNDS PER					
ARTICLE FRAGILITY FACTOR	0.05 THRU 0.09	0.10 THRU 0.14	0.15 THRU 0.19	0.20 THRU 0.24	0.25 THRU 0.29	0.30 THRU 0.34
G1 5 THRU 9						
G2 10 THRU 24	<u>10-27</u> , 3					
G3 25 THRU 49	10, <u>1-21-22</u> , 27, 2, <u>11-15-23</u> , <u>1-8-2</u>	10, 3, 22, <u>21-27</u> , 14	<u>1-10</u>			
G4 50 THRU 74	<u>10-11-22</u> , <u>2-1-21-23</u> , <u>14-27</u> , 9, <u>1-8</u> , <u>4-16-19</u> , <u>7-26</u> , <u>2-18-17-25-30-34</u> , <u>14-26</u>	11, 2, <u>10-1-22</u> , <u>21-23</u> , 14, <u>2-27</u> , <u>5-7</u> , 16	11, <u>1-10</u> , <u>14-22-23</u> , <u>2-21</u> , <u>2-27</u> , 8	11, 10, 3, 23, <u>14-22</u> , <u>2-21</u> , <u>2-27</u>	<u>1-10-11</u> , 23, <u>14-22</u> , <u>2-21</u>	<u>1-10-11</u> , 23, 14, 22
G5 75 THRU 99	11, <u>10-22-23</u> , <u>2-1-21</u> , <u>9-14-27</u> , 1, 8, <u>4-16-19</u> , 30, <u>5-7-12-17</u> , <u>14-26-33</u> , <u>11-20-27</u> , <u>6-14</u> , <u>28-32</u> , <u>18-23</u> , 24	11, <u>2-1-10-22-23</u> , <u>14-21</u> , 9, 27, <u>1-8</u> , <u>16-19</u> , 12, <u>2-7-17-30</u> , <u>11-15</u> , <u>14-26</u> , <u>6-20-25-29</u>	11, <u>1-10-23</u> , <u>2-22</u> , <u>14-21</u> , 9, <u>8-27</u> , 1, 16, <u>4-12-15</u> , 30, <u>2-7-11-17</u> , <u>26-32</u>	11, <u>1-10-23</u> , <u>2-14-22</u> , 21, 9, <u>8-27</u> , 16, <u>1-4-12-19</u> , <u>11-30</u>	11, <u>1-10-23</u> , <u>14-22</u> , <u>2-21</u> , 9, <u>8-27</u> , <u>12-16</u>	11, <u>1-10-23</u> , 14, <u>2-22</u> , 21, 9, <u>8-27</u>
G6 100 THRU 124	11, <u>2-10-21-22-23</u> , <u>1-9-14</u> , <u>1-27</u> , 8, <u>4-16-19</u> , <u>7-12-14-17-30</u> , <u>1-11</u> , <u>11-20-26-28</u> , <u>6-24-25-32</u> , <u>18-24</u> , 24	11, <u>10-23</u> , <u>2-1-21-22</u> , <u>9-14</u> , <u>1-8-27</u> , <u>1-15</u> , <u>12-19</u> , 30, <u>2-11-17</u> , <u>7-17-28-29-31</u> , 26, <u>30-32</u> , 6, <u>18-24-25</u> , 14	11, <u>10-23</u> , <u>2-1-22</u> , <u>14-21</u> , 9, 27, <u>1-8</u> , <u>4-12-16</u> , <u>13-19-28-30</u> , <u>2-27</u> , <u>1-11-15</u> , 15, 26, <u>24-27</u> , <u>6-20</u>	11, <u>10-23</u> , <u>1-22</u> , <u>2-14-21</u> , 9, <u>8-27</u> , 14, <u>12-13-16-19-28-29</u> , <u>30</u> , 3, <u>7-11-15</u> , <u>14-24-26</u>	11, <u>1-10-23</u> , <u>2-14-22</u> , 21, 9, 8, <u>27-28</u> , <u>1-4-12-14-16-29</u> , 19, 30, <u>2-32</u> , <u>1-17</u>	11, <u>1-10-23</u> , 14, <u>2-22</u> , 21, 9, <u>8-28-29</u> , <u>12-13-27</u> , <u>4-16-19</u> , <u>1-30</u> , <u>2-32</u>

MATERIAL NO.	NAME	MATERIAL NO.	NAME	MATERIAL NO.	NAME
1		7		13	
2		8		14	
3		9		15	
4		10		16	
5		11		17	
6		12		18	

NOTE: For each condition materials are listed from thin to thick in order of the thickness required. The required thickness of underlined materials is the same. Values of thickness are found on the Fragility Tables.

SELECTION TABLE (PART I)

L7	L8	L9	L10	L11	L12	L13
TO BE PACKED						
SQUARE INCH						
0.35 THRU 0.39	0.40 THRU 0.44	0.45 THRU 0.54	0.55 THRU 0.64	0.65 THRU 0.84	0.85 THRU 1.04	1.05 THRU 1.25
<u>1-10-11, 14-23</u>	<u>1-10, 11</u>	<u>1-10, 11</u>	<u>1-10</u>			
<u>1-11, 10, 23, 14,</u> <u>2-22, 21, 9</u>	<u>1-10-11, 14-23,</u> <u>2-22, 21</u>	<u>1-10, 11, 14-23,</u> <u>2-22</u>	3, <u>10-11, 14, 23</u>	3, 10, 11, 14	3, 10	3
<u>1-10-11, 23, 14,</u> <u>2-22, 21, 9-28,</u> <u>8-11-29, 12-27,</u> <u>4-16, 19-20</u>	11, <u>1-10, 23, 14,</u> <u>2-22, 21, 9-28-29,</u> <u>8-11, 4-12-27</u>	<u>1-10-11, 14-23,</u> <u>2-22, 26, 21-29,</u> <u>13, 8-9</u>	<u>1-10-11, 14, 23,</u> <u>2-22-26-29, 13-21</u>	<u>1-10-11, 14,</u> <u>21-26-29, 2-22</u>	3, 10, <u>11-14, 28</u>	3, 10, <u>11-14-28</u>

MATERIAL	NAME	MATERIAL	NAME	MATERIAL	NAME
NO.		NO.		NO.	
19		25		32	
20		26		34	
21		27		35	
22		28			
23		29			
24		30			

CUSHIONING

PACKAGING CODE	L1	L2	L3	L4	L5	L6
	WEIGHT PER UNIT AREA OF ARTICLE					
	ARTICLE FRAGILITY FACTOR	POUNDS PER				
	0.05 THRU 0.09	0.10 THRU 0.14	0.15 THRU 0.19	0.20 THRU 0.24	0.25 THRU 0.29	0.30 THRU 0.34
G7	125 THRU 149	11, 2-22-23, 1-3-10-21, 1-14-27, 8-15, 8-12-18-20, 1-12-13-15, 1-16-20, 1-21-22, 16-27-28, 1-29-30, 1-31-32, 1-33-34, 1-35-36, 1-37-38, 1-39-40, 1-41-42, 1-43-44, 1-45-46, 1-47-48, 1-49-50, 1-51-52, 1-53-54, 1-55-56, 1-57-58, 1-59-60, 1-61-62, 1-63-64, 1-65-66, 1-67-68, 1-69-70, 1-71-72, 1-73-74, 1-75-76, 1-77-78, 1-79-80, 1-81-82, 1-83-84, 1-85-86, 1-87-88, 1-89-90, 1-91-92, 1-93-94, 1-95-96, 1-97-98, 1-99-100, 1-101-102, 1-103-104, 1-105-106, 1-107-108, 1-109-110, 1-111-112, 1-113-114, 1-115-116, 1-117-118, 1-119-120, 1-121-122, 1-123-124, 1-125-126, 1-127-128, 1-129-130, 1-131-132, 1-133-134, 1-135-136, 1-137-138, 1-139-140, 1-141-142, 1-143-144, 1-145-146, 1-147-148, 1-149-150, 1-151-152, 1-153-154, 1-155-156, 1-157-158, 1-159-160, 1-161-162, 1-163-164, 1-165-166, 1-167-168, 1-169-170, 1-171-172, 1-173-174, 1-175-176, 1-177-178, 1-179-180, 1-181-182, 1-183-184, 1-185-186, 1-187-188, 1-189-190, 1-191-192, 1-193-194, 1-195-196, 1-197-198, 1-199-200, 1-201-202, 1-203-204, 1-205-206, 1-207-208, 1-209-210, 1-211-212, 1-213-214, 1-215-216, 1-217-218, 1-219-220, 1-221-222, 1-223-224, 1-225-226, 1-227-228, 1-229-230, 1-231-232, 1-233-234, 1-235-236, 1-237-238, 1-239-240, 1-241-242, 1-243-244, 1-245-246, 1-247-248, 1-249-250, 1-251-252, 1-253-254, 1-255-256, 1-257-258, 1-259-260, 1-261-262, 1-263-264, 1-265-266, 1-267-268, 1-269-270, 1-271-272, 1-273-274, 1-275-276, 1-277-278, 1-279-280, 1-281-282, 1-283-284, 1-285-286, 1-287-288, 1-289-290, 1-291-292, 1-293-294, 1-295-296, 1-297-298, 1-299-300, 1-301-302, 1-303-304, 1-305-306, 1-307-308, 1-309-310, 1-311-312, 1-313-314, 1-315-316, 1-317-318, 1-319-320, 1-321-322, 1-323-324, 1-325-326, 1-327-328, 1-329-330, 1-331-332, 1-333-334, 1-335-336, 1-337-338, 1-339-340, 1-341-342, 1-343-344, 1-345-346, 1-347-348, 1-349-350, 1-351-352, 1-353-354, 1-355-356, 1-357-358, 1-359-360, 1-361-362, 1-363-364, 1-365-366, 1-367-368, 1-369-370, 1-371-372, 1-373-374, 1-375-376, 1-377-378, 1-379-380, 1-381-382, 1-383-384, 1-385-386, 1-387-388, 1-389-390, 1-391-392, 1-393-394, 1-395-396, 1-397-398, 1-399-400, 1-401-402, 1-403-404, 1-405-406, 1-407-408, 1-409-410, 1-411-412, 1-413-414, 1-415-416, 1-417-418, 1-419-420, 1-421-422, 1-423-424, 1-425-426, 1-427-428, 1-429-430, 1-431-432, 1-433-434, 1-435-436, 1-437-438, 1-439-440, 1-441-442, 1-443-444, 1-445-446, 1-447-448, 1-449-450, 1-451-452, 1-453-454, 1-455-456, 1-457-458, 1-459-460, 1-461-462, 1-463-464, 1-465-466, 1-467-468, 1-469-470, 1-471-472, 1-473-474, 1-475-476, 1-477-478, 1-479-480, 1-481-482, 1-483-484, 1-485-486, 1-487-488, 1-489-490, 1-491-492, 1-493-494, 1-495-496, 1-497-498, 1-499-500, 1-501-502, 1-503-504, 1-505-506, 1-507-508, 1-509-510, 1-511-512, 1-513-514, 1-515-516, 1-517-518, 1-519-520, 1-521-522, 1-523-524, 1-525-526, 1-527-528, 1-529-530, 1-531-532, 1-533-534, 1-535-536, 1-537-538, 1-539-540, 1-541-542, 1-543-544, 1-545-546, 1-547-548, 1-549-550, 1-551-552, 1-553-554, 1-555-556, 1-557-558, 1-559-560, 1-561-562, 1-563-564, 1-565-566, 1-567-568, 1-569-570, 1-571-572, 1-573-574, 1-575-576, 1-577-578, 1-579-580, 1-581-582, 1-583-584, 1-585-586, 1-587-588, 1-589-590, 1-591-592, 1-593-594, 1-595-596, 1-597-598, 1-599-600, 1-601-602, 1-603-604, 1-605-606, 1-607-608, 1-609-610, 1-611-612, 1-613-614, 1-615-616, 1-617-618, 1-619-620, 1-621-622, 1-623-624, 1-625-626, 1-627-628, 1-629-630, 1-631-632, 1-633-634, 1-635-636, 1-637-638, 1-639-640, 1-641-642, 1-643-644, 1-645-646, 1-647-648, 1-649-650, 1-651-652, 1-653-654, 1-655-656, 1-657-658, 1-659-660, 1-661-662, 1-663-664, 1-665-666, 1-667-668, 1-669-670, 1-671-672, 1-673-674, 1-675-676, 1-677-678, 1-679-680, 1-681-682, 1-683-684, 1-685-686, 1-687-688, 1-689-690, 1-691-692, 1-693-694, 1-695-696, 1-697-698, 1-699-700, 1-701-702, 1-703-704, 1-705-706, 1-707-708, 1-709-710, 1-711-712, 1-713-714, 1-715-716, 1-717-718, 1-719-720, 1-721-722, 1-723-724, 1-725-726, 1-727-728, 1-729-730, 1-731-732, 1-733-734, 1-735-736, 1-737-738, 1-739-740, 1-741-742, 1-743-744, 1-745-746, 1-747-748, 1-749-750, 1-751-752, 1-753-754, 1-755-756, 1-757-758, 1-759-760, 1-761-762, 1-763-764, 1-765-766, 1-767-768, 1-769-770, 1-771-772, 1-773-774, 1-775-776, 1-777-778, 1-779-780, 1-781-782, 1-783-784, 1-785-786, 1-787-788, 1-789-790, 1-791-792, 1-793-794, 1-795-796, 1-797-798, 1-799-800, 1-801-802, 1-803-804, 1-805-806, 1-807-808, 1-809-810, 1-811-812, 1-813-814, 1-815-816, 1-817-818, 1-819-820, 1-821-822, 1-823-824, 1-825-826, 1-827-828, 1-829-830, 1-831-832, 1-833-834, 1-835-836, 1-837-838, 1-839-840, 1-841-842, 1-843-844, 1-845-846, 1-847-848, 1-849-850, 1-851-852, 1-853-854, 1-855-856, 1-857-858, 1-859-860, 1-861-862, 1-863-864, 1-865-866, 1-867-868, 1-869-870, 1-871-872, 1-873-874, 1-875-876, 1-877-878, 1-879-880, 1-881-882, 1-883-884, 1-885-886, 1-887-888, 1-889-890, 1-891-892, 1-893-894, 1-895-896, 1-897-898, 1-899-900, 1-901-902, 1-903-904, 1-905-906, 1-907-908, 1-909-910, 1-911-912, 1-913-914, 1-915-916, 1-917-918, 1-919-920, 1-921-922, 1-923-924, 1-925-926, 1-927-928, 1-929-930, 1-931-932, 1-933-934, 1-935-936, 1-937-938, 1-939-940, 1-941-942, 1-943-944, 1-945-946, 1-947-948, 1-949-950, 1-951-952, 1-953-954, 1-955-956, 1-957-958, 1-959-960, 1-961-962, 1-963-964, 1-965-966, 1-967-968, 1-969-970, 1-971-972, 1-973-974, 1-975-976, 1-977-978, 1-979-980, 1-981-982, 1-983-984, 1-985-986, 1-987-988, 1-989-990, 1-991-992, 1-993-994, 1-995-996, 1-997-998, 1-999-1000, 1-1001-1002, 1-1003-1004, 1-1005-1006, 1-1007-1008, 1-1009-1010, 1-1011-1012, 1-1013-1014, 1-1015-1016, 1-1017-1018, 1-1019-1020, 1-1021-1022, 1-1023-1024, 1-1025-1026, 1-1027-1028, 1-1029-1030, 1-1031-1032, 1-1033-1034, 1-1035-1036, 1-1037-1038, 1-1039-1040, 1-1041-1042, 1-1043-1044, 1-1045-1046, 1-1047-1048, 1-1049-1050, 1-1051-1052, 1-1053-1054, 1-1055-1056, 1-1057-1058, 1-1059-1060, 1-1061-1062, 1-1063-1064, 1-1065-1066, 1-1067-1068, 1-1069-1070, 1-1071-1072, 1-1073-1074, 1-1075-1076, 1-1077-1078, 1-1079-1080, 1-1081-1082, 1-1083-1084, 1-1085-1086, 1-1087-1088, 1-1089-1090, 1-1091-1092, 1-1093-1094, 1-1095-1096, 1-1097-1098, 1-1099-1100, 1-1101-1102, 1-1103-1104, 1-1105-1106, 1-1107-1108, 1-1109-1110, 1-1111-1112, 1-1113-1114, 1-1115-1116, 1-1117-1118, 1-1119-1120, 1-1121-1122, 1-1123-1124, 1-1125-1126, 1-1127-1128, 1-1129-1130, 1-1131-1132, 1-1133-1134, 1-1135-1136, 1-1137-1138, 1-1139-1140, 1-1141-1142, 1-1143-1144, 1-1145-1146, 1-1147-1148, 1-1149-1150, 1-1151-1152, 1-1153-1154, 1-1155-1156, 1-1157-1158, 1-1159-1160, 1-1161-1162, 1-1163-1164, 1-1165-1166, 1-1167-1168, 1-1169-1170, 1-1171-1172, 1-1173-1174, 1-1175-1176, 1-1177-1178, 1-1179-1180, 1-1181-1182, 1-1183-1184, 1-1185-1186, 1-1187-1188, 1-1189-1190, 1-1191-1192, 1-1193-1194, 1-1195-1196, 1-1197-1198, 1-1199-1200, 1-1201-1202, 1-1203-1204, 1-1205-1206, 1-1207-1208, 1-1209-1210, 1-1211-1212, 1-1213-1214, 1-1215-1216, 1-1217-1218, 1-1219-1220, 1-1221-1222, 1-1223-1224, 1-1225-1226, 1-1227-1228, 1-1229-1230, 1-1231-1232, 1-1233-1234, 1-1235-1236, 1-1237-1238, 1-1239-1240, 1-1241-1242, 1-1243-1244, 1-1245-1246, 1-1247-1248, 1-1249-1250, 1-1251-1252, 1-1253-1254, 1-1255-1256, 1-1257-1258, 1-1259-1260, 1-1261-1262, 1-1263-1264, 1-1265-1266, 1-1267-1268, 1-1269-1270, 1-1271-1272, 1-1273-1274, 1-1275-1276, 1-1277-1278, 1-1279-1280, 1-1281-1282, 1-1283-1284, 1-1285-1286, 1-1287-1288, 1-1289-1290, 1-1291-1292, 1-1293-1294, 1-1295-1296, 1-1297-1298, 1-1299-1300, 1-1301-1302, 1-1303-1304, 1-1305-1306, 1-1307-1308, 1-1309-1310, 1-1311-1312, 1-1313-1314, 1-1315-1316, 1-1317-1318, 1-1319-1320, 1-1321-1322, 1-1323-1324, 1-1325-1326, 1-1327-1328, 1-1329-1330, 1-1331-1332, 1-1333-1334, 1-1335-1336, 1-1337-1338, 1-1339-1340, 1-1341-1342, 1-1343-1344, 1-1345-1346, 1-1347-1348, 1-1349-1350, 1-1351-1352, 1-1353-1354, 1-1355-1356, 1-1357-1358, 1-1359-1360, 1-1361-1362, 1-1363-1364, 1-1365-1366, 1-1367-1368, 1-1369-1370, 1-1371-1372, 1-1373-1374, 1-1375-1376, 1-1377-1378, 1-1379-1380, 1-1381-1382, 1-1383-1384, 1-1385-1386, 1-1387-1388, 1-1389-1390, 1-1391-1392, 1-1393-1394, 1-1395-1396, 1-1397-1398, 1-1399-1400, 1-1401-1402, 1-1403-1404, 1-1405-1406, 1-1407-1408, 1-1409-1410, 1-1411-1412, 1-1413-1414, 1-1415-1416, 1-1417-1418, 1-1419-1420, 1-1421-1422, 1-1423-1424, 1-1425-1426, 1-1427-1428, 1-1429-1430, 1-1431-1432, 1-1433-1434, 1-1435-1436, 1-1437-1438, 1-1439-1440, 1-1441-1442, 1-1443-1444, 1-1445-1446, 1-1447-1448, 1-1449-1450, 1-1451-1452, 1-1453-1454, 1-1455-1456, 1-1457-1458, 1-1459-1460, 1-1461-1462, 1-1463-1464, 1-1465-1466, 1-1467-1468, 1-1469-1470, 1-1471-1472, 1-1473-1474, 1-1475-1476, 1-1477-1478, 1-1479-1480, 1-1481-1482, 1-1483-1484, 1-1485-1486, 1-1487-1488, 1-1489-1490, 1-1491-1492, 1-1493-1494, 1-1495-1496, 1-1497-1498, 1-1499-1500, 1-1501-1502, 1-1503-1504, 1-1505-1506, 1-1507-1508, 1-1509-1510, 1-1511-1512, 1-1513-1514, 1-1515-1516, 1-1517-1518, 1-1519-1520, 1-1521-1522, 1-1523-1524, 1-1525-1526, 1-1527-1528, 1-1529-1530, 1-1531-1532, 1-1533-1534, 1-1535-1536, 1-1537-1538, 1-1539-1540, 1-1541-1542, 1-1543-1544, 1-1545-1546, 1-1547-1548, 1-1549-1550, 1-1551-1552, 1-1553-1554, 1-1555-1556, 1-1557-1558, 1-1559-1560, 1-1561-1562, 1-1563-1564, 1-1565-1566, 1-1567-1568, 1-1569-1570, 1-1571-1572, 1-1573-1574, 1-1575-1576, 1-1577-1578, 1-1579-1580, 1-1581-1582, 1-1583-1584, 1-1585-1586, 1-1587-1588, 1-1589-1590, 1-1591-1592, 1-1593-1594, 1-1595-1596, 1-1597-1598, 1-1599-1600, 1-1601-1602, 1-1603-1604, 1-1605-1606, 1-1607-1608, 1-1609-1610, 1-1611-1612, 1-1613-1614, 1-1615-1616, 1-1617-1618, 1-1619-1620, 1-1621-1622, 1-1623-1624, 1-1625-1626, 1-1627-1628, 1-1629-1630, 1-1631-1632, 1-1633-1634, 1-1635-1636, 1-1637-1638, 1-1639-1640, 1-1641-1642, 1-1643-1644, 1-1645-1646, 1-1647-1648, 1-1649-1650, 1-1651-1652, 1-1653-1654, 1-1655-1656, 1-1657-1658, 1-1659-1660, 1-1661-1662, 1-1663-1664, 1-1665-1666, 1-1667-1668, 1-1669-1670, 1-1671-1672, 1-1673-1674, 1-1675-1676, 1-1677-1678, 1-1679-1680, 1-1681-1682, 1-1683-1684, 1-1685-1686, 1-1687-1688, 1-1689-1690, 1-1691-1692, 1-1693-1694, 1-1695-1696, 1-1697-1698, 1-1699-1700, 1-1701-1702, 1-1703-1704, 1-1705-1706, 1-1707-1708, 1-1709-1710, 1-1711-1712, 1-1713-1714, 1-1715-1716, 1-1717-1718, 1-1719-1720, 1-1721-1722, 1-1723-1724, 1-1725-1726, 1-1727-1728, 1-1729-1730, 1-1731-1732, 1-1733-1734, 1-1735-1736, 1-1737-1738, 1-1739-1740, 1-1741-1742, 1-1743-1744, 1-1745-1746, 1-1747-1748, 1-1749-1750, 1-1751-1752, 1-1753-1754, 1-1755-1756, 1-1757-1758, 1-1759-1760, 1-1761-1762, 1-1763-1764, 1-1765-1766, 1-1767-1768, 1-1769-1770, 1-1771-1772, 1-1773-1774, 1-1775-1776, 1-1777-1778, 1-1779-1780, 1-1781-1782, 1-1783-1784, 1-1785-1786, 1-1787-1788, 1-1789-1790, 1-1791-1792, 1-1793-1794, 1-1795-1796, 1-1797-1798, 1-1799-1800, 1-1801-1802, 1-1803-1804, 1-1805-1806, 1-1807-1808, 1-1809-1810, 1-1811-1812, 1-1813-1814, 1-1815-1816, 1-1817-1818, 1-1819-1820, 1-1821-1822, 1-1823-1824, 1-1825-1826, 1-1827-1828, 1-1829-1830, 1-1831-1832, 1-1833-1834, 1-1835-1836, 1-1837-1838, 1-1839-1840, 1-1841-1842, 1-1843-1844, 1-1845-1846, 1-1847-1848, 1-1849-1850, 1-1851-1852, 1-1853-1854, 1-1855-1856, 1-1857-1858, 1-1859-1860, 1-1861-1862, 1-1863-1864, 1-1865-1866, 1-1867-1868, 1-1869-1870, 1-1871-1872, 1-1873-1874, 1-1875-1876, 1-1877-1878, 1-1879-1880, 1-1881-1882, 1-1883-1884, 1-1885-1886, 1-1887-1888, 1-1889-1890, 1-1891-1892, 1-1893-1894, 1-1895-1896, 1-1897-1898, 1-1899-1900, 1-1901-1902, 1-1903-1904, 1-1905-1906, 1-1907-1908, 1-1909-1910, 1-1911-1912, 1-1913-1914, 1-1915-1916, 1-1917-1918, 1-1919-1920, 1-1921-1922, 1-1923-1924, 1-1925-1926, 1-1927-1928, 1-1929-1930, 1-1931-1932, 1-1933-1934, 1-1935-1936, 1-1937-1938, 1-1939-1940, 1-1941-1942, 1-1943-1944, 1-1945-1946, 1-1947-1948, 1-1949-1950, 1-1951-1952, 1-1953-1954, 1-1955-1956, 1-1957-1958, 1-1959-1960, 1-1961-1962, 1-1963-1964, 1-1965-1966, 1-1967-1968, 1-1969-1970, 1-1971-1972, 1-1973-1974, 1-1975-1976, 1-1977-1978, 1-1979-1980, 1-1981-1982, 1-1983-1984, 1-1985-1986, 1-1987-1988, 1-1989-1990, 1-1991-1992, 1-1993-1994, 1-1995-1996, 1-1997-1998, 1-1999-2000, 1-2001-2002, 1-2003-2004, 1-2005-2006, 1-2007-2008, 1-2009-2010, 1-2011-2012, 1-2013-2014, 1-2015-2016, 1-2017-2018, 1-2019-2020, 1-2021-2022, 1-2023-2024, 1-2025-2026, 1-202				



# INSTRUCTION CHART

Packaging code	L1	L2	L3	L4	L5	L6	L7	L8	L9	L10	L11	L12	L13
	UNIT WEIGHT OF ARTICLE TO BE PACKED												
	Pounds per square inch												
Fragility of article	0.05 thru 0.09	0.10 thru 0.14	0.15 thru 0.19	0.20 thru 0.24	0.25 thru 0.29	0.30 thru 0.34	0.35 thru 0.39	0.40 thru 0.44	0.45 thru 0.54	0.55 thru 0.64	0.65 thru 0.84	0.85 thru 0.104	0.105 thru 1.25
G-value													
G-1	5-9												
G-2	10-24												
G-3	25-49												
G-4	50-74	4.00 thru 5.75	5.00 thru 4.25										
G-5	75-99	2.75 thru 2.80	3.50 thru 3.00	4.00 thru 3.25	4.50 thru 3.50	5.00 thru 3.75							
G-6	100-124	2.25 thru 2.00	2.75 thru 2.25	3.25 thru 2.75	3.75 thru 2.75	4.00 thru 2.75	4.50 thru 3.00	4.75 thru 3.25					
G-7	125-149	1.75 thru 1.50	2.25 thru 2.00	2.75 thru 2.25	3.00 thru 2.25	3.25 thru 2.25	3.50 thru 2.25	4.00 thru 2.50	4.50 thru 2.50	5.00 thru 2.50			
G-8	150-199	1.50 thru 1.25	2.00 thru 1.75	2.25 thru 1.75	2.50 thru 1.75	2.75 thru 1.75	3.00 thru 2.00	3.25 thru 2.00	3.50 thru 2.00	4.00 thru 2.00	4.25 thru 2.00	5.00 thru 2.00	
G-9	200-249	1.25 thru 1.00	1.50 thru 1.25	2.00 thru 1.50	2.25 thru 1.50	2.50 thru 1.50	2.80 thru 1.50	3.00 thru 1.50	3.25 thru 1.50	3.50 thru 1.50	3.75 thru 1.50	4.25 thru 1.50	4.75 thru 1.75
G-10	250-299	1.00	1.25		1.75 thru 1.25	2.00 thru 1.25	2.25 thru 1.25	2.50 thru 1.25					
G-11	300-350	1.00	1.00	1.50 thru 1.00	1.75 thru 1.00	2.00 thru 1.00	2.25 thru 1.00	2.50 thru 1.00	2.75 thru 1.00	3.00 thru 1.00	3.50 thru 1.00	4.00 thru 1.00	4.50 thru 1.00

(1) Packaging Code

G-5 designates the fragility classification of the article to be packed; L6 designates the unit weight of the article. The illustration shown is for an article having a g-value of 75-99 with a total weight and bearing area such that the unit weight (pounds per square inch) is between 0.20 and 0.24 pound.

(2) Cushion Thickness

A 4-inch thickness of cushion material No. 16 is required to provide the necessary protection for the article described by packaging code G-4/L1.

(2a) Compression

To prevent looseness within the pack during shipment and storage, the 4-inch thickness of material No. 16 needs to be compressed to approximately 3.75 inches when packing the G-4/L1 articles.

(3) Packaging Condition

The thickness of cushioning material No. 16 and the compressed thickness are applicable for articles in the G-11 fragility classification having a unit weight range within the limits of L5 through L6.

(4) Limitation of Hand Compression

The percent value represents the approximate amount a material can be compressed by hand. Compression values of 50 percent or less are shown to the left of the heavy dividing line. When the specified compressed thickness, as shown to the right of the heavy division line, cannot be attained by hand, the material shall be compressed by the percentage shown. (Hand compression will vary with the person packing, time and care taken in packing, type of container used, size and shape of articles packed, and thickness and shape of cushion used.)

(5) Some specified values of compression may be 50 percent, as shown at No. 5, or greater. Unless mechanical means are provided for attaining the compressed values, the material shall be compressed as much as possible by hand.

**CAUTION:** Do not compress cushion more than indicated in the tables.

Material No. 1

Packaging code	L1	L2	L3	L4	L5	L6	L7	L8	L9	L10	L11	L12	L13
	UNIT WEIGHT OF ARTICLE TO BE PACKED												
<u>Pounds per square inch</u>													
Fragility of article	0.05 thru 0.09	0.10 thru 0.14	0.15 thru 0.19	0.20 thru 0.24	0.25 thru 0.29	0.30 thru 0.34	0.35 thru 0.39	0.40 thru 0.44	0.45 thru 0.54	0.55 thru 0.64	0.65 thru 0.84	0.85 thru 1.04	1.05 thru 1.25
G-value													
0-1 5-9													
0-2 10-24													
0-3 25-49	5.00												
0-4 50-74	3.25	4.25											
0-5 75-99	2.25	3.00	3.75	4.75									
0-6 100-124	1.75	2.50	3.00	3.50	4.00	4.75							
0-7 125-149	1.50	2.00	2.50	3.00	3.50	4.00	4.25	4.75					
0-8 150-199	1.25	1.75	2.00	2.50	3.00	3.25	3.75	4.00	4.75				
0-9 200-249	1.00		1.75	2.00	2.25	2.50	2.75	3.25	3.75	4.25	5.00		
0-10 250-299		1.25	1.50	1.75	2.00	2.25	2.50	2.50	3.00	3.50	4.25	5.00	
0-11 300-350	.75	1.00	1.25	1.50	1.75	2.00	2.00	2.25	2.50	3.00	3.50	4.00	5.00

NOT SUITABLE FOR USE AT LOW TEMPERATURES

Material No.

2

Packaging code	L1	L2	L3	L4	L5	L6	L7	L8	L9	L10	L11	L12	L13
	UNIT WEIGHT OF ARTICLE TO BE PACKED												
	Pounds per square inch												
Fragility of article	0.05 thru 0.09	0.10 thru 0.14	0.15 thru 0.19	0.20 thru 0.24	0.25 thru 0.29	0.30 thru 0.34	0.35 thru 0.39	0.40 thru 0.44	0.45 thru 0.54	0.55 thru 0.64	0.65 thru 0.84	0.85 thru 1.04	1.05 thru 1.25
G-value													
0-1													
0-2													
0-3	4.25												
0-4	2.25	2.50	3.75	4.25	5.00								
0-5	1.75	2.00	2.50	3.00	3.50	3.75	4.00	4.50	5.00				
0-6	1.25	1.75	2.00	2.50	2.75	3.00	3.25	3.50	4.00	4.50	5.00		
0-7	1.00	1.50	1.75	2.00	2.25	2.50	2.75	3.00	3.25	3.75	4.25	5.00	
0-8	1.00	1.25	1.50	1.75	2.00	2.00	2.25	2.50	2.75	3.00	3.75	4.25	4.75
0-9		1.00	1.25	1.50	1.50	1.75	1.75	2.00	2.25	2.50	3.00	3.50	3.75
0-10		.75	1.00		1.25	1.50	1.50	1.75	2.00	2.00	2.50	2.75	3.00
0-11	.50			1.00	1.25			1.50	1.50	1.75	2.00	2.50	2.75

NOT SUITABLE FOR USE AT LOW TEMPERATURES

Material No. 3

Packaging code	L1	L2	L3	L4	L5	L6	L7	L8	L9	L10	L11	L12	L13
	UNIT WEIGHT OF ARTICLE TO BE PACKED												
Pounds per square inch													
Fragility of article	0.05 thru 0.09	0.10 thru 0.14	0.15 thru 0.19	0.20 thru 0.24	0.25 thru 0.29	0.30 thru 0.34	0.35 thru 0.39	0.40 thru 0.44	0.45 thru 0.54	0.55 thru 0.64	0.65 thru 0.84	0.85 thru 1.04	1.05 thru 1.25
<u>Q-value</u>													
0-1 5-9													
0-2 10-24	5.50												
0-3 25-49	3.50	4.25	4.75										
0-4 50-74	2.25	2.75	3.00	3.50	3.75	4.00	4.25	4.75	5.00				
0-5 75-99	1.75	2.00	2.25	2.50	2.75	3.00	3.25	3.50	3.75	4.25	4.50	5.00	
0-6 100-124	1.50	1.75	2.00	2.25	2.50	2.75	3.00	3.25	3.50	3.75	4.00		
0-7 125-149	1.25	1.50		1.75	2.00	2.25	2.50	2.75	3.00	3.25	3.50		
0-8 150-199			1.50	1.75	2.00	2.25	2.50	2.75	3.00	3.25	3.50		
0-9 200-249	1.00	1.25			1.50	1.75	2.00	2.25	2.50	2.75	3.00	3.25	
0-10 250-299							1.75	2.00	2.25	2.50	2.75	3.00	3.25
0-11 300-350	.75		1.00	1.25	1.50	1.75	2.00	2.25	2.50	2.75	3.00	3.25	3.50

4 90096 7

NOT SUITABLE FOR USE AT LOW TEMPERATURES

Packaging code	L1	L2	L3	L4	L5	L6	L7	L8	L9	L10	L11	L12	L13
	UNIT WEIGHT OF ARTICLE TO BE PACKED												
Fragility of article	Pounds per square inch												
	0.05 thru 0.09	0.10 thru 0.14	0.15 thru 0.19	0.20 thru 0.24	0.25 thru 0.29	0.30 thru 0.34	0.35 thru 0.39	0.40 thru 0.44	0.45 thru 0.54	0.55 thru 0.64	0.65 thru 0.84	0.85 thru 1.04	1.05 thru 1.25
0-1													
0-2													
0-3													
0-4	4.00												
0-5	2.75	3.50	4.25	4.75									
0-6	2.25	2.75	3.25	3.50	4.00	4.50	4.75	5.00					
0-7	1.75	2.00	2.25	2.00	2.25	2.00	2.00	2.00	4.75	5.00			
0-8	1.50	1.50	1.50	1.75	1.75	1.75	1.75	1.75	2.00	2.00	5.00		
0-9	1.25	1.75	2.00	2.75	2.25	2.50	2.75	3.00	3.25	3.50	4.00	4.25	5.00
0-10	1.00	1.25	1.50	1.75	1.00	1.25	1.50	1.50	1.25	1.50	1.50	1.50	1.75
0-11	1.00	1.25	1.50	1.75	1.00	1.25	1.50	1.50	2.25	2.50	3.25	3.75	4.00
	1.00	1.25	1.50	1.75	1.00	1.25	1.50	1.50	2.25	2.50	2.75	3.25	3.90
	1.00	1.00	1.00	1.00	1.00	1.00	1.00	1.00	1.00	1.00	1.00	1.25	1.25

607

Material No. 5

Packaging code	L1	L2	L3	L4	L5	L6	L7	L8	L9	L10	L11	L12	L13
	UNIT WEIGHT OF ARTICLE TO BE PACKED												
Fragility of article	Pounds per square inch												
	0.05 thru 0.09	0.10 thru 0.14	0.15 thru 0.19	0.20 thru 0.24	0.25 thru 0.29	0.30 thru 0.34	0.35 thru 0.39	0.40 thru 0.44	0.45 thru 0.54	0.55 thru 0.64	0.65 thru 0.84	0.85 thru 1.04	1.05 thru 1.25
0-1													
0-2													
0-3													
0-4	4.50 3.25												
0-5	3.25 2.50	4.00 2.50	4.75 2.75										
0-6	2.50 2.00	3.25 2.00	3.75 2.25	4.25 2.25	4.75 2.50	5.00 2.50							
0-7	2.25 1.75	2.75 1.75	3.00 1.75	3.50 2.00	3.75 2.00	4.00 2.00	4.25 2.00	4.75 2.00	5.00 2.00				
0-8	2.00 1.50	2.00 1.50	2.75 1.75	3.00 1.75	3.25 1.75	3.50 1.75	3.75 1.75	4.00 1.75	4.50 2.00	5.00 2.00			
0-9	1.50 1.25	1.75 1.25	2.25 1.50	2.50 1.50	2.75 1.50	3.00 1.50	3.25 1.50	3.50 1.50	3.75 1.50	4.00 1.50	4.50 1.25	5.00 1.75	
0-10	1.25 1.00	1.25 1.00	1.75 1.00	2.00 1.00	2.25 1.25	2.50 1.25	2.75 1.25	3.00 1.25	3.25 1.25	3.50 1.25	3.75 1.25	4.00 1.25	4.50 1.25
0-11	1.00	1.00	1.00	1.00	1.00	1.00	1.00	1.00	1.00	1.00	1.25	1.25	1.25

608

Packaging code	L1	L2	L3	L4	L5	L6	L7	L8	L9	L10	L11	L12	L13
	UNIT WEIGHT OF ARTICLE TO BE PACKED												
<u>Pounds per square inch</u>													
Fragility of article	0.05 thru 0.09	0.10 thru 0.14	0.15 thru 0.19	0.20 thru 0.24	0.25 thru 0.29	0.30 thru 0.34	0.35 thru 0.39	0.40 thru 0.44	0.45 thru 0.54	0.55 thru 0.64	0.65 thru 0.84	0.85 thru 1.04	1.05 thru 1.25
<u>Q-value</u>													
0-1	5-9												
0-2	10-24												
0-3	25-49												
0-4	50-74												
0-5	75-99	4.00	5.00										
0-6	100-124	3.00	3.25	5.00									
0-7	125-149	3.25	4.25	2.50									
0-8	150-199	2.25	2.50	4.25	4.75								
0-9	200-249	2.75	3.50	2.25	2.25	4.25							
0-10	250-299	2.00	2.00	3.75	4.25	5.00	4.75	5.00					
0-11	300-350	1.75	1.75	2.00	2.00	1.75	2.00	1.75	4.75	5.00			
		2.00	2.50	3.00	3.50	4.00	4.50	4.75	5.00				
		1.25	1.50	1.50	1.50	1.50	1.50	1.50	1.50	5.00			
		1.75	2.25	2.50	2.75	3.50	3.75	4.00	4.50	5.00			
		1.00	1.25	1.25	1.25	1.25	1.25	1.25	1.25	1.25			
		1.50	1.75	2.25	2.50	3.00	3.25	3.50	4.00	4.25	5.00		
		1.00	1.00	1.00	1.00	1.00	1.00	1.00	1.00	1.00	1.00		

507

Material No. 7

Packaging code	L1	L2	L3	L4	L5	L6	L7	L8	L9	L10	L11	L12	L13
	UNIT WEIGHT OF ARTICLE TO BE PACKED												
Fragility of article	Pounds per square inch												
	0-05 thru 0-09	0-10 thru 0-14	0-15 thru 0-19	0-20 thru 0-24	0-25 thru 0-29	0-30 thru 0-34	0-35 thru 0-39	0-40 thru 0-44	0-45 thru 0-54	0-55 thru 0-64	0-65 thru 0-84	0-85 thru 1-04	1-05 thru 1-25
0-1													
0-2													
0-3													
0-4	4.25 4.00												
0-5	3.25 3.00	4.00 3.50	4.75 4.00										
0-6	2.75 2.50	3.50 3.25	4.00 3.50	4.50 3.75	5.00 4.25								
0-7	2.50 2.50	3.00 2.75	3.50 3.00	4.00 3.50	4.25 3.50	4.75 4.00							
0-8	2.25 2.25	2.75 2.50	3.25 3.00	3.50 3.00	4.00 3.50	4.25 3.50	4.50 3.50	4.75 3.75					
0-9	1.75 1.75	2.25 2.00	2.75 2.50	3.00 2.50	3.25 2.50	3.50 2.50	3.75 2.50	4.00 2.50	4.50 2.50	5.00 2.50			
0-10	1.50	2.00	2.25	2.75	3.00	3.25	3.50	3.75	4.00	4.50	5.00		
0-11	1.50	1.75	2.00	2.50	2.75	3.00	3.25	3.50	3.75	4.00	4.50	5.00	
		1.50	1.75	2.00	2.25	2.50	2.75	3.00	3.25	3.50	4.00	4.50	5.00
		1.50	1.75	2.00	2.25	2.50	2.75	3.00	3.25	3.50	4.00	4.50	5.00

50%

NOT SUITABLE FOR USE AT LOW TEMPERATURES

Packaging code	L1	L2	L3	L4	L5	L6	L7	L8	L9	L10	L11	L12	L13
	UNIT WEIGHT OF ARTICLE TO BE PACKED												
Pounds per square inch													
Fragility of article	0.05 thru 0.09	0.10 thru 0.14	0.15 thru 0.19	0.20 thru 0.24	0.25 thru 0.29	0.30 thru 0.34	0.35 thru 0.39	0.40 thru 0.44	0.45 thru 0.54	0.55 thru 0.64	0.65 thru 0.84	0.85 thru 1.04	1.05 thru 1.25
0-1													
0-2													
0-3	5.00												
0-4	3.25	4.25	5.00										
0-5	3.25	4.00	4.50										
0-6	2.50	3.00	3.50	4.00	4.50	5.00							
0-7	2.50	3.00	3.25	3.50	3.75	4.00	4.25	4.50	5.00				
0-8	2.00	2.50	3.00	3.25	3.50	4.00	4.25	4.50	5.00				
0-9	2.00	2.50	2.75	3.00	3.00	3.25	3.25	3.25	3.25				
0-10	1.75	2.00	2.50	2.75	3.00	3.25	3.50	3.75	4.25	4.75			
0-11	1.75	2.00	2.25	2.50	2.75	2.75	2.75	2.75	2.75	2.75			
	1.50	1.75	2.25	2.50	2.75	3.00	3.00	3.25	3.75	4.00	4.75		
	1.50	1.75	2.00	2.25	2.50	2.50	2.50	2.25	2.50	2.25	2.50		
	1.25	1.50	1.75	2.00	2.25	2.25	2.50	2.75	3.00	3.25	3.75	4.25	4.75
	1.25	1.50	1.50	1.75	2.00	2.00	2.00	2.00	2.00	2.00	2.00	2.00	2.00
	1.00	1.25	1.50	1.50	1.75	2.00	2.25	2.25	2.50	2.75	3.25	3.50	4.00
	1.00	1.25	1.25	1.50	1.75	1.75	2.00	2.00	2.25	2.50	2.75	3.00	3.50

406

NOT SUITABLE FOR USE AT LOW TEMPERATURES

Packaging code	L1	L2	L3	L4	L5	L6	L7	L8	L9	L10	L11	L12	L13
	UNIT WEIGHT OF ARTICLE TO BE PACKED												
Pounds per square inch													
Fragility of article	0.05 thru 0.09	0.10 thru 0.14	0.15 thru 0.19	0.20 thru 0.24	0.25 thru 0.29	0.30 thru 0.34	0.35 thru 0.39	0.40 thru 0.44	0.45 thru 0.54	0.55 thru 0.64	0.65 thru 0.84	0.85 thru 1.04	1.05 thru 1.25
0-value													
0-1	5-9												
0-2	10-24												
0-3	25-49	5.00											
0-4	50-74	2.75	3.50	4.25	5.00								
0-5	75-99	2.00	2.50	3.25	3.75	4.50	5.00						
0-6	100-124	1.50	2.00	2.50	3.00	3.75	4.00	4.25	5.00				
0-7	125-149	1.25	1.75	2.25	2.50	3.00	3.25	3.50	4.00	4.50	5.00		
0-8	150-199	1.00	1.50	1.75	2.25	2.75	3.00	3.50	3.50	4.00	4.75	5.00	
0-9	200-249	1.00	1.25	1.50	1.75	2.00	2.25	2.50	3.00	3.25	3.75	4.25	5.00
0-10	250-299				1.50		2.00	2.25	2.50	2.75	3.25	3.50	4.00
0-11	300-350	.75	1.00	1.50	1.25	1.50	1.75	2.00	2.50	2.50	2.75	3.25	3.50

NOT SUITABLE FOR USE AT LOW TEMPERATURES

Packaging code	L11	L12	L13	L14	L15	L16	L17	L18	L19	L10	L11	L12	L13
	UNIT WEIGHT OF ARTICLE TO BE PACKED												
Pounds per square inch													
Fragility of article	0.05 thru 0.09	0.10 thru 0.14	0.15 thru 0.19	0.20 thru 0.24	0.25 thru 0.29	0.30 thru 0.34	0.35 thru 0.39	0.40 thru 0.44	0.45 thru 0.54	0.55 thru 0.64	0.65 thru 0.84	0.85 thru 1.04	1.05 thru 1.25
0-value													
0-1 5-9													
0-2 10-24	5.00												
0-3 25-49	3.25	4.00	4.75										
0-4 50-74	2.00	2.75	3.00	3.25	3.50	3.75	4.00	4.25	4.75	5.00			
0-5 75-99	1.50	2.00	2.25	2.50	2.75	3.00	3.25	3.50	3.50	4.00	4.50	5.00	
0-6 100-124	1.25	1.50		2.00	2.25	2.50	2.50	2.75	3.00	3.25	3.75	4.25	4.50
0-7 125-149			1.75		2.00	2.00	2.25	2.25	2.50	2.75	3.25	3.50	3.75
0-8 150-199	1.00	1.25	1.50		1.75	1.75	2.00	2.00	2.25	2.50	2.75	3.00	3.50
0-9 200-249					1.50	1.50	1.75	1.75	2.00	2.00	2.25	2.50	2.75
0-10 250-299						1.25	1.50	1.50	1.75	1.75	2.00	2.00	2.25
0-11 300-350	.75		1.00						1.50	1.50	1.75	2.00	2.25

NOT SUITABLE FOR USE AT LOW TEMPERATURES

Packaging code	L1	L2	L3	L4	L5	L6	L7	L8	L9	L10	L11	L12	L13
	UNIT WEIGHT ARTICLE TO BE PACKED												
Pounds per square inch													
Fragility of article	0.05 thru 0.09	0.10 thru 0.14	0.15 thru 0.19	0.20 thru 0.24	0.25 thru 0.29	0.30 thru 0.34	0.35 thru 0.39	0.40 thru 0.44	0.45 thru 0.54	0.55 thru 0.64	0.65 thru 0.84	0.85 thru 1.04	1.05 thru 1.25
<u>G-value</u>													
0-1 5-9													
0-2 10-24													
0-3 25-49	4.50												
0-4 50-74	2.00	2.25	2.75	3.00	3.50	3.75	4.00	4.50	5.00				
0-5 75-99	1.25	1.50	2.00	2.25	2.50	2.75	3.00	3.25	3.75	4.00	4.75		
0-6 100-124	1.00	1.25	1.50	1.75	2.00	2.25		3.00	3.00	3.25	3.75	4.50	5.00
0-7 125-149		2.00		1.50	1.75		2.00	2.25	2.50	2.75	3.25	3.75	4.00
0-8 150-199			1.25		1.50		1.75	2.00	2.25	2.50	2.75	3.25	3.50
0-9 200-249							1.50		1.75	2.00	2.25	2.50	2.75
0-10 250-299					1.00			1.25			2.00	2.25	2.50
0-11 300-350											1.75		2.0

NOT SUITABLE FOR USE AT LOW TEMPERATURES

Packaging code	L1	L2	L3	L4	L5	L6	L7	L8	L9	L10	L11	L12	L13
	UNIT WEIGHT OF ARTICLE TO BE PACKED												
	Pounds per square inch												
Fragility of article	0.05 thru 0.09	0.10 thru 0.14	0.15 thru 0.19	0.20 thru 0.24	0.25 thru 0.29	0.30 thru 0.34	0.35 thru 0.39	0.40 thru 0.44	0.45 thru 0.54	0.55 thru 0.64	0.65 thru 0.84	0.85 thru 1.04	1.05 thru 1.25
Q-value													
0-1	5-9												
0-2	10-24												
0-3	25-49												
0-4	50-74	4.50 4.00											
0-5	75-99	3.25 2.75	3.75 3.00	4.25 3.50	4.75 3.75	5.00 3.50							
0-6	100-124	2.50 2.25	3.00 2.50	3.25 2.50	3.75 2.75	4.00 2.75	4.50 2.75	5.00 2.75					
0-7	125-149	2.00 1.75	2.50 2.00	2.75 2.25	3.00 2.25	3.50 2.25	3.75 2.25	4.00 2.25	4.25 2.25	4.50 2.25	5.00 2.25		
0-8	150-199	1.75 1.50	2.00 1.75	2.25 1.75	2.50 1.75	3.00 1.75	3.00 1.75	3.75 1.75	4.25 1.75	4.50 1.75	5.00 1.75		
0-9	200-249	1.00 1.25	1.25 1.25	1.50 1.25	2.00 1.25	2.25 1.25	2.50 1.25	3.00 1.25	3.50 1.25	4.00 1.25	4.50 1.25	5.00 1.25	
0-10	250-299		1.25	1.00	1.25	1.25	1.25	1.25	1.25	1.25	1.25	1.25	1.25
0-11	300-350	1.00 1.00	1.00	1.00	1.00	1.00	1.00	1.00	1.00	1.00	1.00	1.00	1.00

Packaging code	L1	L2	L3	L4	L5	L6	L7	L8	L9	L10	L11	L12	L13
	UNIT WEIGHT OF ARTICLE TO BE PACKED												
Fragility of article	Pounds per square inch												
	0.05 thru 0.09	0.10 thru 0.14	0.15 thru 0.19	0.20 thru 0.24	0.25 thru 0.29	0.30 thru 0.34	0.35 thru 0.39	0.40 thru 0.44	0.45 thru 0.54	0.55 thru 0.64	0.65 thru 0.84	0.85 thru 1.04	1.05 thru 1.25
0-1													
0-2													
0-3													
0-4													
0-5	3.75	4.25	4.75	5.00									
0-6	3.00	3.25	3.25	3.25	4.00	4.25	4.25	4.50	4.75	5.00			
0-7	2.25	2.25	2.50	2.50	2.75	2.75	2.75	2.75	2.75	2.75	4.25	4.50	4.75
0-8	2.25	2.75	3.00	3.00	3.25	3.25	3.25	3.25	3.25	3.50	3.75	4.00	4.25
0-9	1.75	2.00	2.25	2.50	2.25	2.25	2.25	2.25	2.25	2.50	2.50	2.50	2.50
0-10	2.00	2.25	2.25	2.25	2.75	3.00	3.00	3.00	3.25	3.50	3.75	4.00	4.25
0-11	1.50	1.75	1.75	1.75	1.75	1.75	1.75	1.75	2.00	2.00	2.00	2.00	2.25
	1.50	1.75	2.00	2.00	2.25	2.25	2.25	2.50	2.50	2.75	2.75	3.00	3.25
	1.25	1.25	1.25	1.25	1.50	1.50	1.50	1.50	1.50	1.50	1.50	1.50	1.50
	1.25	1.25	1.25	1.25	1.75	1.75	1.75	2.00	2.00	2.25	2.25	2.25	2.50
	1.00	1.00	1.00	1.00	1.25	1.25	1.25	1.25	1.25	1.25	1.25	1.25	1.50
	1.00	1.00	1.00	1.00	1.50	1.50	1.50	1.75	1.75	2.00	2.00	2.00	2.25
	1.00	1.00	1.00	1.00	1.00	1.00	1.00	1.00	1.00	1.00	1.00	1.00	1.25

Packaging code	L1	L2	L3	L4	L5	L6	L7	L8	L9	L10	L11	L12	L13
	UNIT WEIGHT OF ARTICLE TO BE PACKED												
	Pounds per square inch												
Fragility of article	0.05 thru 0.09	0.10 thru 0.14	0.15 thru 0.19	0.20 thru 0.24	0.25 thru 0.29	0.30 thru 0.34	0.35 thru 0.39	0.40 thru 0.44	0.45 thru 0.54	0.55 thru 0.64	0.65 thru 0.84	0.85 thru 1.04	1.05 thru 1.25
0-1													
0-2													
0-3	4.50 3.25	5.25 3.25											
0-4	2.50 1.75	3.25 2.00	3.50 2.00	4.00 2.25	4.50 2.25	4.75 2.50	5.00 2.50						
0-5	2.00 1.50	2.25 1.50	2.75 1.75	3.00 1.75	3.25 1.75	3.50 1.75	3.75 1.75	4.25 1.75	4.25 1.75	4.50 2.00	5.00 2.00		
0-6	1.50 1.25	2.00 1.25	2.25 1.25	2.50 1.25	2.75 1.50	3.00 1.50	3.00 1.50	3.25 1.50	3.50 1.50	3.75 1.50	4.25 1.50	4.50 1.50	5.00 1.50
0-7	1.25 1.00	1.75 1.25	2.00 1.25	2.00 1.25	2.25 1.25	2.50 1.25	2.50 1.25	2.75 1.25	3.00 1.25	3.25 1.25	3.50 1.25	3.75 1.25	4.25 1.25
0-8	1.25 1.00	1.50 1.00	1.75 1.00	1.75 1.00	2.00 1.00	2.25 1.00	2.25 1.00	2.50 1.25	2.75 1.00	3.00 1.00	3.00 1.00	3.50 1.00	
0-9		1.25 1.00	1.50 1.00	1.50 1.00	1.75 1.00	1.75 1.00	2.00 1.00	2.00 1.00		2.25 1.00	2.50 1.00	2.75 1.00	3.00 1.00
0-10		1.00	1.25	1.25	1.50	1.50	1.50	1.75	1.75	2.00	2.00	2.25	2.50
0-11	.75 .75	.75 .75	.75	.75	.75	.75	.75	.75	.75	.75	2.00 .75	2.00 .75	2.25 .75

Packaging code	L1	L2	L3	L4	L5	L6	L7	L8	L9	L10	L11	L12	L13
	UNIT WEIGHT OF ARTICLE TO BE PACKED												
Fragility of article	Pounds per square inch												
	0.05 thru 0.09	0.10 thru 0.14	0.15 thru 0.19	0.20 thru 0.24	0.25 thru 0.29	0.30 thru 0.34	0.35 thru 0.39	0.40 thru 0.44	0.45 thru 0.54	0.55 thru 0.64	0.65 thru 0.84	0.85 thru 1.04	1.05 thru 1.25
0-1													
0-2													
0-3													
0-4	5.00												
0-5	3.75	4.50											
0-6	3.50	3.00											
0-7	2.75	3.50	4.25	5.00	4.50	5.00							
0-8	2.50	2.25	2.50	4.00	2.25	2.50							
0-9	1.75	2.75	3.00	3.50	3.75	4.25	4.50	5.00					
0-10	2.00	1.75	1.75	1.75	1.75	2.00	2.00	2.00					
0-11	1.50	2.00	2.25	2.50	3.00	3.25	3.50	3.75	4.25	4.75			
	1.25	1.25	1.25	1.25	1.25	1.50	1.50	1.50	1.50	1.50			
	1.25	1.50	2.00	2.25	2.50	2.75	3.00	3.50	3.50	3.75	4.50	5.00	
	1.00	1.00	1.25	1.25	1.25	1.25	1.25	1.25	1.25	1.25	1.25	1.25	
	1.00	1.25	1.50	1.75	2.00	2.25	2.50	2.75	3.00	3.25	3.75	4.25	5.00
	.75	.75	.75	1.00	1.00	1.00	1.00	1.00	1.00	1.00	1.00	1.00	1.00



Packaging code	L1	L2	L3	L4	L5	L6	L7	L8	L9	L10	L11	L12	L13
	UNIT WEIGHT OF ARTICLE TO BE PACKED												
	Pounds per square inch												
Fragility of article	0.05 thru 0.09	0.10 thru 0.14	0.15 thru 0.19	0.20 thru 0.24	0.25 thru 0.29	0.30 thru 0.34	0.35 thru 0.39	0.40 thru 0.44	0.45 thru 0.54	0.55 thru 0.64	0.65 thru 0.84	0.85 thru 1.04	1.05 thru 1.25
<u>Q-value</u>													
0-1 5-9													
0-2 10-24													
0-3 25-49													
0-4 50-74	4.50 3.25												
0-5 75-99	3.25 2.50	4.00 3.00	4.75 3.00										
0-6 100-124	2.50 2.00	3.25 2.25	4.00 2.50	4.50 2.50	5.00 2.50								
0-7 125-149	2.25 1.75	2.75 2.00	3.25 2.00	3.75 2.00	4.25 2.00	4.50 2.00	4.75 2.00						
0-8 150-199	2.00 1.50	2.25 1.50	2.75 1.50	3.25 1.75	3.50 1.75	4.00 1.75	4.25 1.75	4.50 1.75	5.00 1.75				
0-9 200-249	1.50 1.25	2.00 1.25	2.25 1.25	2.50 1.25	3.00 1.25	3.25 1.25	3.50 1.50	3.75 1.50	4.00 1.50	4.50 1.50	5.00 1.50		
0-10 250-299	1.00 1.00	1.75 1.00	2.00 1.00	2.25 1.00	2.50 1.00	2.75 1.00	3.00 1.00	3.50 1.00	4.00 1.00	4.50 1.00	5.00 1.00		
0-11 300-350	1.00 1.00	1.50 1.00	1.75 1.00	2.00 1.00	2.25 1.00	2.50 1.00	2.75 1.00	3.00 1.00	3.25 1.00	3.50 1.00	4.00 1.00	4.50 1.00	5.00 1.00

Packaging code	L1	L2	L3	L4	L5	L6	L7	L8	L9	L10	L11	L12	L13
	UNIT WEIGHT OF ARTICLE TO BE PACKED												
Pounds per square inch													
Fragility of article	0.05 thru 0.09	0.10 thru 0.14	0.15 thru 0.19	0.20 thru 0.24	0.25 thru 0.29	0.30 thru 0.34	0.35 thru 0.39	0.40 thru 0.44	0.45 thru 0.54	0.55 thru 0.64	0.65 thru 0.84	0.85 thru 1.04	1.05 thru 1.25
0-1													
0-2													
0-3													
0-4													
0-5	4.50 2.50												
0-6	3.50 2.00	4.50 2.00											
0-7	3.00 1.75	3.75 1.75	4.50 2.00										
0-8	2.50 1.25	3.25 1.50	4.00 1.75	4.75 1.75									
0-9	2.00 1.25	2.75 1.25	3.25 1.50	3.75 1.50	4.25 1.50	4.50 1.50	5.00 1.50						
0-10	1.75 1.00	2.25 1.00	2.75 1.00	3.00 1.00	3.50 1.00	3.75 1.00	4.50 1.00	5.00 1.25					
0-11	1.50 1.00	2.00 1.00	2.50 1.00	2.75 1.00	3.00 1.00	3.25 1.00	3.75 1.00	4.00 1.00	4.50 1.00	4.75 1.00			

606

Packaging code	L1	L2	L3	L4	L5	L6	L7	L8	L9	L10	L11	L12	L13
	UNIT WEIGHT OF ARTICLE TO BE PACKED												
Pounds per square inch													
Fragility of article	0.05 thru 0.09	0.10 thru 0.14	0.15 thru 0.19	0.20 thru 0.24	0.25 thru 0.29	0.30 thru 0.34	0.35 thru 0.39	0.40 thru 0.44	0.45 thru 0.54	0.55 thru 0.64	0.65 thru 0.84	0.85 thru 1.04	1.05 thru 1.25
0-value													
0-1	5-9												
0-2	10-24												
0-3	25-49												
0-4	50-74	4.00											
0-5	75-99	3.50											
0-6	100-124	2.75	1.50	4.25	4.75								
0-7	125-149	2.50	2.75	3.00	3.25	4.50	5.00						
0-8	150-199	2.00	2.25	2.50	2.75	3.75	4.25	4.50	5.00				
0-9	200-249	1.75	2.00	2.00	2.25	2.25	2.25	2.25	2.25	4.50	5.00		
0-10	250-299	1.75	1.75	1.75	2.00	2.00	2.75	3.00	3.50	2.00	2.00	4.75	
0-11	300-350	1.50	1.50	1.50	1.50	1.50	1.50	1.50	1.50	3.75	4.25	4.75	
		1.25	1.25	1.25	1.25	1.25	2.50	2.50	3.00	3.25	3.75	4.00	4.50
		1.00	1.25	1.50	1.75	2.00	2.25	2.25	1.25	1.25	1.25	1.25	1.25
		1.00	1.25	1.50	1.75	2.00	2.25	2.25	2.50	2.75	3.25	3.50	4.00
		1.00	1.00	1.00	1.00	1.00	1.00	1.00	1.00	1.00	1.00	1.00	1.00

Packaging code	L1	L2	L3	L4	L5	L6	L7	L8	L9	L10	L11	L12	L13
	UNIT WEIGHT OF ARTICLE TO BE PACKED												
	Pounds per square inch												
Fragility of article	0.05 thru 0.09	0.10 thru 0.14	0.15 thru 0.19	0.20 thru 0.24	0.25 thru 0.29	0.30 thru 0.34	0.35 thru 0.39	0.40 thru 0.44	0.45 thru 0.54	0.55 thru 0.64	0.65 thru 0.84	0.85 thru 1.04	1.05 thru 1.25
Q-value													
0-1	5-9												
0-2	10-24												
0-3	25-49												
0-4	50-74	5.00 3.50											
0-5	75-99	3.75 2.50	5.00 2.75										
0-6	100-124	3.00 2.00	4.00 2.25	5.00 2.50									
0-7	125-149	2.50 1.75	3.50 2.00	4.25 2.00	5.00 2.25								
0-8	150-199	2.25 1.50	3.00 1.75	3.75 1.75	4.50 2.00	5.00 2.00							
0-9	200-249	1.75 1.25	2.50 1.25	3.00 1.50	3.50 1.50	4.00 1.50	1.00 1.50						
0-10	250-299	1.50 1.00	2.00 1.00	2.50 1.25	3.00 1.25	3.50 1.25	4.00 1.50	4.50 1.50					
0-11	300-350	1.25 1.00	1.75 1.00	2.25 1.00	2.50 1.00	3.25 1.00	3.50 1.00	3.75 1.00	4.50 1.00	5.00 1.00			

Packaging code	L1	L2	L3	L4	L5	L6	L7	L8	L9	L10	L11	L12	L13
	UNIT WEIGHT OF ARTICLE TO BE PACKED												
	Pounds per square inch												
Fragility of article	0.05 thru 0.09	0.10 thru 0.14	0.15 thru 0.19	0.20 thru 0.24	0.25 thru 0.29	0.30 thru 0.34	0.35 thru 0.39	0.40 thru 0.44	0.45 thru 0.54	0.55 thru 0.64	0.65 thru 0.84	0.85 thru 1.04	1.05 thru 1.25
G-value													
0-1 5-9													
0-2 10-24													
0-3 25-49	3.50	5.00											
0-4 50-74	2.25	3.00	3.75	4.25	5.00								
0-5 75-99	1.75	2.25	2.75	3.25	3.50	4.00	4.50	5.00					
0-6 100-124		1.75	2.25	2.50	3.00	3.25	3.50	4.00	4.50	5.00			
0-7 125-149		1.50	2.00	2.25	2.50	2.75	3.00	3.25	3.75	4.25	5.00		
0-8 150-199	1.00	1.25	1.75	2.00	2.25	2.50	2.75	3.00	3.25	3.75	4.50	5.00	
0-9 200-249				1.50	1.75	2.00	2.25	2.50	2.75	3.00	3.75	4.25	4.75
0-10 250-299				1.50	1.50	1.75	2.00	2.25	2.25	2.50	3.00	3.50	4.00
0-11 300-350			1.00			1.50	1.75	1.75	2.00	2.25	2.75	3.25	3.50

NOT SUITABLE FOR USE AT LOW TEMPERATURES

Material No.

Packaging code	L1	L2	L3	L4	L5	L6	L7	L8	L9	L10	L11	L12	L13
	UNIT WEIGHT OF ARTICLE TO BE PACKED												
	Pounds per square inch												
	0.05 thru 0.09	0.10 thru 0.14	0.15 thru 0.19	0.20 thru 0.24	0.25 thru 0.29	0.30 thru 0.34	0.35 thru 0.39	0.40 thru 0.44	0.45 thru 0.54	0.55 thru 0.64	0.65 thru 0.84	0.85 thru 1.04	1.05 thru 1.25
<u>G-value</u>													
0-1	5-9												
0-2	10-24												
0-3	25-49	3.50	4.75										
0-4	50-74	2.00	2.75	3.50	4.00	4.50	5.00						
0-5	75-99	1.50	2.00	2.50	3.00	3.75	4.00	4.50	5.00				
0-6	100-124	1.25	1.75	2.00	2.25	3.00	3.25	3.50	4.00	4.50	5.00		
0-7	125-149		1.50	1.75	2.00	2.50	2.75	3.00	3.25	3.75	4.50	5.00	
0-8	150-199	1.00	1.25	1.50	1.75	2.00	2.25	2.50	3.00	3.25	4.00	4.50	5.00
0-9	200-249		1.00	1.25	1.50	1.75	2.00	2.25	2.50	2.75	3.00	3.50	4.00
0-10	250-299					1.50	1.75	1.75	2.00	2.25	2.50	3.00	3.50
0-11	300-350	.50					1.50	1.50	1.75	2.00	2.25	2.50	3.00

4 90096 7

NOT SUITABLE FOR USE AT LOW TEMPERATURES

Material No.

Packaging code	L1	L2	L3	L4	L5	L6	L7	L8	L9	L10	L11	L12	L13
	UNIT WEIGHT OF ARTICLE TO BE TESTED												
	Pounds per square inch												
Fragility of article	0.05 thru 0.09	0.10 thru 0.14	0.15 thru 0.19	0.20 thru 0.24	0.25 thru 0.29	0.30 thru 0.34	0.35 thru 0.39	0.40 thru 0.44	0.45 thru 0.54	0.55 thru 0.64	0.65 thru 0.84	0.85 thru 1.04	1.05 thru 1.25
G-value													
0-1	5-9												
0-2	10-24												
0-3	25-49	4.50											
0-4	50-74	2.25	3.00	3.50	3.75	4.50	5.00						
0-5	75-99	1.50	2.00	2.25	2.50	3.00	3.50	3.75	4.25	5.00			
0-6	100-124	1.25	1.50	1.75	2.00	2.50	2.75	3.00	3.50	4.00	4.75		
0-7	125-149	1.00	1.25	1.50	1.75				3.00	3.25	3.50	3.75	5.00
0-8	150-199		1.00	1.25	1.50	1.75		2.25	2.50	3.00	3.25	3.50	3.75
0-9	200-249					1.25			2.00	2.25	3.00	3.25	3.75
0-10	250-299								1.75	2.00	2.50	3.00	3.25
0-11	300-350									1.75	2.00	2.50	2.75

NOT SUITABLE FOR USE AT LOW TEMPERATURES

Packaging code	L1	L2	L3	L4	L5	L6	L7	L8	L9	L10	L11	L12	L13
	UNIT WEIGHT OF ARTICLE TO BE PACKED												
Pounds per square inch													
Fragility of article	0.05 thru 0.09	0.10 thru 0.14	0.15 thru 0.19	0.20 thru 0.24	0.25 thru 0.29	0.30 thru 0.34	0.35 thru 0.39	0.40 thru 0.44	0.45 thru 0.54	0.55 thru 0.64	0.65 thru 0.84	0.85 thru 1.04	1.05 thru 1.25
0-1	5-9												
0-2	10-24												
0-3	25-49												
0-4	50-74												
0-5	75-99	5.00 thru 3.75											
0-6	100-124	4.00 thru 3.25	4.50 thru 3.25	5.00 thru 3.25									
0-7	125-149	3.50 thru 2.75	3.75 thru 2.75	4.00 thru 2.75	4.50 thru 2.50	4.50 thru 2.50		4.75 thru 2.50	5.00 thru 2.50				
0-8	150-199	3.00 thru 2.25	3.25 thru 2.25	3.50 thru 2.25	3.75 thru 2.25	4.00 thru 2.25	4.00 thru 2.25		4.25 thru 2.25	4.50 thru 2.25	4.75 thru 2.25	5.00 thru 2.25	
0-9	200-249	2.25 thru 2.00	2.50 thru 2.00	2.75 thru 2.00	3.00 thru 2.00	3.00 thru 2.00	3.25 thru 2.00	3.25 thru 2.00	3.50 thru 2.00	3.75 thru 1.75	4.00 thru 1.75	4.00 thru 1.75	
0-10	250-299	2.00 thru 1.50	2.25 thru 1.50	2.50 thru 1.50	2.50 thru 1.50	2.50 thru 1.50	2.50 thru 1.50	2.75 thru 1.50	3.00 thru 1.50	3.00 thru 1.50	3.00 thru 1.50	3.25 thru 1.50	
0-11	300-350	1.75 thru 1.25	2.00 thru 1.25	2.00 thru 1.25	2.25 thru 1.25	2.25 thru 1.25	2.25 thru 1.25	2.50 thru 1.25	2.50 thru 1.25	2.75 thru 1.25	2.75 thru 1.25	3.00 thru 1.25	3.00 thru 1.25

Packaging code	L1	L2	L3	L4	L5	L6	L7	L8	L9	L10	L11	L12	L13
	UNIT WEIGHT OF ARTICLE TO BE PACKED												
	Pounds per square inch												
Fragility of article	0.05 thru 0.09	0.10 thru 0.14	0.15 thru 0.19	0.20 thru 0.24	0.25 thru 0.29	0.30 thru 0.34	0.35 thru 0.39	0.40 thru 0.44	0.45 thru 0.54	0.55 thru 0.64	0.65 thru 0.84	0.85 thru 1.04	1.05 thru 1.25
0-1													
0-2													
0-3													
0-4	4.50												
0-5	3.75	5.00											
0-6	3.00	3.50											
0-7	3.25	4.50											
0-8	2.75	3.25											
0-9	4.00	5.00											
0-10	3.00	3.50											
0-11	4.50	4.50											
	2.75	2.00	5.00										
	2.50	2.75	4.25	4.75									
	2.25	3.25	3.00	2.75									
	2.25	2.50	3.75	4.50									
	2.25	3.00	2.50	2.50									
	2.25	3.00	3.50	4.25	4.75								
	2.00	2.50	2.50	2.50	2.50								

608

NOT SUITABLE FOR USE AT LOW TEMPERATURES

Packaging code	L1	L2	L3	L4	L5	L6	L7	L8	L9	L10	L11	L12	L13
	UNIT WEIGHT OF ARTICLE TO BE PACKED												
	Pounds per square inch												
Fragility of article	0.05 thru 0.09	0.10 thru 0.14	0.15 thru 0.19	0.20 thru 0.24	0.25 thru 0.29	0.30 thru 0.34	0.35 thru 0.39	0.40 thru 0.44	0.45 thru 0.54	0.55 thru 0.64	0.65 thru 0.84	0.85 thru 1.04	1.05 thru 1.25
G-value													
6-1	5-9												
6-2	10-24												
6-3	25-49												
6-4	50-74	4.25											
6-5	75-99	3.75	4.50	5.00									
6-6	100-124	3.50	3.75	3.25	3.75	4.50	5.00						
6-7	125-149	3.00	3.25	3.50	3.25	3.50	3.25	4.00	4.50	5.00			
6-8	150-199	2.50	3.00	3.50	4.00	4.50	5.00	5.00	5.00	5.00			
6-9	200-249	2.50	2.50	2.75	2.50	2.50	2.25	4.75	4.50	4.50	4.75	4.75	
6-10	250-299	2.00	2.75	3.00	3.50	3.75	4.00	4.00	4.00	4.00	4.75	5.00	
6-11	300-350	1.75	2.00	2.25	2.75	3.00	3.75	4.00	4.25	4.75	5.00	5.00	

60%

NOT SUITABLE FOR USE AT LOW TEMPERATURES

Packaging code	L1	L2	L3	L4	L5	L6	L7	L8	L9	L10	L11	L12	L13
	UNIT WEIGHT OF ARTICLES TO BE PACKED												
Fragility of article	Pounds per square inch												
	0.05 thru 0.09	0.10 thru 0.14	0.15 thru 0.19	0.20 thru 0.24	0.25 thru 0.29	0.30 thru 0.34	0.35 thru 0.39	0.40 thru 0.44	0.45 thru 0.54	0.55 thru 0.64	0.65 thru 0.84	0.85 thru 1.04	1.05 thru 1.25
0-1	5-9												
0-2	10-24												
0-3	25-49	5.00 4.50											
0-4	50-74	3.75 3.50	5.00 4.50										
0-5	75-99	2.50 2.50	3.50 3.25	4.25 3.50	5.00 4.00								
0-6	100-124	2.00 2.00	2.75 2.50	3.50 3.00	4.00 3.25	5.00 4.00							
0-7	125-149	1.75 1.75	2.50 2.25	2.75 2.50	3.25 2.75	4.25 3.25	5.00 3.25						
0-8	150-199	1.50 1.50	2.00 2.50	2.25 2.00	2.75 2.50	3.25 2.75	4.00 3.00	5.00 3.00					
0-9	200-249	1.25 1.25	1.50 1.50	2.00 1.75	2.25 2.00	2.75 2.00	3.25 2.00	4.00 2.25	5.00 2.25				
0-10	250-299	1.00 1.00	1.25 1.25	1.75 1.50	2.00 1.75	2.50 2.00	3.00 2.50	4.00 2.00	5.00 2.00				
0-11	300-350	1.00 1.00	1.25 1.25	1.50 1.25	1.75 1.50	2.00 1.75	2.50 1.75	3.25 1.75	4.00 2.00	5.00 2.00			

408

NOT SUITABLE FOR USE AT LOW TEMPERATURES

Packaging code	L1	L2	L3	L4	L5	L6	L7	L8	L9	L10	L11	L12	L13
	UNIT WEIGHT OF ARTICLE TO BE PACKED												
Pounds per square inch													
Fragility of article	0.05 thru 0.09	0.10 thru 0.14	0.15 thru 0.19	0.20 thru 0.24	0.25 thru 0.29	0.30 thru 0.34	0.35 thru 0.39	0.40 thru 0.44	0.45 thru 0.54	0.55 thru 0.64	0.65 thru 0.84	0.85 thru 1.04	1.05 thru 1.25
0-1													
0-2													
0-3													
0-4													
0-5	4.25 thru 3.75												
0-6	3.00 thru 2.75	3.50 thru 3.00		3.75 thru 3.25	4.00 thru 3.25	4.25 thru 3.50				4.50 thru 3.50	4.75 thru 3.50	5.00 thru 3.75	
0-7	2.50 thru 2.50	2.75 thru 2.50		3.00 thru 2.50	3.25 thru 2.75	3.50 thru 2.75			3.50 thru 2.75		3.75 thru 3.00	4.00 thru 3.00	
0-8	2.25 thru 2.00	2.25 thru 2.00		2.50 thru 2.25	2.75 thru 2.25	3.00 thru 2.50			3.00 thru 2.25		3.25 thru 2.50	3.50 thru 2.50	
0-9	1.25 thru 1.25	1.75 thru 1.50		2.00 thru 1.75	2.25 thru 1.75	2.50 thru 1.75			2.25 thru 1.75		2.50 thru 2.00	2.75 thru 2.00	
0-10	1.00 thru 1.00	1.25 thru 1.25	1.50 thru 1.25	1.75 thru 1.50	2.00 thru 1.75	2.25 thru 1.75	1.75 thru 1.50		1.75 thru 1.50		2.00 thru 1.50	2.25 thru 1.75	
0-11	1.00 thru 1.00	1.25 thru 1.25	1.50 thru 1.25	1.75 thru 1.25	2.00 thru 1.25	2.25 thru 1.25	1.50 thru 1.25		1.50 thru 1.25		1.75 thru 1.25	2.00 thru 1.25	

207

Packaging code	L1	L2	L3	L4	L5	L6	L7	L8	L9	L10	L11	L12	L13
	UNIT WEIGHT OF ARTICLE TO BE PACKED												
	Pounds per square inch												
Fragility of article	0.05 thru 0.09	0.10 thru 0.14	0.15 thru 0.19	0.20 thru 0.24	0.25 thru 0.29	0.30 thru 0.34	0.35 thru 0.39	0.40 thru 0.44	0.45 thru 0.54	0.55 thru 0.64	0.65 thru 0.84	0.85 thru 1.04	1.05 thru 1.25
<u>0-values</u>													
0-1 5-9													
0-2 10-24													
0-3 25-49													
0-4 50-74													
0-5 75-99	4.50 4.25	5.00 4.50											
0-6 100-124	3.25 3.00	3.50 3.25	3.75 3.25		4.00 3.50		4.25 3.50		4.50 3.50		4.75 3.75		
0-7 125-149	2.50 2.50	2.75 2.50	3.00 2.75	3.25 2.75						3.50 2.75	3.75 3.00	4.00 3.00	
0-8 150-199	2.00 2.00	2.25 2.00	2.50 2.25							2.75 2.25	3.00 2.50	3.00 2.50	
0-9 200-249	1.50 1.50			1.75 1.50						2.00 1.75	2.25 1.75	2.25 1.75	2.25 1.75
0-10 250-299				1.25 1.25					1.50 1.25				1.50 1.50
0-11 300-350									1.25 1.00				1.50 1.25

Packaging code	L1	L2	L3	L4	L5	L6	L7	L8	L9	L10	L11	L12	L13
	UNIT WEIGHT OF ARTICLE TO BE PACKED												
Fragility of article	Pounds per square inch												
	0.05 thru 0.09	0.10 thru 0.14	0.15 thru 0.19	0.20 thru 0.24	0.25 thru 0.29	0.30 thru 0.34	0.35 thru 0.39	0.40 thru 0.44	0.45 thru 0.54	0.55 thru 0.64	0.65 thru 0.84	0.85 thru 1.04	1.05 thru 1.25
0-1													
0-2													
0-3													
0-4	4.50												
0-5	3.75												
0-6	3.00	4.00	4.50	5.00									
	2.50	3.00	3.25	3.50									
0-7	2.50	3.00	3.50	4.00	4.50	5.00							
	2.00	2.25	2.50	2.50	2.50	2.50							
0-8	2.00	2.50	3.00	3.25	3.75	4.00	5.00						
	1.75	2.00	2.00	2.00	2.25	2.25	2.25						
0-9	1.75	2.00	2.50	2.75	3.00	3.25	3.75	4.00	4.25	4.75			
	1.50	1.50	1.75	1.75	1.75	1.75	2.00	2.00	2.00	2.00			
0-10	1.25	1.75	2.00	2.25	2.50	2.75	3.00	3.00	3.25	3.50	4.00	4.75	5.00
	1.00	1.25	1.50	1.50	1.50	1.50	1.50	1.50	1.50	1.50	1.50	1.50	1.50
0-11	1.00		1.50	1.75	2.00	2.25	2.25	2.50	2.75	3.00	3.50	3.75	4.25
	1.00	1.25	1.00	1.00	1.00	1.25	1.25	1.25	1.25	1.25	1.25	1.25	1.25
		1.00	1.00	1.75	2.00	2.00	2.00	2.25	2.25	2.50	3.00	3.25	3.50
		1.00	1.00	1.00	1.00	1.00	1.00	1.00	1.00	1.00	1.00	1.00	1.00

Packaging code	L1	L2	L3	L4	L5	L6	L7	L8	L9	L10	L11	L12	L13
	UNIT WEIGHT OF ARTICLE TO BE PACKED												
	Pounds per square inch												
Fragility of articles	0.05 thru 0.09	0.10 thru 0.14	0.15 thru 0.19	0.20 thru 0.24	0.25 thru 0.29	0.30 thru 0.34	0.35 thru 0.39	0.40 thru 0.44	0.45 thru 0.54	0.55 thru 0.64	0.65 thru 0.84	0.85 thru 1.04	1.05 thru 1.25
G-value													
0-1 5-9													
0-2 10-24													
0-3 25-49													
0-4 50-74	4.50												
0-5 75-99	3.50												
0-6 100-124	4.25												
0-7 125-149	3.25												
0-8 150-199	3.25	4.00	4.75										
0-9 200-249	3.25	3.00	3.25	4.25	4.50	5.00							
0-10 250-299	2.75	3.25	3.75	2.75	2.75	2.75	4.50	4.75					
0-11 300-350	2.25	2.25	2.75	3.50	3.75	4.25	2.25	2.25	4.00	4.50	5.00	4.50	4.75
	2.25	2.00	2.25	2.25	2.25	2.25	2.25	2.25	1.75	1.75	1.50	1.25	1.25
	1.50	1.75	1.50	1.50	1.50	1.75	1.75	1.75	3.00	3.50	4.00	3.75	4.25
	1.25	2.00	2.00	2.25	2.50	2.25	2.75	3.00	1.25	1.25	1.25	1.00	1.00
	1.00	1.50	1.75	2.00	2.00	2.25	2.50	2.50	2.75	3.00	3.50	3.75	4.25
		1.25	1.25	1.50	1.50	1.75	1.75	1.75	1.00	1.00	1.00	1.00	1.00
		2.00	2.25	2.25	2.25	2.25	2.25	2.25	2.75	3.00	3.50	3.75	4.25
		2.25	2.25	2.25	2.25	2.25	2.25	2.25	2.25	2.25	2.25	2.25	2.25
		2.25	2.25	2.25	2.25	2.25	2.25	2.25	2.25	2.25	2.25	2.25	2.25

Packaging code	L1	L2	L3	L4	L5	L6	L7	L8	L9	L10	L11	L12	L13
	UNIT WEIGHT OF ARTICLE TO BE PACKED												
Pounds per square inch													
Fragility of article	0.05 thru 0.09	0.10 thru 0.14	0.15 thru 0.19	0.20 thru 0.24	0.25 thru 0.29	0.30 thru 0.34	0.35 thru 0.39	0.40 thru 0.44	0.45 thru 0.54	0.55 thru 0.64	0.65 thru 0.84	0.85 thru 1.04	1.05 thru 1.25
0-1													
0-2													
0-3													
0-4													
0-5	4.00												
	3.25												
0-6	3.50	4.50											
	2.75	3.25											
0-7	3.00	4.00	4.75										
	2.50	2.75	2.75										
0-8	2.50	3.50	4.25	5.00									
	2.00	2.50	2.50	2.75									
0-9	2.25	3.00	3.50	4.00	4.75								
	1.75	2.25	2.25	2.25	2.25								
0-10	2.00	2.50	3.00	3.50	4.00	4.50	5.00						
	1.75	1.75	2.00	2.00	2.00	2.00	2.00						
0-11	1.75	2.25	2.75	3.25	3.50	4.00	4.25	4.75					
	1.50	1.50	1.75	1.75	1.75	1.75	1.75	2.00					

60%

NOT SUITABLE FOR USE AT LOW TEMPERATURES

Packaging code	L1	L2	L3	L4	L5	L6	L7	L8	L9	L10	L11	L12	L13
	UNIT WEIGHT OF ARTICLE TO BE PACKED												
	Pounds per square inch												
Fragility of articles	0.05 thru 0.09	0.10 thru 0.14	0.15 thru 0.19	0.20 thru 0.24	0.25 thru 0.29	0.30 thru 0.34	0.35 thru 0.39	0.40 thru 0.44	0.45 thru 0.54	0.55 thru 0.64	0.65 thru 0.84	0.85 thru 1.04	1.05 thru 1.25
<u>G-value</u>													
0-1													
0-2													
0-3													
0-4	5.00												
0-5	3.75												
0-6	3.50	4.25	5.00										
0-7	2.50	2.75	2.75										
0-8	2.75	3.50	4.00	4.50	4.75	5.00							
0-9	2.00	2.25	2.25	2.25	2.50	2.50							
0-10	2.25	2.75	3.25	3.50	4.00	4.25	4.50	4.75					
0-11	1.75	1.75	1.75	1.75	2.00	2.00	2.00	2.00					
0-12	2.00	2.25	2.75	3.00	3.50	3.75	4.00	4.25	4.50	5.00			
0-13	1.50	1.50	1.50	1.50	1.75	1.75	2.00	2.00	2.00	2.00			
0-14	1.50	2.00	2.25	2.50	2.75	2.75	3.00	3.25	3.50	4.00	4.25	4.75	5.00
0-15	1.25	1.25	1.25	1.25	1.25	1.25	1.25	1.50	1.50	1.50	1.50	1.50	1.75
0-16	1.25	1.50	1.75	2.00	2.25	2.25	2.50	2.75	3.00	3.25	3.50	4.00	4.50
0-17	1.00	1.00	1.00	1.00	1.25	1.25	1.25	1.25	1.25	1.25	1.25	1.25	1.50
0-18	1.00	1.25	1.50	1.75	2.00	2.00	2.25	2.25	2.50	2.75	3.25	3.50	3.75
0-19	1.00	1.00	1.00	1.00	1.00	1.00	1.00	1.00	1.00	1.00	1.25	1.25	1.25

507

Identification Code for Materials  
and Manufacturer

1	1/4" Foam (Soft)	Goodyear Tire & Rubber Co., Inc. 1144 E. Superior St. Akron 16, Ohio	Blair Cotton Wooling	Union Wooling Company P. O. Box 809 Providence, Rhode Island	28	Parlatex (Medium)	Blackman and Company P.O. Box 150 Michigan City, Indiana
2	1/4" Foam (Medium)				27	Parlatex (Firm)	
3	1/4" Foam (Firm)				26	Proform Co-1	American Resilator Corporation 1000 N. Halsted St. Chicago 2, Illinois
4	Black Pencil SB	Proform and Rubber Company Lockwood Cincinnati 11, Ohio			25	Proform Co-2	
5	Blair Lenses SB				24	Parlatex	Queen City Parlatex Corporation Berlin, Vermont
6	Mount to Collations	Mount to Corporation Colligam Products Division 111 W. Washington St. Chicago 2, Illinois			23	Blair Lens	Blair Lens Div. 400 Fourth Ave. New York, New York
7	Blair-Lex (Medium)	Arner and Company 1100 W. Clark Street Chicago 9, Illinois			22	Parlatex Corp. Parlatex Type 11 Clark 9	Wood Corporation Co. First National Bank Bldg St. Paul, Minnesota
8	Blair-Lex (Firm)				21	Expalon Foam (Soft)	Island Station Rubber Co. Expalon Foam Division Baltimore, Indiana
9	Formex #2 (Soft)	The Firestone Industrial Prod. Co. 1100 Firestone Parkway Akron 16, Ohio			20	Expalon Foam (Medium)	
10	Formex #2 (Medium)				19	Expalon #00 (Single embossed)	
11	Formex #4 (Firm)				18	Expalon #00 (Firm)	
12	Forest Plaster	Forest Paper Corporation 25 Washington Ave. Boston 10, Massachusetts			17	Expalon #01 (Double embossed)	
13	Jiffy Pads	Jiffy Manufacturing Company 240 Florence Ave. Milwaukee, New Jersey			16	Expalon #02 (Single embossed)	
14	Blair Cotton Wooling				15	Expalon #01 (Firm)	
15	Expalon #01 (Firm)				14	Expalon #02 (Firm)	
16	Expalon #02 (Single embossed)				13	Expalon #01 (Single embossed)	
17	Expalon #01 (Firm)				12	Expalon #01 (Double embossed)	
18	Expalon #00 (Firm)				11	Expalon #00 (Firm)	
19	Expalon #00 (Single embossed)				10	Expalon #02 (Compressed)	
20	Expalon #02 (Compressed)				9	Proform #00	
21	Expalon Foam (Soft)				8	Proform #01	
22	Expalon Foam (Medium)				7	Proform #02	
23	Expalon Foam (Firm)				6	Proform #03	
24	Proform #00				5	Proform #04	
25	Proform #01 (Soft)				4	Proform #05	
					3	Proform #06	
					2	Proform #07	
					1	Proform #08	