

UNCLASSIFIED

AD NUMBER
AD024766
NEW LIMITATION CHANGE
TO Approved for public release, distribution unlimited
FROM Distribution authorized to U.S. Gov't. agencies and their contractors; Administrative/Operational Use; 10 Nov 1953. Other requests shall be referred to Director, Naval Research Laboratory, Washington, DC 20375.
AUTHORITY
NRL ltr, 15 Oct 2003

THIS PAGE IS UNCLASSIFIED

Armed Services Technical Information Agency

AD

PLEASE RETURN THIS COPY TO:

**ARMED SERVICES TECHNICAL INFORMATION AGENCY
DOCUMENT SERVICE CENTER
Knott Building, Dayton 2, Ohio**

Because of our limited supply you are requested to return this copy as soon as it has served your purpose so that it may be made available to others for reference use. Your cooperation will be appreciated.

24766

NOTICE: WHEN GOVERNMENT OR OTHER DRAWINGS, SPECIFICATIONS OR OTHER DATA ARE USED FOR ANY PURPOSE OTHER THAN IN CONNECTION WITH A DEFINITELY RELATED GOVERNMENT PROCUREMENT OPERATION, THE U. S. GOVERNMENT THEREBY INCURS NO RESPONSIBILITY, NOR ANY OBLIGATION WHATSOEVER; AND THE FACT THAT THE GOVERNMENT MAY HAVE FORMULATED, FURNISHED, OR IN ANY WAY SUPPLIED THE SAID DRAWINGS, SPECIFICATIONS, OR OTHER DATA IS NOT TO BE REGARDED BY IMPLICATION OR OTHERWISE AS IN ANY MANNER LICENSING THE HOLDER OR ANY OTHER PERSON OR CORPORATION, OR CONVEYING ANY RIGHTS OR PERMISSION TO MANUFACTURE, USE OR SELL ANY PATENTED INVENTION THAT MAY IN ANY WAY BE RELATED THERETO.

Reproduced by

DOCUMENT SERVICE CENTER

KNOTT BUILDING, DAYTON, 2, OHIO

REPRODUCED FROM
BEST AVAILABLE COPY

REPRODUCED FROM
BEST AVAILABLE COPY

UNCLASSIFIED

AD No. 24766
ASTIA FILE COPY

NRL Report 4218

DIELECTRIC QUARTER-WAVE AND HALF-WAVE PLATES IN CIRCULAR WAVEGUIDE

R. M. Brown and A. J. Simmons

Antenna Research Branch
Radio Division I

November 10, 1953



NAVAL RESEARCH LABORATORY
Washington, D.C.

CONTENTS

Abstract	ii
Problem Status	ii
Authorization	ii
INTRODUCTION	1
SLAB THICKNESS	2
IMPEDANCE MATCHING	4
QUARTER-WAVE AND HALF-WAVE PLATES	5
ROTARY PHASE SHIFTER	8
PHASE-SHIFTLESS ATTENUATOR	12
SPECIAL INSTRUMENTATION	12
ACKNOWLEDGMENTS	15
APPENDIX A - Errors in the Rotary Phase Shifter	16
APPENDIX B - Calibration of the Rotary Phase Shifter	19
APPENDIX C - Errors caused by Slightly Elliptical Waveguide	20

ABSTRACT

An experimental program at NRL has led to the design of quarter-wave and half-wave plates in X-band circular waveguide. The plates are polystyrene slabs, tapered to reduce reflections, and are mounted in a diametral plane of the waveguide. Quarter-wave plates having differential phase shifts of between 88° and 92° from 8750 to 9700 Mc were built. A half-wave plate having a phase shift of between 176° and 186° from 8200 to 10,000 Mc was built. The VSWR'S of the plates were less than 1.2 in these frequency ranges. Several rotary phase shifters using these plates were found to deviate from linearity by less than $\pm 0.5^\circ$ at 9375 Mc. The effect of imperfect plates on the performance of the rotary phase shifter, the calibration of the rotary phase shifter, and the errors caused by slightly noncircular waveguide are discussed in the appendixes.

PROBLEM STATUS

This is an interim report; work is continuing on this problem.

AUTHORIZATION

NRL Problem R09-52
RDB Project NR 509-530

Manuscript submitted August 12, 1953

DIELECTRIC QUARTER-WAVE AND HALF-WAVE PLATES IN CIRCULAR WAVEGUIDE

INTRODUCTION

A recent study at NRL has been concerned with the design of broadband dielectric quarter-wave and half-wave plates in X-band circular waveguide.¹ The frequency range covered is that recommended for the 15/16-inch-id waveguide: 8300 to 9700 Mc. These plates are tapered dielectric slabs mounted in a diametral plane of the waveguide so that the dominant modes² polarized respectively parallel to and transverse to that plane propagate with different phase velocities, thus causing two in-phase waves to acquire a difference in phase on passing through the section. This difference is called the differential phase shift of the section and is denoted by $\Delta\phi$. For a quarter-wave plate $\Delta\phi$ is 90° ; for a half-wave plate, 180° .

The most important properties of quarter- and half-wave plates can be shown by considering, as in Figure 1, the result of mounting a plate of differential phase shift δ at an angle θ to an incident linearly polarized wave.³ Since the waveguide is circular, the incident wave can be resolved into two linear waves polarized respectively parallel to and normal to the slab. On input, these components are in phase and of relative amplitude $\cos \theta$ and $\sin \theta$. If the plate is assumed to be matched and lossless, the components on output are still of relative amplitude $\cos \theta$ and $\sin \theta$ but the parallel component lags in phase by δ .

For a quarter-wave plate at $\theta = 45^\circ$, the output consists of two orthogonal waves of equal amplitude and 90° out of phase; so, by definition, this output is circularly polarized. This conversion of linear to circular polarization (and vice versa) is the principal function of the quarter-wave plate. A linearly polarized wave incident on a half-wave plate at any angle θ is again linearly polarized on output but the plane of polarization is rotated through an angle of 2θ since the parallel component lags by 180° . It can also be shown that a circularly polarized wave incident on a half-wave plate is changed in sense (right-hand circular to left-hand circular and vice versa) with the phase of the output depending on the angular position of the half-wave plate. This latter property is utilized in the rotary phase shifter which is described in a later section.

The dielectric slab was chosen as the loading element, rather than metal fins or screws, because Eaton and Steinberger⁴ had previously shown that very broadband quarter-wave plates could be made by inserting a dielectric slab into a rectangular waveguide. They were able to determine, for a given dielectric, the slab thickness for which the differential phase shift per unit length was nearly constant as a function of frequency.

¹ Fox, A. G., US Patent 2,597,750

² The modes corresponding to the TE_{11} modes in unloaded circular waveguide

³ TE_{11} mode

⁴ Eaton, J. E., and Steinberger, J., "Broad-Band Antenna for Circular Polarization," MIT Radiation Laboratory Report 769, Jan. 28, 1946

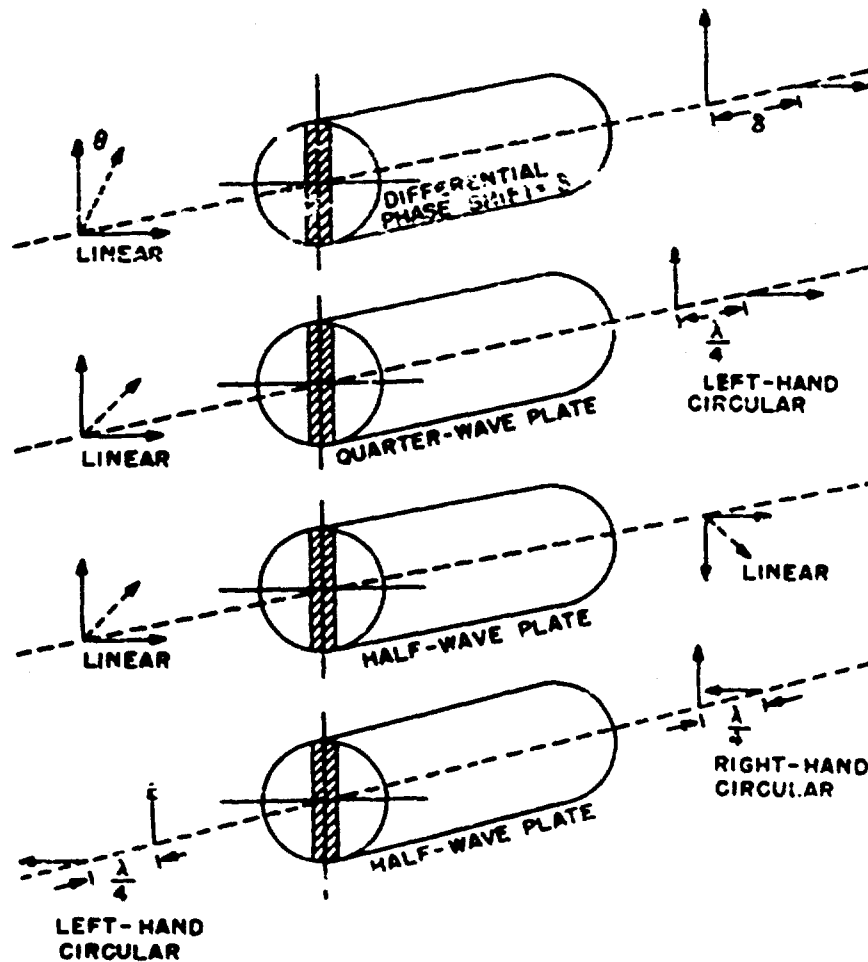

Figure 1 - Properties of differential phase-shift sections (vectors represent the component waves parallel and normal to the slab)

Their procedure depended upon a knowledge of the propagation constants for that geometry. A similar analysis for slab-loaded circular waveguide could not be made at this time since the mode problem has not been solved. As a result, the best slab thickness had to be found experimentally.

The program followed in designing the plates involved finding the optimum slab thickness, matching the slabs by the proper tapers, and finally combining the differential phase shifts produced by the tapers with that of the slab to obtain the required 90° or 180° . Since one of the primary applications of quarter- and half-wave plates is their use in the rotary phase shifter, several were built and tested. In Appendix A there is an analysis of the errors resulting from imperfect plates in a rotary phase shifter; in Appendix B the calibration of rotary phase shifters is explained; and in Appendix C there is a discussion of the experimental errors arising from slightly noncircular waveguide.

SLAB THICKNESS

Since the primary aim of this program was to design quarter-wave and half-wave plates having broadband characteristics, phase measurements were made on polystyrene slabs of six thicknesses ($1/16$, $1/8$, $3/16$, $1/4$, $5/16$, $3/8$ inch) to find the thickness for which the differential phase shift per unit length, $\Delta\phi$, was most nearly constant over the band. For each

thickness, $\Delta\phi$ was found by measuring in a slotted circular waveguide the guide wavelengths λ_p and λ_T of the parallel and transverse modes and then substituting these values in the relation

$$\Delta\phi = 360 \left(\frac{1}{\lambda_p} - \frac{1}{\lambda_T} \right) \text{ degrees/unit length.}$$

In Figures 2 and 3 are shown λ_p and λ_T and the corresponding values of $\Delta\phi$ for these six thicknesses. For all but the 1/16-inch sample, $\Delta\phi$ varied from constancy by less than $\pm 4\%$ but varied by only $\pm 2\%$ for the two thickest slabs. Since the probable error in $\Delta\phi$ ranged from 2 to 5%, depending upon the sample and the frequency, a choice was made on the basis of constancy of differential phase shift. However, it seemed desirable that the quarter- and half-wave plates be as compact as possible, so the three samples (3/16, 1/4, 3/8 inch) having the largest differential phase shifts were considered preferable to the others. Of these three, the thinnest (3/16 inch) was selected as best for the plates since, in general, thinner slabs are more easily matched to the guide.

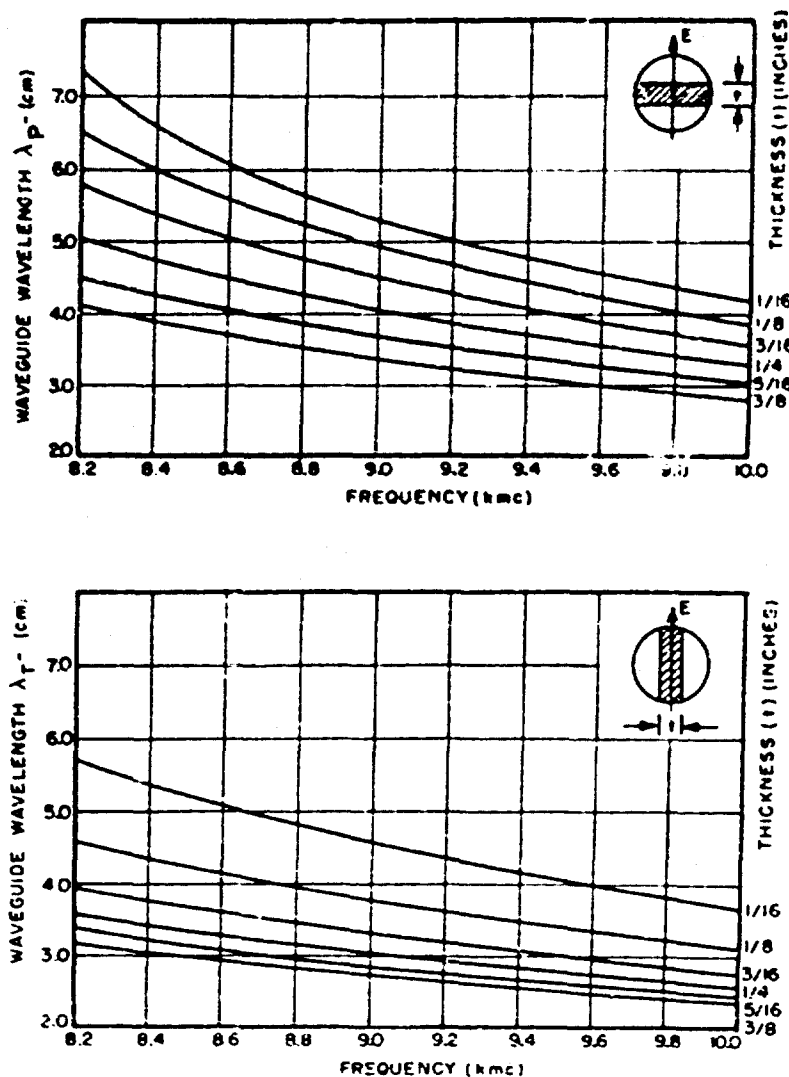

Figure 2 - Waveguide wavelength in dielectric loaded circular waveguide line

- a. Dielectric slab transverse to the electric field
- b. Dielectric slab parallel to the electric field

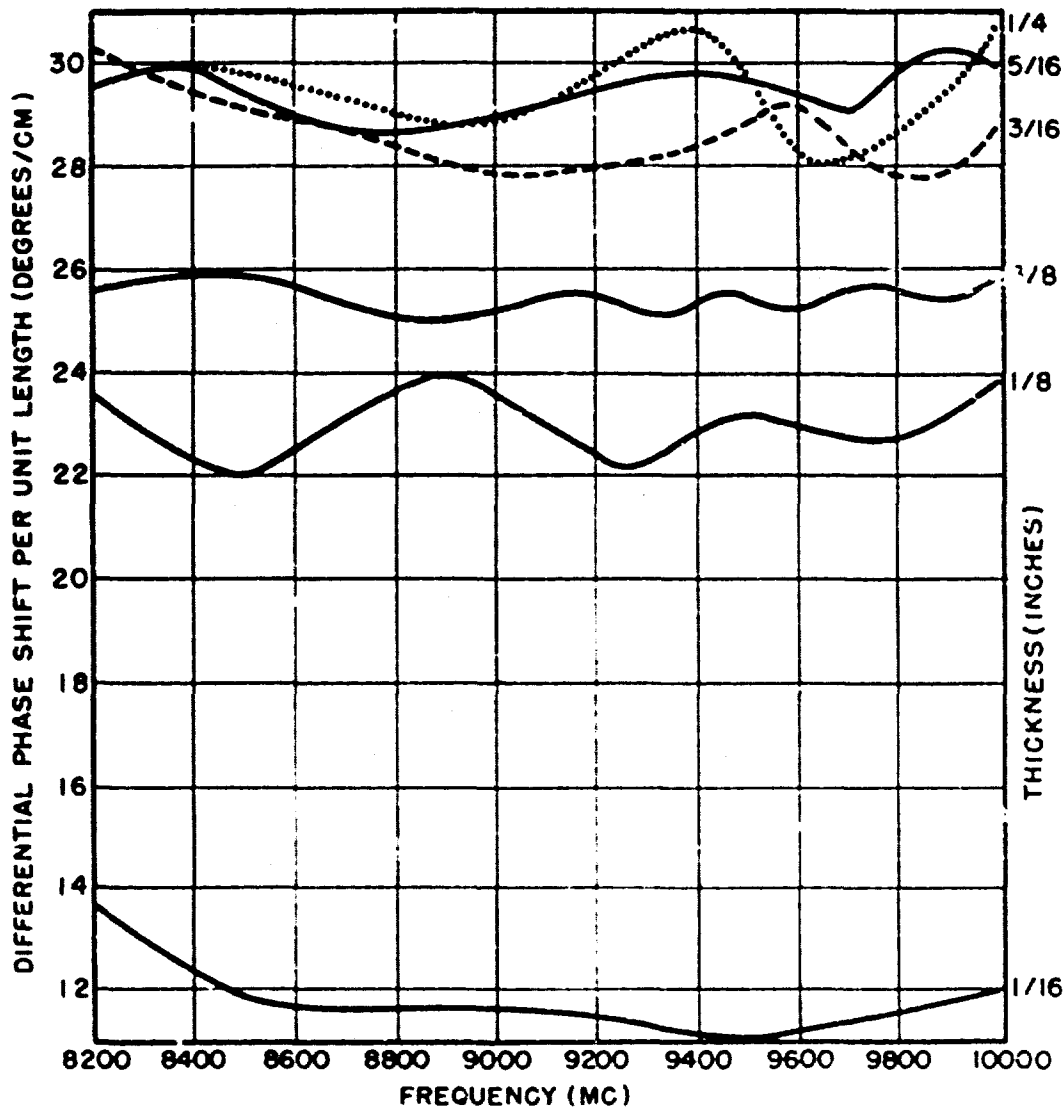

Figure 3 - Differential phase shift vs. frequency for six polystyrene slabs in circular waveguide

IMPEDANCE MATCHING

The usual methods of matching dielectric slabs are to cause cancelling reflections either by abrupt "steps" or by tapering. Since the plates must be matched in both planes, the latter course seemed the more reasonable. Accordingly, a series of tapered 3/16-inch polystyrene slabs was tested to find tapers of reasonable size which are well matched over the frequency band and also to find the best taper lengths for spot frequencies. The slabs were tapered in both planes to form a pyramidal end (Figure 4).

The reflection from a single such taper was obtained by isolating one end of the test slab by means of a nonreflecting termination, with the tapered end protruding into a section of unloaded guide. In Figure 5 the results of some of the VSWR measurements are shown. The tapers offering the most promise for use over the entire range were numbers 7, 8, 9, 10, all of which had VSWR'S less than 1.12 for the parallel mode and less than 1.07 for the transverse mode. Tapers 4 and 12 were the best from 9000 to 10,000 Mc since their VSWR'S in the two principal planes were less than 1.05 over this range.

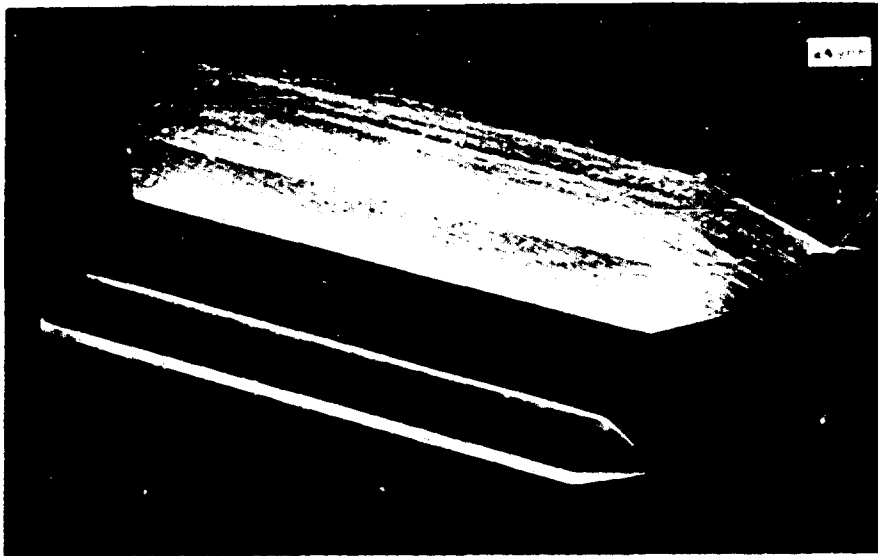

Figure 4 - Tapered polystyrene slabs

QUARTER-WAVE AND HALF-WAVE PLATES

Quarter-wave and half-wave plates were designed by measuring the differential phase shift of a pair of tapers mounted back-to-back and then, using $28.5^\circ/\text{cm}$ as the differential phase shift of a $3/16$ -inch slab, calculating the length of the center section having a phase shift equal to the difference between 90° (or 180°) and the differential phase shift of the tapers. Phase measurements on the plates then showed whether or not the center section had to be changed to minimize the average error over the band. In no case was it necessary to alter the length by more than 0.05 inch (approximately 3.5°).

The differential phase shifts of taper pairs and quarter- and half-wave plates were measured using a magic tee phase detector and calibrated phase shifter, as shown in Figure 6. Another method of checking the performance of quarter- and half-wave plates is to insert a plate at 45° to an incident linearly polarized wave and then to measure, with a rotatable probe, the ratio of maximum to minimum field strength on output. This ratio (called the voltage ellipticity ratio) is unity for a perfect quarter-wave plate, and infinite for a perfect half-wave plate since the outputs are respectively circularly and linearly polarized. Deviations from these values give a measure of the differential phase shifts of plates that are reasonably well matched. This procedure is not as accurate as the direct measurement of differential phase shift since the ellipticities of all the circular waveguide sections between the probe and the generator may add to that of the plate, while the direct method depends only on the accuracy of the rotatable section of guide. For this reason, no ellipticity measurements are included in this report.

The results of phase measurements on tapers 4, 9, 10, and 12 are given in Figure 7. Since these differential phase shifts ranged from 50° to 90° , it is seen that the frequency sensitivity of quarter-wave plates using these tapers will depend to a greater extent on the tapers than on the center section. Fortunately, the phase shifts of the tapers that were tested varied by less than $\pm 4\%$ over the band which is no worse than the variation for the $3/16$ -inch slab itself.

Taper 12, which was of length 1.850 inch, proved to be the longest taper (on a $3/16$ -inch slab) that could be used in a quarter-wave plate since the differential phase shift of a pair was between 87° and 91° over the band. Even though this taper pair was fairly well matched

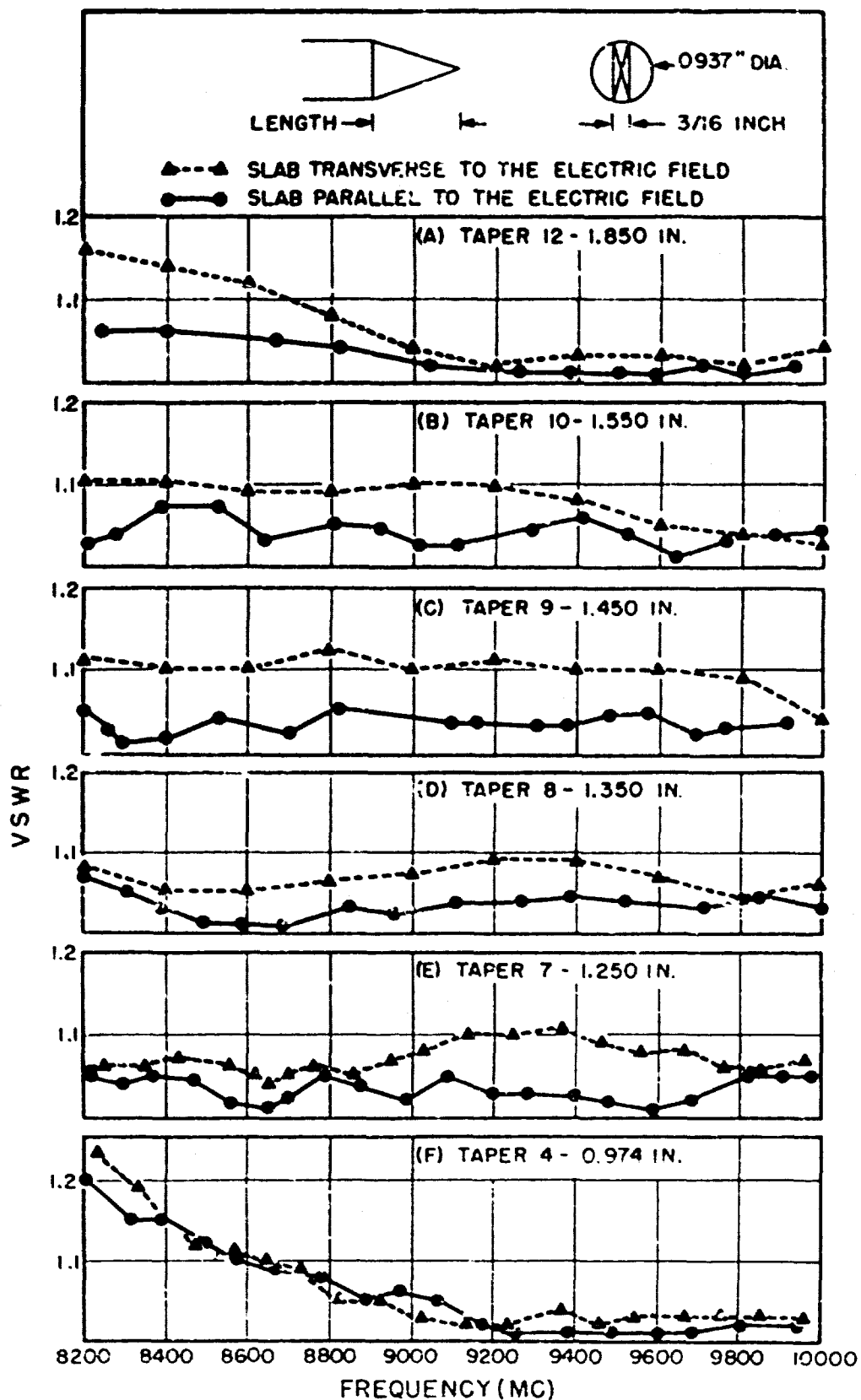

Figure 5 - Voltage standing wave ratios of tapered polystyrene slabs

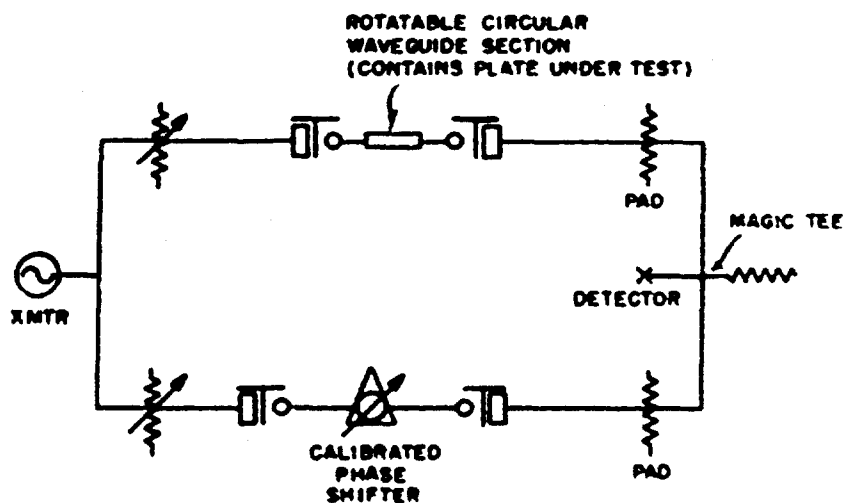

Figure 6 - Setup for measurement of differential phase shift

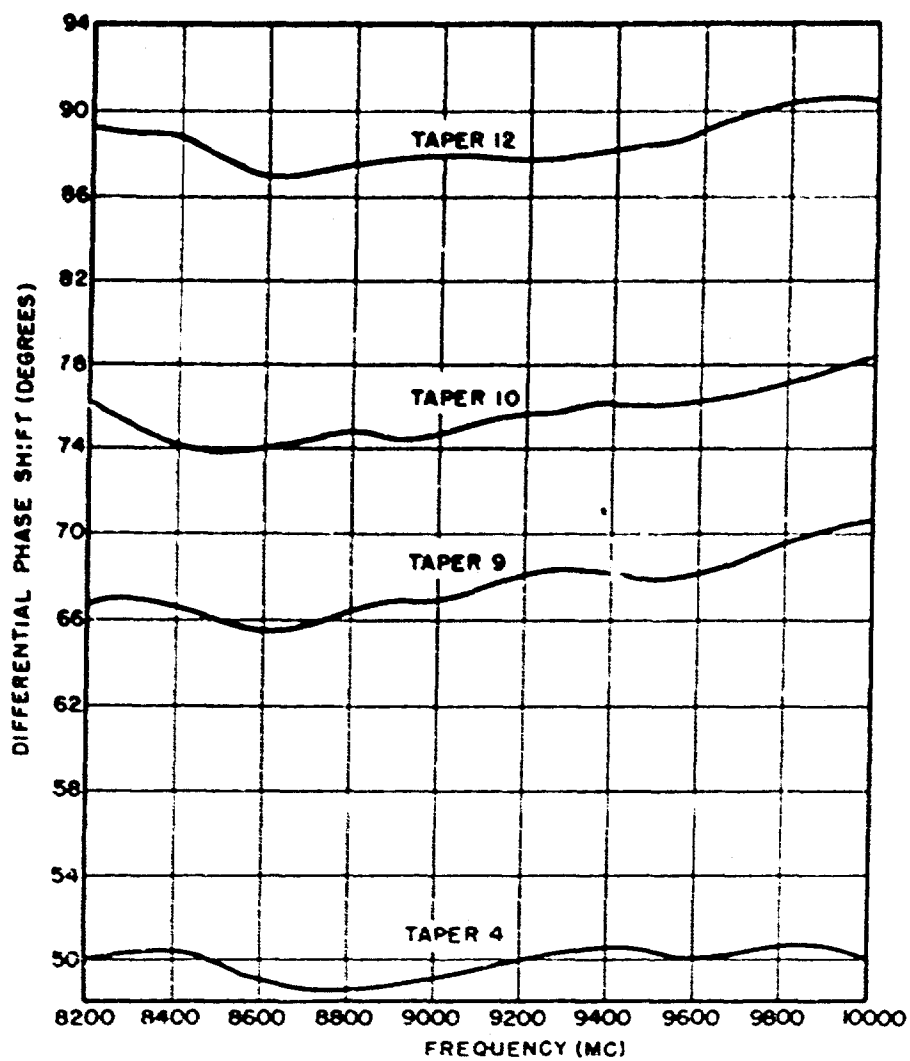

Figure 7 - Differential phase shift vs. frequency for polystyrene tapers mounted back-to-back

(VSWR less than 1.2 from 8550 to 10,000 Mc), it was not used as a quarter-wave plate since the lack of a center section caused difficulty in machining and in mounting in the waveguide.

Center sections of length 0.600, 0.320 and 0.205 inch were added to tapers 4, 9, and 10 respectively to provide the additional phase shift needed for quarter-wave plates. The electrical characteristics of the three were quite similar. All had differential phase shifts of between 88° and 92° from 8200 to about 9700 Mc then rising to 94° at 10,000 Mc. Their VSWR's in the principal planes were less than 1.1 from 9000 to 10,000 Mc, but from 8200 to 9000 Mc plates 9 and 10 were better matched than was plate 4.

For a half-wave plate, a 1.250-inch center section was used with taper 12. The VSWR was less than 1.2 over the entire band and less than 1.1 from 8750 to 10,000 Mc. Its differential phase shift varied from 176° to 186° and was 178° at 9375 Mc. Designs and performances of these four plates are shown in Figure 8.

Power breakdown tests were made on all the quarter-wave and half-wave plate designs. For this purpose a magnetron r-f generator having a peak output of 180 kw was employed. The generator was operated at 1000 cycles repetition rate with a pulse length of 1 microsecond. Under these conditions there was no evidence of breakdown with the plates in either the transverse or the parallel position.

ROTARY PHASE SHIFTER

Half-wave plate 12 and quarter-wave plate 4 were incorporated in a rotary phase shifter (Figure 9) similar to one described by Fox.^{5,6} This instrument consists of a rotatable half-wave plate mounted between two quarter-wave plates which are at 45° to the incident linearly polarized wave. Tapered resistance cards are placed in the transition sections to absorb any cross-polarized wave on input or output.

Ideally, the first quarter-wave plate converts the incident vertical linear polarization to right-hand circular polarization; the half-wave plate changes this to left-hand circular polarization, its phase being determined by the angle of rotation of the plate. Finally, the second quarter-wave plate converts the left-hand circular back to vertical linear polarization. The principal value of this phase shifter is that the phase shift in degrees equals twice the mechanical angle of rotation of the half-wave plate in degrees.

The linearity of the phase shift versus rotation is relatively insensitive to errors either in the differential phase shifts or in the angular positions of the plates. As is shown in Appendix A, these errors contribute at most an error of the second order to the phase of the vertically polarized output. First-order errors are horizontally polarized on output and are absorbed in the resistance card in the transition section.

Two rotary phase shifters of this design were calibrated by a method described in Appendix B. At a frequency of 8432 Mc, the maximum deviation from linearity of each was less than $\pm 1.2^\circ$; at 8910 Mc, less than $\pm 0.6^\circ$; at 9375 Mc, less than $\pm 0.5^\circ$; and at 9925 Mc, less than $\pm 1.6^\circ$. Curves showing the deviation from linearity versus angle of rotation at 9375 Mc are shown in Figure 10. One of these phase shifters was tested for maximum and minimum VSWR over the band by rotating the half-wave plate to angles of maximum and minimum reflection. The results, given in Figure 11, show the maximum VSWR to be less than 1.23 from 8950 to 10,000 Mc.

5

Fox, A. G., "An Adjustable Waveguide Phase Changer," Proc. IRE, 35:1489-1498, Dec. 1947

6

Fox, A. G., US Patent 2,438,119

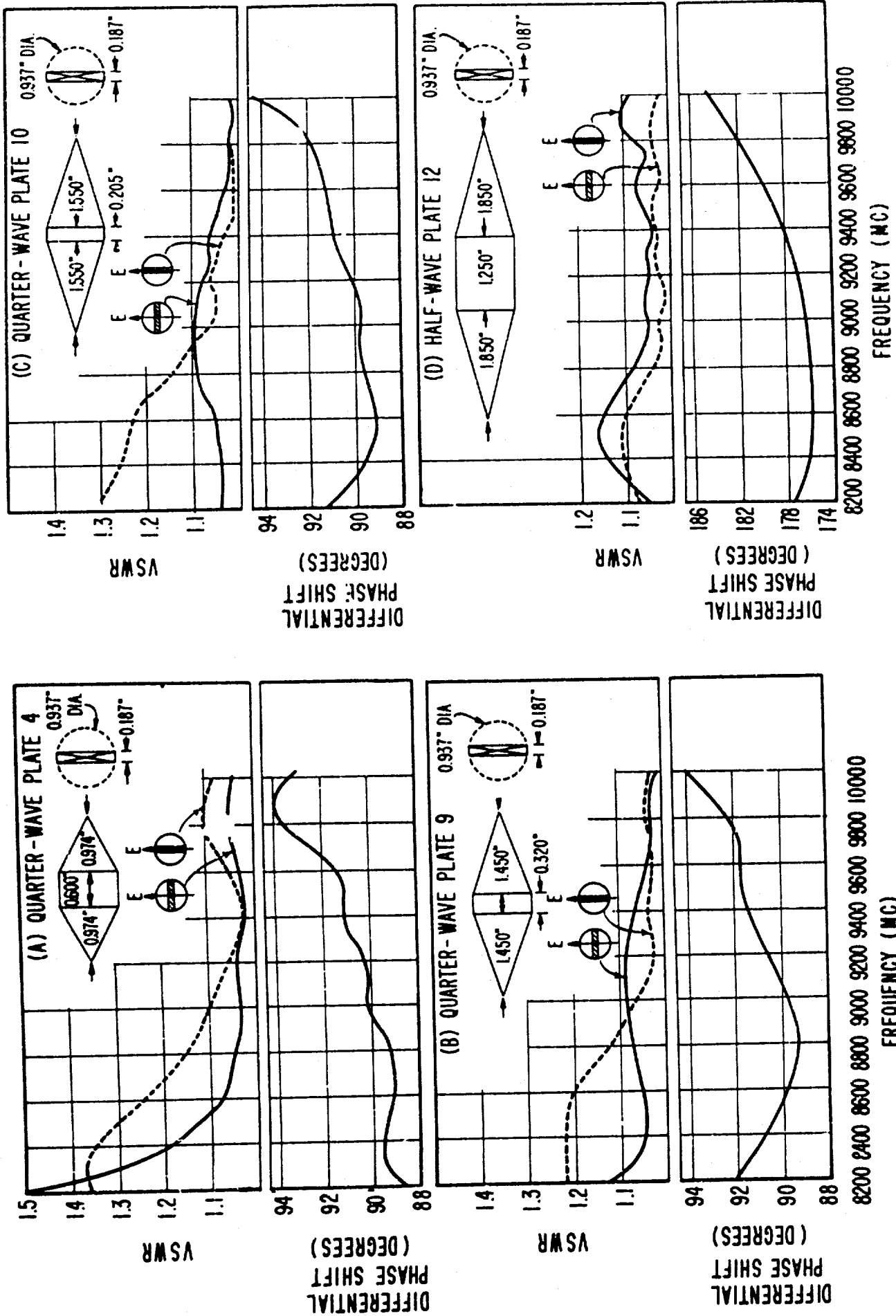

Figure 8 - Designs and performances of quarter- and half-wave plates



Figure 9 - Rotary phase shifter

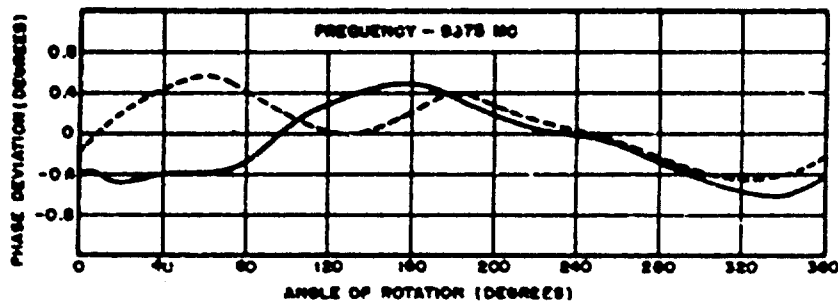

Figure 10 - Deviation from linearity for two rotary phase shifters

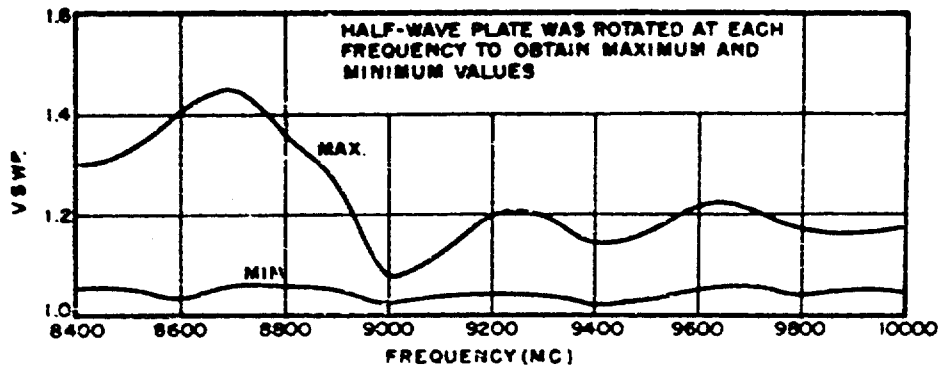

Figure 11 - Voltage standing-wave ratio of rotary phase shifter. The half-wave plate was rotated at each frequency to obtain maximum and minimum values.

PHASE-SHIFTLESS ATTENUATOR

An interesting application of the rotary phase shifter lies in its use in the phase-shiftless attenuator which is shown in Figure 12. Power from the oscillator is split by an H-plane tee (a magic tee is shown in the photograph), passes through the arms, each of which contains a rotary phase shifter and a variable attenuator, and is recombined in a magic tee. The phase shifters are geared to rotate in opposite directions, so at some angular position, say θ_0 , the waves (which have been adjusted to be of equal amplitude) arrive at the magic tee in phase and all the power passes out the H-arm. It may readily be shown that if the E-arm is terminated in a matched load, then for any other position θ the signal in the H-arm is of constant phase (except for a 180° change in phase on passing through $\theta = \theta_0 \pm (\pi/2)$) and of amplitude proportional to $\cos^2 (\theta - \theta_0)$.

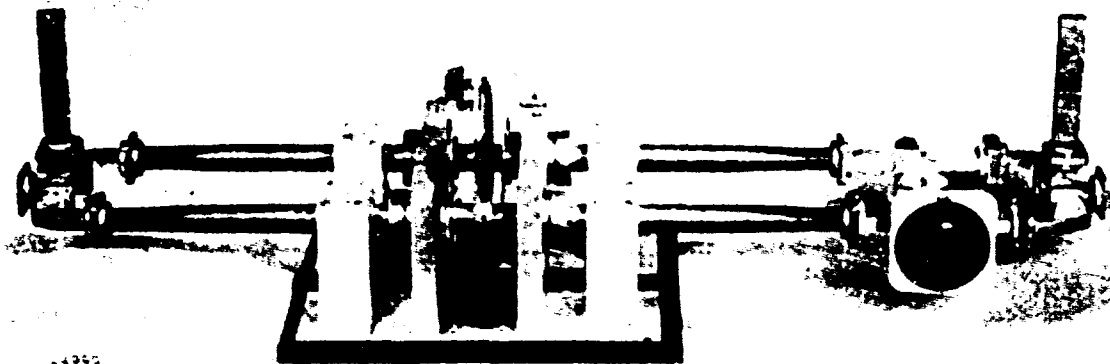

Figure 12 - Phase-shiftless attenuator

A check on the attenuation versus angular position showed the deviation from the theoretical values to be less than 0.1 db over the range 0- to 30-db attenuation. From 0 to 20 db, the phase of the output varied by less than 0.2° ; beyond this range the errors inherent in the method of calibration became too great to permit accurate measurement.

SPECIAL INSTRUMENTATION

In the course of this study, some equipment was built which may be of interest. For waveguide used in VSWR measurements, standard 0.064-inch wall tubing of inside diameter 0.937 inch was found to be sufficiently accurate, but any circular guide used in differential phase-shift measurements was bored to a tolerance of 0.0005 inch in roundness to minimize the phase-shifting effects of elliptical waveguide. An analysis of the differential phase shift due to slightly noncircular waveguide is contained in Appendix C.

Circular choke and flange couplings, shown in Figure 13, were designed to provide, in addition to the usual electrical properties, a bearing surface for rotation of one waveguide with respect to another. Tests on the couplings showed the VSWR to be less than 1.01 over the entire frequency range.

The electroformed rectangular-to-circular waveguide transitions (Figure 14), using a 4-inch taper, had a VSWR less than 1.1 over the band. A tapered resistance card was placed in the circular portion of each transition, perpendicular to the electric field in the rectangular waveguide, to absorb any cross-polarized component. This card had no noticeable effect on the principal polarization.

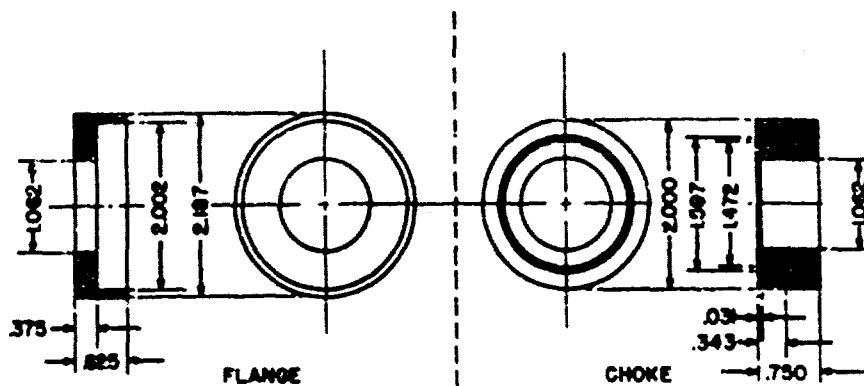

Figure 13 - Circular choke and flange couplings for X-band circular waveguide

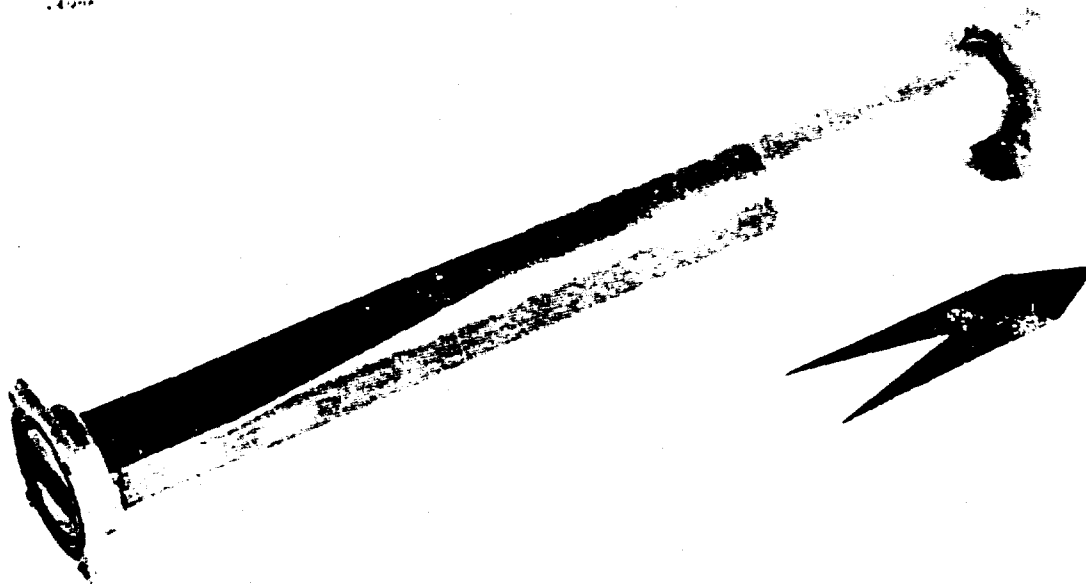

Figure 14 - Rectangular-to-circular waveguide transition

A standing-wave detector (Figure 15) was constructed for impedance measurements and for the measurement of guide wavelength in slab-loaded sections of guide. To achieve the accuracy required for the latter purpose, the slot was made long enough to permit the observation of three minima at the longest wavelength and a long-travel vernier indicator was used. Since this instrument could be rotated, considerable care had to be exercised in aligning it with respect to the linearly polarized field inside the waveguide, so that the slot would not radiate.

The most satisfactory matched load for a linearly polarized wave was an assembly of several tapered resistance cards (Figure 16) at least 12 inches long aligned with the incident electric field. Its VSWR was less than 1.03 over the band. For waves of arbitrary polarization, various loads made of tapered resistance cards were abandoned in favor of a conical wooden load (Figure 16) which had a VSWR of less than 1.05. This load was 14-3/4 inches long with a 12-inch tapered portion.

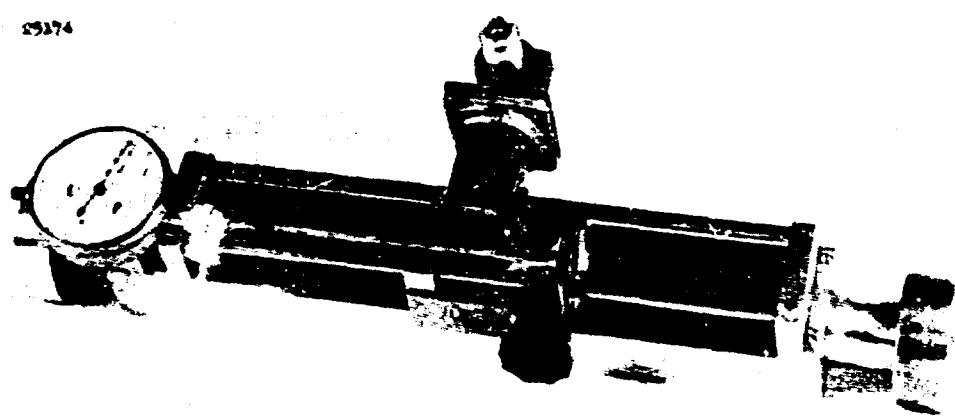

Figure 15 - Circular waveguide standing-wave detector

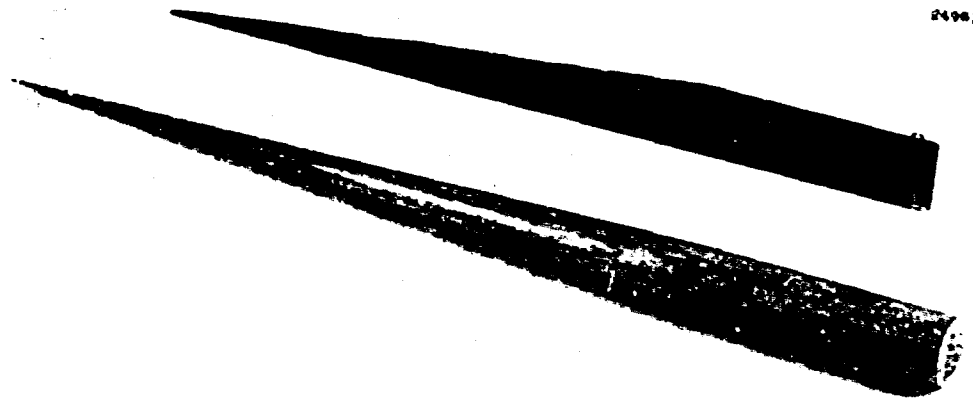
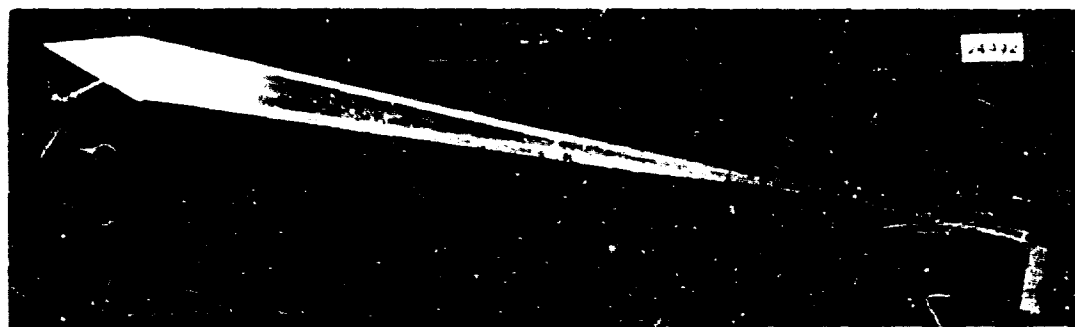
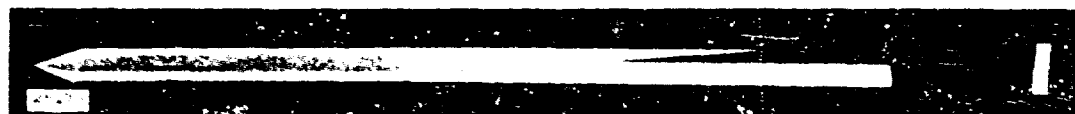

Figure 16 - Matched loads for circular waveguide



(a) parallel mode



(b) transverse mode

Figure 17 - Isolating terminations for dielectric tapers

The isolating terminations used in the measurement of the reflections from tapered slabs are shown in Figure 17. For the parallel mode, the termination consisted of two tapered resistance cards 13 inches long between which the slab was placed. For the transverse mode, the load was a tapered card inserted through a slot in a 3/16-inch-thick slab which was butted against the test slab. The maximum VSWR of each in the 8200- to 10,000-Mc band was 1.03.

ACKNOWLEDGMENT

The authors wish to acknowledge the work of Mr. P. A. Portmann, formerly of the Antenna Research Branch, who started this project and who designed most of the special equipment that was used. Also thanks are due Mr. V. V. Smith and Mr. C. Banks for their assistance in taking laboratory measurements.

APPENDIX A
Errors in the Rotary Phase Shifter

It was stated in the description of the rotary phase shifter that the deviation from linearity of the phase shift versus rotation depended only to the second order on variations in the phase shift and angular positions of the quarter- and half-wave plates. This will be demonstrated by a consideration of the circularly polarized waves set up by the plates in the circular guide.

In Figure A1, the angular positions of the quarter-wave plates are given by $\theta_1 = \pi/4 + \epsilon_1$ and $\theta_3 = \pi/4 + \epsilon_3$ and the differential phase shifts of the plates by $\phi_1 = \pi/2 + \delta_1$, $\phi_2 = \pi + \delta_2$, and $\phi_3 = \pi/2 + \delta_3$, respectively. These plates will do the following:

1. The first quarter-wave plate will convert a vertically polarized wave of unit amplitude to a right-hand circularly polarized wave of amplitude a_1 and a left-hand circularly polarized wave of amplitude b_1 .
2. The half-wave plate changes an incident left-hand (or right-hand) circularly polarized wave of unit amplitude to a right-hand (or left-hand) circularly polarized wave of amplitude a_2 and a left-hand (or right-hand) circularly polarized wave of amplitude b_2 .
3. The second quarter-wave plate changes a right-hand (or left-hand) circularly polarized wave of unit amplitude to a horizontally (or vertically) polarized wave of amplitude a_3 and a vertically (or horizontally) polarized wave of amplitude b_3 .

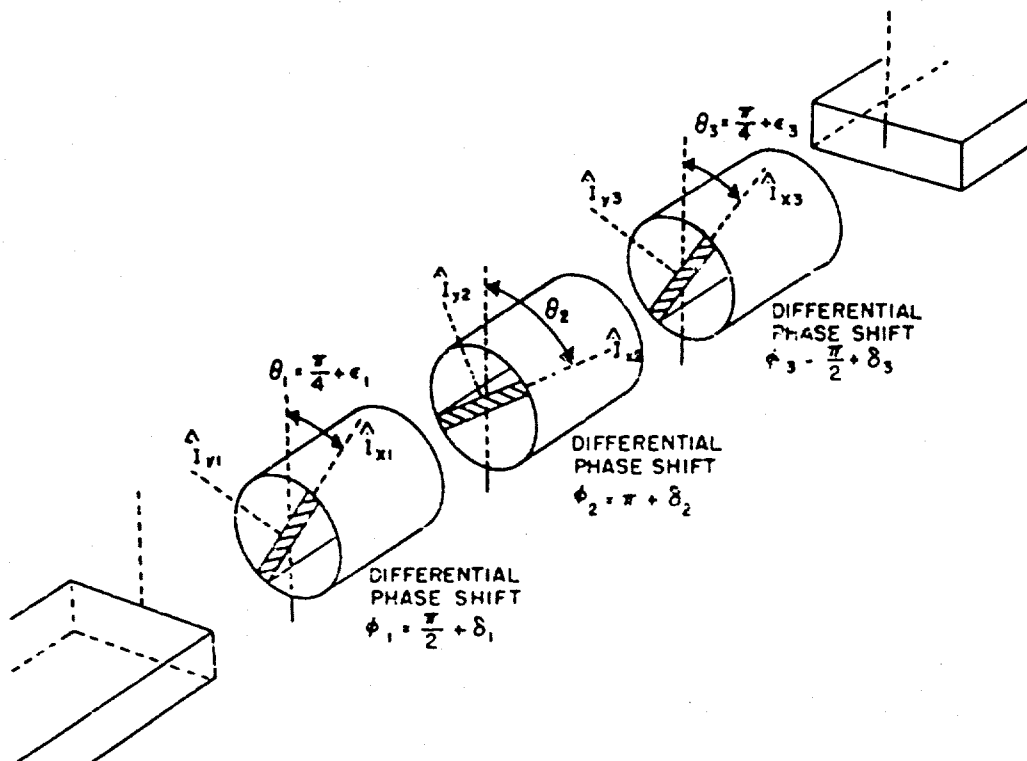

Figure A1 - Schematic diagram of rotary phase shifter

Hence the magnitudes of the eight components of the output of the rotary phase shifter are:

$$\begin{aligned} \text{VERTICAL: } & a_1 a_2 a_3, a_1 b_2 b_3, b_1 a_2 b_3, b_1 b_2 a_3 \\ \text{HORIZONTAL: } & b_1 b_2 b_3, b_1 a_2 a_3, a_1 b_2 a_3, a_1 a_2 b_3 \end{aligned}$$

Since the horizontal component is absorbed in the attenuator card in the transition section, only the vertical components need be considered. The desired component is of constant amplitude $a_1 a_2 a_3$ and, as in the perfect rotary phase shifter, of phase varying as twice the angle of rotation of the half-wave plate. The linearity of the resultant output depends upon the amplitudes and relative phases of this component and the unwanted vertical components. In the worst possible case, the unwanted component is of amplitude $a_1 b_2 b_3 + b_1 a_2 b_3 + b_1 b_2 a_3$ and is 90° out of phase with $a_1 a_2 a_3$. To find the relative amplitudes of these components and hence the maximum phase error, the a 's and b 's are expressed in terms of the errors in phase shift and position of the three plates.

If \hat{x}_1 and \hat{y}_1 are unit vectors respectively parallel to and normal to the first quarter-wave plate, the incident vertically polarized wave I_1 is

$$I_1 = \cos \theta_1 \hat{x}_1 + \sin \theta_1 \hat{y}_1,$$

and the output O_1 is

$$O_1 = \sin \theta_1 \hat{y}_1 + j \cos \theta_1 e^{j\delta_1} \hat{x}_1.$$

When expressed as the sum of two circularly polarized waves, the output is

$$O_1 = \alpha_1 (\hat{y}_1 + j \hat{x}_1) + \beta_1 (\hat{y}_1 - j \hat{x}_1).$$

Hence

$$\alpha_1 = \frac{1}{2} \left(\sin \theta_1 + \cos \theta_1 e^{j\delta_1} \right)$$

$$\beta_1 = \frac{1}{2} \left(\sin \theta_1 - \cos \theta_1 e^{j\delta_1} \right)$$

and

$$a_1 = |\alpha_1| = \frac{1}{2} \left(1 + \sin 2\theta_1 \cos \delta_1 \right)^{\frac{1}{2}} = \frac{1}{2} \left(1 + \cos 2\epsilon_1 \cos \delta_1 \right)^{\frac{1}{2}}$$

$$b_1 = |\beta_1| = \frac{1}{2} \left(1 - \sin 2\theta_1 \cos \delta_1 \right)^{\frac{1}{2}} = \frac{1}{2} \left(1 - \cos 2\epsilon_1 \cos \delta_1 \right)^{\frac{1}{2}}$$

It can be shown in the same manner that

$$a_3 = \frac{1}{2} \left(1 + \cos 2\epsilon_3 \cos \delta_3 \right)^{\frac{1}{2}}$$

$$b_3 = \frac{1}{2} \left(1 - \cos 2\epsilon_3 \cos \delta_3 \right)^{\frac{1}{2}}$$

and

$$a_2 = \cos \frac{\delta_2}{2}$$

$$b_2 = \sin \frac{\delta_2}{2}$$

We find on substitution that the amplitude A of the unwanted vertical component is at most

$$A = a_1 a_2 a_3 \left\{ \tan \frac{\delta_2}{2} \sqrt{\frac{1 - \cos 2\epsilon_1 \cos \delta_1}{1 + \cos 2\epsilon_1 \cos \delta_1}} + \tan \frac{\delta_2}{2} \sqrt{\frac{1 - \cos 2\epsilon_3 \cos \delta_3}{1 + \cos 2\epsilon_3 \cos \delta_3}} \right. \\ \left. + \sqrt{\frac{1 - \cos 2\epsilon_1 \cos \delta_1}{1 + \cos 2\epsilon_1 \cos \delta_1}} \sqrt{\frac{1 - \cos 2\epsilon_3 \cos \delta_3}{1 + \cos 2\epsilon_3 \cos \delta_3}} \right\}.$$

The quantity in brackets is of the second order in δ_1 , δ_2 , δ_3 , $2\epsilon_1$, and $2\epsilon_3$ as long as these quantities are in the range in which the sine of the angle may be replaced by the angle.

The maximum deviation from linearity is given by

$$\phi = \tan^{-1} \frac{A}{a_1 a_2 a_3}$$

As an example, if the errors in position ϵ_1 and ϵ_3 are 1° , and the errors in differential phase shift are $\delta_1 = \delta_3 = 5^\circ$ and $\delta_2 = 10^\circ$, the deviation from linearity will be less than 21 minutes.

APPENDIX B

Calibration of the Rotary Phase Shifter

The deviation from linearity of the phase shift versus rotation for a rotary phase shifter was measured by using a technique developed by P. G. Smith.⁷ The experimental setup is shown in Figure B1. A variable attenuator and the phase shifter which is to be tested are in arm A. In arm B, in addition to a second phase shifter and attenuator, there is a section of slotted waveguide to allow the insertion of a small dielectric flap. With the flap removed, the arms are balanced to get a null in the detector by adjusting the variable attenuators and one of the phase shifters. The flap is then inserted, adding an incremental phase shift δ to arm B, and the arms are rebalanced by turning phase shifter A through an angle ϕ_1 . The flap is again removed and phase shifter B is adjusted to give a null in the detector. The flap is again inserted and phase shifter A is turned through angle ϕ_2 to balance the arms. The procedure continues in this manner.

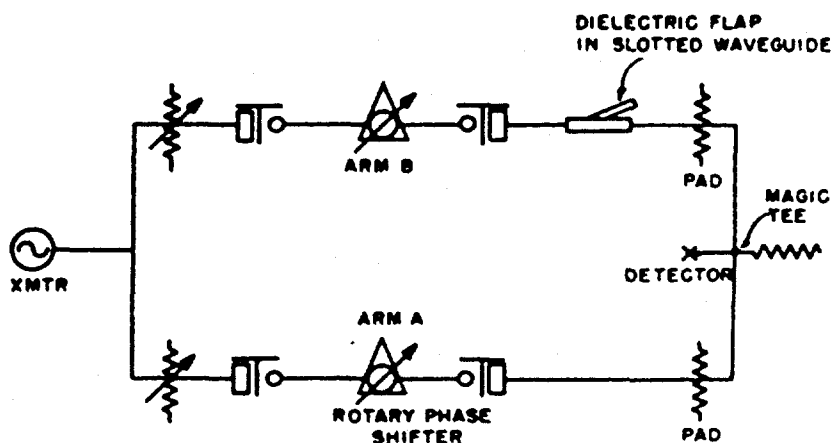

Figure B1 - Setup used in calibrating a rotary phase shifter

If the phase shifter under test were exactly linear, the incremental phase shift δ would be given by

$$\delta = \frac{2}{n} (\phi_1 + \phi_2 + \dots + \phi_n)$$

and could therefore be determined to a high degree of accuracy by making a sufficient number of insertions. The same method of finding δ can be used, even for an imperfect phase shifter, by adjusting the dielectric flap so that after n insertions, the phase shifter has been turned through very nearly some multiple of 360° .

When this value of δ is used, the deviation from linearity can be shown by plotting the error in phase shift, $2(\phi_1 + \phi_2 + \dots + \phi_K) - K\delta$, against the angle turned, $\phi_1 + \phi_2 + \dots + \phi_K$. It should be noted that because of the duality of the setup, phase shifter B can be calibrated simultaneously with A by exactly the same procedure.

⁷ Smith, P. G., MIT, Masters Thesis, 1948

* * *

APPENDIX C Errors Caused by Slightly Elliptical Waveguide

One of the sources of error encountered in measuring differential phase shift is the noncircularity of most stock waveguide. As a consequence, the guide wavelength of a mode is no longer independent of its orientation so the unloaded waveguide can itself cause a differential phase shift. An estimate of the magnitude of this effect can be obtained by assuming the guide to be elliptical with the basic modes being the OT_{E11} (odd) and ET_{E11} (even). Since the guide is almost circular, we can determine the guide wavelengths of the basic modes by finding the change in cutoff wavelength, λ_C , resulting from a slight deformation of the circular guide.

For these modes, the following relation holds:⁸

$$\frac{1}{S} \frac{d\lambda_C}{de} \Big|_{e=0} = \pm 0.04 \begin{cases} + \text{ for even mode} \\ - \text{ for odd mode} \end{cases}$$

where

S = perimeter of the ellipse

e = eccentricity = $\sqrt{\frac{a^2 - b^2}{a^2}}$

a = semimajor axis

b = semiminor axis

Hence the basic cutoff wavelengths become (approximately)

$$\begin{cases} \lambda_C \text{ (even)} = \lambda_C \text{ (circular)} + \Delta\lambda_C = \lambda_C + (0.04) (\Delta e) (S) \\ \lambda_C \text{ (odd)} = \lambda_C \text{ (circular)} - \Delta\lambda_C = \lambda_C - (0.04) (\Delta e) (S) \end{cases}$$

The differential phase shift per unit length is

$$\Delta\phi = 360^\circ \left(\frac{1}{\lambda_g \text{ (even)}} - \frac{1}{\lambda_g \text{ (odd)}} \right) = \frac{360^\circ}{\lambda_0} \left\{ \sqrt{1 - \frac{\lambda_0^2}{(\lambda_C + \Delta\lambda_C)^2}} - \sqrt{1 - \frac{\lambda_0^2}{(\lambda_C - \Delta\lambda_C)^2}} \right\} = \frac{2\lambda_g (\Delta\lambda_C) 360^\circ}{\lambda_C^3} = \frac{28.8 \lambda_g (\Delta e) S}{\lambda_C^3}$$

⁸ Formula obtained from a consideration of the slope at zero ellipticity of the cutoff wavelength graph of elliptical waveguide given by L. J. C. , J. Appl. Phys. 9:583-591, September 1938

Let $\delta = a - b$; then, if $\frac{\delta}{a}$ is small, $S \approx 2\pi a$ and $\Delta e \approx \sqrt{\frac{2\delta}{a}}$ so that finally

$$\Delta\phi \approx \frac{180 \lambda_g \sqrt{2a\delta}}{\lambda_C^3} \text{ degrees per unit length.}$$

For the circular waveguide of 0.937- inch id:

$$a = 1.19 \text{ cm}$$

$$\lambda_C = 4.063 \text{ cm}$$

so

$$\Delta\phi \approx 2.9 \lambda_g \sqrt{2\delta} \text{ degrees/cm.}$$

As a numerical example, if the waveguide is 0.001 inch out of round ($2\delta = 0.001$ inch = 0.0025 cm) and of elliptical cross section, its differential phase shift per unit length at a wavelength of 3.20 cm would be approximately 0.75 degrees per cm. This illustrates the necessity of holding a close tolerance on the roundness of the guide.

* * *

Armed Services Technical Information Agency

AD

PLEASE RETURN THIS COPY TO:

**ARMED SERVICES TECHNICAL INFORMATION AGENCY
DOCUMENT SERVICE CENTER
Knott Building, Dayton 2, Ohio**

Because of our limited supply you are requested to return this copy as soon as it has served your purpose so that it may be made available to others for reference use. Your cooperation will be appreciated.

24766

NOTICE: WHEN GOVERNMENT OR OTHER DRAWINGS, SPECIFICATIONS OR OTHER DATA ARE USED FOR ANY PURPOSE OTHER THAN IN CONNECTION WITH A DEFINITELY RELATED GOVERNMENT PROCUREMENT OPERATION, THE U. S. GOVERNMENT THEREBY INCURS NO RESPONSIBILITY, NOR ANY OBLIGATION WHATSOEVER; AND THE FACT THAT THE GOVERNMENT MAY HAVE FORMULATED, FURNISHED, OR IN ANY WAY SUPPLIED THE SAID DRAWINGS, SPECIFICATIONS, OR OTHER DATA IS NOT TO BE REGARDED BY IMPLICATION OR OTHERWISE AS IN ANY MANNER LICENSING THE HOLDER OR ANY OTHER PERSON OR CORPORATION, OR CONVEYING ANY RIGHTS OR PERMISSION TO MANUFACTURE, USE OR SELL ANY PATENTED INVENTION THAT MAY IN ANY WAY BE RELATED THERETO.

Reproduced by

DOCUMENT SERVICE CENTER

KNOTT BUILDING, DAYTON, 2, OHIO

REPRODUCED FROM
BEST AVAILABLE COPY

REPRODUCED FROM
BEST AVAILABLE COPY

UNCLASSIFIED

**Naval Research Laboratory
Technical Library
Research Reports Section**

DATE: October 15, 2003
FROM: Mary Templeman, Code 5596.3
TO: Code 5300 Paul Hughes
C: Tina Smallwood, Code 1221.1 *to 10/28/03*
SUBJ: Review of NRL Memo Report

Dear Sir/Madam:

Please review ~~NRL~~ Report 4218 for:

- Possible Distribution Statement
- Possible Change in Classification

Thank you,

Mary Templeman
(202)767-3425
maryt@library.nrl.navy.mil

The subject report can be:

- Changed to Distribution A (Unlimited)
- Changed to Classification _____
- Other:

Jaganmohan Bhas 10-22-03
Signature CODE 5317 Date

AN (1) AD- 024 766/XAG
CI (3) (U)
CA (5) NAVAL RESEARCH LAB WASHINGTON D C
TI (6) DIELECTRIC QUARTER-WAVE AND HALF-WAVE PLATES IN CIRCULAR
WAVEGUIDE
AU (10) BROWN,R.M.
SIMMONS,A.J.
RD (11) 10 Nov 1953
PG (12) 21 Pages
RS (14) NRL-4218
RC (20) Unclassified report
DE (23) *PHASE SHIFT CIRCUITS, *WAVEGUIDES
DESIGN
DC (24) (U)
DL (33) 02
CC (35) 251950

APPROVED FOR PUBLIC
RELEASE - DISTRIBUTION
UNLIMITED