

AD No ~~22274~~
ASTIA FILE COPY

Technical Report to the Office of Naval Research

Project NR-051-258

**APPLICATIONS OF VOLTAMMETRY AT CONSTANT
CURRENT IN CHEMICAL KINETICS**

by

Paul Delahay

Report No. 14

Technical Report
to the
Office of Naval Research

Report No 14
Project NR-051-258

APPLICATIONS OF VOLTAMMETRY AT CONSTANT CURRENT
IN CHEMICAL KINETICS

by
PAUL DELAHAY

December 1953
Department of Chemistry
Louisiana State University
Baton Rouge 3, Louisiana

DISTRIBUTION LIST FOR TECHNICAL REPORTS

<u>No. of Copies</u>	<u>Addressee</u>
1	Commanding Officer Office of Naval Research Branch Office 150 Causeway Street Boston, Massachusetts
2	Commanding Officer Office of Naval Research Branch Office The John Crerar Library Building 86 E. Randolph Street Tenth Floor Chicago 1, Illinois
1	Commanding Officer Office of Naval Research Branch Office 346 Broadway New York 13, New York
1	Commanding Officer Office of Naval Research Branch Office 1000 Geary Street San Francisco 9, California
1	Commanding Officer Office of Naval Research Branch Office 1030 N. Green Street Pasadena 1, California
2	Officer-in-Charge Office of Naval Research Branch Office Navy Number 100 Fleet Post Office New York, New York
6	Director, Naval Research Laboratory Washington 25, D. C. Attention: Technical Information Officer
2	Chief of Naval Research Office of Naval Research Washington 25, D. C. Attention: Chemistry Branch
5	ASTIA Document Service Center Knott Building Dayton 2, Ohio
1	Dr. Ralph G. H. Siu, Research Director General Laboratories, QM Depot 2800 S. 20th Street Philadelphia 45, Pennsylvania

<u>No. of Copies</u>	<u>Addressee</u>
1	Dr. Warren Stubblebine, Research Director Chemical and Plastics Section, RDB-MPD Quartermaster General's Office Washington 25, D. C.
1	Dr. A. Stuart Hunter, Tech. Director Research and Development Branch MPD Quartermaster General's Office Washington 25, D. C.
1	Office of Technical Services Department of Commerce Washington 25, D. C.
1	Dr. A. Weisler Department of the Army Office of the Chief of Ordnance Washington 25, D. C. Attn: ORDTB-PS
1	Research and Development Group Logistics Division, General Staff Department of the Army Washington 25, D. C. Attn: Dr. W. T. Read, Scientific Adviser
2	Director, Naval Research Laboratory Washington 25, D. C. Attention: Chemistry Division
2	Chief of the Bureau of Ships Navy Department Washington 25, D. C. Attention: Code 340
2	Chief of the Bureau of Aeronautics Navy Department Washington 25, D. C. Attention: Code TD-4
2	Chief of the Bureau of Ordnance Navy Department Washington 25, D. C. Attention: Code Rexd
1	Office of the Secretary of Defense Pentagon Room 3D1041 Washington 25, D. C. Attention: Library Branch (R+D)
1	Dr. A. G. Horney Office Scientific Research R and D Command USAF Box 1395 Baltimore, Maryland

<u>No. of Copies</u>	<u>Addressee</u>
1	Dr. H. A. Zahl, Tech. Director Signal Corps Engineering Laboratories Fort Monmouth, New Jersey
1	U. S. Naval Radiological Defense Laboratory San Francisco 24, California Attention: Technical Library
1	Naval Ordnance Test Station (Inyokern) China Lake, California Attention: Head, Chemistry Division
1	Office of Ordnance Research 2127 Myrtle Drive Durham, North Carolina
1	Technical Command Chemical Corps Chemical Center, Maryland
1	U. S. Atomic Energy Commission Research Division Washington 25, D. C.
1	U. S. Atomic Energy Commission Chemistry Division Brookhaven National Laboratory Upton, New York
1	U. S. Atomic Energy Commission Library Branch, Tech. Information ORR P. O. Box 5 Oak Ridge, Tennessee
1	Dr. A. E. Remick Department of Chemistry Wayne University Detroit 1, Michigan
1	Dr. Frank Hovorka Department of Chemistry Western Reserve University Cleveland 6, Ohio
1	Dr. David C. Grahame Department of Chemistry Amherst College Amherst, Massachusetts

DISTRIBUTION LIST FOR TECHNICAL REPORTS

Page IV

<u>No. of Copies</u>	<u>Addressee</u>
1	Dr. P. J. Elving Department of Chemistry University of Michigan Ann Arbor, Michigan
1	Dr. N. H. Furman Department of Chemistry Princeton University Princeton, New Jersey
1	Dr. I. M. Kolthoff Department of Chemistry University of Minnesota Minneapolis 14, Minnesota
1	Dr. H. A. Laitinen Department of Chemistry University of Illinois Urbana, Illinois
1	Dr. Louis Meites Department of Chemistry Yale University New Haven, Connecticut
1	Dr. O. H. Muller Department of Physiology Syracuse University Syracuse, New York
1	Dr. Pierre Van Rysselberghe Department of Chemistry University of Oregon Eugene, Oregon
1	Dr. Stanley Mawzonek Department of Chemistry State University of Iowa Iowa City, Iowa
1	Dr. J. J. Lingane Department of Chemistry Harvard University Cambridge 38, Massachusetts
1	Dr. Leon O. Morgan Department of Chemistry University of Texas Austin, Texas

ABSTRACT

This paper was prepared for the forthcoming Discussion of the Faraday Society on fast reactions (Birmingham, April 1954).

Various kinetic and catalytic processes in voltammetry at constant current are treated, and theoretical and experimental methods for the determination of rate constants are presented. The conditions under which the method can be applied are examined, and potentialities of the constant current method in chemical kinetics are compared with those of polarography.

The study of electrode processes in which electron transfer is coupled with a chemical reaction enables one to study the kinetics of certain reactions. Such studies can be made by a variety of methods in which either the electrode potential or the electrolysis current is controlled. This paper deals with the latter type of method for the particular case in which the following conditions are fulfilled: (1) The current is kept constant during electrolysis; (2) The solution is unstirred and linear diffusion is the sole mode of mass transfer, e.g. migration and convection can be neglected; a large excess of supporting electrolyte is present and the duration of electrolysis is relatively short - one minute or less. This method, which we shall refer to as "voltammetry at constant current," has seldom been applied although it is one of the oldest electrochemical methods. Its origin can be traced to the work of Weber¹ (1879), but it is only about 1900 that application was made by Sand², Cottrell³, and Karaoglarsoff⁴, in the determination of diffusion coefficients. The method was applied more recently by various authors^{5,6} in the study of electrode processes. Theoretical and experimental contributions have been made by the writer and co-workers⁷⁻¹¹.

The following types of process will be considered:

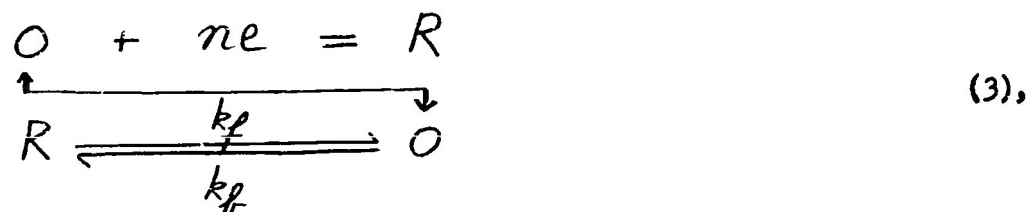
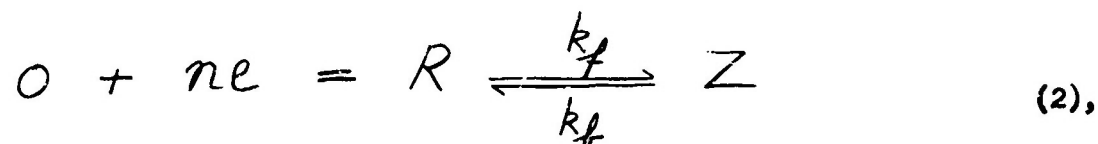

where O and R symbolize the substances involved in the electron transfer; the k 's are rate constants; and Z is a soluble substance which is not reduced or oxidized directly. It will be assumed that substance R in processes (1) and (2) is soluble either in solution or in mercury in the deposition of an amalgam forming metal. Substance R in process (3) is soluble in solution. Substance O is supposed to be soluble. Furthermore, chemical reactions in processes (1) to (3) are assumed to be of the first order. Only cathodic processes will be considered, since the transposition to anodic processes is trivial.

The simple case, represented by the equation



and in which there is no coupled chemical reaction, will be briefly considered to render the discussion of more intricate cases intelligible.

3

PROCESSES WITH DIFFUSION CONTROL

Because of the electrolytic reduction of substance O, there is progressive depletion of this substance at the electrode surface. The variations of the concentration c_0 can be determined by solving Fick's equation for linear diffusion for suitable boundary and initial conditions. Since the electrolysis current is constant, the flux of substance O at the electrode surface is constant. Hence

$$\left(\frac{\partial c_0}{\partial x}\right)_{x=0} = i_0 / n F D_0 \quad (5),$$

where x is the distance from the electrode, c_0 the concentration of substance O, i_0 the current density at the electrode, n the number of electrons in the electrode process, F the faraday, and D_0 the diffusion coefficient of substance O. Condition (5) holds for any value of the time t larger than zero (t , time elapsed since the beginning of electrolysis). The initial condition is $c_0 = c^*$, where c^* is the bulk concentration of substance O, it being assumed that there is no gradient of concentration before electrolysis. Finally, one has $c_0 \rightarrow c^*$ for $x \rightarrow \infty$. The solution of this boundary value problem for $x = 0$ is

$$\left(c_0\right)_{x=0} = c^* - \frac{2 i_0 t^{1/2}}{\pi^{1/2} n F D_0^{1/2}} \quad (6).$$

It is seen from equation (6) that the concentration c_0 decreases during electrolysis. At the transition time τ_d , defined by

$$\tau_d^{1/2} = \frac{\pi^{1/2} n F D_0^{1/2} c^*}{2 i_0} \quad (7),$$

the concentration $(c_0)_{x=0}$ is equal to zero. The potential of the electrode, on which O is reduced, varies then toward more cathodic values until a process other than the

reduction of substance O occurs. This new process may be, for example, the reduction of the supporting electrolyte. The value of potential during electrolysis is obtained by introducing the concentrations of substances O and R in the suitable formula for the electrode potential. This can be done for so-called reversible and irreversible processes. Only reversible processes for which substance R is soluble will be considered here; for irreversible processes see ref.7. .

By solving Fick's equation for c_R one obtains

$$(c_R)_{x=0} = (D_O/D_R)^{1/2} [c^0 - (c_O)_{x=0}] \quad (8)$$

for the case in which c_R is equal to zero before electrolysis. The concentrations c_O and c_R may now be introduced in the Nernst equation, and this yields the following equation for the potential-time curve⁴:

$$E = E_{\tau/4} + \frac{RT}{nF} \ln \frac{c_d^{1/2} - t^{1/2}}{t^{1/2}} \quad (9)$$

with

$$E_{\tau/4} = E^0 + \frac{RT}{nF} \ln \frac{f_O}{f_R} \left(\frac{D_R}{D_O} \right)^{1/2} \quad (10),$$

where E^0 is the standard potential for equilibrium (4), and the f 's are activity coefficients. It follows from (9) that the potential $E_{\tau/4}$ is reached at one fourth of the transition time.

An experimental potential-time, which essentially obeys equation (9), is shown in Fig.1. The transition time is represented by the segment AB. The segments on the right and left sides should be virtually vertical according to equation (9). However, this is not the case, because of the distortion resulting from the charging of the double layer. This effect, which is rather minor, need not be considered any further here.

The study of potential-time curves is very fruitful in electrochemical kinetics, and the determination of transition times may be used to analytical purposes. However, these applications of voltammetry at constant current are beyond the scope of this paper.

**ELECTRON TRANSFER PRECEDED BY A FIRST ORDER CHEMICAL
REACTION**

The transition time for process (2) is determined by the condition $(c_0)_{x=0}$. The concentration of substance O is controlled by the rate of diffusion of this substance and by the kinetics of the transformation $Z \rightleftharpoons O$. Hence, kinetic terms must be introduced in Fick's equation, which then becomes

$$\frac{\partial c_0}{\partial t} = D_0 \frac{\partial^2 c_0}{\partial x^2} + k_f c_Z - k_b c_0 \quad (11),$$

where the k^i 's are formal rate constants. Likewise,

$$\frac{\partial c_Z}{\partial t} = D_Z \frac{\partial^2 c_Z}{\partial x^2} - k_f c_Z + k_b c_0 \quad (12).$$

The boundary condition for substance O is the same as in the case of simple diffusion (equation 5). The boundary condition for Z_1 $(\frac{\partial c_Z}{\partial x})_{x=0} = 0$, expresses that Z is not reduced at the electrode surface (see introduction). Initial conditions are: $c_0^0 / c_Z^0 = K$ and $c_0^0 + c_Z^0 = c^*$, where K is the equilibrium constant for the transformation $Z \rightleftharpoons O$ and c^* is the sum of the bulk concentrations of O and Z. Finally, one has $c_0^0 / c_Z^0 \rightarrow K$ and $c_0 + c_Z \rightarrow c^*$ for $x \rightarrow \infty$.

By solving this boundary value problems and by expressing that $(c_0)_{x=0}$ is equal to zero at the transition time, one obtains⁷

$$i_0 \tau_k^{1/2} = \frac{\pi^{1/2} n F c^0 D^{1/2}}{2} - \frac{\pi^{1/2} i_0}{2K(k_f + k_b)^{1/2}} \operatorname{erf} \left[(k_f + k_b)^{1/2} \tau_k^{1/2} \right] \quad (13),$$

where "erf" symbolizes the error function; τ_k is the transition time; and D is the common value of the diffusion coefficients D_0 and D_R , which are assumed to be equal.

The error function in equation (13) is virtually equal to unity when the argument $(k_f + k_b)^{1/2} \tau_k^{1/2}$ is larger than 2. Under these conditions the product $i_0 \tau_k^{1/2}$ decreases linearly when the current density is increased. The limiting value of $i_0 \tau_k^{1/2}$ for $i_0 = 0$ is simply the quantity $i_0 \tau_d^{1/2}$ (see equation 7) which corresponds to a process purely controlled by diffusion. The product $K(k_f + k_b)^{1/2}$ is readily computed from the slope of the experimentally determined line $i_0 \tau_k^{1/2}$ vs. i_0 . The rate constants k_f and k_b can then be calculated provided that the equilibrium constant K is known. Example of diagrams $i_0 \tau_k^{1/2}$ vs. i_0 will be presented below.

ELECTRON TRANSFER FOLLOWED BY A FIRST ORDER

CHEMICAL REACTION

The transition time for process (2) is not influenced by the transformation $R \rightleftharpoons Z$. However, the position of the potential-time curve in the scale of potentials depends on the kinetics of the chemical transformation $R \rightleftharpoons Z$ in the case of a reversible electrochemical reaction. The potential can be calculated by the Nernst equation provided that the concentrations $(c_0)_{x=0}$ and $(c_R)_{x=0}$ are known. The former is given by equation (6), and the latter is calculated as follows.

The functions c_R and c_Z obey Fick's equation to which kinetic terms are added. A first boundary condition is obtained by expressing that the sum of the

fluxes of substances O and R at the electrode surface is equal to zero. In view of equation (5), this condition is $(\partial c_R / \partial x)_{x=0} = -i_0 / n F D$, D being the common value of the diffusion coefficients D_O and D_R which are assumed to be equal. The second boundary condition is written by noting that substance Z is not reduced or oxidized electrolytically. Hence, $(\partial c_Z / \partial x)_{x=0} = 0$. As initial conditions one can prescribe $c_R = c_Z = 0$ for $t = 0$. As usual, the functions c_R and c_Z are bounded for large values of x , and one has $c_R \rightarrow 0$ and $c_Z \rightarrow 0$ for $x \rightarrow \infty$. The solution of this boundary value problem¹⁰ leads to the following equation of the potential-time curve

$$E = E_{\tau/4} - \frac{RT}{nF} \ln \square + \frac{RT}{nF} \ln \frac{\tau_d^{1/2} - t^{1/2}}{t^{1/2}} \quad (14)$$

with

$$\square = \frac{1}{1+K} + \frac{\pi^{1/2}}{2} \frac{K}{1+K} \frac{\text{erfc} \left[\frac{(k_f + k_b)^{1/2} t^{1/2}}{(k_f + k_b)^{1/2} t^{1/2}} \right]}{(k_f + k_b)^{1/2} t^{1/2}} \quad (15),$$

where K is the equilibrium constant for the transformation $R \rightleftharpoons Z$. Except for the second term on the right-hand side, equation (14) is identical to the corresponding equation for a process purely controlled by diffusion (equation 9).

The rate constant k_f can be determined from the dependence of the potential at time $\tau/4$ on the current density. If the current density is properly adjusted, the argument of the error function in (15) for $t = \tau/4$ is larger than 2, and the potential at time $\tau/4$ is ($K \gg 1, k_f \gg k_b$)

$$E_{t=\tau/4} = E_{\tau/4} + \frac{RT}{nF} \ln \frac{2^{1/2} k_f^{1/2} (\tau/4)^{1/2}}{\pi^{1/2}} \quad (16).$$

Since $\tau^{1/2}$ is inversely proportional to the current density (equation 7), the potential $E_{t=\tau/4}$ is a linear function of the logarithm of the current density. The value of k_f is computed from the slope of the line $E_{t=\tau/4}$ versus $\ln i_0$.

FIRST ORDER CATALYTIC PROCESSES

Because of regeneration of substance O, the transition time for process (3) is larger than in the absence of any catalytic effect. The transition time can again be calculated from the condition $(c_O)_{x=0} = 0$. The concentrations c_O and c_R are solutions of Fick's equation in which kinetic terms are introduced. The first boundary condition expresses that the flux of this substance at the electrode surface is constant (equation 5). The second boundary condition is derived by noting that the sum of the fluxes of substances O and R at $x=0$ is equal to zero. Thus, $(\partial c_R / \partial x)_{x=0} = -i_0 / n F D$, if D_O and D_R are equal. The initial conditions are: $c_O = c^*$, $c_R = 0$. One has also $c_O \rightarrow c^*$ and $c_R \rightarrow 0$ for $x \rightarrow \infty$. The solution of this boundary value problem yields ($k_f \gg k_b$)

$$\left(\frac{\tau_c}{\tau_d}\right)^{1/2} = \frac{2 (k_f \tau_c)^{1/2}}{\pi^{1/2} \operatorname{erfc} [(k_f \tau_c)^{1/2}]} \quad (17),$$

where τ_c is the transition time, τ_d the transition time in the absence of any catalytic process.

The rate constant k_f can be calculated provided that the transition times τ_c and τ_d are known. The time τ_c can be measured, and τ_d can be calculated (equation 7). The value of the function on the right-hand side of (17) is thus known, and the corresponding argument $k_f \tau_c$ - i.e. k_f since τ_c is known - is readily determined from a table of values of the function in equation (17).

The functions on the right-hand of equation (17) becomes infinite when $(k_f \tau_c)^{1/2}$ approaches zero. Since τ_c decreases when the current density is

increased, the ratio ξ_c / ξ_d approaches unity at large current densities. This trend in the variations of ξ_c / ξ_d with current density was observed in the catalytic reduction of titanium (IV) in presence of hydroxylamine (Fig.2)¹⁰. The oxidation of titanium (III) by hydroxylamine, whose kinetics was studied by polarographic and conventional chemical methods by Blazek and Koryta¹², is of the first order with respect to titanium (III) when a large excess of hydroxylamine is present. Hydroxylamine is reduced with the production of NH_2 radical as was demonstrated by Evans and co-workers¹³. These radicals react with oxalic acid¹² in the experimental conditions under which the data of Fig.2 were obtained. The value $k_f = 30 \text{ lit.mol.}^{-1} \text{ sec.}^{-1}$ for 30° was obtained by application of the above treatment. This value is appreciably smaller than the one ($k_f = 42 \text{ lit.mol.}^{-1} \text{ sec.}^{-1}$ for 25°) reported by Blazek and Koryta. This discrepancy probably results from the error made in the determination of transition times on account of the poor definition of the transition time (we repeated the polarographic determinations of Blazek and Koryta and confirmed their results).

EXPERIMENTAL

The apparatus for voltammetry at constant current comprises three essential elements: the electrolytic cell, the constant current power supply, and the potential-time curve recorder. Electrolytic cells generally have three electrodes: the working electrode (e_1), the reference electrode (e_2), and the auxiliary electrode (e_3). Electrode e_1 and e_3 are connected to the constant current power supply, while e_1 and e_2 are connected to the voltage recorder. The working electrode may be a solid (platinum) electrode, a mercury pool electrode, or a dropping mercury electrode. Mercury electrodes are particularly useful because of the possibility of exploring a wide range of potentials. A cell with mercury pool electrode is schematically represented in Fig.3. Various types of cell were designed, and it was finally concluded that the cell of Fig.3 gives the most

reliable results. The main difficulty with mercury pool electrodes is the relatively poor reproducibility of the electrode area. There are two main causes of error in consecutive determinations: (1) Creeping of solution between mercury and the wall of the mercury cup; (2) Variations in the diameter of the mercury cup. These causes of error are greatly minimized in the cell of Fig.3 where the cup - carefully machined on the lathe - is made of a plastic (Lucite) which is not wetted by water. The cup fits a ground glass joint. Mr. Mamantov has verified in a series of determinations that the area is reproducible with a maximum deviation of ± 1.2 per cent and with an average deviation of ± 0.4 per cent. The auxiliary electrode in the cell of Fig.3 is a platinum electrode, and the reference electrode is a saturated calomel electrode of the "industrial type" which is available from pH meter manufacturers. The reference electrode is placed in a sleeve whose tip is very close (less than 1 mm.) to the mercury surface. The error on the potential, which is caused by the ohmic drop between electrodes e_1 and e_2 is then virtually eliminated. Nitrogen is bubbled through the solution when the electrolyte must be freed from dissolved oxygen before electrolysis.

The general layout of the apparatus is shown in Fig.4. The cell, in series with resistances R_1 and R_2 , is connected to a power supply PS having an output voltage of 200-300 volts. The current, which is virtually controlled by the ohmic drop in resistance R_1 , remains almost constant during electrolysis under these conditions. A power supply with electronic regulation of current can, of course, be used. The current intensity is determined by measuring the ohmic drop in resistance R_2 with potentiometer P_1 . The voltage across electrodes e_1 and e_2 is applied to a pen-and-ink recorder having a fast response (1 sec. for full scale deflection) and a high chart speed (480 inches per hour). A potentiometer P_2 is inserted in the input circuit of the recorder to compensate any fraction of the voltage applied to the recorder.

The dropping mercury electrode can be utilized but potential-time curves must be recorded in a small fraction of the drop life; the mass transfer process can

then be treated as linear diffusion toward a stationary electrode. Reproducible results are obtained by synchronizing the recording process with the fall of the drop. The following method utilized by Gierst and Juliard⁶ gives reliable results as we have verified. The mercury drop is dislodged by a magnetic hammer H whose operation is controlled by switch S (Fig.5). This type of mechanical device for controlling the operation of the dropping mercury electrode has been used by various authors¹⁴. The closing of switch S also activates the time relay RL, which, after a given time, closes the electrolysis circuit and activates the driven sweep of a cathode-ray oscillograph. The voltage across the working and reference electrodes is applied to the vertical deflection amplifier of the oscillograph.

APPLICATIONS AND COMPARISON WITH POLAROGRAPHY

Kinetic and catalytic processes can also be studied by polarography, and it is of interest to compare the potentialities of the latter method with those of voltammetry at constant current in chemical kinetics. The polarographic study of these processes is largely due to the Czechoslovak school and, in particular, to Brdicka, Wiesner, and Koutecky. The treatment of kinetic processes of the type represented by equation (1) was developed by Koutecky and Brdicka¹⁵ for the case of linear diffusion and by Koutecky¹⁶ for diffusion at the dropping mercury electrode. The theory of polarographic waves corresponding to process (2) has not been reported thus far, although Kern¹⁷ developed an approximate treatment based on the concept of reaction layer and Kivalo¹⁸ recently announced the publication of a theoretical analysis of this type of process. The treatment of catalytic processes (equation 3) was developed independently by several investigators for conditions of linear diffusion¹⁹, and Koutecky treated the case of the dropping mercury electrode²⁰.

KINETIC PROCESSES REPRESENTED BY EQUATION (1).

In this case, the potentialities of voltammetry at constant current are perhaps greater than in polarography for two reasons: (1) Platinum as well as

mercury electrodes can be utilized, while only mercury electrodes can be used in polarography; (2) Processes, which yield a diffusion current which obeys the Ilkovic equation, may still exhibit the characteristics of a kinetic process in voltammetry at constant current. The latter point requires a few comments.

The Ilkovic equation is essentially applicable when the quantity $(k_f K T)^{1/2}$ is larger than 10 (t drop time). Since t is of the order of 4 seconds and $K = k_f / k_b$, the foregoing conclusion expresses that the transformation Z to O is too rapid to cause any major departure from the Ilkovic equation when the quantity $K k_b^{1/2}$ is larger than $5 \text{ sec.}^{-1/2}$. In voltammetry at constant current the situation is more favorable as one can ascertain by writing equation (13) under the modified form ($K \ll 1, k_f \ll k_b$)

$$\tau_k^{1/2} = \tau_d^{1/2} - \frac{\pi^{1/2}}{2 K k_b^{1/2}} \quad (18),$$

where τ_d is the transition time which would be observed if the transformation Z to O were so rapid as to preclude any kinetic effect. Equation (18) is written for the case in which the current density is so low to allow one to assume that the error function in equation (13) is equal to unity. The shortest transition time, which can be observed without excessive distortion of potential-time curves by the charging of the double layer, is of the order of 1 millisecond⁶. The precision of the measurements is such that a 10 per cent decrease in transition time can be detected as the current density is varied from zero to its value corresponding to a 1 millisecond transition time. Hence, it follows from (18) that a kinetic effect can be detected when the quantity $K k_b^{1/2}$ is smaller than $500 \text{ sec.}^{-1/2}$. This compares favorably with the value of $5 \text{ sec.}^{-1/2}$ for polarography. These considerations are borne out experimentally (see below).

The reactions corresponding to process (1) and which have been studied thus far are not numerous. A typical case is the reduction of various aldoses (dextrose, manose, etc.) which exist predominantly in solution as a nonreducible

kinetic process²²; the nonreducible form is the hydrated aldehyde. The most extensively studied kinetic process of the type represented by equation (1) is the reduction of weak acids whose anions are reduced at more cathodic potentials than the corresponding undissociated acid. The recombination of the anion and hydrogen ion correspond then to the transformation Z to O of equation (1). This recombination process is of the first order when the solution is well buffered. Pyruvic acid is one of the several acids which have been investigated¹⁵. These various studies were all made by polarography, and the application of voltammetry at constant current would add nothing to the information already available.

Another type of reaction, which has not - and in many cases could not - be studied by polarography, is the transformation certain complex ions must undergo before electrolytic reduction or oxidation. Kinetic effects in the reduction of complex ions were first reported by Gierst and Juliard⁶, and further investigation has been made by Berzins⁷ and Mamantov in the author's laboratory. Examples of plots of $(\tau_k / \tau_d)^{1/2}$ versus current are given in Fig.6 for the reduction of various complexes; these data were gathered by Mr. Mamantov. The decrease in $(\tau_k / \tau_d)^{1/2}$ with increasing current density is quite pronounced except for the reduction of zinc tetramine ion (line 1). Application of the foregoing theoretical treatment cannot easily be made because the equilibrium constant for the chemical step (equation 1) preceding electron transfer is not known. Furthermore, the chemical reaction may involve several steps whose kinetics must be taken into account. However, it is not unwise to conclude from the data of Fig.6 that electron transfer is preceded by a chemical transformation in the case of certain complexes. The opposite conclusion is also valid, for example in the case of copper-ethylenediamine complex ions (mainly Cu(en)_2^{++} ; the ration $(\tau_k / \tau_d)^{1/2}$ for the reduction of these complex ions is independent of current density⁷. If the occurrence of a chemical process is postulated, it must be concluded that the rate constant k_p for this reaction is unreasonably high ($10^{26} \text{ sec.}^{-1}$). The calculation of k_p is very approximate, but it indicates that no purely chemical step

ions are not apparent to the author, but voltammetry at constant current might be a tool in the study of the rapid chemical transformation which certain complex ions undergo before electron transfer.

PROCESSES REPRESENTED BY EQUATION (2).

Polarographic evidence for existence of process (2) has only been reported in two cases to the author's knowledge, namely in the oxidation²³ of hydroxychromans and hydroxycoumarans and l-ascorbic acid. Quite a few cases may be encountered in the electrolysis of organic substances, but no experimental data are available at the present.

PROCESSES REPRESENTED BY EQUATION (3).

The occurrence of catalytic processes represented by equation (3) requires fulfillment of conditions which are often not satisfied. Thus, the transformation of R to O may be a dismutation as in the reduction of uranium (VI)²⁴. However, the chemical process (the dismutation) is then of the second order. Substance R may be reoxidized to O by a third substance Z, but the following conditions must be satisfied to enable one to apply the theoretical analysis developed above or the corresponding treatment in polarography: (1) Substance Z must not be reduced or oxidized at the potentials at which substance O is reduced; (2) The reaction $R + Z = O$ must be of the first order with respect to R; (3) A large excess of Z must be present in the electrolyzed solution to render negligible the concentration polarization of Z at the electrode surface. Only condition (3) is easy to fulfill. Catalytic processes have been studied by polarography in the case of the reduction of various substances - for example ferric ion²⁵ - in presence of hydrogen peroxide. This is because hydrogen peroxide is a fairly good oxidizing agent whose electrolytic reduction involves a very large overvoltage (of the order of 2 volts at current densities used in polarography). Other catalytic processes have

been observed in the polarographic reduction of various substances in presence of hydroxylamine¹², perchloric acid²⁶, and concentrated sulfuric acid²⁷. This matter has been reviewed by Kolthoff and Lingane and by Delahay²⁸.

The only advantage of voltammetry at constant current over polarography in the study of catalytic processes is the possibility of using a platinum working electrode: processes which occur at potentials at which mercury is oxidized might still be studied.

In conclusion, the applications of voltammetry at constant current and polarography in chemical kinetics are rather limited if one excludes studies in which these methods are utilized purely as an analytical tool. Only first order processes can be interpreted rigorously because the theoretical analysis of reactions of a higher order requires the solution of nonlinear differential equations; the mathematical treatment involves then more labor (approximation methods) than the problem deserves. However, voltammetry at constant current and polarography can be useful in chemical kinetics in some rather specific cases.

ACKNOWLEDGMENT

The author gladly acknowledges his indebtedness^{ed} to the Office of Naval Research for the support of this investigation.

REFERENCES

- (1) Weber, Wied. Ann., 1879, 7, 536.
- (2) Sand, Phil. Mag., 1901, 1, 45.
- (3) Cottrell, Z. physik. Chem., 1902, 42, 385.
- (4) Karaoglanoff, Z. Elektrochem., 1906, 12, 5.
- (5) Butler and Armstrong, Proc. Roy. Soc., 1933, 139A, 406; Trans. Faraday Soc., 1934, 30, 1173.

- (6) Gierst and Juliard, International Committee of Electrochemical Thermodynamics and Kinetics, Proceedings of the 2nd Meeting, Tamburini, Milan, pp.117 and 279; J. Inorg. Chem., 57, 701 (1953).
- (7) Delahay and Berzins, J. Am. Chem. Soc., 1953, 75, 2486.
- (8) Berzins and Delahay, ibid., 1953, 75, 4205.
- (9) Delahay and Mattax, ibid., 1954, 76, (in course of publication).
- (10) Delahay, Mattax, and Berzins, Technical Report to the Office of Naval Research, Report No 15, Project NR-051-258 (1954). Appendix by Delahay and Mamantov.
- (11) Mattax and Delahay, ibid., Report No 16 (1954).
- (12) Blazek and Koryta, Coll. Czech. Chem. Commun., 1953, 18, 326.
- (13) Davis, Evans, and Higginson, J. Chem. Soc., 1951, 2563.
- (14) Tsimmergahl, Zavodakaya Lab., 1949, 15, 1370; Airey and Smales, Analyst, 1950, 75, 287; Wahlin, Radiometer Polarographica, 1952, 1, 113.
- (15) Koutecky and Brdicka, Coll. Czech. Chem. Commun., 1947, 12, 337.
- (16) Koutecky, Chem. Listy, 1953, 47, 323.
- (17) Kern, J. Am. Chem. Soc., 1953, 75, 2473.
- (18) Kivalo, ibid., 1953, 75, 3286.
- (19) Kern, Thesis, University of California, 1949; Kolthoff and Khalafalla, unpublished investigation; Pospisil, Thesis, Charles University, Prague, 1951; Delahay and Stiehl, J. Am. Chem. Soc., 1952, 74, 3500; Miller, ibid., 1952, 74, 4130.
- (20) Koutecky, Coll. Czech. Chem. Commun., 1953, 18, 311.
- (21) Wiesner, ibid., 1947, 12, 64.
- (22) Vesely and Brdicka, ibid., 1947, 12, 313; Bieber and Trümpler, Helv. chim. Acta, 1947, 30, 706.
- (23) Smith, Kolthoff, Wawzonek, and Ruoff, J. Am. Chem. Soc., 1941, 63, 1018; Vavrin, Coll. Czech. Chem. Commun., 1949, 14, 367.
- (24) Orleman and Kern, J. Am. Chem. Soc., 1953, 75, 3058.
- (25) Kolthoff and Parry, ibid., 1951, 73, 3728.

- (27) Vlcek, Coll. Czech. Chem. Commun., 1951, 16, 465.
- (28) Kolthoff and Lingane, Polarography, Interscience, New York, 2nd Ed., 1952, Vol. I, pp.268-294; Delahay, New Electrochemical Methods, Interscience, New York, 1954, Chapter V (in course of publication).

LIST OF FIGURES

- Fig.1. Potential-time curve for the reduction of 4 m M cadmium ion on a mercury cathode; supporting electrolyte, 1 M potassium nitrate. Increasing time are from right to left.
- Fig.2. Variations of $(\zeta/\zeta_d)^{1/2}$ with current for the catalytic reduction of 1 m M titanium (IV) in presence of 1.5 M hydroxylamine and 0.2 M oxalic acid. Electrode area, 0.030 cm.². Temperature, 30° ± 1.
- Fig.3. Cell with mercury pool electrode.
- Fig.4. Schematic diagram of apparatus - Electrolysis with mercury pool electrode.
- Fig.5. Schematic diagram of apparatus - Electrolysis with dropping mercury electrode.
- Fig.6. Variations of $(\zeta_R/\zeta_d)^{1/2}$ with current for the reduction of complexes. Curve 1: 1 m M zinc, 2 M ammonium hydroxide, 2 M ammonium chloride; curve 2: 1 m M cadmium, 1 M potassium iodide, 1 M potassium nitrate; curve 3: 1 m M nickel (II), 1 M potassium cyanide, 1 M potassium nitrate; curve 4: 2 m M cadmium, 0.5 M sodium tartrate, 1 M sodium nitrate; curve 5, 1 m M cadmium, 0.1 M dipyridyl, 1 M potassium nitrate. Area of dropping mercury electrode: approximately 0.02 cm.².

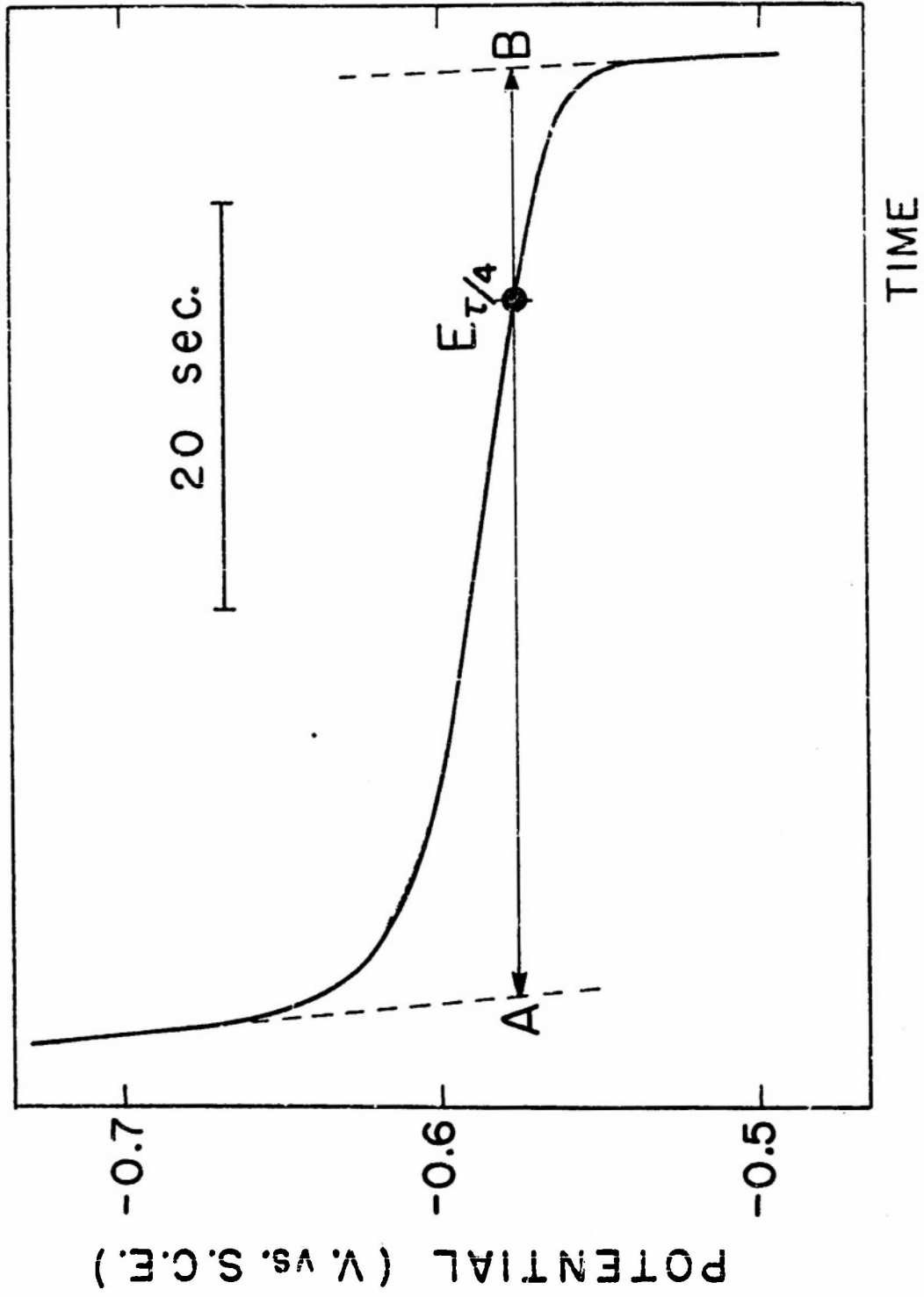

FIG. I

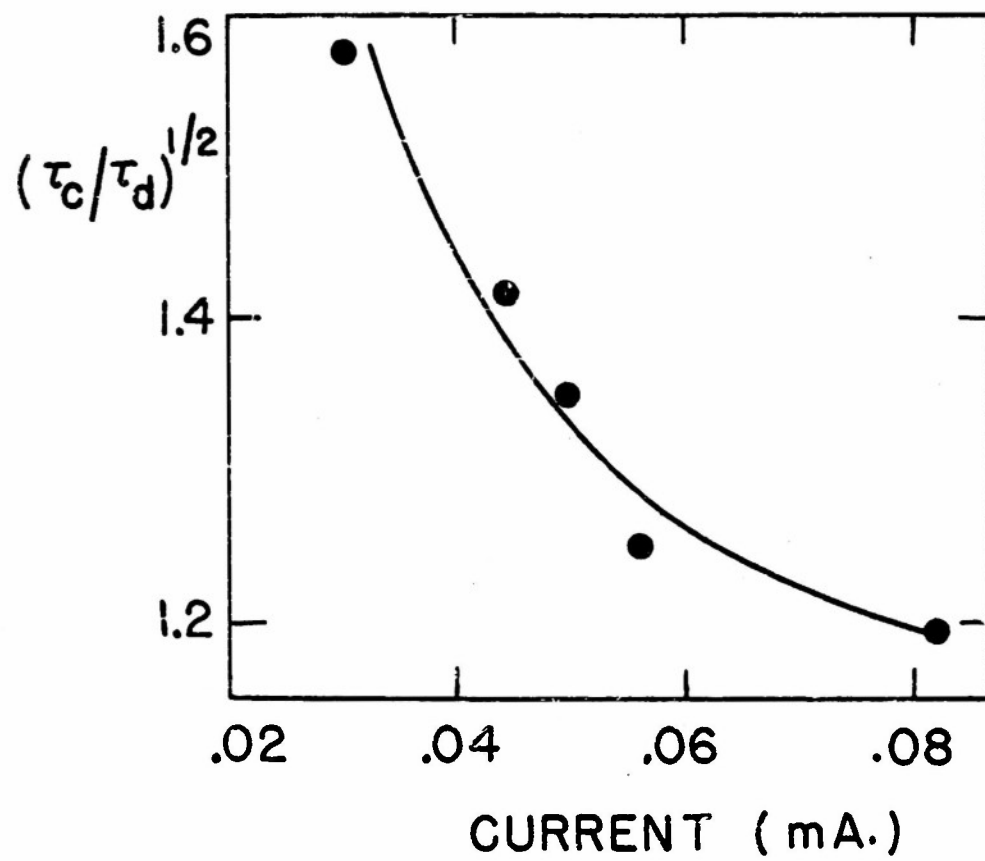

FIG. 2

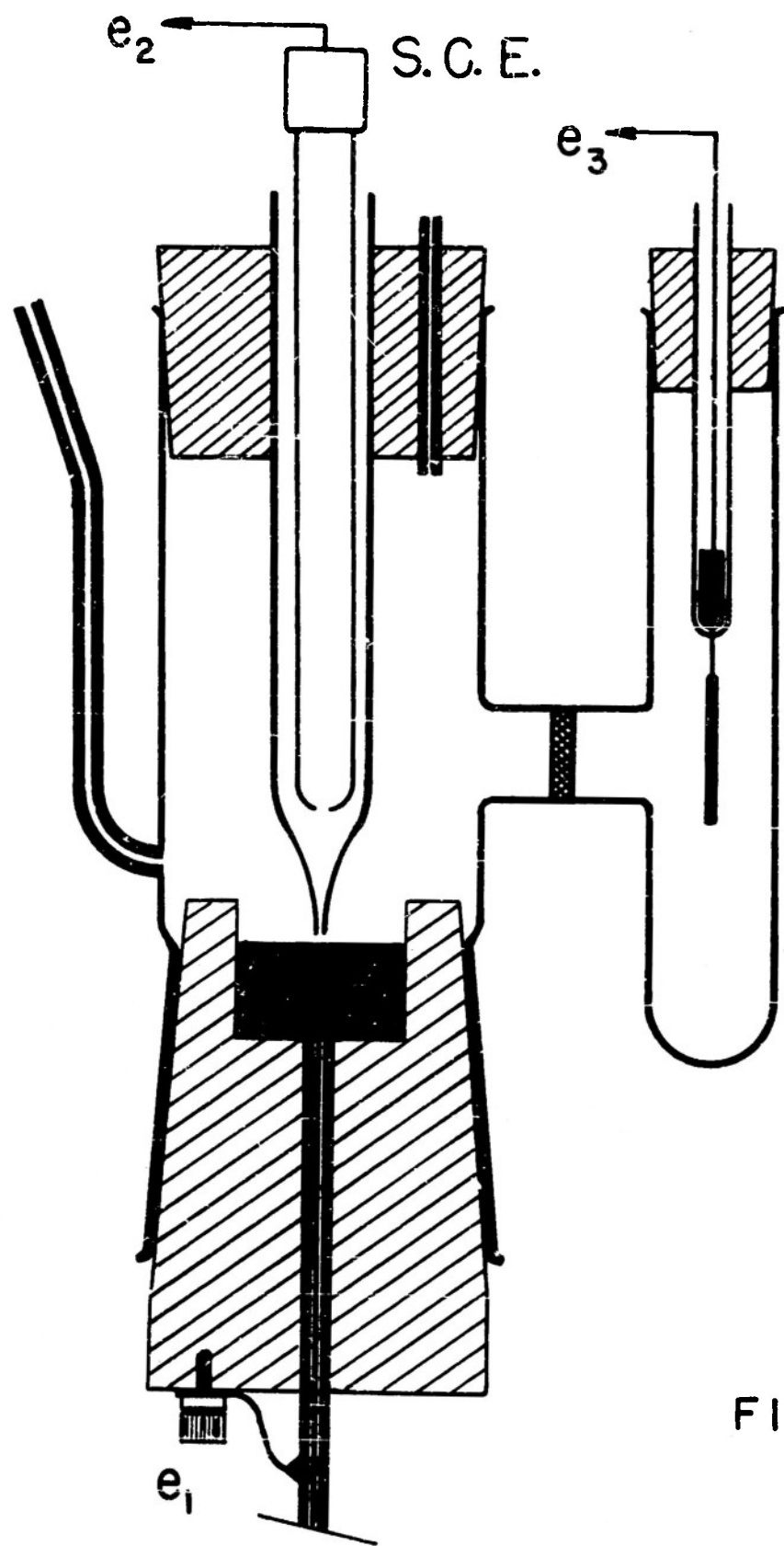

FIG. 3

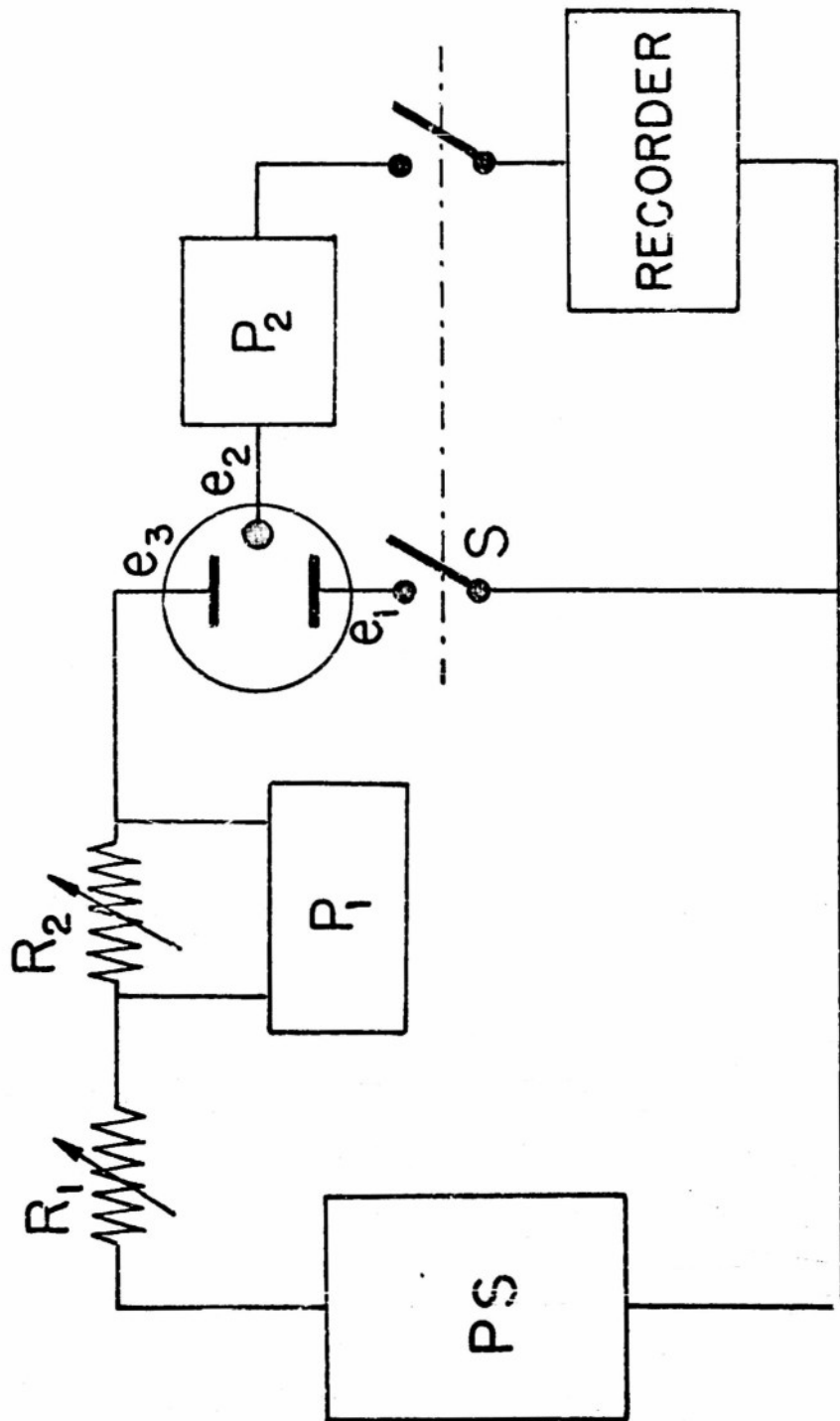

FIG. 4

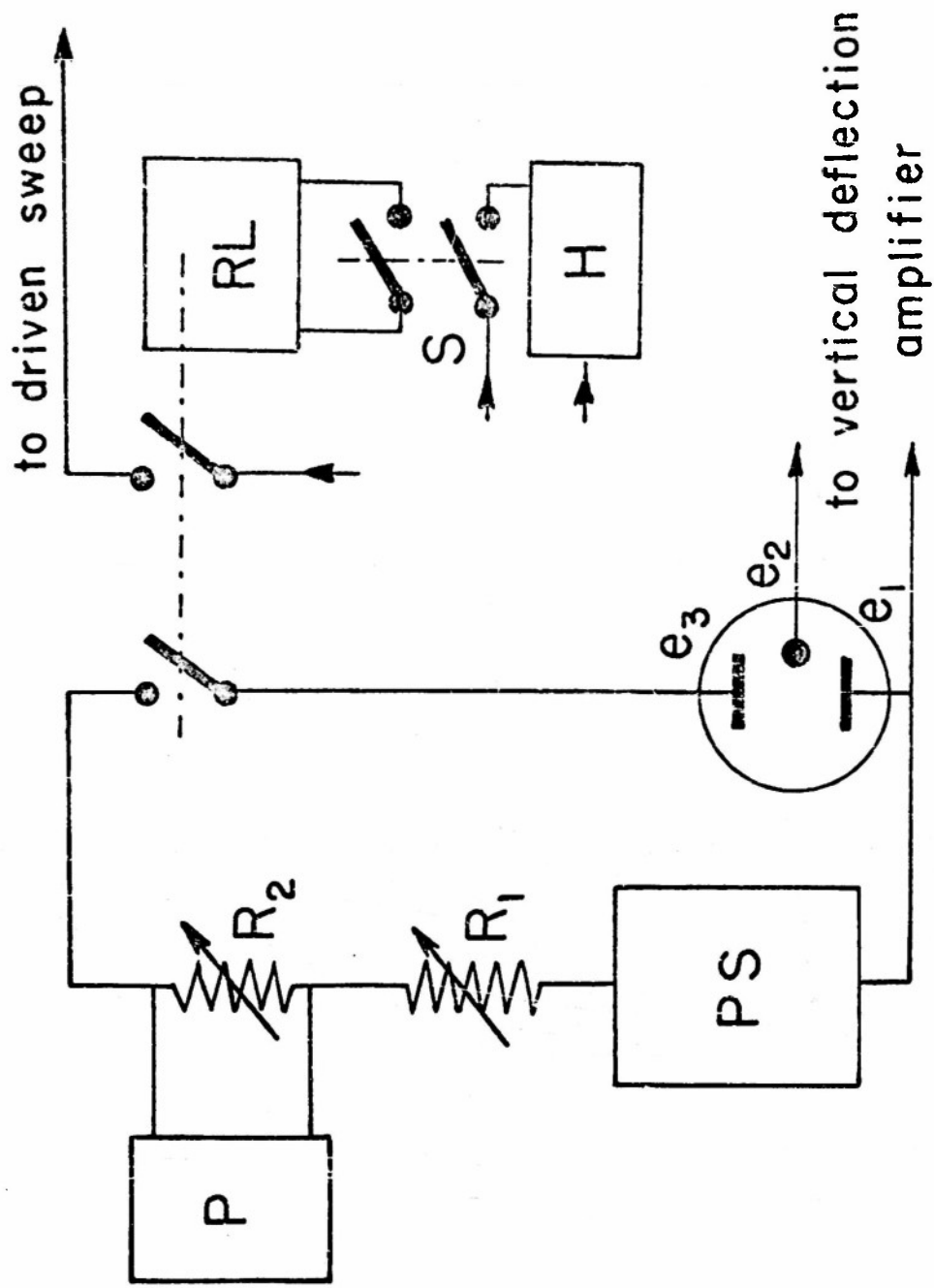

FIG. 5

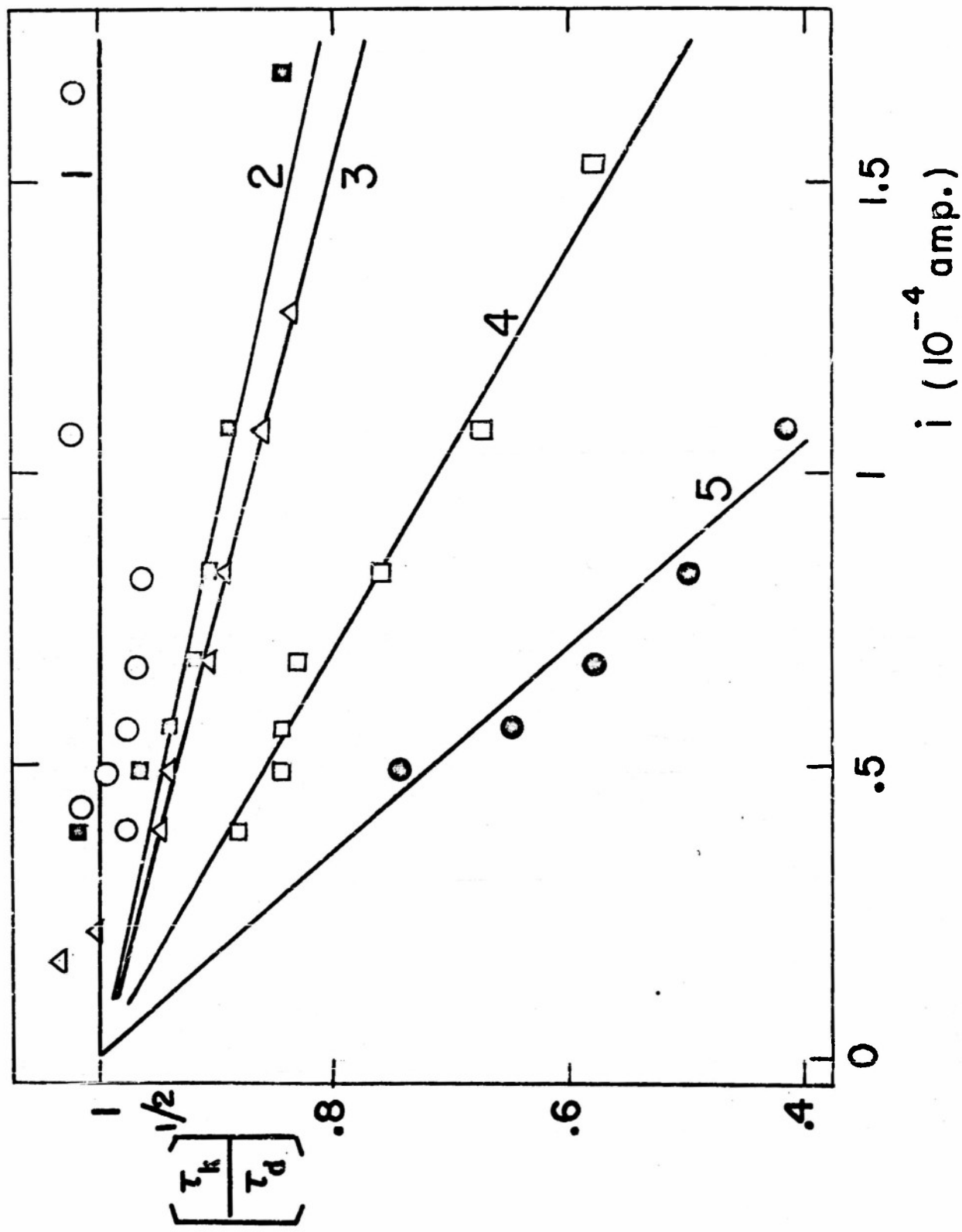

FIG. 6