

AD No. 27661

ASTIA FILE COPY

GENERAL ENGINEERING LABORATORY

DIELECTRIC MATERIALS IONIZATION STUDY

by

W. T. Starr

Data Folder No. DF53GL44-4

January 6, 1954



NAVY DEPARTMENT
OFFICE OF THE INSPECTOR OF MACHINERY, U.S. NAVY
AND
NAVAL INSPECTOR OF ORDNANCE
SCHENECTADY 1, NEW YORK

44A:pe
NObar 57408

4 FEB 1954

From: Inspector of Machinery, USN
To: Bureau of Ships, Code 817

Subj: Contract NObar-57408, General Electric Co., Contractor; Index
No. NE-111273 - Subtask 3, Dielectric Materials Ionization Study;
Interim Engineering Report, forwarding of

Ref: (a) BuShips ltr NObar-57408(817) over Ser 317Y-2001 of 3 Dec
1953

Encl: (1) Nine (9) copies of G.E. Co. Interim Engineering Report

1. Enclosure (1) is forwarded in compliance with the terms of the subject
contract and in accordance with reference (a).

R. BURNETT

D. C. AY
By direction

Copy to:

CG, WADG, WPAFB, Ohio

VIA: BAR(2)(w/1 cy rpt)

Addressee (2)(w/9 cys rpt)

CO, Squier Lab., Signal Corps

Fort Monmouth, N.J. VIA: Navy Liaison Office(2)(w/1 cy rpt)

Dir., NRL, Wash., D.C. (1)(w/1 cy rpt)

Ch., ONR, Elec. Br., Wash., D.C. (1)(w/1 cy rpt)

ChBuAer, Code EL412 (1)(w/1 cy rpt)

ChBuOrd (Rec 1)(1)(w/1 cy rpt)

NOL, White Oaks, Md., Code TE-1(1)(w/1 cy rpt)

NBS, Wash., D.C. (1)(w/1 cy rpt)

GBR, NYK NavShipyd, Brklyn(1)(w/1 cy rpt)

CO, NCF, Ind., Indiana (1)(w/1 cy rpt)

BuStandards Lab., Corona, Calif. (1)(w/2 cys rpt)

INTERIM DEVELOPMENT REPORT #4

FOR

DIELECTRIC MATERIALS IONIZATION STUDY

This report covers the period August 1, 1953 to October 31, 1953

General Electric Company
General Engineering Laboratory
Schenectady, New York

NAVY DEPARTMENT BUREAU OF SHIPS ELECTRONICS DIVISIONS

NOBSR 57408, Index No. NE 111273, Subtask 3

NOT CLASSIFIED

- (1) 9 copies to: Chief, Bureau of Ships
Department of the Navy
Washington 25, D. C.
Attention - Code 817
- (2) 1 copy to: Commanding General
Wright Air Development Center
Wright-Patterson Air Force Base
Ohio
Via: Bureau of Aeronautics Representative
- (3) 1 copy to: Commanding Officer
Squier Laboratory, Signal Corps
Engineering Laboratories
Material Section
C & N Branch
Fort Monmouth, New Jersey
Via: Navy Liaison Office
- (4) 1 copy to: The Director
Naval Research Laboratory
Washington 25, D. C.
Attn: Mr. T. D. Callinan, Code 3306
- (5) 1 copy to: Chief, Office of Naval Research
Electronics Branch
Washington, D. C.
Attn: Code 427, 6411
- (6) 1 copy to: Chief, Bureau of Aeronautics
Department of The Navy
Washington 25, D. C.
Attn: EL412
- (7) 1 copy to: Chief, Bureau of Ordnance
Department of The Navy
Washington 25, D. C.
Attn: Rec 1
- (8) 1 copy to: Naval Ordnance Laboratory
White Oaks, Maryland
Attn: Mr. J. A. Aukward, Code TE-M
- (9) 1 copy to: National Bureau of Standards
Connecticut Avenue
Washington 25, D. C.
Attn: Mr. P. J. Franklin

- (10) 1 copy to: Commander
New York Naval Shipyard
Material Laboratory
Naval Base
Brooklyn 1, New York
Attn: Electricity Branch
- (11) 1 copy to: Commanding Officer
Naval Ordnance Plant
21st & Arlington Avenue
Indianapolis 18, Indiana
Attn: Mr. W. A. Key
- (12) 2 copies to: Bureau of Standards Laboratory
Corona, California
Attn: Section 70.03
- (13) 1 copy to: Mr. R. B. Robinson
U. S. Navy Inspectors Office
G. E. Company, Schenectady
- (14) 1 copy to: Mr. C. L. Eigelback
Marine Engineer
Schenectady, New York

TABLE OF CONTENTS

	<u>Page</u>
Conclusions	1
I. INTRODUCTION	3
II. EFFECT OF MATERIAL PROPERTIES ON SURFACE CORONA	3
A. Corona Starting Voltage	3
1. Dielectric Constant and Thickness	3
2. Surface Hygroscopicity	7
3. Volume Moisture Absorption	10
B. Corona Intensity	10
1. Background and Interpretation	10
2. Dielectric Constant and Thickness	10
3. Surface Hygroscopicity	11
4. Volume Moisture Absorption	12
III. EFFECT OF ELECTRODE SHAPE ON SURFACE CORONA	12
A. Corona Starting Voltage	12
B. Corona Intensity	13
IV. EFFECT OF SAMPLE VOIDS ON CORONA	13
V. EFFECT OF MATERIAL PROPERTIES ON FLASHOVER	17
A. Dielectric Constant and Thickness	17
B. Surface Hygroscopicity	17
VI. ANALYSIS OF CORONA AGING OF TEFLON	19
VII. MATERIALS	23
1. Muscovite Mica	23
2. Pyrex Glass	27
3. Cellulose Acetate	29
4. CR-39 Homalite	31
5. Teflon Glass Laminate	33
6. Polyethylene	35
7. Nylon FM3003	37
8. Commercial Grey Vulcanized Fibre (Grade 2 1/2)	39
VIII. APPENDIX	
A. Ionization Pulse Waveshape	41

TABLE OF CONTENTS

	<u>Page</u>
B. Calibration Procedure for Ionization Testing	43
C. Corona Intensity In Internal Voids	43

CONCLUSIONS

A. Surface Corona - Humidity Characteristics

At low humidities corona intensities climb with increasing voltage much faster than at high humidities at voltages not far removed from the corona starting voltage. This is especially true for materials which show a rapid decrease in surface resistance with increasing humidity. This is due to the fact that at high humidities a good part of the dielectric charging current can be carried by the moisture film.

An exception to the above rule is found in Hard Fibre. For this material, very high losses develop at high humidity which cause the corona starting voltage to drop markedly and the corona intensity to climb much more precipitously with increasing voltage than at low humidities.

The development of a low voltage breakdown condition with hard fibre is believed to be due to the marked increase in the loss factor of the sample at high humidity. Space charge conditions which normally are active in preventing the penetration of the corona discharge energy into the dielectric become inactive and the corona energy heats the dielectric until failure occurs.

B. The corona starting voltage for surface corona can be calculated using an equation describing the voltage stresses in voids at the electrode edge as a function of their depth and comparing the result with an experimental curve of the corona starting voltage of air voids in series with a dielectric. This experimental curve can be expressed very closely by the equation

$$E_{\text{csv}} = 53.9 \sqrt{1 + \frac{24}{t}} \quad \text{Volts per mil}$$

where t is the void depth in mils.

C. The same type of calculation as is indicated in B can be used to determine the effect of electrode radius on the CSV. This calculation shows that when the ratio of dielectric thickness to its dielectric constant is small the electrode radius has only a small effect, whereas when the ratio exceeds a value of 20 (thickness in mils) the effect of radius is critical in determining the CSV.

D. When the ratio of thickness to dielectric constant is small -- under 10 with T expressed in mils -- large increases in corona starting voltage can be obtained by completely filling the very small voids less than 6 mils deep. With large values of T/K (above 20) complete filling of much larger voids is required to effect increases in the CSV.

E. Breakdowns of Teflon on overvoltage aging are almost completely edge breakdowns and the critical voltage for a 100 mil sample is 6 kilovolts. This corresponds almost exactly to the calculated corona starting voltage. The combined effect of the porous nature of the sample and the high value of T/K , however, result in a lower CSV than that calculated.

When surface voids (next to the electrode) exist, breakdowns occur at 5 and 5.5 kilovolts and always occur within the void.

F. Surface Corona - Flashover

1. Flashover voltages are only slightly reduced by conditioning at high humidity.

2. Flashover occurs when the corona intensity reaches a value in the range of 40,000 to 80,000 micro micro coulombs for the samples tested. The corona intensity at flashover is a characteristic of the flashover path length and sample configuration and refers to a 3" x 3" square specimen.

3. The flashover voltage is a function of the ratio of the dielectric thickness to its dielectric constant. When T is expressed in mils this function is approximately given by the equation

$$V_{fo} = 4.09 \sqrt{\frac{T}{K}} + 6.8 \text{ kilovolts rms}$$

for the 3" x 3" specimens used.

G. Corona Intensity in Internal Voids

Corona intensities in internal dielectric voids are given by multiplying the apparent intensity by a factor

$$\frac{T - t}{T + t (K-1)}$$

where T and t are the dielectric and void thickness respectively and K is the sample dielectric constant.

I. INTRODUCTION

This report includes the effects of humidity upon the surface corona characteristics of materials as received. The first part of this report will cover our interpretations of the data in general, including those features which are common to all the materials tested. The second part will describe those features of the data showing singular characteristics of each material. An appendix written by Dr. D. S. Rodbell will cover the use of advanced circuitry for the study of those characteristics of corona transients which, we believe, will lead to a clearer understanding of the mechanisms of corona degradation.

II. EFFECT OF MATERIAL PROPERTIES ON SURFACE CORONA

A. Corona Starting Voltage

1. Dielectric Constant and Thickness

The surface corona starting voltages of the sample materials will depend upon the voltages across the air gaps in the test structure as well as the material itself. In order to study the results obtained and draw conclusions from them, we made a mathematical study of the voltage distributions as affected by the material thickness, dielectric constant, and electrode geometry. The method is partly mathematical and partly graphical. Two assumptions were made. The first was that the electrode could be represented with fair accuracy by the shape and size indicated in Figure 1. The second assumption was that the electric field in the region where corona starts is essentially uniform. The reasonableness of the assumptions is borne out by the accuracy with which a corona starting voltage may be calculated.

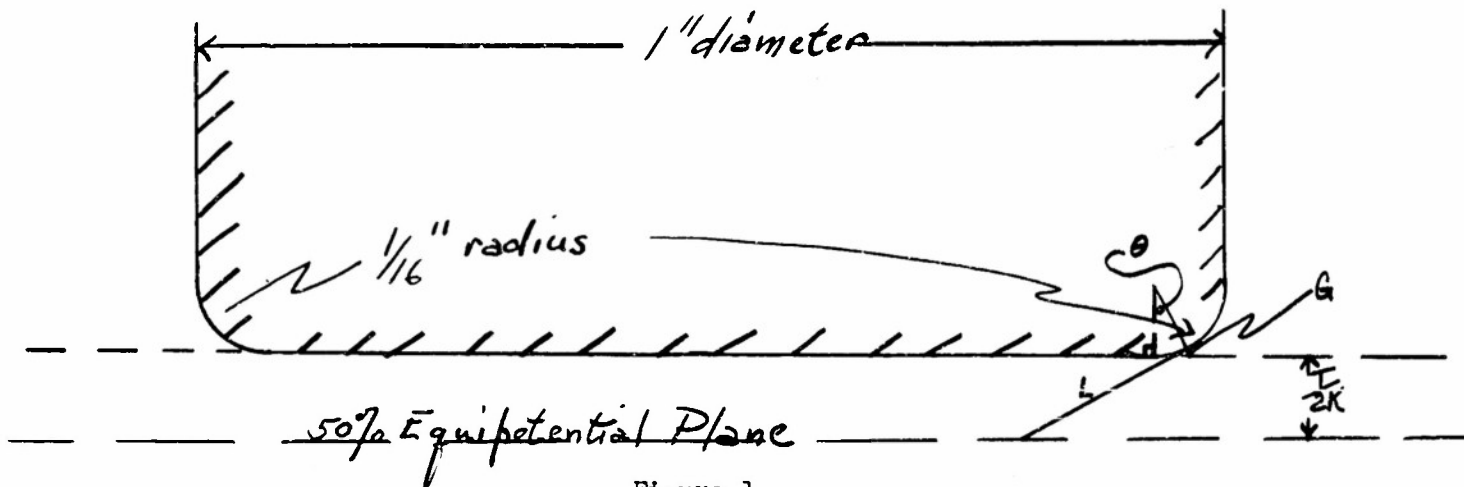

Figure 1

If the field is uniform as assumed, the dielectric can be replaced by an equivalent thickness of air. This equivalent thickness will be given by the ratio of the material thickness to its dielectric constant (T/K).

Now with this substitution, the positions of the flux lines and equipotential lines can be calculated. The equations used are as follows.

$$E \text{ (average)} = 28.65 \frac{V}{L\theta} \text{ volts per mil}$$

$$L = \frac{1 - \cos \theta}{16 \sin \theta} + \frac{T}{2 K \sin \theta}$$

$$G = .1743 L \left(\theta - \sin^{-1} \frac{T}{2KL} \right) \text{ inches}$$

$$E \text{ (maximum)} = \frac{2 E_{avg} (2K + 8T)}{3 K + 8T + K \cos \theta} \text{ volts per mil}$$

Where E_{max} is the maximum volts per mil in the air gap section considered.

E_{avg} is the average volts per mil in the air gap considered.

θ determines the air gap region considered and is shown in Figure 1.

L is the length in inches of the subtangent to the 50% equipotential plane and is shown in Figure 1.

G is the depth in inches of the air gap considered. This air gap is the distance along a flux line from the electrode to the surface of the dielectric. This is shown in Figure 1.

V is the voltage applied between electrodes in kilovolts.

A value of V is assumed which is within 50% of the corona starting voltage. Then, using these equations and values of θ ranging from 5° to 45° in 5° intervals, the values of $E_{maximum}$ and G for each value of θ were obtained. Next, a plot is made of $E_{maximum}$ vs G . On the same graph paper a plot is made of corona starting voltage stress vs G . This is a standard curve determined in this laboratory. These two plots are shown as curves 1 and 2 of Figure 2. From these curves, it is apparent that the voltage stress across none of the gaps in Curve 1 is sufficient for corona formation. Since V and E_{max} are strictly proportional, a correction can be applied to V which will increase the ordinate values of all points on Curve 1 by a constant factor. When this correction is just enough to make the curves touch in one point, the value of V is the corona starting voltage. This condition is illustrated by the curve for Teflon at 5650 volts as given in Figure 3.

This technique has advantages besides facilitating an analysis of the data. It shows the size of the air gaps in which corona first occurs. When the insulation is very thin so that the ratio T/K (with T expressed in mils) lies in the range of 0 to 5, the first corona is found to occur in very small gaps in the range of 0 - 2.5 mils depth and the voltage required for ionization of larger gaps increases rapidly with gap size. An impregnation technique can thus be chosen which fills the smaller gaps thoroughly and results in large increases in the corona starting voltage. When, however, the range of T/K lies

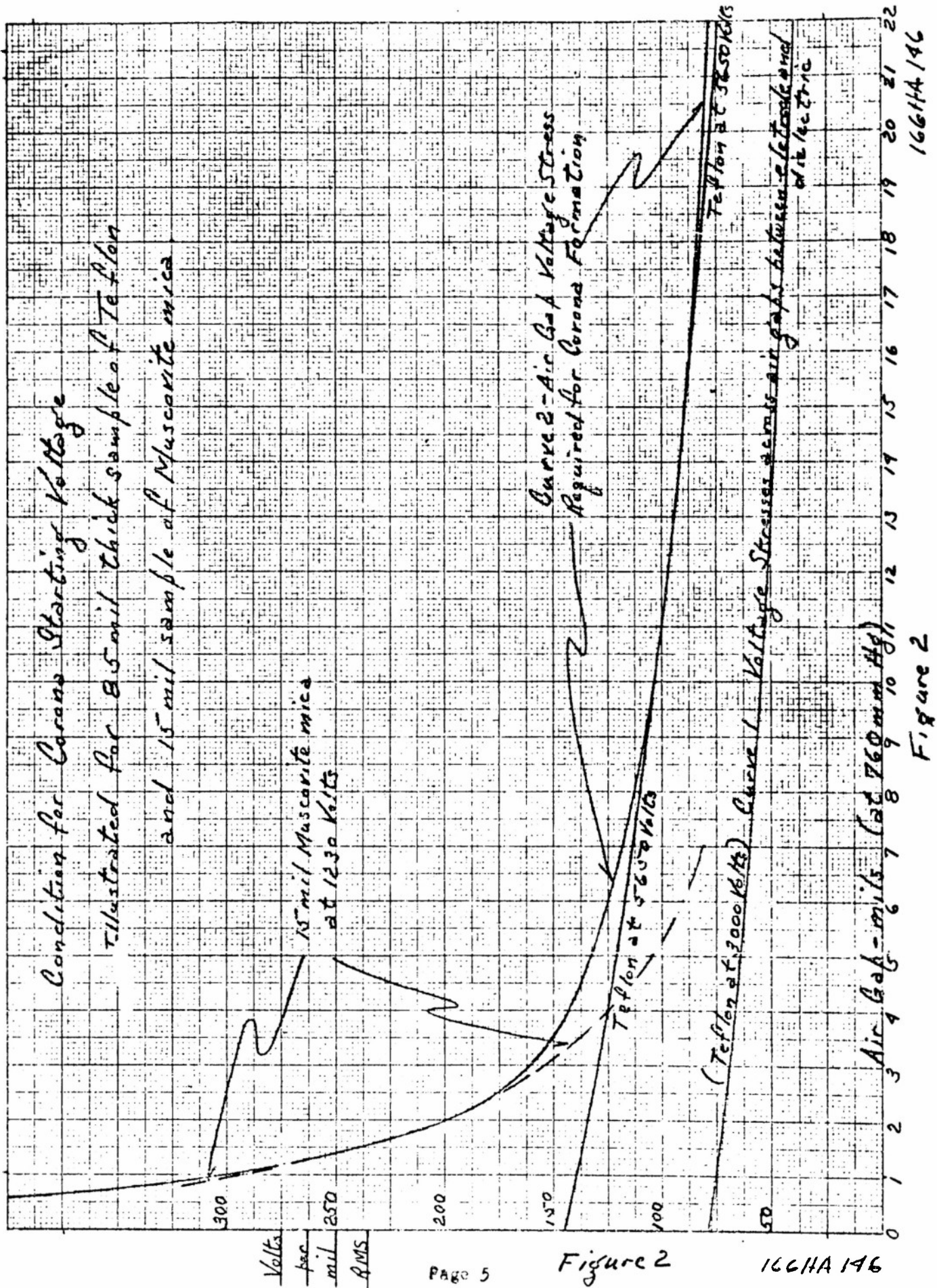

Figure 2

Figure 2

above 10, the gaps which ionize first are much larger and the corona starting voltage does not increase rapidly with increasing gap depth. Thus, any impregnation technique must completely fill all voids to effect an increase in corona starting voltage. As an illustration of this, Figure 2 shows a comparison of the condition for corona starting voltage for 15 mil Muscovite mica compared to 85 mil Teflon. Table 1 summarizes the results of this analysis in terms of corona starting voltage, corona starting voltage stress, ionizing gap and the effects of filling the smaller gaps on the corona starting stress for some representative dielectric samples.

TABLE 1

T/K	.75	1.50	2.25	3.0	8.96	42.2
Material	← Muscovite	Mica			→ Pyrex	Teflon
Thickness - mils	5	10	15	20	43	87
Corona Starting Voltage	860	960	1230	1370	2270	5700
Corona Starting Voltage Stress Rms volts/mil	172	96	83	68.5	53	65.5
Corona Starting Gap (mils)	1	1	1.52	2	3	12-20
Corona Starting Stress at 10 mils Gap	420	210	140	105	65.1	67
Experimental CSV	See Figure 11				43	45

The last item in the table, that is, the corona starting stress at 10 mils gap spacing, indicates the corona starting stress (based on the dielectric thickness) which would hold if the volume between the electrode and the dielectric surface were filled with a resin so that no gaps smaller than 10 mils existed. This is illustrated in the following sketch.

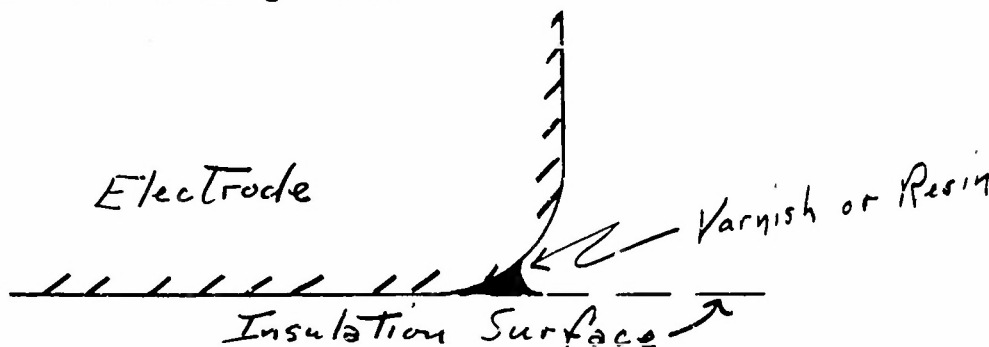

Figure 3

Three curves are plotted on Figure 4 which illustrate the variation of calculated CSV with the ratio T/K for electrodes with 1/32", 1/16" and 1/8" radii on the edge. The electrode used in this work is nominally 1/16" radius, but the actual radius is not accurately machined so that it is represented more closely by the 1/32" radius curve. The effect of electrode radius is treated in more detail in Section B. The corona starting voltages of all the materials tested are also plotted on Figure 4. Several facts come to light upon studying this data.

- (1) Polar materials (with the exception of Nylon) have lower than ideal corona starting voltages.
- (2) Non-polar materials have close to ideal corona starting voltages.
- (3) At low values of T/K there is a larger percentage difference between the voltage at which "faint" corona (between 20 and 200 $\mu\mu$ Coulombs) appears and the voltage at which intense corona (above 500 $\mu\mu$ Coulombs) appears than at large values of T/K. This is to be expected since at low values of T/K corona starts in small gaps while at high values of T/K it occurs first in large gaps.

2. Surface Hygroscopicity

With essentially clean surfaces on the dielectric, the corona starting voltage is changed by the grading effects of the surface moisture films. At this time, no analysis of this effect is presented because data upon the surface resistivity changes with humidity is not available. An overall conclusion that may be drawn is that the CSV is lowered on moisture sensitive materials as the surface resistivity drops with increasing humidity, but is increased markedly when the surface resistivity drops below some critical value. Some materials traverse this range over a much smaller ambient humidity range than others. The following statements may be made concerning the CSV test results obtained at 0, 25, 50, 75, 90, and 100% RH at 25°C.

a. The CSV's for the following materials are not effected by ambient humidities up to 100%.

- (1) Teflon
- (2) Teflon-Glass Laminate
- (3) CR-39 Homalite

b. Pyrex Glass - The CSV drops from 45 to 40 volts per mil from 50 to 75% RH, and then increases to 70 volts per mil at 100% RH.

c. Cellulose Acetate - The CSV drops from 39 volts per mil at 0% RH to 22 volts per mil at 50, 75, 90 and 100% RH.

d. Commercial Grey Vulcanized Fibre Grade 2 1/2 - The CSV drops from 28 volts per mil at 0% RH to 20 volts per mil at 50% RH, to 12 volts per mil at 75% RH, to 10 volts per mil at 90 and 100% RH. This marked drop is due to

Comparison of Experimental with Calculated Corona Starting Voltages

Starting Voltages

Solid lines represent calculated corona starting voltages for electrodes of $\frac{1}{32}$ " and $\frac{1}{16}$ " radius

Blocked in legend characters indicate intense corona

Open characters indicate faint corona

Corona Starting Voltage

1000

2000

3000

4000

5000

6000

- Polyethylene
- x Muscovite Mica
- ⊙ Teflon
- Cellulose Acetate
- Pyrex
- △ Teflon Glass
- CR-39
- Unplasticized PVC
- Nylon
- Hard Fibre
- Baryl Rubber
- △ Plasticized PVC

$\frac{1}{8}$ " radius

$\frac{1}{16}$ " radius

$\frac{1}{32}$ " radius

W. T. Stark
General Engineering Laboratory
Dec. 15, 1953

Dielectric Thickness (mils)
Dielectric Constant

Figure 1

16CHA197

16CHA197

Figure 1

large changes in volume losses as well as surface changes.

e. Muscovite Mica - The CSV is stable in the range of 0% to 90% RH. At 100%, the CSV is four times the CSV at lower humidities.

f. Unplasticized Polyvinyl Chloride Bolatron 6200 A

<u>% RH</u>	<u>CSV per mil (avg.)</u>	<u>% of 50% RH CSV per mil</u>
0	45.	103
50	43.5	100
75	35	80
90	32 & 65	74 & 150
100	-----	-----

The change in CSV with RH is normal up to 90% RH. It is interesting to note that when corona first occurred on the sample with the marked increase in CSV at 90% RH, the corona intensity immediately reached a value of 47000 μC Coulombs. This is dangerously close to the corona intensity characteristic of flashover for these 3" x 3" samples and flashover would probably have occurred with a smaller creepage distance. This is the only material tested thus far which showed this effect.

g. Nylon FM 3003

<u>% RH</u>	<u>CSV per mil (avg.)</u>	<u>% of 50% RH CSV/mil</u>
0	40	108
50	37	100
75	29	78
90	25	68
100	25	68

The corona starting stress for Nylon varies as shown above with changing ambient humidity.

h. Plasticized Polyvinyl Chloride

<u>% RH</u>	<u>CSV/mil (avg.)</u>	<u>% of 50% RH CSV/mil</u>
0	24	80%
50	30	100%
75	22	73%
-----	-----	-----
-----	-----	-----

i. Polyethylene

<u>% RH</u>	<u>CSV/mil (avg.)</u>	<u>% of 50% RH CSV/mil</u>
0	50	100
50	50	100
75	40	80
90	37	74
100	37	74

It was surprising to note that the CSV of polyethylene was changed by ambient humidity. It may be that the presence of moisture increases the effectiveness of impurities in concentrating the stress.

3. Volume Moisture Absorption

In only one case can it be definitely stated that the change in the CSV is due to volume moisture absorption rather than to a surface effect. The material in this case is Hard Fibre. More materials would undoubtedly be placed in this class if the data on the variation of dielectric constant with ambient humidity were available. For a full treatment of Hard Fibre behavior see the section on Materials.

B. Corona Intensity

1. Background and Interpretation

It has been our practice in this laboratory to obtain a corona intensity vs voltage plot for an apparatus to determine the maximum voltage which can safely be applied to the apparatus. This plot is then a fingerprint of the system whereby any alteration to the insulation system can quickly be compared and assessed. Under this contract we are using this same fingerprint system to compare insulation materials in the belief that it can help us determine the factors responsible for insulation breakdown.

The insulations are being compared under various conditions of ambient temperature, humidity, voltage stress and frequency. These conditions cover a wide range of possible uses, but certainly not all. For the purposes of the contract, it has been necessary to select an insulation thickness and electrode system for test. The corona intensity vs voltage plots obtained reflect this selection as much as any other variable. The overall objective of this contract is to obtain comparisons between the behaviors of materials under corona conditions. In order to make such comparisons, we must first know the conditions themselves. This is done by studying the corona intensity vs voltage plots of each material. During aging, the changes in this plot will be studied. The data thus obtained will be analyzed to determine the conditions resulting in failure.

2. Dielectric Constant and Thickness

It has been mentioned in connection with the study of the results shown on Figure 2 that, at low values of the ratio of thickness to dielectric constant, relatively low intensity corona precedes voltage wise the inception of intense corona. This has been explained as being due to the fact that for low values of T/K, corona inception conditions are first reached in very small voids whereas for large values of T/K the conditions for corona are first met in relatively large voids.

It will be mentioned in the Materials section that the intensity of corona observed on Muscovite Mica at voltages above two or three times corona starting voltage is a function of applied voltage and not of T/K. This is true at small values of T/K, but is not so for large values. When T/K exceeds 20, the rate of increase of corona intensity with increasing voltage falls off. Thus for Muscovite Mica, the intensity at CSV + 5000 volts is 10,000 $\mu\mu$ Coulombs whereas for polyethylene, the corresponding value is 5000 $\mu\mu$ Coulombs. This is not a very significant difference.

3. Surface Hygroscopicity

The relative humidity has more effect upon the rate of increase of corona intensity with increasing voltage than any other factor tested. At 0% RH (over Drierite) most materials tested exhibited larger corona intensities at voltages only slightly above corona starting voltage than at higher humidity ambients. The effect is not noted on materials which have small surface water absorption such as polyethylene, teflon, and teflon glass laminate. The effect is noted on materials which tend to adsorb water on their surfaces such as Muscovite Mica, Pyrex, Cellulose Acetate, CR-39 Homalite, Hard Fibre, Nylon, Plasticized Polyvinyl Chloride and Unplasticized Polyvinyl Chloride. It is probable that this effect follows an expected behavior: at lower humidities for any given voltage, fewer discharge avalanches will develop. Therefore, when one does form, it may have the energy of the two or three which would form at higher humidity. This premise is given substance by the apparent drop in corona intensity with increasing voltage which is noted on some of these materials. As more and more avalanches form with increasing voltage, the residual ionization products make succeeding ionization easier and decrease the gap overvoltage at which ionization occurs. If this is true, pulse counting techniques would indicate that the number of corona pulses decreases with decreasing humidity.

In general, corona intensity at any given voltage decreases with increasing humidity. For some materials, the intensity decreases steadily from 0% to 100% RH (c.f. Pyrex Glass and CR-39 Homalite). For others, very little effect is noted until 90 or 100% humidity is reached (c.f. Muscovite Mica, Teflon Glass Laminate (slight effect), Polyethylene (slight effect)). Some materials such as Teflon and Nylon exhibit very little change of corona intensity with ambient humidity.

One material, unplasticized polyvinyl chloride showed an interesting effect at 90% relative humidity. First, a marked increase in corona starting voltage was noted, showing the formation of a continuous moisture film. Corona started sporadically and then developed into continuous corona of very high intensity. This undoubtedly marked the rupture of the surface moisture film. The intensity was practically that required under normal conditions for flashover of the 3" x 3" sample used. At higher voltages, the intensity returned to normal.

This effect is important and will probably be encountered much more frequently when testing corona characteristics of materials after immersion in water.

4. Volume Moisture Absorption

Volume moisture absorption undoubtedly changed the dielectric constant of several of the materials tested and thus had a slight effect on corona intensity. The one material where a significant effect was noted was Hard Fibre. For a complete discussion of this see the Materials section.

III. EFFECT OF ELECTRODE SHAPE ON SURFACE CORONA

A. Corona Starting Voltage

The analytical technique in Section II-A-1 can also be used to determine the effect of the electrode shape upon the corona starting voltage. The equations below are used for this analysis in exactly the same manner as indicated before

$$E = \frac{.1146K (4Kr + T) \sin \theta Va}{\theta (2Kr (1 - \cos \theta) + T) (2Kr (3 + \cos \theta) + T)}$$

$$G = .01743 \left[\frac{2Kr (1 - \cos \theta) + T}{2K \sin \theta} \right] \left[\theta - \sin^{-1} \frac{T}{2KL} \right]$$

$$L = \frac{2Kr (1 - \cos \theta) + T}{2K \sin G}$$

where r is the radius of the electrode edge in inches. The results of this analysis are shown in Table 2. When T/K is small, electrode radius has little effect on the corona starting voltage. When T/K is large, however, the radius of the electrode becomes critical in determining the CSV.

This method of analysis is limited by inherent inaccuracies to ranges where T/K (with T expressed in inches) is equal to or less than "r" in inches.

The data is also plotted on Figure 5. The more plentiful data obtained with the 1/16 inch radius were used to obtain the trend of the curves. Two other curves, Figures 6 and 7, are included to show why the electrode radius is

TABLE 2

Effect of Electrode Edge Radius on Calculated Corona Starting Voltage

T/K (mils/K)	Radius of Electrode Edge		
	1/32	1/16"	1/8"
50	5540	5980	6450
50			
20	3640	3770	3860
10	2380	2470	2540

more critical at larger values of T/K. Figure 6 shows the effect of changing radius when T/K is small (10 mils per unit DK). Here, the corona starting voltage depends upon the stress in a small gap where the three curves lie close together. Therefore, the corona starting voltage is not affected much by changing electrode edge radius. Figure 7 shows the effect of changing radius when T/K is large (50 mils per unit DK). In this case, the CSV depends upon the stress in a large gap where the curves are far apart. In this case, the CSV will be changed rapidly with changes in electrode radius.

B. Corona Intensity

From inspection, the corona intensity may be expected to climb more rapidly during increasing voltage with a small radius electrode than with a larger radius electrode. The change will be hard to observe, however, due to the natural large rate of increase of corona intensity with voltage. Thus, electrode radius should have little effect on corona life of materials.

IV. EFFECT OF SAMPLE VOIDS ON CORONA

The samples of Alsimag #228 - Grade L-4A Steatite were made with prepared voids about 35 mils deep and 1/2 inch in diameter on each surface as shown on Figure 8. This was done in order to provide conditions of concentrated corona attack on a material naturally resistant to corona. As shown on Figure 8, the presence of these voids makes a marked difference in the appearance of the corona intensity vs voltage curve. Very intense corona appears at voltages very close to corona starting voltage and this corona maintains almost unchanged intensity up to breakdown. The breakdowns occur at the outer edges of the void in the same manner as was noted by Mason in his work on polyethylene. This is a significant fact since chemical changes on the surface of the steatite would not be expected in this case to contribute markedly to the breakdown. It is probable that under corona conditions, the voltage stress on the material at the edge of the void is about double that which appears at the center of the void. This will occur if the corona which occurs first at the deepest void section discharges only a part of the insulation surface making a virtual electrode of the center part of the insulation surface and increasing the voltage gradient required for corona at the edge of the void. When the required voltage gradient is reached, however,

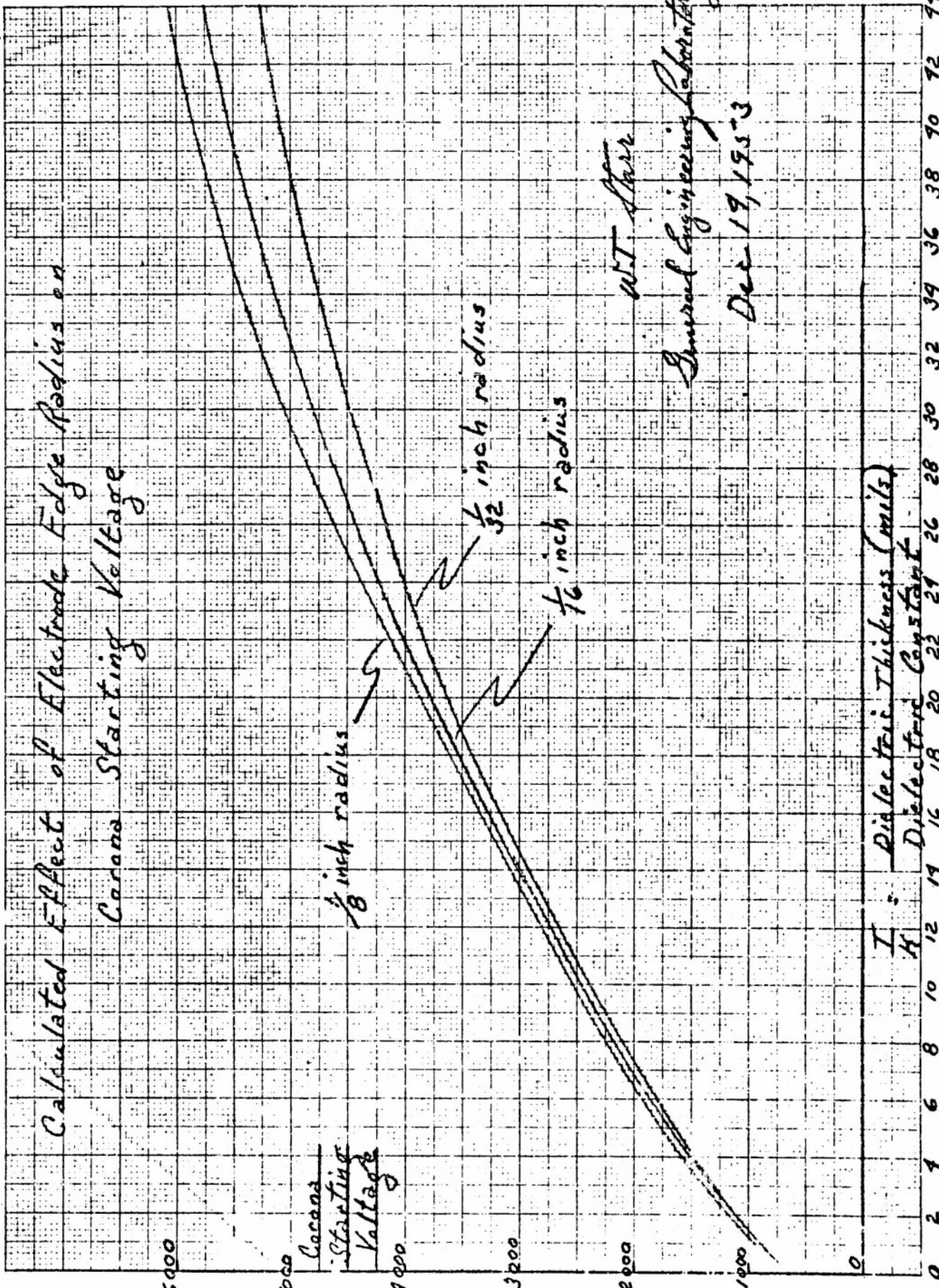

Page 14

Figure 5

166HA148

W.T. Starr

General Engineering Laboratory

Dec 19, 1953

$\frac{T}{H}$: Dielectric Thickness (mils)
Dielectric Constant

166HA148

EFFECT of Electrode Edge Radius on the Voltage Stress
 in the Air Gap of an Electrode Edge

$$TK = 10 \text{ mils/foot D.K.}$$

Corona Starting Voltage Stress

3/2" radius

1/2" radius

1/8" radius

Calculated for an Applied Voltage of 2000V

W.T. Storr

Nov-20, 1953

General Engineering Laboratory

8 1 2 3 4 5 6 7 8 9 10 11 12 13 14 15 16 17 18 19 20

166HA150

Figure 6

166HA150

Effect of Electrode Edge Radius on the Voltage
Stress in the Air Gap at an Electrode Edge

$$TK = 50 \text{ mils/unit Dix}$$

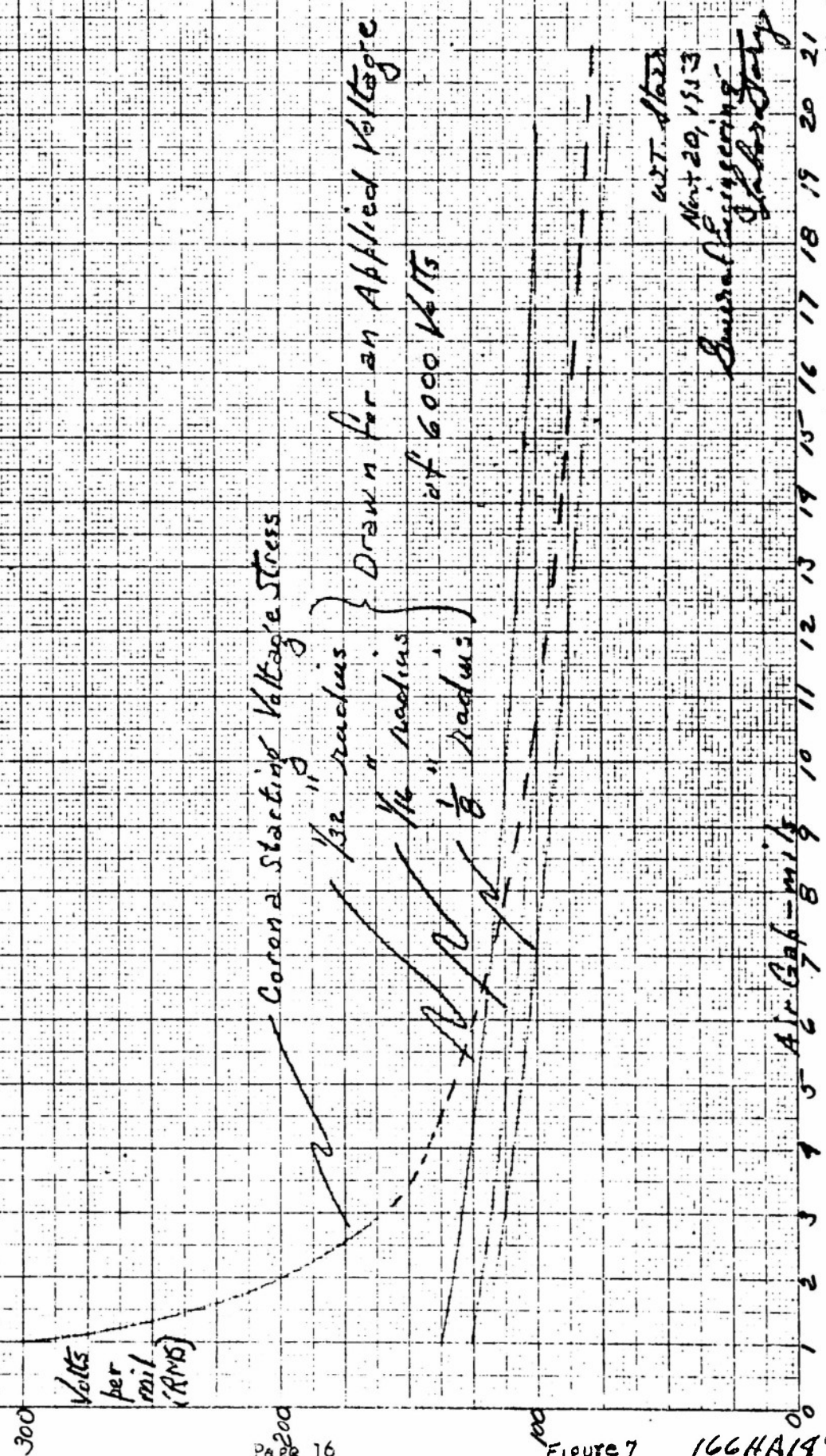

Drawn for an Applied Voltage
of 6000 Volts

W.T. Datta
Nov 20, 1913
General Engineering
Laboratory

166HA199

conditions are right for discharge of both the virtual and the actual electrode into this region and a highly concentrated streamer with many side branches should result. Due to the time lag in the formation of the corona at the void edge, practically the full value of the peak to peak applied can occur at the void edge. The ideas expressed here are tentative and the occurrence of this type of breakdown condition is extremely common. It is hoped that we can accumulate conclusive evidence on this subject with the work under this contract.

The average breakdown stress with the manufactured void is low at 198 volts per mil. The actual breakdown strength should, however, be figured on the thickness of the thin dielectric section, and becomes 455 volts per mil. It is interesting to note that the breakdown strength of the 125 mil section tested under 10 C oil was only 336 volts per mil and occurred when streamers formed in the oil at the electrode edge.

A few test results at 1 Megacycle show that at this frequency breakdowns occur at the center of the void and at the very low voltage of 3000 volts rms, which is only 60 volts per mil figured upon the thin section of the void. The corona starting voltage at one megacycle is the same, however, as the sixty cycle value.

The corona starting voltage lies below the curve of Figure 4, but is still within the range of experimental results in its region of T/K ($T/K = 21.2$, CSV = 2880V) so that it is not possible to determine whether the first corona observed is within the void or at the electrode edge.

V. EFFECT OF MATERIAL PROPERTIES ON FLASHOVER

A. Dielectric Constant and Thickness

The flashover voltages of the 3" square specimens have been found to be a function of the ratio of the thickness to the dielectric constant of the material. This function is plotted in Figure 9. For comparison, a curve drawn to the function

$$V_{f.o.}^{-6.8} = 4.09 (T/K)^{1/2}$$

is shown on the same sheet. Our interpretation of this behavior is that the corona avalanche traveling along the insulation surface away from one electrode induces an avalanche on the opposite surface which travels toward the other electrode. The efficiency of this induction process will determine the area of the insulation surface discharged by one corona streamer and will increase with decreasing values of the T/K ratio. When the area charged by corona approaches, the area of the sample flashover occurs.

B. Surface Hygroscopicity

With our method of test wherein the voltage on the sample is raised slowly to breakdown, ambient humidity has little effect upon the flashover voltage. With surge voltages, however, a much larger effect may exist.

REV NO. 166 HA 151

TITLE Corona Intensity vs 60 cycle voltage stress for Teflon, Unplasticized polyvinyl chloride, and

CONT ON SHEET SH NO.

CONT ON SHEET SH NO.

FIRST MADE FOR Alsimag #228 with a manufactured void
Tests at 75% RH - 25°C.

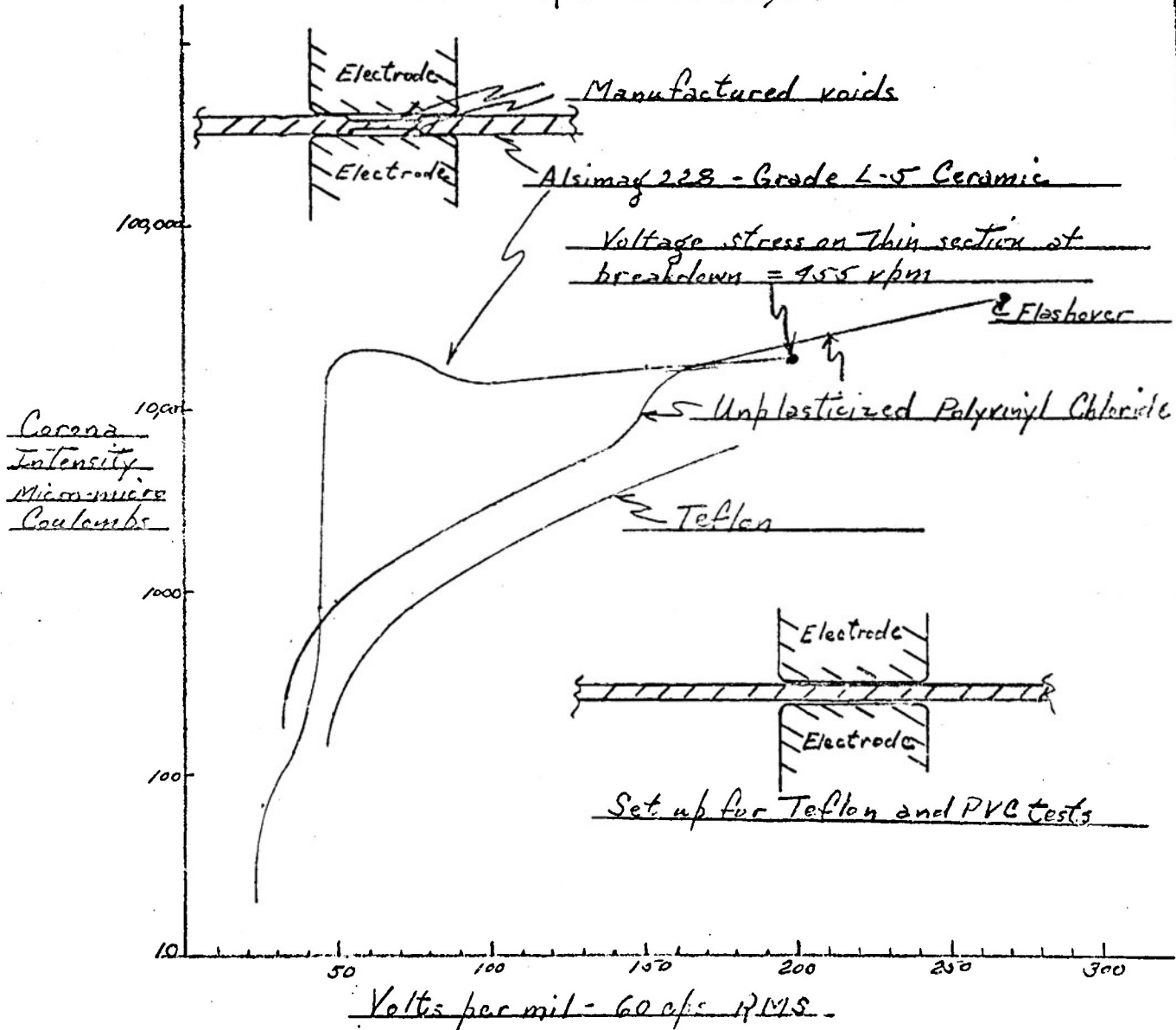

REVISIONS		PRINTS TO	

MADE BY W.T. Stess
ISSUED Nov-10-1953

APPROVALS
John E. ... DIV
Schmuck WORKS

166 HA 151
CONT ON SHEET SH NO.

Table 3 shows the effect of ambient humidity upon the flashover stress for the various materials tested. The reduction of flashover stress with increasing humidity does not seem to be a function of the material.

TABLE 3

Material	Flashover Voltage - Percent of 50% RH Value					
	T/K (mils/K)	<u>Flashover Voltage - 60 cps rms</u>				
		KV at 50% RH	Percent of 50% RH Value			
		0%	75%	90%	100%	
Pyrex	9.4	20	89	90	---	88
Hard Fibre	10.6	19.5	103	BD	BD	BD
Plasticized P. V. C.	10.6	24	94	92	---	---
Cellulose Acetate	16	24.7	102	82	79	83
Nylon	18.6	27.2	88	96	96	79
Butyl Rubber	20.2	24	---	92	90	83
CR-39 Homalite	22.7	27.5	99	89	84	81
Unplasticized P. V. C.	28.6	28.7	97	96	87	---
Teflon-Glass	26	28.2	101	91	85	84
Polyethylene	43.1	30.5	---	89	86	79
Average Change Percent			97	91	87	82

VI. ANALYSIS OF THE CORONA AGING OF TEFLON

A good part of the data for Teflon is condensed on Figure 10. It will be noted that the corona starting voltages are always lower than the calculated value. We believe this is due to the porous nature of the material. The range of breakdown voltage stress values observed during corona aging has for its lower limit the calculated corona starting voltage for external corona. This agrees with the aging data since a large portion of the breakdowns occurred at the edge of the electrode. Breakdown always occurred before flashover during corona test, and in this case, showed little preference for the electrode edge. Ambient humidity had no effect upon the corona intensity vs voltage characteristic even at 100% RH.

The results of the corona aging study of Teflon are shown in Table 4. Samples with centered voids and without voids did not fail in 345 hours at 5.0 kilovolts or 480 hours at 5.5 kilovolts rms. All of these samples failed within 1052 hours at 6.0 kilovolts and all of the breakdowns occurred at the electrode edge.

Surface grooves aggravated the corona condition so that failure always occurred in the groove and at either 5.0 or 5.5 kilovolts.

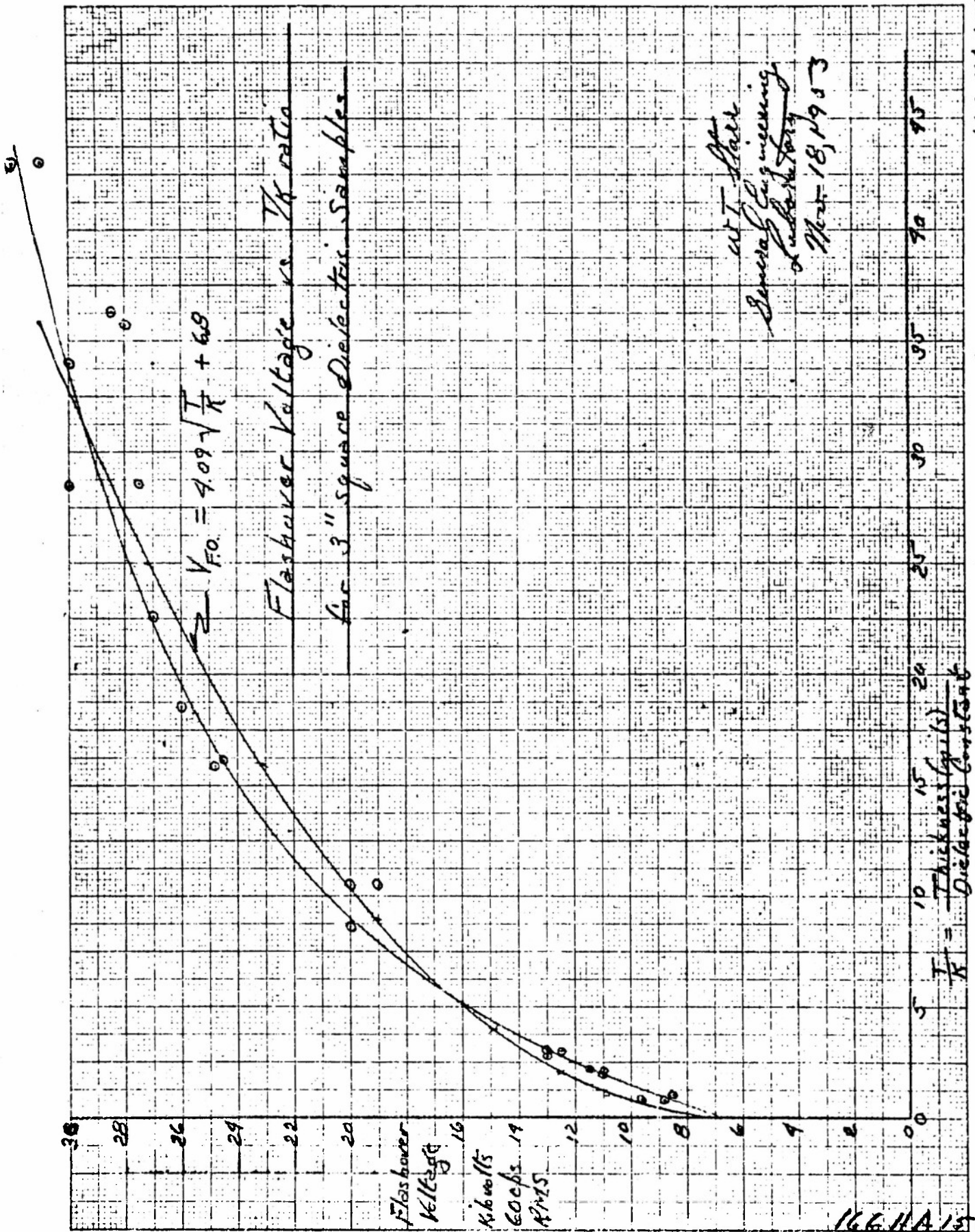

166 HA 152

166 HA 152

TABLE 4

Corona Aging of Teflon

Void Type	Sample No.	5.0 kilovolts rms Hours to Breakdown	Sample No.	5.5 kilovolts rms Hours to Breakdown	Sample No.	6.0 Kilovolts rms Hours to Breakdown
None	1	>345	3	>480	5	89.5
	2	>345	4	>480	6	175
Centered 25 mil dia. hole	1	>345	3	>480	5	447
	2	>345	4	>480	6	164
Off center 25 mil. dia. hole	1	>345	3	>480	5	648
	2	>345	4	>480	6	382
Long surface groove	1	>345	3	>480	5	272
	2	122	4	>480	6	1052
Short surface groove	1	>345	3	359		
	2	216				

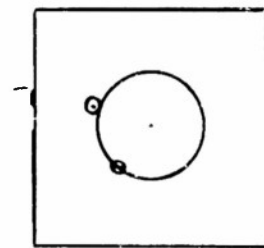

No Void

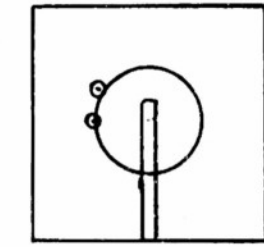

Centered Hole

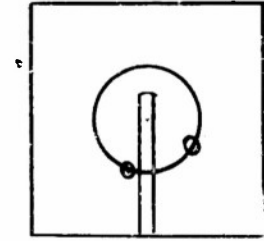

Off Center Hole

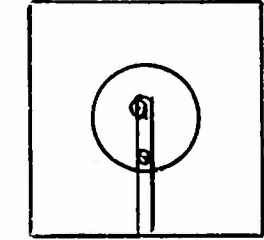

Long Surface Groove

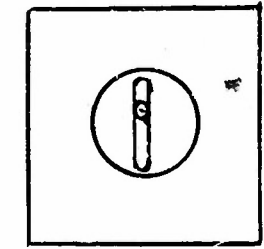

Short Surface Groove

REV NO. 166HA153
 CONT ON SHEET SH NO. 11

TITLE Corona Intensity vs
60 cycle voltage stress in Teflon (0,
 FIRST MADE FOR 100% RI

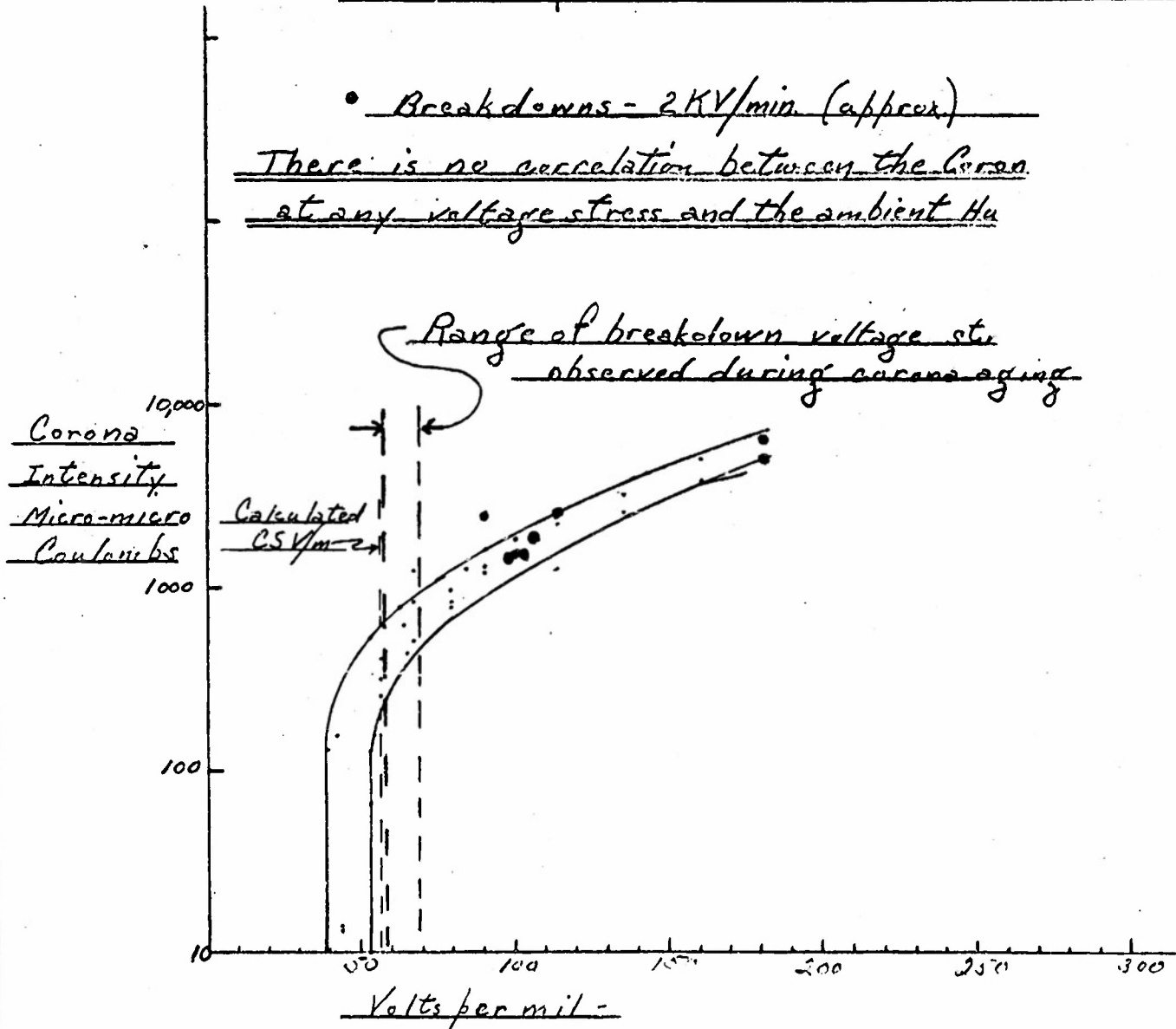

REVISIONS	PRINTS TO

MADE BY W.T. Starr
 ISSUED Nov 10, 1953

APPROVALS
Gen. Eng. Laboratory
Schrieffer WORKS

166HA153
 CONT ON SHEET SH NO.

VII. MATERIALS

This section contains much of the data upon which the conclusions in the foregoing sections were based. The corona intensity vs voltage data was obtained from tests upon two samples at each humidity. Wherever the variation between these two samples or between samples at various humidities was found to be small upon a study of the complete data, only one curve was plotted and the range of the data it covers is indicated.

The chance that the variation between any two samples will result in significant contributions to corona aging is extremely slight.

The data on some materials is not presented at this time because the complete range of humidity has not yet been covered.

Only steady corona indications are recorded here. The conclusion that flashover occurs when the corona intensity reaches the range of 40,000 to 100,000 micro-micro coulombs may, therefore, appear to be out of line with some of this data. Sporadic corona, however, always reaches into this range before flashover occurs.

1. Muscovite Mica

The samples tested had a range of thicknesses from 7 to 21 mils. Here, therefore, we have an ideal system for studying the effect of dielectric thickness on corona. The corona starting voltages were derived mathematically as well as obtained experimentally. Figure 11 shows the fair correspondence obtained between calculated and experimental values. For the derivation, an applied voltage of 1000 volts was assumed, and it was noted that the curves of air gap voltage stress vs gap distance converged for all the thicknesses used above 8 mil gaps. Thus, it is to be expected that the more intense corona (occurring above 2 times corona starting voltage) will be a function of applied voltage rather than dielectric voltage stress. This is noted (See Figure 12). This behavior is common to thin insulations where the ratio of T/K is less than 5.

The flashover voltage, however, is a function of sample thickness (See Figure 13). This is probably due to the closer coupling between the charging and discharging forms of corona on the opposite sides of the sample obtained at smaller thicknesses.

Comparison of Calculated and observed values of Corona Starting Voltage Stress for Muscovite Mica.

166.HA.154

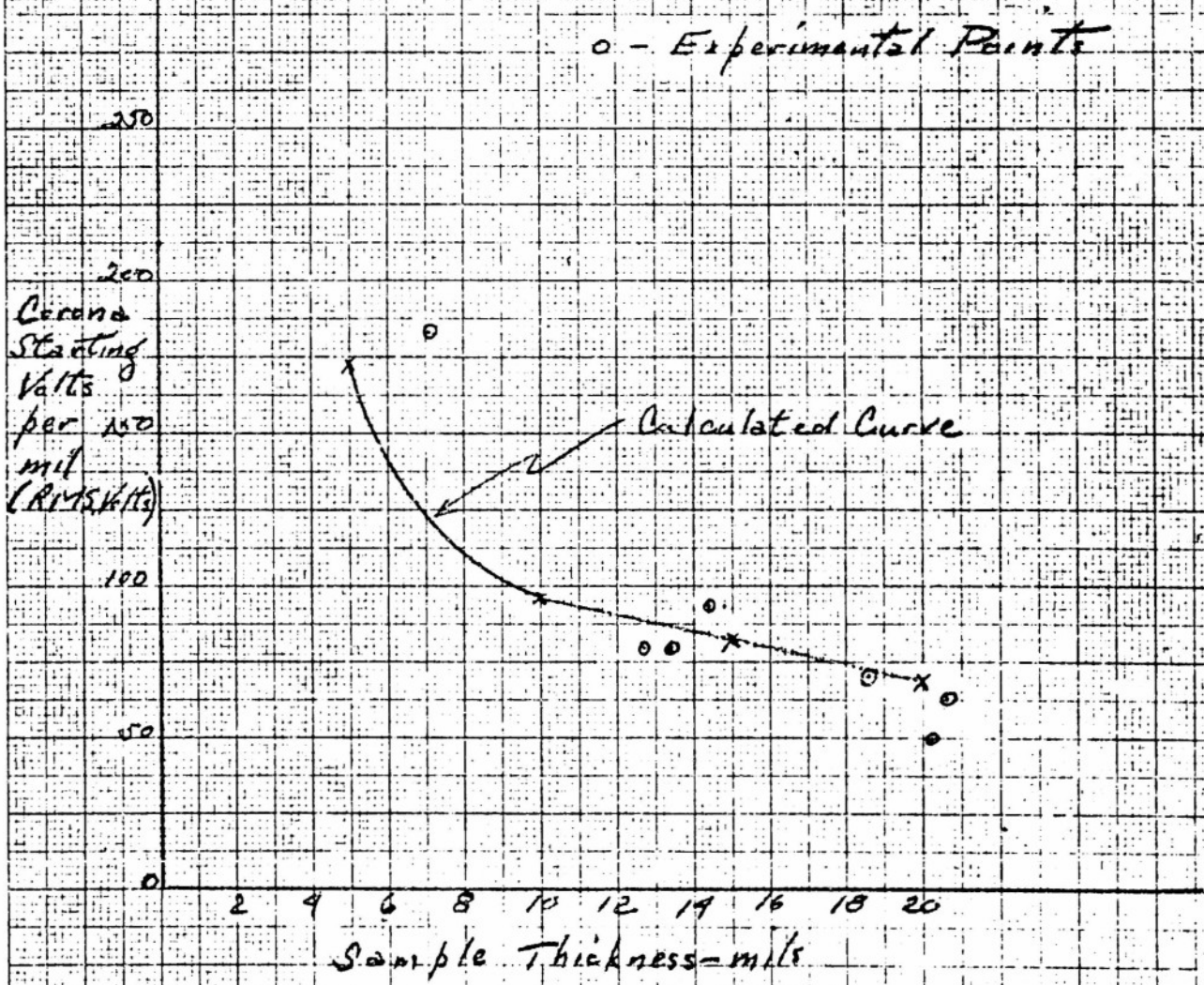

W.T. Starr
 General Engineering
 Laboratory
 Nov. 17, 1953
 166.HA.154

Figure 11

REV NO. 166 HA 155
 CONT ON SHEET SH NO.

TITLE Corona Intensity vs Voltage
for Massvite mica 7.1 to 20.6 mils thick
 FIRST MADE FOR

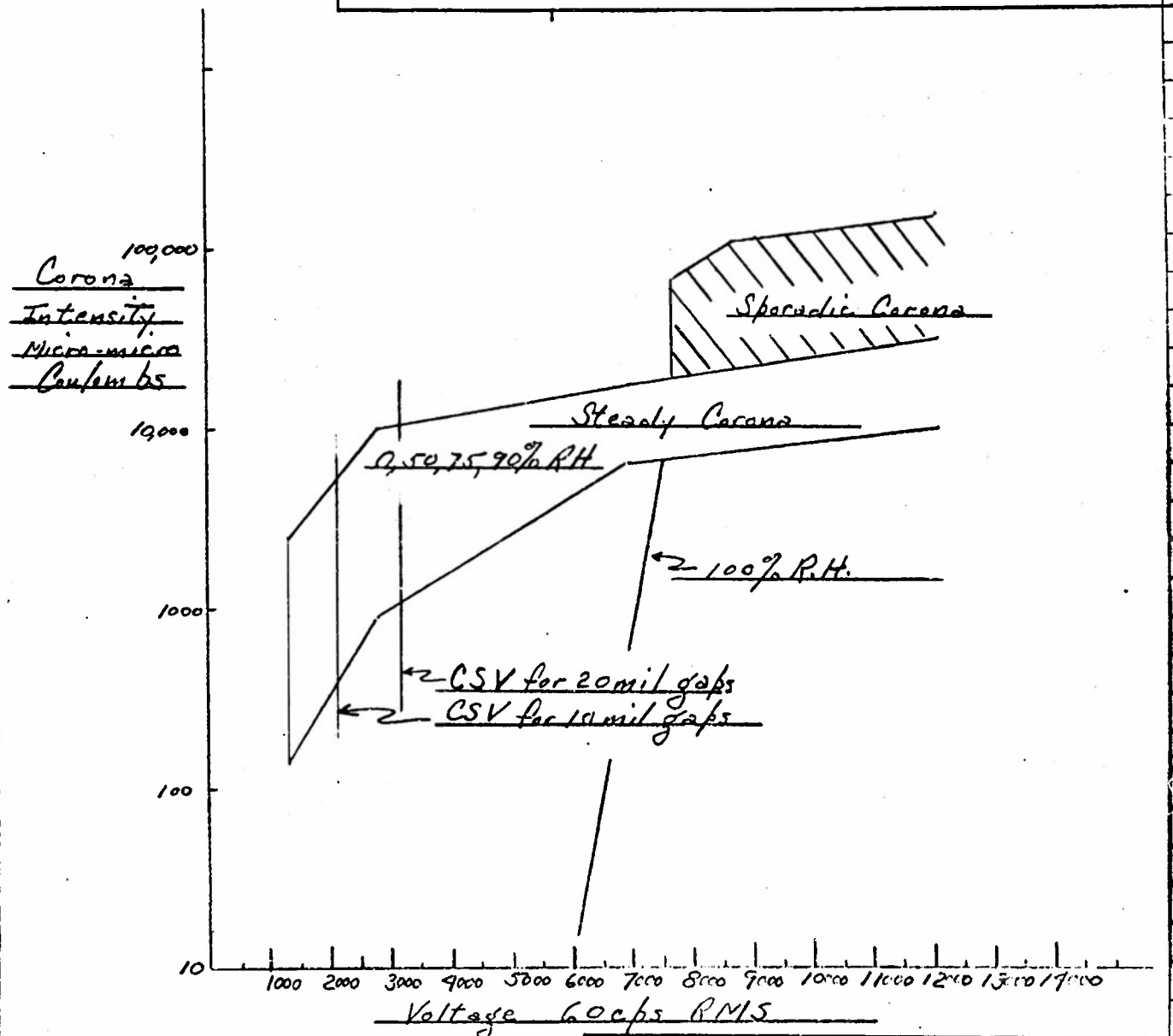

REVISIONS	PRINTS TO

MADE BY W.T. Starr
 ISSUED Nov. 17, 1953

APPROVALS
[Signature] DIV
[Signature] WORKS

166 HA 155
 CONT ON SHEET SH NO.

Flashover Voltages of Mica (Muscovite) samples
as a function of sample thickness

166HA156

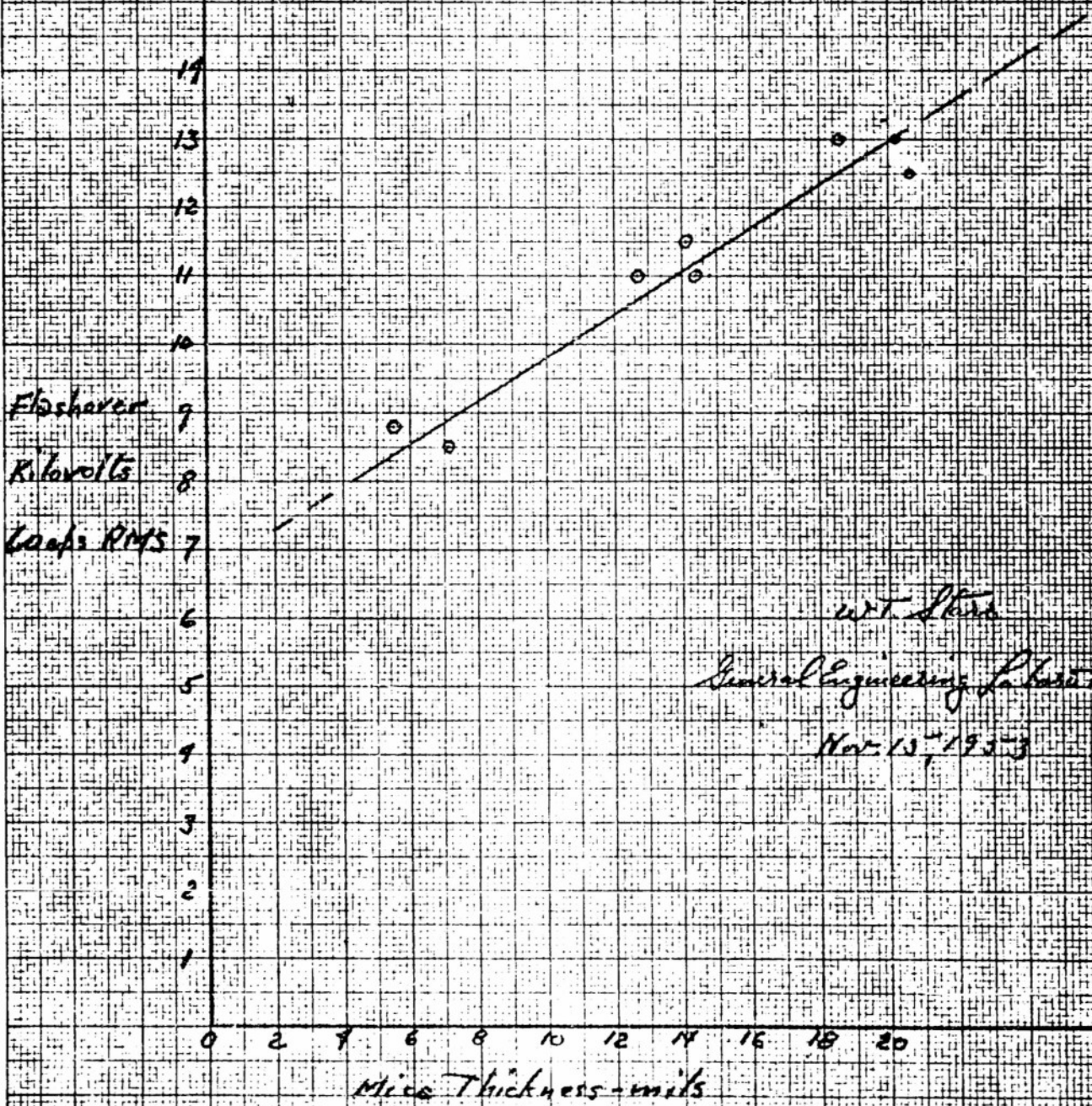

Flashover
Kilovolts
Graph RMS

W.T. Stur
General Engineering Laboratory
Nov 13, 1953

166HA156

2. Pyrex Glass

Changes in ambient humidity alter the surface resistance of pyrex over a wide range of values. This is reflected in large changes in the corona intensity vs voltage plot with ambient humidity. See Figure 14. At low relative humidities, the corona intensities at voltages above corona starting voltage are much higher than at high humidities.

This is undoubtedly because the glass surface becomes conducting enough to carry a large portion of the charging current required for the dielectric. This is also reflected in a lowering of the voltage stress required for flashover from 470 volts per mil at 0 and 50% RH to about 425 volts per mil at 75, 90, and 100% RH.

REV NO. 166 HA 157
 CONT ON SHEET SH NO.

TITLE Effects of Humidity on Corona Intensity on Pprox
 FIRST MADE FOR

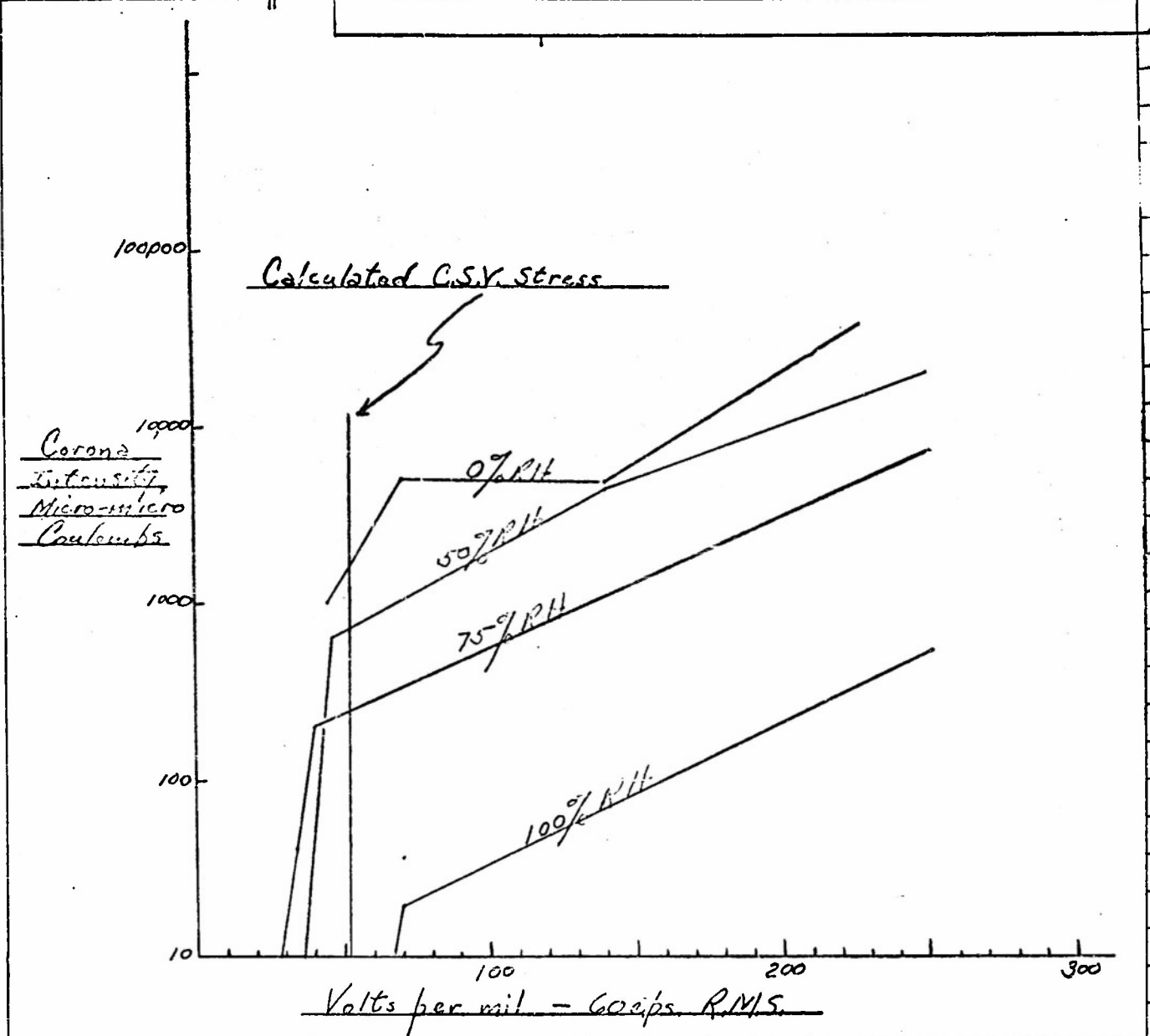

REVISIONS	PRINTS TO

MADE BY W. T. Stearns APPROVALS General Engineering Lab 166 HA 157
 ISSUED Mar-15, 1953 WORKS Schweitzer CONT ON SHEET SH NO.

3. Cellulose Acetate - Tenite I

The effects of humidity on surface corona on this material are shown in Figure 15. The reduction in corona intensities with increasing relative humidity is smaller than noted on Pyrex, but is appreciable.

REV NO. 166HA 158

TITLE Effects of Humidity on

CONT ON SHEET

SH NO.

Corona Intensity on Cellulose Acetate

CONT ON SHEET

SH NO.

FIRST MADE FOR

Tests at 25°C

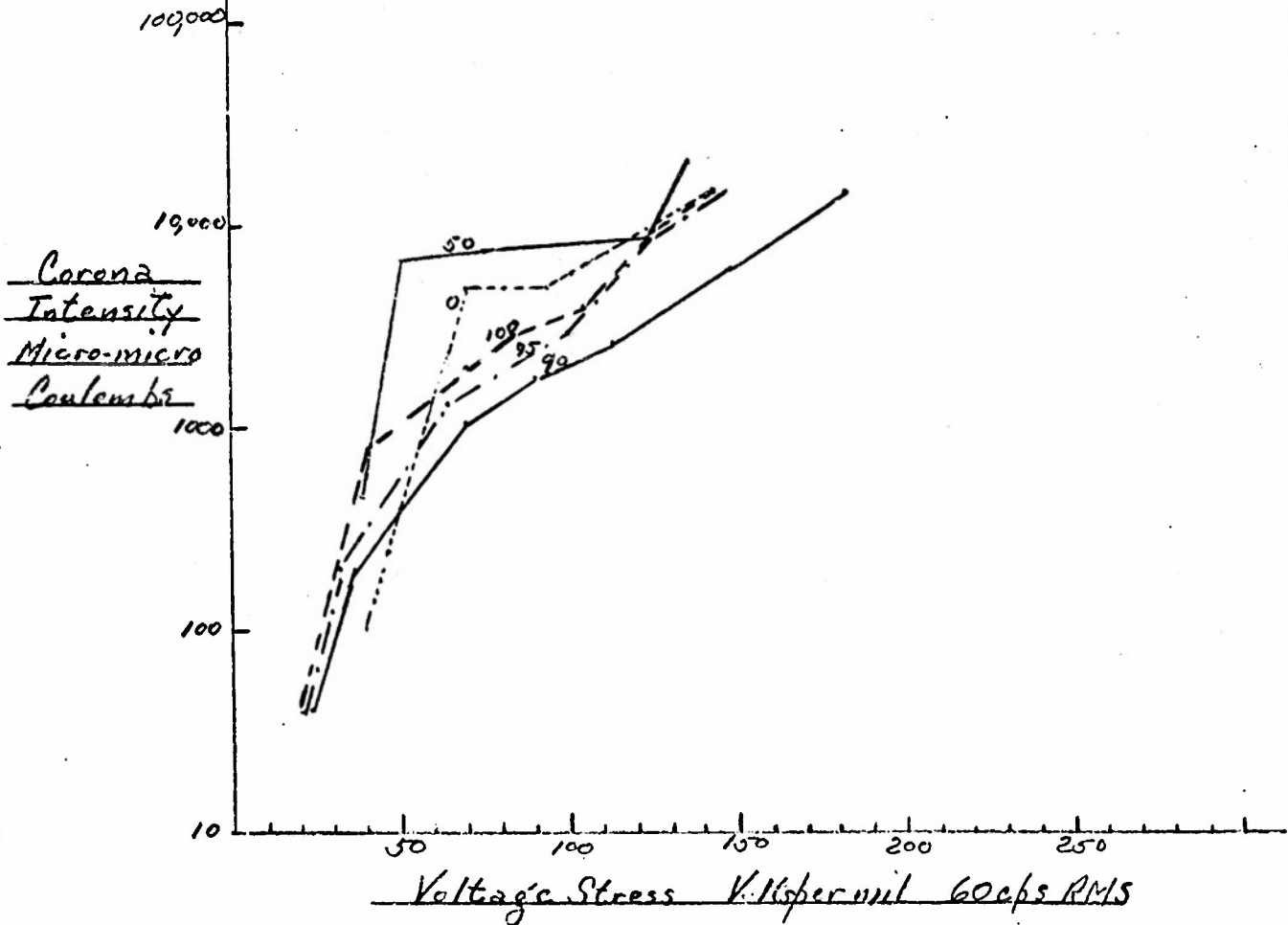

REVISIONS	PRINTS TO

MADE BY W.T. Starr
 ISSUED Nov. 17, 1953

APPROVALS
Engineering Dept DIV
Production WORKS

166HA 158
 CONT ON SHEET SH NO.

4. CR-39 Homalite

This material is a transparent colorless thermosetting resin with exceptional resistance to abrasion and solvents. It is a polyester.

Both the corona intensity and flashover voltage are affected by humidity as shown on Figure 16.

REV NO. 166 HA 159

TITLE Effects of Humidity on Corona Intensity on CR-39 Homalite

CONT ON SHEET

SH NO.

CONT ON SHEET

SH NO.

FIRST MADE FOR

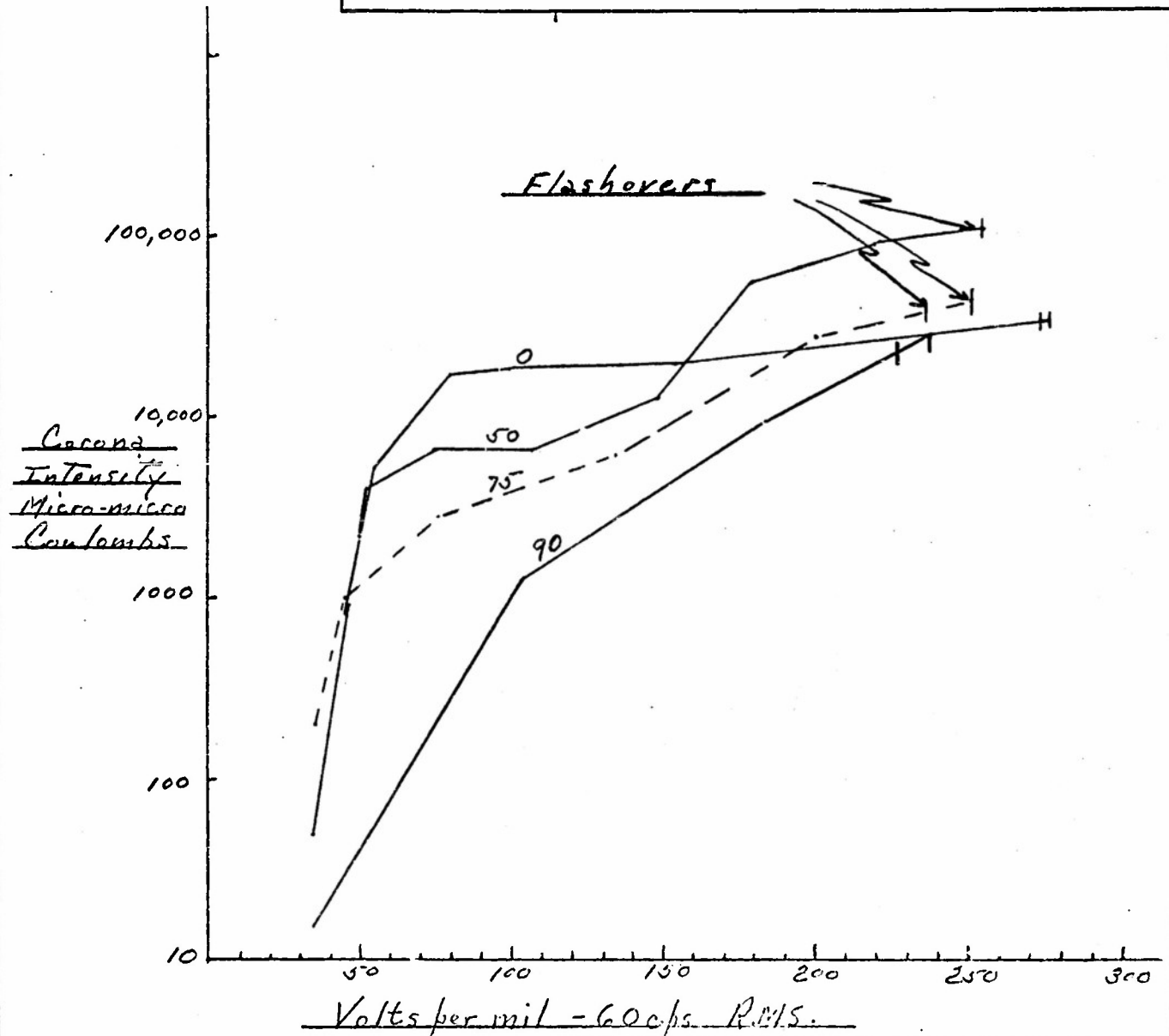

REVISIONS

PRINTS 10

MADE BY W.T. Stutz

ISSUED May 17 1959

APPROVALS Engineering Lab DIV

10-10 WORKS

166 HA 159

CONT ON SHEET

SH NO.

5. Teflon-Glass

The effect of humidity on surface corona on Teflon-Glass Laminate is small, but measurable. Flashover voltages are also lowered by high humidity by about 15%. Since polyethylene behaves almost identically, these effects are considered to be independent of the glass. It is very probable that they reflect changes in the dielectric strength of the air surrounding the sample more than the sample material or structure.

The surface corona data is plotted on Figure 17.

REV NO. 16611A-160

TITLE Effect of Humidity on Surface Corona on Tel-lon-Glass Laminate

CONT ON SHEET SH NO.

CONT ON SHEET SH NO.

FIRST MADE FOR

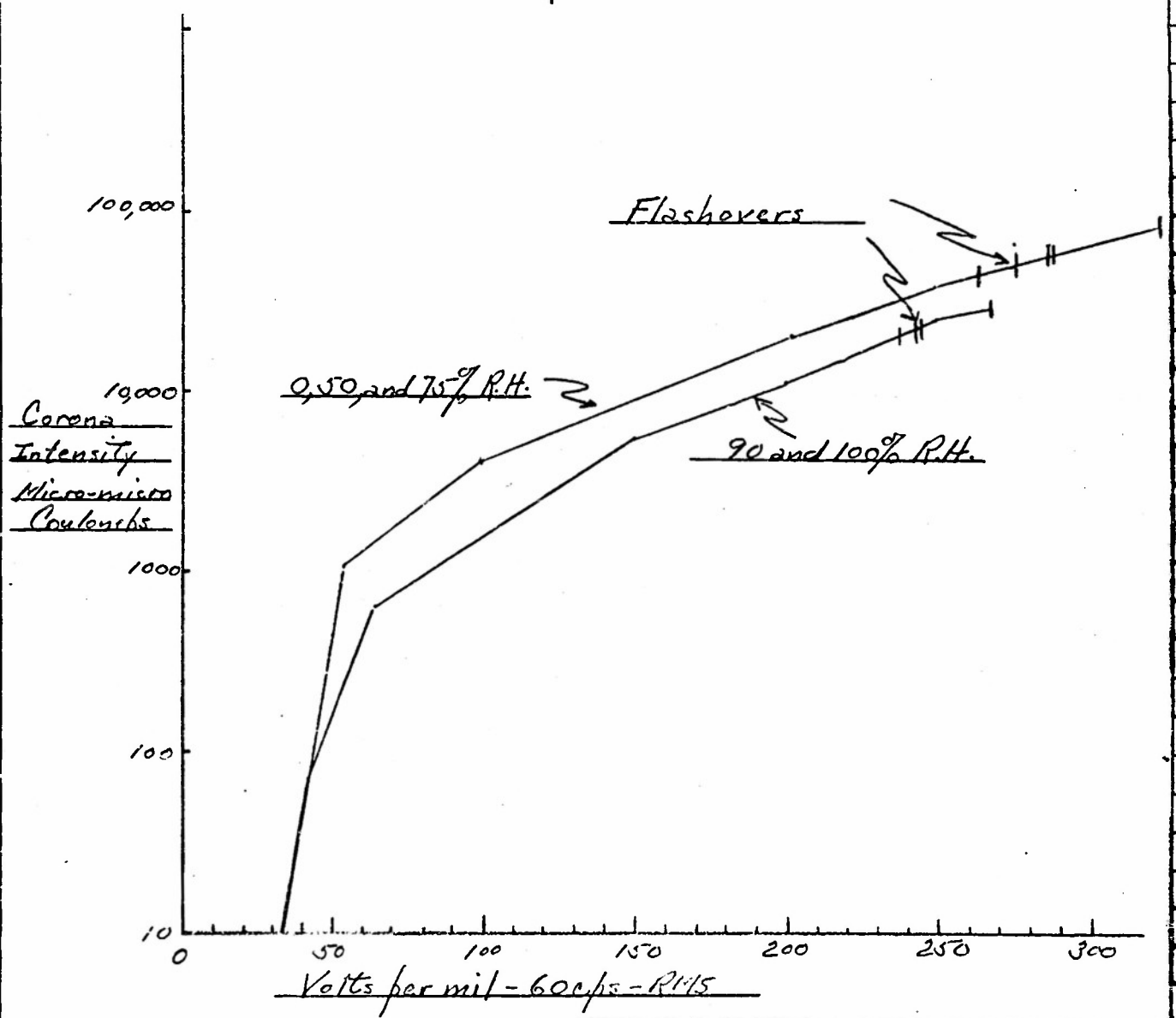

REVISIONS	PRINTS TO

MADE BY W.T. HARR

ISSUED 5-17-1939

APPROVALS Gen. Eng. Laboratory

WORKS

16611A-160

CONT ON SHEET SH NO.

6. Polyethylene

This material behaves very similarly to Teflon-Glass Laminate. The variations observed are probably due to changes in the dielectric strength of air with changing moisture content. The corona starting voltage is changed to almost the same degree by increasing humidity as is noted on much more hygroscopic materials. (See Figure 18).

REV NO. 166HA 161
 CONT ON SHEET SH NO.

TITLE Corona Intensity vs 60 cycle voltage stress for Polyethylene at 0, 50, 75, 90 and 100% RH. and 25°C
 FIRST MADE FOR

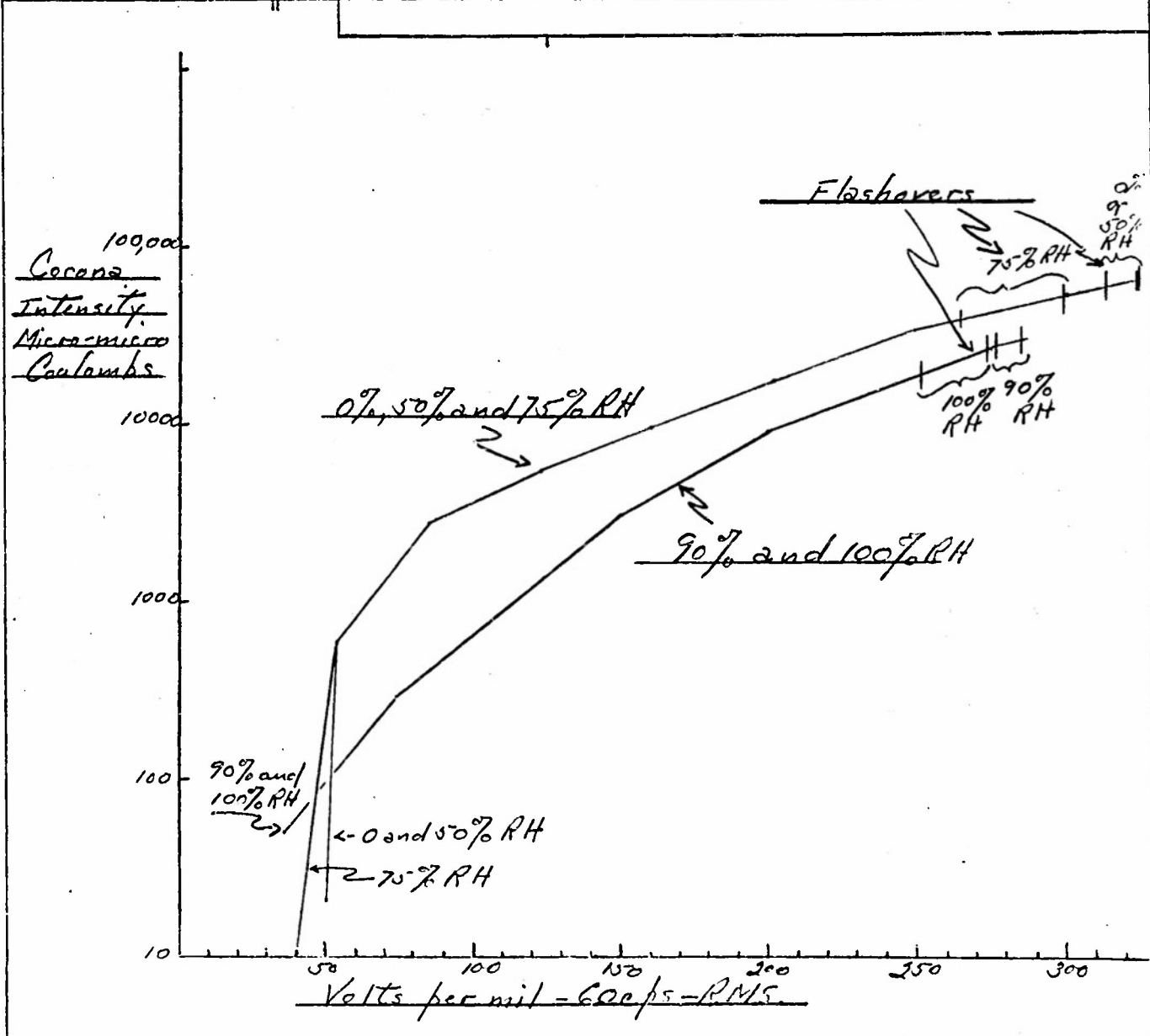

REVISIONS	PRINTS TO

MADE BY W.T. Stone APPROVALS [Signature] DIV 166HA 161
 ISSUED Dec. 7, 1957 WORKS CONT ON SHEET SH NO.

7. Nylon FM-3003

This material shows the intense corona noted close to the corona starting voltage on high dielectric constant materials at 0% RH. The variation of the data with changing humidity is indicative of a high value of surface resistivity even at high humidity (See Figure 19). The 50% RH value of surface resistivity for Nylon is 3×10^{15} which is equal to that of CR-39 and higher than those of Paraplex P-13, Cellulose Acetate, Hard Fibre, Plasticized Polyvinyl Chloride and Pyrex. The variation of surface resistivity with humidity was not determined.

REV. NO.	166 HA 162	TITLE	Corona Intensity vs 60 cycle voltage stress for Nylon (FM 2003) at 0, 50, 75, 90 and 100% RH at 25°C
CONT ON SHEET	SH. NO.	FIRST MADE FOR	

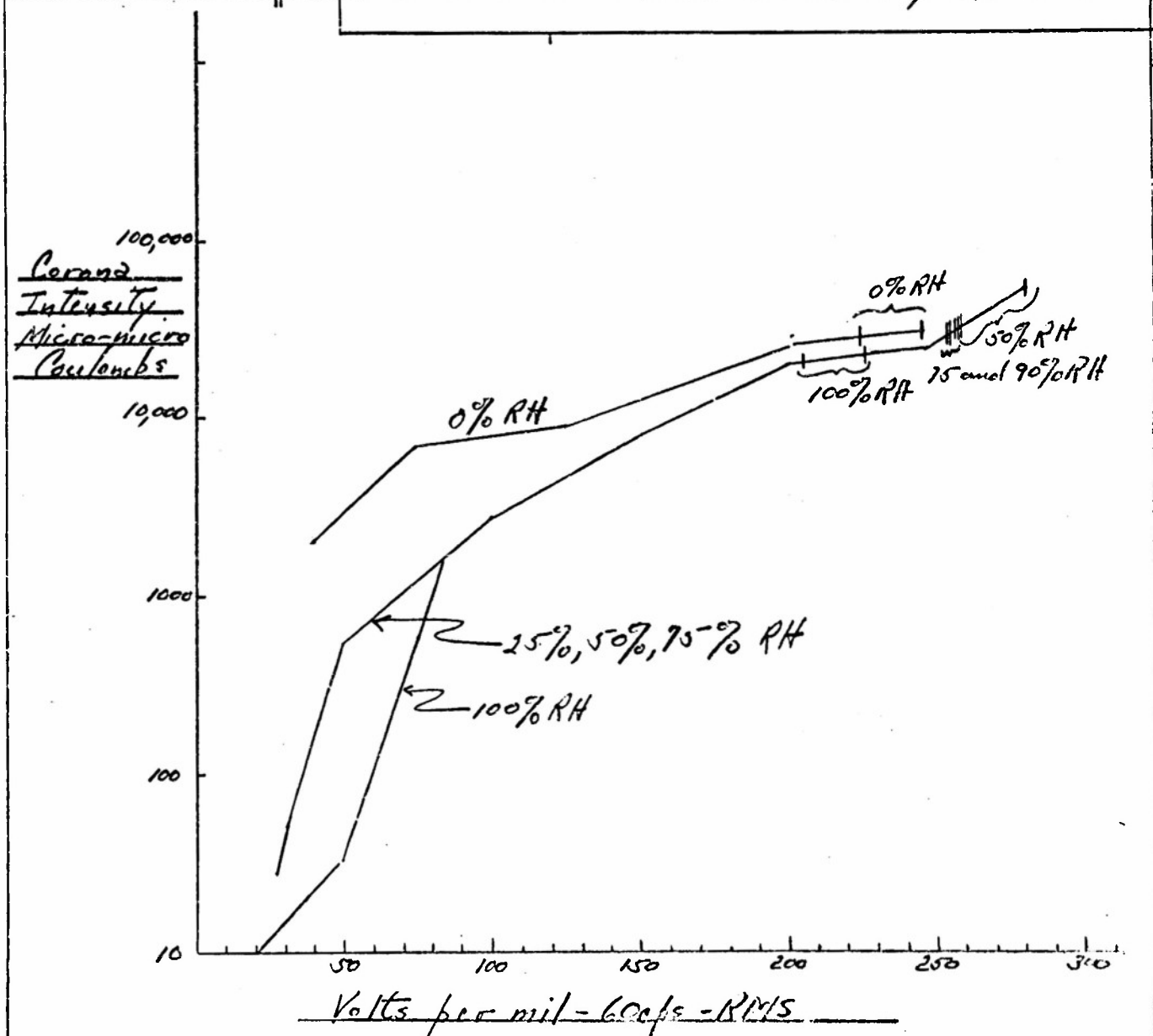

REVISIONS	PRINTS TO

MADE BY	W.T. Starn	APPROVALS	General Engineering Lab	166 HA 162
ISSUED	Dec 7 1953		Schneestadt	
		WORKS	CONT ON SHEET	SH. NO.

8. Commercial Grey Vulcanized Fibre (Grade 2 1/2)

In the Hard Fibre study, we have a picture of the ways that a combined thermal and corona breakdown can develop and the evidence of the imminence of this breakdown furnished by corona. At 0 and 50% relative humidity flashover preceded the development of dielectric breakdown conditions. At 75%, 90% and 100% relative humidities, however, corona stemming from the edge of the electrode heated the insulation and increased the losses in this region until breakdown occurred. Apparently, the losses of the insulation have increased to a point where space charge cannot prevent the entrance of the corona energy into the dielectric. Thus, a run away thermal condition developed at the electrode edge and breakdown occurred during the rapid bubbling and foaming of the insulation which ensued.

The corona evidence of this condition is shown on Figure 20. The corona starting voltage is lowered with increasing humidity as shown in Table 5.

TABLE 5

Effect of Relative Humidity on Corona Starting Voltage Stress of Hard Fibre

<u>% RH</u>	<u>Corona Starting Voltage Stress</u>
0	28
50	21
75	13
90	11
100	10

The voltage stress required to produce intense corona is also reduced, but the difference between 75% humidity where thermal-corona breakdowns occur and 50% where flashovers occur is not as clearly differentiated as at low corona intensity levels.

REV NO. 166HA 163

TITLE Corona Intensity on Grey Vulcanized Fabric at 0, 50, 75, 90 and 100% RH

CONT ON SHEET

SH NO.

CONT ON SHEET SH NO.

FIRST MADE FOR

Hawaii

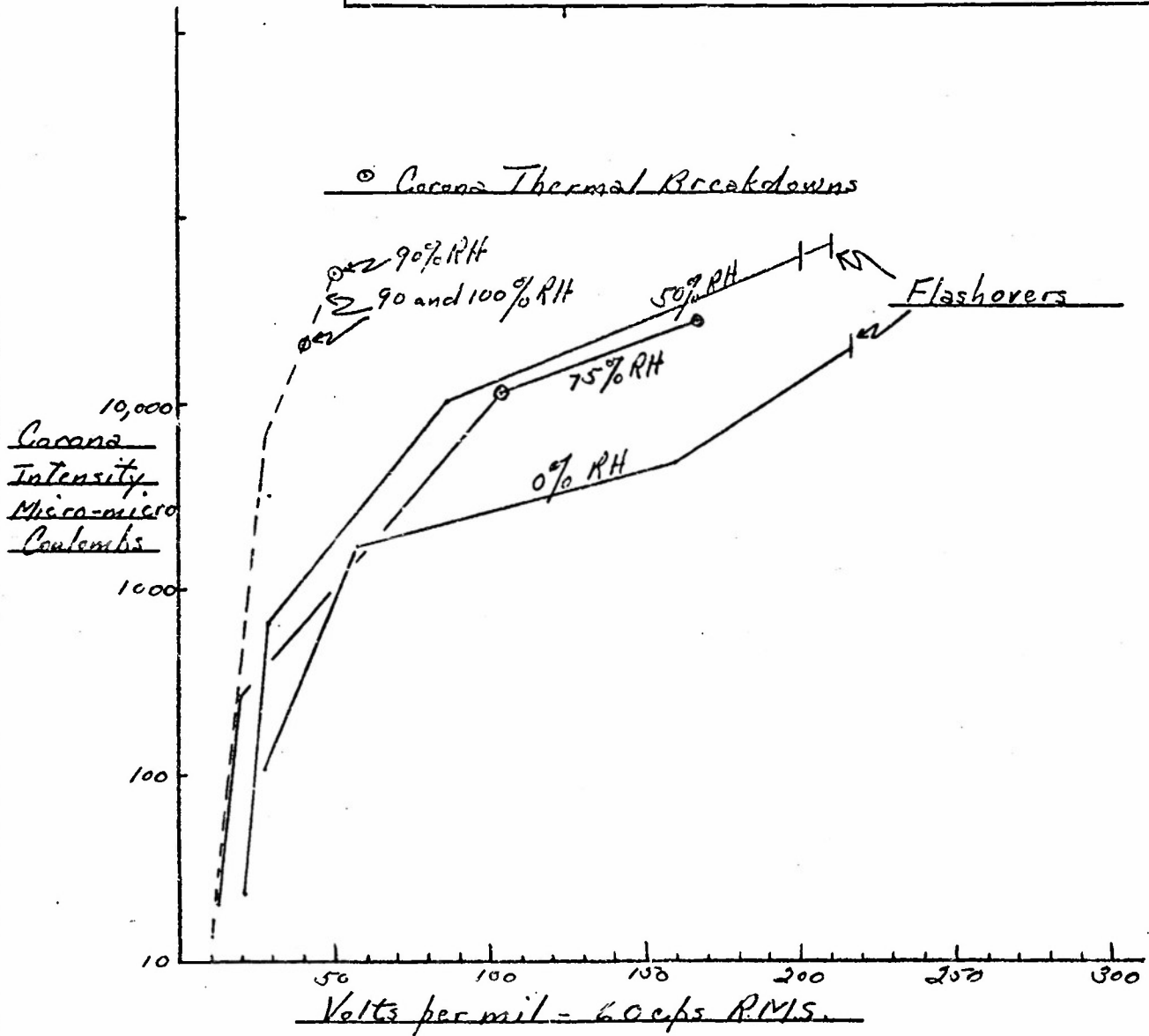

REVISIONS

PRINTS TO

MADE BY W-T Stern
ISSUED 7/18/1953

APPROVALS

General Eng. Lab. DIV
Science Dept. WORKS

166HA 163

CONT ON SHEET

SH NO.

VIII. APPENDIX

A. Ionization Pulse Waveshape -- Its Significance and Observation

In the usual 60 \sim ionization observation in dielectrics, the onset of the discharge is determined by observing the pulses of discharge on a 60 \sim time base in a circuit which has been often described as a modified "Quinn" type. Such data are reasonably accurate in determining at what stress the discharge begins in a steady fashion; their significance regarding waveshape, however, is small since the circuit employed determines the frequency observed (upon expanding the time base, the damped oscillation seen is the result of the circuit constants used, not a property of the material under study).

Waveshape studies in discharges from point-to-plane (and other geometries) have been reported from time to time where the discharges took place in gases of various types and at various pressures, in some cases with solid dielectrics introduced between the electrodes. No detailed study of the waveshape of current on voltage pulses of interval voids in dielectrics has been made to the present time to my knowledge. It is expected that such a study could reveal, in the least, some qualitative information regarding the mechanisms of the internal discharges and the attendant relationships of damage or degradation of the dielectric itself; leading finally to failure of the material as an insulator.

The measurement of the frequency spectrum of the corona pulses alone cannot reveal the waveshape since only amplitude and frequency are determined in these measurements; whereas, the phase of these components is also required to uniquely establish the waveshape. Direct observation of the pulse shape is the simplest approach and only the details of how to do this remains. The following sketch should establish the technique being employed in this study.

By employing fast enough sweeps, which are synchronized with the phase of the high voltage applied to the specimen under study, the exact parts of the cycle at which discharges occur can be isolated and by gating these sync pulses to the driven sweep of the scope, photographic recording of single sweeps may be accomplished.

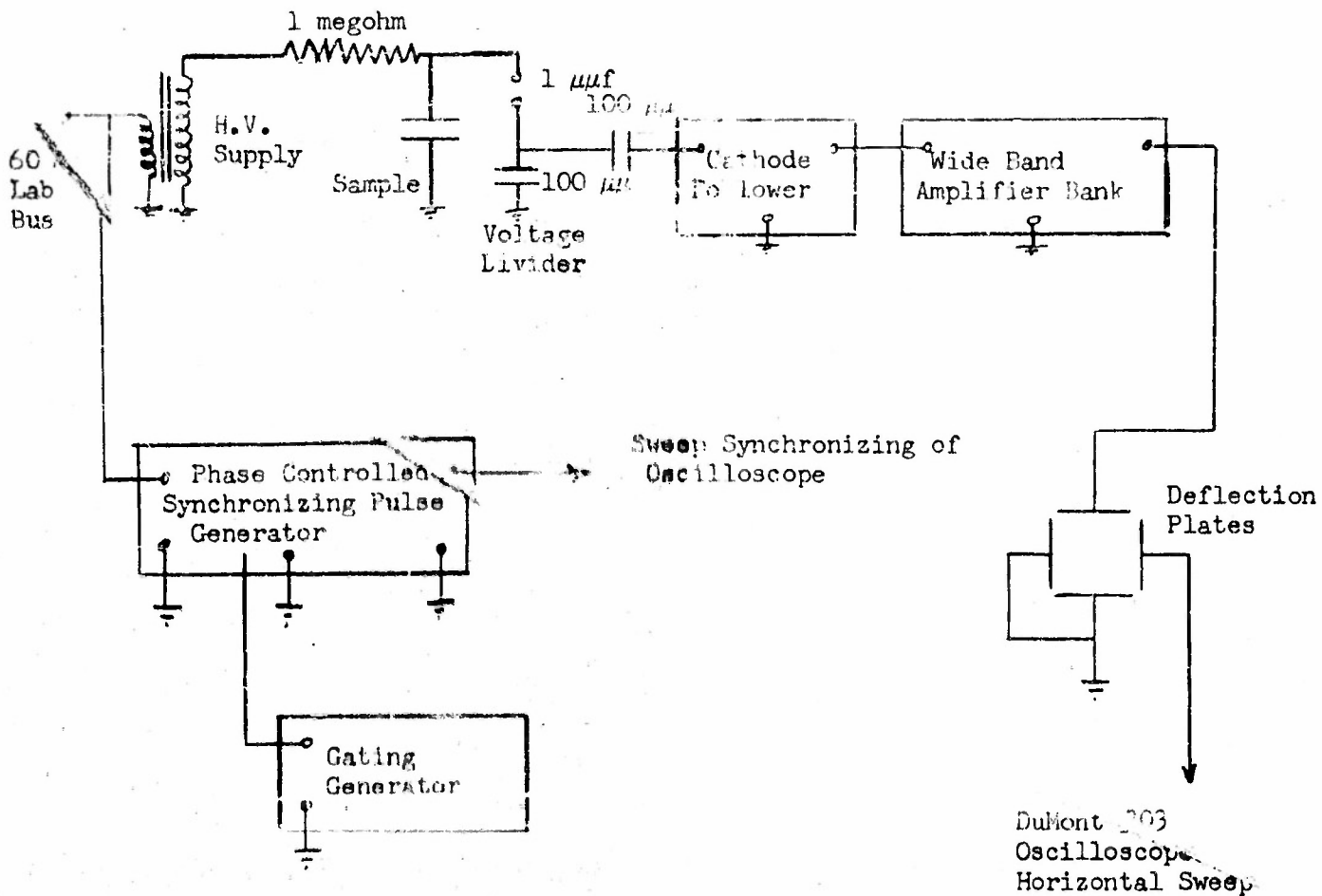

As indicated in the sketch, the voltage waveform of discharge is observed. Insertion of a series resistor of small value (a few hundred ohms) in the ground lead of the sample and capacitive coupling will yield current waveshape. The choice of coupling capacitor as well as the band pass of the amplifiers used, removes the 60 cycle components from the observed signal.

The pulse shapes observed should be indicative of the time sequence of events in the discharge and as such should yield valuable information concerning the types of mechanisms involved in the void and on the bounding dielectric surfaces. Since these mechanisms determine the damage done to the dielectric, and ultimately the length of time an insulator can withstand such discharges; a correct interpretation of these waveshapes should correlate closely to life test data of dielectrics and consequently, such data might replace the long time requirements of life-testing and become a means of rapid evaluation of dielectric life properties. The present recording difficulties are getting a sweep speed fast enough to give good resolution, with pattern intensities bright enough to record photographically.

B. Calibration Procedure for Ionization Testing

The charge content of an avalanche (measured in coulombs) is defined as corona intensity. When this charge is removed from the electrodes of the test sample, a change in voltage occurs. If ΔQ is the charge content in coulombs of the avalanche, C is the capacitance of the test sample as measured; ΔV is the voltage change; then $\Delta Q = C \Delta V$ (very closely). Since ΔV is measured as a deflection observed on an oscilloscope, a calibration method is used whereby the deflection in inches per volt is obtained. This method is depicted on Figure 21. In it, the test capacitance is charged to a known d-c voltage and discharged through a quick acting switch into the resonant circuit. This closely resembles the way that corona is believed to occur in the circuit and, therefore, results in a reliable value of volts per inch for calibration.

Now

$$Q = C \left[\frac{V}{\text{in.}} \right] \text{ in.} = (K) \text{ in.}$$

C. Corona Intensity in Internal Voids

When corona occurs in voids within the dielectric, however, this calibration is no longer valid. In order to determine the relation between apparent and actual corona intensities in such internal voids, a calculation was made and the result confirmed by experiment. According to this calculation, if C_d is the series capacitance of the dielectric in the ionizing region and C_v is the capacitance of the void then $Q = (K) \left(\frac{C_v}{C_d + C_v} \right) \times \text{inches } \mu\mu \text{ Coulombs}$. This ratio $\frac{C_v}{C_d + C_v}$

is not a measurable quantity, but an estimate of its value can be made from an inspection of the void thickness, sample thickness, and dielectric constant. In the case of the 25 mil deep void used in this study and a 100 mil thick sample

$$\frac{C_v}{C_d + C_v} = \frac{3}{K + 3}$$

where K is the dielectric constant of the sample. A general equation covering all possible test samples would be

$$Q = K \frac{t_d - t_a}{t_d + t_a (K-1)} \times \text{inches } \mu\mu \text{ Coulombs}$$

where t_a and t_d are the thickness of the void and the dielectric respectively.

REV NO.

166HA-167

TITLE

Calibration Circuit for
Corona Test

CONT ON SHEET

RH NO.

CONT ON SHEET

SH NO.

FIRST MADE FOR

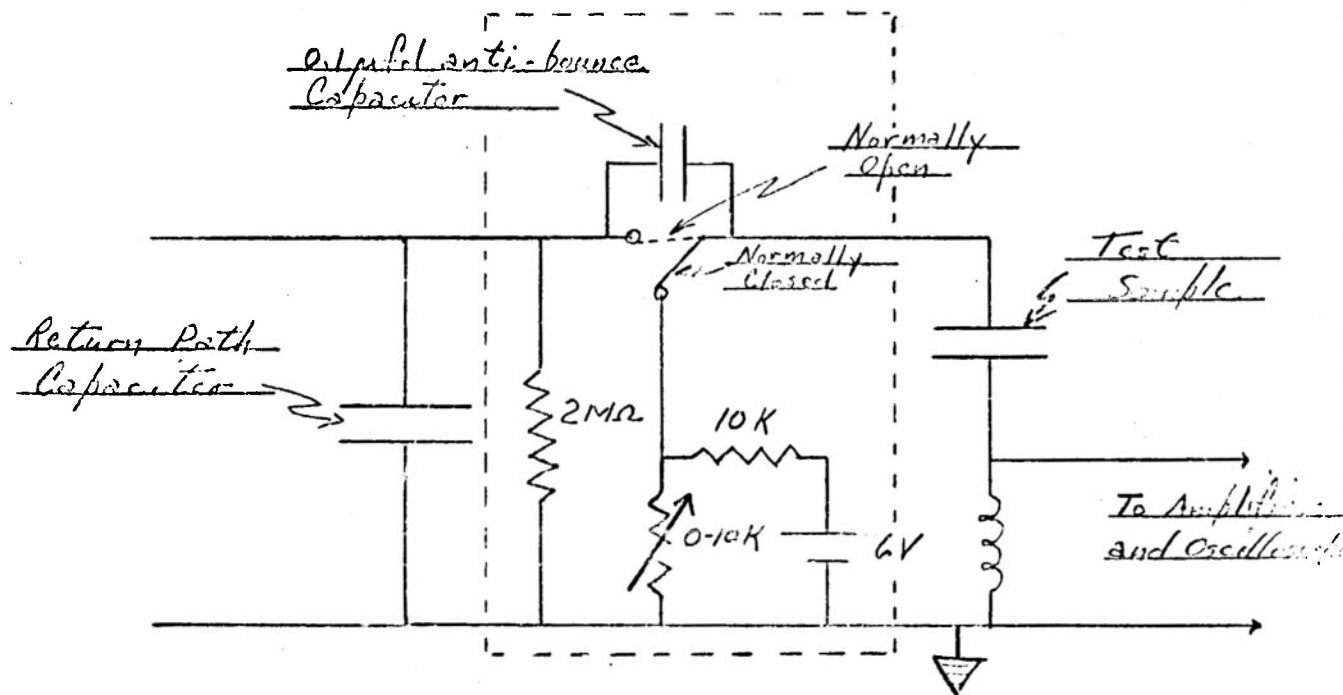

Calibration Circuit is within enclosure
Corona Test Circuit is outside enclosure

REVISIONS

PRINTS TO

MADE BY

ISSUED

10/11/53
Nov 11 1953

APPROVALS

General Engineering Lab. Div.
S. L. ...

166HA 167

WORKS

CONT ON SHEET

SH NO.