

AD No. **28 293**

ASTIA FILE COPY

NEW YORK UNIVERSITY

COLLEGE OF ENGINEERING

•

RESEARCH DIVISION



Project Report 183.02

BF₃ COUNTERS

Prepared for

OFFICE OF NAVAL RESEARCH

Nuclear Physics Branch, Washington, D.C.

Contract No. N6 ONR 279 T.O. 12

THIS REPORT HAS BEEN DELIMITED
AND CLEARED FOR PUBLIC RELEASE
UNDER DOD DIRECTIVE 5200.20 AND
NO RESTRICTIONS ARE IMPOSED UPON
ITS USE AND DISCLOSURE.

DISTRIBUTION STATEMENT A

APPROVED FOR PUBLIC RELEASE;
DISTRIBUTION UNLIMITED.

NEW YORK UNIVERSITY
College of Engineering
Research Division

THE EFFECT OF CONTAMINANTS ON THE OPERATIONAL
BEHAVIOR OF BF_3 COUNTERS

Project No. 183

Report No. 183.02

Approved by: Nancy Dorny
Nancy Dorny

Approved by: Serge A. Korff
Serge A. Korff
Project Director

Harold K. Work
Harold K. Work
Director of Research Division

OFFICE OF NAVAL RESEARCH
Contract No. N6 ONR 279, T.O. 12

NEW YORK, 1954

Acknowledgments

The author wishes to take this opportunity to express her thanks to Professor S.A. Korff, under whose direction this work was performed. The research was supported in part by the program of the ONR.

Introduction.....	1
Theory of proportional counters.....	3
Experimental method	
Equipment.....	6
Experimental procedure	
Introduction.....	7
Purification and filling procedure....	8
Results	
<u>First Filling</u>	
Description.....	12
Tests of plateaux.....	12
Discussion.....	13
<u>Second Filling</u>	
Description.....	14
Tests of plateaux.....	15
Discussion.....	16
<u>Third Filling</u>	
Description.....	18
Tests of plateaux.....	19
Discussion.....	19
Conclusion.....	21
Bibliography.....	22

INTRODUCTION

Although boron trifluoride (BF_3) counters have been used since 1939¹ for neutron detection, the effect of various contaminants on their operational behavior has not been systematically investigated.

There are several methods of purification of BF_3 gas. Most techniques necessitate contact of the gas with reactive substances. An example is the reaction of the gas with organic substances, particularly stopcock grease. Inert contaminants such as argon (A) are sometimes added to the BF_3 fillings to improve the characteristics of the counter. It is desirable, therefore, to investigate the effect of these contaminants on the counting characteristics of the gas.

The results that are obtained with a given purification and filling procedure are not always reproducible; methods that had been satisfactory on one occasion have not always proved so on others. Therefore, a purification and filling procedure for BF_3 gas, based on existing methods, must first be developed which will result in gas fillings whose counting characteristics are satisfactory and reproducible. This procedure would then be modified by the results of the study

1. Korff, S.A., and Danforth, W.E., *Phy.Rev.* 55, 980(1939)

of the effect of contaminants on the fillings.

This experiment was intended to:

1. Study the effect of reactive contaminants (organic) on the counting characteristics
2. Study the effect of argon on the counting characteristics
3. Study the effect of various cathode materials on the counting characteristics
4. Develop a purification and filling procedure which will produce satisfactory BF_3 gas fillings whose counting characteristics are reproducible.

THEORY OF PROPORTIONAL COUNTERS

Neutron detection by boron trifluoride filled counters depends on the $B^{10}(n,\alpha)Li^7$ reaction. Since the passage of neutrons will not produce a pulse, neutrons are detected by the subsequent ionization resulting from a secondary action. The disintegration products formed by the interaction of a neutron and an atom of a suitable filling gas, such as BF_3 , supplies such ionizing particles.

In order to detect neutrons therefore, BF_3 counters must distinguish between the heavy ionization of the resulting α particle and recoil Li^7 nucleus, and the smaller ionization produced by β and γ rays. (β and γ rays are almost always produced by the neutron source and the natural radioactivity of the surroundings.) Therefore, BF_3 counters must be operated in the proportional region to differentiate among the ionizing particles.

When a counter is operating in the proportional region, the resulting pulse height is proportional to the initial amount of ionization, the mean coefficient of gas amplification being the factor of proportionality. Since the coefficient of gas amplification depends on the accelerating voltage, the pulse height increases with increasing voltage on the counter, but at any chosen voltage, the value of the gas amplification is constant, regardless of the amount of initial ionization. Therefore, if we have two pulses of dif-

fering heights resulting from different initial ionizing particles, the ratio of the two pulse heights at the threshold of the proportional region, (that voltage which is just sufficient to produce secondary electrons by collision), will be maintained throughout the voltage range corresponding to the proportional region. The end of the proportional region is characterized by a dependence of the gas amplification on the initial amount of ionization, since interference of adjacent avalanches in the discharge decreases the total amount of ionization. As a result, the gas amplification for the initially greater ionizing particles does not increase as fast with increases in voltage as does the gas amplification of the lesser ionizing particle. Hence, the ratio of the two pulse heights gradually decreases as the voltage is increased (region of limited proportionality), until the Geiger region is entered, where the final pulse height is independent of the initial amount of ionization.

The characteristic counting rate curve of a counter is obtained by plotting the number of pulses greater than a selected height as a function of accelerating voltage. By choosing a minimum pulse height at the beginning of the proportional region, it is possible to record only pulses corresponding to the passage of neutrons and large ionizing events such as α particles resulting from radioactive contamination, and to eliminate the effect of β and γ particles which are numerous. Hence, the counting rate

curve will flatten, the number of counts per unit time remaining constant or increasing slightly (less than 5% per 100 volts) over the plateau. The plateau of the characteristic curve extends over the voltage range corresponding to the proportional region.

The length and rate of rise of the plateau of the characteristic curve will be the criteria of a satisfactory counter for neutron detection.

EXPERIMENTAL METHOD

Equipment

In order to permit a study of the characteristics of various cathode materials and to reduce the possibility of individual peculiarities, a number of counters of different cathode materials were attached to a manifold so that the identical gas filling would be present in each.

Nine counters were used, 3 with copper cathodes, 3 with stainless steel cathodes, and 3 with brass cathodes. The central wires were 4 mils in diameter, the cathodes were 25 cm long and $3\frac{1}{2}$ cm in diameter.

A 25 millicurie polonium-beryllium source provided the neutrons for testing the counters. The source was placed in the center of the circle formed by the counters, as shown in Diagram 1. The lead shield reduced the γ intensity from the source, and the water and paraffin reduced the velocity of the neutrons until their energies were thermal. The cadmium shield provided personnel protection.

The counters were attached to electronic circuits which consisted of Atomic Instrument Company's Model 206 A Impedance Transformer and Model 1050 Scaler. The latter device includes a power supply to 3000 volts, linear amplifier and pulse height discriminator. As used in this experiment, the amplifier gain was 2×10^4 , with a rise time of 0.3 microseconds, and a clipping time (RC time constant) of 0.33 microseconds.

The setting for the pulse height discriminator, which was 25 volts in this experiment, was based on a comparison of the counting rate as a function of discriminator setting with and without a cadmium shield on the counters. The minimum pulse height setting which most effectively reduced the counting rate with the cadmium shield on the counters could be obtained in this manner.

Experimental Procedure

Introduction

Since the detection of thermal neutrons depends on their interaction with the B^{10} nucleus, commercial BF_3 which contains only about 20% of the B^{10} isotope, is relatively inefficient when used as a filling gas. BF_3 , which has a 96% concentration of the B^{10} isotope can be prepared by heating the calcium fluoborate complex (CaF_2BF_3), as supplied by the AEC. The resulting gas must then be purified. Almost all previous generation and purification procedures^{2,3} used a glass container for the CaF_2BF_3 during gas generation, apparently on the assumption that no deleterious reaction occurs between BF_3 and glass at these temperature.

-
2. Tongiorgi, V.V., Hayakawa, S., and Widgoff, M., Rev. Sci. Instr. 22, 899(1951)
 3. Fowler, I.L., and Tunnicliffe, P.R., Rev. Sci. Instr. 22, 734(1950)

Booth and Martin⁴ state that glass is attacked by BF_3 at a temperature of 450°C with the production of silicon tetrafluoride (SiF_4), an undesirable electronegative gas. One might infer that below a 450°C temperature, the reaction is either nonexistent or slight. This inference is probably incorrect, since Hudswell et al⁵ have found that there is a definite reaction a little above 200°C . Since the temperature of the container for the CaF_2BF_3 is raised over 300°C during gas generation, it was believed advisable to substitute stainless steel for glass (Diagram 2).

Because of the strong reaction of BF_3 with oils and greases, the innate difficulties of vacuum work are increased when BF_3 is in the vacuum system. Within a few days of contact with the gas, the stopcock grease (Apiezon N) turns a dark brown and over a longer period will dry out, resulting in either frozen or leaking ground glass joints. The thermocouple gauge also loses sensitivity progressively, and is eventually destroyed by contact with BF_3 gas.

-
4. Booth, H.S., and Martin, D.R., Boron Trifluoride and Its Derivatives, Wiley (1949)
 5. Hudswell, F., Nairn, J., and Wilkinson, K.L., A.E.R.E. C/R 468, Corrosion Experiments with Gaseous Boron Trifluoride, June (1950)

Purification and Filling Procedure

Diagram 3 shows the entire vacuum system. The system can be divided into three main sections. The section marked "pump section" is a usual high vacuum arrangement. Essentially, it consists of a fore-pump, mercury diffusion pump and various gauges for determining the pressure. The liquid air traps remove water vapor and prevent mercury vapor from diffusing throughout the vacuum system. All the operations connected with generation and purification of the gas are conducted in the "purification section". The purified gas is then brought over to the "manifold section" for addition to the counters.

The following procedure was used for the first filling. Any modifications will be mentioned when each subsequent filling is discussed.

(1) All sections of the vacuum system were brought by the pumps to a "sticking vacuum" as read on the McLeod gauge (10^{-5} to 10^{-6} mm Hg). This pressure had to be maintained for at least 10 hours without pumping to assure that no air leaks would arise for the duration of the purification and filling operations.

(2) After this vacuum was obtained, each counter was outgassed at about 400°C by enclosing it with 2 infra-red lamps in an "oven" of aluminum foil. A final pressure of about 10^{-5} mm Hg was obtained after outgassing for a period

of 2 to 6 hours. The central wires were glowed for a short period to outgas them and remove any surface irregularities.

(3) Six grams of CaF_2BF_3 produced 1 liter of BF_3 at STP. An extra 15% of complex was allowed for loss during purification. The complex was placed in the stainless steel generator. If necessary, the outside of the lead gasket can be painted with Glyptal to insure a good seal.

(4) The complex was pumped until the pressure remained almost constant, and then the generator was heated. The temperature of the generator was maintained at 100°C - 110°C while pumping, until a pressure of 10^{-5} to 10^{-6} mm Hg was obtained. Usually, this process required 48 hours. The temperature of the generator was controlled by an asbestos-covered nichrome heater regulated by a Variac. The temperature was read on a thermometer inserted in a well in the base of the generator.

(5) The temperature of the generator was then raised to 140°C and a dry ice acetone bath was placed on Trap 2. Stopcock 5 was closed to the manifold and counters. Trap 1 was loosely packed with glass wool to catch any particles of the complex which might be carried over.

(6) The temperature of the generator was raised slowly. The pressure of the evolving BF_3 (as read on Manometer 1) usually begins to increase when the temperature had attained 225°C and remained steady after 325°C . When the pressure showed no further increases, the heater was turned off.

The reservoir flask provided sufficient volume for the BF_3 gas, preventing greater than atmospheric pressure being reached inside the vacuum system.

(7) A liquid air bath was placed around Trap 3 and the BF_3 gas was frozen out. The heater was removed from the generator and Stopcock 2 was closed to isolate the residual complex.

(8) After all the BF_3 has frozen into the trap, which only takes a few minutes, Stopcock 3 was opened to the pump section. The frozen BF_3 was pumped until the thermocouple gauge read its original value, corresponding to a pressure of 10^{-5} to 10^{-6} mm Hg. This pumping removed any impurities whose freezing point was below that of liquid air (-185°C).

(9) Stopcock 3 was then closed to the pump section, and the liquid air bath was removed from Trap 3 and the BF_3 allowed to evaporate. The gas was then refrozen and step 7 repeated. This refreezing and reevaporation was repeated until no deflection of the thermocouple gauge was noted when the frozen BF_3 was initially opened to the pump section. Generally, this required about 6 repetitions of steps 8 and 9.

(10) Stopcock 5 was opened to the manifold, and the BF_3 allowed to diffuse into the manifold and counter section. A liquid air bath was placed on Trap 4 to freeze all the gas from the various sections. (Stopcock 6 was closed to the pump section.)

(11) Stopcock 5 was then closed to the purification

section, and the liquid air bath was removed from Trap 4, allowing the BF_3 to diffuse into the counters. After sufficient time was allowed for diffusion, the stopcocks on the counters were closed.

RESULTS

Three separate fillings of the counters were made. The first filling represents a direct application of the purification procedure decided upon. The second filling was made to determine the effects of contaminants arising from reactions between BF_3 and organic materials. The third filling was made to investigate the effect of argon on the characteristic counting rate curves.

First Filling

Description:

The counters were filled to a pressure of 17.5 cm Hg with BF_3 . The frozen BF_3 , when first prepared, had a vermillion color which disappeared with subsequent purification.

Tests of Plateaux:

The counting rates were determined and are shown on Graphs 1-a, -b, -c. The plateaux for the stainless steel cylinder counters have a greater slope than any of the other counters.

The slopes of all the plateaux are satisfactory for operation as proportional counters, having less than a 5% increase per 100 volts.

No significance should be attached to the relative counting rates since the position of the source varied in this test. The counters were arranged horizontally and the source moved beneath them.

Discussion:

The purification procedure described previously produces satisfactory BF_3 counters. The test was repeated and the results show that the gas fillings have counting characteristics which are reproducible.

It is doubtful that the duration of the purification procedure could be shortened, since it is determined by the pumping time needed to remove the impurities. As a result, it was found necessary to outgas the complex for 48 hours until the desired pressure was obtained, rather than the much shorter time reported by other experimenters. Similarly, the number of repetitions of the evaporation and pumping of the BF_3 ice needed to purify it, was determined by the presence of foreign gases whose presence was revealed by the thermocouple gauge. In addition, the initial outgassing of the glass of the vacuum system and counters is also necessary to remove foreign gases. Although the

duration of one generation and filling procedure is sufficient to destroy the thermocouple gauge (RCA-1949), the greater sensitivity of the thermocouple gauge to pressure changes obviates the use of a manometer.

Although the plateaux of the stainless steel cathode counters had a greater slope than those of the brass or copper cathode counters, subsequent fillings show that extended outgassing of the stainless steel is all that is necessary to produce slopes comparable with those of the other counters. Originally, the stainless steel cathode counters proved the most difficult to outgas and could not be evacuated below a pressure of 5×10^{-4} mm Hg. Since there were separate stopcocks on the counters, any outgassing of the stainless steel cathodes that continued after filling the counters would be retained in each counter, and contaminate the filling. Outgassing for the remaining fillings was sufficient to reduce the slope of the plateaux of the stainless steel cathode counters to that of the other counters.

Second Filling

Description:

This filling was made to investigate the effect of contaminants arising from reactions of the BF_3 gas and organic materials, since the stopcock grease was reacting

with the filling. Octoil S was floated on the surface of the Hg in the manometers to accentuate any such effect. Simultaneously, covering the surface of the Hg prevented any Hg vapor from diffusing into the filling gas.

Mirror-like deposits had been found in the cooler sections of the counters after outgassing, which could have been Hg.

The counters were filled to a pressure of 17.5 cm Hg with BF_3 , after being thoroughly outgassed. The oil on the manometers became highly discolored and thick.

An attempt was made to repurify the gas after the characteristic curves were obtained, but it was found that the BF_3 gas could no longer be frozen by liquid air after exposure to the stopcock grease and oil. Despite this drastic change in physical characteristics, the counting characteristics remained the same.

Tests of Plateaux:

The characteristic curves for the counters, (Graphs 2-a, -b, -c), demonstrate the slight increase in the slope of the plateaux, resulting from the contaminants arising from a reaction between the BF_3 and the organic materials. Despite the length and slope of the plateaux remaining satisfactory for proportional counting in this case, the increase in slope is an undesirable feature. The amount of increase of the slope of the plateaux would be proportional to the

amount of organic materials present, as shown by comparison of the slopes of the plateaux for the first filling in which less organic material was present and those for this filling.

Copper cylinder counter 2 developed an air leak at a wire to glass seal resulting in a sharp increase in slope of its plateau (Graph 2-a). It was removed from the manifold.

Since the mirror-like deposit appeared on the cooler sections of the glass envelopes of the counters after outgassing, we may conclude that it was not Hg from the manometers, as originally supposed.

As noted in the discussion of the first filling, the plateaux of the stainless steel cathode counters is now comparable with those of the other counters.

Discussion:

The increase in slope when BF_3 is allowed to react with organic materials to produce HF is an effect presumably attributed to negative ions. Since HF is strongly electronegative, negative ions would be expected to be formed, and would manifest themselves as detectable pulses.

Low broad negative ion pulses (half width of 100 microseconds), lagging the initial electron pulse by about 300 microseconds, were observed by Tongiorgi et al² in tests of BF_3 counters. These experimenters found that a suffi-

ciently short clipping time apparently prevented the detection of the negative ion pulse.

Since there would be a distribution of delay times about the mean of 300 microseconds, some percentage of the negative ion pulses would arrive at the central wire while it was still influenced by the decaying voltage pulse of the previous electrons, and the resultant total voltage pulse would be sufficient to be detected. The possibility of completely eliminating the effects of negative ions by reducing the clipping time as suggested by Tongiorgi et al² is not substantiated by the results of this test.

The final pulse height in a proportional counter is independent of the distance from the central wire of the initial ionization when only electron pulses are considered. However, the electron loss by attachment to electronegative molecules results in a large pulse size distribution, decreasing the counter's usefulness as a neutron detector.

The large increase in slope of the plateau for the counter which developed an air leak (Graph 2-a), is attributed to a combination of both a negative ion effect and the increased ionization obtained in oxygen and nitrogen. The negative ions, O₂ and HF, would be formed from the water vapor of the air.

The metallic deposit found on the cooler sections of the glass walls of the counter after outgassing is probably released by heating from either the cathodes or the solder

used in constructing the counters. It was not removed by cleaning the counters.

Third Filling

Description:

The third filling was made to investigate the effect of argon on the plateaux. Since the cathodes of the counters were discolored and stopcock grease had melted and run into the body of the counters, the counters were cleaned very thoroughly. The counters were removed from the vacuum system, and washed in various solvents, such as carbon tetrachloride and trichloroethylene. They were then outgassed with infra-red lamps for about 10 hours.

Since no BF_3 is generated below 200°C , the temperature of the complex was raised to 160°C while open to the pump section without a dry ice acetone bath on Trap 2. The necessity for such a bath was questioned, since no deposit was found in the trap immersed in the dry ice acetone bath (-78.5°C).

The counters were filled to a pressure of 19 cm Hg with BF_3 . The purification section was filled with spectroscopically pure A almost to atmospheric pressure. One half cm Hg of A was added to the filling gas through Stopcock 5. After the counting rate curves were obtained at this pressure, $1\frac{1}{2}$

cm Hg of A was added making a total pressure of 2 cm Hg of A in the filling gas.

Tests of Plateaux:

The tests of the plateaux for the initial filling without A (Graphs 3-a, -b, -c) show that the plateaux were satisfactory for proportional counting. Neither the addition of $\frac{1}{2}$ cm Hg of A (Graphs 3-d, -e, -f), nor 2 cm Hg of A (Graphs 3-g, -h, -i), affected the position or slope of the plateaux appreciably. The total addition of 2 cm Hg of A decreased the counting rate for the stainless steel and copper cathode counters.

Graphs 3-j, -k, -l compare the characteristic curves for a representative counter of each cathode material when initially filled with BF_3 , and after $\frac{1}{2}$ cm Hg of A and $1\frac{1}{2}$ cm Hg of A had been added to the filling.

Discussion:

Since A had a low starting potential, the addition of A to the filling gas should lower the threshold of the plateau. Since operating a counter with the lowest possible voltage is usually a desirable feature, A has sometimes been added to BF_3 fillings. The change in the starting potential would depend on the relative amount of A added and the value of the gas amplification, being most effective for low gas amplification. No change in the threshold or slope of the plateaux was noted in this experiment, which result agrees with simi-

lar work performed by Tongiorgi et al².

It is noted on Graphs 3-j, -k, -l, the comparison of characteristic curves after A was added, that a 10 - 15% decrease in counting rate resulted after the addition of 2 cm Hg of A to the gas fillings of the copper and steel cathode counters. No reduction in counting rate occurred for the brass cathode counters for the same filling. This decrease in counting rate can be explained by assuming a sorption of the BF_3 by either the grease present or the metal cathodes occurred, leaving less BF_3 available for nuclear interaction. That this explanation is probably correct, is strengthened by consideration of the duration of contact of the filling gas with the counter materials before data was recorded. All the data except that resulting from the addition of 2 cm Hg of A to the filling gas of the copper and steel cathode counters was obtained within 3 or 4 days after filling the counters. The remaining data was obtained about 14 days after filling the counters. Since the stopcocks on the counters isolated the filling from the manometer, no direct verification of the suggested pressure drop can be given. In a similar filling, the pressure of the BF_3 was found to drop from 16.5 cm Hg to 12.0 cm Hg over a period of about 3 weeks.

CONCLUSION

(1) The purification procedure for BF_3 gas described in the text produces counter fillings whose counting characteristics are satisfactory and reproducible.

(2) BF_3 gas should not be allowed to come into contact with organic materials since the resulting electronegative molecules increase the slope of the plateaux. A metal vacuum system substituted for the glass to avoid the formation of SiF_4 by the glass and the BF_3 , and the elimination of all greases, would prevent any electronegative molecules from forming from these sources.

(3) The addition of 2.5% and 10% of argon to the filling gas did not lower the threshold of the plateaux, nor affect their length or slope. No desirable change resulted from the addition of argon to the filling gas of the counters. It should not be assumed that this would be true for all counter fillings. The addition of argon to a counter filling whose gas amplification differs from that obtaining in this test might result in a lowering of the threshold of the plateau.

(4) Copper, brass, and stainless steel were equally satisfactory as cathode materials. Care must be taken to outgas the cathodes sufficiently before the filling gas is added.

BIBLIOGRAPHY

- Booth, H.S., and Martin, D.R., Boron Trifluoride and Its Derivatives, Wiley, (1949)
- Fowler, I.L., and Tunnicliffe, P.R., Rev. Sci. Instr. 21, 734 (1950)
- Hudswell, F., Nairn, J.S., and Wilkinson, K.L., A.E.R.E. C/R 468, Corrosion Experiments with Gaseous Boron Trifluoride, June (1950)
- Korff, S.A., Electron and Nuclear Counters, D. Van Nostrand Co. (1946)
- Korff, S.A., and Danforth, W.E., Phys. Rev. 55, 980 (1939)
- Korff, S.A., and Present, R.D., Phys. Rev. 61, 38 (1942)
- Korff, S.A., and Present, R.D., Phys. Rev. 65, 274 (1944)
- Loeb, L.B., Fundamental Processes of Electrical Discharges in Gases, Wiley, (1931)
- Massey, H.S.W., Negative Ions, Camb. Univ. Pr., (1950)
- Rose, M.E., and Korff, S.A., Phys. Rev., 59, 850 (1941)
- Rossi, B.B., and Staub, H.H., Ionization Chambers and Counters, McGraw Hill, (1949)
- Tongiorgi, V.C., Hayakawa, S., and Widgorff, M., Rev. Sci. Instr. 22, 899 (1951)
- Wilkinson, D.H., Ionization Chambers and Counters, Camb. Univ. Pr., (1950)

COUNTER - SOURCE ARRANGEMENT

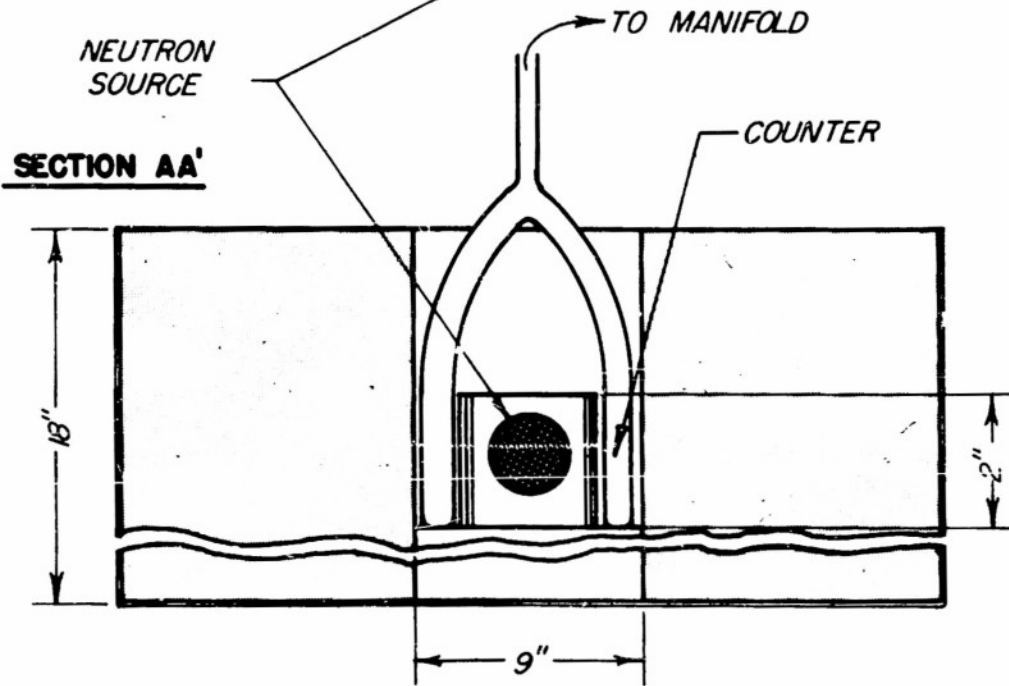
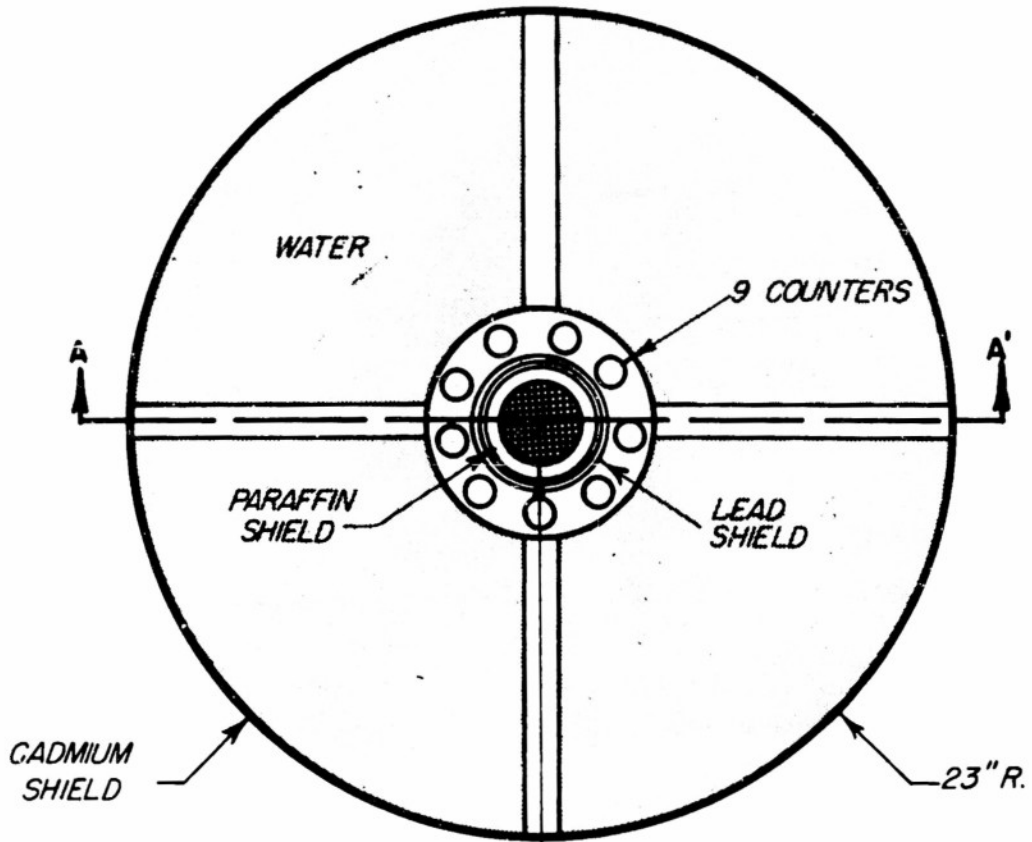
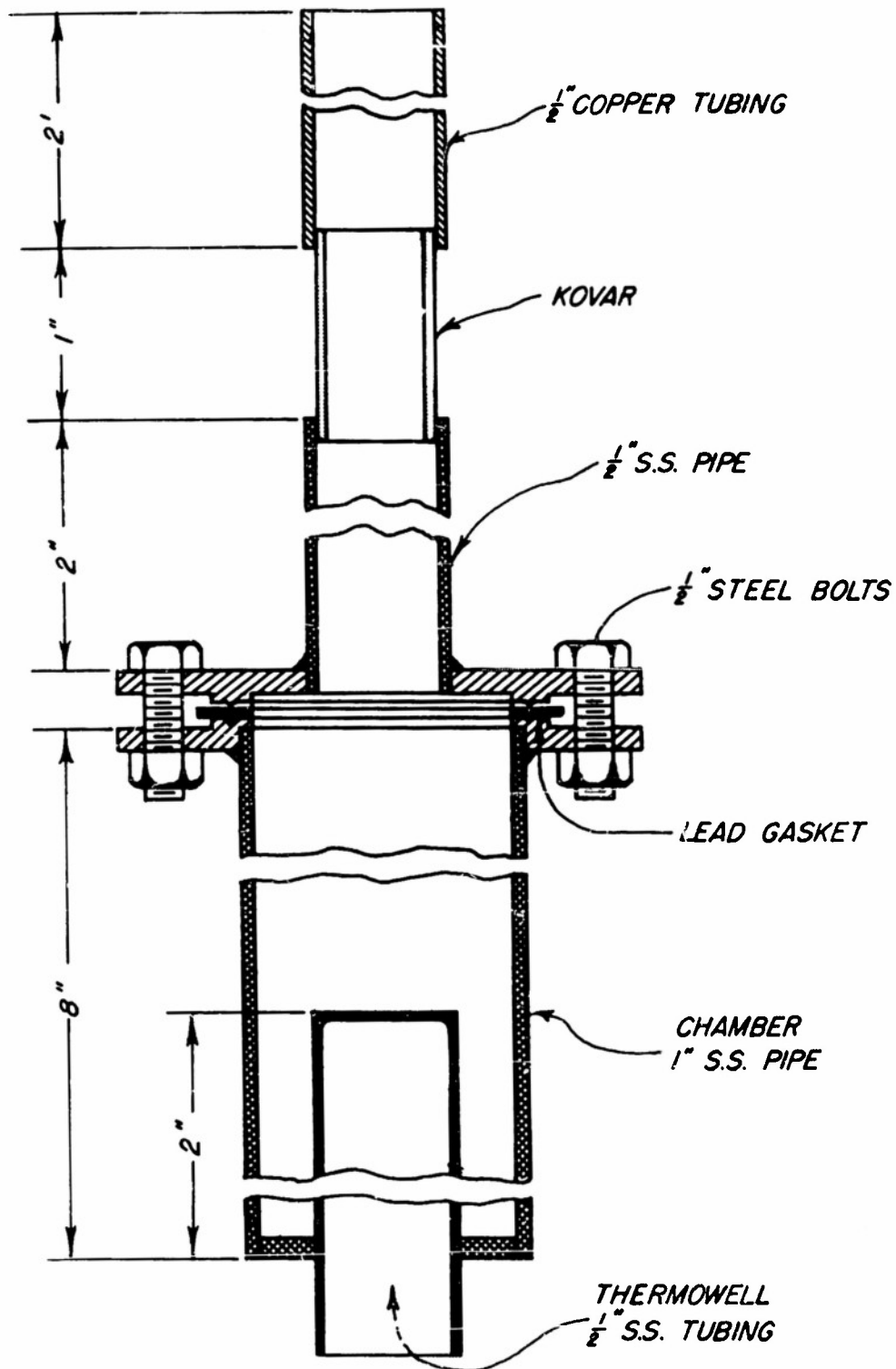

DIAGRAM I

STAINLESS STEEL GAS GENERATOR



ALL JOINTS ARE SILVER SOLDERED

DIAGRAM 2

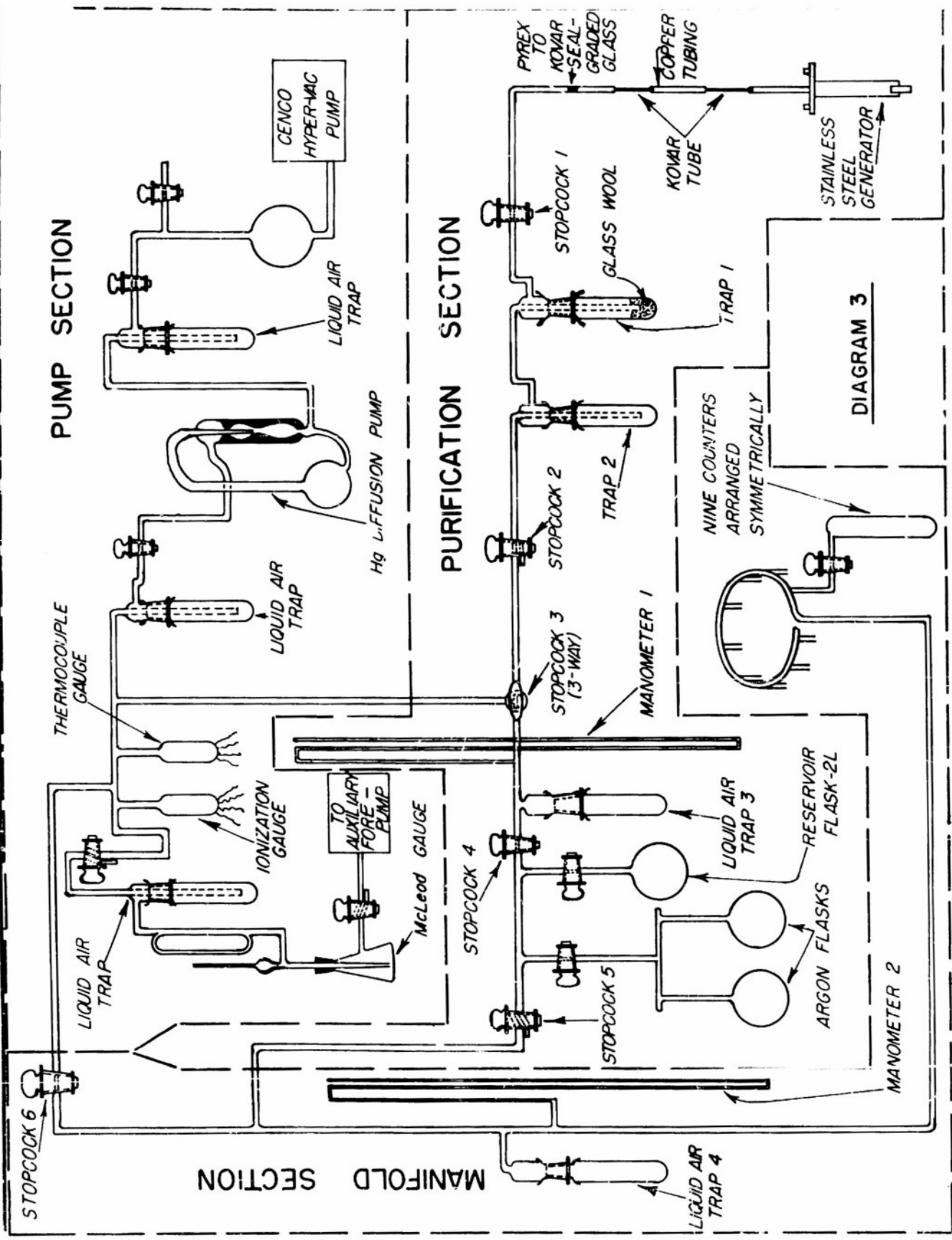

DIAGRAM 3

FIRST FILLING (COPPER CATHODE)



GRAPH 1-Q

FIRST FILLING (STEEL CATHODES)

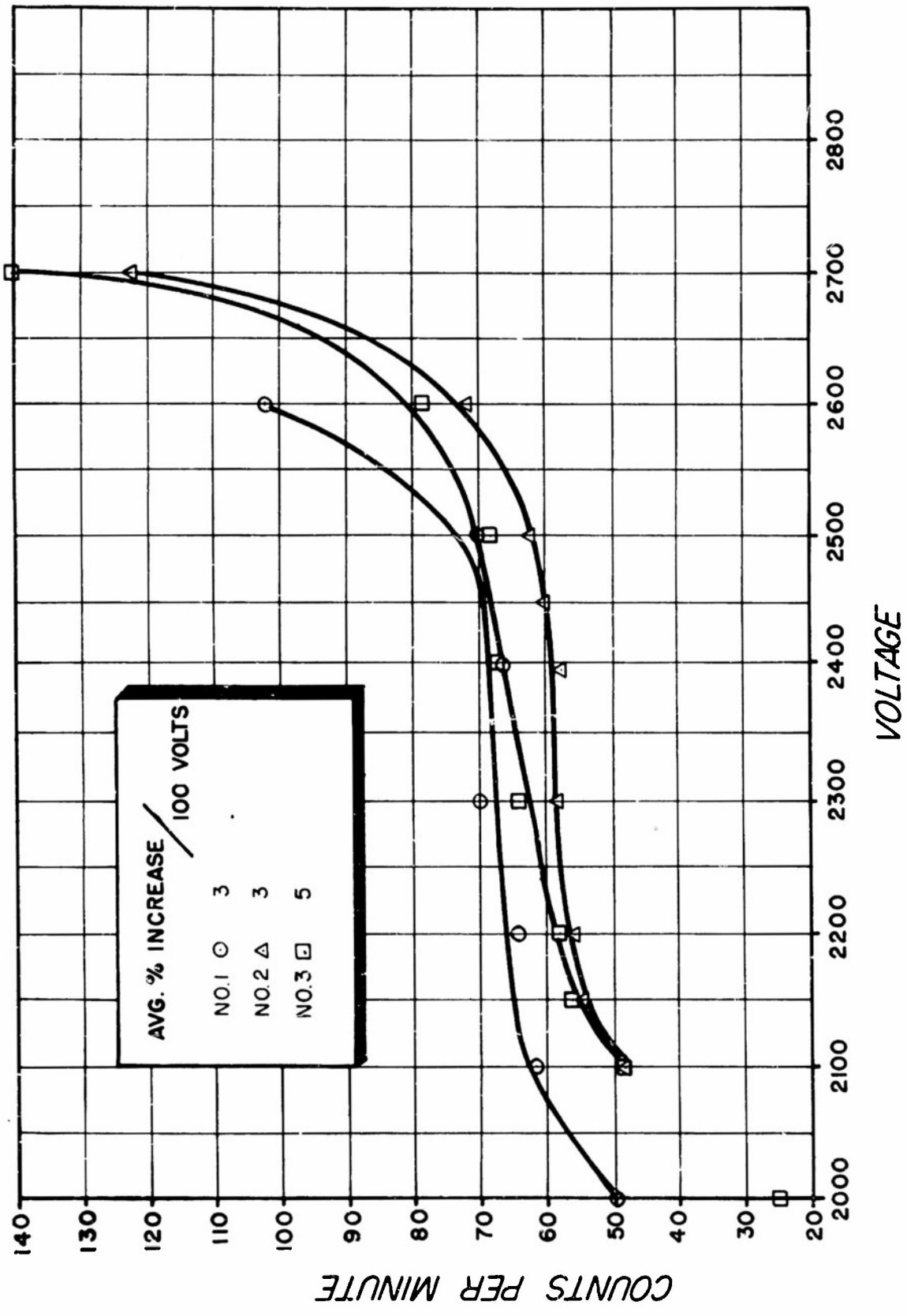

GRAPH 1-b

FIRST FILLING (BRASS CATHODES)

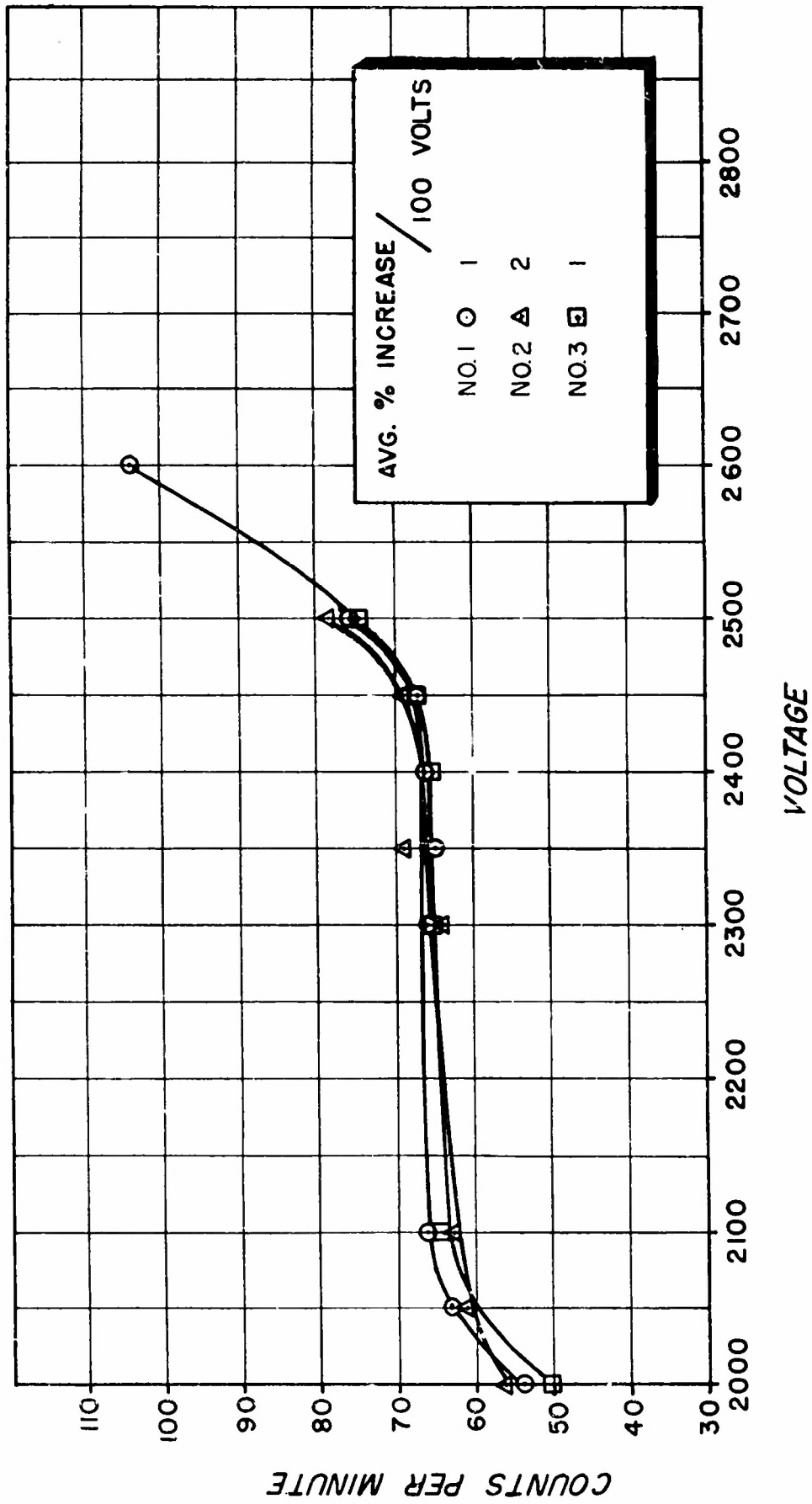

GRAPH I-C

SECOND FILLING (COPPER CATHODES)

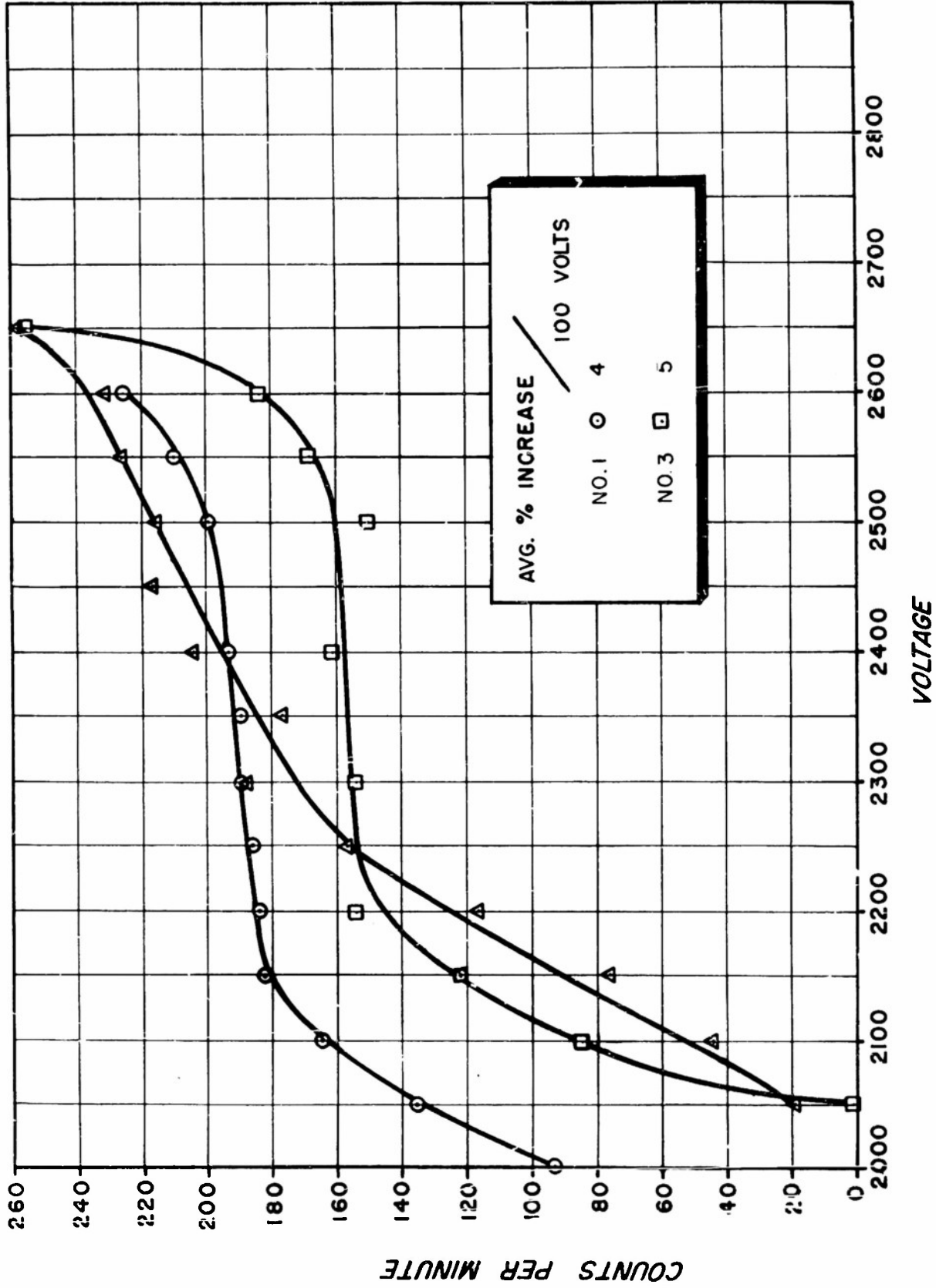

GRAPH 2-0

SECOND FILLING (STEEL CATHODES)

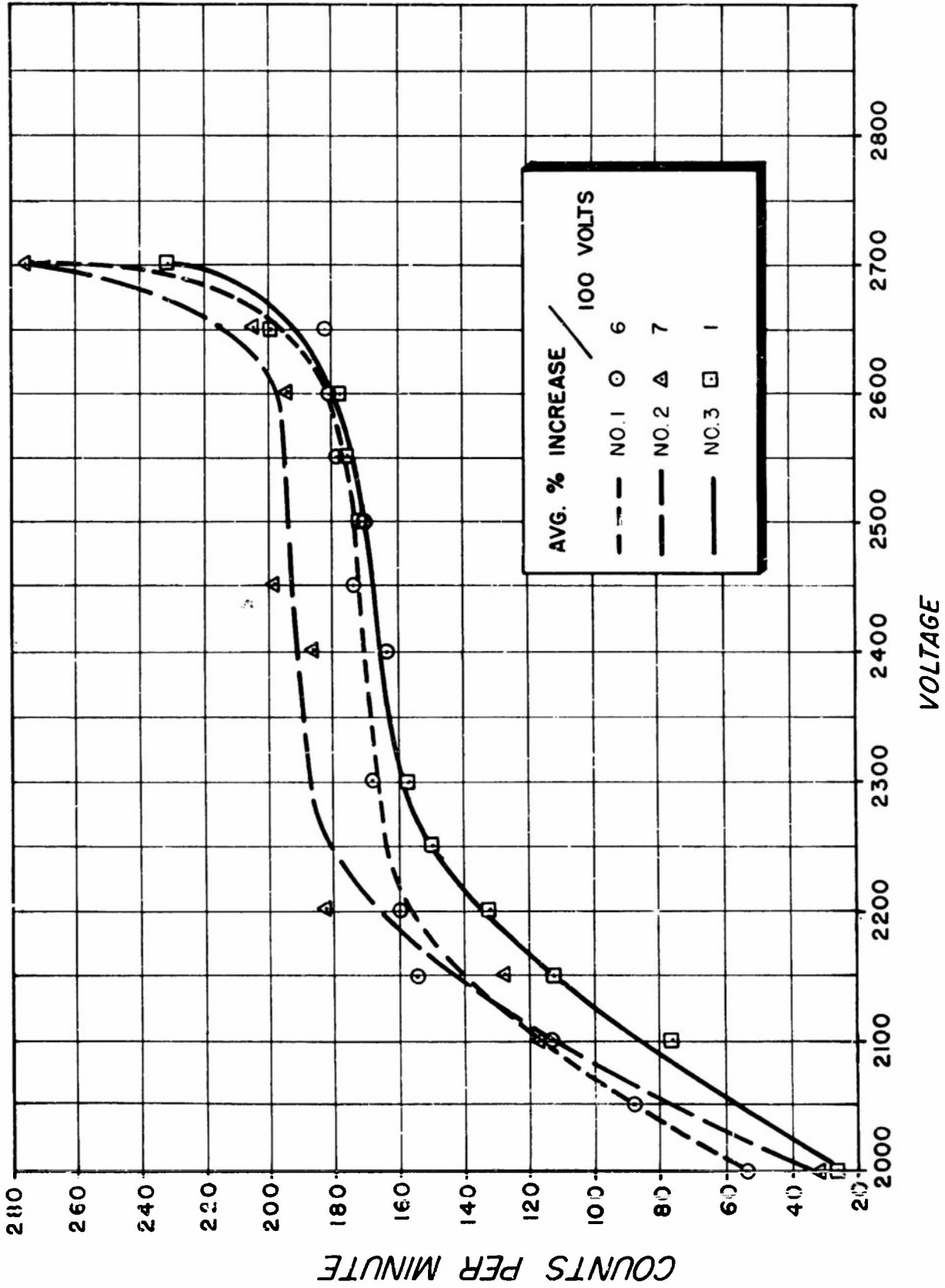

GRAPH 2-b

SECOND FILLING (BRASS CATHODES)

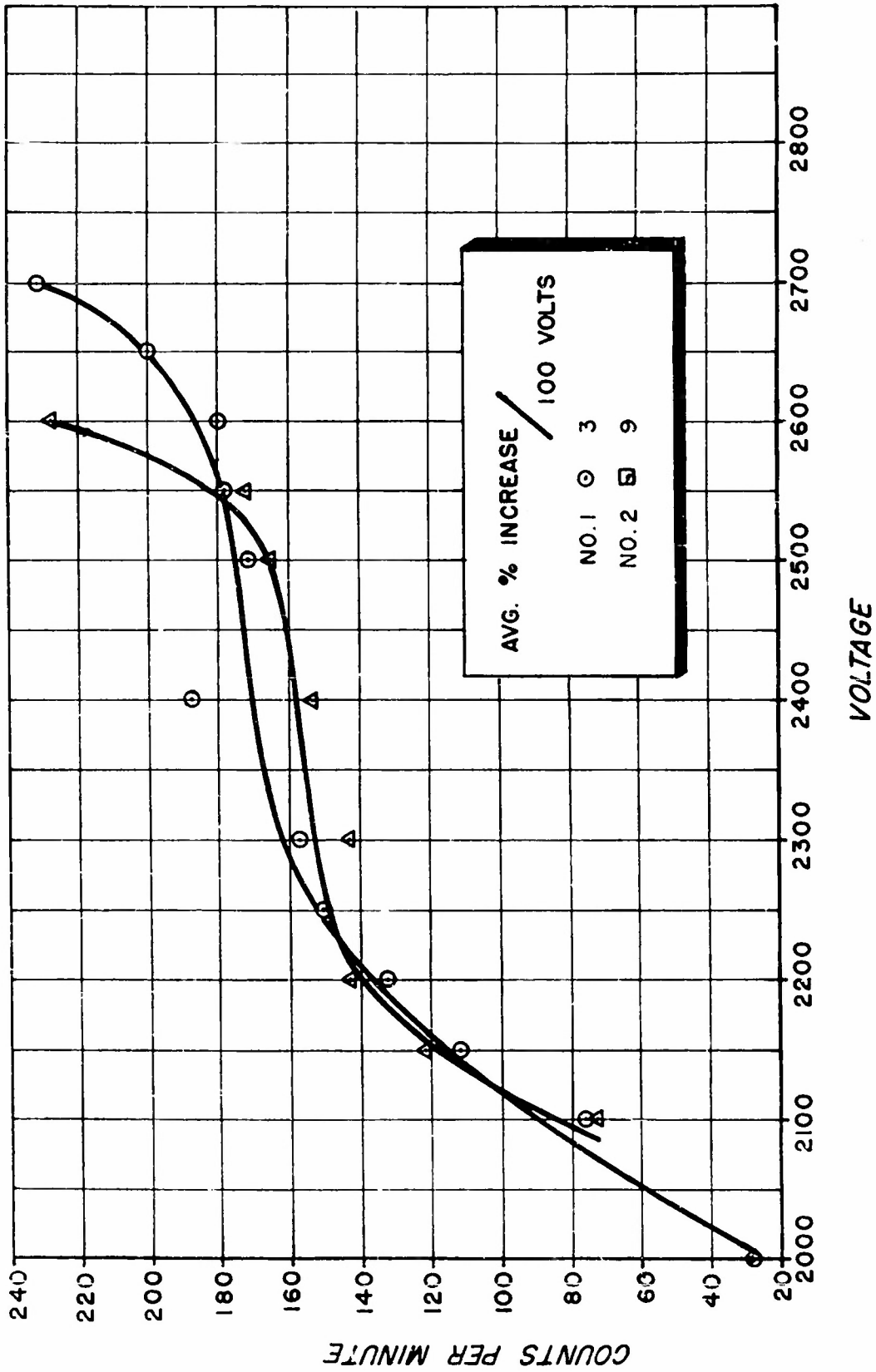

GRAPH 2-C

THIRD FILLING- (19 cm. Hg of BF_3) COPPER CATHODES

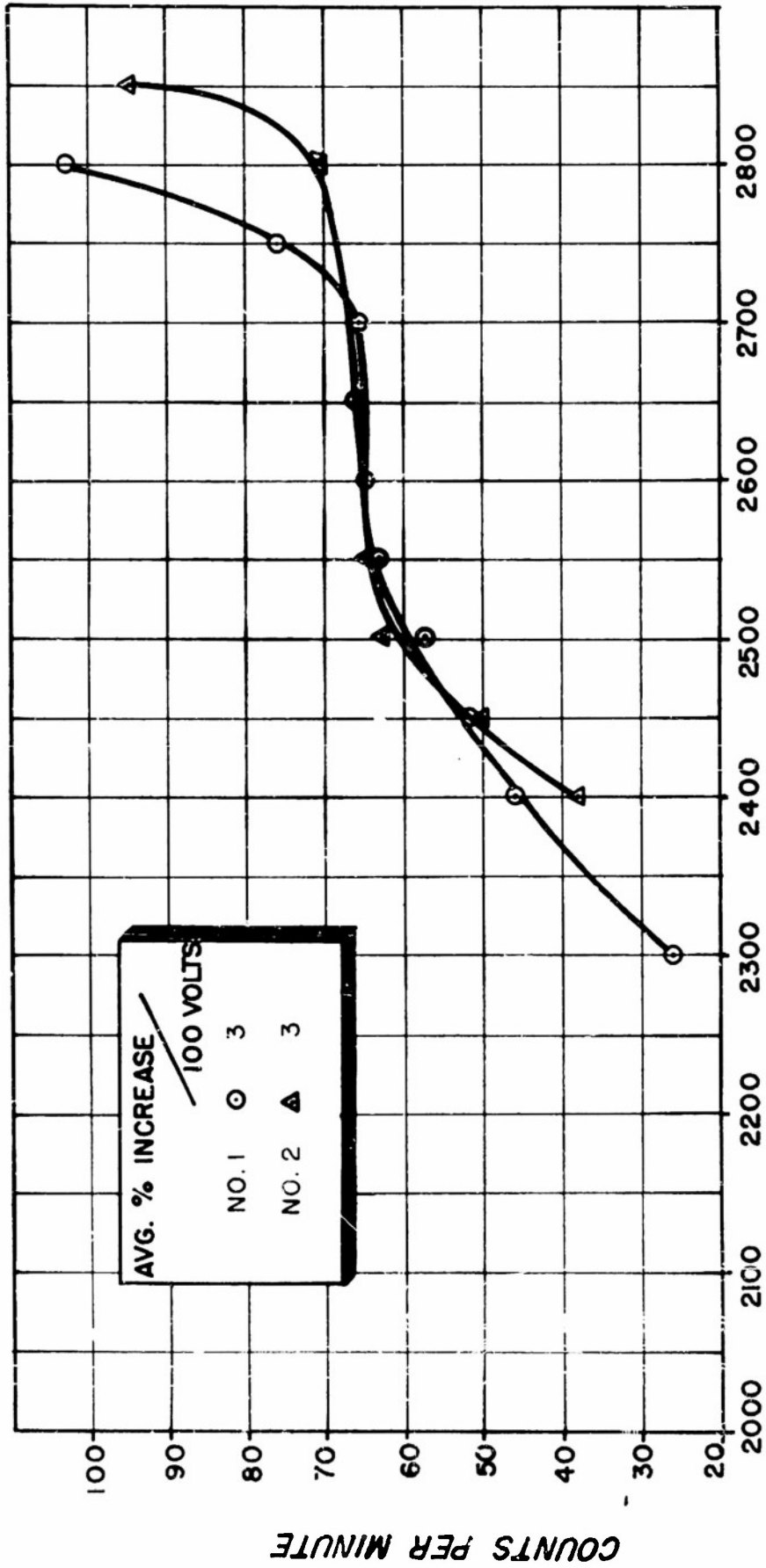

VOLTAGE

GRAPH 3 - d

THIRD FILLING (19 cm. Hg of B_5) STEEL CATHODES

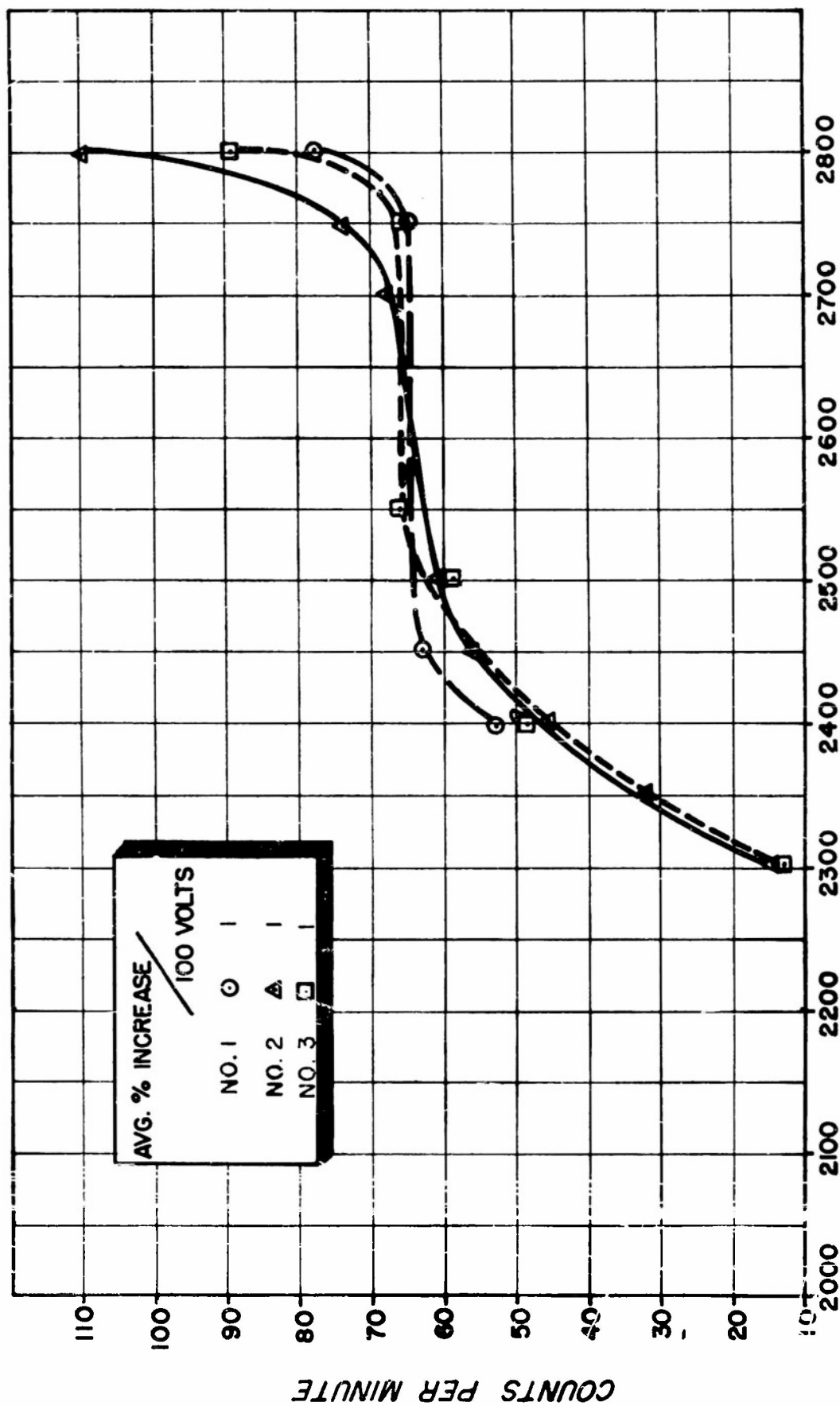

VOLTAGE

GRAPH 3 - b

THIRD FILLING (19 cm. Hg of BF₃) BRASS CATHODES

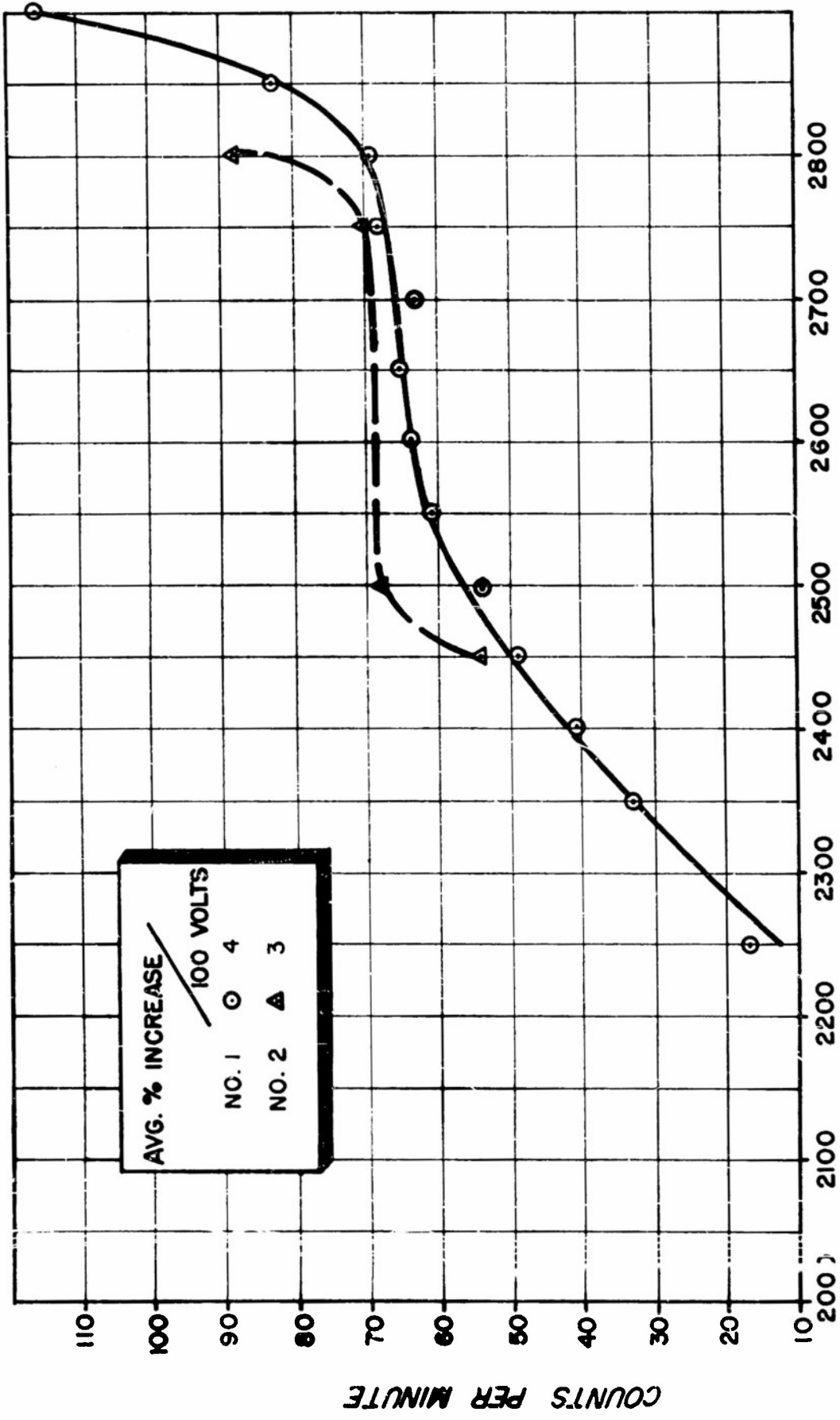

VOLTAGE

GRAPH 3-C

THIRD FILLING (19 cm. Hg of BF₃ + 1/2 cm. Hg of A) COPPER CATHODES

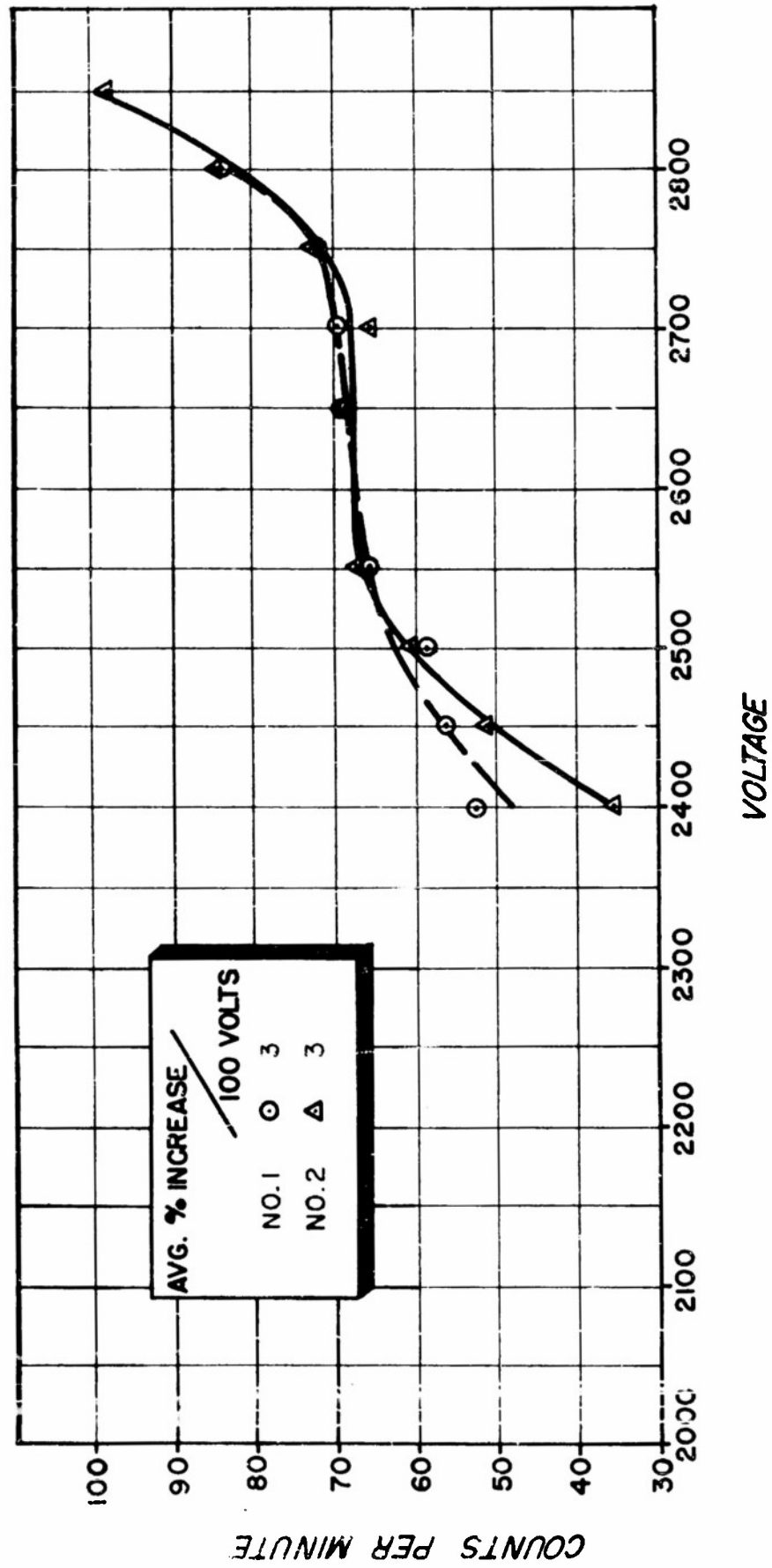

AVG. % INCREASE
 / 100 VOLTS
 NO.1 ○ 3
 NO.2 ▲ 3

GRAPH 3-d

THIRD FILLING (19 cm. Hg of $B\bar{E}_5 + \frac{1}{2}$ cm. Hg of A) STEEL CATHODES

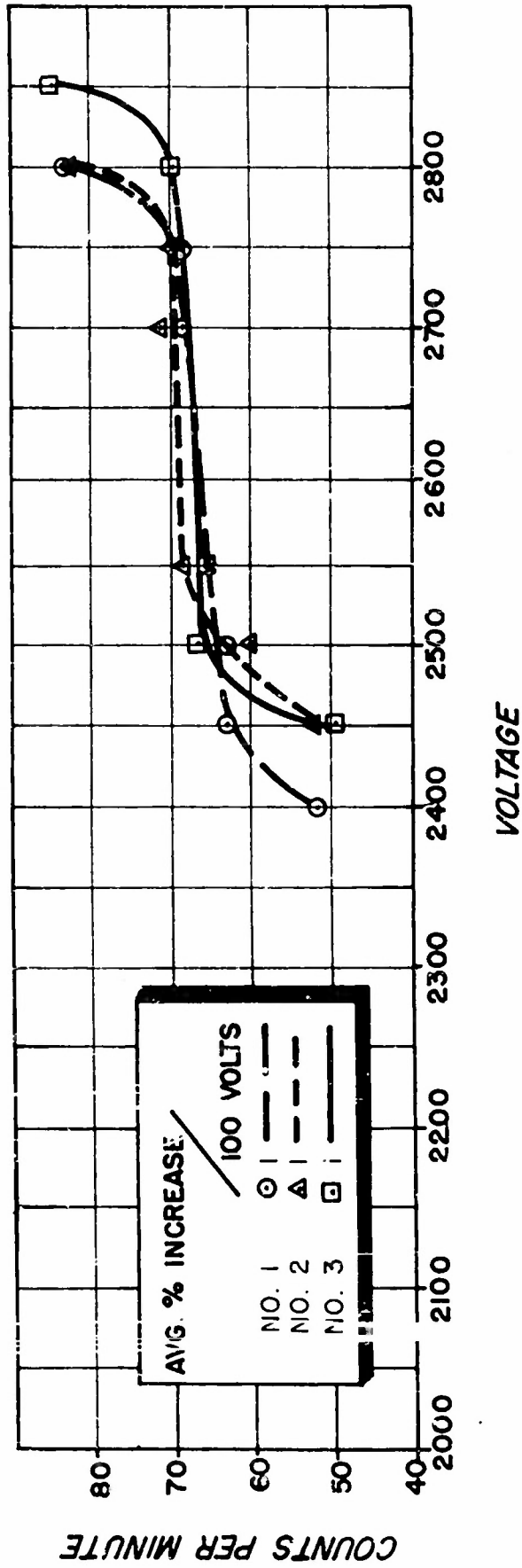

GRAPH 3-C

THIRD FILLING (19 cm. Hg of BF₅ + 1/2 cm. Hg of A) BRASS CATHODES

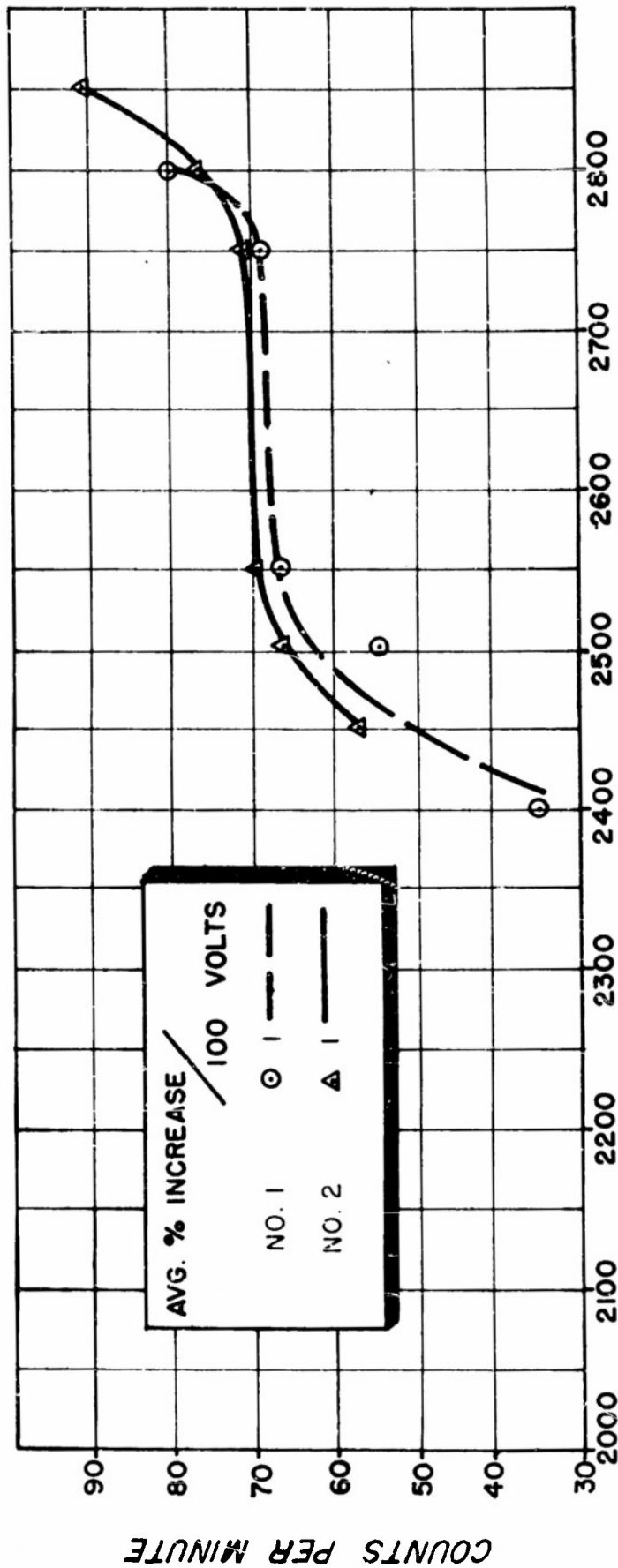

VOLTAGE

GRAPH 3-f

THIRD FILLING (19 cm. Hg of BF_3 + 2 cm. Hg of A) COPPER CATHODES

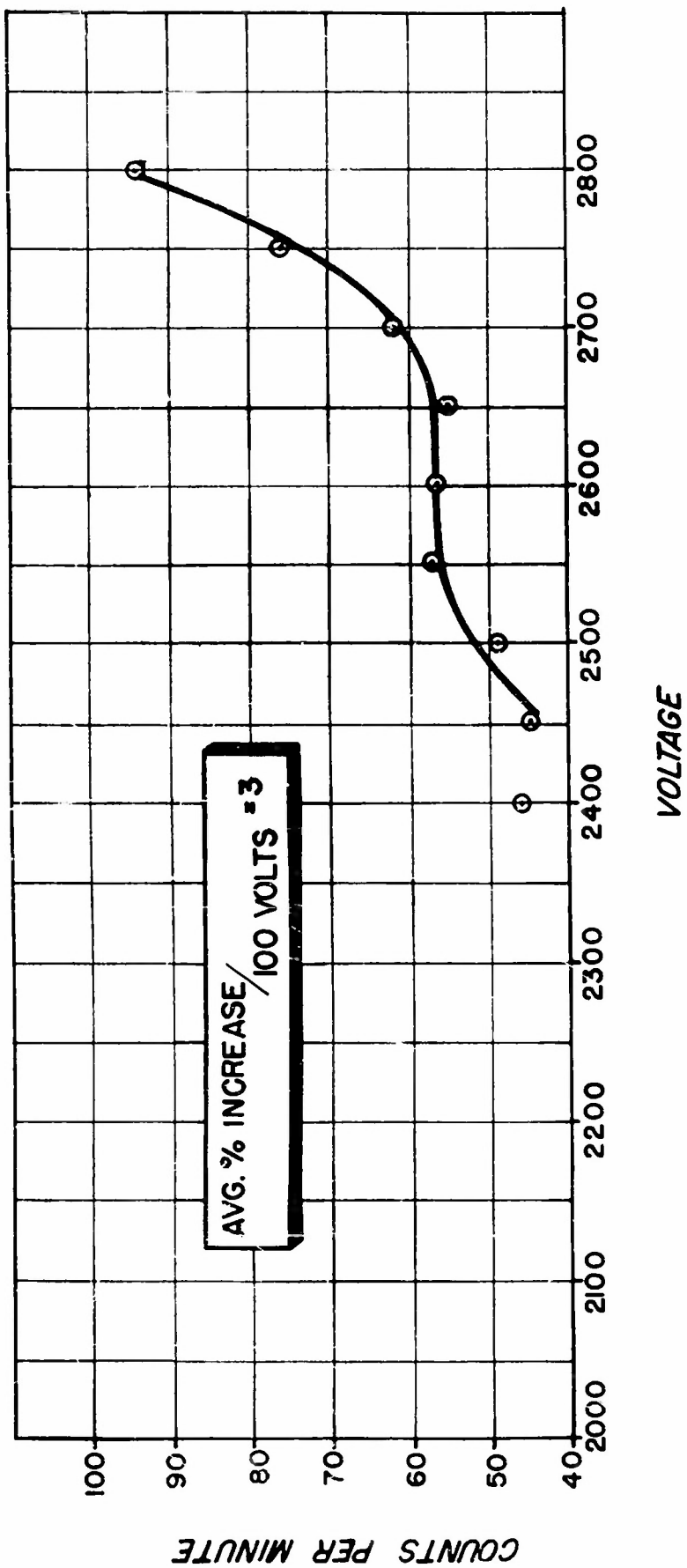

GRAPH 3-g

THIRD FILLING (19 cm. Hg of $B\bar{F}_3 + 2$ cm. Hg of A) STEEL CATHODES

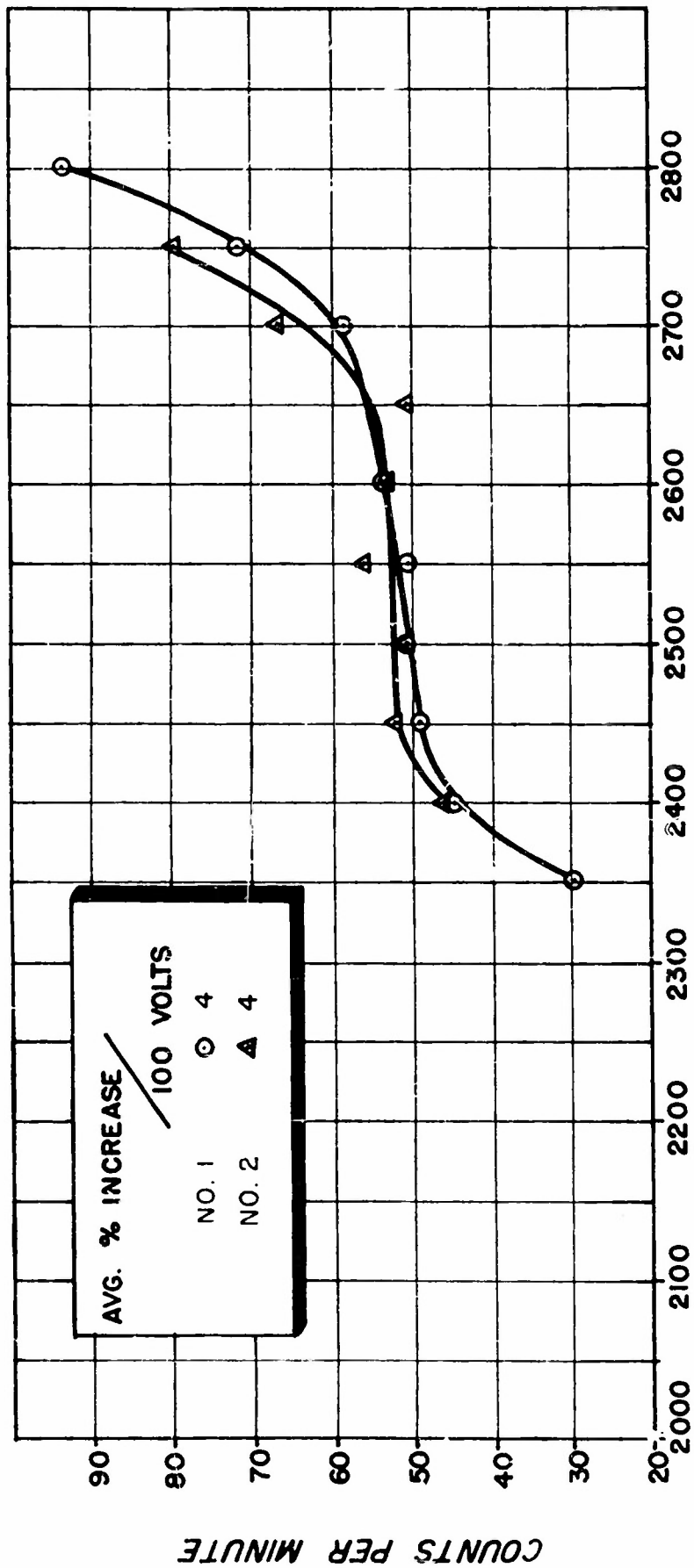

VOLTAGE

GRAPH 3-h

THIRD FILLING (19 cm. Hg of BF₃ + 2 cm. Hg of A) BRASS CATHODES

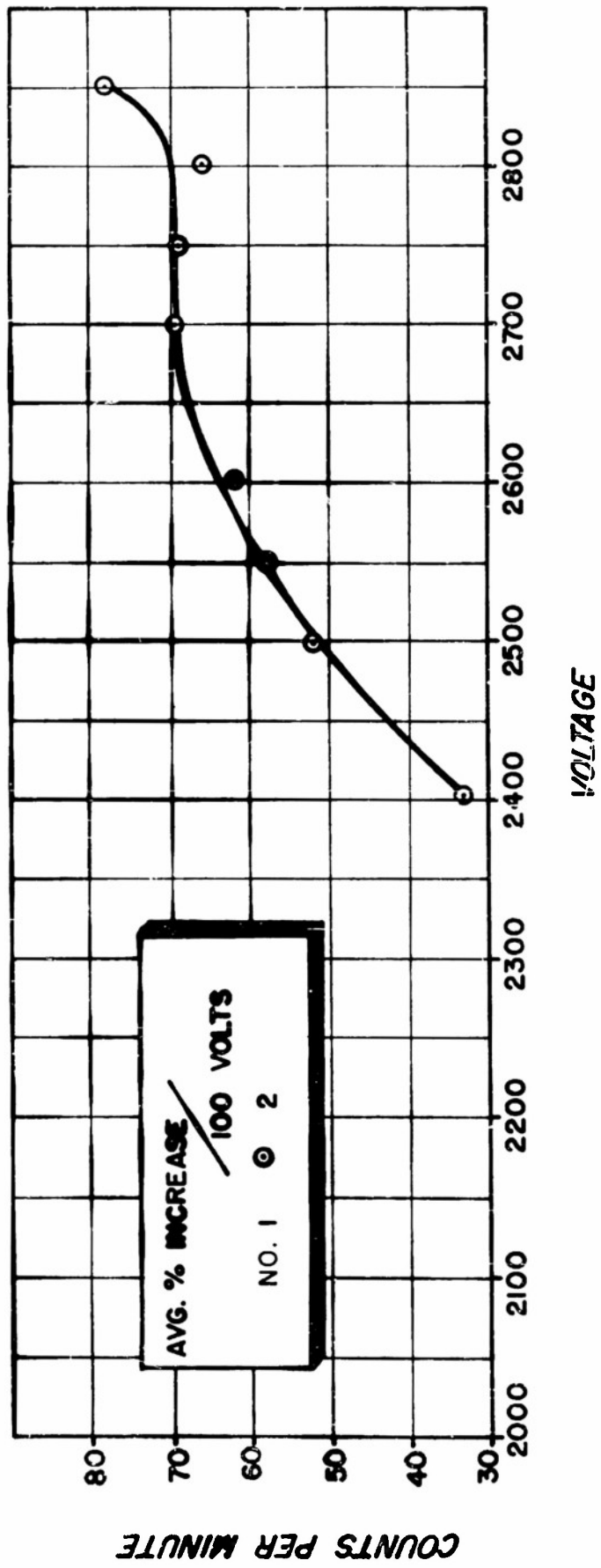

GRAPH 3-i

THIRD FILLING-COMPARISON OF COPPER CATHODE COUNTER

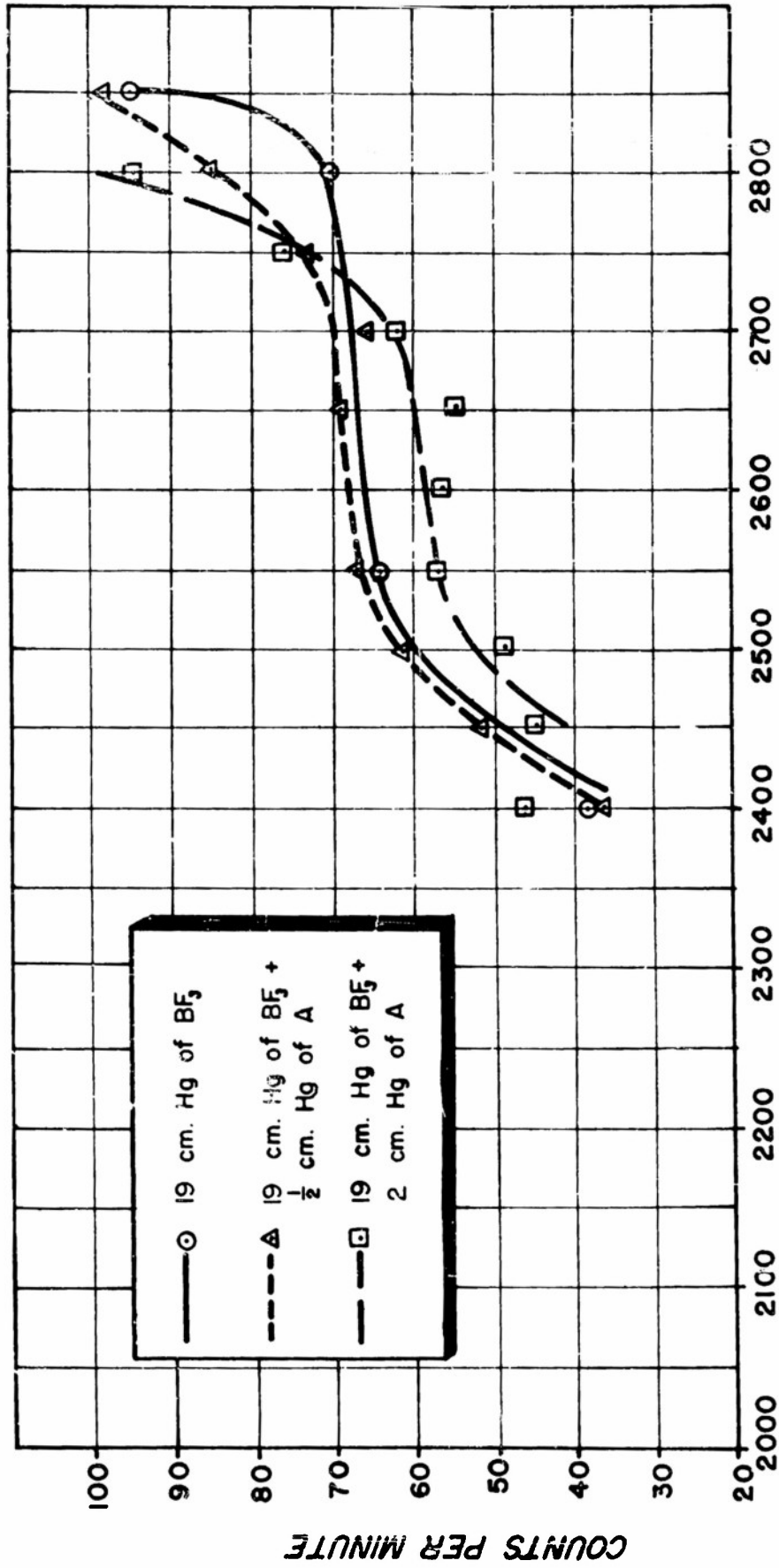

VOLTAGE

GRAPH 3-j

THIRD FILLING-COMPARISON OF STEEL CATHODE COUNTER

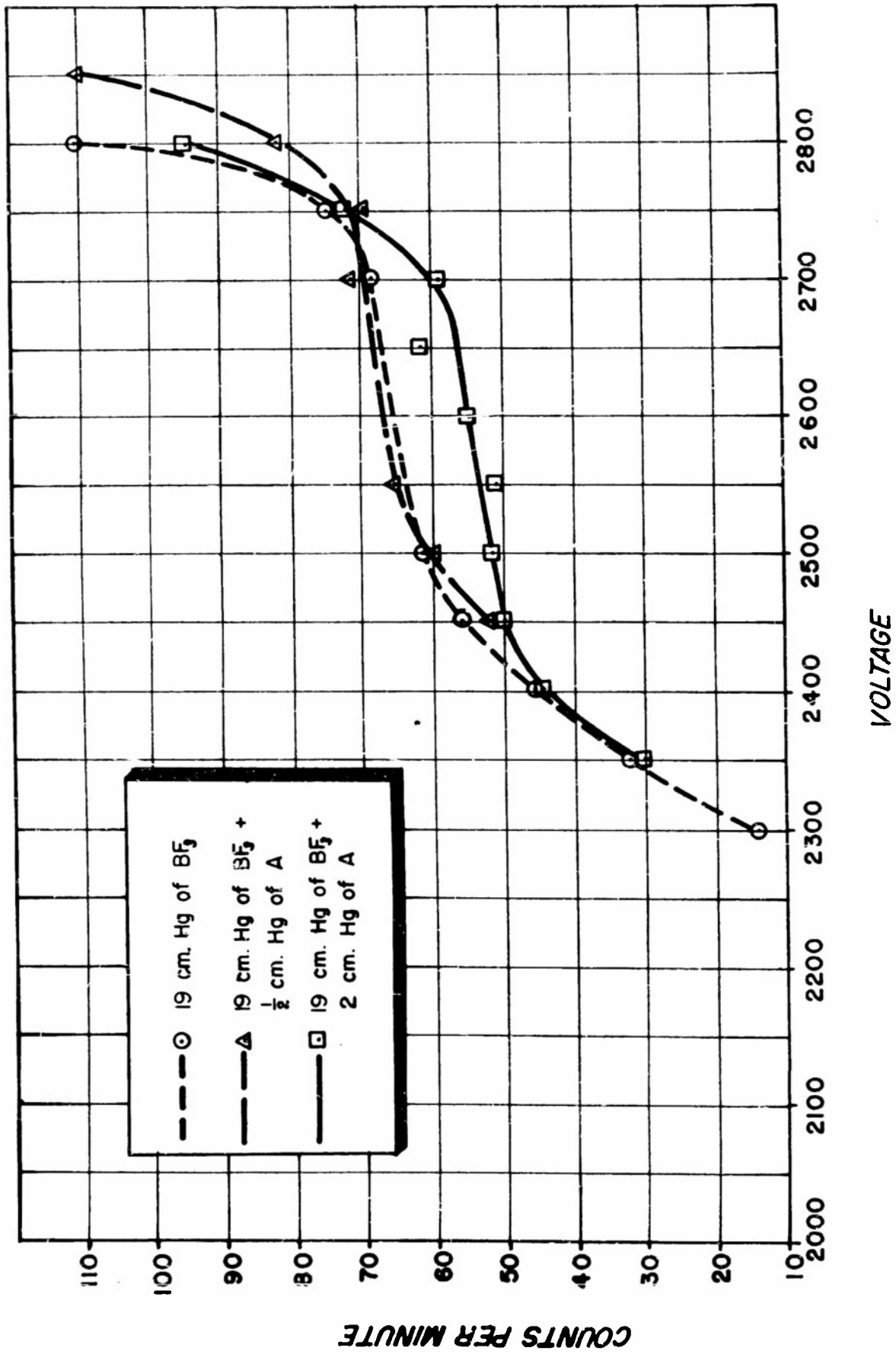

GRAPH 3-K

THIRD FILLING-COMPARISON OF BRASS CATHODE COUNTER

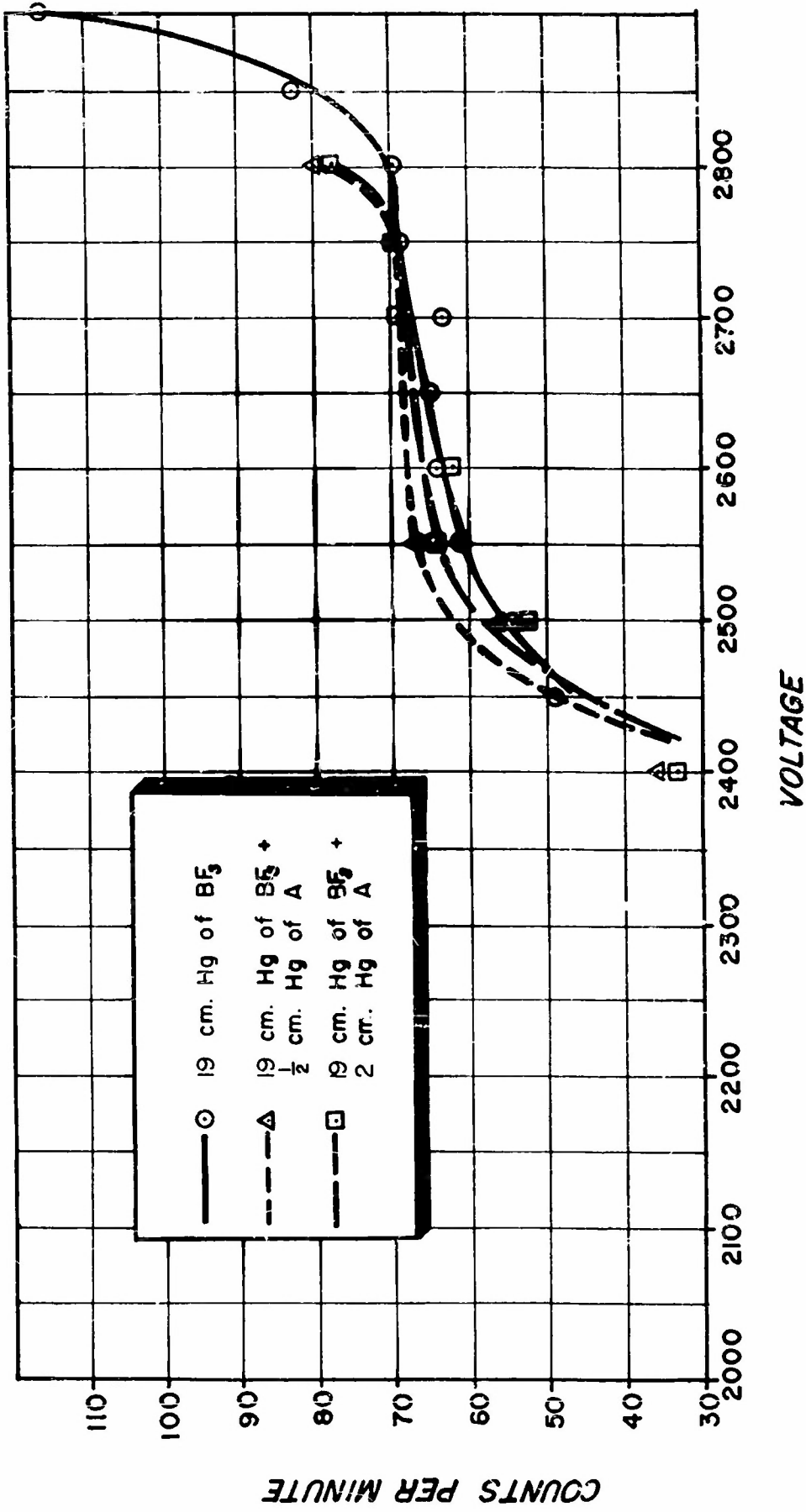

GRAPH 3-L