

Armed Services Technical Information Agency

Because of our limited supply, you are requested to return this copy **WHEN IT HAS SERVED YOUR PURPOSE** so that it may be made available to other requesters. Your cooperation will be appreciated.

AD

28951

NOTICE: WHEN GOVERNMENT OR OTHER DRAWINGS, SPECIFICATIONS OR OTHER DATA ARE USED FOR ANY PURPOSE OTHER THAN IN CONNECTION WITH A DEFINITELY RELATED GOVERNMENT PROCUREMENT OPERATION, THE U. S. GOVERNMENT THEREBY INCURS NO RESPONSIBILITY, NOR ANY OBLIGATION WHATSOEVER; AND THE FACT THAT THE GOVERNMENT MAY HAVE FORMULATED, FURNISHED, OR IN ANY WAY SUPPLIED THE SAID DRAWINGS, SPECIFICATIONS, OR OTHER DATA IS NOT TO BE REGARDED BY IMPLICATION OR OTHERWISE AS IN ANY MANNER LICENSING THE HOLDER OR ANY OTHER PERSON OR CORPORATION, OR CONVEYING ANY RIGHTS OR PERMISSION TO MANUFACTURE, USE OR SELL ANY PATENTED INVENTION THAT MAY IN ANY WAY BE RELATED THERETO.

Reproduced by
DOCUMENT SERVICE CENTER
KNOTT BUILDING, DAYTON, 2, OHIO

UNCLASSIFIED

28951

ASTIA FILE COPY

WADC TECHNICAL REPORT 54-50

A RECORDING MAGNETIC FLUXMETER

**RALPH I. BERGE, LT COL, USAF
CHARLES A. GUDERJAHN, 1st LT, USAF**

AERONAUTICAL RESEARCH LABORATORY

JANUARY 1954

WRIGHT AIR DEVELOPMENT CENTER

FOREWORD

This report was prepared by Ralph I. Berge, Lt. Colonel, USAF, and Charles A. Guderjahn, 1st Lt., USAF, and describes a "Recording Magnetic Fluxmeter" developed by the authors. The work was accomplished under RDO 477-600 "Structural Materials" with J. B. Johnson as project supervisor.

ABSTRACT

A recording fluxmeter which employs integrators has been developed for the tracing of direct current magnetization curves. The current induced in a search coil surrounding a magnetic sample causes a sensitive galvanometer to deflect. Deflection of the galvanometer is detected by a balanced photocell bridge and photocell bridge output is amplified electronically. Negative feedback is applied to the galvanometer so as to reduce galvanometer deflections. The output voltage of the amplifier is the integral of the voltage induced in the search coil and is proportional to the magnetic flux in the sample. This voltage is applied to the Y axis of an XY recorder. The response of the recorder in the X direction is controlled by the magnetization current in the case of a ring core or by another integrator when a magnetic potentiometer is used. The time constant of the fluxmeter is small and high accuracy is obtained.

PUBLICATION REVIEW

This report has been reviewed and is approved.

FOR THE COMMANDER



LESLIE B. WILLIAMS
Colonel, USAF
Chief, Aeronautical Research Laboratory
Directorate of Research

TABLE OF CONTENTS

	Page
I Introduction	1
II Principle of Operation	2
III Galvanometer and Optical System.	4
IV Amplifier.	5
V Calibration.	5
VI Operation.	6
VII Accuracy and Sensitivity	7
VIII Conclusions.	7

LIST OF FIGURES

Figure	Page
1 Integrator Circuit	8
2 Power Supply Circuit	9
3 Hysteresis Loop Being Plotted.	10
4 Simplified Circuit of Fluxmeter.	11
5 Galvanometer and Optical System.	12
6 Bottom View of Amplifier Chassis	12

I INTRODUCTION

The ballistic galvanometer is usually employed for obtaining hysteresis loops of magnetic materials. This method, however, requires considerable time and effort on the part of a skilled operator. Coiffi¹ has developed a recording fluxmeter which employs one or two integrators and a two axis recorder for tracing magnetization curves directly on standard coordinate paper. The fluxmeter described in this paper is of a somewhat similar design. The instrument, highly sensitive and accurate, allows the tracing of a hysteresis curve in a few minutes. Commercially available components are used and no time-consuming laboratory work is required in construction. The search coil wound on the sample requires only a few turns of wire because of the high sensitivity of the instrument. The circuit for the integrator and power supply are indicated in Figures 1 and 2. An Electronic Associates "Variplotter" two-axis plotting board is used to record the hysteresis loop. Figure 3 indicates a hysteresis loop being plotted.

1 Coiffi, Recording Fluxmeter of High Accuracy and Sensitivity, Rev of Sci Inst 21, 624-28 (July 50)

II PRINCIPLE OF OPERATION

The principle of operation may best be understood by reference to Figure 4. Two coils are wound on a ring sample of magnetic material. The primary is excited with slowly varying direct current. The voltage drop across r_4 is a measure of the primary current. The movement of the pen of the recorder in the X direction is proportional to the current in the primary coil and thus to the magnetizing force.

As shown in Figure 4, any change of magnetic flux in the sample will induce a voltage in the secondary search coil, causing a deflection in the galvanometer. The mirror of the galvanometer which had previously lighted two photocells equally, will then direct more light on one photocell than on the other. An error voltage is generated in the bridge circuit of which the photocells form a part. This error voltage is amplified and fed back into the galvanometer circuit through the capacitor C in such a manner as to reduce the galvanometer deflection. The output of the amplifier is the integral of the voltage induced in the secondary coil and thus is proportional to the flux in the sample. The amplifier output is also applied to the Y Axis of the recorder.

The following differential equation describes the behavior of the galvanometer coil:

$$I \frac{d^2\alpha}{dt^2} + b \frac{d\alpha}{dt} + k\alpha = ge \quad (1)$$

where α is the angular deflection of the galvanometer coil, I is the moment of inertia of the coil, $b \frac{d\alpha}{dt}$ is the total mechanical and electromagnetic damping torque, $k\alpha$ is the torque due to the suspension and ge is the torque due to the voltage e appearing across the galvanometer. The voltage e is given by:

$$e = \Theta_i - \Theta_o + A\alpha \quad (2)$$

where Θ_i is the voltage generated in the secondary by a change in flux in the sample, Θ_o is the voltage across R and $A\alpha$ is a positive feedback voltage appearing across r_2 .

If the total stray capacitance loading the photocells is small, for small deflections of the galvanometer, the output voltage of the amplifier is $K\alpha$ where K is the overall gain of the photocells and electronic amplifier. The output impedance of the amplifier is represented by r_3 .

Now if the currents are as marked in figure 4:

$$K\alpha = i' r_3 + \frac{1}{C} \int i' dt + \Theta_o \quad (3)$$

$$k\alpha = \frac{N}{R} e_0 - \frac{N}{r_1} e_0 + \frac{1}{RC} \int e_0 dt - \frac{1}{r_1 C} \int e_0 dt + e_0 \quad (4)$$

Differentiating and rearranging we get:

$$e_0 + C(R + r_1) \frac{de_0}{dt} = RCK \frac{d\alpha}{dt} + \frac{RCN}{r_1} \frac{de_0}{dt} + \frac{R}{r_1} e_0 \quad (5)$$

The voltage output of the search coil is given by:

$$e_z = N 10^{-8} \frac{d\phi}{dt} \quad (6)$$

Substituting equations (2) and (6) in (1) and rearranging we get:

$$e_0 = -\frac{I}{g} \frac{d^2k}{dt^2} - \frac{b}{g} \frac{dk}{dt} - \frac{k}{g} \alpha + N 10^{-8} \frac{d^2\phi}{dt^2} + A\alpha \quad (7)$$

Differentiation of equation (7) gives:

$$\frac{de_0}{dt} = -\frac{I}{g} \frac{d^3k}{dt^3} - \frac{b}{g} \frac{d^2k}{dt^2} - \frac{k}{g} \frac{d\alpha}{dt} + N 10^{-8} \frac{d^3\phi}{dt^3} + A \frac{d\alpha}{dt} \quad (8)$$

Substitution of (7) and (8) in (5) gives:

$$\begin{aligned} & \left[\frac{RCN}{r_1} + C(R + r_1) \right] \frac{I}{g} \frac{d^3k}{dt^3} + \left\{ \left[\frac{RCN}{r_1} + C(R + r_1) \right] \frac{b}{g} + \left(\frac{R}{r_1} + 1 \right) \frac{I}{g} \right\} \frac{d^2k}{dt^2} \\ & + \left\{ \left[\frac{RCN}{r_1} + C(R + r_1) \right] \frac{k}{g} + \left(\frac{R}{r_1} + 1 \right) \frac{b}{g} - C(R + r_1)A + RCK \right\} \frac{d\alpha}{dt} \\ & + \left\{ \left(\frac{R}{r_1} + 1 \right) \frac{k}{g} - A \right\} \alpha = N 10^{-8} \frac{d^3\phi}{dt^3} + C(R + r_1)N 10^{-8} \frac{d^2\phi}{dt^2} \quad (9) \end{aligned}$$

The measured values of the constants are $\frac{I}{g} = 1.9 \times 10^{-4}$, $\frac{b}{g} = 1.3 \times 10^{-3}$, $\frac{k}{g} = 1.4 \times 10^{-4}$, $K = 4 \times 10^4$, $r_3 = 200 \Omega$ approx., $C = 10^{-6}$ farads, $R = 12 \Omega$, $r_1 = 26 \Omega$. The amount of positive of feedback is so chosen that:

$$\left(\frac{R}{r_1} + 1 \right) \frac{k}{g} - A = 0 \quad (10)$$

With this condition fulfilled equation (9) may be integrated term by term. The resulting equation after substitution of the numerical values of the constants is:

$$6 \times 10^{-8} \frac{d^2 \phi}{dt^2} + 3 \times 10^{-4} \frac{d\phi}{dt} + 0.5\alpha = N 10^{-8} \phi + 2 \times 10^{-12} N \frac{d\phi}{dt} + L \quad (11)$$

where L is the constant of integration.

The first term in (11) is negligible and the time constant of the system is $3 \times 10^{-4} / 0.5 = 6 \times 10^{-4}$ second. The steady state solution of (11) is after rearrangement:

$$\phi = \frac{1}{N} \left\{ 10^8 \left[RC + \left(\frac{R}{F_1} + 1 \right) \frac{b}{g} \frac{K}{K} \right] K\alpha - L \right. \quad (12)$$

The amplifier output voltage $K\alpha$ is applied to the recorder. Thus the pen of the recorder moves proportionally to the amount of flux in the sample. The constant of integration, L, is of no importance since just the length of the pen trace is measured.

III GALVANOMETER AND OPTICAL SYSTEM

The arrangement of the galvanometer and optical system is shown in figure 5. When the galvanometer is at balance, light is focused equally on two closely spaced photocells of the vacuum type. No prism is used to split the light beam. Adjustment of the system balance is easily made by either turning the galvanometer suspension or by moving the photocells and amplifier chassis. In addition fine adjustment may be made by means of the galvanometer control potentiometer. The light source is a filament heated by direct current in order to avoid inducing 60 cycle hum into the system. Provision is made for two integrators. The second integrator is for use in connection with a magnetic potentiometer.

The galvanometer is a Leeds and Northrup Type 2285X with 7.1 mm/uv sensitivity, critical damping resistance of 120 ohms, period of 7.4 second and coil resistance of 26 ohms. The galvanometer was so constructed as to have a stable zero. In order to minimize thermal currents in the galvanometer circuit, all connections are made of clean copper lightly coated with grease to reduce oxidation. Also the galvanometer and other connections are thermally insulated in copper boxes packed with cotton batting. Precautions are taken to provide good electrical insulation of the galvanometer circuit to eliminate leakage currents.

The galvanometer and photocells are mounted on a specially constructed vibration-free table which in turn rests on a concrete floor. Vibration is so reduced that it has a negligible effect on the operation of the fluxmeter.

IV AMPLIFIER

The photocells and associated amplifier are mounted together on the same chassis in order to reduce lead capacitance and leakage currents. A bottom view of the amplifier chassis is shown in Figure 6.

The photocells are arranged in a bridge circuit with the output of the photocell bridge near ground potential.

The preamplifier tube, 1U4, was selected because of its low inter-electrode capacity and filament voltage. This low capacity-to-ground is desirable in order to avoid capacitative loading of the photocells. The filament current of the preamplifier tube is supplied by a battery to minimize hum and capacity-to-ground. A relay, operated by turning on the power supply, controls the filament current.

In order for the servomechanical system to have a small time constant, it is necessary that the output of the amplifier to the capacitor C have a low impedance, i.e. r_3 be small. This condition is achieved while employing miniature components by using a type 6AH6 tube operating in its high transconductance region. The range of control in the high transconductance region is extended by using a constant current load tube, also a 6AH6, and by operating the screen voltage at a constant 150 volts above the cathode.

A low leakage capacitor is used instead of a mutual inductance to oppose the interlinkages of the search coil since high quality computing type capacitors are readily available and less power output from the amplifier is required.

V CALIBRATION

The total flux in the sample at any moment is given by equation (12) or, neglecting the constant of integration,

$$\Phi = \frac{1}{N} J (K\alpha) \text{ gauss} \quad (13)$$

where $(K\alpha)$ is the output voltage of the amplifier and J is the calibration constant,

$$J = 10^8 \left[RC + \left(\frac{R}{r_1} + 1 \right) \frac{b}{gk} \right] \quad (14)$$

The last term in the calibration constant is about 0.5% of the first so a change in the gain of the amplifier will affect J only slightly. The values of b, g and K may easily be experimentally determined, and $J = 1205$.

The recorder also has a variable scale factor of G cm/volt. An external source of voltage is used to adjust G so that GJ is some convenient number adapted to the scale of the graph paper used. Then

$$\phi = \frac{1}{N} GJ (H) \text{ (length of trace on paper)} \quad (15)$$

The H axis of the recorder is calibrated in a similar manner.

VI OPERATION

A definite procedure must be followed in order to properly balance and operate the fluxmeter. The fluxmeter has to be balanced before operation because of both changes in thermal currents and aging of the photocells from day to day. The galvanometer and optical system must be adjusted so that the amplifier output voltage is zero without either positive or negative feedback. Coarse adjustment is made by either turning the galvanometer suspension or by moving the photocell chassis while the output drift meter is at low sensitivity. The galvanometer control potentiometer is then adjusted so that the output drift meter reads an average of zero at high sensitivity.

The intensity of the galvanometer light is first decreased and then the negative feedback switch is closed. Otherwise, a high transient current will flow at the instant the switch is closed, permanently altering the galvanometer suspension. It is necessary to return the galvanometer light to the same intensity as when balancing the system to preserve the original balance.

The positive feedback potentiometer is adjusted by displacing the galvanometer to either side of zero using the displacement switches, and then adjusting the positive feedback potentiometer so that there is a minimum of galvanometer drift as indicated on the output drift meter. A bucking battery opposes the amplifier output voltage so that the output drift meter may be read at full sensitivity while the positive feedback potentiometer is being adjusted. The amount of positive feedback required may be different for displacements on opposite sides of zero because of possible mismatching of photocells. An average of the positive feedback potentiometer settings on either side of zero is set on the potentiometer. The amount of positive feedback required usually remains constant for some time. Considerable galvanometer drift will result if there is a large difference in the amount of positive feedback required when the galvanometer is displaced on either side of zero. In this case, to minimize drift, one of the photocells should be shaded or both replaced by a more evenly matched

pair. If the system goes into oscillation, as may be ascertained by viewing the output of the amplifier on an oscilloscope, the positive feedback potentiometer is not properly adjusted.

The recorder is then calibrated and the hysteresis curve is traced so slowly that a further decrease in speed of tracing does not affect the shape of the curve. Small discontinuities may appear in the recorded hysteresis loop due to rough control of the magnetizing current. A satisfactory source of current is an autotransformer used with a full wave rectifier and several stages of filtering.

Before switching off the fluxmeter, the negative feedback switch is opened to prevent a heavy transient current from flowing in the galvanometer suspension at the moment of switching.

VII ACCURACY AND SENSITIVITY

The degree of accuracy of the fluxmeter depends on the accuracies of the calibration constant, the external calibration voltage and the recorder. In addition, the slow drift of the system due to changing thermal currents etc. must be considered.

The value of the calibration constant may be obtained within 0.3% and the calibration voltage source within 0.1%. The static error of the recorder is given as 0.1% of full scale. By carefully balancing the fluxmeter, the drift can be restricted to less than ± 25 flux interlinkages/minute. The overall error is then 0.5% ± 25 flux interlinkages/minute.

The sensitivity of the system is easily controlled by adjusting the gain of the recorder. This sensitivity may be increased to such a high degree that the drift error, normally negligible, becomes an objectionable part of the total flux change.

VIII CONCLUSIONS

The recording fluxmeter described has indicated a high degree of accuracy and sensitivity allowing hysteresis loops to be traced in the order of a few minutes. Another advantage is that the components required for construction are comparatively inexpensive and simple in design.

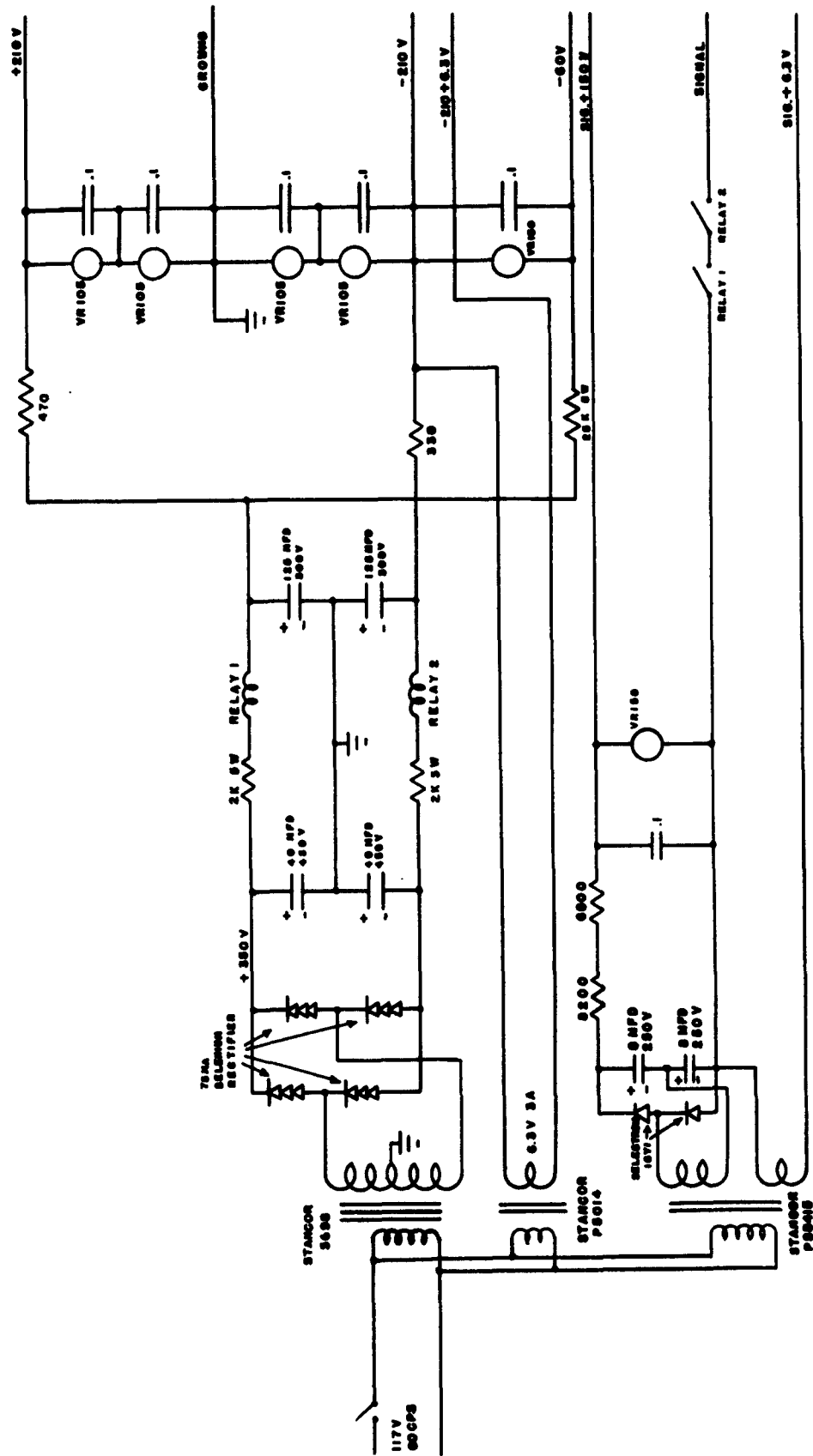

FIGURE 2 POWER SUPPLY CIRCUIT

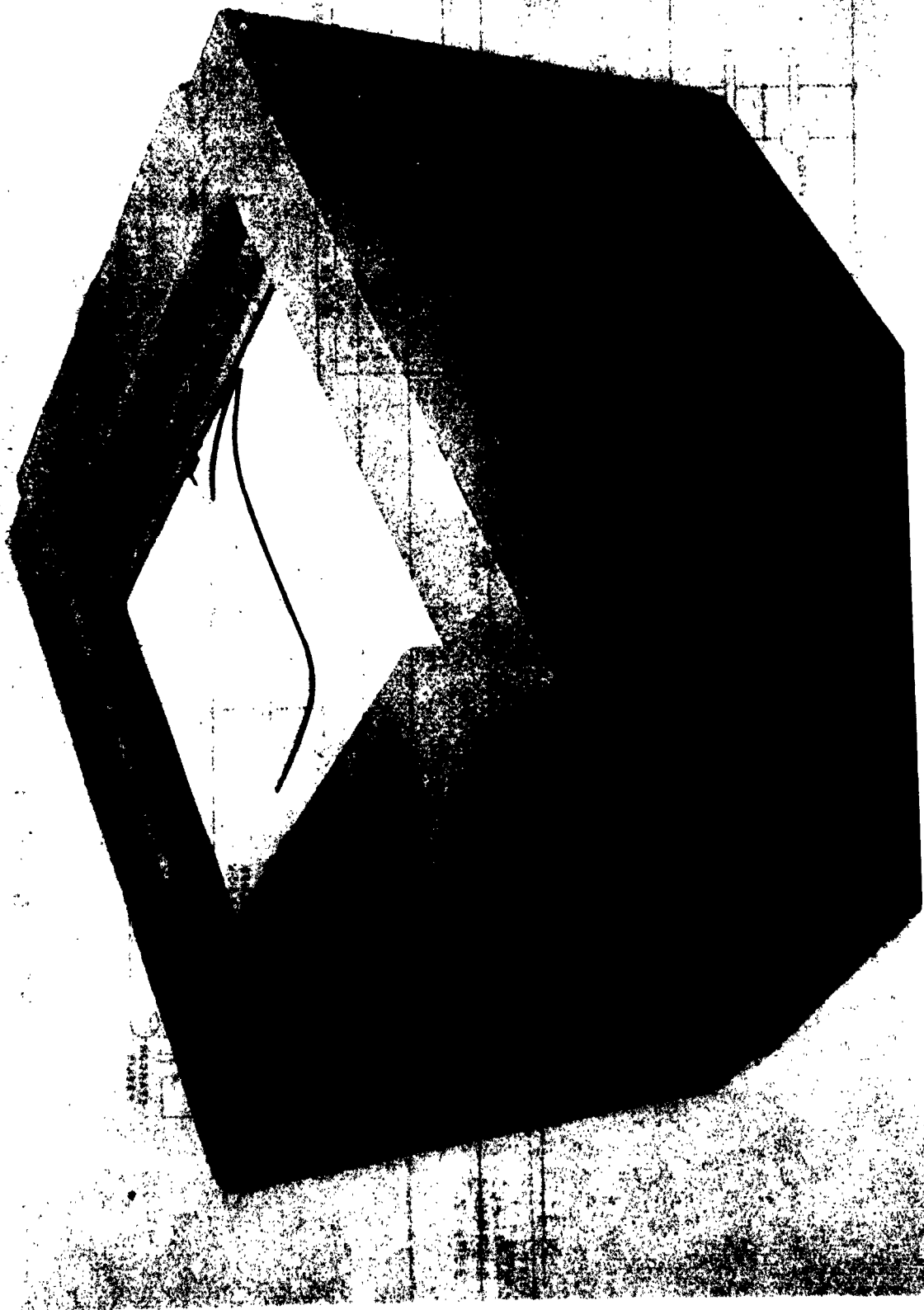

Figure 3 Hysteresis Loop Being Plotted

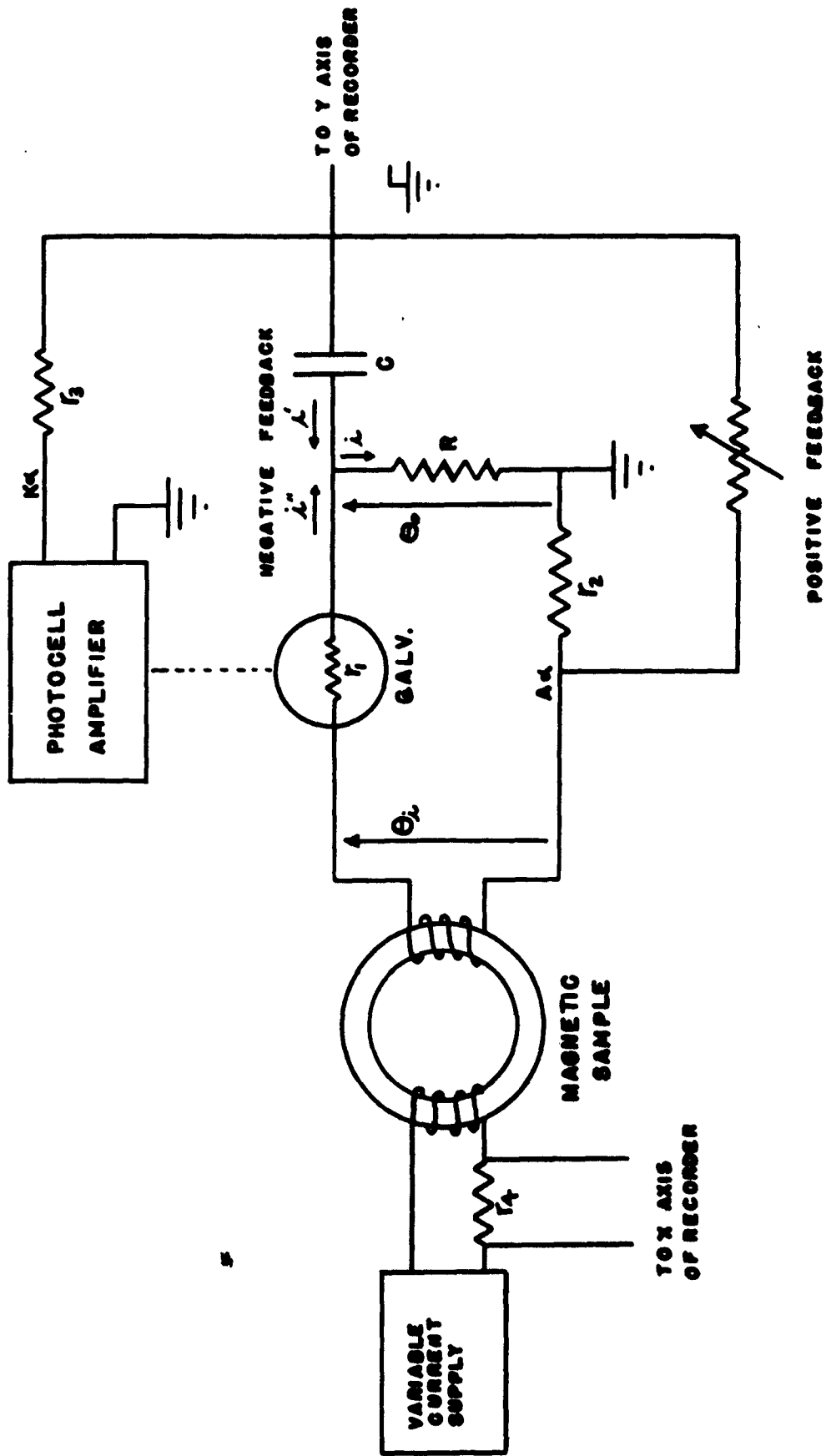

FIGURE 4 SIMPLIFIED CIRCUIT OF FLUXMETER

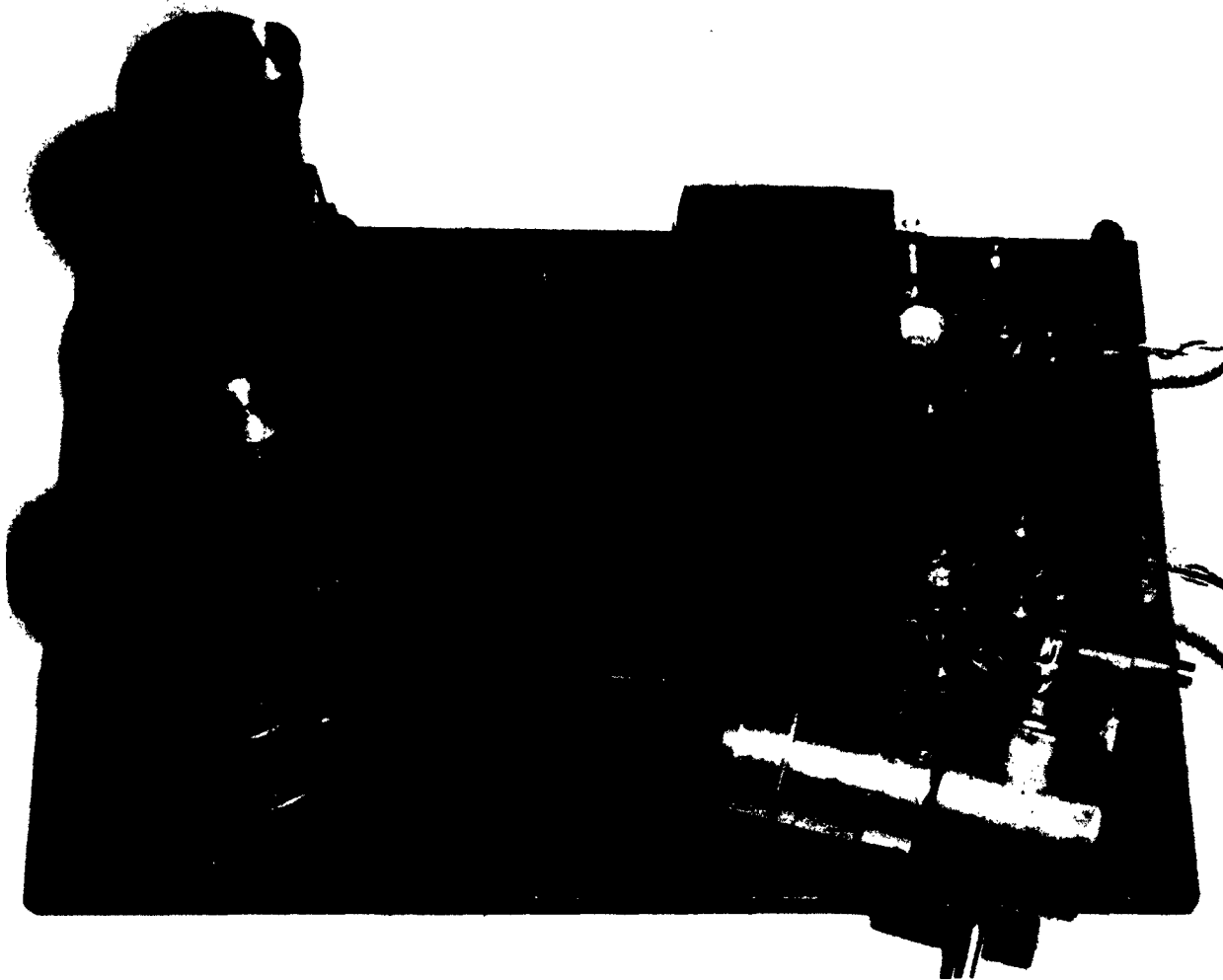

Figure 5 Galvanometer and Optical System

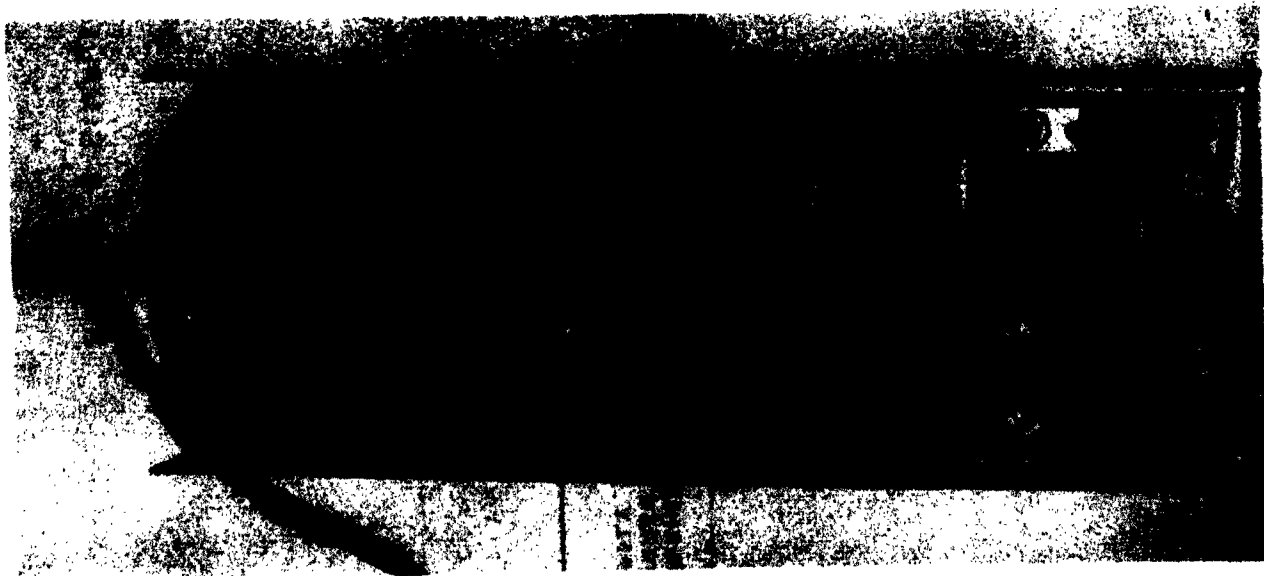

Figure 6 Bottom View of Amplifier Chassis