

UNCLASSIFIED

AD NUMBER	
AD028968	
CLASSIFICATION CHANGES	
TO:	unclassified
FROM:	confidential
LIMITATION CHANGES	
TO:	Approved for public release, distribution unlimited
FROM:	Distribution authorized to U.S. Gov't. agencies and their contractors; Administrative/Operational Use; 30 MAR 1954. Other requests shall be referred to National Aeronautics and Space Administration, Washington, DC.
AUTHORITY	
NASA TR Server Website; NASA TR Server Website	

THIS PAGE IS UNCLASSIFIED

Armed Services Technical Information Agency

Because of our limited supply, you are requested to return this copy WHEN IT HAS SERVED YOUR PURPOSE so that it may be made available to other requesters. Your cooperation will be appreciated.

AD

28968

NOTICE: WHEN GOVERNMENT OR OTHER DRAWINGS, SPECIFICATIONS OR OTHER DATA ARE USED FOR ANY PURPOSE OTHER THAN IN CONNECTION WITH A DEFINITELY RELATED GOVERNMENT PROCUREMENT OPERATION, THE U. S. GOVERNMENT THEREBY INCURS NO RESPONSIBILITY, NOR ANY OBLIGATION WHATSOEVER; AND THE FACT THAT THE GOVERNMENT MAY HAVE FORMULATED, FURNISHED, OR IN ANY WAY SUPPLIED THE SAID DRAWINGS, SPECIFICATIONS, OR OTHER DATA IS NOT TO BE REGARDED BY IMPLICATION OR OTHERWISE AS IN ANY MANNER LICENSING THE HOLDER OR ANY OTHER PERSON OR CORPORATION, OR CONVEYING ANY RIGHTS OR PERMISSION TO MANUFACTURE, USE OR SELL ANY PATENTED INVENTION THAT MAY IN ANY WAY BE RELATED THERETO.

**Reproduced by
DOCUMENT SERVICE CENTER
KNOTT BUILDING, DAYTON, 2, OHIO**

CONFIDENTIAL

**NOTICE: THIS DOCUMENT CONTAINS INFORMATION AFFECTING THE
NATIONAL DEFENSE OF THE UNITED STATES WITHIN THE MEANING
OF THE ESPIONAGE LAWS, TITLE 18, U.S.C., SECTIONS 793 and 794
THE TRANSMISSION OR THE REVELATION OF ITS CONTENTS IN
ANY MANNER TO AN UNAUTHORIZED PERSON IS PROHIBITED BY LAW.**

Reproduced

FROM LOW CONTRAST COPY.

CONFIDENTIAL

Copy 13
RM A54B18a

NACA RM A54B18a

898 808
288 968

ASTIA FILE COPY



RESEARCH MEMORANDUM

INVESTIGATION OF A THREE-BLADE PROPELLER IN COMBINATION

WITH TWO DIFFERENT SPINNERS AND AN NACA D-TYPE

COWL AT MACH NUMBERS UP TO 0.80

By George C. Kenyon and Robert M. Reynolds

Ames Aeronautical Laboratory
Moffett Field, Calif.

ADVANCE COPY
TRANSMITTED ON MAR 30 1954

CLASSIFIED DOCUMENT

This material contains information affecting the National Defense of the United States within the meaning of the espionage laws, Title 18, U.S.C., Secs. 793 and 794, the transmission or revelation of which in any manner to an unauthorized person is prohibited by law.

NATIONAL ADVISORY COMMITTEE
FOR AERONAUTICS
WASHINGTON

CONFIDENTIAL

74 B-545

200 13

100-10000

NATIONAL ADVISORY COMMITTEE FOR AERONAUTICS

RESEARCH MEMORANDUM

INVESTIGATION OF A THREE-BLADE PROPELLER IN COMBINATION

WITH TWO DIFFERENT SPINNERS AND AN NACA D-TYPE

COWL AT MACH NUMBERS UP TO 0.80

By George C. Kenyon and Robert M. Reynolds

SUMMARY

An investigation has been made to determine the aerodynamic characteristics of a three-blade propeller designed to operate ahead of a D-type cowl. The propeller (designated NACA 3.638-(675)(057)-0572) in combination with two different spinner shapes and an NACA 1-62.8-070 D-type cowl was investigated at Mach numbers up to 0.80. The characteristics of the isolated propeller-spinner combination operating at positive thrust, negative thrust, and at near static conditions were also determined. Included are results of air-stream surveys of the local velocities in the plane of the propeller. All tests were made with the model at an angle of attack of 0° and at a Reynolds number of 1,000,000 per foot, based on free-stream conditions.

The efficiency of the propeller in the presence of the cowl was higher at all Mach numbers than that of the isolated propeller-spinner combination. At design cruise conditions ($M = 0.60$, $\beta = 53^\circ$), the efficiency of the propeller with the 1-series spinner and cowl was 80 percent, as compared with 72 percent for the isolated propeller-spinner combination. The onset of marked compressibility losses was delayed from a Mach number of 0.50 to a Mach number of 0.60 by the addition of the cowl.

The effects of inlet velocity ratio and spinner shape on the propeller characteristics were not large except at the higher Mach numbers (0.70 and 0.80).

INTRODUCTION

Considerable research has been conducted on propeller-spinner-cowling combinations suitable for use with large turbine engines (refs. 1 to 5). To augment this research, an investigation was conducted in the Ames

CONFIDENTIAL

440 19325

12-foot pressure wind tunnel to determine the characteristics of a three-blade propeller and a D-type cowl with both an NACA 1-series spinner and a more nearly conical spinner. The pressure-recovery characteristics of these propeller-spinner-cowling combinations have been reported in reference 6. Reference 7 has presented some preliminary results for the propeller with the cowl and spinners.

Presented herein are results of force tests, obtained concurrently with the data presented in reference 6, for the propeller operating in the presence of the cowl with the two different spinners. Also presented are force-test results for the isolated propeller-spinner combination operating at positive thrust, negative thrust, and at near static conditions. The velocity distributions in the plane of the propeller are included.

The tests were conducted for a range of blade angles from -20° to 63° and at Mach numbers up to 0.80. All tests were made with the model at an angle of attack of 0° and at a Reynolds number of 1,000,000 per foot, based on free-stream conditions.

NOTATION

a	speed of sound
b	blade width
C_p	power coefficient, $\frac{P}{\rho n^3 D^5}$
C_T	thrust coefficient, $\frac{T}{\rho n^2 D^4}$
c_{l_d}	blade-section design lift coefficient
D	propeller diameter
HP	horsepower
h	maximum thickness of blade section
J	advance ratio, $\frac{V_0}{nD}$
M	Mach number, $\frac{V}{a}$
M_t	tip Mach number, $M \sqrt{1 + \left(\frac{\pi}{J}\right)^2}$

CONFIDENTIAL

n	propeller rotational speed
P	power
R	propeller-tip radius
r	blade-section radius
S	propeller disc area
T	thrust
T_c	thrust coefficient, $\frac{T}{\rho V^2 D^2}$
U	local velocity in the plane of the propeller
V	air-stream velocity
V_o	equivalent free-air velocity
$\frac{V_1}{V}$	inlet velocity ratio
β	propeller blade angle at 0.75 R
β_d	design propeller-section blade angle
η	efficiency, $\frac{C_T}{C_P} J$
ρ	air density

Subscripts

1	location of rake in cowl inlet
a	apparent (applied to propeller characteristics when operating ahead of the cowl)

MODEL AND APPARATUS

This investigation was conducted in the Ames 12-foot pressure wind tunnel with the model mounted on the 1000-horsepower dynamometer (described in ref. 8). A photograph of the model is presented in figure 1 and a sketch of the general model arrangement is given in figure 2. The propeller used was a three-blade type designed by Hamilton Standard Division and

it corresponded to the designation NACA 3.638-(675)(057)-0572. Blade-form curves for the propeller are shown in figure 3. Additional details of the model and its instrumentation as well as information on the full-scale design conditions can be found in reference 6.

Figure 4 is a photograph of the survey rake used to determine the velocity distribution in the plane of the propeller. The rake consisted of 24 static pressure tubes located at the radial stations listed in table I.

TESTS AND REDUCTION OF DATA

Thrust, torque, and rotational speed were measured (as described in refs. 2 and 8) for the propeller-spinner-cowl combinations and the isolated propeller-spinner combination (1-series spinner) for a range of blade angles from 33° to 63° at Mach numbers from 0.20 to 0.80. Data for the isolated propeller-spinner combination were obtained at negative thrust conditions at the same Mach numbers and blade angles and, in addition, data were obtained for this combination at a Mach number of 0.15 for blade angles from -20° to 25° . The characteristics of the isolated propeller-spinner combination were also measured at near static conditions for a blade-angle range from 10° to 25° .

Surveys of the air-stream velocity in the plane of the propeller were made at Mach numbers from 0.15 to 0.80. With the cowl installed, the effect of inlet velocity ratio on the local velocity in the propeller plane was also determined.

The Mach number used in this report was the average Mach number over the disc area as determined by velocity surveys reported in reference 8. For the tests made with the cowl installed, this Mach number (and the corresponding dynamic pressure) was corrected for blockage of the cowl by the method of reference 9. In no case did this correction exceed 1 percent.

The air-stream velocity (and, consequently, propeller advance ratio and efficiency) was corrected for the wind-tunnel-wall constraint on the propeller slipstream by the method of reference 10. Figure 5 presents a comparison of this correction with that determined experimentally by the method of reference 11 from measurements of wall pressures. The data included herein are for advance ratios at which the thrust-coefficient parameter $T_c/(1 - M^2)$ was greater than -0.5.

Analysis of the accuracy of the separate measurements of thrust, torque, and air-stream velocity, as in reference 8, indicates that errors in the propeller efficiencies reported herein are probably less than 2 percent.

RESULTS

The distribution of velocity across the propeller disc is listed in table I. These data are plotted in figure 6 for a few typical Mach numbers and inlet velocity ratios.

The characteristics of the propeller operating in the presence of the cowl are presented in figures 7 and 8 and the characteristics of the isolated propeller-spinner combination for conditions of positive thrust are presented in figure 9. The variation of maximum propeller efficiency with Mach number is summarized in figure 10 and the effect of inlet velocity ratio on the propeller characteristics is shown in figure 11.

The negative-thrust characteristics of the propeller-spinner combination are presented in figures 12 through 15 and the characteristics of the propeller-spinner combination at near static conditions are shown in figure 16 and are summarized in figure 17.

DISCUSSION

Propeller Characteristics at Positive Thrust

As in reference 2, the characteristics of the propeller operating in the presence of the cowl are presented as apparent values (figs. 7 and 8) since the determination of the propulsive thrust of the propeller was precluded by the fact that it was impractical, with the dynamometer arrangement used in the present investigation, to measure the increase in drag of the cowl and dynamometer parts within the influence of the propeller slipstream. The addition of the cowl behind the propeller resulted in reduced velocities throughout the propeller flow field, as evidenced by a comparison of figures 6(a) and 6(b) with figure 6(c). As a consequence of these reduced velocities (and in accord with the discussion of ref. 12), the thrust and power for the propeller operating ahead of the cowl were greater than that for the isolated propeller-spinner combination (at the same advance ratio), as can be seen from a comparison of figures 7 and 8 with figure 9.

Maximum efficiency.- As shown in figure 10, the efficiency of the propeller in the presence of the cowl was higher at all Mach numbers than that of the isolated propeller-spinner combination. At design cruise conditions ($M = 0.60$, $\beta = 53^\circ$), the efficiency of the propeller with the 1-series spinner and cowl was 80 percent, as compared with 72 percent for the isolated propeller-spinner combination. It may be noted here that the higher efficiencies for the propeller with the cowl were due not only to interference effects but partly to the fact that, in the presence of

the cowl, the propeller was operating more nearly in the flow field for which it was designed.

The onset of marked compressibility losses was delayed (also as a consequence of the interference effects) from a Mach number of 0.50 to a Mach number of 0.60 by the addition of the cowl (fig. 10). The large losses in efficiency at Mach numbers from 0.60 to 0.80 were due not only to the effects of compressibility but also to the fact that at blade angles of 58.5° and 63° the inner portions of the blades were probably operating at negative thrust, since the local blade angles for this portion of the blade were greater than 90° (up to 98° for $\beta = 63^\circ$). Operation of the propeller at lower blade angles at these Mach numbers (requiring higher rotational speeds) might have resulted in higher efficiencies but was not permissible because of structural limitations of the model propeller.

Effect of inlet velocity ratio.- Although the air-stream surveys (tables I(a) and I(b), and figs. 6(a) and 6(b)) show that decreasing inlet velocity ratio resulted in reduced local velocities at the propeller plane, the changes were small in comparison with the reduction in velocity occasioned by the addition of the cowl to the spinner (fig. 6(a) compared with fig. 6(c)). Consequently, as shown in figures 7, 8, and 11, the effect of inlet velocity ratio on the propeller characteristics was not large except at the higher Mach numbers (0.70 and 0.80), where small changes in local velocity resulted in relatively large changes in the propeller characteristics due to the effects of compressibility.

Effect of spinner shape.- Although the data of figures 6(a) and 6(b) indicate only small differences in the local velocity distributions for the two spinners with the propeller removed, figure 11 shows that higher thrust and power coefficients were obtained with the propeller and modified conical spinner. However, as shown in figure 10, the differences in maximum efficiency were generally of the order of the stated accuracy of the results.

Propeller Characteristics at Negative Thrust

The data presented in figure 14(a) indicate that at any constant value of advance ratio, relatively constant negative-thrust coefficients were attained at blade angles from -5° to -20° . However, as shown in figure 15(a), the power coefficients corresponding to this range of blade angles increased rapidly, indicating that use of a more negative blade angle resulted in additional power absorption rather than an increase in negative thrust. For the range of blade angles and Mach numbers covered in the present investigation, there was practically no effect of compressibility on the negative-thrust and torque characteristics of the propeller at Mach numbers up to 0.60 (see figs. 14 and 15).

Propeller Characteristics at Near Static Conditions

The thrust and torque characteristics presented in figures 16(a) and 16(b) were obtained at near static conditions, as shown by the variation of velocity with nD in figure 16(c). The abrupt decrease in thrust coefficient and increase in power coefficient at values of nD below 60 are believed to be due to the effects of Reynolds number. At these low values of nD , the blade sections were operating at Reynolds numbers less than about 500,000.

The experimental data shown in figure 16 were used to compute the static thrust per horsepower and were then plotted as a function of power disc loading for constant values of nD . The envelope of these curves is presented in figure 17. The theoretical curve shown in figure 17 was computed by the method of reference 13. The variation of static thrust per horsepower with disc loading was adequately predicted by the theory, but the experimental values were only approximately 67 percent of the theoretical ideal values. However, the theory neglects rotational losses and blade drag which presumably accounts for the discrepancy between experiment and theory.

CONCLUDING REMARKS

The following remarks may be made regarding the results of the subject investigation.

The efficiency of the propeller with the two different spinners and the cowl was higher at all Mach numbers than that of the isolated propeller-spinner combination. At design cruise conditions ($M = 0.60$, $\beta = 53^\circ$), the efficiency of the propeller with the 1-series spinner and cowl was 80 percent, as compared with 72 percent for the isolated propeller-spinner combination.

The onset of marked compressibility losses was delayed from a Mach number of 0.50 to a Mach number of 0.60 by the addition of the cowl.

The effects of inlet velocity ratio and spinner shape on the propeller characteristics were not large except at the higher Mach numbers (0.70 and 0.80).

There was practically no effect of compressibility on the characteristics of the propeller-spinner combination operating at negative thrust at Mach numbers through 0.60.

The propeller static thrust varied with power disc loading as predicted by actuator disc theory, but the experimental static thrust was only 67 percent of the theoretical ideal thrust.

Ames Aeronautical Laboratory
National Advisory Committee for Aeronautics
Moffett Field, Calif., Feb. 18, 1954

REFERENCES

1. Sammonds, Robert I., and Molk, Ashley J.: Effects of Propeller-Spinner Juncture on the Pressure-Recovery Characteristics of an NACA 1-Series D-Type Cowl in Combination With a Four-Blade Single-Rotation Propeller at Mach Numbers up to 0.83 and at an Angle of Attack of 0° . NACA RM A52D01a, 1952.
2. Reynolds, Robert M., Sammonds, Robert I., and Kenyon, George C.: An Investigation of a Four-Blade Single-Rotation Propeller in Combination With an NACA 1-Series D-Type Cowling at Mach Numbers up to 0.83. NACA RM A53B06, 1953.
3. Keith, Arvid L., Jr., Bingham, Gene J., and Rubin, Arnold J.: Effects of Propeller-Shank Geometry and Propeller-Spinner Juncture Configuration on Characteristics of an NACA 1-Series Cowling-Spinner Combination With an Eight-Blade Dual-Rotation Propeller. NACA RM L51F26, 1951.
4. Bingham, Gene J., and Keith, Arvid L., Jr.: Effects of Compressibility at Mach Numbers up to 0.8 on Internal-Flow Characteristics of a Cowling-Spinner Combination Equipped With an Eight-Blade Dual-Rotation Propeller. NACA RM L53E12, 1953.
5. Reynolds, Robert M., and Sammonds, Robert I.: Subsonic Mach and Reynolds Number Effects on the Surface Pressures, Gap Flow, Pressure Recovery, and Drag of a Nonrotating NACA 1-Series E-Type Cowling at an Angle of Attack of 0° . NACA RM A51E03, 1951.
6. Molk, Ashley J., and Reynolds, Robert M.: Effects of Two Spinner Shapes on the Pressure Recovery in an NACA 1-Series D-Type Cowl Behind a Three-Blade Propeller at Mach Numbers Up to 0.80. NACA RM A53L29a, 1953.
7. Reynolds, Robert M.: Preliminary Results of an Investigation of the Effects of Spinner Shape on the Characteristics of an NACA D-Type Cowl Behind a Three-Blade Propeller, Including the Characteristics of the Propeller at Negative Thrust. NACA RM A53J02, 1953.

8. Reynolds, Robert M., Buell, Donald A., and Walker, John H.: Investigation of an NACA 4-(5)(05)-041 Four-Blade Propeller With Several Spinners at Mach Numbers up to 0.90. NACA RM A52I19a, 1952.
9. Herriot, John G.: Blockage Corrections for Three-Dimensional-Flow Closed-Throat Wind Tunnels, With Consideration of the Effect of Compressibility. NACA Rep. 995, 1950. (Supersedes NACA RM A7B28)
10. Young, A. D.: Note on the Application of the Linear Perturbation Theory to Determine the Effect of Compressibility on the Wind Tunnel Constraint on a Propeller. R.A.E. TN No. Aero. 1539, British, 1944.
11. Delano, James Benjamin, and Carmel, Melvin M.: Investigation of the NACA 4-(5)(08)-03 Two-Blade Propeller at Forward Mach Numbers to 0.925. NACA RM L9G06a, 1949.
12. Glauert, H.: Airplane Propellers Body and Wing Interference. Vol. IV of Aerodynamic Theory, div. L, ch. VIII, W. F. Durand, ed. Julius Springer (Berlin), 1935. (CIT reprint 1943)
13. Gilman, Jean, Jr.: Analytical Study of Static and Low-Speed Performance of Thin Propellers Using Two-Speed Gear Ratios to Obtain Optimum Rotational Speeds. NACA RM L52I09, 1952.

TABLE I.- LOCAL VELOCITY RATIO, U/V - Concluded

(c) The 1-series spinner, no cowl

Radial station, in.	M=0.15	M=0.20	M=0.40	M=0.50	M=0.60	M=0.70	M=0.80
3.44	1.071	1.079	1.088	1.092	1.102	1.108	1.124
3.69	1.070	1.078	1.082	1.095	1.102	1.109	1.124
3.94	1.063	1.068	1.077	1.079	1.089	1.094	1.107
4.19	1.049	1.063	1.062	1.067	1.076	1.081	1.092
4.44	1.042	1.057	1.059	1.063	1.071	1.076	1.088
4.94	1.021	1.037	1.043	1.046	1.059	1.064	1.071
5.44	1.020	1.030	1.035	1.038	1.050	1.052	1.065
5.94	1.019	1.029	1.028	1.036	1.044	1.046	1.055
6.44	1.013	1.019	1.020	1.024	1.031	1.034	1.043
7.44	1.005	1.018	1.014	1.014	1.023	1.027	1.032
8.44	.997	1.012	1.015	1.014	1.023	1.027	1.033
9.44	1.003	1.011	1.008	1.014	1.021	1.025	1.035
10.44	1.002	1.005	1.005	1.006	1.011	1.013	1.013
12.44	1.001	1.004	1.001	1.004	1.004	1.005	1.005
14.44	.999	.997	1.005	1.003	1.006	1.007	1.004
16.44	.998	.996	.999	.997	1.002	1.003	1.001
18.44	.997	.995	.996	.996	1.002	1.002	1.000
20.44	.997	1.000	1.000	1.004	1.004	1.005	1.001
22.44	.899	.999	.997	1.001	1.001	1.002	1.000
24.44	1.003	1.009	1.001	1.004	1.002	1.003	.998
26.44	.995	1.003	1.000	1.002	1.005	1.003	.997
28.44	1.002	1.008	1.001	1.001	1.004	1.005	.999
30.44	1.002	1.008	1.003	1.001	1.003	1.003	1.001
32.44	1.001	1.007	1.004	1.006	1.008	1.004	1.001

NACA



Figure 1.- The model mounted on the 1000-horsepower propeller dynamometer in the 12-foot pressure wind tunnel.

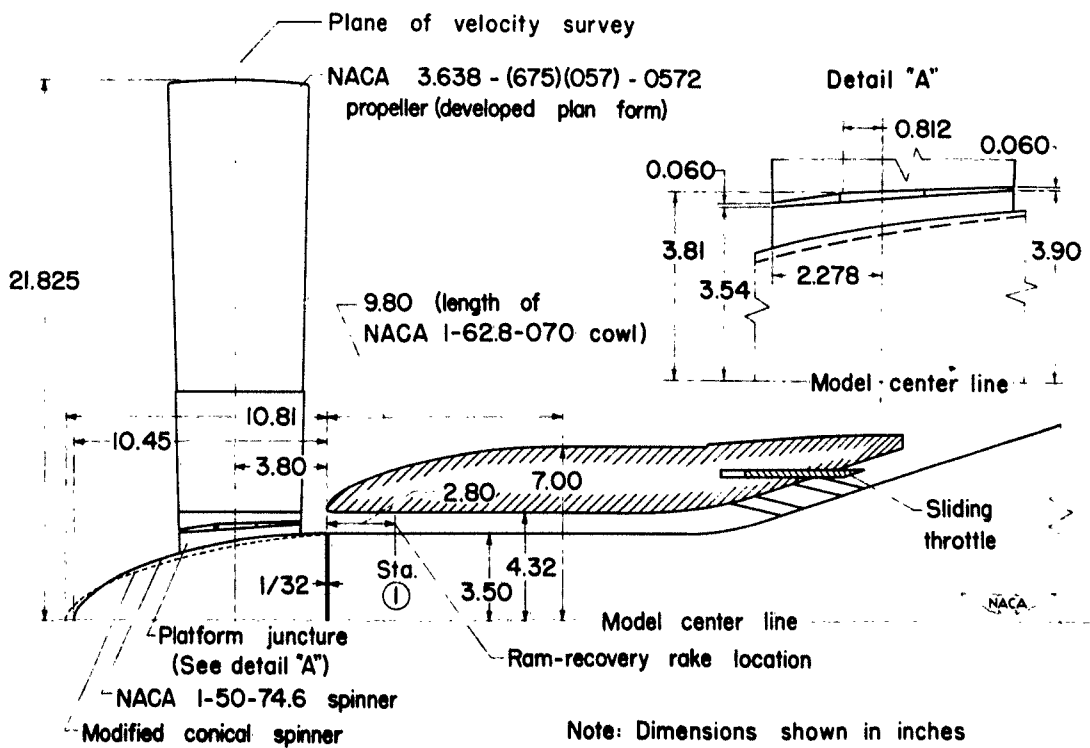

Figure 2.- Model arrangement.

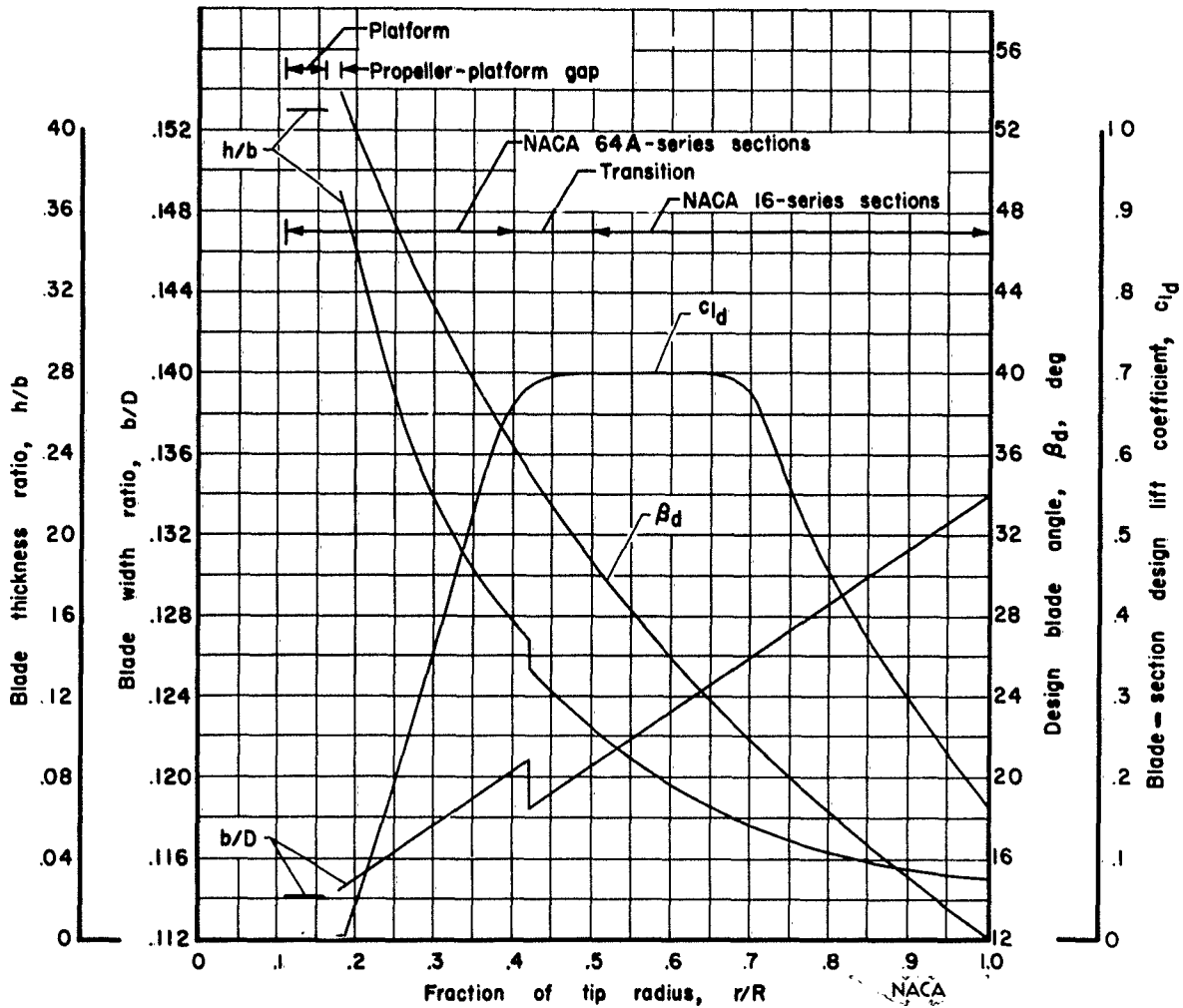

Figure 3.- Plan-form and blade-form curves for the model propeller having the designation NACA 3.638-(675)(057)-0572.

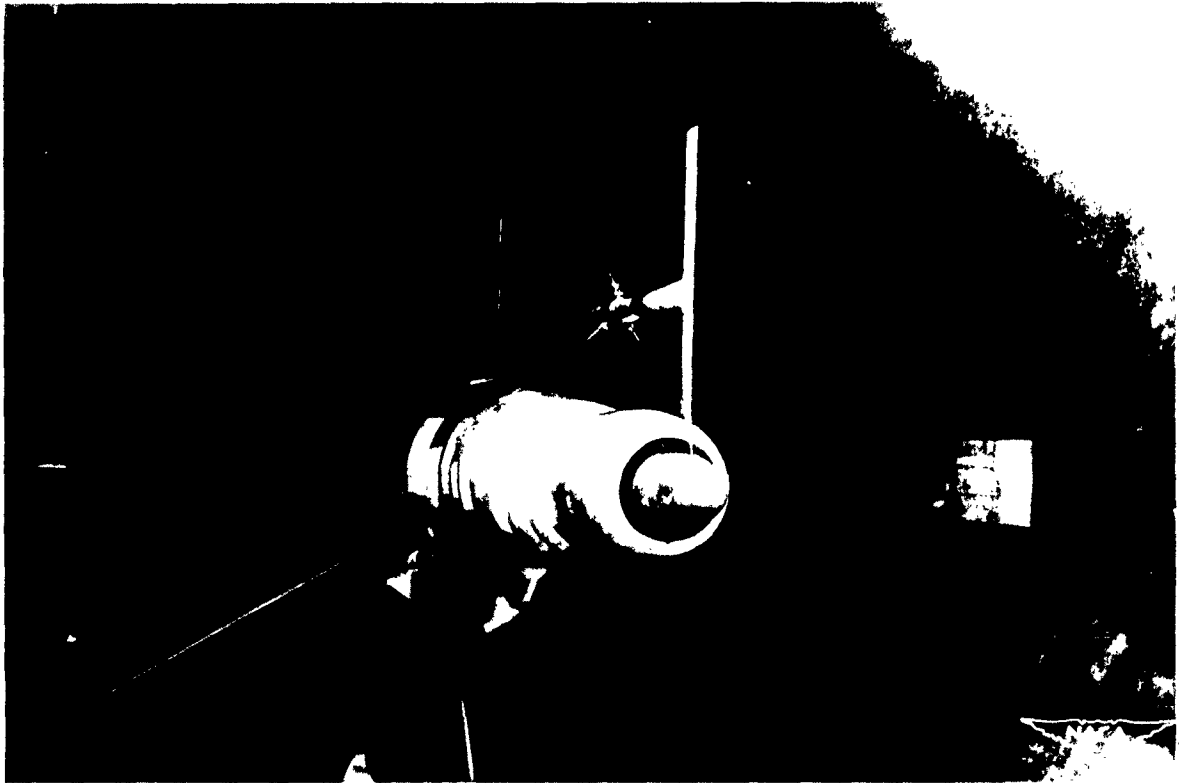

Figure 4.- Photograph of the survey rake.

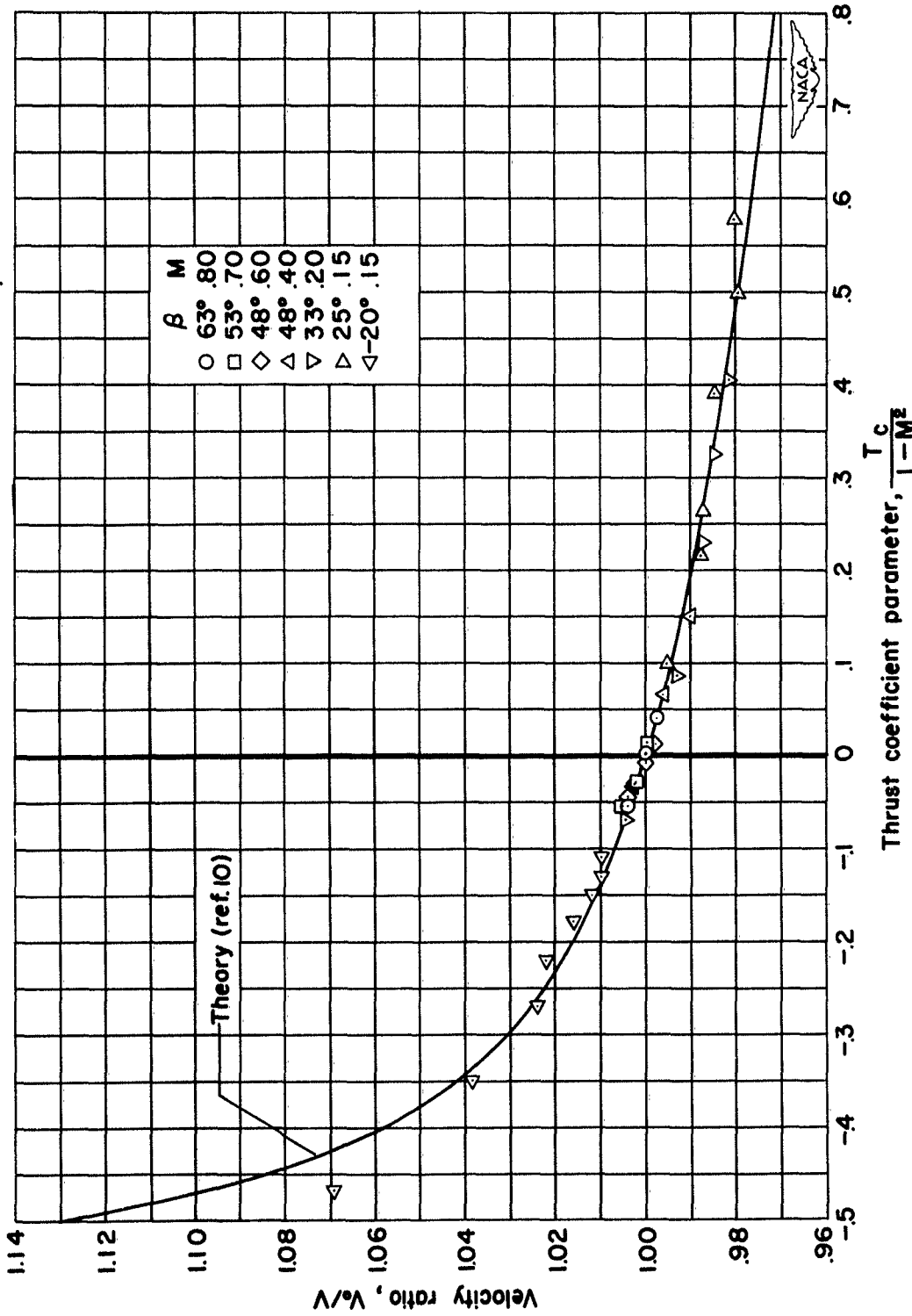
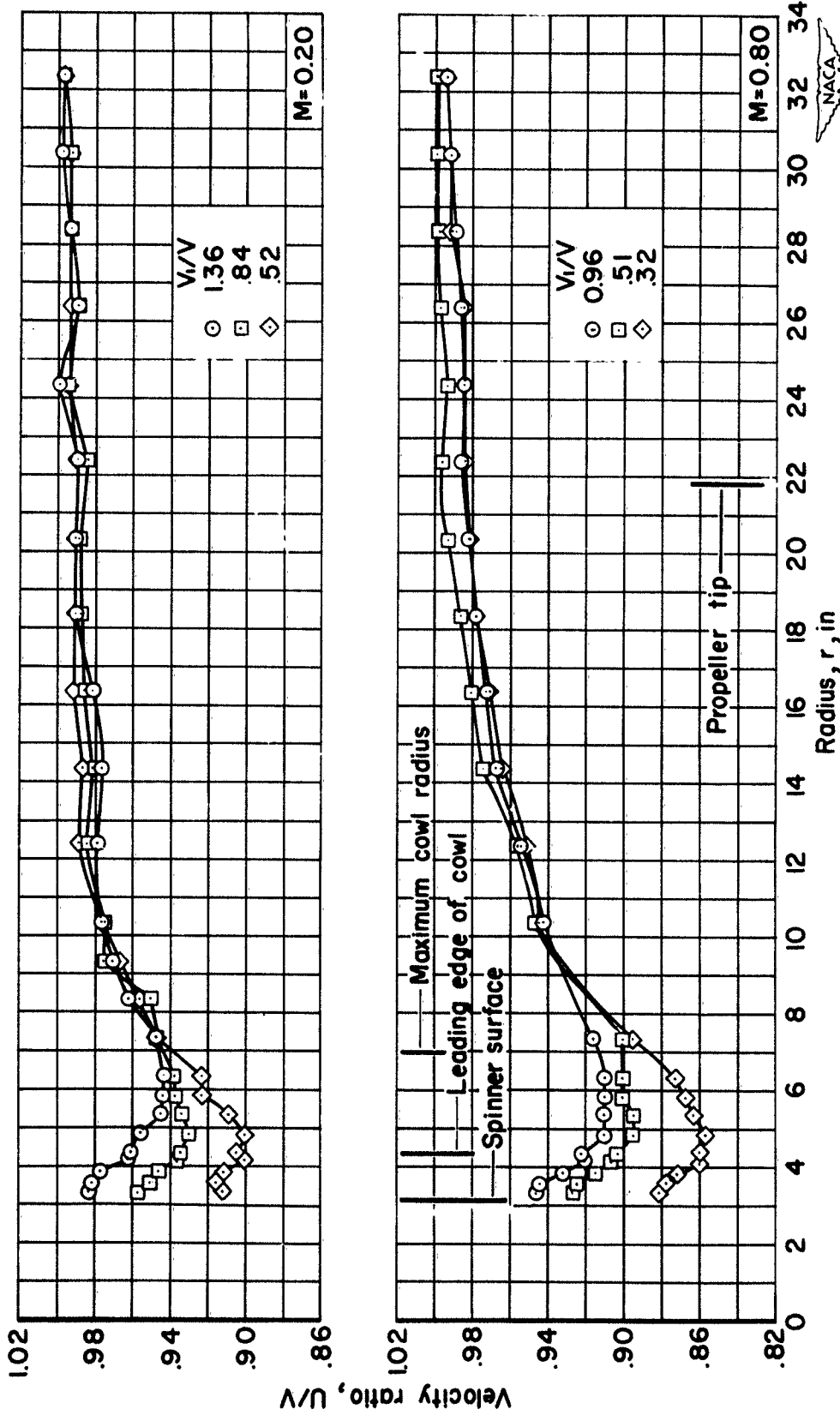
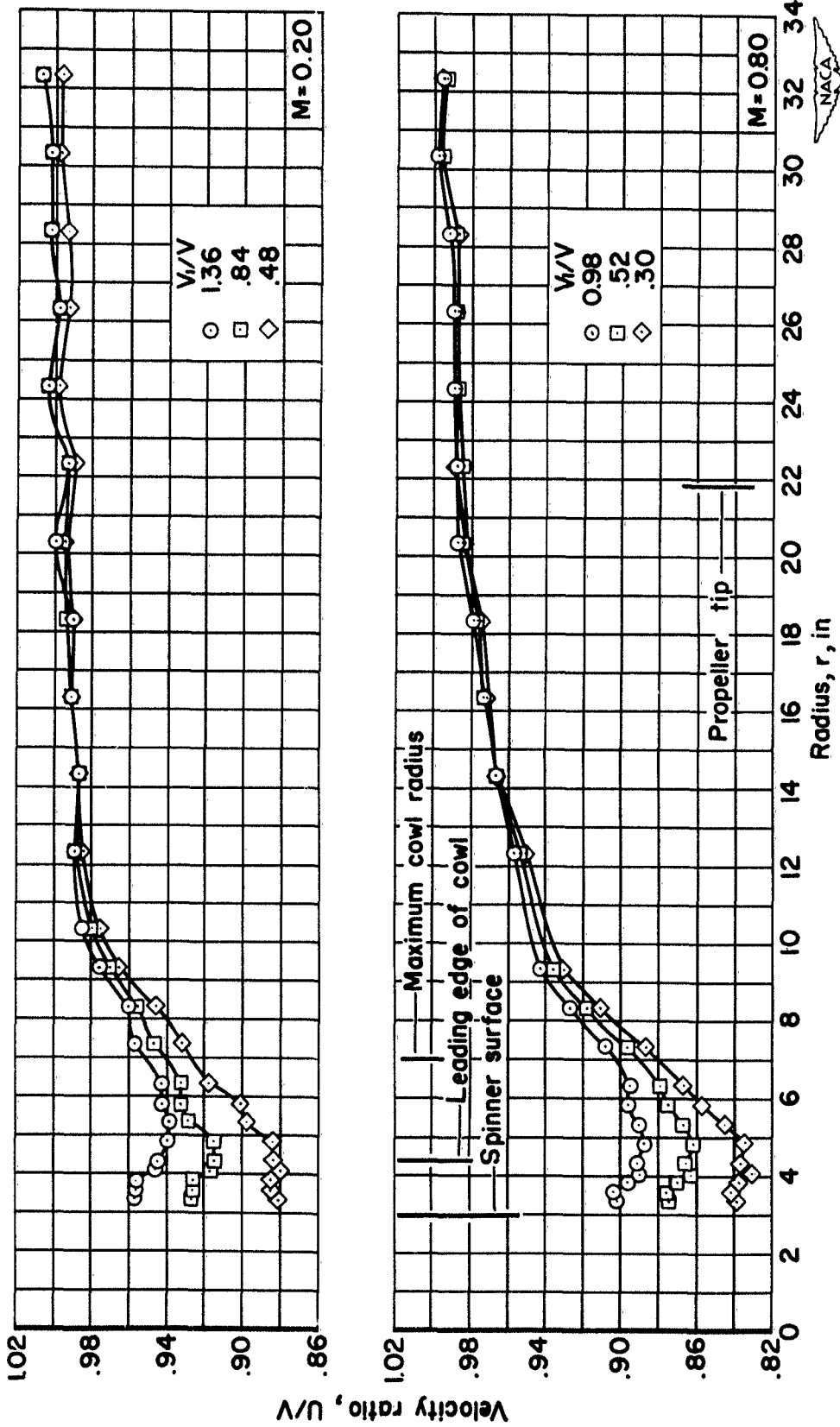

Figure 5.- Tunnel-wall-interference correction for a 3.6-foot-diameter propeller in the Ames 12-foot pressure wind tunnel.



(a) The L-series spinner with cowl.

Figure 6.- Typical radial distributions of the local velocity ratio in the plane of the propeller.



(b) Modified conical spinner with cowl.

Figure 6.- Continued.

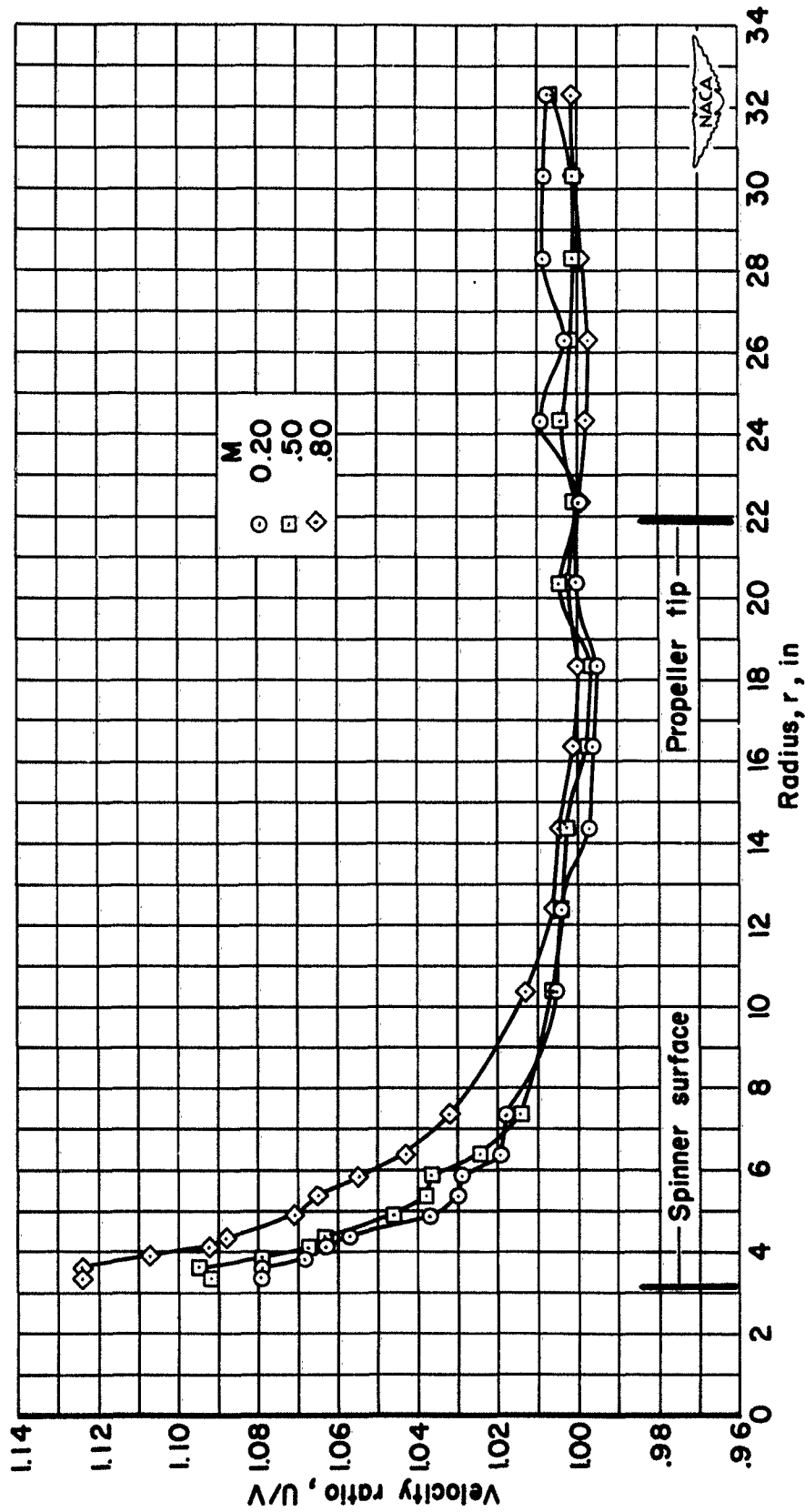

(c) The 1-series spinner, nc cowl.

Figure 6.- Concluded.

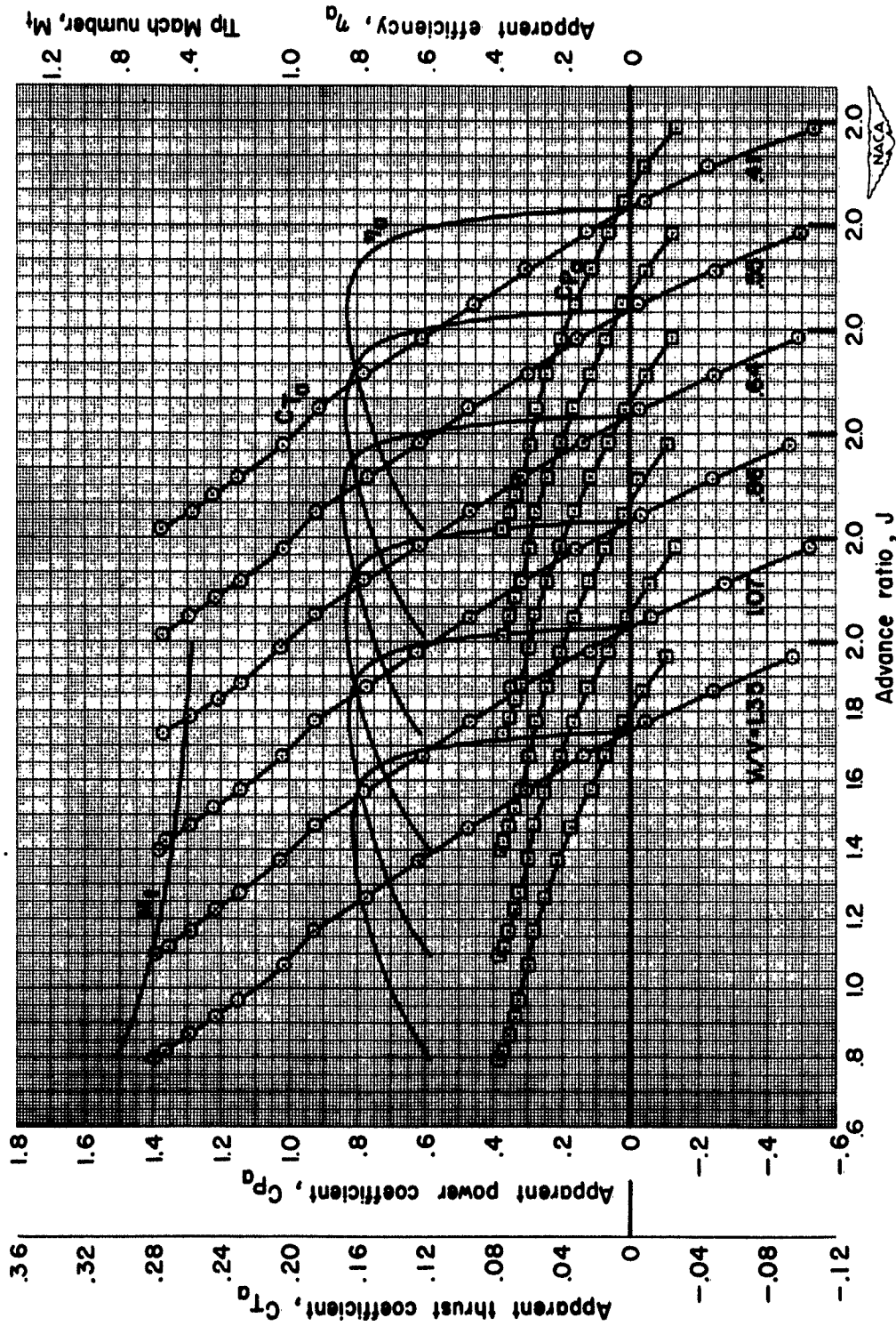

(a) $M = 0.20$, $\beta = 33^\circ$

Figure 7.- Characteristics of the propeller with the 1-series spinner and cowl.

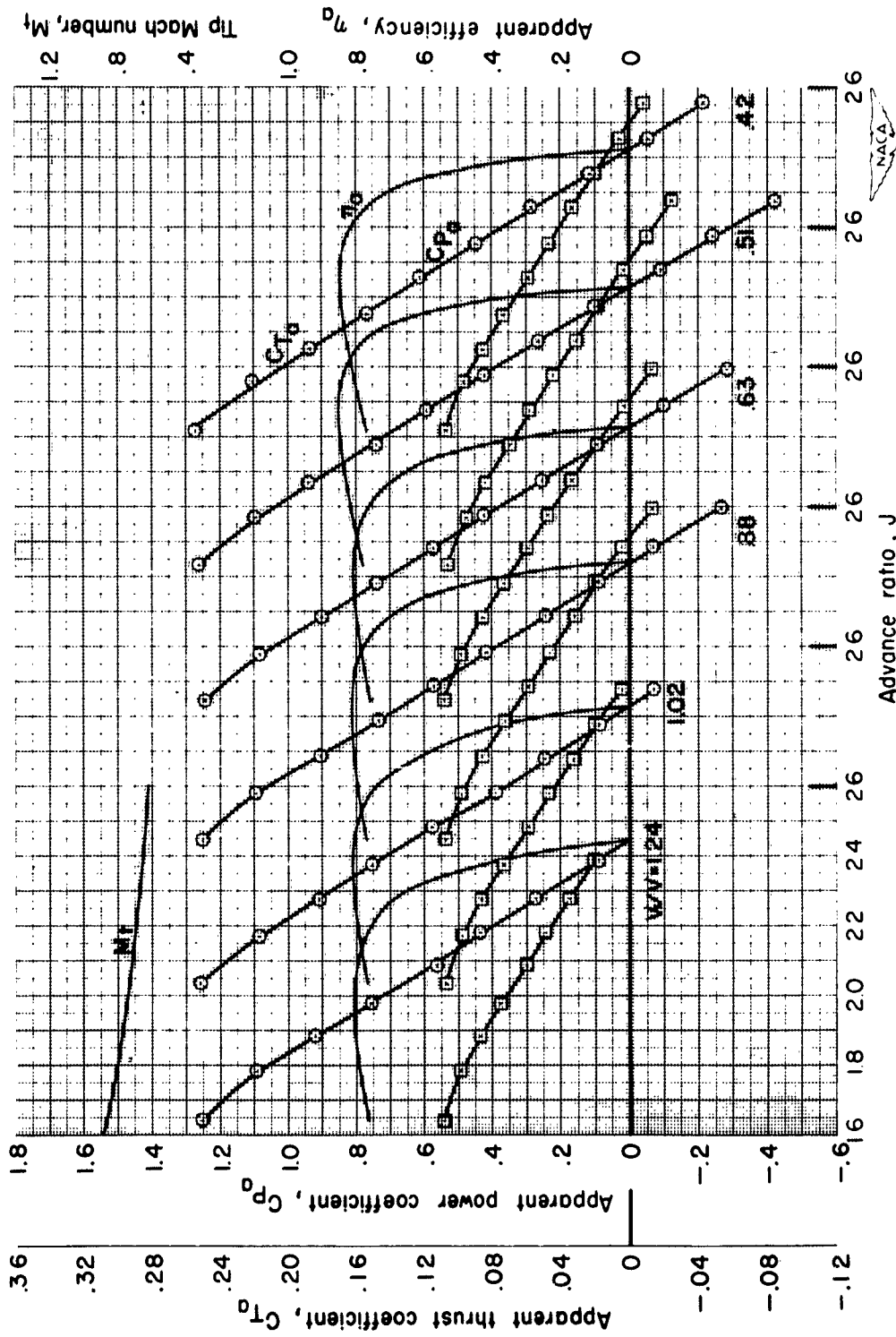

(b) $M = 0.46, \beta = 4.0$

Figure 7.- Continued.

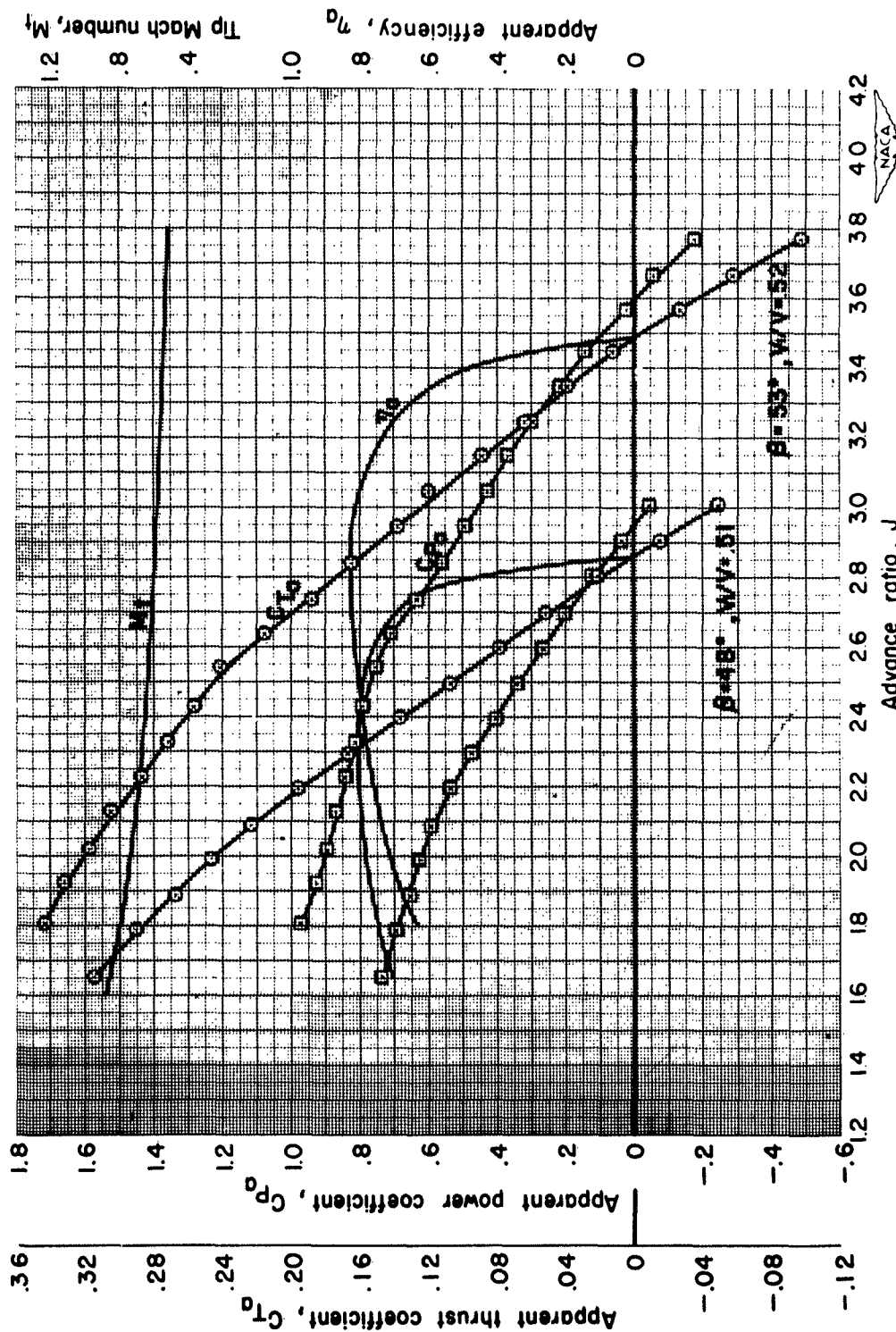

(c) $M = 0.40, R = 4.0^2$ and 5.0^2

Figure 7.- Continued.

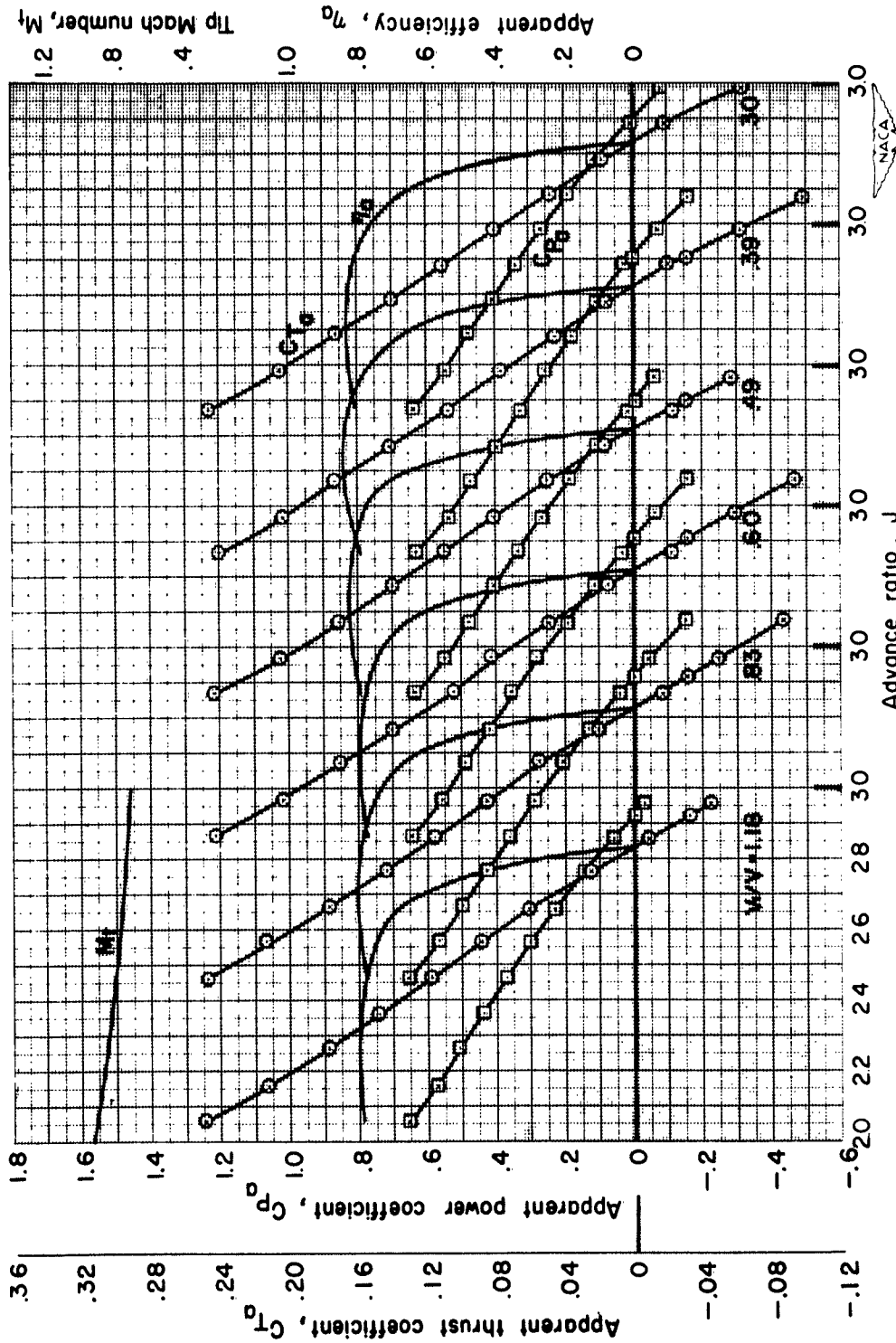

(d, $M = 0.50, \beta = 43^\circ$)

Figure 7.- Continued.

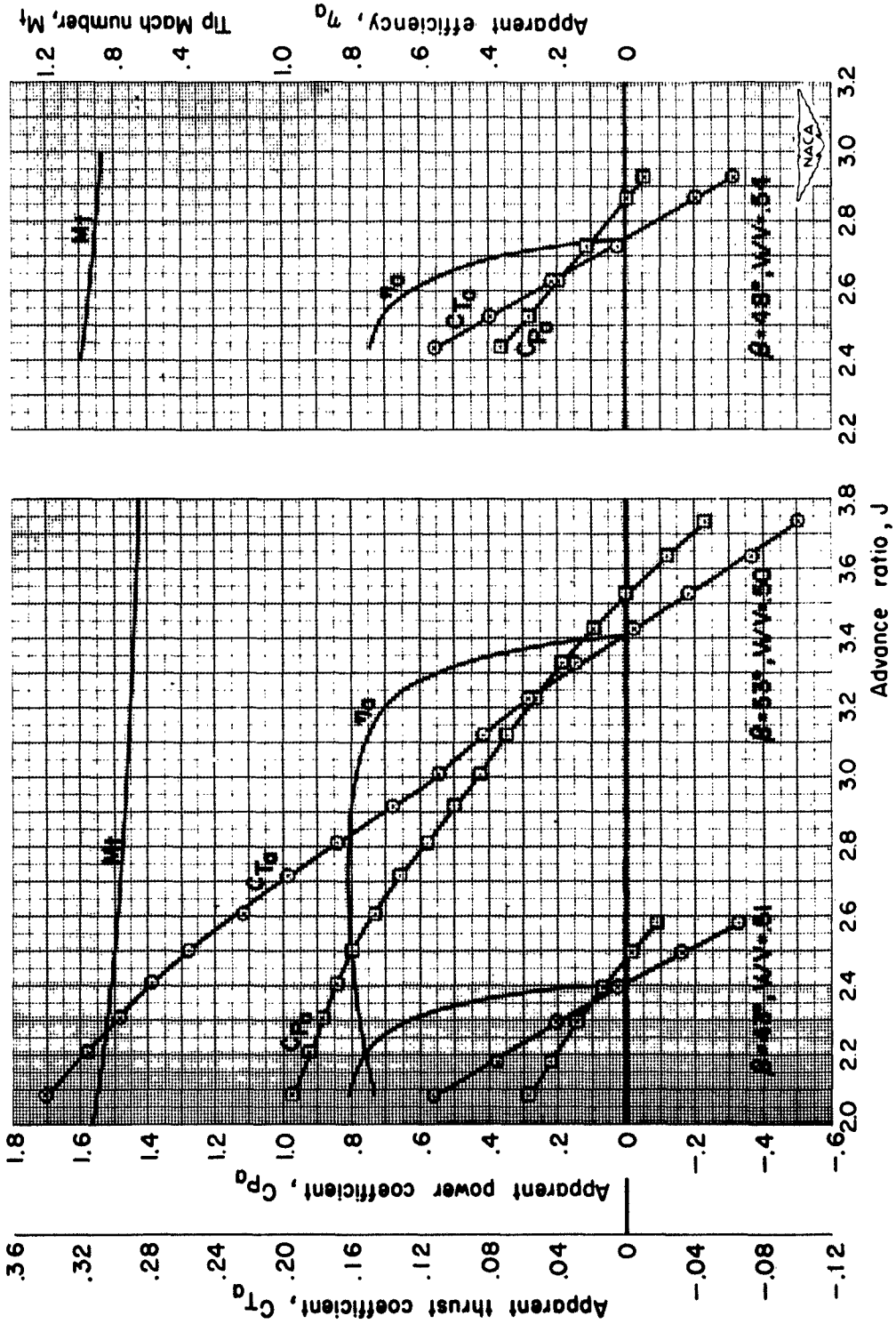

(f) $M = 0.40, \beta = 48^\circ$

(e) $M = 0.50, \beta = 47^\circ$ and 53°

Figure 7.- Continued.

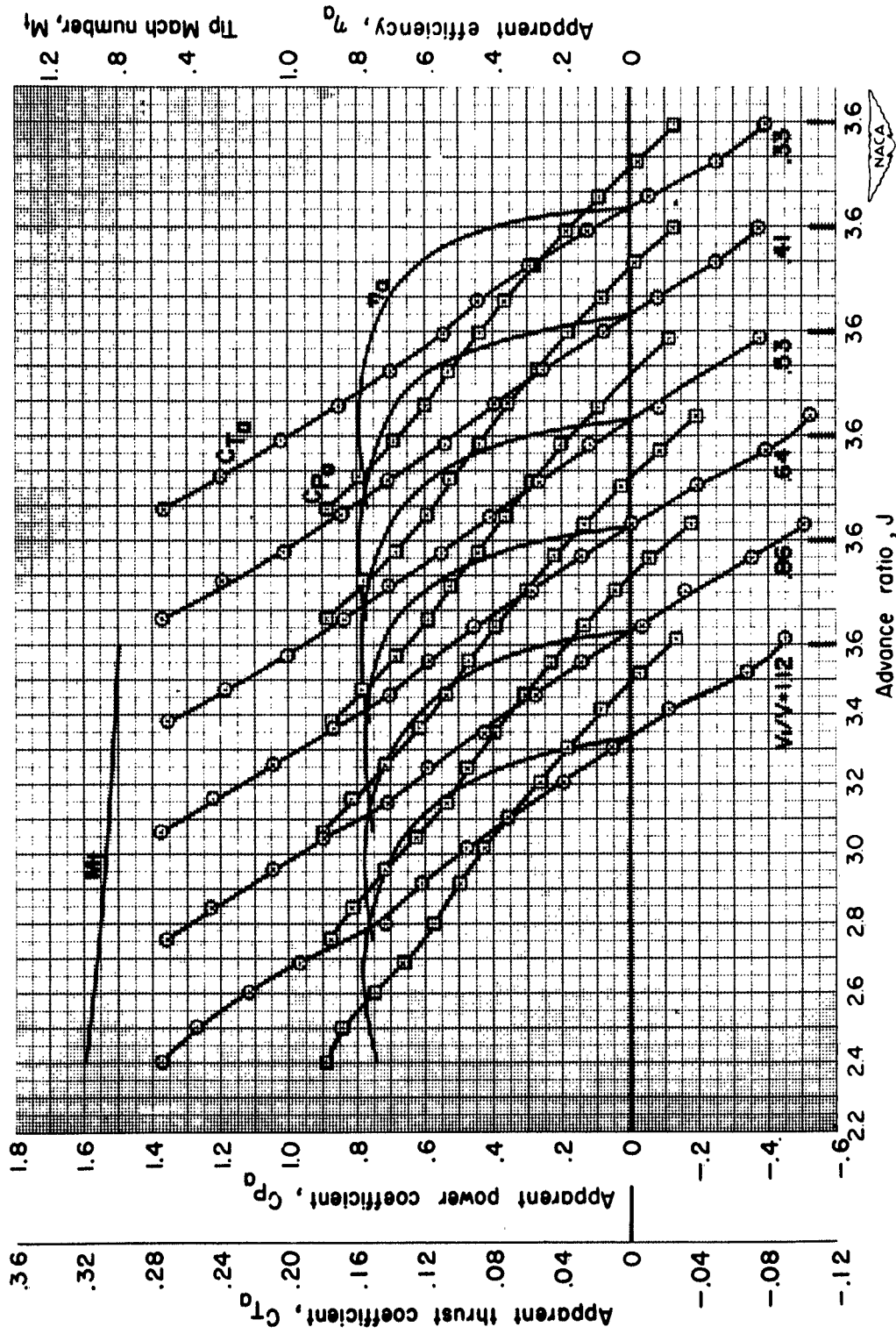

(r) $M = 0.70, R = 5.2$

Figure 7.- Continued.

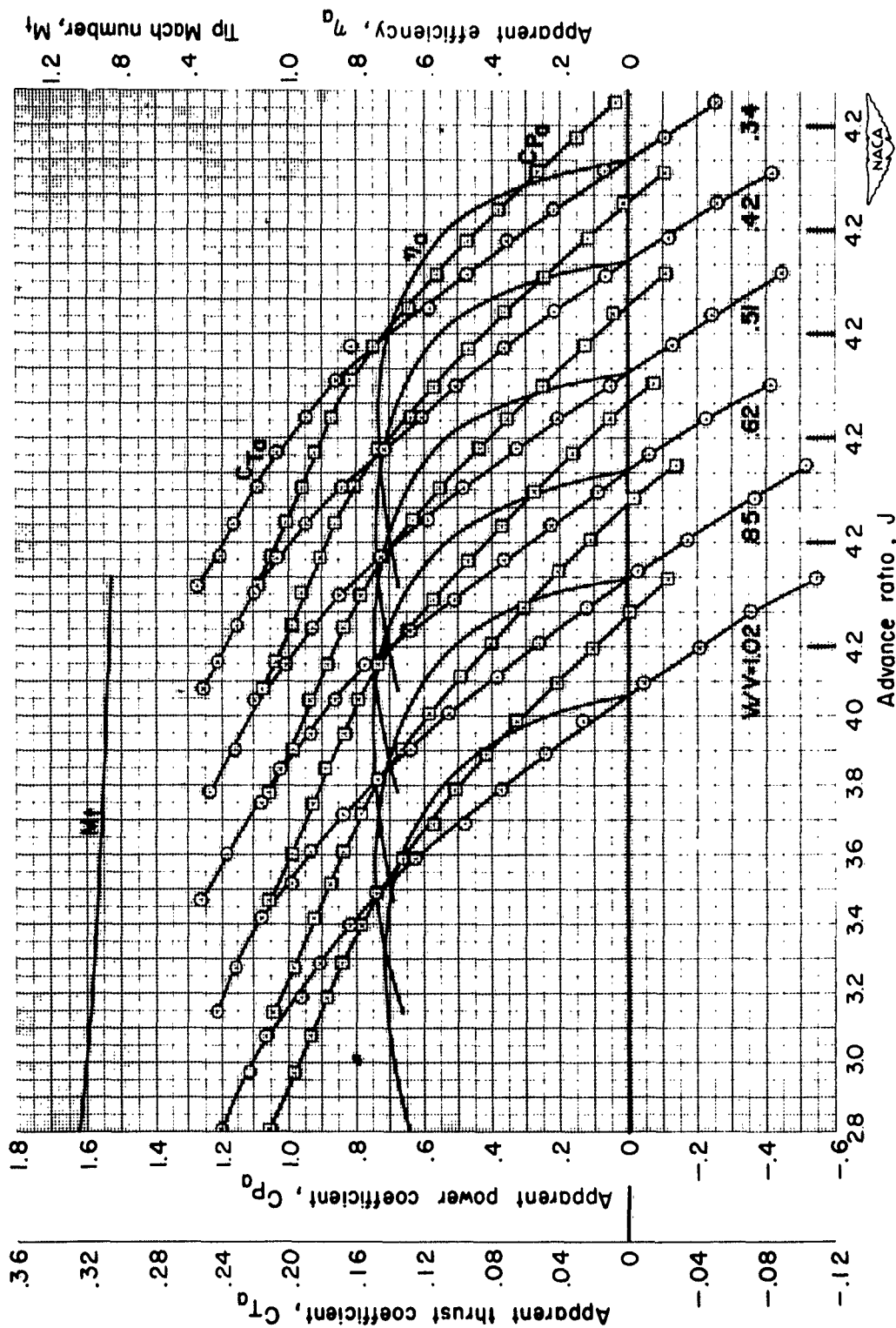

(h) $M = 0.70, \alpha = 53.5^\circ$

Figure 7.- Continued.

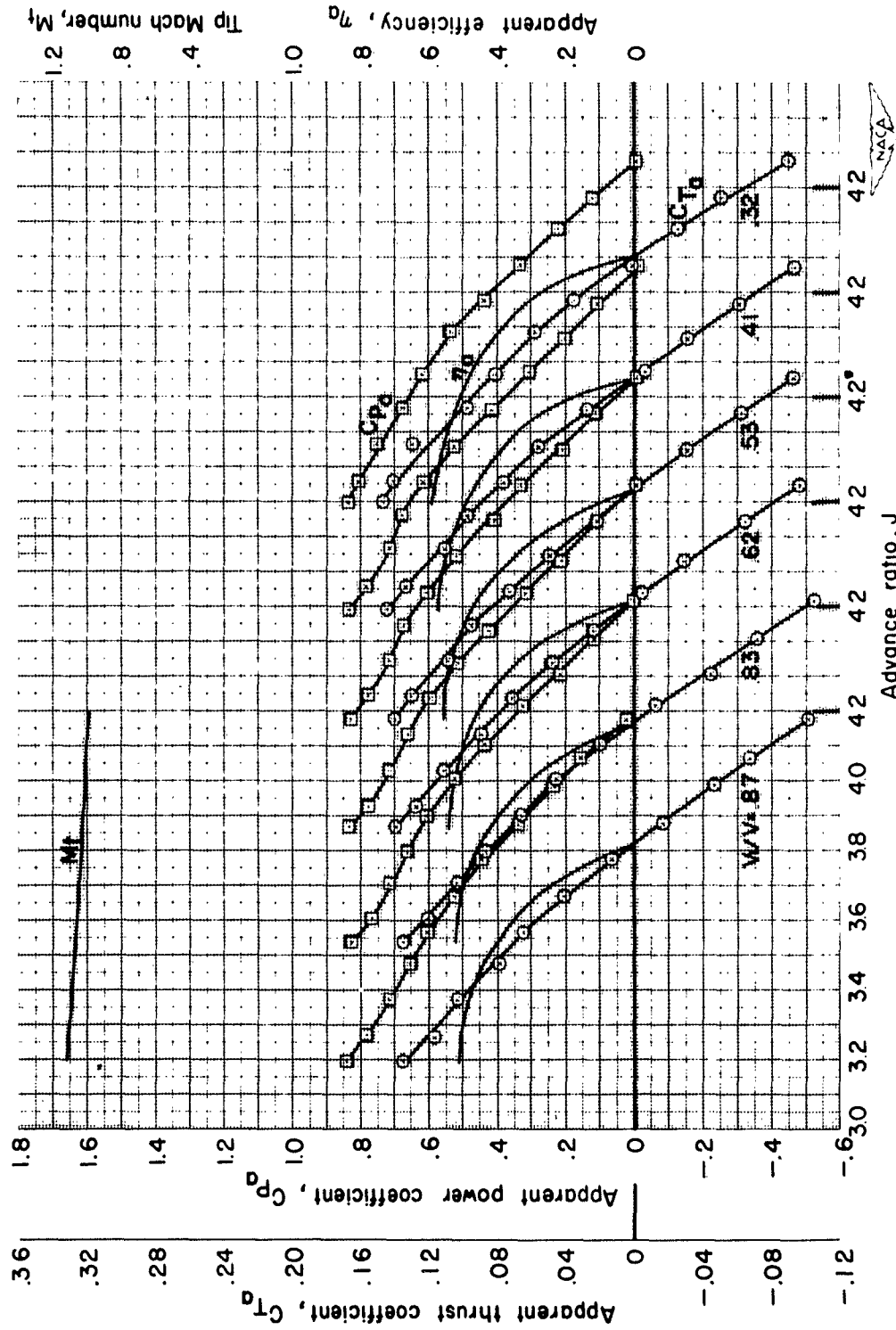

(1) $M = 0.10$, $\gamma = 56.5^\circ$

Figure 7.- Concluded.

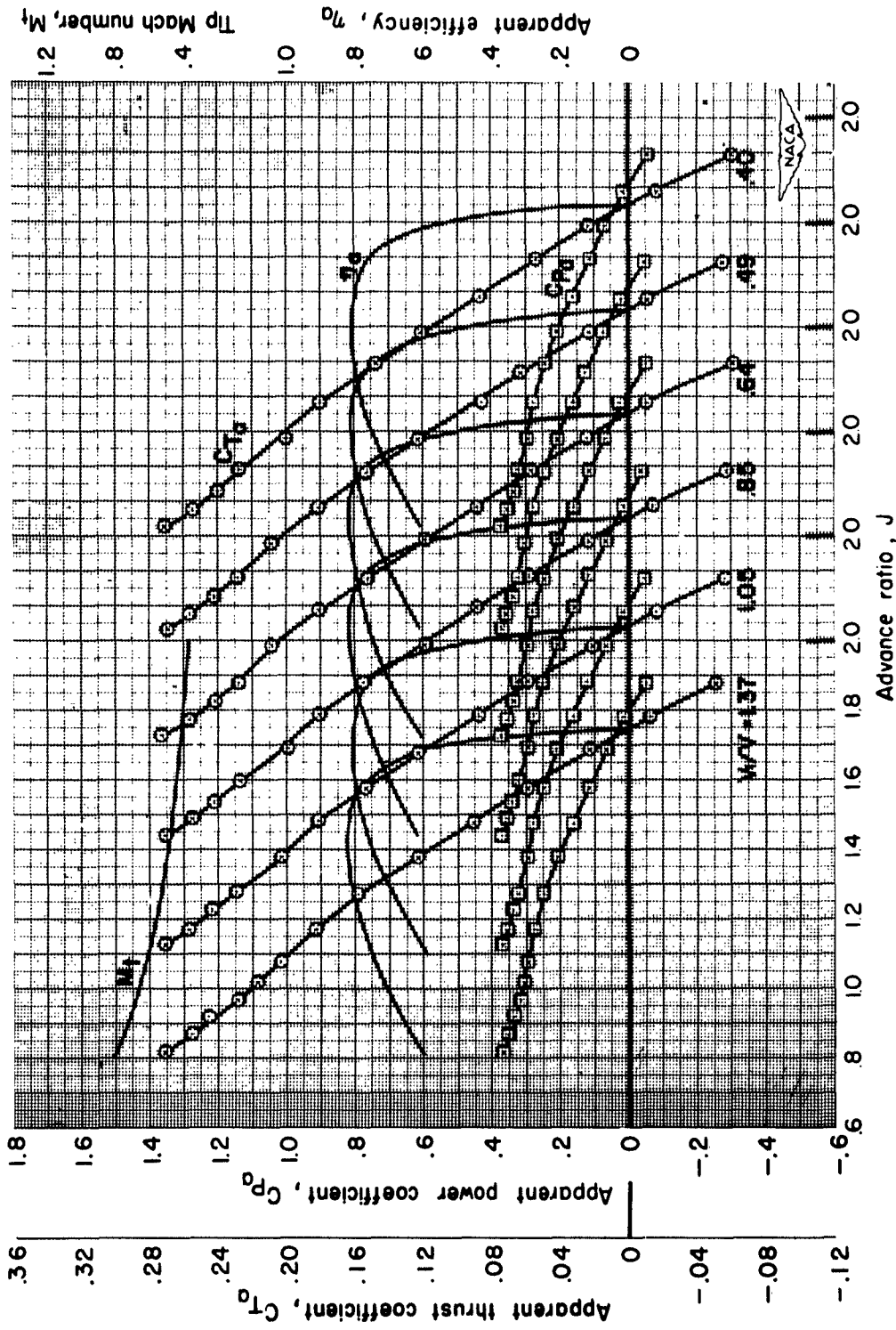

(a) $M = 0.0$, $\beta = 3.0$

Figure 8.- Characteristics of the propeller with the modified conical spinner and cowl.

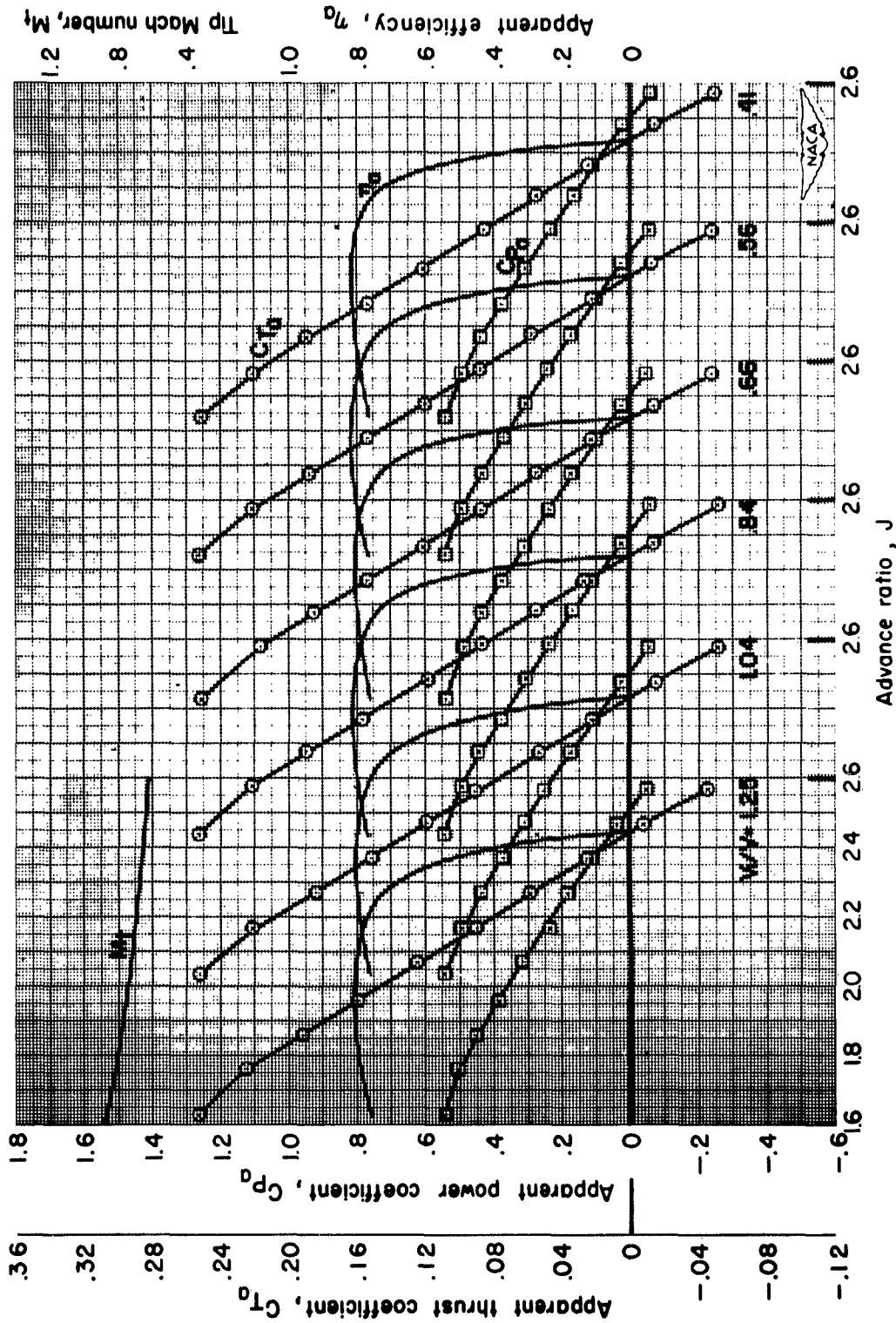

(1) $M = 0.40, \beta = 4.0$

Figure 8.- Continued.

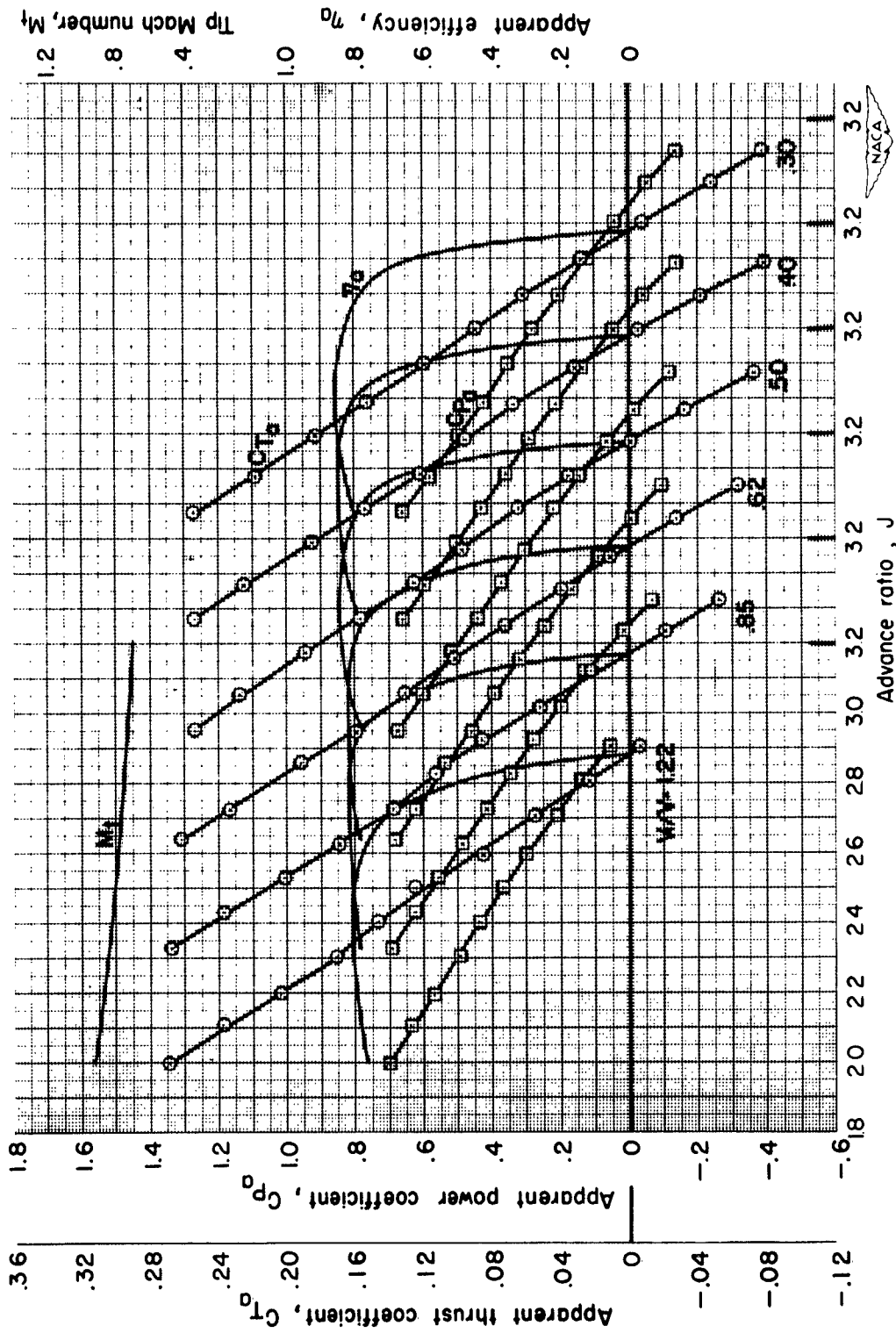

(c) $M = 0.5$, $\beta = 40^\circ$

Figure 6.- Continued.

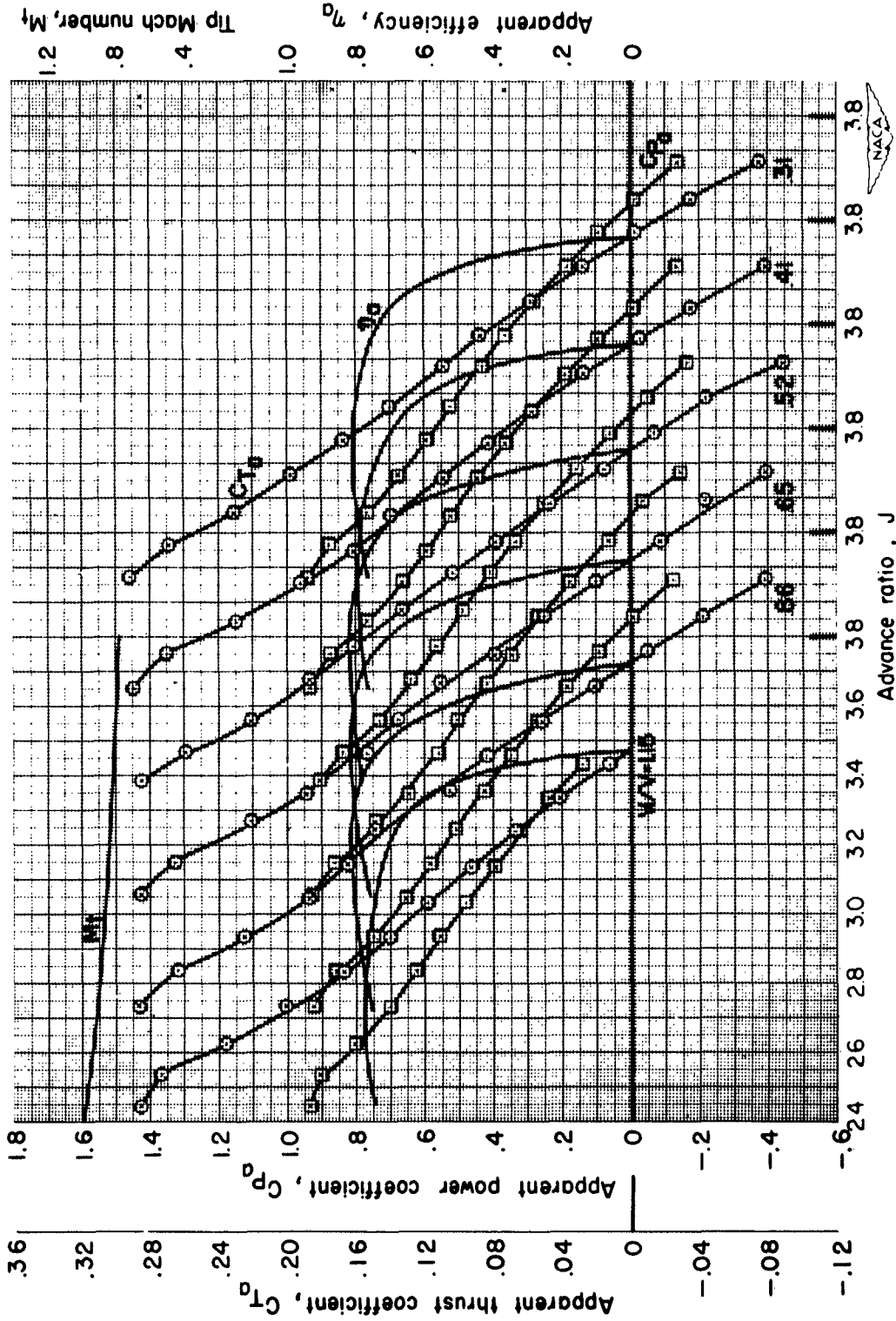

(1) $M_t = 0.2$ to 10.0
Figure 1 - Continued.

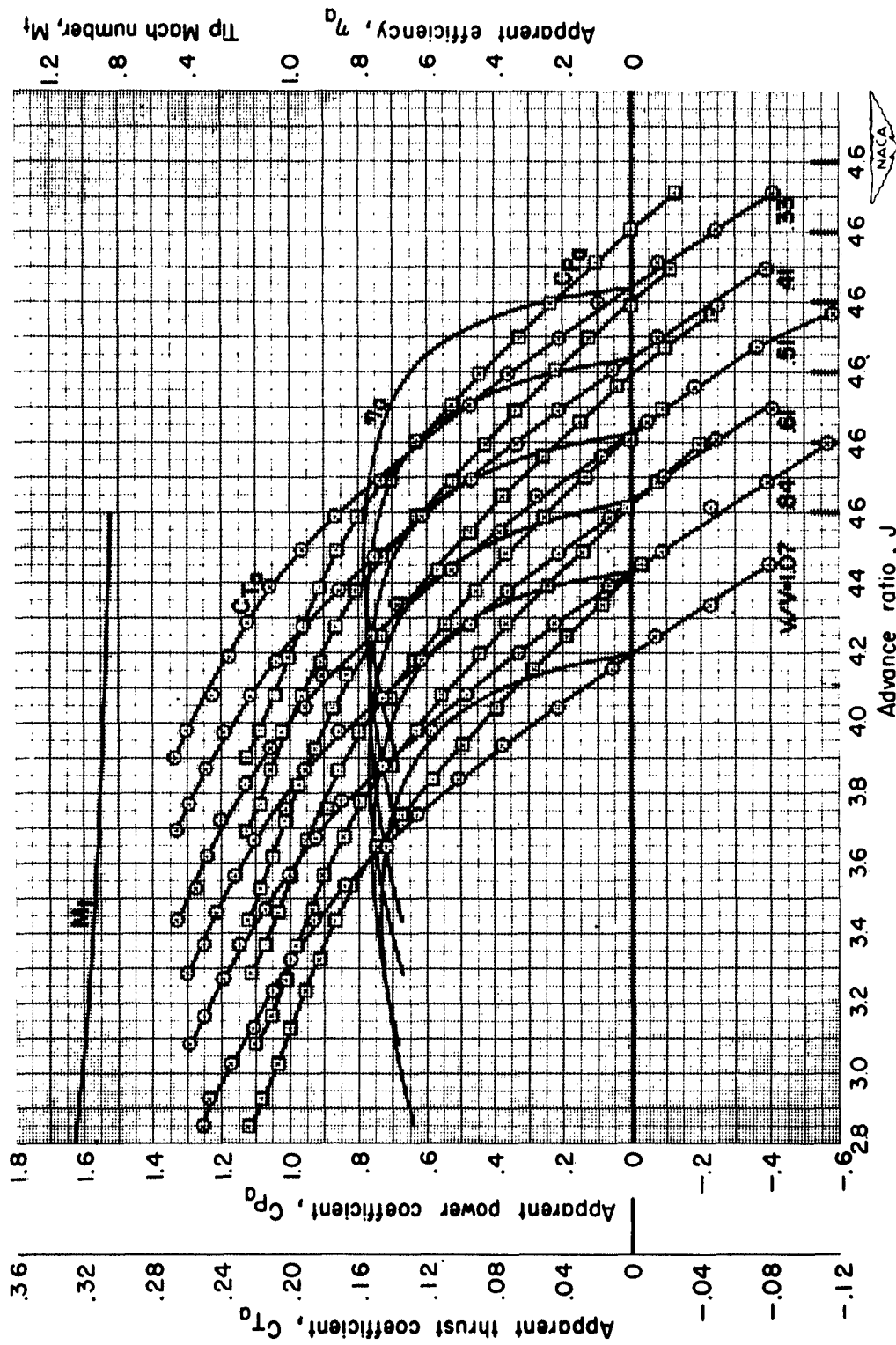

(continued)

Figure 11. - Continued.

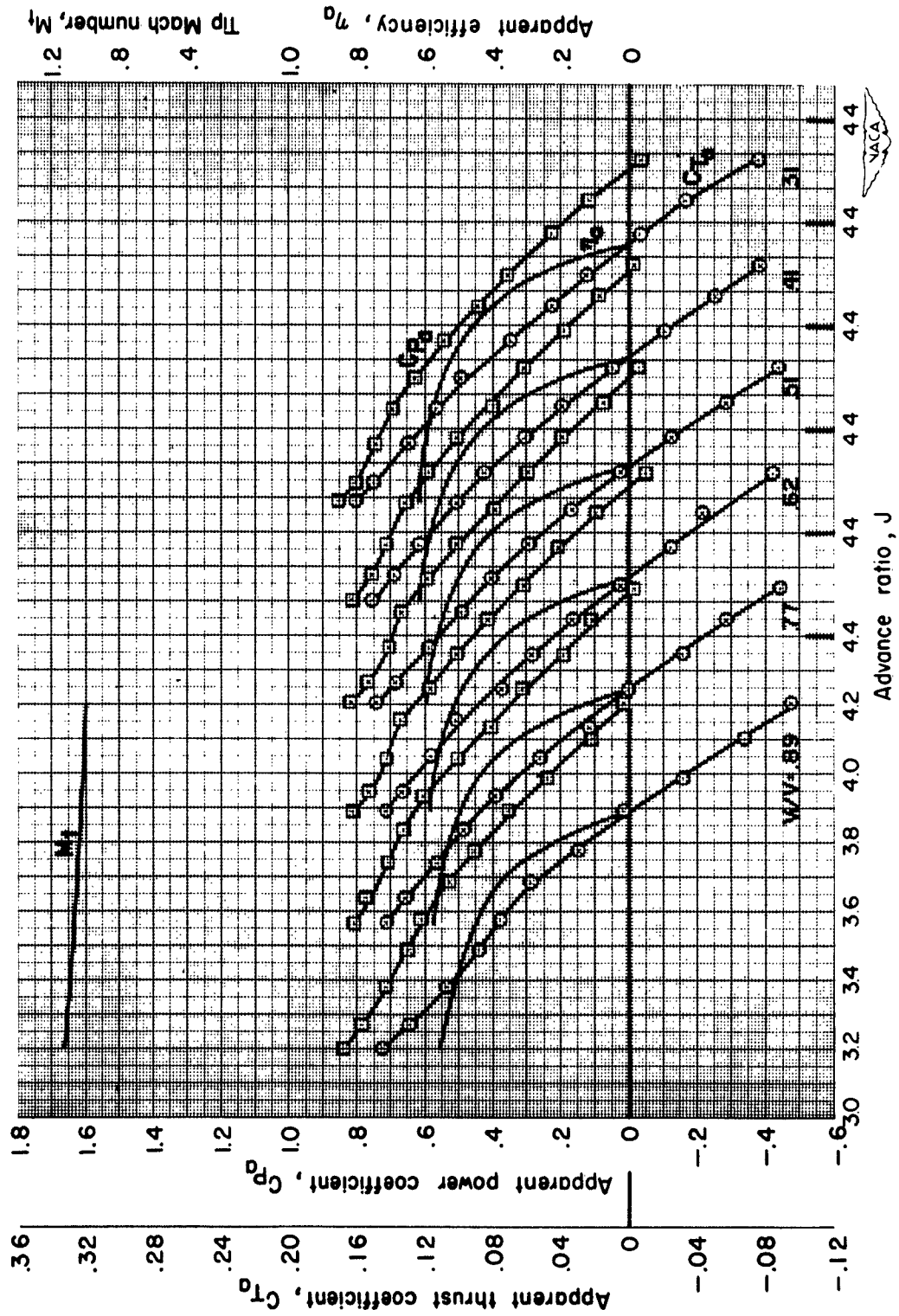

(C) $M_t = 0.77, 0.89, 0.92, 0.95, 0.98, 1.0, 1.05, 1.1, 1.15, 1.2$

Figure 1 - Continued.

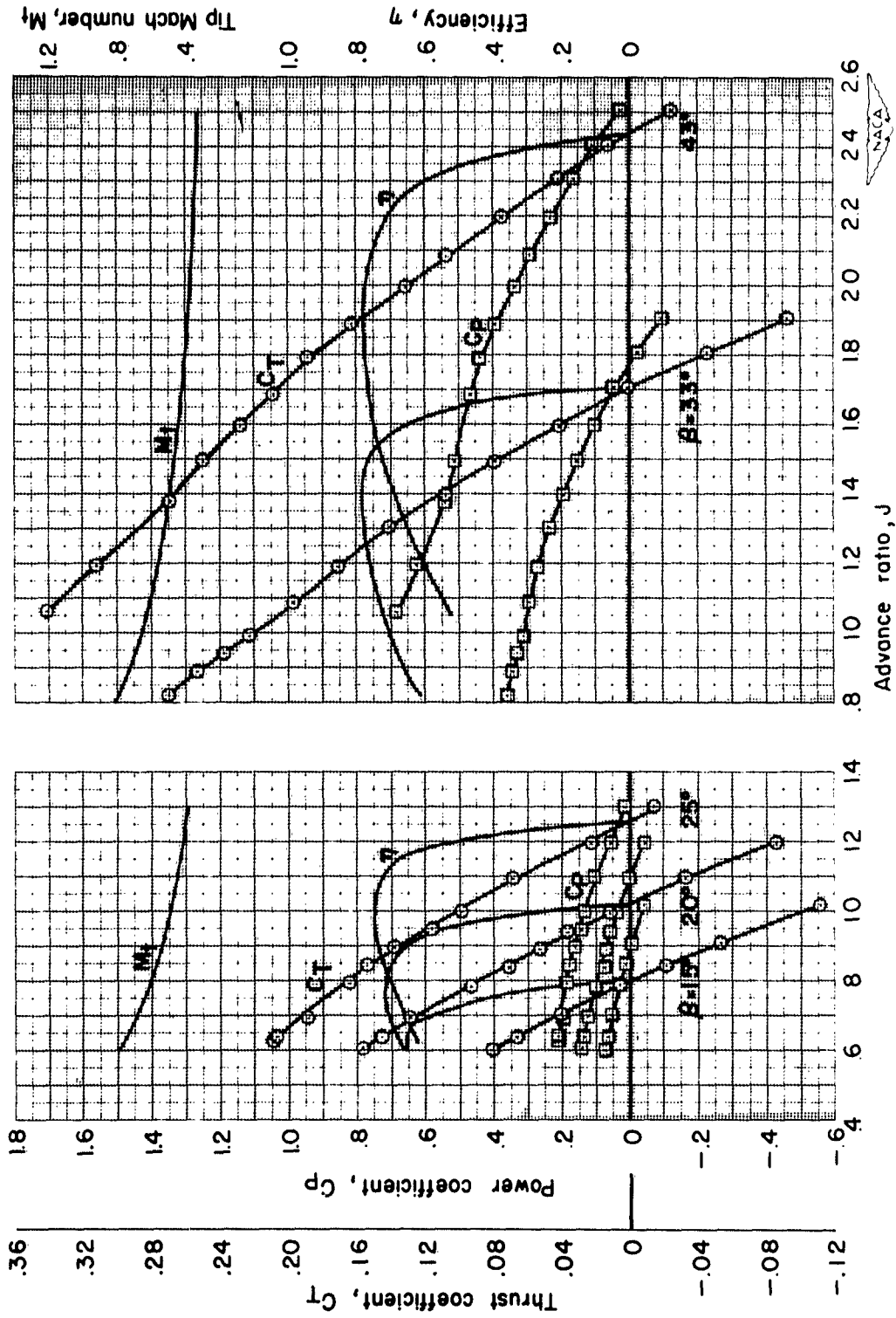

(a) $\beta = 1.5, 2.0, 2.5$

Figure 4.- Performance of the 10-bladed propeller.

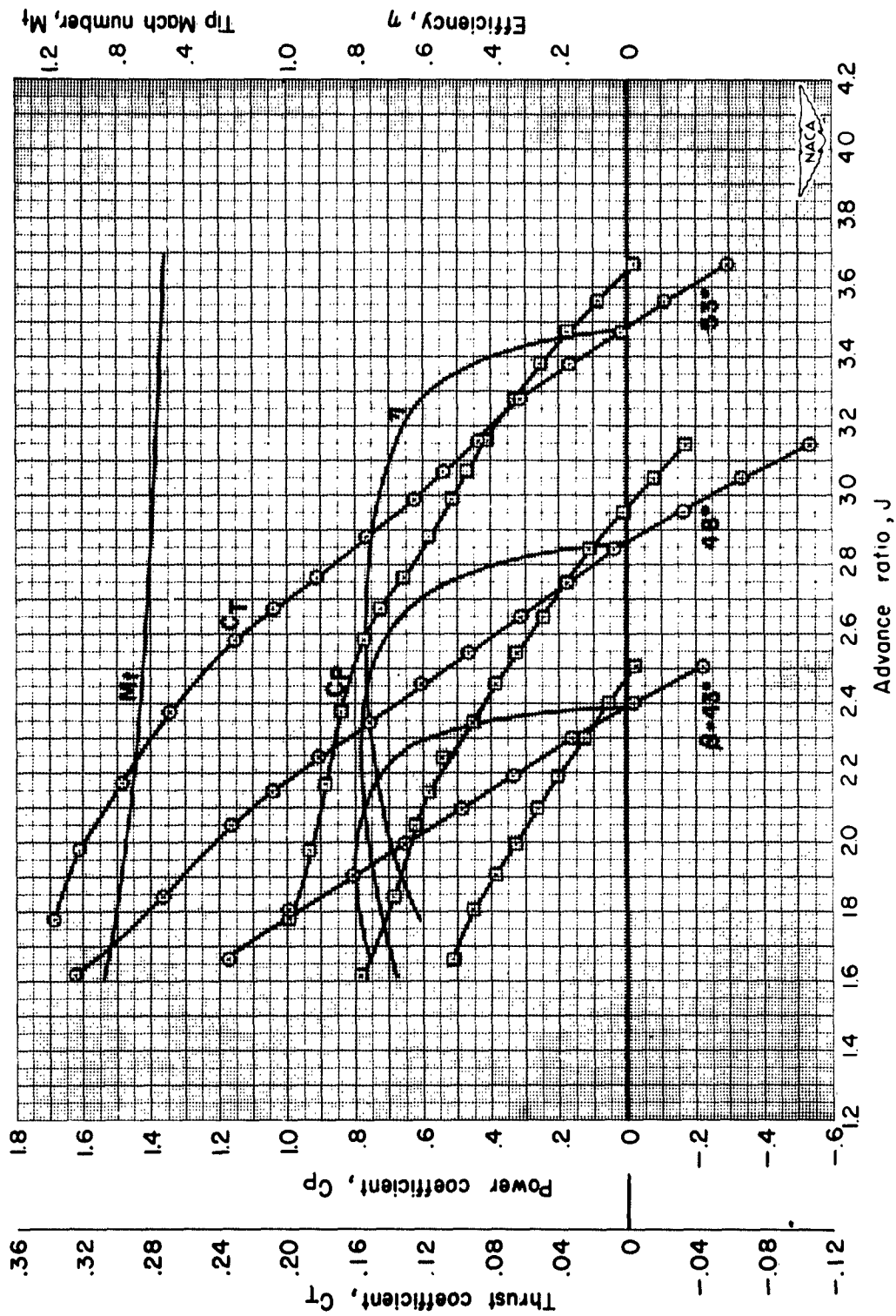

(c) $M = 0.10$

Figure 9.- Continued.

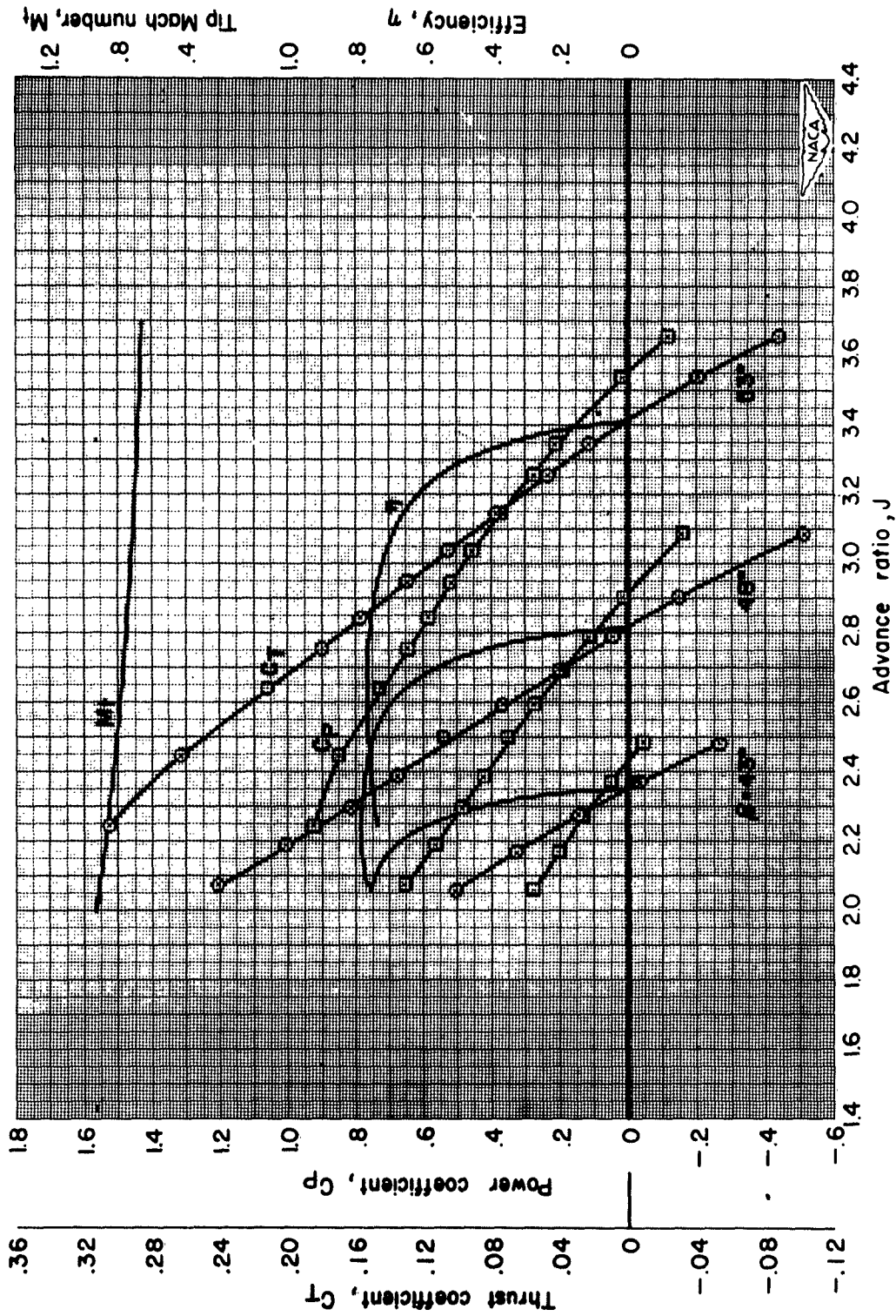

(d) $M = 0.50$

Figure 9.- Continued.

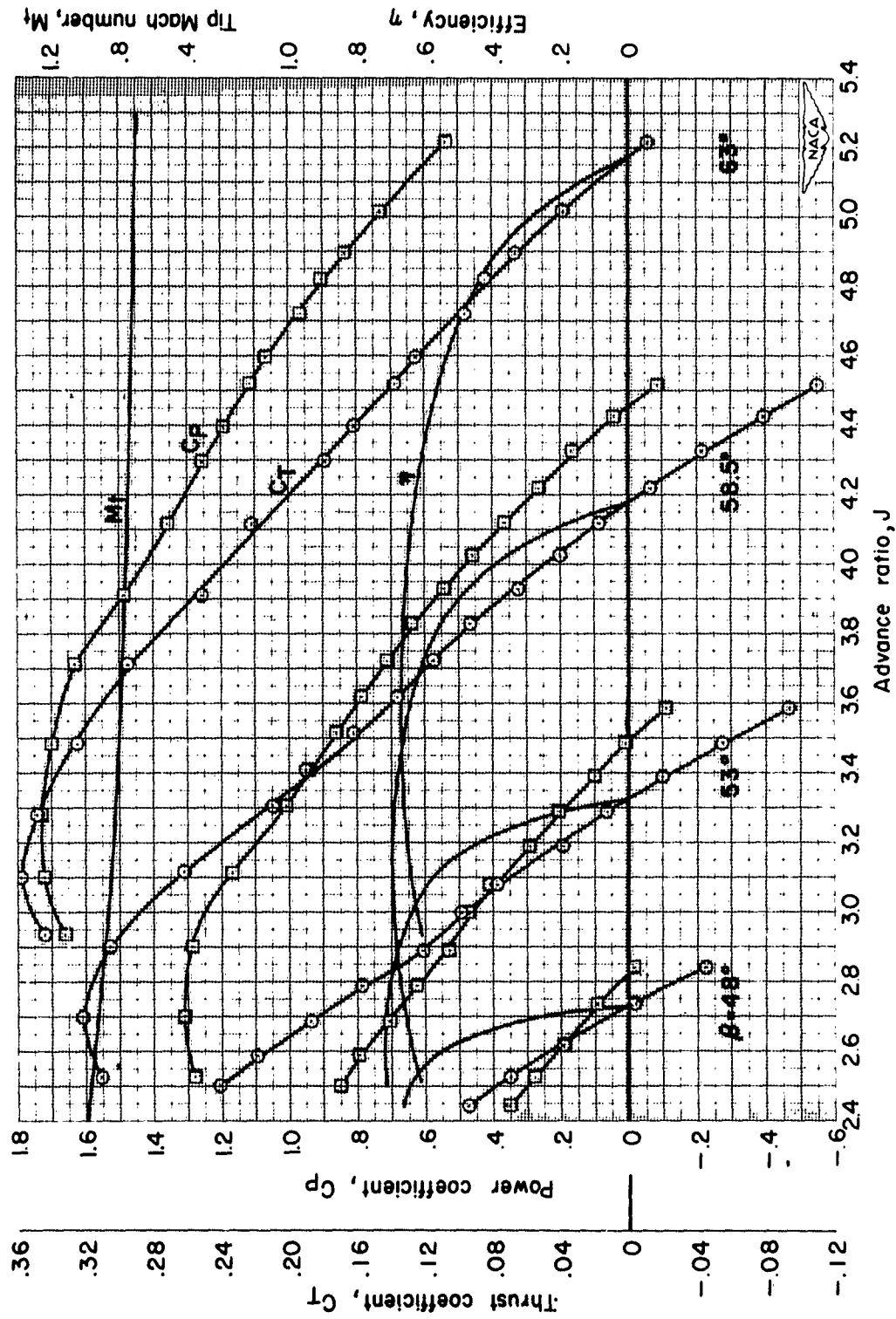

(e) $M = 0.60$

Figure 9.- Continued.

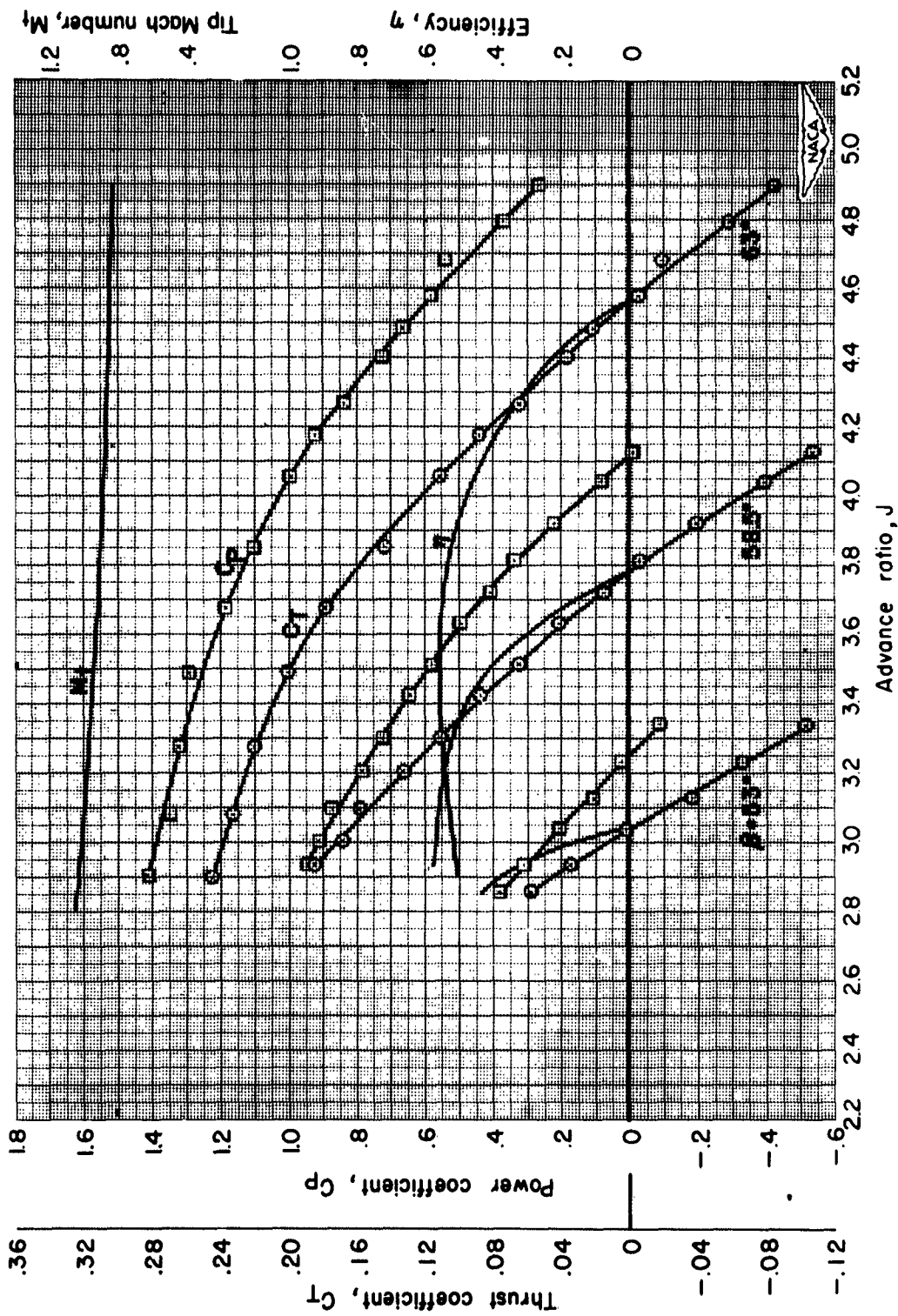

(f) $M = 0.70$

Figure 9.- Continued.

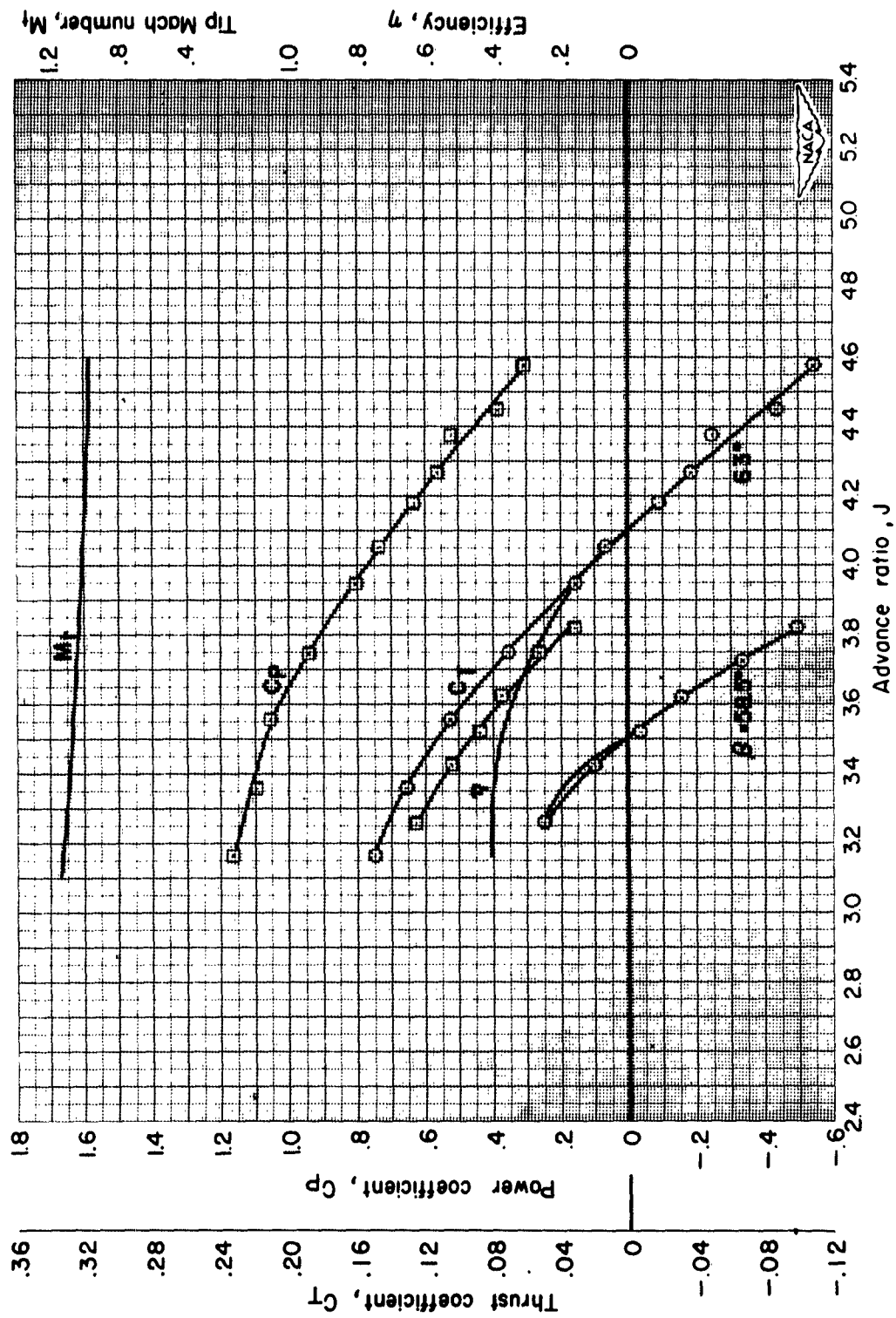

(β) $M = 0.80$

Figure 9.- Concluded.

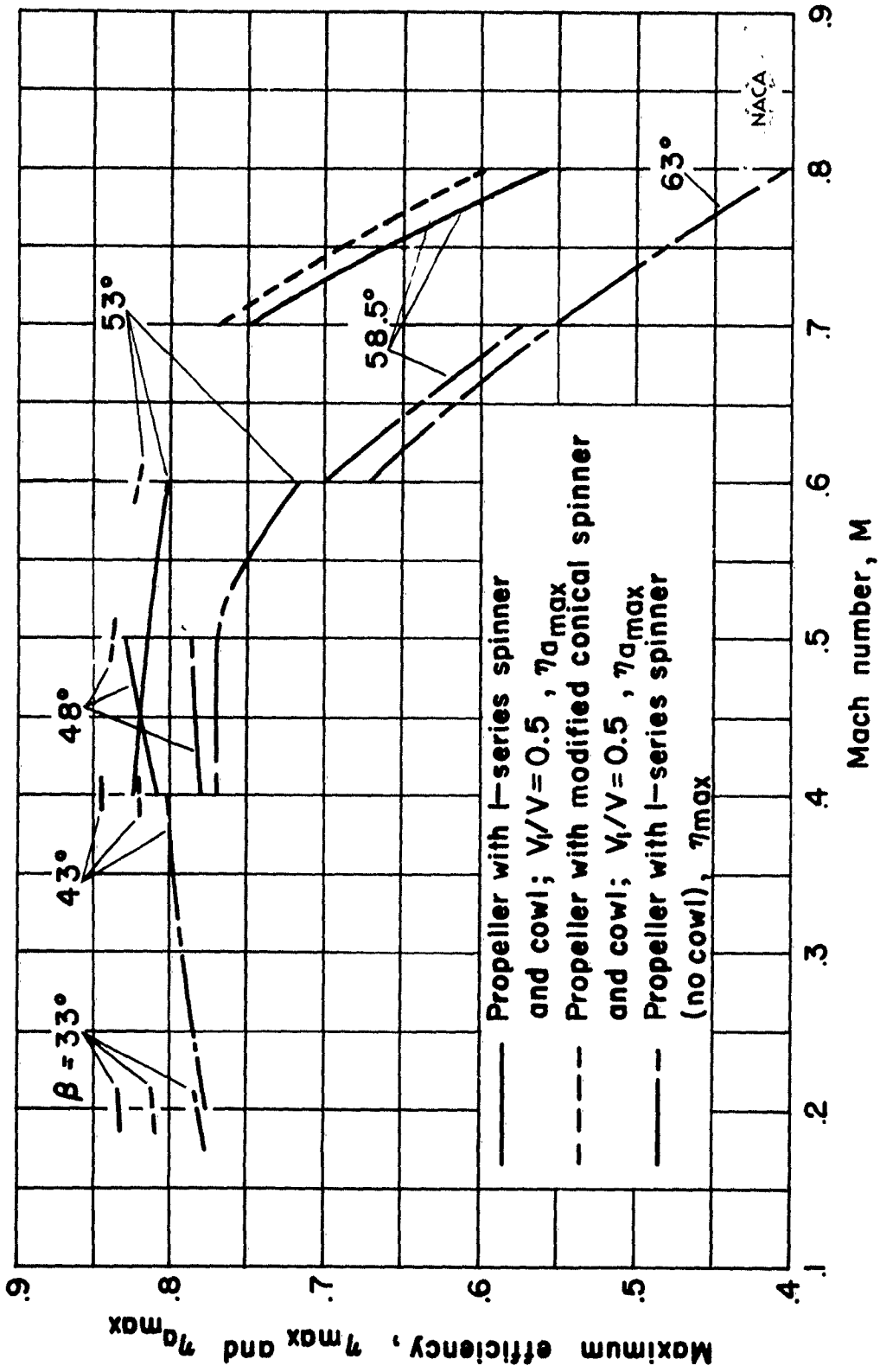
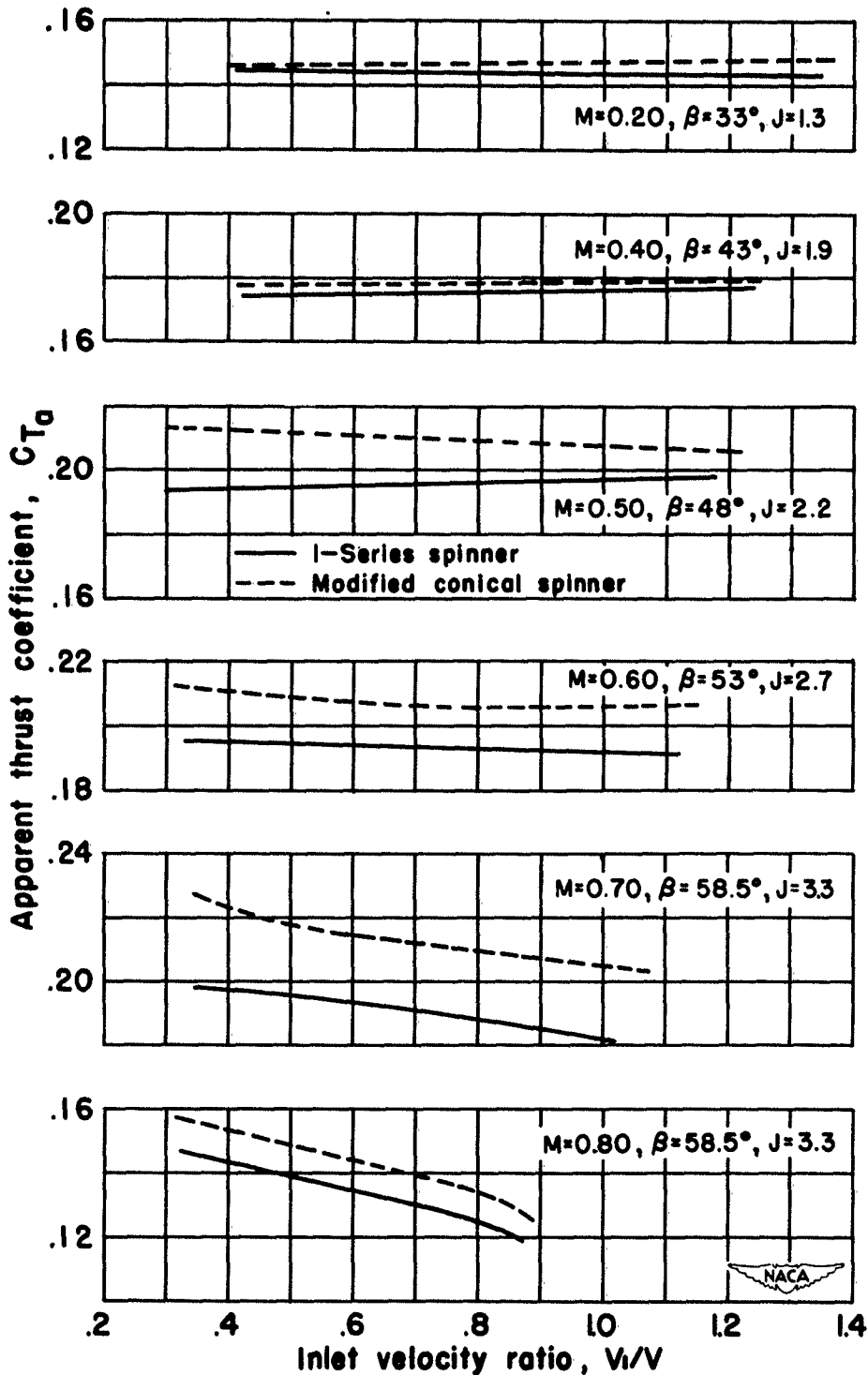
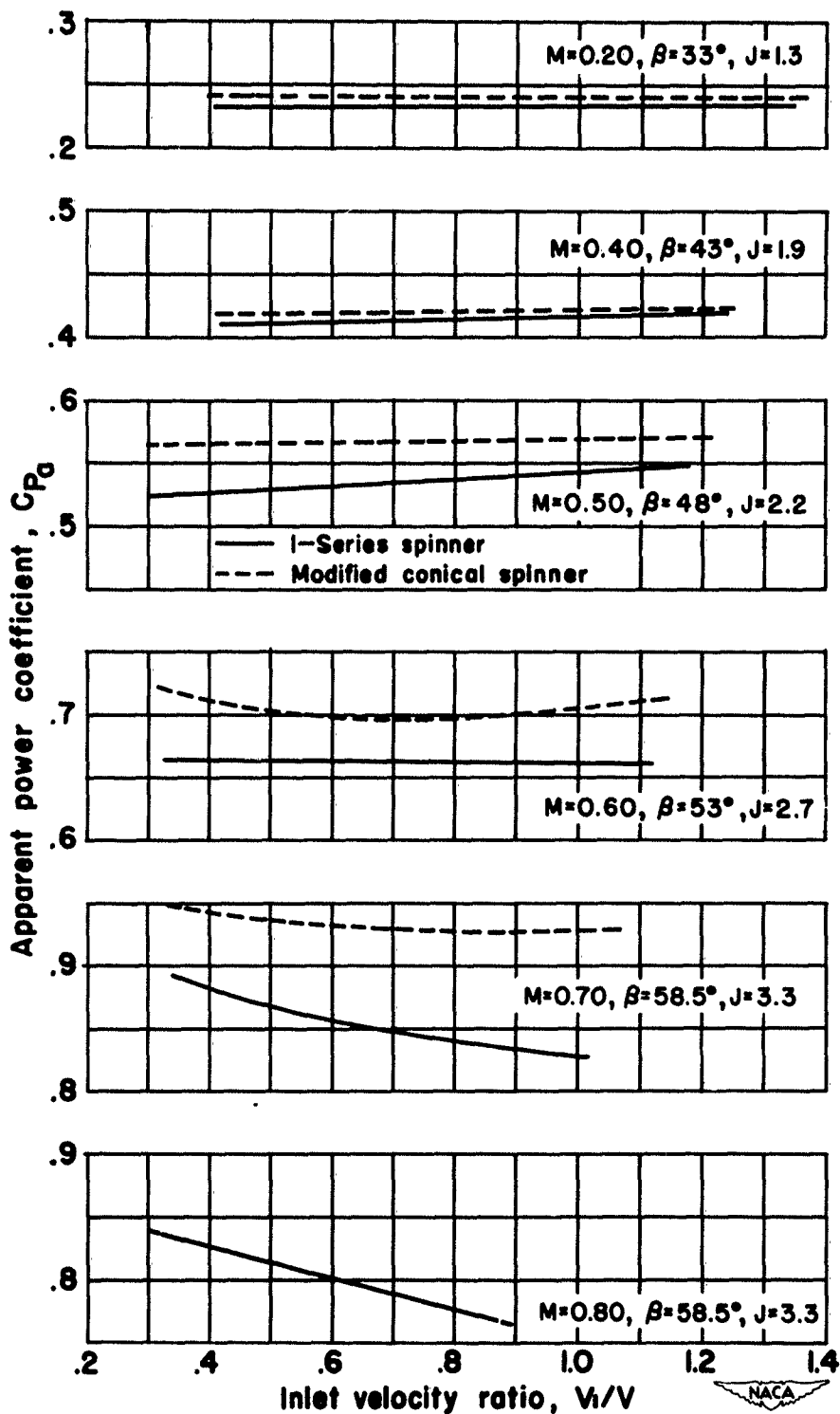

Figure 10.- Comparison of the maximum efficiency of the propeller with and without the cowl.



(a) C_{T_a} vs. V_1/V

Figure 11.- Typical effect of inlet velocity ratio on the apparent thrust and power coefficients of the propeller.



(b) C_{Pa} vs. V_1/V

Figure 11.- Concluded.

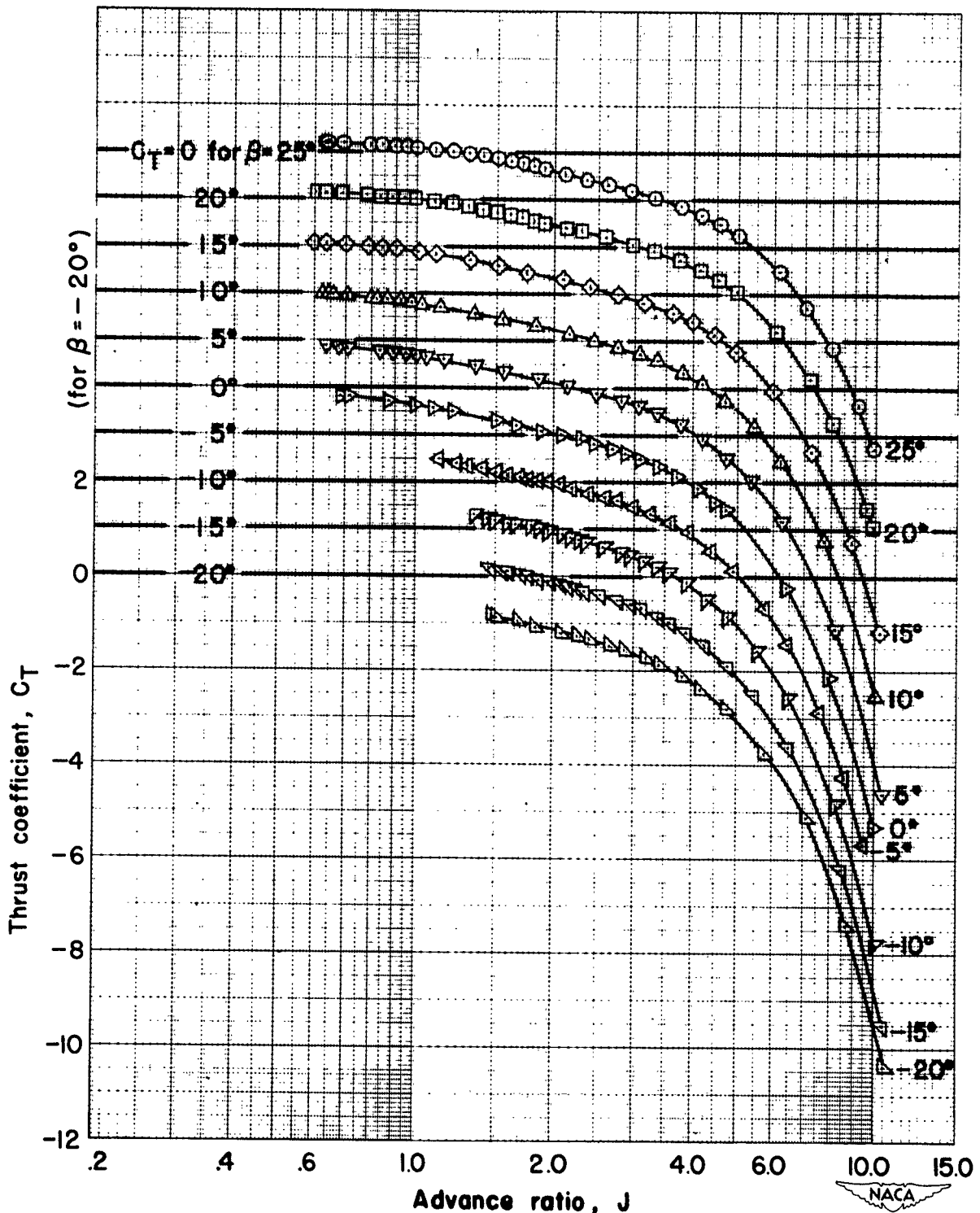

(a) $M = 0.15$

Figure 12.- Negative thrust coefficients for the isolated propeller-spinner combination.

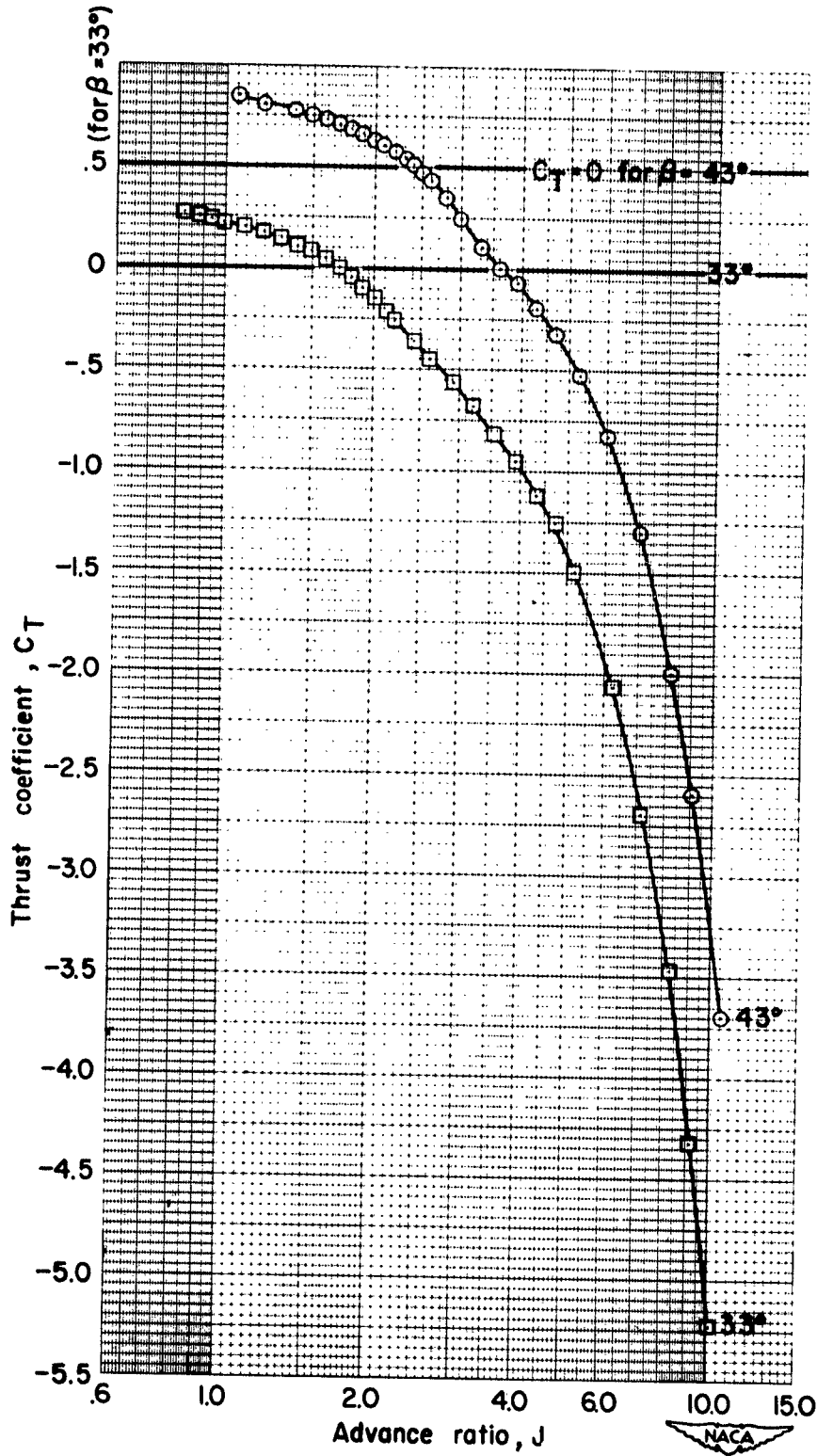

(b) $M = 0.20$

Figure 12.- Continued.

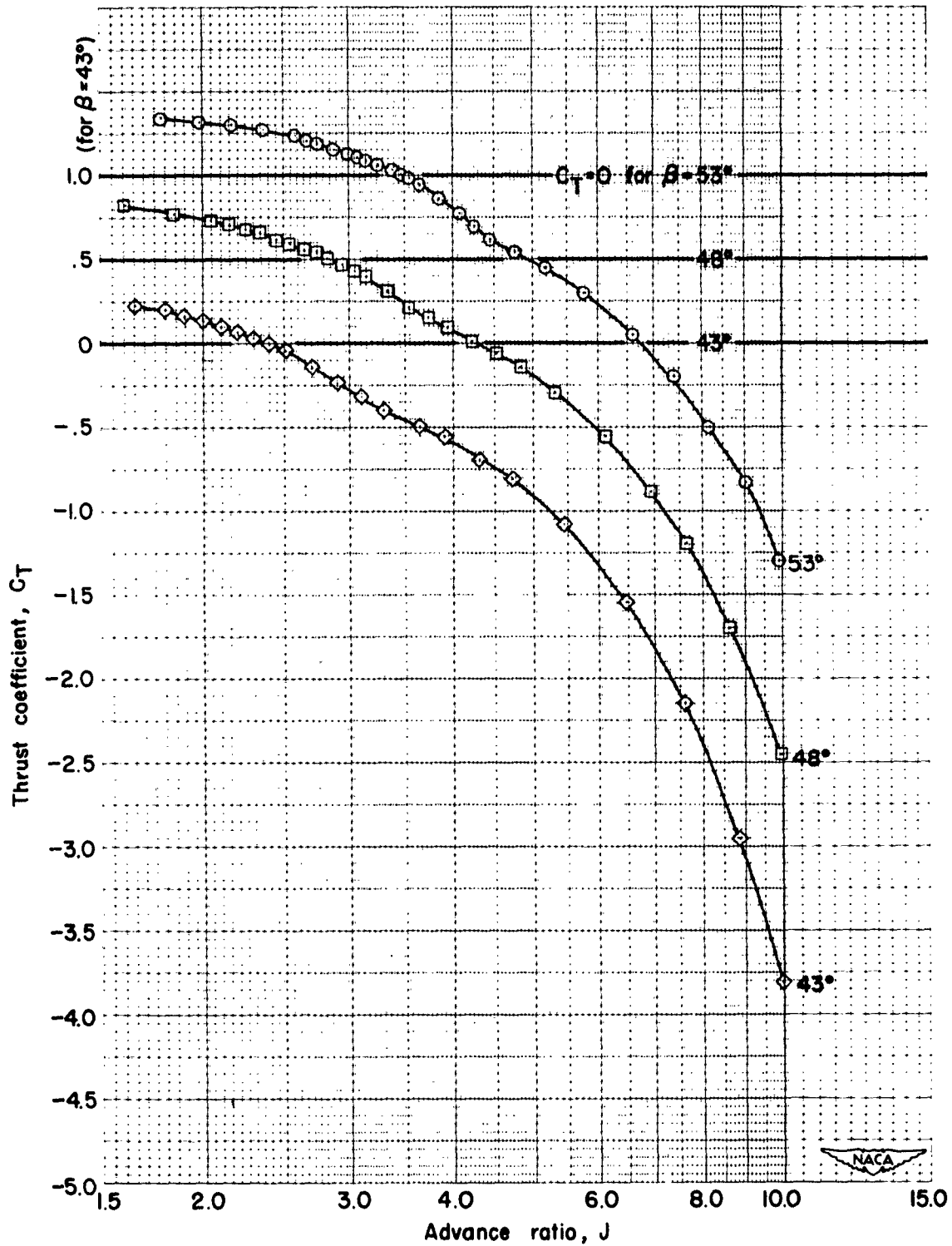

(c) $M = 0.40$

Figure 12.- Continued.

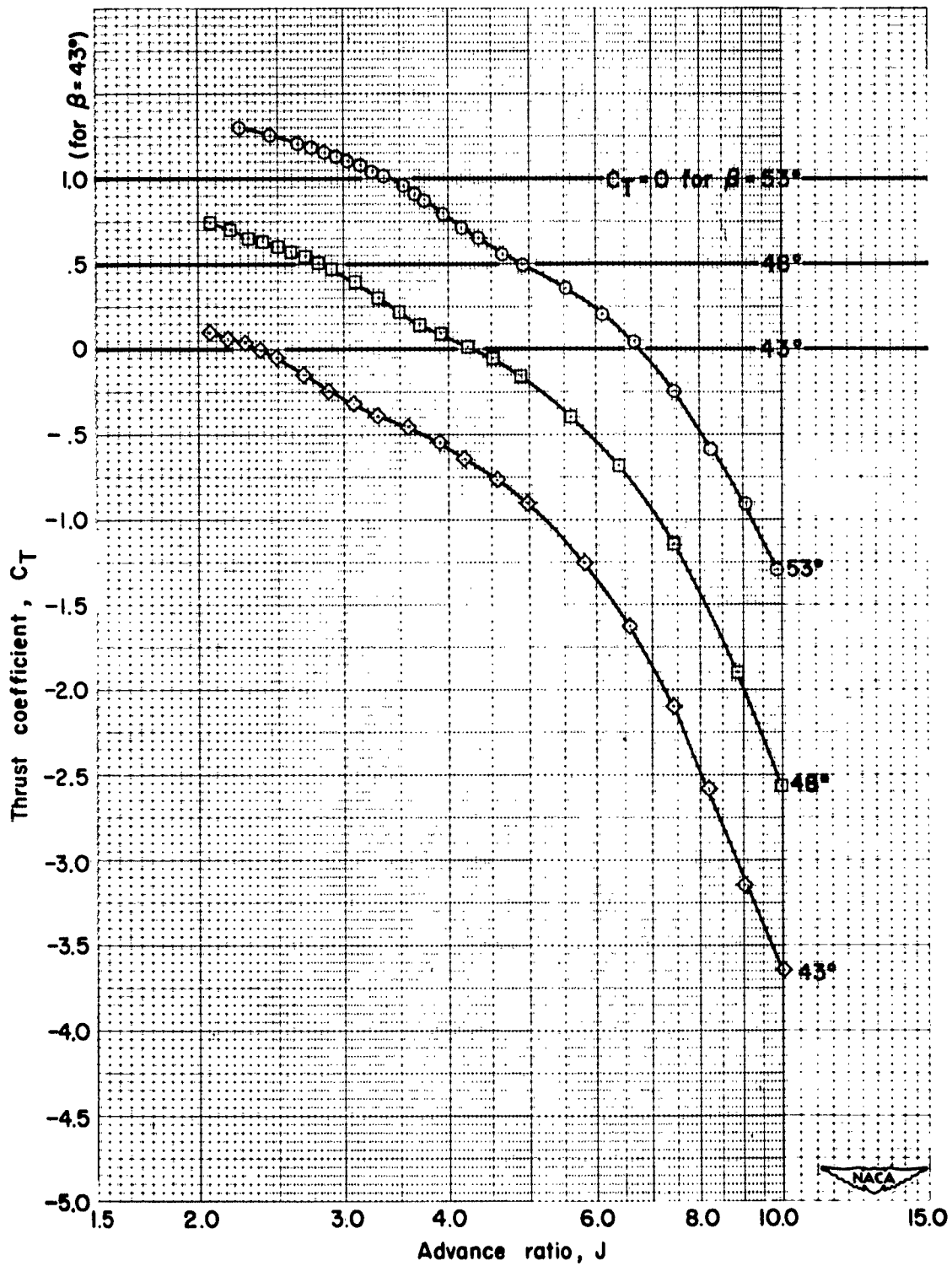

(d) $M = 0.50$

Figure 12.- Continued.

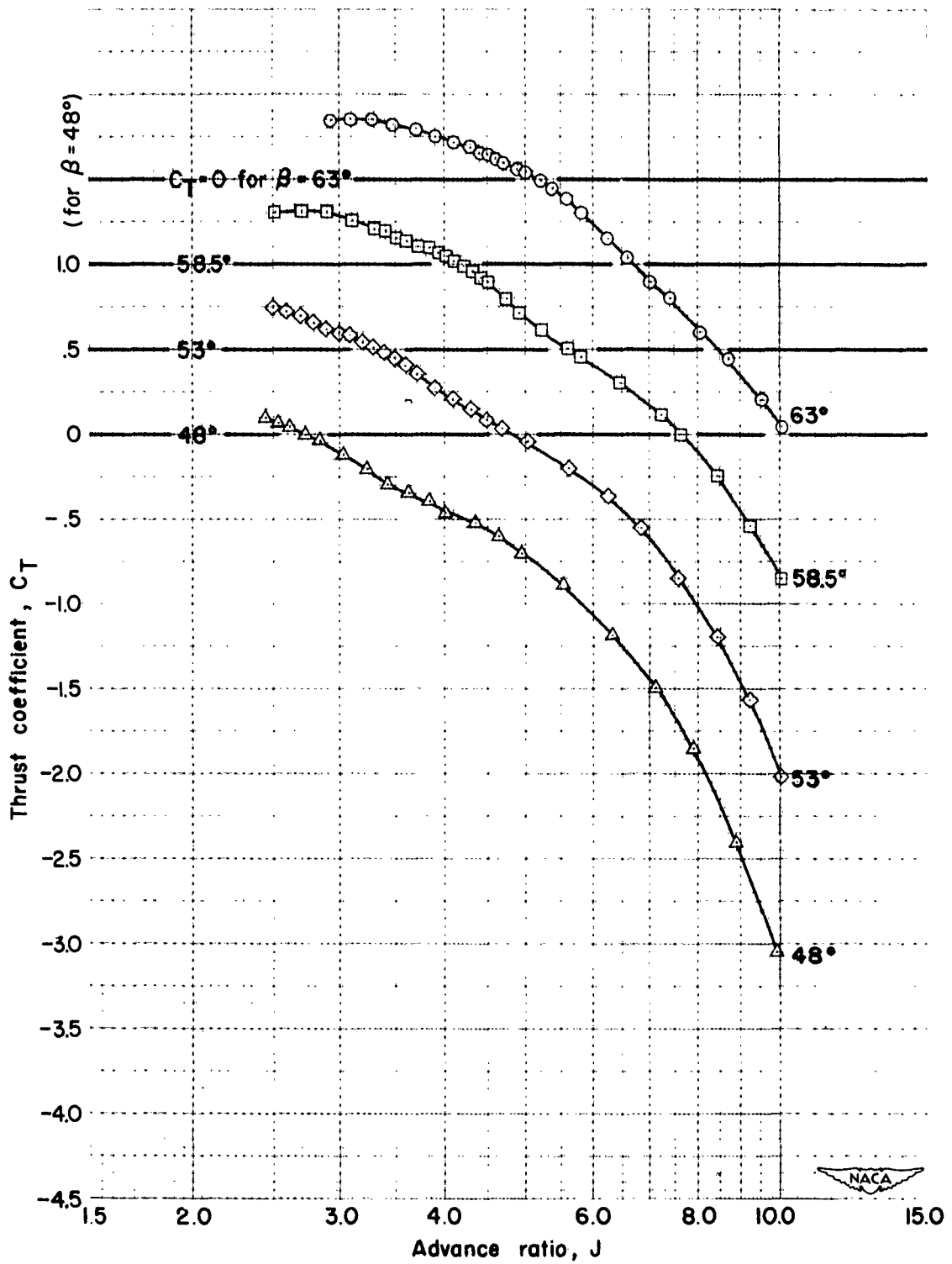

(e) $M = 0.60$

Figure 12.- Continued.

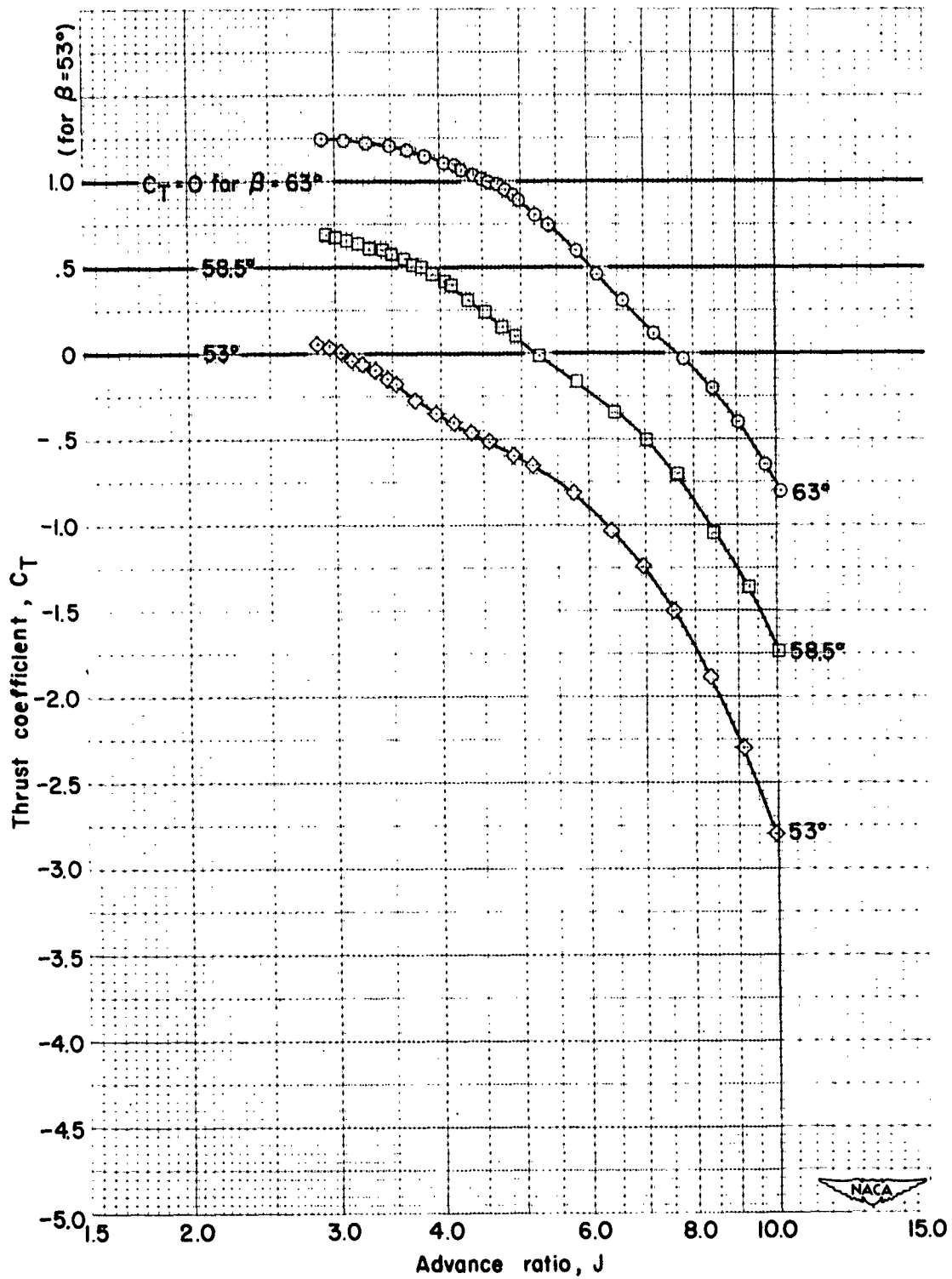

(f) $M = 0.70$

Figure 12.- Continued.

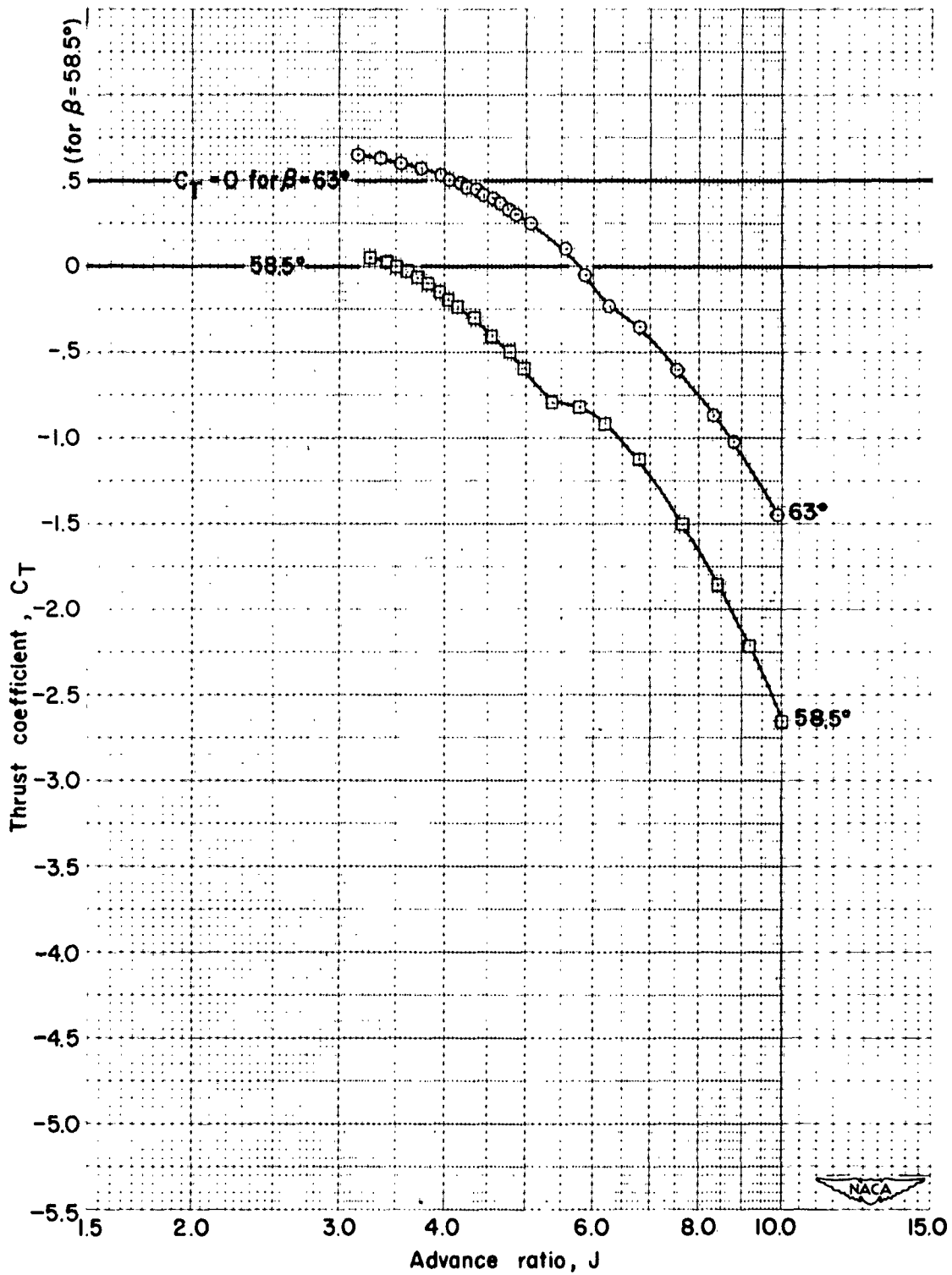

(g) $M = 0.80$

Figure 12.- Concluded.

(a) $M = 0.15$

Figure 13.- Power coefficients for the isolated propeller-spinner combination in negative thrust.



(b) $M = 0.20$

Figure 13.- Continued.

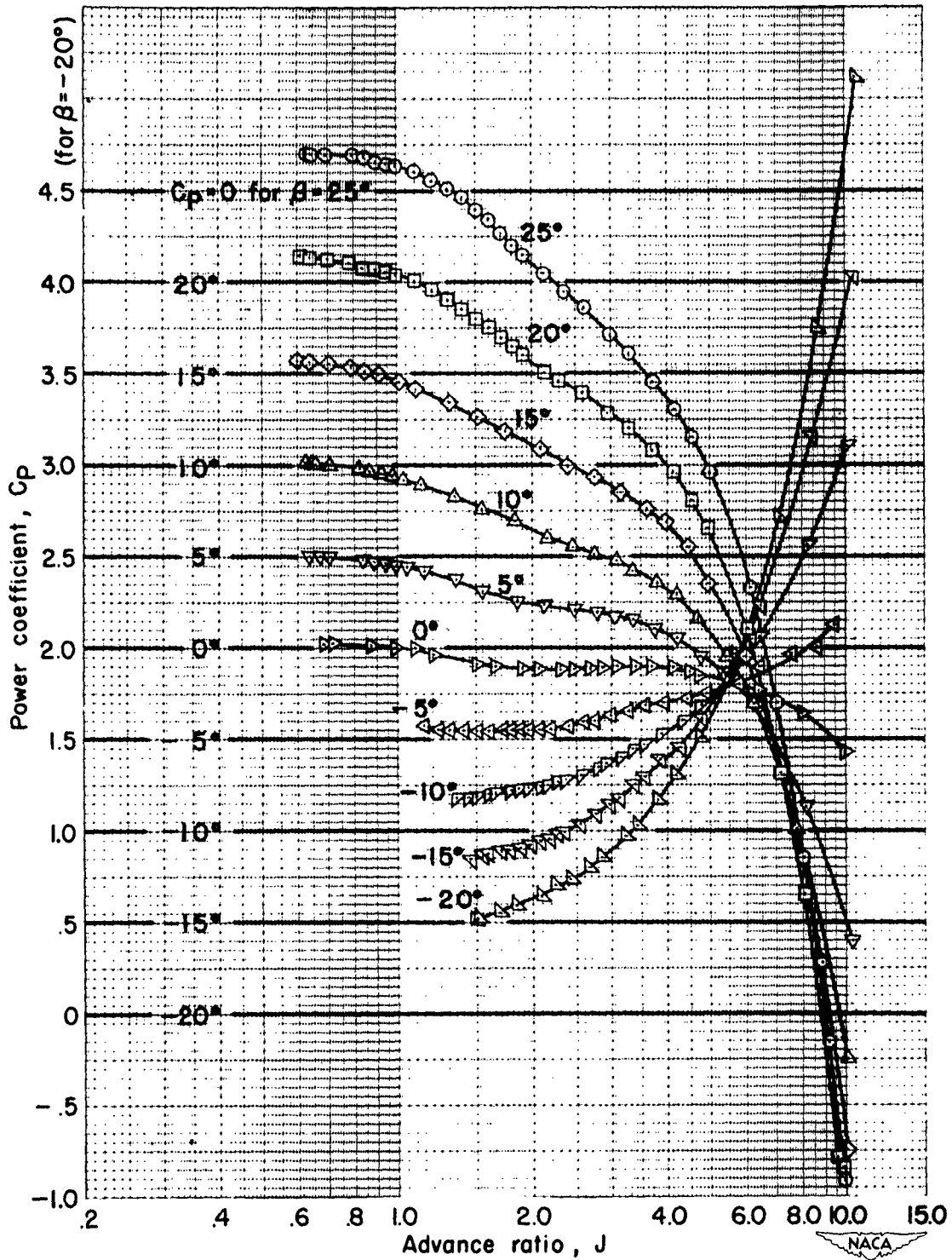
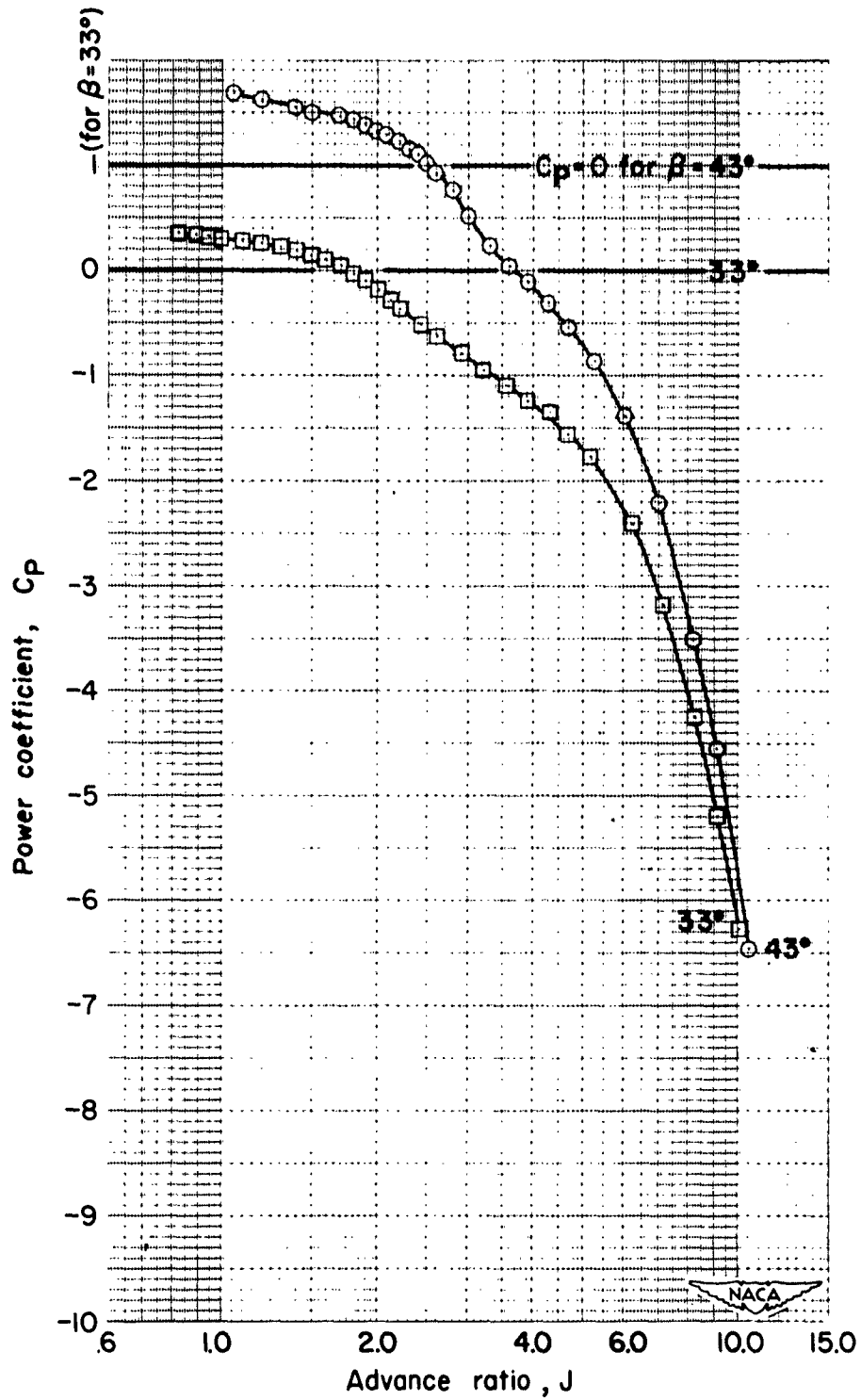
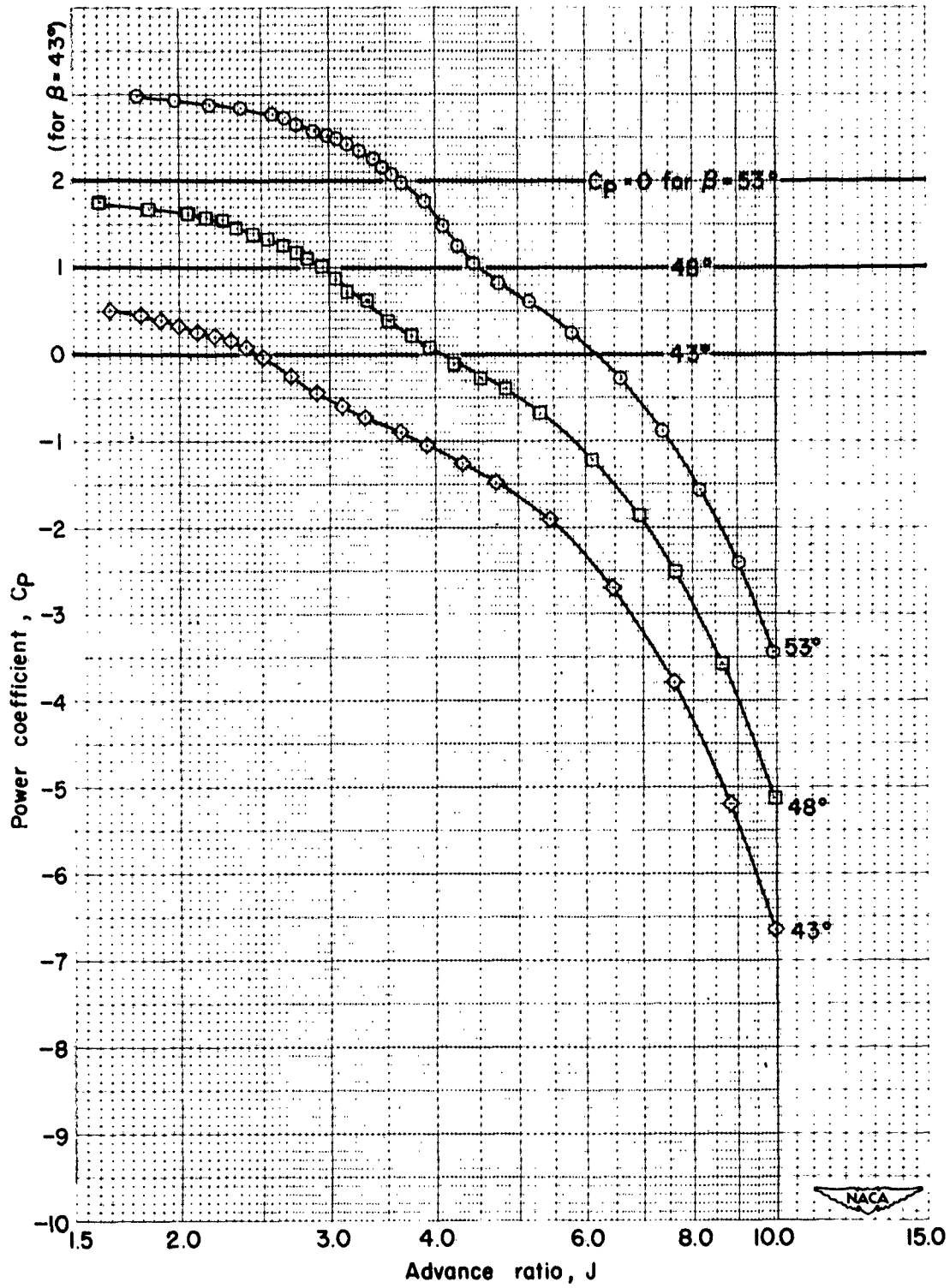

(c) $M = 0.40$

Figure 13.- Continued.

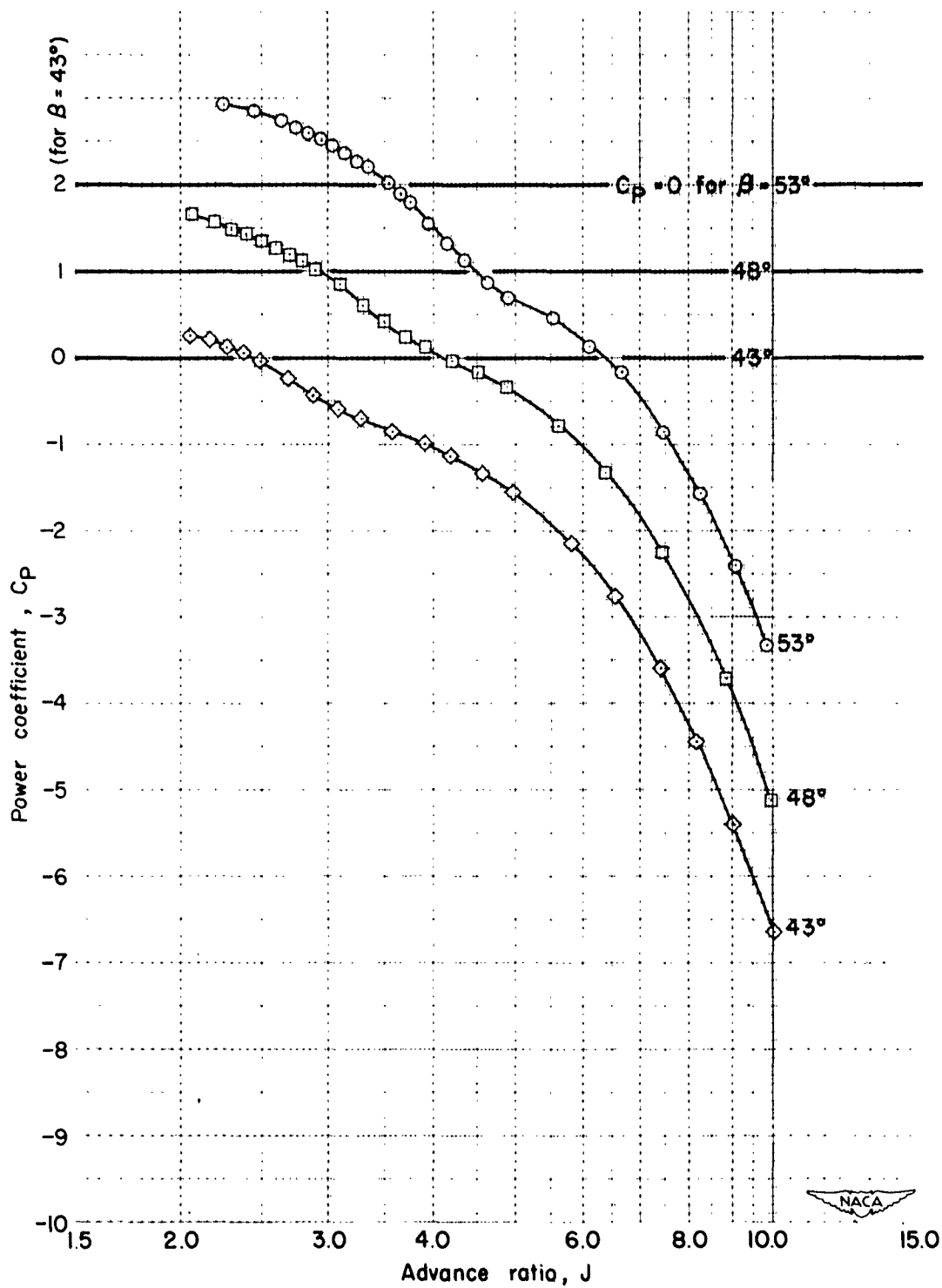

(d) $M = 0.50$

Figure 13.- Continued.

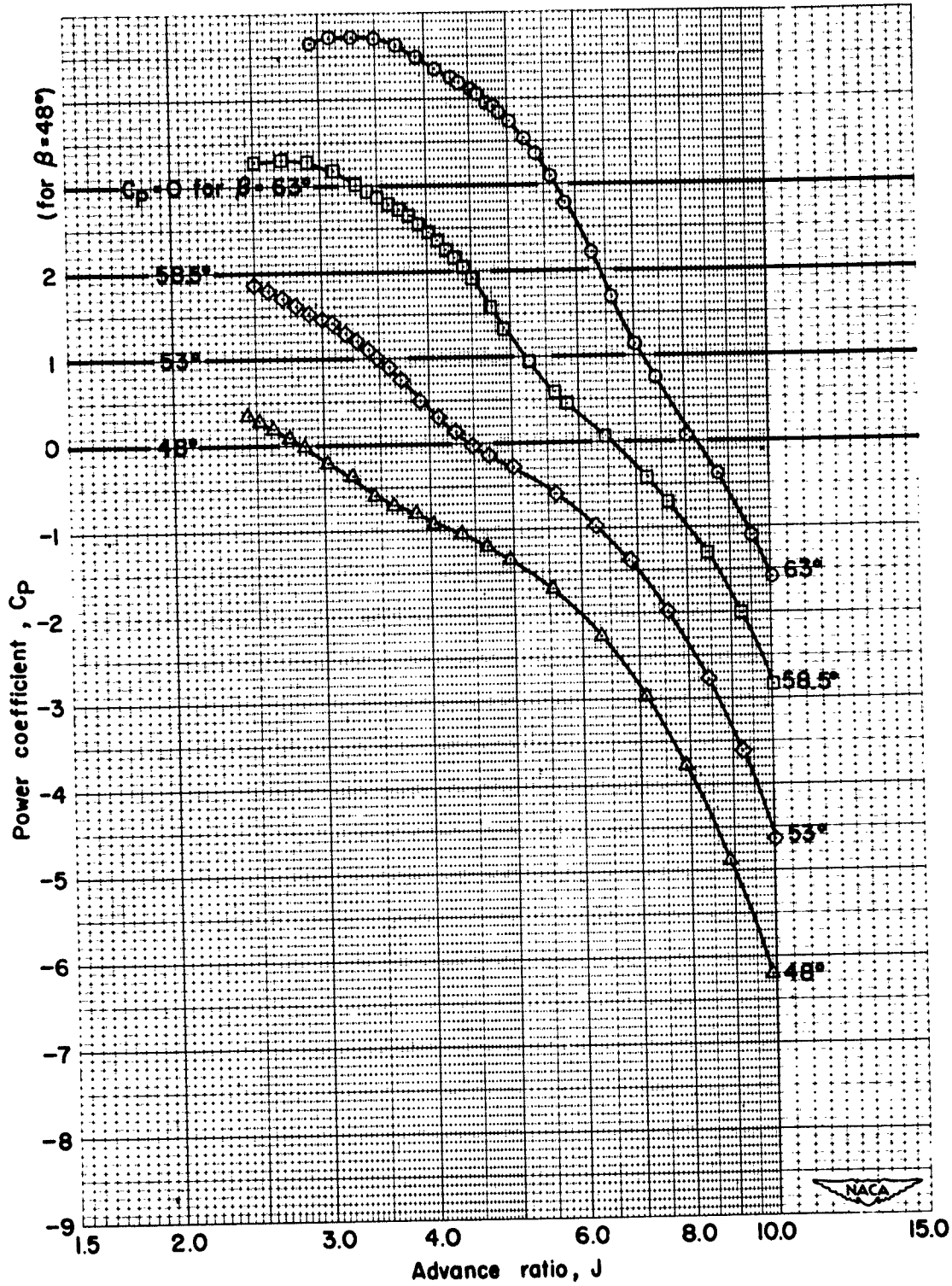

(e) $M = 0.60$

Figure 13.- Continued.

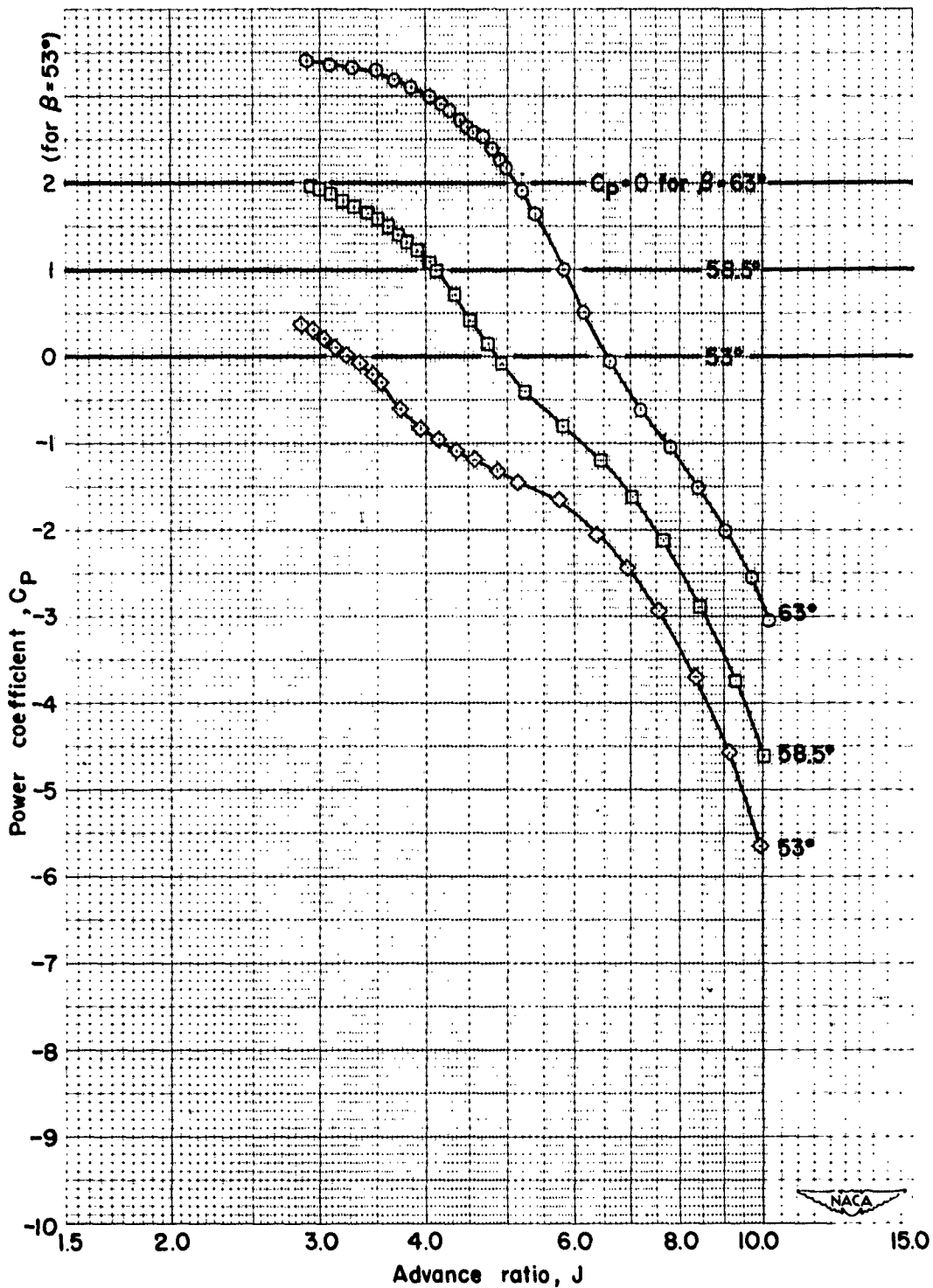

(f) $M = 0.70$

Figure 13.- Continued.

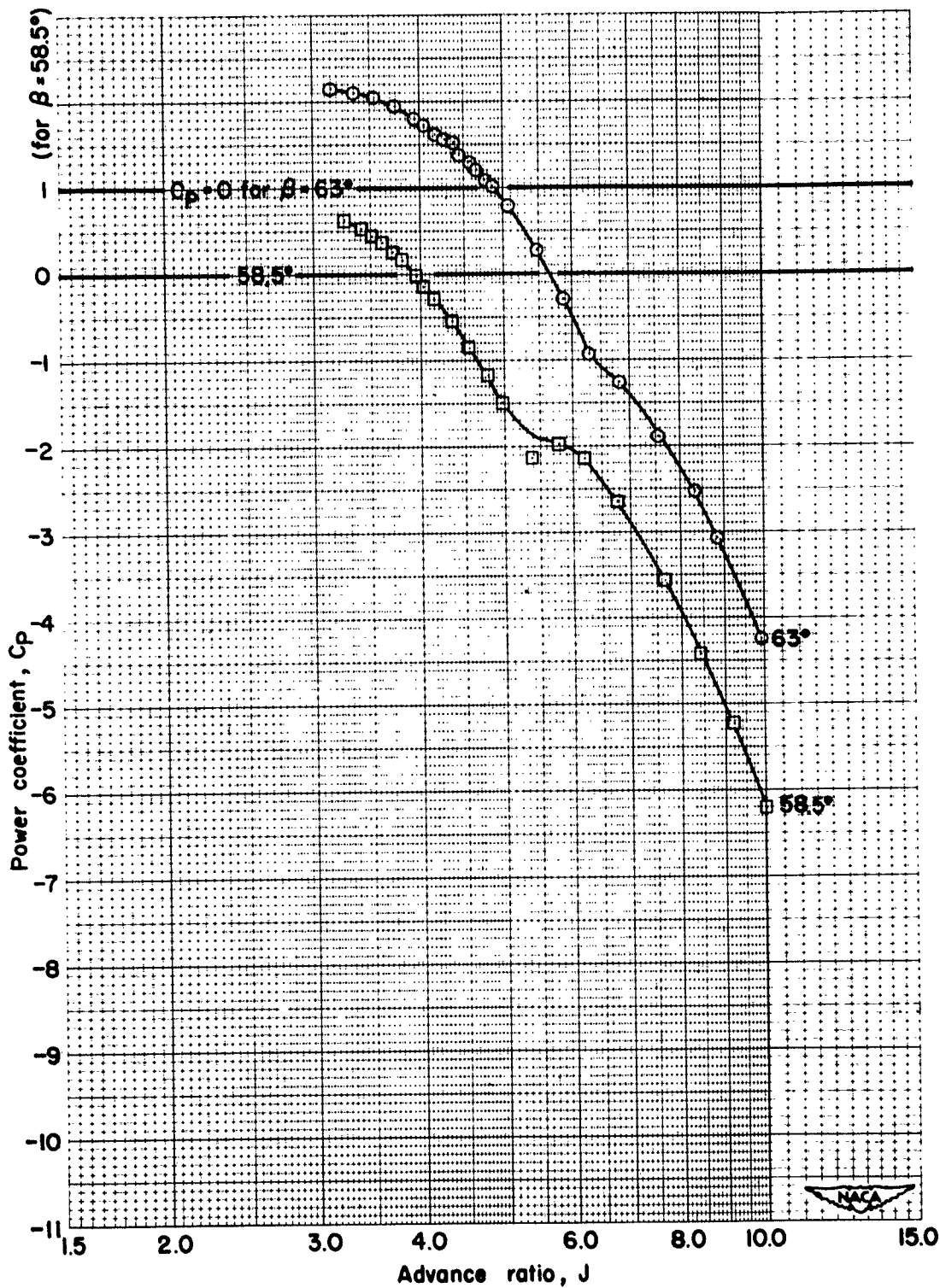

(g) $M = 0.80$

Figure 13.- Concluded.

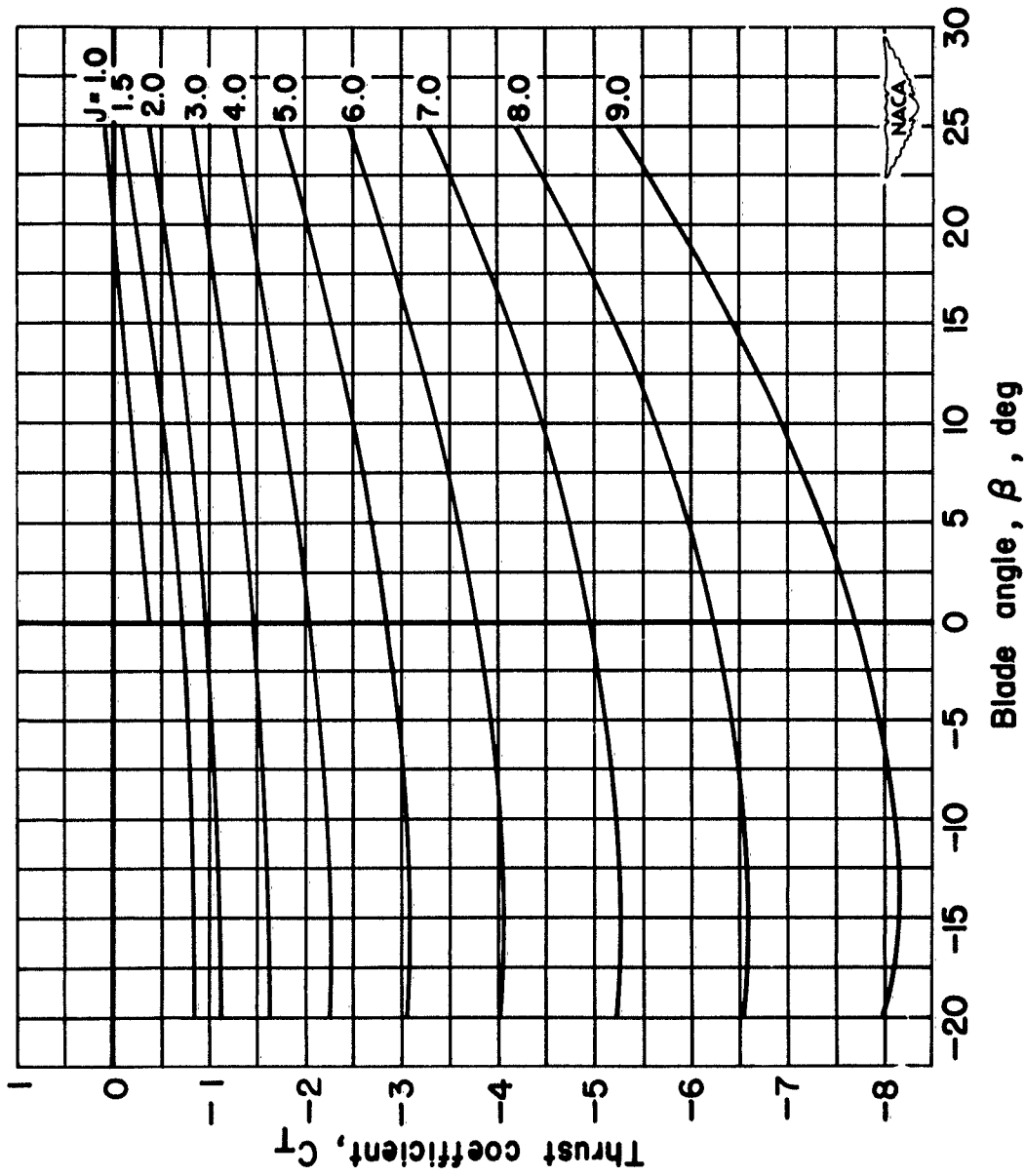

(a) $M = 0.15$

Figure 14.- The effect of blade angle on the negative-thrust characteristics of the propeller.

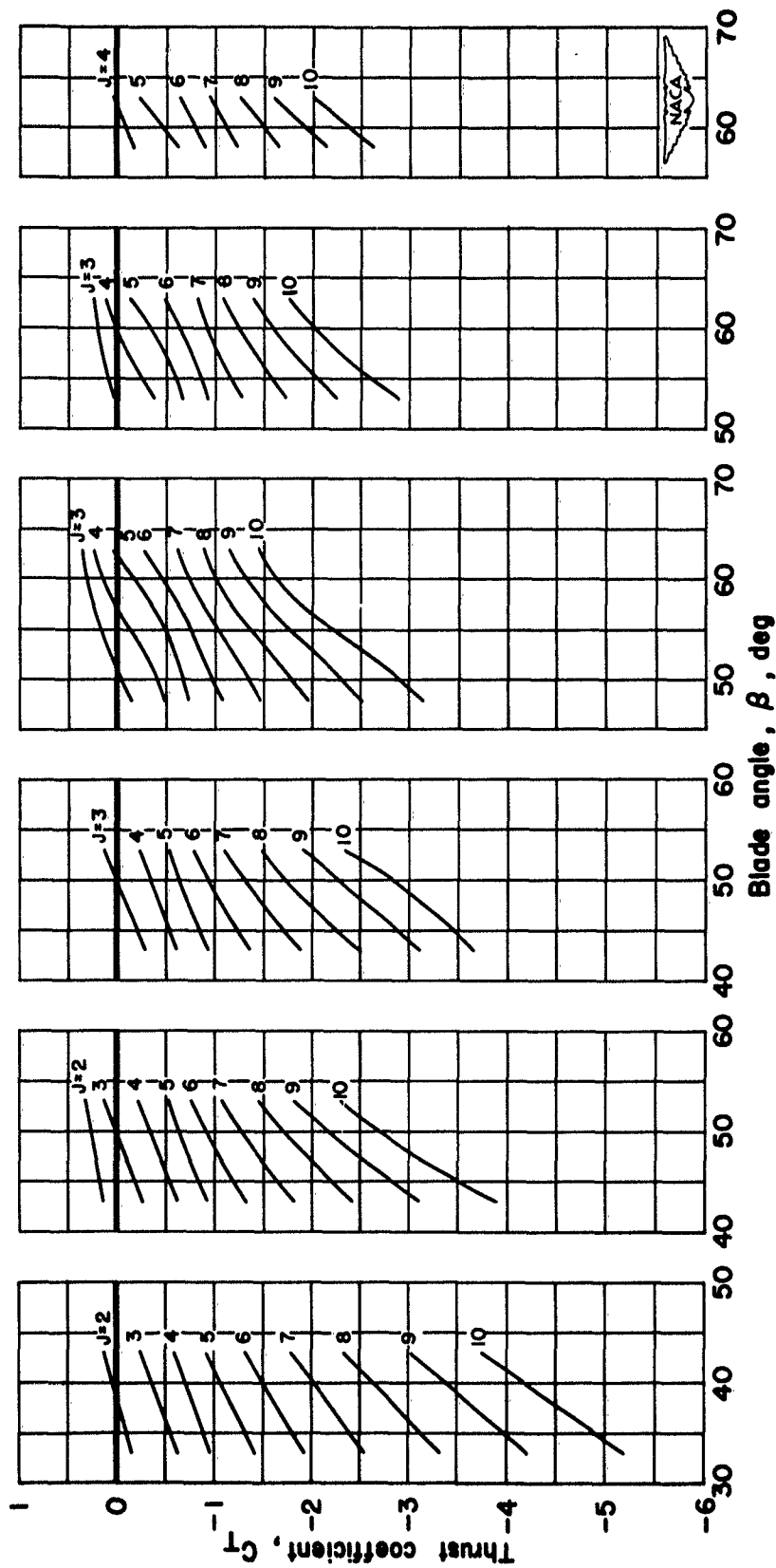

(b) $M = 0.20$ (c) $M = 0.40$ (d) $M = 0.50$ (e) $M = 0.60$ (f) $M = 0.70$ (g) $M = 0.80$

Figure 14.- Concluded.

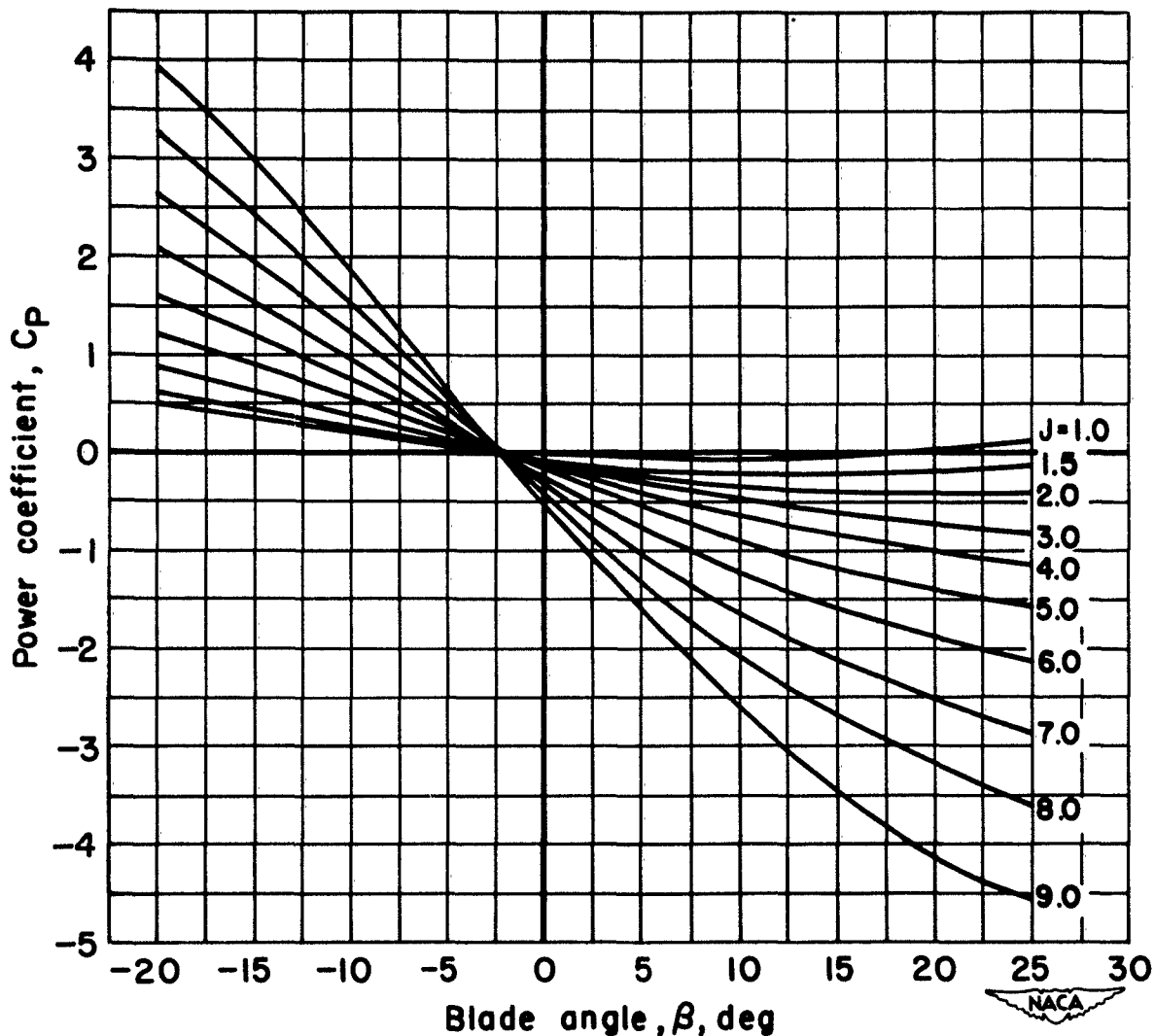

(a) $M = 0.15$

Figure 15.- The effect of blade angle on the power coefficients for the propeller in negative thrust.

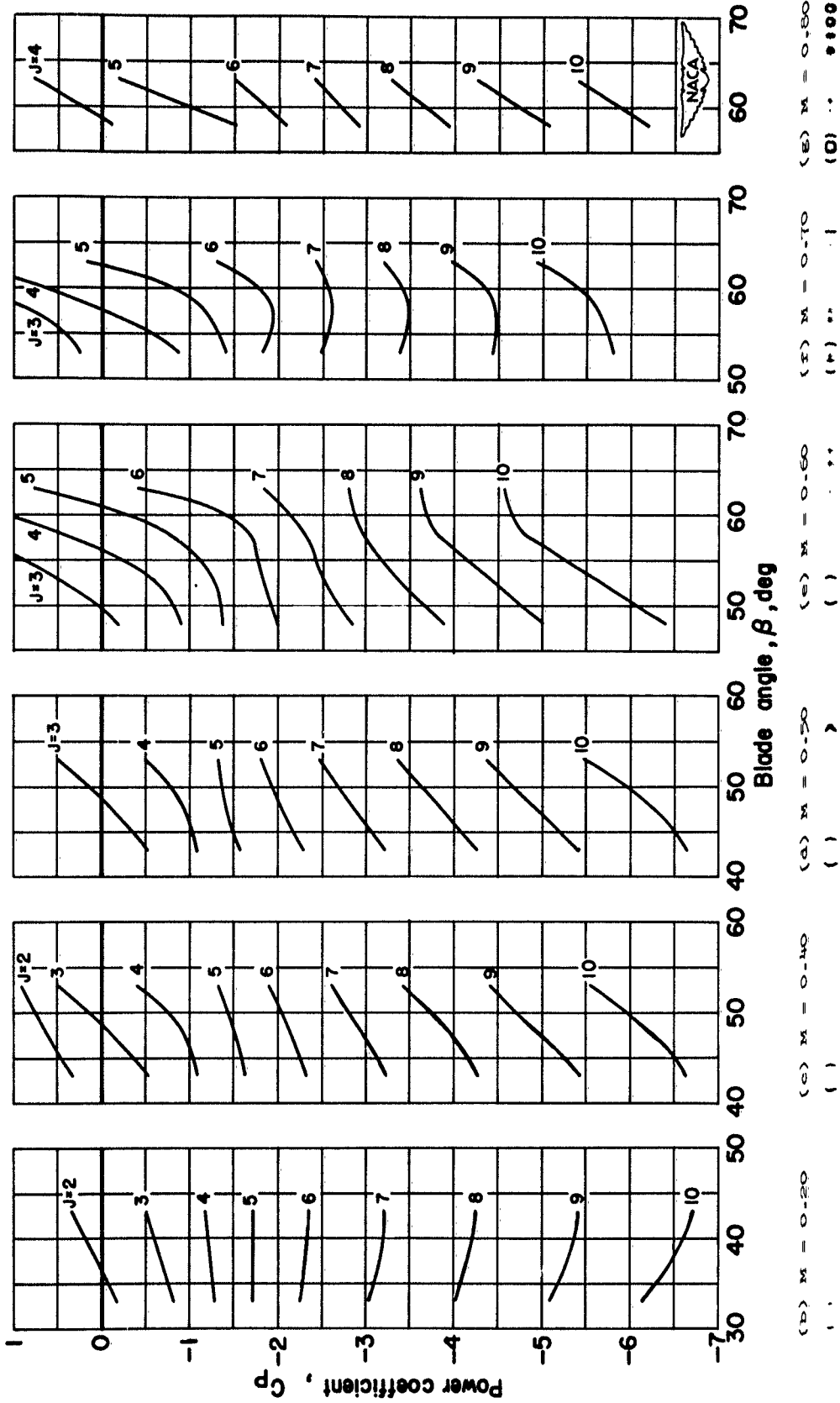
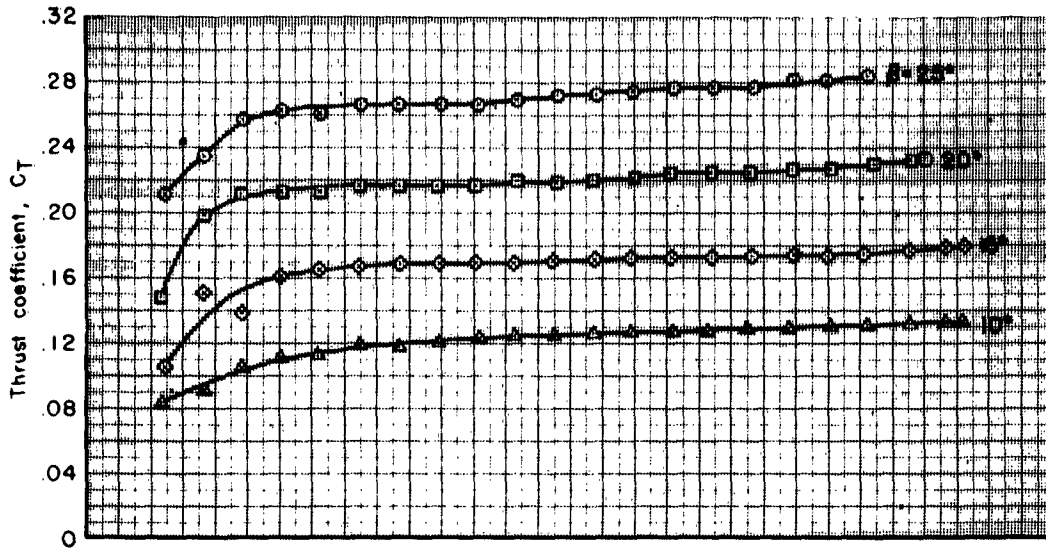
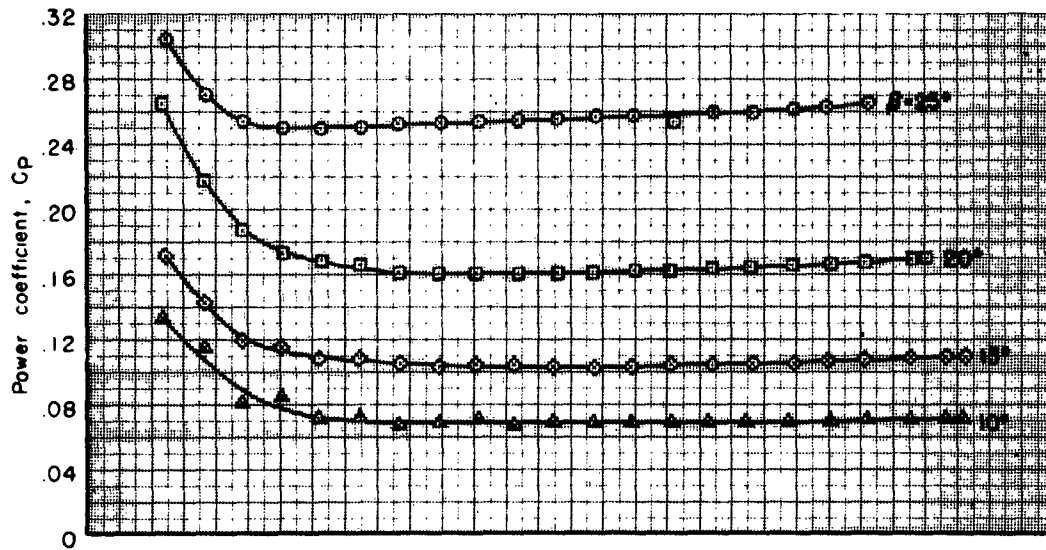

Figure 15.- Concluded.



(a) C_T vs. nD



(b) C_P vs. nD

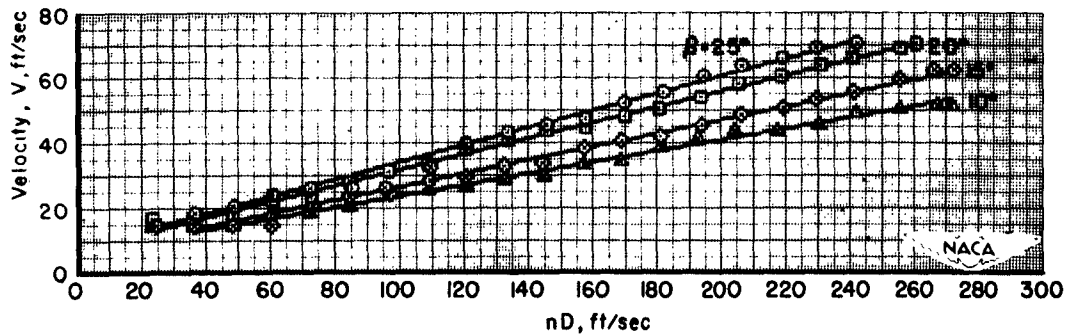

(c) V vs. nD

Figure 16.- Characteristics of the isolated propeller-spinner combination at near static conditions.

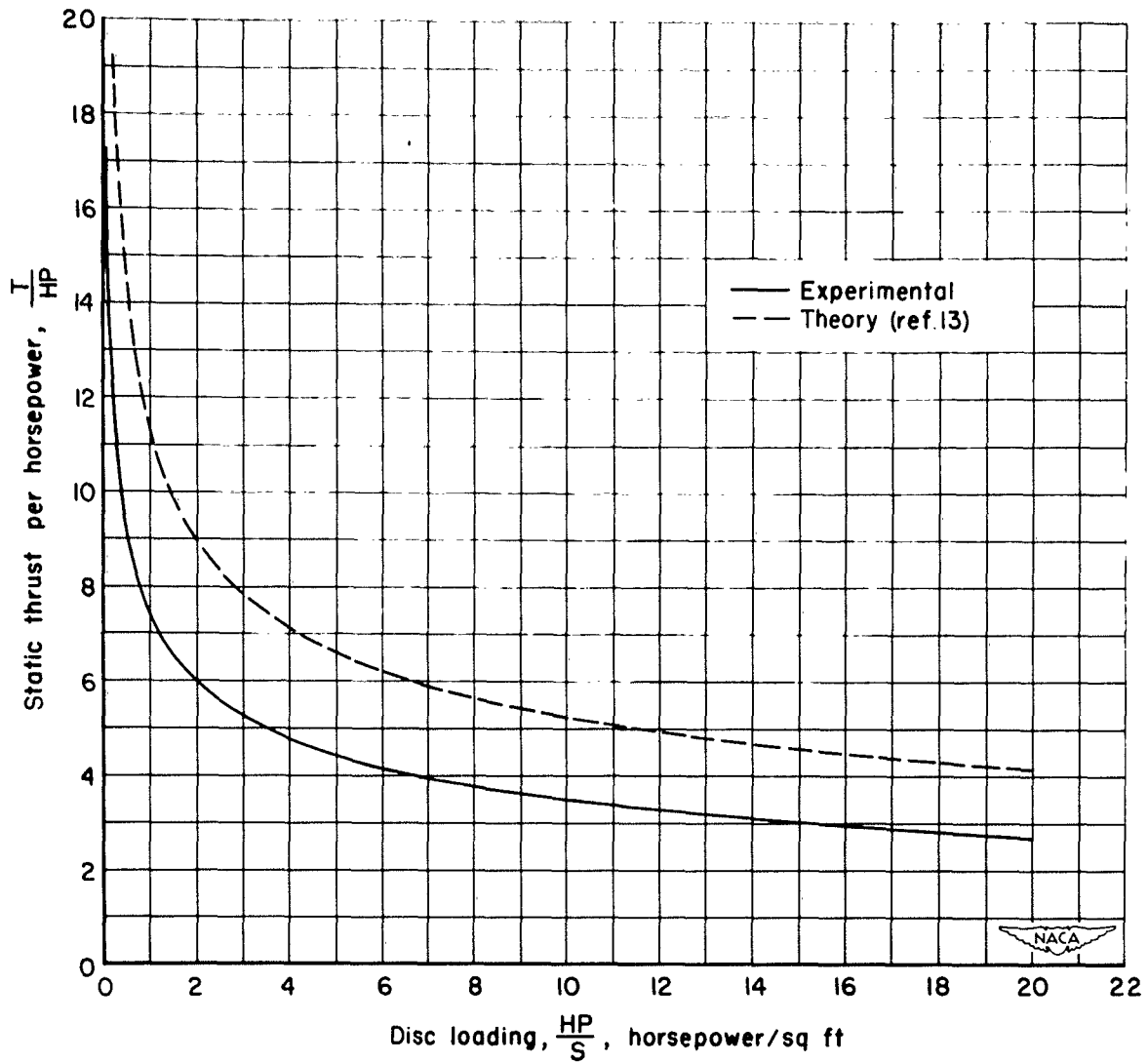

Figure 17.- Comparison with theory of the variation of sea-level static thrust per horsepower with power disc loading for the isolated propeller-spinner combination.

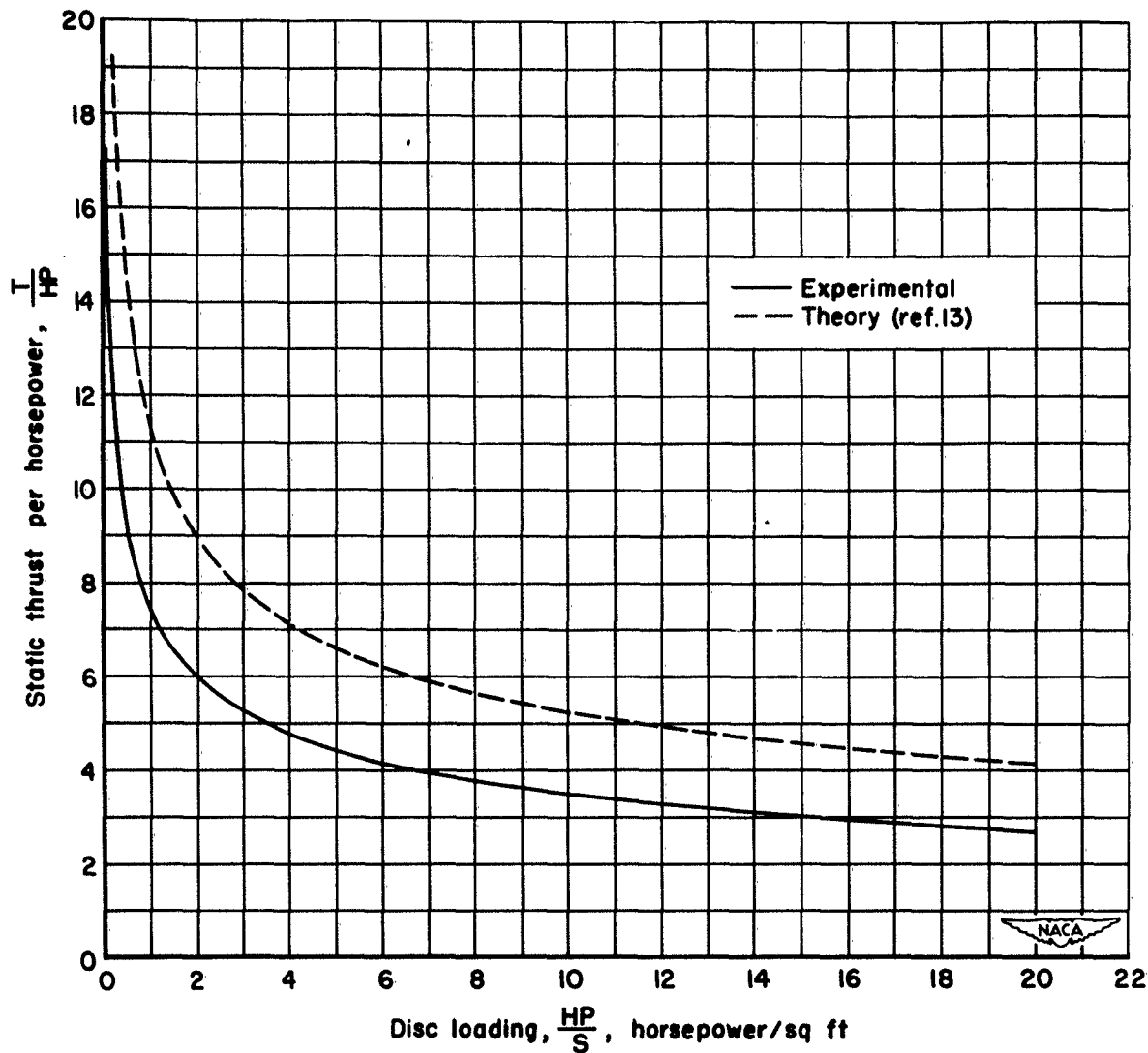

Figure 17.- Comparison with theory of the variation of sea-level static thrust per horsepower with power disc loading for the isolated propeller-spinner combination.

SUBJECT HEADINGS

Air Inlets - Propeller-Spinner-Cowl	1.4.1.1.1
Mach Number Effects - Propellers	1.5.2.5
Interference of Bodies .- Propellers	1.5.2.8
Propellers - Designated Types	1.5.3
Propeller-Spinner-Cowl Combinations	1.5.7

ABSTRACT

This report presents the aerodynamic characteristics of a three-blade propeller (designated NACA 3.638-(675)(057)-0572) at Mach numbers up to 0.80. Tests were made at positive thrust for the propeller with a 1-series spinner and a modified conical spinner operating in the presence of an NACA 1-series D-type cowl. Tests were also conducted for the isolated propeller-spinner combination operating at positive thrust, negative thrust, and at near static conditions. Included are the results of air-stream surveys of the local velocities in the plane of the propeller.