

UNCLASSIFIED

AD NUMBER
AD029527
NEW LIMITATION CHANGE
TO Approved for public release, distribution unlimited
FROM Distribution authorized to DoD only; Foreign Government Information; AUG 1952. Other requests shall be referred to British Embassy, 3100 Massachusetts Avenue, NW, Washington, DC 20008.
AUTHORITY
DSTL, DEFE 15/330, 30 Apr 2008

THIS PAGE IS UNCLASSIFIED

# Armed Services Technical Information Agency

Because of our limited supply, you are requested to return this copy **WHEN IT HAS SERVED YOUR PURPOSE** so that it may be made available to other requesters. Your cooperation will be appreciated.

# AD

# 29527

**NOTICE: WHEN GOVERNMENT OR OTHER DRAWINGS, SPECIFICATIONS OR OTHER DATA ARE USED FOR ANY PURPOSE OTHER THAN IN CONNECTION WITH A DEFINITELY RELATED GOVERNMENT PROCUREMENT OPERATION, THE U. S. GOVERNMENT THEREBY INCURS NO RESPONSIBILITY, NOR ANY OBLIGATION WHATSOEVER; AND THE FACT THAT THE GOVERNMENT MAY HAVE FORMULATED, FURNISHED, OR IN ANY WAY SUPPLIED THE SAID DRAWINGS, SPECIFICATIONS, OR OTHER DATA IS NOT TO BE REGARDED BY IMPLICATION OR OTHERWISE AS IN ANY MANNER LICENSING THE HOLDER OR ANY OTHER PERSON OR CORPORATION, OR CONVEYING ANY RIGHTS OR PERMISSION TO MANUFACTURE, USE OR SELL ANY PATENTED INVENTION THAT MAY IN ANY WAY BE RELATED THERETO.**

Reproduced by  
**DOCUMENT SERVICE CENTER**  
KNOTT BUILDING, DAYTON, 2, OHIO

# UNCLASSIFIED

AD NO. 29-571  
ASTIA FILE COPY 7581

ARMAMENT DESIGN ESTABLISHMENT  
MINISTRY OF SUPPLY

THE PRESSURE DISTRIBUTION IN LIQUIDS IN LAMINAR  
SHEARING MOTION AND COMPARISON WITH  
PREDICTIONS FROM VARIOUS THEORIES

J. E. ROBERTS

THE INFORMATION IN THIS REPORT IS  
DISCLOSED IN CONFIDENCE TO THE  
RECIPIENT GOVERNMENT ON CONDITION  
THAT IT IS NOT REPRODUCED OUTSIDE  
GOVERNMENT DEPARTMENTS WITHOUT THE  
PRIOR PERMISSION OF THE MINISTRY OF  
SUPPLY.

ARMAMENT DESIGN ESTABLISHMENT

A.D.E. 13/52

THE PRESSURE DISTRIBUTION IN LIQUIDS IN LAMINAR SHEARING MOTION  
AND COMPARISON WITH PREDICTIONS FROM VARIOUS THEORIES

J. E. Roberts, B.Sc., A.Inst.P.

Recommended for publication

*L. V. Thomas*

L. V. Thomas D.4.

Approved for publication

*A. P. Wickens*

A. P. Wickens C.E.A.D.

Abstract

The pressure distributions at all points throughout the full solid angle have been determined experimentally in a liquid under torsional shearing movements.

The method, which was checked for freedom of disturbances, did not involve the use of special assumptions, so was particularly suited to give a decision between the various controversial theories of pressure distribution in Visco-elastic liquids.

It was found that one theory (Weissenberg) predicted pressure distribution in agreement with experimental results whilst the predictions of other theories showed deviations outside the limit of experimental errors.

Armament Design Establishment,  
C.T.1. Group,  
The Grange,  
Knockholt, Kent.  
Phone: Knockholt 2191.

August, 1952.

## 1. Introduction and Summary

There have been many discrepancies in the literature about the pressure distributions of liquids in laminar shearing motions. These discrepancies arose from the high sensitivity of such distributions to some disturbances, and from the insufficiency of experimental data in view of the great number and extreme complexity of the factors which control the pressure in the flowing liquid at any one point and across any one plane.

In the present investigation it was not intended to cover all types of laminar flow or all possible experimental conditions. Instead, an attempt was made to bring sharply into focus some of the controversial points and settle these as decisively as possible. For this purpose it was necessary to restrict the field of investigation and establish an experimental technique which was, within the limits of the required accuracy, free from disturbances and experimentally complete in the sense that the measurements of pressure\* taken in the liquid were sufficient to determine the pressure distribution at all points and across planes of all the various orientations round the full solid angle by applying only first principles, that is, the principles of continuity, equilibrium of forces and symmetry without introducing additional assumptions.

For an appropriate choice of restrictions of the field it had to be considered that laminar shearing motions were available in different types, such as could be produced in a liquid by a straight axial movement of one cylinder in another, or by pressing through capillaries, or by torsion, or by any other means. Each such type of motion was characterised throughout the macroscopic dimensions of the container of the liquid, by a certain flow pattern which was generally heterogeneous and curvilinear, and traced out in the liquid by the surfaces of laminar shear gliding over one another along the lines of flow at a certain rate of shear. The pressure distribution varied from one type of motion to another, and the most striking effects and most strongly contested points showed clearly when conditions were restricted to motions of torsional type with the rate of shear maintained constant in space and time, and the forces of inertia kept negligibly small.

The above restrictions were therefore chosen for the present investigation and this choice did not impair seriously the generality of the investigation as it was still possible to study the dependency of the pressure distribution on the rate of shear and other factors, such as the curvature of the flow pattern, the boundary conditions, the properties of the liquid, etc. Moreover, all the types of laminar shearing motions were clearly interconnected, as it was found locally, that is, at every point in a sufficiently small region round the full solid angle, that all the different types approximated to the same homogeneous and rectilinear flow pattern as the surfaces of laminar shear approached tangentially to a series of parallel and equidistant flat planes, and the lines of flow a similar series of straight lines in these planes.

\* The term 'pressure' is used throughout as an abbreviation for 'pressure density' at a point per unit area across a definite plane.

Stress at a point is used as expression for distribution of the pressure around that point across the planes.

The establishment of the experimental technique was based on the use of the Weissenberg Rheogoniometer<sup>1</sup> as an apparatus for the production of laminar shearing motions of the desired torsional type and for the measurement of the associated pressure distribution with the usual equipment of pressure measuring devices, such as spring gauges, capillary tubes, etc. A stationary value for the rate of shear was ensured by containing the liquid in a narrow gap between two platens, the upper one fixed and the lower one rotated at a constant angular velocity. To obtain constancy of the rate of shear in space, gaps of conical shape similar to those introduced by Mooney, were used either in the form of flat plate v. cone or cone/cone (see Fig. 4). In the flat plate v. cone the rate of shear remained constant throughout the gap up to  $4^{\circ}$  (with 2% accuracy). In the cone/cone the constancy was achieved only within  $\frac{1}{2}$  of the surface, and here the distribution of pressure was determined only for points near the surface of the platen. The forces of inertia were minimized by making the width of the gap sufficiently small. It was easy to trace in these gaps the flow pattern of the torsional shearing motion as one found round the axis of the torque lines of flow extending along a series of concentric circles, and the surfaces of laminar shear along a series of coaxial circular cones with a common apex on the axis. Relative to this flow pattern the apparatus was required to determine the distribution of pressure over the various points in the gap, and at each point across the planes of various orientations, using the lines and surfaces of the pattern to specify convenient systems of reference for a quantitative description.

While the measurements were carried out, the greatest care was taken that all experimental conditions inside the liquid and at the boundaries were so adjusted as to cause no disturbances to the desired motion or to the reading of the gauges (within the limits of the required accuracy). This was checked and counterchecked by many experiments so as to make sure of the freedom from disturbances. Great advantages were derived from the restriction to the laminar shearing motions of the torsional type already described, since particularly good use could be made of the high symmetry and curvilinear form of the flow pattern for the complete determination of the pressure distribution and for the avoiding of disturbances, as such a pattern could be fitted smoothly and without distortions into the boundary conditions of the confined space of the gap which contained the liquid in the Rheogoniometer. In spite of these advantages a difficult problem presented itself when attempts were made to determine the pressure distribution which was undisturbed and at the same time experimentally complete, as the very precautions against disturbances made many of the essential points and planes inaccessible to the customary pressure gauge. A solution to the problem was given through the introduction of new devices for generating and measuring pressures across the side boundaries of the gap by Newtonian liquids which had been so standardized that the pressures transmitted to them at a given point and across a given plane could be read off at another point and across another plane conveniently situated for access. These standardized Newtonian liquids were in contact with the liquids under test all along the side boundaries and subjected there to the same rate of shear. The new devices measured, without disturbances, the pressures at points and across planes previously inaccessible, and thus provided new experimental data which, together with these already available were sufficient to determine the pressure distribution completely from the experimental data and first principles only.\*

The new technique was applied to a variety of liquids including Newtonian ones such as water, mercury, oils and Hobson's 'K' stem liquid, and Non-Newtonian ones, such as Rubber in Xylene, Al. Laurate in paraffin and

\* In an earlier investigation<sup>2</sup> K. Weissenberg gave a theoretical solution to the problem by calculating the pressure distribution completely from the experimental data then available using first principles and a supplementary assumption according to which, for a constant rate of shear, the pressure round the full solid angle varied from one point to another only by an additional isotropic pressure. This solution has been found correct by the present investigation so that in future it may be used as an alternative. However, the solution was not experimentally complete as it had to rely on an assumption which at the time was not proved.

special Ragosine oils. The liquids were so chosen that they were easy to experiment with, being stable under large changes of rates of shear.

In addition, some experiments were made with Non-Newtonian liquids which exhibited instability during the laminar shearing motions, showing at stationary rates of shear a breakdown of pressure or a rupture and a tearing off of the liquid from the shearing surfaces. For such unstable liquids it has not yet been possible to obtain reliable information about their pressure distributions, and the present report was therefore confined to the stable liquids enumerated above.

The flowing liquid exercised, at any one point and across any one plane, a pressure whose components normal and tangential to the plane were individually determined in each experiment. The directions of the various planes were orientated at each point relative to the flow pattern by means of a Cartesian system of trirectangular coordinates ( $x_1, x_2, x_3$ ). This system was fixed with its centre in the point considered, and extended its three coordinate planes such that No. 1 was perpendicular to the lines of flow, while Nos. 2 and 3 were parallel to these lines, and respectively parallel and perpendicular to the shearing surface. Proceeding from one point to another, the position of the various points in the pattern was located by means of a system of spherical polar coordinates ( $\rho, \beta, \psi$ ) with the pole fixed in the apex of the conical gap and the pole axis in the axis of the torque. Fig. 3 illustrates the two systems of coordinates in the flow pattern, and shows that at every point No. 1 and  $\psi$  are in the line of flow, No. 2 and  $\beta$  in the normal to the shearing surface, and No. 3 and  $\rho$  in a direction normal to the other two. The investigation covered divers ranges of experimental conditions as it was recognised that the pressure at any point in the liquid, and across any plane there, depended on:

- (a) the position of the point in the gap
- (b) the orientation of the plane in the flow pattern
- (c) the rate of shear present
- (d) the pressure exerted on the side boundary of the gap
- (e) the gravity head at the point
- (f) the forces of inertia\* at the point
- (g) the properties of the liquid

and each of these factors had to be varied over an appropriately wide range in order to assess correctly its contribution to the pressure measurement taken. The experiments which were carried out over a period of 2 years, covered the ground but for economy of space only an extract of them is included in this paper.

A quantitative account of the experimental results obtained is given in Tables 1 - 21 and illustrated by Figs 6-15. From these results a clear picture emerged for the pressure distributions in the various liquids, so much so that it was possible to settle decisively the empirical facts about the most controversial items i.e. about the distributions which the normal components of pressure exhibit over the various points in the gap, and at each point across the planes of various orientations round the full solid angle of directions.

#### Summary:

(1) The normal pressure at any one point and across any one plane was found to be dependent on the experimental conditions according to all the seven factors (a) to (g) enumerated above.

(2) In a given set of experimental conditions, it was found that in a conical gap the normal pressures across all planes of various orientations in the flow pattern increased from the rim ( $\rho = R$ ) to the centre proportional to

\*These forces were kept negligibly small throughout the experiments recorded here, but their importance had to be appreciated in order to avoid disturbances.

Some investigators had made experiments in which the inertia forces were not negligibly small.

the log  $\rho/R$  the proportionality factor being the same for all the different planes, and varying from zero to any value dependent on the conditions of the experiments, and in particular on the flow properties of the liquid and the rate of shear. Photographs recorded typical results obtained for the normal pressures across the No. 2 plane in the flow pattern (shearing plane). The pressure gauges showed clearly the logarithmic increase from the rim to the centre.

(3) For a decision of the controversial items in the pressure distribution, graphs were made in which for each experiment the differences of the normal pressures across the three coordinate planes were plotted against the common logarithmic increase in pressure from the rim to the centre. The theories of the various authors with regard to the results of such plots made significantly different predictions, and these could be tested by comparison with the experimental data of the present investigation as shown in Fig. 6.

(4) The figure showed clearly the incompatibility of the theories of Garner/Nissan and of Reiner/Rivlin with the experimental data, while giving strong support to the theory of Weissenberg which accounted for all the data within the limits of accuracy. There was no indication that the agreement between this theory and the experiments could be improved by the introduction of a correction term, such as suggested by Mooney. In particular, all the experiments showed at every point in the liquid zero values for the difference  $P_{22} - P_{33}$  between the normal pressures across the No. 2 and No. 3 planes, while the normal pressure  $P_{11}$  across the No. 1 plane had the signature of a pull compared with  $P_{22}$  and  $P_{33}$ . The vanishing of the pressure difference  $P_{22} - P_{33}$  at the free boundary of the liquid where both pressures became equal to atmospheric pressure allowing for surface tension effects, can be seen directly in Fig. 1c.

The pressures across the Nos. 2 and 3 planes were always (at any point) found to be equal or greater than that across the No. 1 plane.\*

## 2. Apparatus

The Rheogoniometer<sup>1</sup> had as a framework a precision lathe which was mounted vertically on a heavy base plate \*\* and was driven by a DC motor by means of a system of pulleys, (Fig. 1a).

The liquid under test was subjected to torsional shears in a gap between two boundary platens of which the top one was held statically in a suitably modified tailstock or compound slide rest, whilst the bottom platen was rotated in the headstock. The rotation was derived from a  $\frac{1}{4}$  H.P. DC motor and it was possible to vary the speed of rotation from  $1/10$  r.p.m. to 1,500 r.p.m. by an adjustment of armature voltage and a change of belts on the pulleys. The speed obtained in any one experiment was measured with an accuracy of about 1% by a DC permanent magnet generator coupled to a standard multi range voltmeter. Provisions were made for keeping the rate of shear constant in time and space in the liquid\*\*\* by maintaining a stationary angular velocity on the rotating platen and by making the gap between rotating and static platens of a conical shape with circular symmetry round the axis of torque. Various types of boundary platens were designed accordingly and the ones used which were used here\*\*\*\*formed pairs (see Fig. 4).

---

\*Pressure was counted as positive when it acted on the liquid as a push and negative when it acted as a pull.

\*\* The base allowed an inversion upside down so that a drive could be applied to either the top or bottom platen. In the experiments under discussion the drive was always applied to the bottom platen.

\*\*\* Particularly near the measuring plate.

\*\*\*\* Experiments are under way on other pairs of platens, such as a pair of concentric cylinders (as in a Couette type of apparatus) and a pair of flat plates.

- (a) cone-plate with gap angles of  $1^\circ$ ,  $1\frac{1}{2}^\circ$ ,  $2^\circ$  and  $4^\circ$
- (b) cone-cone with cone angles of  $44^\circ$  and  $46^\circ$ ,  $46^\circ$  and  $45^\circ$
- (c) cone-truncated cone with cone angles of  $44^\circ$  and  $46^\circ$ ,  $46^\circ$  and  $45^\circ$

The platens had a diameter of  $4\frac{1}{2}$ " and were made of aluminium or stainless steel, but it was often advisable to allow observation of the liquid during testing so transparent materials were also used, in particular Perspex and glass (when Perspex was used a careful check had to be maintained on gap size and accuracy as this material distorts easily and is subject to large dimensional changes with temperature). To adjust the setting of the platens, micrometer screws were used which displaced the top platen against the bottom one in three mutually perpendicular directions. The dimensions of the gap were checked by slip gauges and microscopic measurements to an accuracy of .00005".

The liquid in the gap transmitted its pressure to the boundary platens, the components normal to the surface producing an axial thrust and the shear components producing a torque on the platens. The bottom platen was capable of being fitted with a detachable rim  $1\frac{1}{4}$ " high to allow the building up of a gravity head and the application of a corresponding hydrostatic pressure to the liquid in the gap. Several top platens carried devices for pressure measurement in most experiments and a row of capillary gauges was used to indicate the normal pressure components at various points on the top platen whilst the platen as a whole was pivoted so that the torque could be measured by spring adjustment as the position was electrically measured. In some experiments additional measurements were made of the axial thrust and the torque on the top platen, as a whole, by means of capacity gauges and of an appropriately designed elastic suspension\*\* of the platen (see Fig. 5) or by means of a bearing suspension on air.

It was an essential part of the present investigation (see Introduction) that all disturbances be minimised. The set-up of the Rheogoniometer, as described above, was intended to measure the pressure distribution in the desired laminar shearing motion i.e. in an ideal motion defined by an exactly linear interpolation between the motions of the two boundary platens so that each particle of the liquid would move in a circle round the axis of the torque with an angular velocity proportional to its distance from the static platen.

The motions actually produced in the gap and the readings of pressure taken there with the various gauges may have deviated from the ideal ones, and the design of the experimental conditions had to be so calculated as to ensure that all such deviations were eliminated or, at least, kept within the limits of the accuracy required. The exact calculation (see Appendix IV) showed that in a cone/flat plate the rate of shear remained constant throughout the gap up to  $4^\circ$  with an accuracy of 2% while in a cone/cone the constancy was achieved only within  $\frac{1}{2}^\circ$  of the surface and with this apparatus the distribution of pressure was determined only for points near the surface of the first platen<sup>4</sup>. Accordingly the following precautions were taken:-

For the apparatus particular attention was paid to the rigidity of the framework, the alignment between the axis of rotation and the lathe bed, the machining of the platen, the size and rotational symmetry of the gap, etc. Improvements were made until a check with slip gauges and microscopic measurements gave an overall accuracy of about 1%. This accuracy was required to eliminate the Mitchell bearing effect. When both platens were cones, the same high degree of accuracy was required in respect to a parallel sideways displacement, but comparatively little ill effect was experienced when one platen was flat and this sideways displacement kept below .002". Parallelism and correct distance apart of the platens were

\*\* The design of the suspension<sup>3</sup> was originally due to Mr. Richmond of Messrs. Hilger and Watts Ltd. and acknowledgment is gratefully made of this contribution. A modification was made, however, to hold the platen rigidly against up and down movements while the torque was measured and to hold it rigidly against rotation whilst the axial thrust was measured (without such a precaution an intermodulation occurs in the elastic suspension and this falsifies the results particularly when the torque is of considerable strength whilst the axial thrust is comparatively weak).

checked in all cases by hoop gauges at the rim with an accuracy of about .0001". Cross checks were made microscopically, and by observation of the symmetry of the pressure distribution as recorded by the capillary gauges.

For the production of the movement, a special design for the gap had to be developed so as to guard there the ideal motion of the liquid against a variety of dangers. There were the mass forces of gravity and inertia which tended to force the liquid particles out of the ideal circular lines of flow (the gravity vertically downwards and the inertia radially outwards) and which in extreme cases even changed the flow pattern from a laminar to a turbulent one, if the ratio between the mass forces and the shear forces was allowed to exceed a certain critical value corresponding to the Reynolds number. It was possible to estimate the strength of the various forces involved and deduce theoretically that the deviations from the ideal motion would become negligibly small by choosing the orientation of the gap with regard to the gravitation field so that the lines of flow were horizontal, and by making the width of the gap sufficiently narrow so that a comparatively slow speed of rotation of the lower platen sufficed to produce the highest rates of shear required. The efficacy of the set-up was checked and confirmed experimentally by a careful observation of the movement of small air bubbles and of small particles of aluminium dust. No disturbance could be detected in the gaps with apex down while in the gaps with apex up there was a narrow region near the rim of the rotating platen where it was just possible to detect small movements\* radially outwards, but these movements remained negligibly small and well within the limits of accuracy required. There was another danger to be considered with regard to the boundary conditions where the ideal flow pattern might be interfered with by the action of the various devices which were located there to measure the pressure, and to contain it within the allotted space of the gap. Such interference was eliminated for every surface of the liquid by either leaving it entirely free to atmosphere or bounding it by devices designed for a tailor-made fit in space and time to the ideal motion. Such a fit was already provided for the boundaries at the top and bottom of the gap. There, the ideal motion required boundary surfaces of laminar shear which moved the whole rigid units with constant angular velocity, and the boundary platens, being made of solid material provided surfaces which fulfilled these requirements exactly. At the side boundaries of the liquid, however, the use of solid materials had to be excluded because their rigidity would have prevented the particles in the side boundary surface to move there relative to one another, while such a relative movement was required by the ideal motion. When the liquid had a full side boundary it was found that the centrifugal forces were small enough to be neglected up to a rotation speed of the bottom platen of 100 r.p.m., as up to that speed the effect on levels of the line in the capillary gauges was below 1 mm. When standard liquids were used at the side boundary the centrifugal effects were more marked and the speed of the bottom platen had to be limited to 30 r.p.m. if the effects in the capillary gauges were to be kept below 1 mm.

Experiments have been made above the 30 r.p.m. and the centrifugal forces were eliminated by ensuring that the interface was in the gap so that the capillary gauges from the liquid under test could be read off against those of the standard liquid. The liquid under test was therefore so contained in the gap that at the side boundary it was either left entirely free to atmosphere, or bounded by a second liquid which was still inside the gap and thus under the same shearing action as the liquid under test. The second liquid was conveniently chosen of a standard Newtonian type, because this allowed its use not only as a guard for the side boundaries but also as a means to subject these boundaries to normal pressures of measured strength.

For the recording of pressures any possible disturbances from the presence of inertia forces in the liquid were reduced still further by taking all measurements at the static platen where the liquid was at rest. Experimental tests with Newtonian liquids (see Tables 1 - 4) confirmed that such an arrangement worked satisfactorily. Particular care was taken that the location of the pressure gauges did not disturb the motion. Accordingly, no part of the gauges was allowed to protrude into the liquid, and provisions were

\* The rotation platen generated in the neighbouring liquid, inertia forces which in the form of centrifugal forces tended to drive the liquid radially outwards and this drive was here reinforced by the action of the forces of gravity which had a component along that direction in conical gaps with apex up.

made that the gauges located at the boundary surfaces of the liquid conformed to the boundary conditions specified in the preceding paragraph. Such a careful location of the gauges was necessary as otherwise the measurement of pressure would have been taken in a disturbed region and the result would have no significance for the motion under investigation.\* Moreover, the gauges used for the measurement of pressures had to be designed such that the displacements occurring through the actions of measurement were kept negligibly small compared with the gap size. This was achieved by using either mechanical zero methods, as in the cases of capillary gauges and air bearings, or by using electrical gauges of high sensitivity, such as capacity gauges, which recorded all pressures by minute displacements up to  $.00001''$ . When capillary gauges were used there was a danger of false readings being taken because of their slowness of response. In stationary motions there was no objection in principle against using gauges with a slow response but readings had to be taken over a great length of time to make sure that stationary values had been reached when the final readings were recorded. This was done in all the experiments recorded hereafter although in some of them it was necessary to wait for several hours when liquids of high viscosity were used. Effects of surface tension led to some distortions of the surfaces of the liquid at the side boundary of the gap, and in the capillary tubes, but these effects were tested separately and eliminated from the results recorded in the Figures and Tables.

### 3. Materials

The materials under test comprised liquids of the Newtonian and Non-Newtonian types with various colloidal and chemical constitutions. In order to avoid disturbances in the experimental conditions all the liquids had to be so chosen that they possessed the following properties:-

- (a) High degree of homogeneity so that different portions of the liquid had similar properties.
- (b) Good adhesion to the boundary platens with no apparent sineresis.
- (c) High stability under stationary rates of shear so that during each experiment the liquid maintained continuity and the pressure distribution remained constant.
- (d) Good storage stability so as to allow repetition of experiments for check on reproducibility.
- (e) Low vapour pressure at room temperature so as to avoid changes in concentration during an experiment.
- (f) Good mobility so as to:
  - (i) minimise the rises of temperature produced in the liquid by shearing motion, and
  - (ii) keep the recording time in the capillary gauges acceptable.
- (g) Low values of surface tension so that corrections in capillary tubes would be small.

The liquids chosen as representative of the Newtonian type were: water, mercury, Hobson's K stem liquid, light mineral oils etc. These liquids were tested mainly with regard to their normal pressures in order to ensure that they could be used as standards in the experimental technique developed.

The liquids of the Non-Newtonian type included a commercial lubricating

---

\*Some investigators have used capillary tubes which protruded into the gap at various angles in an attempt to measure pressure components in various directions, but such a set-up invalidates the results as the motion of the liquid was disturbed at the point where the measurement was taken.

oil, known under the trade name of "Ragoline Oil" and various colloidal solutions, prepared by Mr. A. J. Taylor, of various percentages of Al.Laurate in T.V.O. and Smoked Sheet Rubber in T.V.O. and paraffin. All these liquids exhibited normal pressures markedly different from those of the standard Newtonian type, the difference being of sufficient strength to allow measurements to an accuracy of about 5%.

The above named solutions have been thoroughly investigated throughout the whole range of conditions as shown by the results given in the tables. In addition, a partial investigation has been carried out on a great variety of other colloidal solutions (including P.V.C. Polyisobutylene, Al.Stearate in Hydrocarbons, Sodium Alginate in water and water emulsions of Rubber Latex and Polyvinyl Acetate. Quantitative data are not included in this paper but it was found that the pressure distributions obeyed the same laws as those of the tabulated liquids throughout the investigated range.

Finally, some experiments were made on liquids of Non-Newtonian types which did not possess the required degree of stability under shear. Some of these liquids such as soap-water solutions (Lux, Persil, etc.) remained continuous under shear but decreased in viscosity under shear. These solutions appeared to obey the same laws as the tabulated ones but the slow recording instruments used were inadequate. These will be investigated further with quick recording instruments. Other liquids such as Aluminium Laurate of high concentration became discontinuous showing a macroscopic tearing off and rolling up of the material between the plates. For the time being it had to be left undecided whether or not the same laws of pressure distribution apply to such unstable liquids.

#### 4. Experimental Technique

Once the motion of the liquid was established and all the precautions taken as indicated above in order to avoid disturbances many points and planes in the flowing liquid were inaccessible to a direct application of the customary pressure gauges. It was with these limitations of access that a technique had to be developed which yielded for the distribution of pressure over the flow pattern a determination which was within the required degree of accuracy, undisturbed and entirely experimental, i.e. derived only from experimental data and from the first principles of continuity, equilibrium of forces and symmetry.\* The principles inter-related the pressures which the flowing liquid exerted at various points and across planes of various orientations, and thus reduced the requirements for empirical measurements of pressure to those taken at accessible points and across accessible planes.

In a quantitative formulation of the experimental technique all parameters of the torsional shearing motion had to be determined and of the associated pressure distribution relative to the flow pattern, whose lines and surfaces provided convenient systems of reference as illustrated in Fig. 3. For the conical gaps here considered it was found that the flow pattern extended its lines of flow along concentric circles round the axis of the torque, and its surfaces of laminar shear along coaxial circular cones with a common apex on the axis, thus tracing a system of spherical polar coordinates ( $\rho, \beta, \psi$ ) with the centre fixed in the apex of the gap and the polar axis in the axis of the torque. (The surfaces of laminar shear were the cones  $\beta = \text{const.}$ , and their intersections with the spheres  $\rho = \text{const.}$ , were the lines of flow along which only  $\psi$  varied). At every point it was found that the coordinates ( $\rho, \beta, \psi$ ) intersected one another at right angles so that it was possible to introduce locally, at each point, a system of coordinates ( $x_1, x_2, x_3$ ) which approximated tangentially to the local flow pattern, and which were so numbered that  $x_1, x_2, x_3$  corresponded respectively to  $\psi, \beta$  and  $\rho$ .

\*It was very important that the considerations of symmetry should take into account not only the motion but all the experimental conditions which could influence the pressure distribution in accordance with the factors (a) to (g) enumerated in the Introduction. (For the normal components of pressure all the factors (a) to (g) were relevant, while for the shearing components only (b) (c) and (g) had to be considered).

The relation between the flow pattern and the various systems of reference was illustrated in Fig. 3 and summarised in the Table below where No. 1 was written for  $x_1$  and  $v$ , No. 2 for  $x_2$  and  $\beta$  and No. 3 for  $x_3$  and  $\rho$ .

	System of Reference:	
	Parallel Axis and Perpendicular Planes	Perpendicular Axis and Parallel Planes
Lines of Flow	No. 1	No. 2 and No. 3
Surfaces of Laminar Shear	No. 1 and No. 3	No. 2

With the help of this Table it was possible to analyse all directional quantities in the flow pattern relative to the directions of the lines of flow and the surfaces of laminar shear since such an analysis was identical with the resolution of these quantities into the components with respect to the axes and planes of the systems of reference.

In order to find out exactly what measurements were required for a complete determination of the pressure distribution in the flow pattern the general laws were applied first to the conditions at any one point round the full solid angle of directions, and then to the changes of these conditions from one point to another throughout the whole of the flow pattern.

At any one point relative to the flow pattern, the strength and direction of the pressures across every plane through the point had to be determined, the relation to the flow pattern being established by means of the Cartesian system of coordinates whose axes and planes were fixed along and at right angles to the lines of flow and surfaces of laminar shear as indicated in Fig. 3. This meant that for a complete determination of the pressure at the point each plane ( $v$ ) of arbitrary orientation in the flow pattern would have to be characterised by its direction cosines ( $v_1 v_2 v_3$  say) and across this plane the strength and directions of the pressure in terms of the three components ( $P(v_1 v_2 v_3)_k$ ) would have to be found taken along the coordinate axes (for  $k = 1, 2, 3$ ). The application of the general laws then revealed that it sufficed to measure the components of pressure across the three coordinate planes of the flow pattern because from these measurements the components of pressure across planes of all orientations in the flow pattern could be calculated, according to the equilibrium condition:-

$$P(v_1 v_2 v_3)_k = P_{1k} v_1 + P_{2k} v_2 + P_{3k} v_3 \quad (\text{for } k = 1, 2, 3) \quad (4a)$$

where the coefficient  $P_{jk}$  denoted the measured value of the ( $k$ ) component of pressure across the ( $j$ ) coordinate plane. It was convenient to enumerate the three times three pressure components  $P_{jk}$  in a quadratic scheme, viz.,

$$P = \begin{vmatrix} P_{11} & P_{12} & P_{13} \\ P_{21} & P_{22} & P_{23} \\ P_{31} & P_{32} & P_{33} \end{vmatrix} \quad (4b)$$

and refer to any one such component as a normal pressure for  $j = k$ , and as a tangential or shearing one for  $j \neq k$ .

In accordance with the scheme (4b) the required number of measurements at the point would have been nine, but this number could be reduced to four because the various  $P_{jk}$  had to satisfy certain conditions of equilibrium and of symmetry. There was an equilibrium between the ( $k$ ) component of pressure across the ( $j$ ) plane, and ( $j$ ) component of pressure across the ( $k$ ) plane, viz.

$$P_{jk} = P_{kj} \quad (\text{for } k \text{ or } j = 1, 2, 3) \quad (4c)$$

There was also a digonal symmetry\* round the No. 3 axis of the flow pattern with respect to all experimental conditions, and this required for the pressure components across the No. 3 plane that

$$P_{31} = P_{32} = 0 \quad (4d)$$

Thus the scheme (4b) simplified to

$$P = \begin{vmatrix} P_{11} & P_{12} & 0 \\ P_{21} & P_{22} & 0 \\ 0 & 0 & P_{33} \end{vmatrix} \quad \text{with } P_{12} = P_{21} \quad (4e)$$

and the only measurements required were those of the three normal components  $P_{11}$ ,  $P_{22}$ ,  $P_{33}$  and of one shearing component  $P_{12}$  or  $P_{21}$  (which ever was more convenient with respect to access). This resolution is shown in Fig. 2.

Proceeding then in the flow pattern from one point to another it was convenient to locate the various points there in terms of the spherical polar system of coordinates  $(\rho, \beta, \psi)$ , as indicated in Fig. 3, and to determine in this system the pressure components as functions of the coordinates of the points, viz.,  $P_{jk}(\rho, \beta, \psi)$ . Progressing from one point to a neighbouring one along the edges of a differential cell, there had to be an equilibrium between the forces of inertia and gravity acting on the mass of the cell, and the traction forces acting as pressures on the surface of that cell. The conditions of equilibrium had to be satisfied along each of the directions  $\rho$ ,  $\beta$  and  $\psi$  where, one found the following conditions. With regard to  $\psi$  it was ensured by the use of torsional shears round a vertical axis that there was a rotational symmetry round that axis for all the relevant experimental conditions so that there was no change of pressure along the  $\psi$  direction, viz.,

$$P_{jk}(\psi) = P_{jk}(0) \quad (\text{for } j \text{ or } k = 1, 2, 3) \quad (4f)$$

With regard to  $\beta$  there was no need to determine the variation of pressure with  $\beta$  for the inclined gaps as the pressure distribution was examined at points near the fixed platen. But for the horizontal gaps it was found from the symmetry conditions\*\* in the plane ( $\beta = \pi/2$ ) of the top platen that the pressure components  $P_{jk}$  remained the same along the  $\beta$  direction (i.e., across the width of the\*\*\* gap) except for a small increase in isotropic pressure from the top to the bottom, viz.,

$$P_{jk}(\beta) = P_{jk}(\pi/2) + \begin{cases} 0 & \text{for } j \neq k \text{ (in horizontal gaps)} \\ G(\rho, \beta, \psi) & \text{for } j = k \end{cases} \quad (4g)$$

where  $G(\rho, \beta, \psi)$  denoted the gravity head at the point  $(\rho, \beta, \psi)$ .

\*A digonal axis along the No. 3 direction corresponds to a rotation by  $180^\circ$  round the No. 3 coordinate axis, thereby transforming the positive directions (+1) (+2) and (+3) respectively into (-1) (-2) and (-3). For the pressure components  $P_{jk}$  it was therefore found  $P_{3k} = \begin{cases} +P_{3k} & \text{for } k = 3 \text{ and hence} \\ -P_{3k} & \text{for } k \neq 3 \end{cases}$  and hence  $P_{31} = P_{32} = 0$ .

\*\*There was a digonal axis of symmetry along every diameter in the plane ( $\beta = \pi/2$ ) of the top platen when the gravitational field was neglected. This symmetry required that  $P_{jk}(\pi/2 + \delta\beta) = P_{jk}(\pi/2 - \delta\beta)$  so that there was no change in pressure along the direction near the plane ( $\beta = \pi/2$ ). Taking then account of the gravitational field (4g) was found.

\*\*\*Provided the gap was small.

Finally, it was found for the  $\rho$  direction from (4e) to (4g) and the conditions of equilibrium (4f)\*

$$\frac{\partial P_{33}(\rho)}{\partial \ln \rho} + 2P_{33}(\rho) - P_{22}(\rho) - P_{11}(\rho) = \begin{cases} 0 & \text{for horizontal gaps} \\ -G(\rho, \beta, \nu) & \text{for inclined gaps} \end{cases} \quad (4h)$$

The reduction in the number of measurements required could now be clearly seen. It sufficed to measure the pressure components  $P_{jk}$  only along one series of points lying in the boundary surface of the top platen along a line in the  $\rho$  direction (i.e. along a line  $\beta = \text{const.}$ , and  $\nu = \text{const.}$ ) as it was possible to calculate from these measurements the values of  $P_{jk}$  at all points with arbitrary coordinates  $(\rho, \beta, \nu)$ , according to (4f) and (4g). Moreover, it sufficed to measure only two of the three normal components and  $\partial P_{33} / \partial \ln \rho$  and to calculate the third from the equilibrium condition (4h). A measurement of the component  $P_{11}$  across the No. 1 plane was impracticable because this plane was inaccessibly hidden inside the liquid and could not be exposed without creating a serious disturbance of the flow pattern. However, this component was determined from (4h) measurement of  $P_{22}$  and  $P_{33}$  and  $\partial P_{33} / \partial \ln \rho$  as described below. It was possible to measure the components across the No. 2 plane with the customary pressure gauges because this plane extended along the boundary surface between the liquid and the top platen and was thus easily accessible. The value of  $P_{22}$  was read from the capillary gauge at the point considered, and the value of  $P_{21}$  was found from the torque on the top platen. Finally, the measurement of  $P_{33}$  across the No. 3 plane was made possible by using a special set up. In this the No. 3 plane became a side boundary of the liquid under test, and remained undisturbed while being exposed either as a free boundary to atmosphere, or as an interface to a liquid of the standard Newtonian type, i.e. a liquid which conformed at every point to the condition that it exhibited equal normal pressures across all the coordinate planes, and that the common value of that pressure was for all rates of shear ( $\dot{c}$ ) equal to the gravity head ( $G$ ) at the point plus atmospheric pressure ( $\pi$ ) viz.,

$$\bar{P}_{kk}(\dot{c}) = \bar{P}_{kk}(0) = G + \pi \quad (\text{for } k = 1, 2, 3)$$

(The bar in the symbol  $\bar{P}$  denoted that the pressure referred to the standard liquid and not to the liquid under test). In the case of a free boundary  $P_{33}$  equalled to the atmospheric pressure ( $\pi$ ) while in the case of an interface the amount of pressure  $P_{33}$  transmitted to the standard liquid as  $\bar{P}_{33}$  could be read off as  $P_{22}$  on the capillary gauge adjacent to the interface as  $\bar{P}_{33} = P_{22}$ . Altogether all the four non-vanishing pressure components had been determined at the point, and these in turn could be used to calculate the whole pressure distribution throughout the gap (according to (4a - 4h)) (see Appendix 1).

## 5. Experimental Testing of the Liquids

### 5.1 Liquids of the Standard (Newtonian) type

For the experimental technique discussed in the previous section, Newtonian liquids of a standard type were necessary, which in a laminar shearing motion would conform at every point and at all rates of shear ( $\dot{c}$ ) to the standardization condition:-

$$\bar{P}_{kk}(\dot{c}) = \bar{P}_{kk}(0) = G + \pi \quad (\text{for } k = 1, 2, 3) \quad (5a)$$

Liquids of the standard type could not exhibit any pressure gradient from the rim to the centre because the vanishing of this gradient followed from (5a) and the condition of equilibrium (4h) for all rates of shear, became

$$\frac{\partial \bar{P}_{33}(\rho)}{\partial \ln \rho} = \frac{\partial \bar{P}_{22}(\rho)}{\partial \ln \rho} = \frac{\partial \bar{P}_{11}(\rho)}{\partial \ln \rho} = 0. \quad (5b)$$

\*The conditions of equilibrium were formulated for all three directions (see Appendix III) but only in the  $\rho$  direction did they provide additional information, as the conditions with regard to  $\beta$  and  $\nu$  were already contained in (4f) and (4g).

As the Newtonian character of a liquid had usually been established only with regard to the shear components ( $\bar{P}_{12}$  and  $\bar{P}_{21}$ ) it was necessary to check experimentally whether such liquids conformed to the standardization condition (5a) regarding the normal components of pressure. Liquids of various densities were chosen (see section Materials) and checked with respect to (5a) as follows:-

The liquid was placed in the gap of the truncated cone apparatus (Fig. 4c) and examined first at rest, and then under various shears. The shears were produced by rotating the bottom cone at a constant angular velocity against the statically held top cone which was truncated and built as a measuring head holding the capillary gauges. The truncation level divided the liquid in the gap into two parts which suffered widely different rates of shear. While the upper part of the liquid, contained in the narrow section above the truncation level suffered a stationary rate of shear which varied from one experiment to another between 0 and 50  $\text{sec.}^{-1}$ , it was found that the lower part of the liquid, contained in the wide section below the truncation level, remained practically static throughout all the experiments. Fig. 4c illustrates how the pressure measurements were carried out for a point B, immediately above the truncation level (using Newtonian liquid only, both liquids are shown in figure). The flow pattern at this point was that described in the preceding section with coordinate planes No. 1 extending in the paper plane, No. 2 tangentially to the cone surface containing the line AB, and No. 3 perpendicular to the other two so that this plane separated the sheared part of the liquid from the practically unsheared part.

The liquid at rest (i.e. for zero rate of shear) was isotropic and exhibited therefore at every point across planes of all orientations a normal pressure equal to the gravity head (G) at the point plus atmospheric pressure ( $\pi$ ), and the value of this pressure could be read off in the capillary gauge at the point (when atmospheric pressure was taken as the zero level). Here it was found that the condition (5a) was trivially fulfilled according to:

$$\bar{P}_{kk}(0) = G + \pi \quad (\text{for } k = 1, 2, 3) \quad (5c)$$

Proceeding then to experiments with various rates of shear the pressure component  $\bar{P}_{22}$  for the point B was observed in the capillary gauge at B (see Fig. 4c). For stationary rates of shear varying between 0 and 50  $\text{secs}^{-1}$  no change in pressure was observed, viz.,

$$\bar{P}_{22}(\dot{c}) = \bar{P}_{22}(0) \quad (\text{for point B}) \quad (5d)$$

For the observation of the pressure component  $\bar{P}_{33}$  at the point B it was noted that this component was transmitted across the No. 3 plane\* to the static part of the liquid where it was recorded in every one of the capillary gauges below the truncation level according to (5c) (see Fig. 4c). The observation of these capillary gauges again showed no changes in pressure for the various rates of shear, and hence

$$\bar{P}_{33}(\dot{c}) = \bar{P}_{33}(0) \quad (\text{for point B}) \quad (5e)$$

Finally, the pressure component  $\bar{P}_{11}$  was calculated at the point B from the equilibrium condition (4a), and again no changes for the various rates of shear were found so that

$$\bar{P}_{11}(\dot{c}) = \bar{P}_{11}(0) \quad (\text{for point B}) \quad (5f)$$

This completed the check since equations (5c) (5d) (5e) and (5f) together confirmed the compliance of the liquid under test to the standardization

\* It had not been possible to ascertain the exact orientation of the plane which separated in the gap the sheared part of the liquid from the unsheared one, so that this plane may have been at an angle to the No. 3 plane. However, it could be shown that such an angular deviation did not in any way detract from the validity of the check. (See Appendix No. II).

condition. The values actually obtained for the various liquids here considered are given in Tables 1 - 4. Several counter-checks were made in order to make quite sure that the selected liquids could be used as standard ones. Confirmation was obtained in experiments made in the cone-flat plate apparatus with horizontal gaps when additional pressure was put across the side boundary of the gap.

In all experiments was observed a zero pressure gradient from the rim to the centre in accordance with (5b).

Tables 5 - 8 give some of the results obtained in the counter-checks.

By the above tests it was established that the liquids listed in the Tables (1 - 4) could be used as standard ones.

## 5.2 Liquids of Non-Standard Types

Various liquids have been found which belonged to a general (non-standard) type as they exhibited in the conical gaps marked pressure gradients in the radial direction from the rim to the centre deviating from the standardization condition, (5a). The testing of all such liquids relied on the use of liquids of the standard Newtonian type, now made available in accordance with the checks made in the preceding paragraph.

For the liquids of the general Non-standard type a number of systematic series of experiments was made in order to assess the influence on the pressure distribution of the experimental conditions, with regard to all the factors (a) to (g) enumerated in the Introduction. Most experiments were carried out in the horizontal cone-flat plate gap where the distribution could be determined at all points because in the horizontal cone-flat plate gap all the points suffered the same rate of shear. However, some preliminary experiments were made in the inclined double cone gap which was particularly well suited for a simultaneous measurement of all three normal components  $P_{11}$ ,  $P_{22}$  and  $P_{33}$ , although these pressure components could be measured only for the points which had the same rate of shear and extended along the surface of the top cone and from it to a depth of  $\frac{1}{2}$ .

For ease of discussion the interface between the general and the standard liquid was always regarded as a surface No. 3. The justification for this was derived from the exact treatment, given in Appendix II where the uncertainty of the exact orientation of the interface was taken into account.

In the preliminary experiments the general liquid was sandwiched between two layers of standard liquids in the inclined double cone gap (with or without the top cone truncated).\*

With this set-up it was possible to read off at each interface the corresponding values of  $P_{22}$  and  $P_{33}$  of the general liquids on the capillary gauges on either side of the interface, the gauge on the side of the general liquid recording the  $P_{22}$  acting across the conical surface (No. 2) and the gauge on the side of the standard liquid recording the  $P_{33}$  acting across the surface of the interface No. 3. The extrapolation of the gauge readings to the values at the interface was facilitated by the fact that in every experiment the gauges were all on the same horizontal level over the two layers of standard liquid, and showed over the sandwiched layer occupied by the general liquid the typical logarithmic increase in the radial direction from the outer interface to

\*In this gap it was irrelevant in principle, whether or not the top cone was truncated. However, for practical reasons the truncated top cone was used in preference to the untruncated one, because the setting-up with a sufficient degree of accuracy took less time for the truncated top cone.

\*\*In comparing the readings of the capillary gauges of the liquids of the two kinds, due account has to be taken of the difference in their densities and surface tension.

the inner ones\* (see Fig. 4c). When a series of experiments was carried out at the same rate of shear at various levels of the interface,  $P_{22}$  and  $P_{33}$  were obtained as functions of  $\rho$ , and  $P_{11}$  was calculated as function of  $\rho$ , from the equilibrium condition (4h). In subsequent series of experiments of this kind the experimental conditions were varied systematically with regard to the various factors (a) to (g) and found for every liquid examined, at every rate of shear, at every point of the cone, and for all pressures exerted across the side boundary,

$$P_{33} - P_{22} = 0 \quad (5g)$$

$$P_{22} - P_{11} = P_{33} - P_{11} = \frac{\partial P_{33}}{\partial \ln \rho} = \frac{\partial P_{22}}{\partial \ln \rho} = \frac{\partial P_{11}}{\partial \ln \rho} \quad (5h)$$

Tables 9 - 21 give typical examples of the results obtained.

Proceeding then to the horizontal cone/flat plate gap analogous series of experiments were carried out and measured there in addition to the three normal pressure components  $P_{11}$   $P_{22}$   $P_{33}$ , also the shearing component  $P_{21}$  of the general liquid. The experimental procedure had to be changed to a certain amount, as the flow conditions became unstable when the general liquid was sandwiched between two layers of standard liquids. However, stable conditions were obtained by putting the standard liquid on the outside only. The rim attachment to the bottom cone then allowed a build-up of the gravity head for the standard liquid to any required pressure, the liquids of high specific gravity (mercury and Hobson's K stem liquid) being used to obtain a wide range of pressures within the available height of the rim attachment. For every general liquid under test, and every rate of shear, a series of experiments had to be carried out first with a free side boundary of the general liquid to atmosphere, and then with a boundary to the standard liquid with the interface formed at several distances from the centre. In each case the gravity head of the standard liquid had to be adjusted to a height till all the capillary gauges over the general liquid recorded the same values as in the experiment with a free boundary. In this way it was again possible to measure on either side of the interface the values of  $P_{22}$  and  $P_{33}$  as functions of  $\rho$ , and calculate the values of  $P_{11}$  as function of  $\rho$ , from the equilibrium conditions. It was noted for the capillary gauges that those which recorded the pressures over the annulus of the standard liquid were all on the same horizontal level, while those which recorded the pressures over the inner portion occupied by the general liquid showed the typical logarithmic increase in the radial direction from the interface to the centre. (See Figs. 1b and 1c). The relations (5g) and (5h) were also fully confirmed and established by the experiments. Finally, the effect of a change in the rate of shear on the shearing component of pressure  $P_{21}$  and on the differences in the normal pressures was measured. A selection of typical results is given in the Figs. 13, 14 and 15 and Tables 9 - 21. A complete picture of the pressure distribution in the horizontal gaps could then be calculated from the measured data in accordance with equations (4e) to (4h).

## 6. Theoretical Discussion of Experimental Evidence

In the course of an experimental investigation (1943 - 45) K. Weissenberg tested the predictions of his earlier theories<sup>6</sup> (1934), and demonstrated for a variety of visco-elastic liquids, including saponified oils, solutions of rubber, starch, cellulose acetate, etc., that normal components of pressure could be produced in great strength when these liquids were subjected to certain laminar shearing motions. Various theories were then proposed to account for the appearance of such normal components of pressure, and these theories were considered in the light of the available experimental evidence.

For ease of comparison the theories were formulated for shearing motions of torsional type in a horizontal gap of conical shape in which the rate of shear was maintained constant in space and time, and all data were

\*It was convenient to read off all pressure gauges from the same horizontal level so as to compensate for the gravity head which increased steadily from the outer interface to the inner one.

referred to the flow pattern of the motion by way of the systems of Cartesian and spherical polar coordinates illustrated in Fig. 3.

There was a common basis available for a comparison of the various theories as certain features of the pressure distribution could be deduced by applying only first principles and considerations of symmetry as shown previously. In particular it was found that for any point in the laminar shearing motion the pressure distribution round the full solid angle was such that the components of pressure across the coordinate planes of the flow pattern were given by

$$P = \begin{vmatrix} P_{11} & P_{12} & 0 \\ P_{21} & P_{22} & 0 \\ 0 & 0 & P_{33} \end{vmatrix} \text{ with } P_{12} = P_{21} \quad (6a)$$

as shown in Fig. 2 where every component was to be considered as a function of the coordinates of the point  $(\rho, \beta, \psi)$ . Proceeding then from one point to another it was found for the experimental conditions specified above that the various pressure components were functions of  $\rho$  only, and that these functions had to satisfy the equilibrium condition

$$\frac{\partial P_{33}}{\partial \ln \rho} + 2P_{33} - P_{22} - P_{11} = 0 \quad (6b)$$

According to such general theory, represented by (6a) and (6b) the values of the three components of normal pressure ( $P_{11}$ ,  $P_{22}$ ,  $P_{33}$ ) could all have been different from one another at the same point, and it was here that the special theories of the various authors made different assumptions.

Garner, Nissan and Wood. These authors considered liquids of a visco-elastic type, capable of storing free energy in amounts steadily increasing with the rate of shear<sup>5</sup>. A theory was then developed on the assumption that at every point the three normal components of pressure were equal to one another, and that a pressure difference would develop between two adjacent portions of the liquid if, and only if, the two portions moved at different rates of shear and thus contained different amounts of free energy per unit volume.

For the experimental conditions here considered the rate of shear did not vary in the radial direction so that the theory required zero values for  $\frac{\partial P_{33}}{\partial \ln \rho}$  and for the differences between the three components of normal pressure, viz., (G.N.W.1)  $(P_{11} - P_{22}) = (P_{22} - P_{33}) = (P_{33} - P_{11}) = \frac{\partial P_{33}}{\partial \ln \rho} = 0$

Reiner - Rivlin. These authors considered liquids of a type so defined that at every point the main axes of stress should be parallel to those of the strain velocity. Reiner introduced these liquids merely as an ideal type<sup>7</sup>, which may or may not exist, and derived for it the most general (non-linear) relationship between stress and strain velocity. Rivlin then claimed that the liquids which Weissenberg had used in his experiments conformed to this ideal type and that the non-linear terms in the relationship between stress and strain velocity accounted for the observed normal pressures.

For the experimental conditions here considered the theory of the authors required that at every point and at all rates of shear

$$P_{11} = P_{22} \quad (\text{R and R1})$$

so it was found for the differences in the normal components of pressure

$$P_{11} - P_{22} = 0 \text{ and} \\ (P_{11} - P_{33}) = (P_{11} - P_{33}) = \frac{1}{2} \frac{\partial P_{33}}{\partial \ln \rho} \quad (\text{R and R2})$$

in accordance with the equilibrium equation.

Weissenberg. This author considered liquids of a general visco-elastic type, and first developed the theory in its general form<sup>6</sup>. He then introduced an assumption according to which planes of various orientations passing through one point exhibited the same normal pressures per unit area if, in due course of the motion, these planes had suffered per unit area the same normal displacement relative to their parallel neighbouring planes.

For the experimental conditions here considered this theory required that at every point, and for all rates of shear

$$P_{22} = P_{33} \quad (W1)$$

so that one found for the three differences of normal pressures

$$P_{22} - P_{33} = 0 \quad \text{and} \\ (P_{11} - P_{22}) = (P_{11} - P_{33}) = \frac{\partial P_{33}}{\partial \ln \rho} \quad (W2)$$

in accordance with the equilibrium equation. The author applied his assumption not only to the movement as a whole, but also to that part of the movement which corresponds to the recoverable strain, i.e. which could be elastically recovered when all the forces were suddenly released. In this way he linked the effects of normal pressures to the elastic properties of the liquid in shear, but a discussion of such a link had to be postponed as the experiments relating to it have not yet been completed. It is hoped to make experiments on recoverable strain to further check this theory.

Mooney. Recently Mooney<sup>9</sup> suggested a more general form of Weissenberg's theory by introducing an elasticity law which contained two material characteristics, one the shear modulus (G) and another modulus (H) which in addition showed up in normal pressures. Mooney's theory coincides with Weissenberg's  $G - H = 0$  while for  $G - H \neq 0$  the difference between  $P_{22}$  and  $P_{33}$  is  
(M.1)  $P_{22} - P_{33} = (G - H)3C$  when  $C = \text{Const.}$  for each experiment.

Mooney's theory was found to be compatible with the experimental results only when it coincided with Weissenberg's theory, i.e. when  $G - H = 0$ .

In a summary, the theories of the various authors could conveniently be compared with one another, and with the experimental data given in this paper, by plotting each of the differences of the three normal pressures, i.e.,

$$(P_{11} - P_{22}), (P_{22} - P_{33}), (P_{33} - P_{11}) \quad \text{against} \quad \frac{\partial P_{33}}{\partial \ln \rho}$$

As some of these quantities were essentially positive, while the others were essentially negative it was convenient to plot each quantity with its appropriate sign. The plot shown in Fig. 6 gave a comprehensive picture of all the results obtained. It was seen from this plot that the experimental evidence was incompatible with the theories of Garner, Nissan and Wood and of Reiner and Rivlin, while strongly supporting the theory of Weissenberg. Further support was given by the results of the partial investigation of large varieties of liquids which whilst not tabulated had been shown to conform to equations W.1 and W.2 at the rim where direct observations of  $P_{22}$  and  $P_{33}$  could be made.

One might have expected to find the data for the real liquids somewhere between the various theoretical lines which corresponded to the idealised types of liquids considered by the various authors. However, this was not the case as it was found from all the experimental data recorded in Fig. 1 that the results approximated to the ideal type of Weissenberg theory within the limits of experiment and error while they were incompatible with the ideal types of the theories of Garner and Nissan, Reiner and Rivlin except in the trivial case near the zero point where the ideal types of all the theories became indistinguishable. This difference between theory and experiment was well outside the experimental error above values of  $\partial P_{33} / \partial \ln \rho > 1 \times 10^3$  dynes/cm<sup>2</sup>.

### Acknowledgements

The author is indebted to Dr. K. Weissenberg, Dr. M. Reiner, and Dr. A. H. Nissan for discussion on their theories, and to S. M. Freeman, C. N. Richmond and D. Wyld for discussion on the Rheogoniometer.

Thanks are also due to E. D. Rowell and E. S. Lawes who have developed special apparatus for accurate photography of the pressure gauges.

### List of References

- (1) Freeman S. M. , Rheogoniometer, Report of the General Conference of British Rheologists' Club, Oct. 1946 (Nelson & Sons).
- (2) Weissenberg K., Proc. Inst. Rheol. Congress Holland, 1948.
- (3) Richmond C. N., Rheogoniometer, Report of Investigation of Grid Measuring Unit. (Private Communication).
- (4) Mooney M. and Ewart R. H., Physics 5. 350 - 355 Nov. 1934.
- (5) Garner F. H., Nissan A. H., Wood G. F., Phil. Trans. A. 243, 858 37 - 66, 1950.
- (6) Weissenberg K., Abh. Pr. Akad. Wiss. No. 2 1931 and Ach. Sci. Phys. et Nat. J. 17.1.1934.
- (7) Reiner M. Am. J. Math.
- (8) Rivlin R. S. and Greensmith H. W. Nature, 168, 4276, 664 - 5, 1951.
- (9) Mooney M., J. Coll. Sci. 6, No. 2, 96 - 107, 1951.

Tables 1 and 5 are for a Newtonian Type Light Oil)

Tables 2 and 6 are for Water

Tables 3 and 7 are for Hobson's K stem Liquid

Tables 4 and 8 are for Mercury

at different  
rates of shear

The results for Tables 1-4 are for a Truncated Cone/Cone  $44^{\circ}/46^{\circ}$ .

The results for Tables 5-8 are for a  $1^{\circ}$  Cone/Flat Plate

The results for Tables 9-13 are for 3" Al. Laurate/TVO at different rates of shear.

The results for Tables 14-17 are for 5% Rubber/Smoked Sheet/Xylene.

The results for Tables 18-21 are for R.O.C. oil sample 6726.

Apparatus:  $1^{\circ}$  Cone/Flat Plate (at different rates of shear)

The Tables are corrected for surface tension and the logarithmic mean of the tube is taken as the pressure point.

A negative sign denotes a pull.

TABLE NO. 1

Material: Newtonian type light oil

Density = 0.873 gm/cc.

Apparatus Truncated Cone/Cone  $44^{\circ}/46^{\circ}$ 

No. of Tube	P <sub>22</sub>							P <sub>33</sub>	Rate of Shear sec <sup>-1</sup>
	1	3	5	7	9	11	13	At Rim	
Height of liquid in cms. allowing for Surface Tension	0	0	0	0	0	0	0	0	0.5
	0	0	0	0	0	0	0	0	5.0
	0	0	0	.05	0	0	0	0	50.0
	1.8	1.8	1.8	1.8	1.75	1.8	1.8	1.8	0.5
	1.8	1.8	1.8	1.8	1.8	1.8	1.8	1.8	5.0
	1.8	1.8	1.8	1.8	1.75	1.75	1.8	1.8	50.0

TABLE NO. 2

Material: Water

Apparatus: Truncated Cone/Cone  $44^{\circ}/46^{\circ}$ 

No. of Tube	P <sub>22</sub>							P <sub>33</sub>	Rate of Shear sec <sup>-1</sup>
	1	3	5	7	9	11	13	At Rim	
Height of liquid in cms. allowing for Surface Tension	0	0	0	0	0	0	0	0	0.5
	0	0	0	0	0	0	0	0	5.0
	0	0	0	0	0	0	0	0	50.0
	1.9	1.9	1.9	1.9	1.9	1.9	1.9	1.9	0.5
	1.9	1.9	1.9	1.9	1.9	1.9	1.9	1.9	5.0
	1.9	1.9	1.9	1.85	1.85	1.9	1.9	1.9	50.0

TABLE NO. 3

Material: Hobson's K Stem liquid

Density: 2.96 gm./cc.

No. of Tube	P <sub>22</sub>							P <sub>33</sub>	Rate of Shear sec <sup>-1</sup>
	1	3	5	7	9	11	13	At Rim	
Height of liquid in cms. allowing for Surface Tension	0	0	0	0	0	0	0	0	0.5
	0	0	0	0	0	0	0	0	5.0
	0	0	0	0	0	0	0	0	50.0
	1.7	1.7	1.7	1.7	1.7	1.7	1.7	1.7	0.5
	1.7	1.7	1.7	1.7	1.7	1.7	1.7	1.7	5.0
	1.7	1.7	1.7	1.65	1.65	1.7	1.7	1.7	50.0

TABLE NO. 4

Material: Mercury

Apparatus: Truncated Cone/Cone  $44^{\circ}/46^{\circ}$ 

No. of Tube	P <sub>22</sub>							P <sub>33</sub> At Rim	Rate of Shear sec <sup>-1</sup>
	1	3	5	7	9	11	13		
Height of liquid in cms. allowing for Surface Tension	0	0	0	0	0	0	0	0	0.5
	0	0	0	0	0	0	0	0	5.0
	0	0	0	0	0	0	0	0	50.0
	1.8	1.8	1.8	1.8	1.8	1.8	1.8	1.8	0.5
	1.8	1.8	1.8	1.8	1.8	1.8	1.8	1.8	5.0
	1.8	1.8	1.8	1.75	1.75	1.8	1.8	1.8	50.0

TABLE NO. 5

Material: Newtonian type light oil

Density = 0.873 gm/cc.

Apparatus: 1° Cone/Flat Plate

No. of Tube	P <sub>22</sub>								P <sub>33</sub> At Rim	Rate of Shear sec <sup>-1</sup>
	1	3	5	7	9	11	13	15		
Height of liquid in cms. allowing for Surface Tension	0	0	0	0	0	0	0	0	0	0.5
	0	0	0	.1	0	0	0	0	0	5.0
	0	0	0	0	0	0	0	0	0	50.0
	1.2	1.2	1.3	1.2	1.2	1.2	1.2	1.2	1.2	0.5
	1.15	1.2	1.2	1.15	1.15	1.2	1.2	1.2	1.2	5.0
	1.15	1.15	1.15	1.15	1.15	1.15	1.15	1.2	1.2	50.0

TABLE NO. 6

Material: Water

Apparatus: 1° Cone/Flat Plate

No. of Tube	P <sub>22</sub>								P <sub>33</sub> At Rim	Rate of Shear sec <sup>-1</sup>
	1	3	5	7	9	11	13	15		
Height of liquid in cms. allowing for Surface Tension	0	0	0	0	0	0	0	0	0	0.5
	0	0	0	0	.05	0	0	0	0	5.0
	0	0	0	0	0	0	0	0	0	50.0
	1.5	1.5	1.5	1.5	1.5	1.5	1.5	1.5	1.5	0.5
	1.5	1.5	1.55	1.5	1.5	1.5	1.5	1.5	1.5	5.0
	1.5	1.5	1.5	1.5	1.5	1.5	1.5	1.55	1.5	50.0

TABLE NO. 7

Material: Hobson's K Stem Liquid

Density = 2.96 gm/cc

Apparatus: 1° Cone/Flat plate

No. of Tube	P <sub>22</sub>								P <sub>33</sub> At rim	Rate of Shear sec <sup>-1</sup>
	1	3	5	7	9	11	13	15		
Height of liquid in cms. allowing for Surface Tension	0	0	0	0	0	0	0	0	0	0.5
	0	0	0	0	0	0.1	0	0	0	5.0
	.05	0	0	0	0	0	.05	.05	.05	50.0
	1.6	1.6	1.6	1.6	1.6	1.65	1.6	1.6	1.6	0.5
	1.6	1.6	1.6	1.6	1.6	1.6	1.6	1.6	1.6	5.0
	1.7	1.7	1.7	1.65	1.65	1.7	1.7	1.7	1.7	50.0

TABLE No. 8

Material: Mercury

Apparatus: 1° Cone/Flat Plate

No. of Tube	P <sub>22</sub>								P <sub>33</sub> At Rim	Rate of Shear sec <sup>-1</sup>
	1	3	5	7	9	11	13	15		
Height of liquid in cms. allowing for Surface Tension	0	0	0	0	0	0	0	0	0	0.5
	0	0	0	0	0	0	0	0	0	5.0
	.05	.05	0	0	0	0	.05	.05	.05	50.0
	1.3	1.3	1.3	1.3	1.3	1.3	1.3	1.3	1.3	0.5
	1.3	1.3	1.3	1.3	1.3	1.3	1.3	1.3	1.3	5.0
	1.25	1.2	1.25	1.2	1.2	1.2	1.25	1.25	1.25	50.0

TABLE NO. 9

Material: 3% Al. Laurate/T.V.O.

Rate of Shear:  $50 \text{ sec}^{-1}$ 

Density: 0.83 gm/cc.

Gauge No.	P <sub>11</sub>	P <sub>22</sub>	P <sub>33</sub>	$\frac{\partial P_{33}}{\partial \ln r}$	$\frac{P_{11} - P_{22}}{\partial P_{33}/\partial \ln r}$	$\frac{P_{22} - P_{33}}{\partial P_{33}/\partial \ln r}$	$\frac{P_{11} - P_{33}}{\partial P_{33}/\partial \ln r}$
	Dynes/sq. cm.						
1	4400	0	0	Average Value	Average Value	Average Value	Average Value
2	3700	680	700				
3	2900	1500	1500				
4	2100	2500	2400	- 4420	1.00	.003	1.0
5	700	3700	3700				
6	900	5500	5400				
7	3900	8100	8200	—	—	—	—
8	—	—	—				
9	3600	8400	8200				
10	700	5700	5400	1.07	.034	1.03	1.03
11	900	3900	3700				
12	2200	2550	2400				
13	3100	1700	1500	—	—	—	—
14	3700	700	700				
15	4400	0	0				

TABLE NO. 10

Material: 3% Al. Laurate/T.V.O.

Rate of Shear:  $38 \text{ sec}^{-1}$ 

Density: 0.83 gm/cc.

Gauge No.	P <sub>11</sub>	P <sub>22</sub>	P <sub>33</sub>	$\frac{\partial P_{33}}{\partial \ln r}$	$\frac{P_{11} - P_{22}}{\partial P_{33}/\partial \ln r}$	$\frac{P_{22} - P_{33}}{\partial P_{33}/\partial \ln r}$	$\frac{P_{11} - P_{33}}{\partial P_{33}/\partial \ln r}$
	Dynes/sq. cm.						
1	-3500	0	0	Average Value	Average Value	Average Value	Average Value
2	-3000	500	500				
3	-2300	1000	1100				
4	-1600	1750	1800	- 3460	.99	- .004	1.00
5	- 400	2750	2900				
6	400	4500	4200				
7	3600	6900	7000	—	—	—	—
8	—	—	—				
9	3500	7050	7000				
10	700	4250	4200	1.04	.014	1.03	1.03
11	-700	3000	2900				
12	-1800	1900	1800				
13	-2500	1200	1100	—	—	—	—
14	-3000	500	500				
15	-3500	0	0				

TABLE NO. 11

Material: 3% Al. Laurate/T.V.O.

Rate of Shear: 34 sec.<sup>-1</sup>

Density: 0.83 gm/cc

Gauge No.	P <sub>11</sub>	P <sub>22</sub>	P <sub>33</sub>	$\frac{\partial P_{33}}{\partial \ln r}$	$\frac{P_{11} - P_{22}}{\partial P_{33} / \partial \ln r}$	$\frac{P_{22} - P_{33}}{\partial P_{33} / \partial \ln r}$	$\frac{P_{11} - P_{33}}{\partial P_{33} / \partial \ln r}$
	Dynes/sq. cm.						
1	- 2400	0	0	Average Value	Average Value	Average Value	Average Value
2	- 2100	300	300				
3	- 1620	650	700	- 2370	1.01	.003	1.01
4	- 1300	1300	1200				
5	- 600	1800	1800	—	—	—	—
6	250	2800	2700				
7	2300	4500	4600	—	—	—	—
8	—	—	—				
9	2100	4750	4600	—	—	—	—
10	50	3000	2700				
11	- 800	2000	1800	—	1.01	.054	1.05
12	- 1320	1350	1200				
13	- 1800	800	700	—	—	—	—
14	- 2100	300	300				
15	- 2400	0	0	—	—	—	—

TABLE NO. 12

Material: 3% Al. Laurate/T.V.O.

Rate of Shear: 26 sec.<sup>-1</sup>

Density: 0.83 gm/cc

Gauge No.	P <sub>11</sub>	P <sub>22</sub>	P <sub>33</sub>	$\frac{\partial P_{33}}{\partial \ln r}$	$\frac{P_{11} - P_{22}}{\partial P_{33} / \partial \ln r}$	$\frac{P_{22} - P_{33}}{\partial P_{33} / \partial \ln r}$	$\frac{P_{11} - P_{33}}{\partial P_{33} / \partial \ln r}$
	Dynes/sq. cm.						
1	- 1240	0	0	Average Value	Average Value	Average Value	Average Value
2	- 1000	150	200				
3	- 800	350	400	- 1240	1.00	- .0	1.00
4	- 550	700	700				
5	- 300	1050	1000	—	—	—	—
6	300	1650	1600				
7	1200	2400	2400	—	—	—	—
8	—	—	—				
9	1000	2600	2400	—	—	—	—
10	350	1600	1600				
11	- 200	950	1000	—	1.04	.012	1.01
12	- 550	700	700				
13	- 850	400	400	—	—	—	—
14	- 1000	150	200				
15	- 1240	0	0	—	—	—	—

TABLE NO. 13

Material: 3% Al. Laurate/T.V.O.

Rate of Shear: 15 sec.<sup>-1</sup>

Density: .83 gm/cc

Gauge No.	P <sub>11</sub>	P <sub>22</sub>	P <sub>33</sub>	$\frac{\partial P_{33}}{\partial \ln r}$	$\frac{P_{11} - P_{22}}{\partial P_{33} / \partial \ln r}$	$\frac{P_{22} - P_{33}}{\partial P_{33} / \partial \ln r}$	$\frac{P_{11} - P_{33}}{\partial P_{33} / \partial \ln r}$
	Dynes/sq. cm.						
1	-570	0	0				
2	-420	50	100		392		
3	-300	200	200				
4	-170	300	350	-570	.98	0	.98
5	-70	500	500				
6	130	700	700				
7	430	1200	1100				
8	—	—	—	—	—	—	—
9	430	1200	1100				
10	230	800	800		1.03	.025	1.01
11	-70	500	500				
12	-270	400	350				
13	-300	200	200				
14	-420	50	100				
15	-570	0	0				

TABLE NO. 14

Material: 5% Rubber/Smoked Sheet/Xylene

Rate of Shear: 93 sec.<sup>-1</sup>

Density: 0.826 gm/cc

Gauge No.	P <sub>11</sub>	P <sub>22</sub>	P <sub>33</sub>	$\frac{\partial P_{33}}{\partial \ln r}$	$\frac{P_{11} - P_{22}}{\partial P_{33} / \partial \ln r}$	$\frac{P_{22} - P_{33}}{\partial P_{33} / \partial \ln r}$	$\frac{P_{11} - P_{33}}{\partial P_{33} / \partial \ln r}$
	Dynes/sq. cm.						
1	-2060	0	0				
2	-2060	0	0	Average value	Average value	Average value	Average value
3	-1660	400	400				
4	-1400	950	800				
5	-500	1450	1500	-2060	.99	.0034	.96
6	440	2300	2400				
7	1700	3650	3700				
8	—	—	—	—	—	—	—
9	1440	3900	3700				
10	300	2450	2400				
11	-600	1500	1500		1.04	.02	1.02
12	-1300	850	800				
13	-1660	400	400				
14	-2060	0	0				
15	-2060	0	0				

TABLE NO. 15

Material: 5% Rubber/Smoked Sheet/Xylene

Rate of Shear:  $31 \text{ sec}^{-1}$ Density:  $0.826 \text{ gm/cc}$ 

Gauge No.	P <sub>11</sub>	P <sub>22</sub>	P <sub>33</sub>	$\frac{\partial P_{33}}{\partial \ln r}$	$\frac{P_{11} - P_{22}}{\partial P_{33} / \partial \ln r}$	$\frac{P_{22} - P_{33}}{\partial P_{33} / \partial \ln r}$	$\frac{P_{11} - P_{33}}{\partial P_{33} / \partial \ln r}$				
	Dynes/sq. cm.										
1	- 1340	0	0	Average Value	Average Value	Average Value	Average Value				
2	- 1340	0	0								
3	- 1150	200	200								
4	- 950	400	400								
5	- 750	600	600								
6	- 100	1550	1400								
7	1000	2500	2400								
8											
9	1200	2300	2400								
10	60	1400	1400								
11	- 800	650	600					- 1340	1.05	.0027	1.03
12	- 950	400	400								
13	- 1100	150	200								
14	- 1340	0	0								
15	- 1340	0	0								

TABLE NO. 16

Material: 5% Rubber/Smoked Sheet/Xylene

Rate of Shear:  $20 \text{ sec}^{-1}$ Density:  $0.826 \text{ gm/cc}$ 

Gauge No.	P <sub>11</sub>	P <sub>22</sub>	P <sub>33</sub>	$\frac{\partial P_{33}}{\partial \ln r}$	$\frac{P_{11} - P_{22}}{\partial P_{33} / \partial \ln r}$	$\frac{P_{22} - P_{33}}{\partial P_{33} / \partial \ln r}$	$\frac{P_{11} - P_{33}}{\partial P_{33} / \partial \ln r}$				
	Dynes/sq. cm.										
1	- 840	0	0	Average Value	Average Value	Average Value	Average Value				
2	- 840	0	0								
3	- 640	200	200								
4	- 440	400	400								
5	- 240	600	600								
6	- 100	1050	900								
7	750	1600	1600								
8											
9	860	1500	1600								
10	60	900	900								
11	- 300	650	600					- 840	1.05	.025	1.03
12	- 440	400	400								
13	- 700	250	200								
14	- 840	0	0								
15	- 840	0	0								

TABLE NO. 17

Material: 5% Rubber/Smoked Sheet/Xylene

Rate of Shear:  $5.2 \text{ sec}^{-1}$ Density:  $0.826 \text{ gm/cc}$ 

Gauge No.	$P_{11}$	$P_{22}$	$P_{33}$	$\frac{\partial P_{33}}{\partial \ln r}$	$\frac{P_{11}-P_{22}}{\partial P_{33}/\partial \ln r}$	$\frac{P_{22}-P_{33}}{\partial P_{33}/\partial \ln r}$	$\frac{P_{11}-P_{33}}{\partial P_{33}/\partial \ln r}$
	Dynes/sq. cm.						
1	-150	0	0	Average Value	Average Value	Average Value	Average Value
2	-150	0	0				
3	-200	50	0				
4	-100	50	50	-150	1.09	.05	1.05
5	-50	100	100				
6	100	150	200				
7	100	350	300				
8	—	—	—				
9	200	250	300				
10	50	200	200				
11	-50	100	100		1.00	0	1.00
12	-100	50	50				
13	-200	50	0				
14	-150	0	0				
15	-15	0	0				

TABLE NO. 18

Material: R.O.C. Sample 6726

Rate of Shear:  $104 \text{ sec}^{-1}$ Density:  $0.92 \text{ gm/cc}$ 

Gauge No.	$P_{11}$	$P_{22}$	$P_{33}$	$\frac{\partial P_{33}}{\partial \ln r}$	$\frac{P_{11}-P_{22}}{\partial P_{33}/\partial \ln r}$	$\frac{P_{22}-P_{33}}{\partial P_{33}/\partial \ln r}$	$\frac{P_{11}-P_{33}}{\partial P_{33}/\partial \ln r}$
	Dynes/sq. cm.						
1	-3700	600	700	Average Value	Average Value	Average Value	Average Value
2	-3300	1300	1250				
3	-2500	2200	2100				
4	-1500	3200	3100	-4500	1.04	.02	.99
5	-400	4300	4200				
6	1500	6200	6100				
7	4500	9600	9300				
8	—	—	—				
9	4900	9200	9300				
10	1500	6200	6100				
11	-300	4200	4200		.99	-.0048	.99
12	-1400	3100	3100				
13	-2300	2000	2100				
14	-3300	1300	1250				
15	-3700	600	700				

TABLE 19.

Materials: R.O.C. Sample 6726

Rate of Shear: 70 sec<sup>-1</sup>

Density: .92 gm/cc

Gauge No.	P <sub>11</sub>	P <sub>22</sub>	P <sub>33</sub>	$\frac{\partial P_{33}}{\partial \ln r}$	$\frac{P_{11}-P_{22}}{\partial P_{33}/\partial \ln r}$	$\frac{P_{22}-P_{33}}{\partial P_{33}/\partial \ln r}$	$\frac{P_{11}-P_{33}}{\partial P_{33}/\partial \ln r}$
	Dynes/sq. cm.						
1	-2000	400	600	Average Value	Average Value	Average Value	Average Value
2	-1850	700	800				
3	-1350	1400	1400				
4	-550	1800	2000	-2750	1.01	.005	1.01
5	-250	2900	2700	—	—	—	—
6	950	3900	3800	—	—	—	—
7	2650	6000	5700	—	—	—	—
8	—	—	—	—	—	—	—
9	3150	5500	5700	—	—	—	—
10	1150	3700	3800	—	—	—	—
11	-50	2700	2700	—	.95	.0023	.98
12	-700	1950	2000	—	—	—	—
13	-1250	1300	1400	—	—	—	—
14	-1950	800	800	—	—	—	—
15	-2350	400	400	—	—	—	—

TABLE 20.

Material: R.O.C. Sample 6726

Rate of Shear: 50 sec<sup>-1</sup>

Density: 0.92 gm/cc

Gauge	P <sub>11</sub>	P <sub>22</sub>	P <sub>33</sub>	$\frac{\partial P_{33}}{\partial \ln r}$	$\frac{P_{11}-P_{22}}{\partial P_{33}/\partial \ln r}$	$\frac{P_{22}-P_{33}}{\partial P_{33}/\partial \ln r}$	$\frac{P_{11}-P_{33}}{\partial P_{33}/\partial \ln r}$
	Dynes/sq. cm.						
1	-1100	200	200	Average Value	Average Value	Average Value	Average Value
2	-900	400	400				
3	-700	600	600				
4	-400	900	900	-1300	1.1	.044	1.04
5	-300	1200	1100	—	—	—	—
6	300	1800	1700	—	—	—	—
7	1100	2800	2600	—	—	—	—
8	—	—	—	—	—	—	—
9	1300	2600	2600	—	—	—	—
10	400	1700	1700	—	—	—	—
11	-250	1150	1100	—	.97	-.01	.98
12	-400	900	900	—	—	—	—
13	-600	500	600	—	—	—	—
14	-850	350	400	—	—	—	—
15	-1100	200	200	—	—	—	—

TABLE 21

Material: R.O.C. Sample 6726

Rate of Shear: 31 sec<sup>-1</sup>

Density: 0.92 gm/cc

Gauge No.	P <sub>11</sub>	P <sub>22</sub>	P <sub>33</sub>	$\frac{\partial P_{33}}{\partial \ln r}$	$\frac{P_{11}-P_{22}}{\partial P_{33} / \partial \ln r}$	$\frac{P_{22}-P_{33}}{\partial P_{33} / \partial \ln r}$	$\frac{P_{11}-P_{33}}{\partial P_{33} / \partial \ln r}$
	Dynes/sq. cm						
1	-230	0	0	Average value	Average value	Average value	Average value
2	-130	100	100				
3	-180	150	100				
4	-180	150	100				
5	-30	200	200	-230	1.12	.06	1.06
6	270	300	400				
7	270	700	600				
8	—	—	—	—	—	—	—
9	370	600	600				
10	270	300	400				
11	-30	200	200		1.06	.031	1.03
12	-230	200	100				
13	-180	150	100				
14	-130	100	100				
15	-230	0	0				

## APPENDIX I

Note on Capillary Gauges

There are obvious advantages in the use of capillary gauges for the measurement of the normal pressure exerted by a flowing liquid at various points at a solid boundary. The gauges of this type are simple in construction and can be used as direct reading instruments once the equilibrium has been established. They then cause very little local disturbance to the flow at the point of measurement as the liquid in the gauge is held almost stationary by the capillary walls and thus provides conditions similar to those of the adjoining solid surface at the base of the capillary.

However certain precautions have to be taken to avoid a misinterpretation of the readings taken in this type of gauge.

- (i) There is a considerable delay particularly with liquids of high viscosity before the equilibrium level in the capillary is established as the liquid has to flow in the capillary.
- (ii) Surface tension has to be allowed for which alters the height and the levelness of the liquid in the capillary.
- (iii) The finite size of the base of each gauge allows only the recording of an average value of the pressures exerted at the various points of the base and this makes it difficult to assess the exact value of the pressure at any one point, particularly when there is an appreciable variation of the pressure within the area of the base.

Note: By calculating the averages over these areas it was found that the pressure centre was displaced from the tube centre towards the axis of the torque by amounts which were negligible at the periphery but gave up to some 8% for the tube adjacent to the centre. The reading of the centre tube was not taken because the flow conditions at the bottom of that tube were not sufficiently well defined.

Taking this into account readings were obtained in the capillary gauges reliable to an accuracy of 5% or less for the average values over the area of the base. The worst conditions were encountered in the cone plate experiments for the capillary gauge mounted opposite to the apex of the cone. Here the pressure changed greatly within the area of the base (for a disturbance in the effective gap size of .001" gave an estimated error in pressure change of some 200% to 300%), while under ideal conditions the pressure at the centre should approach an infinitely larger value, the average value over the base area will be given by  $\pi x^2 (P_{11}(R) \log R/r + \frac{1}{2})$  where  $x$  is the radius of the capillary and  $P_{11} = P_{33} - P_{11}$ .

## APPENDIX II

The Normal Pressure across the Interface between a Standard Liquid and a General One.

The interface had to be always a surface in an orientation parallel to the lines of flow and somewhere between the planes No. 3 and No. 2. It was possible to calculate for any such orientation the normal pressure across the interface from the general equations (4a), (4c) and (4d). It was found that the normal pressure ( $P_N$ ) on a plane of arbitrary orientation was given by

$$P_N = P_{11}v_1^2 + P_{22}v_2^2 + P_{33}v_3^2 + 2P_{12}v_1v_2$$

which simplified for the orientations envisaged for the interface

$$(v_1^2 = 0, \text{ and } v_2^2 + v_3^2 = 1) \text{ to}$$

$$P_N = P_{22} + (P_{33} - P_{22})v_3^2$$

The experimental result of an equality between  $P_{22}$  and the normal pressure  $P_N$  across the interface then meant

$$P_{22} = P_{22} + (P_{33} - P_{22})v_3^2 \text{ and hence}$$

$$P_{33} = P_{22}$$

as  $v_3^2$  was different from zero.

## APPENDIX III

The Equilibrium of Forces

The principle of equilibrium of forces required for a differential cell a balance between the forces of inertia and gravity acting on the mass of the cell and the traction forces acting on the surface. The conditions of equilibrium have been formulated in various systems of coordinates\*. For a Cartesian system of coordinates  $(x_1, x_2, x_3)$  the equations

$$\frac{\partial P_{1k}}{\partial x_1} + \frac{\partial P_{2k}}{\partial x_2} + \frac{\partial P_{3k}}{\partial x_3} + i_k + g_k = 0$$

$$i_k = 0 \quad \left( \begin{array}{l} \text{o, g, o for horizontal gap} \\ \text{o, g sin } \beta, \text{ g cos } \beta \text{ for inclined gap with} \\ \text{half opening angle.} \end{array} \right)$$

were found, as the traction forces acting on one pair of (j) faces, had along the (k) direction a resultant equal to  $\frac{\partial P_{jk}}{\partial x_j}$  per unit volume

and the forces of inertia ( $i_k$ ) had been kept negligibly small, while the forces of gravity ( $g_k$ ) were in the horizontal gap along the No. 2 direction and in the inclined gap along a direction with direction cosines given by  $\beta$ .

The transformation from Cartesian to Spherical polar coordinates  $(\rho, \beta, \psi)$  gave

$$0 = \frac{1}{\rho^2} \frac{\partial}{\partial \rho} (P_{33} \rho^2) + \frac{1}{\rho \sin \beta} \frac{\partial}{\partial \beta} (P_{23} \sin \beta + \frac{1}{\rho \sin \beta} \frac{\partial P_{13}}{\partial \psi} - \frac{1}{\rho} (P_{22} + P_{11})) + i_\rho + g_\rho$$

$$0 = \frac{1}{\rho^3} \frac{\partial}{\partial \rho} (P_{23} \rho^3) + \frac{1}{\rho \sin \beta} \frac{\partial}{\partial \beta} (P_{22} \sin \beta) + \frac{1}{\rho \sin \beta} \frac{\partial P_{12}}{\partial \psi} - \frac{P_{11} \cos \beta}{\rho \sin \beta} + i_\beta + g_\beta$$

$$0 = \frac{1}{\rho^3} \frac{\partial}{\partial \rho} (P_{31} \rho^3) + \frac{1}{\rho \sin^2 \beta} \frac{\partial}{\partial \beta} (P_{12} \sin^2 \beta) + \frac{1}{\rho \sin \beta} \frac{\partial P_{11}}{\partial \psi} + i_\psi + g_\psi$$

The equations applied to conical gaps of small width.

In consideration of (4c) (4g) then

$$\frac{\partial P_{33}}{\partial \ln \rho} - (P_{11} + P_{22}) + 2P_{33} = -G_\rho(\rho, \beta, \psi)$$

$$\frac{\partial P_{22}}{\rho \partial \beta} + (P_{22} - P_{11}) \frac{\cos \beta}{\sin \beta} = -G_\beta(\rho, \beta, \psi)$$

$$\frac{\partial P_{12}}{\rho \partial \beta} + 2P_{12} \frac{\cos \beta}{\rho \sin \beta} = -G_\psi(\rho, \beta, \psi)$$

where  $G_\alpha(\rho, \beta, \psi)$  denoted at the point  $(\rho, \beta, \psi)$  the  $(\alpha)$  component of the gravity head (for  $\alpha = \rho, \beta, \psi$ ), and this component was zero in the horizontal gap for  $\alpha = \rho$  and  $\alpha = \psi$ , and in the inclined gap for  $\alpha = \psi$  only.

For all the gaps the first equilibrium equation only had to be considered, since the second and third equations were always trivially fulfilled for the horizontal gaps, because of (4f) and (4g), while for the inclined gap the variation of the pressure components with  $\beta$  which appear in these equations was not studied.

\* See W. C. Ibbetson, Math. Theory of Elasticity, MacMillan & Co., London and N.Y. 1887.

## APPENDIX IV

inclined gap the variation of the pressure components with  $\beta$  which appear in these equations was not studied.

Change in the rate of shear in the Conical Gaps

In conical gaps there is a change in the rate of shear depending on the angle of the cone and on the angular width of the gap as shown below.

The motion in a gap is controlled by the equilibrium between the torque ( $T_1$ ) of the fixed cone or flat plate and the torque ( $T_2$ ) of the rotating cone.

$$\text{i.e. } T_1 = T_2$$

$$\text{where } T_1 = \int_{r=0}^{r=R} P_{12} \rho \pi r^2 \frac{\delta r}{\sin \theta} = \frac{2}{3} \pi R^3 P_{12} \sin^2 \theta$$

$$\text{similarly } T_2 = \frac{2}{3} \pi R^3 (P_{12} + \delta P_{12}) \sin^2(\theta + \delta \theta)$$

$$\text{so that } \frac{\delta P_{12}}{P_{12}} = -2 \cot \theta \delta \theta$$

The shearing pressures on the two boundary platens were then deduced from this equilibrium equation between the angles  $\theta_1$  and  $\theta_2$  of the boundary cones which gave

$$\frac{P_{12}(\theta_1)}{P_{12}(\theta_2)} = \frac{\sin^2 \theta_2}{\sin^2 \theta_1}$$

for the cone/flat plate ( $\theta_1 = 90$  and  $\theta_2 = 94$  for a  $4^\circ$  cone).

$$\frac{P_{12}(\theta_1)}{P_{12}(\theta_2)} = .995$$

for the cone/cone ( $\theta_1 = 44$ ,  $\theta_2 = 46$  for a  $20$  gap).

$$\frac{P_{12}(\theta_1)}{P_{12}(\theta_2)} = 1.074$$

and for a cone/cone of  $44/44\frac{1}{2}$  i.e.  $\frac{1}{2}^\circ$  gap

$$\frac{P_{12}(\theta_1)}{P_{12}(\theta_2)} = 1.018$$

For Newtonian liquids the changes in the rate of shear are proportional to those of the shearing stress so that

$$\text{for the flat plate/cone } \frac{c_1}{c_2} = .995 \text{ for } 4^\circ \text{ gap}$$

$$\text{for the cone/cone of } \frac{1}{2}^\circ \text{ gap } \frac{c_1}{c_2} = 1.018$$

The above results apply approximately (2%) to the non-Newtonian liquids investigated since for these liquids the changes in apparent viscosity were only fractions of the changes in the shear stress.

MAIN APPARATUS

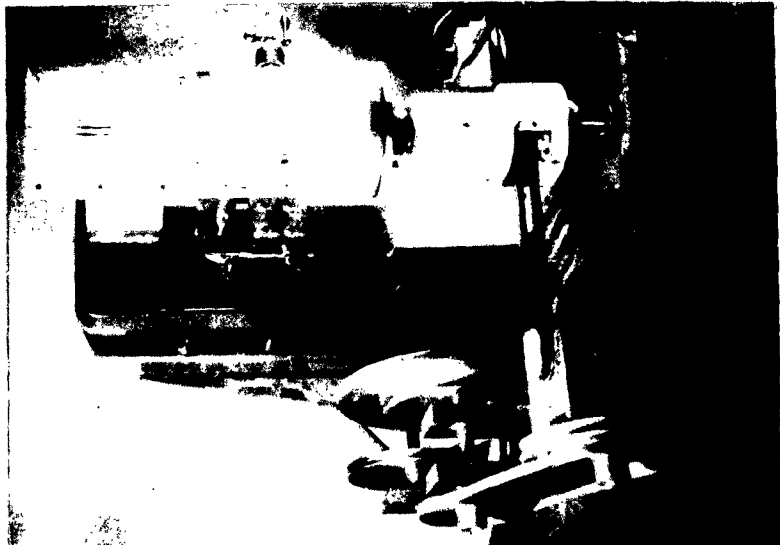

ARMAMENT DESIGN ESTD. N. OF S.  
FIG. 1<sup>A</sup>



ARMAMENT DESIGN ESTD. N. OF S.  
FIG. 1<sup>B</sup>

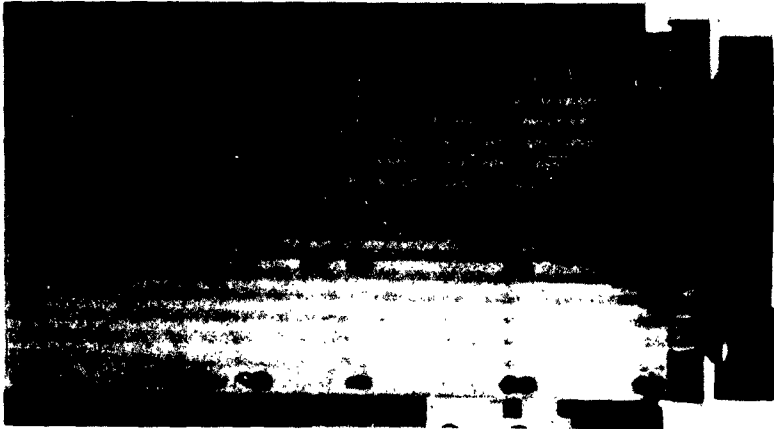

ARMAMENT DESIGN ESTD. N. OF S.  
FIG. 1<sup>C</sup>

# RESOLUTION OF PRESSURES AT A POINT IN LAMINAR SHEARING MOTION.

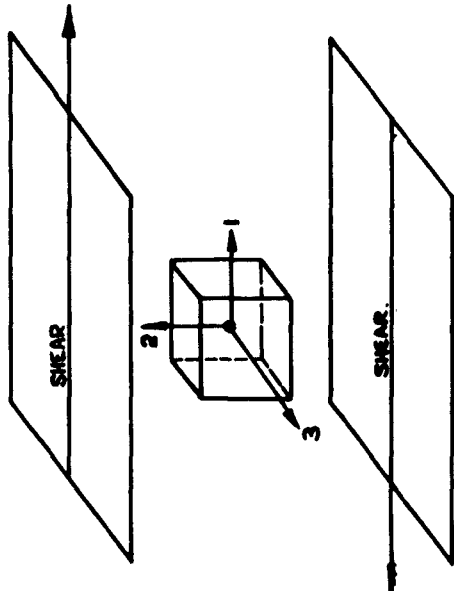

$$P = \begin{vmatrix} P_{11} & P_{12} & 0 \\ P_{21} & P_{22} & 0 \\ 0 & 0 & P_{33} \end{vmatrix} \quad \text{WITH } P_{12} = P_{21}$$

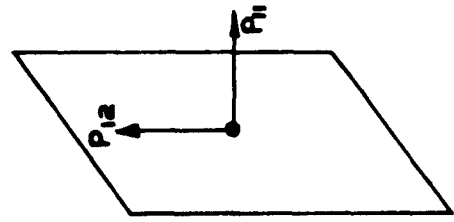

No. 1 PLANE.

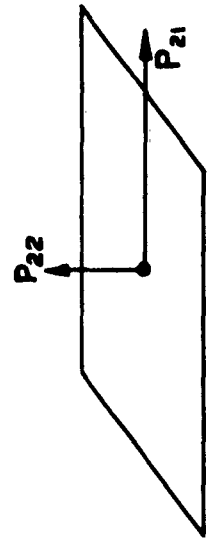

No. 2 PLANE.

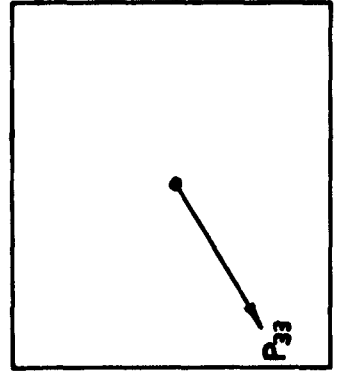

No. 3 PLANE.

FIG. 2

# CO-ORDINATE SYSTEMS FOR HORIZONTAL GAP APPARATUS.

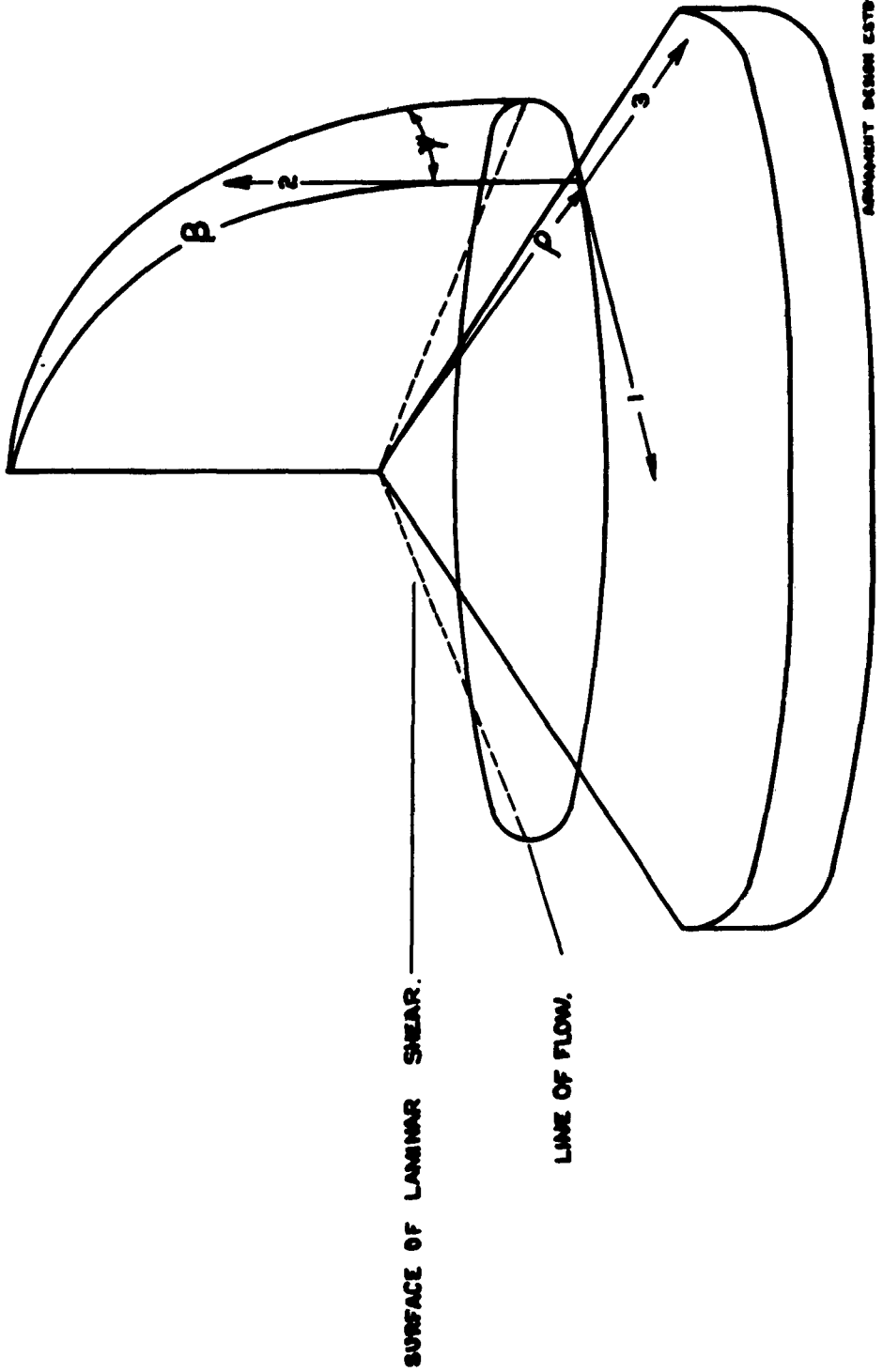

FIG. 3.

ADAPMENT DESIGN ESTBY M. OF S.

FIGS. 4<sub>a</sub>-4<sub>c</sub>.  
 CAPILLARY MEASURING APPARATUS.

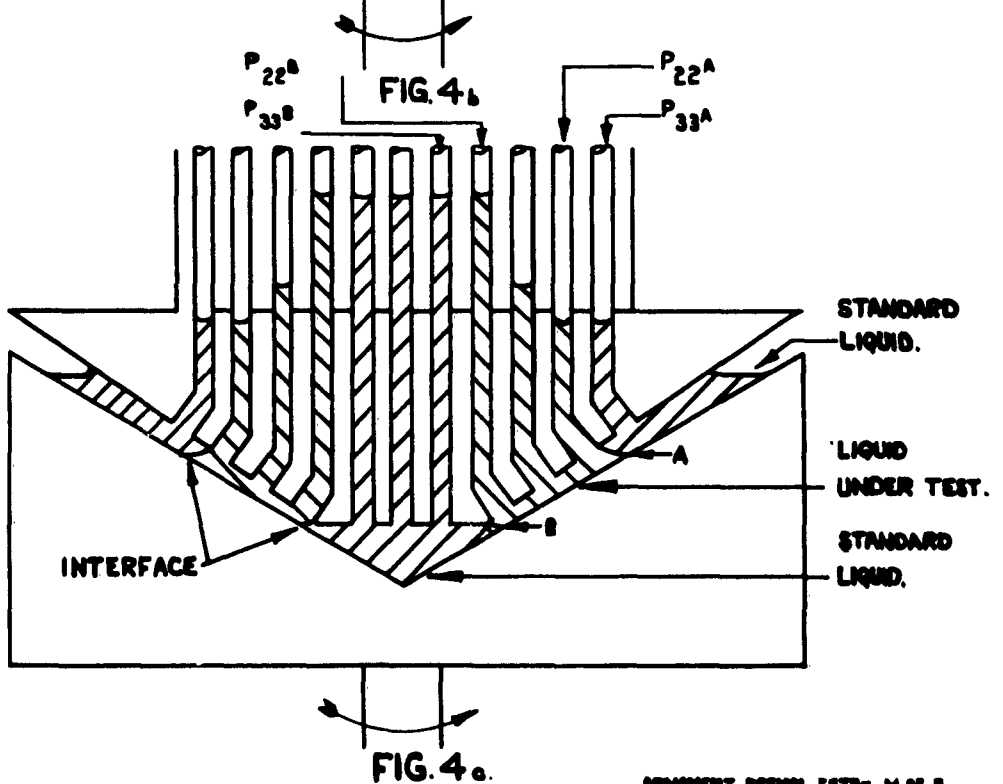
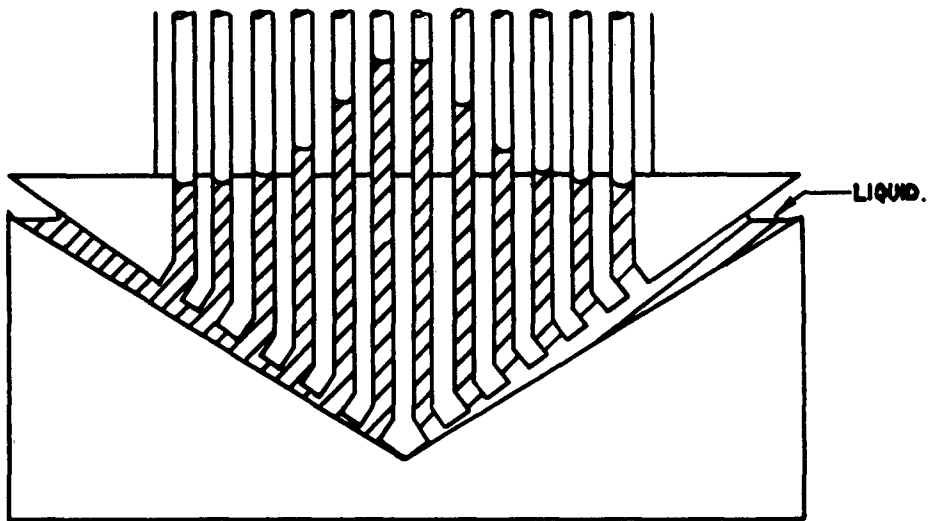
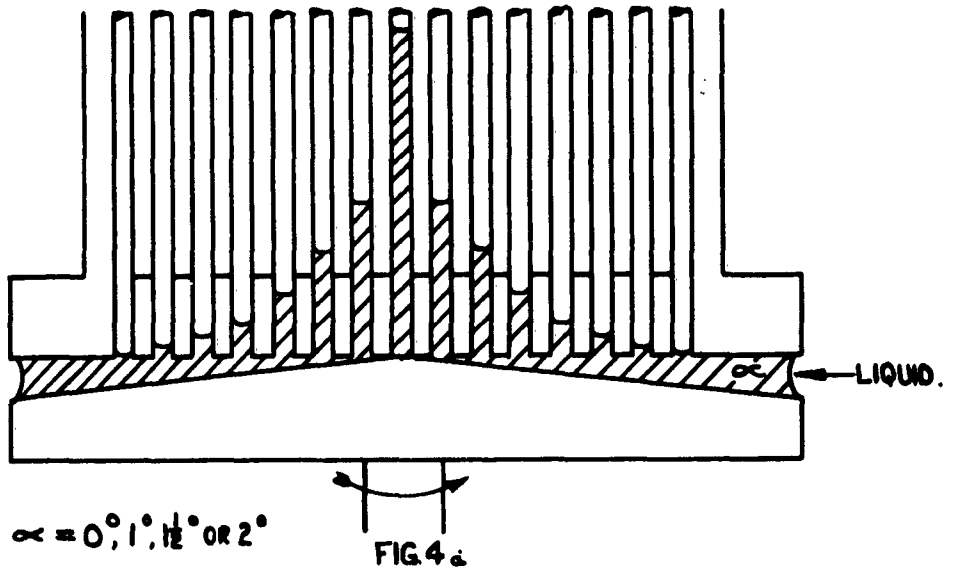
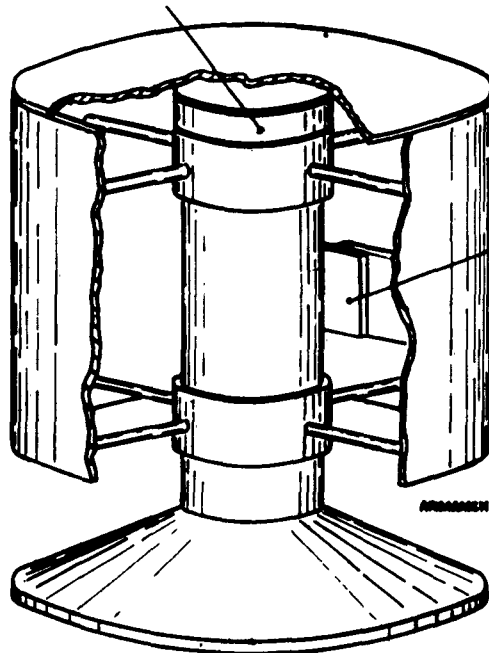

DIAGRAM OF TORQUE AND THRUST APPARATUS.

CONDENSER FOR MEASURING  
AXIAL THRUST.

CONDENSER FOR  
MEASURING TORQUE



ARRANGEMENT DESIGN ESTD. M. OF S.

COMPARISON BETWEEN EXPERIMENTAL RESULTS (X) AND THEORIES.—

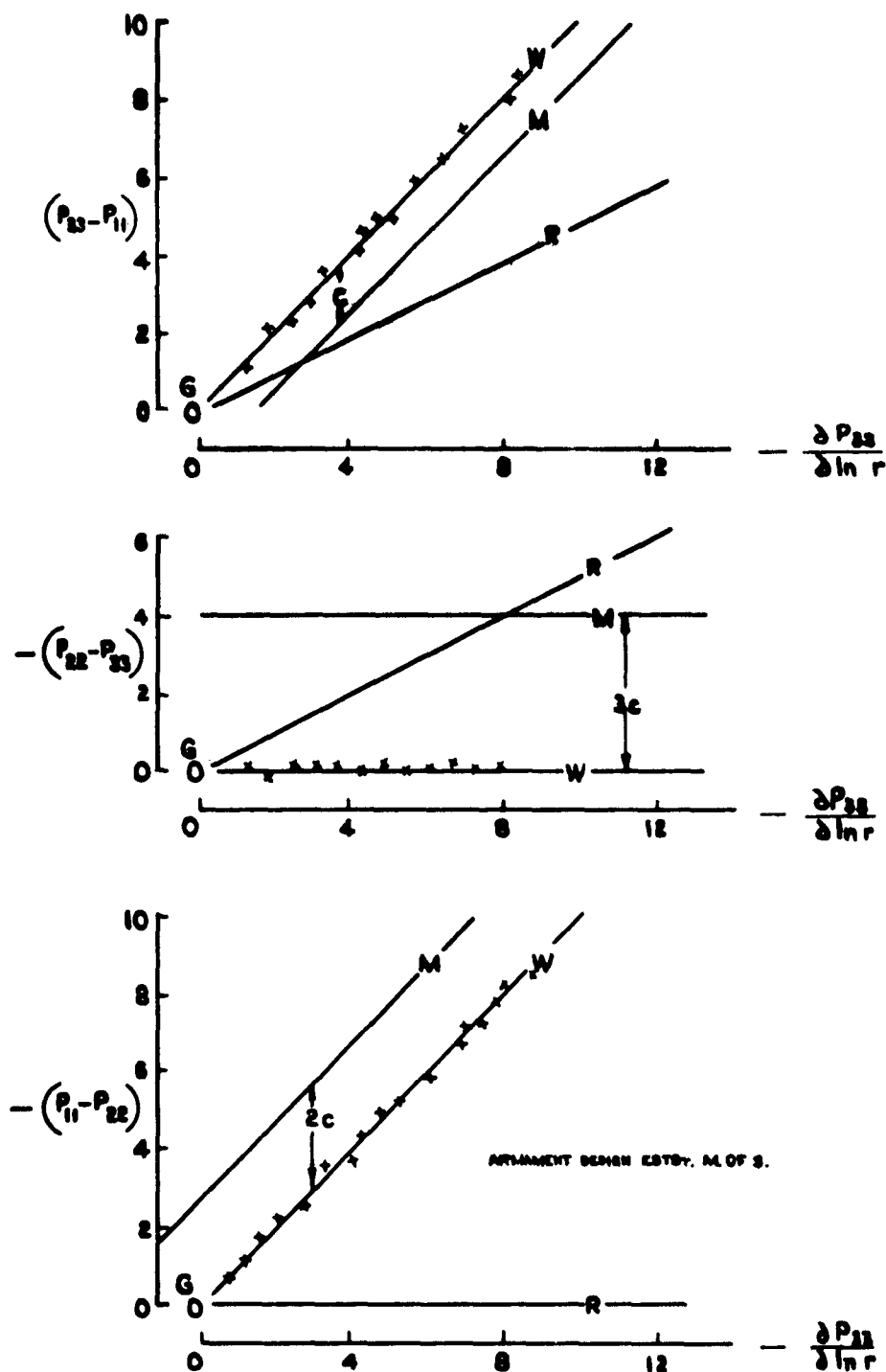

ALL PRESSURES MEASURED IN DYNES PER SQ. CM. X  $10^3$ .

- W (WEISSENBURG):  $-\frac{\partial P_{33}}{\partial \ln r} = (P_{33} - P_{11}) = (P_{22} - P_{11})$
- R (REINER & RIVLIN):  $-\frac{\partial P_{33}}{\partial \ln r} = 2(P_{33} - P_{22}) = 2(P_{33} - P_{11})$
- G (GARNER, NISSAN & WOOD):  $-\frac{\partial P_{33}}{\partial \ln r} = (P_{33} - P_{11}) = (P_{22} - P_{33}) = (P_{11} - P_{22}) = 0$ .
- M (MOONEY):  $-\frac{\partial P_{33}}{\partial \ln r} = (P_{33} - P_{11}) - c = (P_{22} - P_{11}) + 2c$  WHERE  $c = \text{CONST. (G-M)}$ .

# DISTRIBUTION OF PRESSURE $P_{22}$ WITH RESPECT TO RADIUS

RATE OF SHEAR - 32  
MATERIAL - 3% AL. LAURATE / T.V.O.

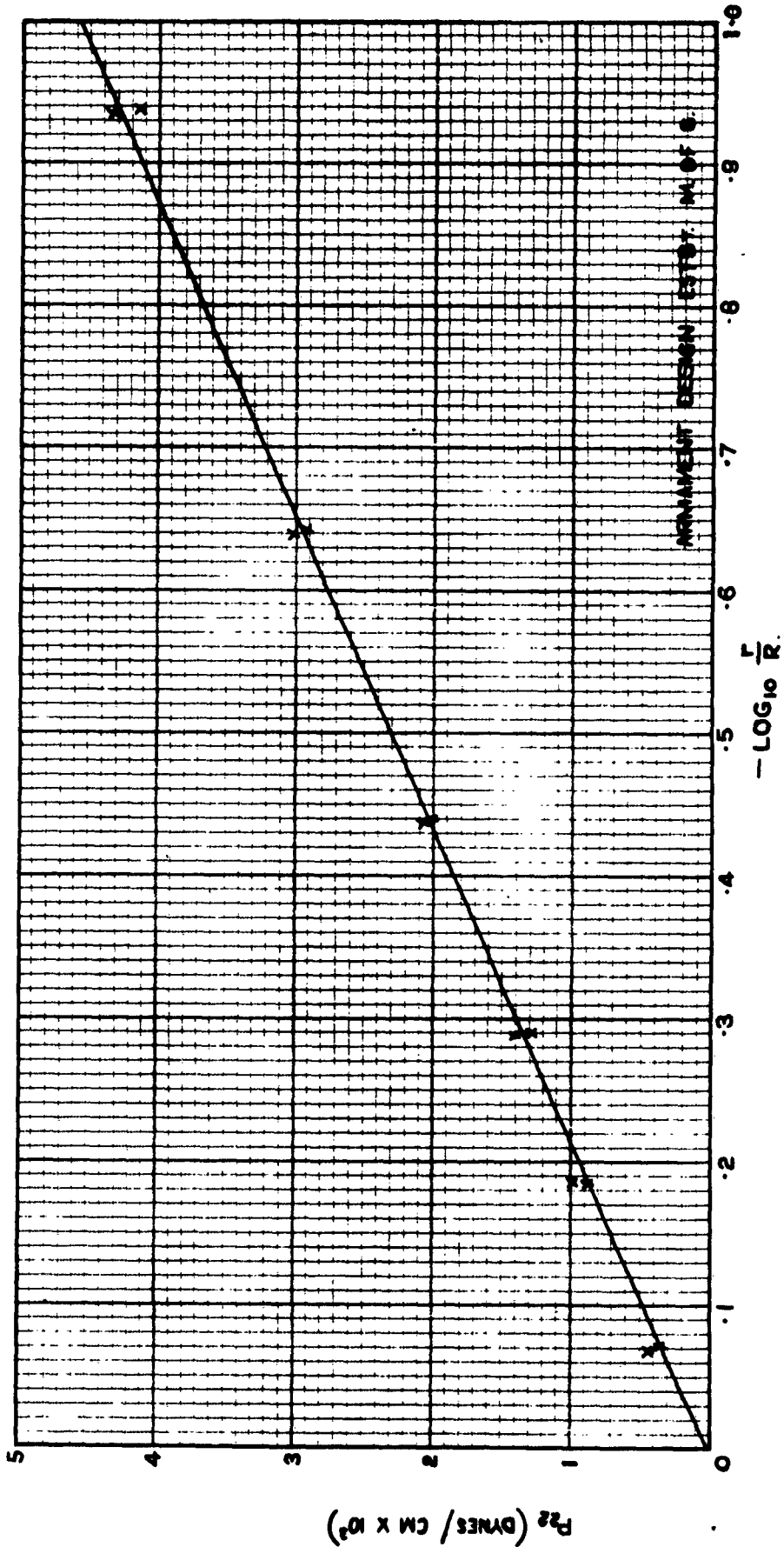

FIG 7

DISTRIBUTION OF PRESSURE  $P_{22}$  WITH RESPECT TO RADIUS  
 FOR VARIOUS PRESSURE OF  $P_{23}$  AT THE RM.

RATE OF SHEAR - 30  
 MATERIAL - 3% AL LAURATE.

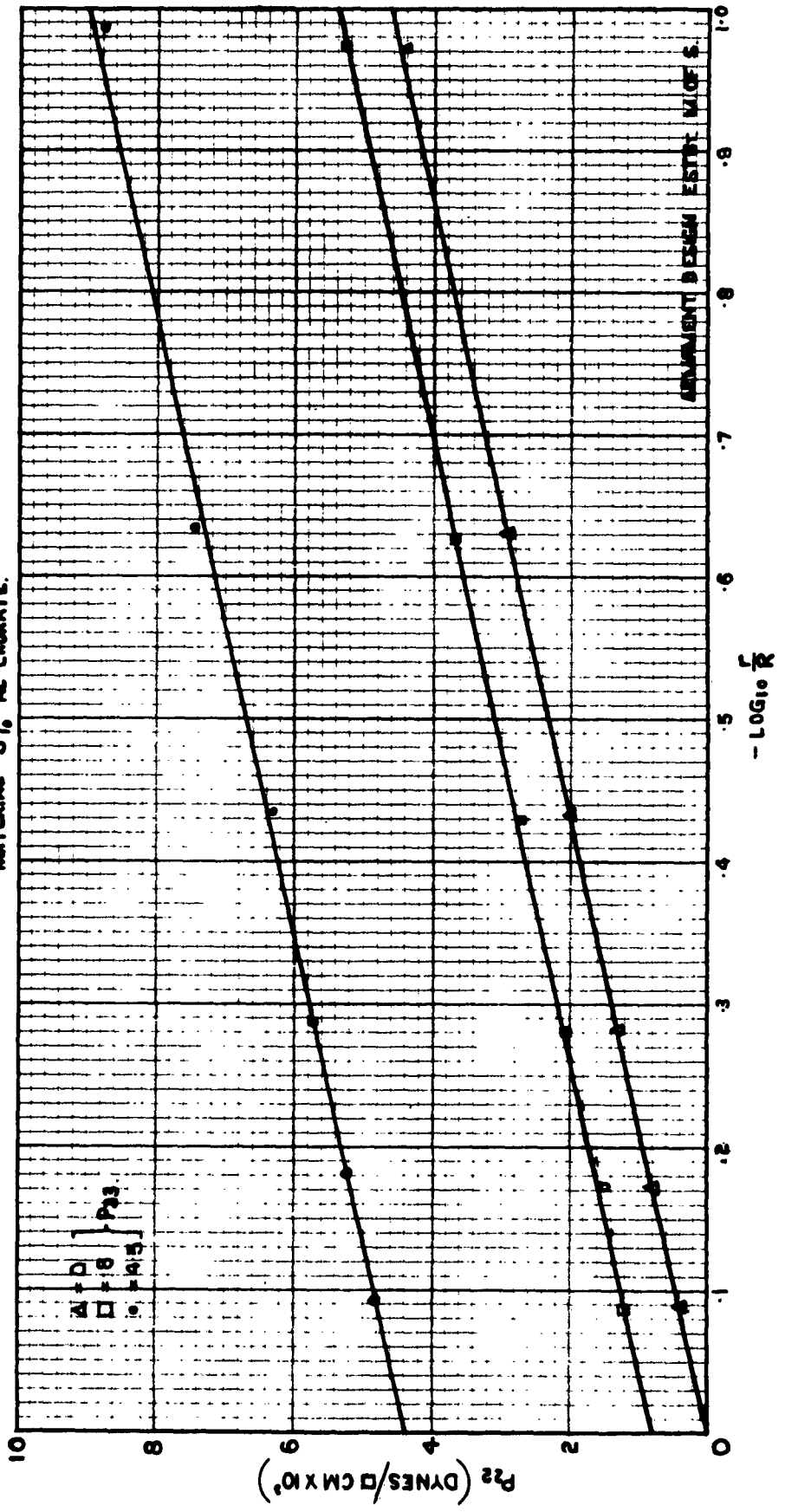
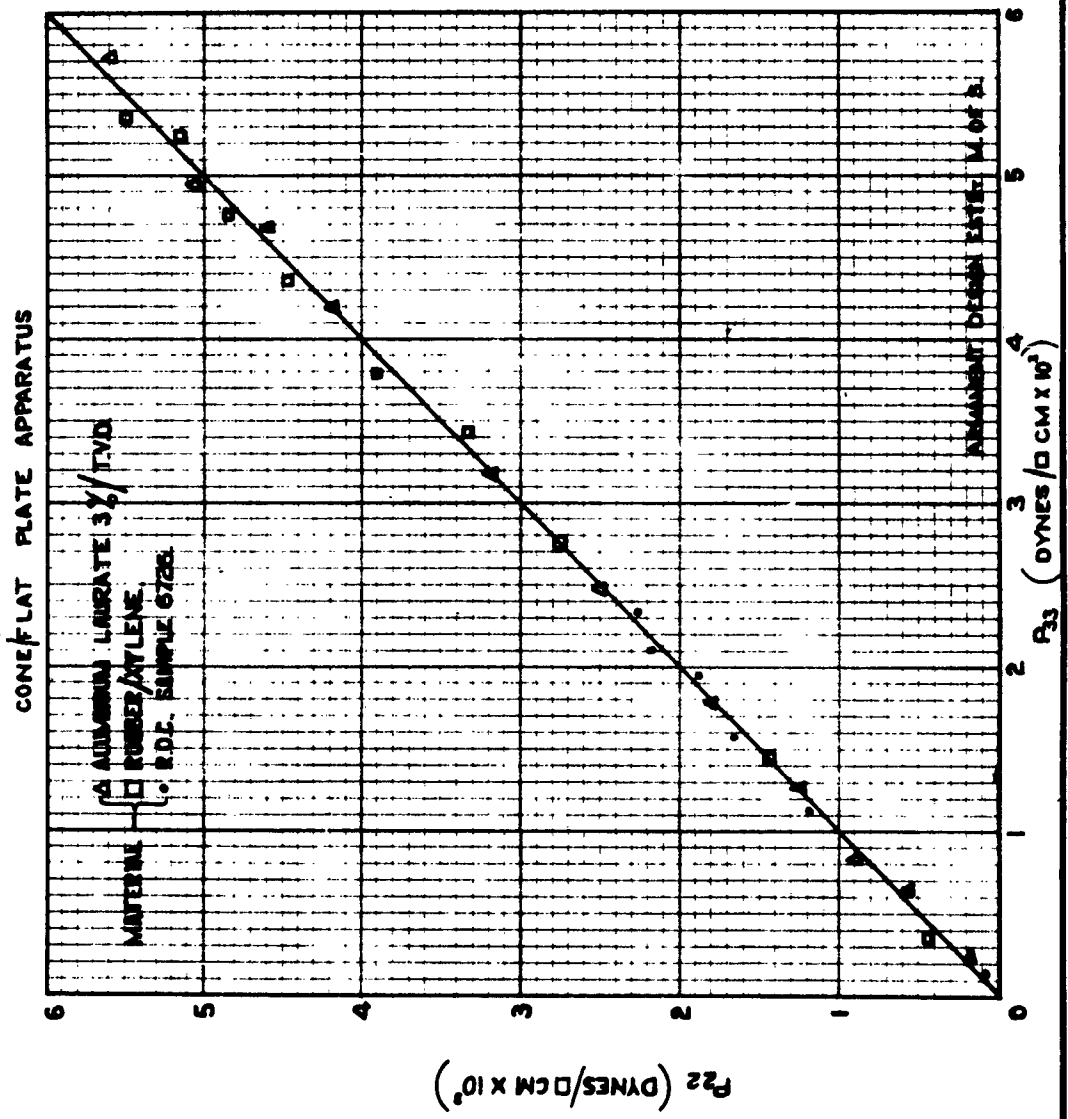

FIG. 8.

FIG. 9.

COMPARISON OF PRESSURE  $P_{22}$  AND PRESSURE  $P_{33}$  AT INTERFACE.



# DEPENDENCY OF PRESSURE $P_{22}$ ON RADIUS.

APPARATUS - 1° CONE.

MATERIAL 3% ALUMINUM LAURATE.

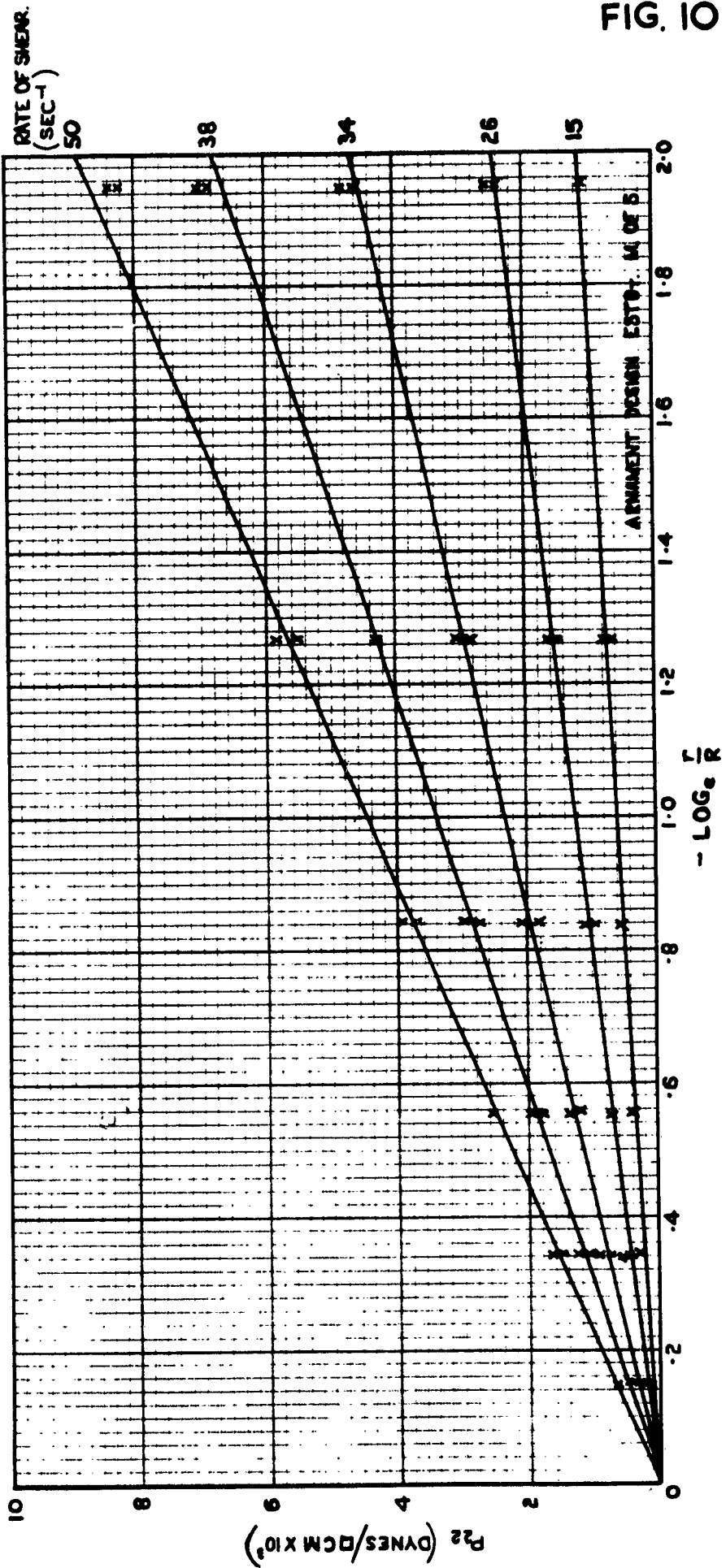

FIG. 10

# DEPENDENCY OF PRESSURE $P_{22}$ ON RADIUS

APPARATUS - 1" CONE.  
MATERIAL - 5% RUBBER.

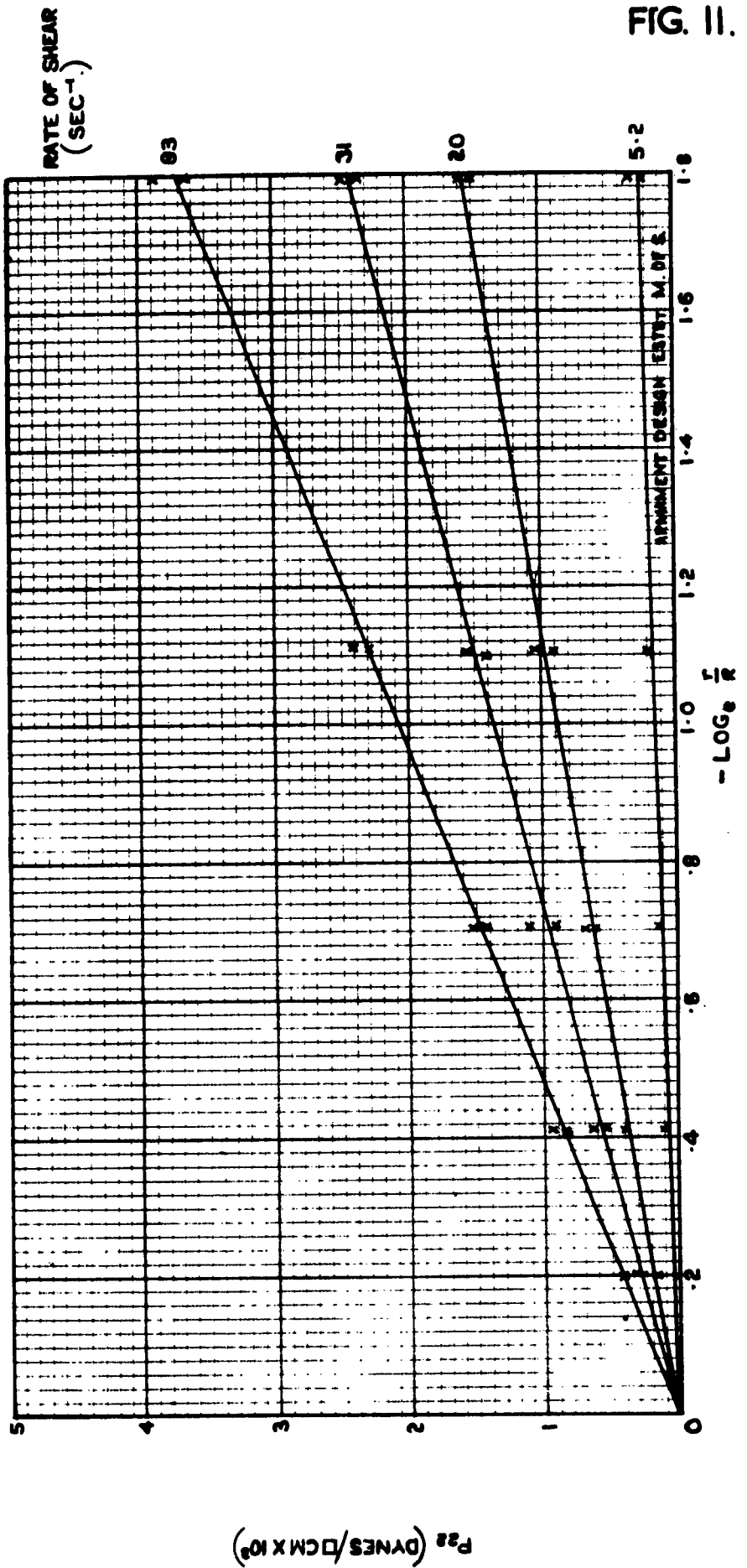

FIG. II.

# DEPENDENCY OF PRESSURE $P_{22}$ ON RADIUS

APPARATUS -  $1^\circ$  CONE.

MATERIAL - R.O.C. SAMPLE 6726.

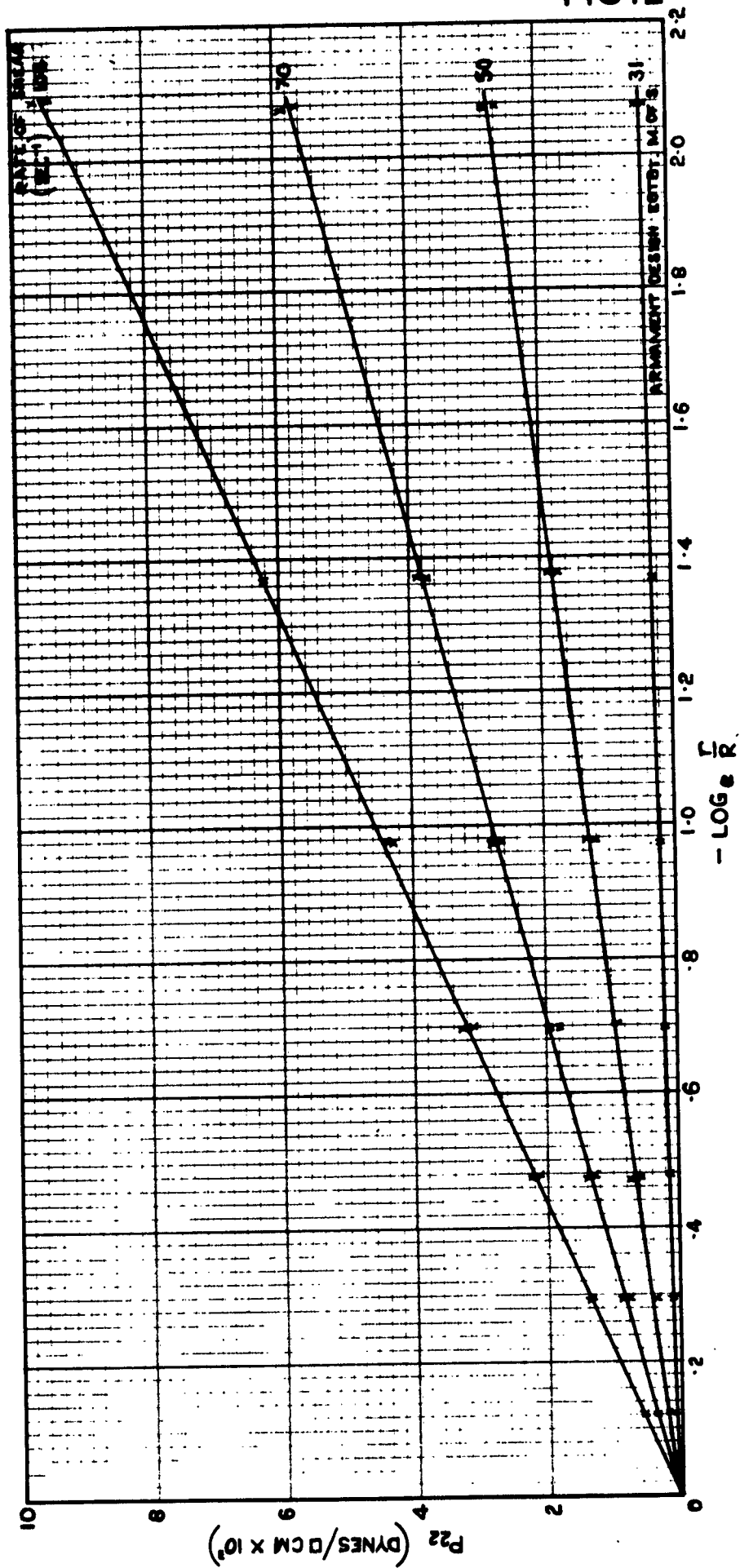

FIG 12

NORMAL PRESSURE V. RATE OF SHEAR.

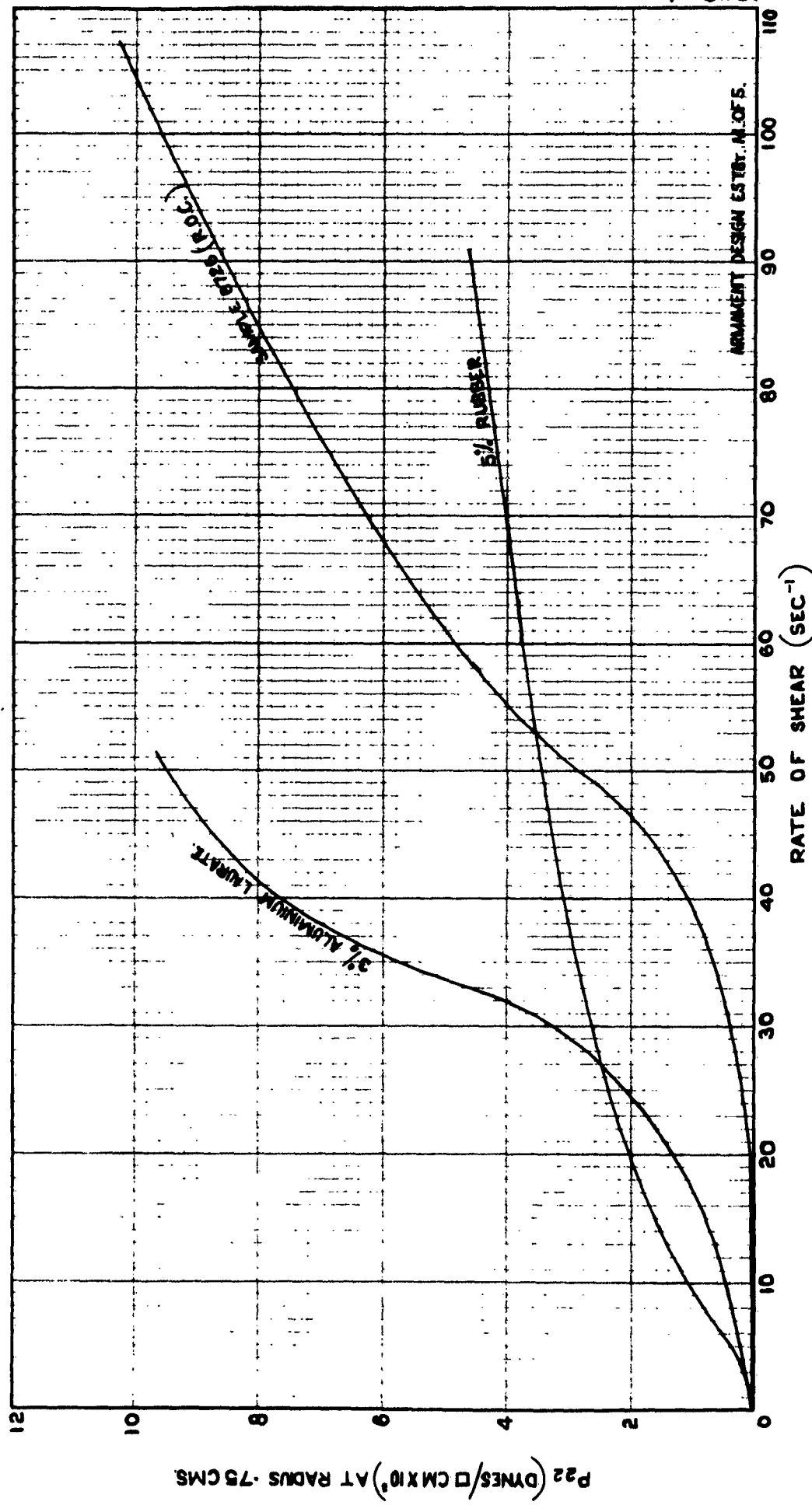

FIG. 13.

ARMAMENT DESIGN ESTBL. N. O. S.

# DEPENDENCY OF PRESSURE $P_{12}$ ON RATE OF SHEAR.

MATERIAL - 3% ALUMINIUM LAURATE/TVO.

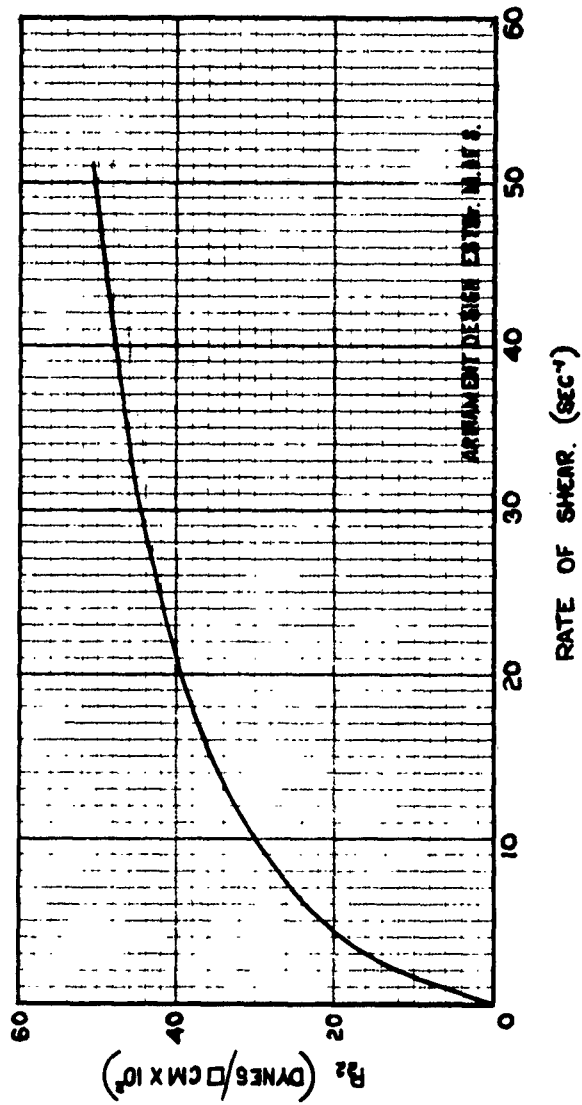
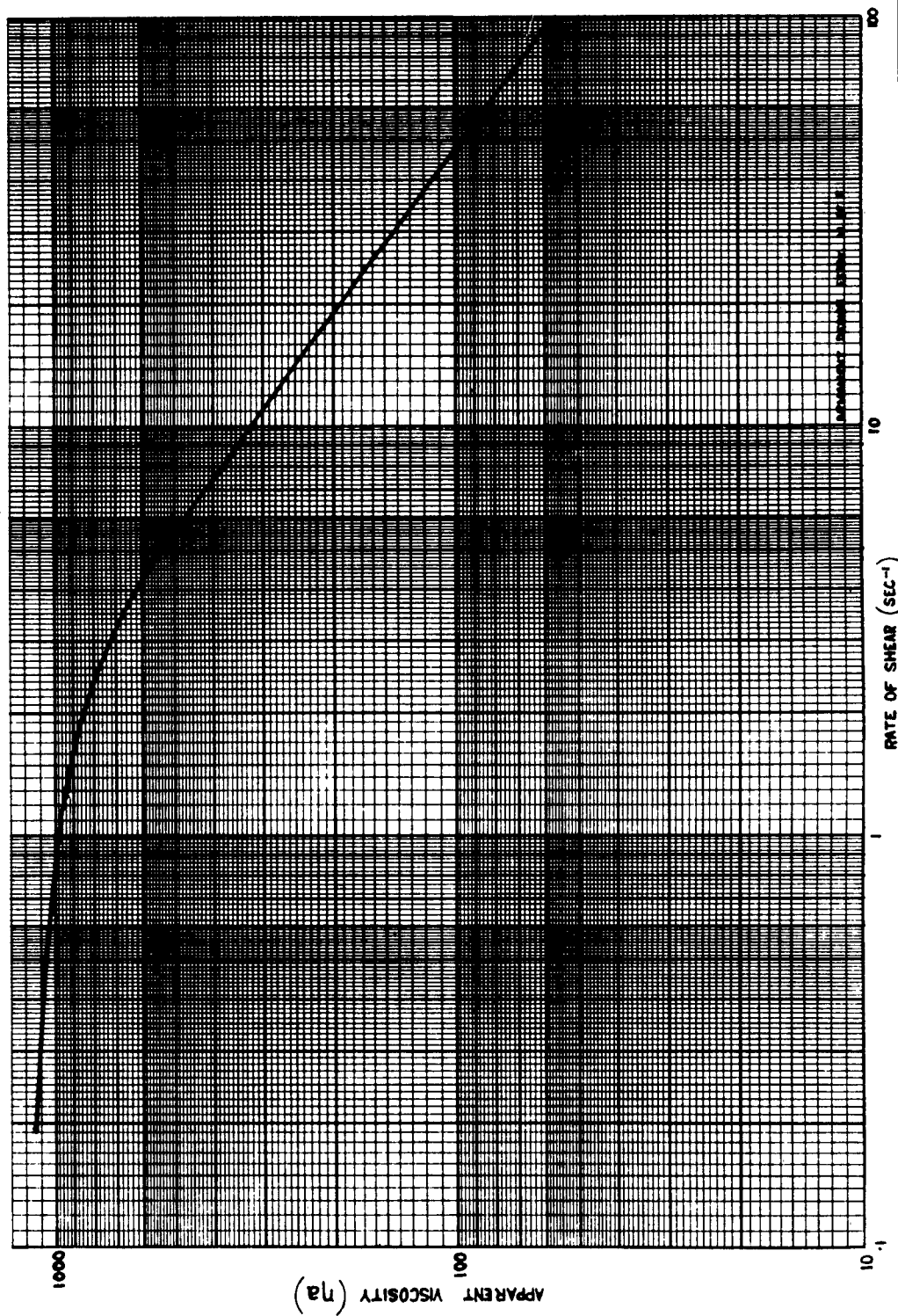

FIG. 14

FIG. 15

DEPENDENCY OF VISCOSITY ON RATE OF SHEAR.

MATERIAL - 3% AL. LAURATE / T.V.O.





*Information Centre  
Knowledge Services*  
**[dstl]** Porton Down,  
Salisbury  
Wiltshire  
SP4 0JQ  
22060-6218  
Tel: 01980-613753  
Fax 01980-613970

Defense Technical Information Center (DTIC)  
8725 John J. Kingman Road, Suit 0944  
Fort Belvoir, VA 22060-6218  
U.S.A.

AD#: AD029527

Date of Search: 30 April 2008

Record Summary: DEFE 15/330

Title: Pressure Distribution in Liquids in Laminar Shearing Motion and Comparison with Predictions from Various Theories  
Availability Open Document, Open Description, Normal Closure before FOI Act: 30 years  
Former reference (Department) Technical Report No 13/52  
Held by The National Archives, Kew

This document is now available at the National Archives, Kew, Surrey, United Kingdom.

DTIC has checked the National Archives Catalogue website (<http://www.nationalarchives.gov.uk>) and found the document is available and releasable to the public.

Access to UK public records is governed by statute, namely the Public Records Act, 1958, and the Public Records Act, 1967. The document has been released under the 30 year rule. (The vast majority of records selected for permanent preservation are made available to the public when they are 30 years old. This is commonly referred to as the 30 year rule and was established by the Public Records Act of 1967).

**This document may be treated as UNLIMITED.**