

UNCLASSIFIED

AD NUMBER
AD029866
NEW LIMITATION CHANGE
TO Approved for public release, distribution unlimited
FROM Distribution authorized to U.S. Gov't. agencies and their contractors; Foreign Government Information; OCT 1953. Other requests shall be referred to British Embassy, 3100 Massachusetts Avenue, NW, Washington, DC 20008.
AUTHORITY
DSTL, AVIA 6/19107, 10 Jul 2008

THIS PAGE IS UNCLASSIFIED

Armed Services Technical Information Agency

Because of our limited supply, you are requested to return this copy WHEN IT HAS SERVED YOUR PURPOSE so that it may be made available to other requesters. Your cooperation will be appreciated.

AD

29866

NOTICE: WHEN GOVERNMENT OR OTHER DRAWINGS, SPECIFICATIONS OR OTHER DATA ARE USED FOR ANY PURPOSE OTHER THAN IN CONNECTION WITH A DEFINITELY RELATED GOVERNMENT PROCUREMENT OPERATION, THE U. S. GOVERNMENT THEREBY INCURS NO RESPONSIBILITY, NOR ANY OBLIGATION WHATSOEVER; AND THE FACT THAT THE GOVERNMENT MAY HAVE FORMULATED, FURNISHED, OR IN ANY WAY SUPPLIED THE SAID DRAWINGS, SPECIFICATIONS, OR OTHER DATA IS NOT TO BE REGARDED BY IMPLICATION OR OTHERWISE AS IN ANY MANNER LICENSING THE HOLDER OR ANY OTHER PERSON OR CORPORATION, OR CONVEYING ANY RIGHTS OR PERMISSION TO MANUFACTURE, USE OR SELL ANY PATENTED INVENTION THAT MAY IN ANY WAY BE RELATED THERETO.

Reproduced by
DOCUMENT SERVICE CENTER
KNOTT BUILDING, DAYTON, 2, OHIO

UNCLASSIFIED

TECH. NOTE
PH.479

TECH. NOTE
PH.479

ROYAL AIRCRAFT ESTABLISHMENT
F A R N B O R O U G H , H A N T S

TECHNICAL NOTE: No. PH.479

**EXPERIMENTAL WORK
ON THE ELECTROSTATIC
CHARGES FORMED ON
AIRCRAFT CAMERA FILM**

by

J.A.WELLS, A.F.R.Ae.S.

M I N I S T R Y  O F S U P P L Y

THIS DOCUMENT IS THE PROPERTY OF H.M. GOVERNMENT AND
ATTENTION IS CALLED TO THE PENALTIES ATTACHING TO
ANY INFRINGEMENT OF THE OFFICIAL SECRETS ACT, 1911-1939

It is intended for the use of the recipient only, and for communication to such officers under him as may require to be acquainted with its contents in the course of their duties. The officers exercising this power of communication are responsible that such information is imparted with due caution and reserve. Any person other than the authorised holder, upon obtaining possession of this document, by finding it otherwise, should forward it, together with his name and address, in a closed envelope to:-

THE SECRETARY, MINISTRY OF SUPPLY, LONDON, W.C.2

Letter postage need not be prepaid, other postage will be refunded. All persons are hereby warned that the unauthorised retention or destruction of this document is an offence against the Official Secrets Act

UNCLASSIFIED

U.D.C. No. 537.22 : 771.531.342

Technical Note No. FH.479

October, 1953

ROYAL AIRCRAFT ESTABLISHMENT, FARNBOROUGH

Experimental work on the electrostatic
charges formed on aircraft camera film

by

J.A. Wells, A.F.R.Ae.S.

R.A.E. Ref:- IAF/Air.Ph/943/JAW

SUMMARY

The note gives a survey of the existing information on frictional electricity with particular reference to its application to "static" on aircraft camera film. Suitable equipment for the measurement of frictional charges is described. Some limited experimental work on the distribution of charge which occurs when a dielectric rubs continuously over a fixed surface and a method of assessing films for liability to static discharge are described. Recommendations are made for methods of reducing the occurrence of discharges.

LIST OF CONTENTS

	<u>Page</u>
1 Introduction	3
2 General information on frictional electricity	3
3 Detection of static charges	9
4 Simulation in the laboratory of the conditions for static discharges in a camera	11
5 Static inhibiting agents and increased conductivity of the film base	11
6 Testing of film samples and distribution of charge during winding	14
7 Conditions leading to spark discharge	21
8 Test of manufacturers' "anti-static" film samples	24
9 Applications to cameras and film	27
10 Future investigation	29
11 Conclusions	30
References	32
Advance distribution	33
Detachable abstract cards	-

LIST OF TABLES

	<u>Table</u>
Relative potentials	I
Electrostatic properties of "anti-static" film samples (back)	II
Electrostatic properties of "anti-static" film samples (emulsion)	III
General assessment of "anti-static" film samples	IV

LIST OF ILLUSTRATIONS

	<u>Figure</u>
Diagram showing arrangement of film and camera parts in F.49 camera	1
Examples of "static" marks on film from F.49 camera	2
Effect of air pressure on frictional-electric potential	3
Apparatus for detection and measurement of static charge and potential	4
Apparatus for testing static properties of film samples	5
Records of surface potentials on film due to static charges	6
Variation of potential or charge with insulation to earth of friction surface	7
Variation of potential or charge density on plate rubbing surface with change of plate insulation to earth	8
Relative surface potentials of "anti-static" film samples during unspooling	9

1 Introduction

The problem of static electricity in aircraft cameras has been described in an earlier R.A.E. Report¹. To illustrate the nature of the problem some examples of "Static" on aircraft camera film are shown in Fig.2(a), (b), (c) and (d).

Further part-time investigation of the subject has been undertaken by I.A.P. and Electrical Engineering Departments, R.A.E. and, more recently, at the University of Reading under a Ministry of Supply Research Contract. In addition the film manufacturers, Ilford and Kodak, have been asked to co-operate.

The work in Electrical Engineering Department has been primarily in measuring the surface conductivity of various samples of film and in investigating the possibility of increasing the surface conductivity. The results of their investigation will be reported elsewhere⁵.

At Reading some preliminary work has been done in attempting to reduce the tendency of the F.49 survey camera to produce "static".

The work described in this note is largely of a general nature intended primarily to assess the relative advantages to be gained by increasing the film conductivity as compared with modification to camera design. Some detailed work has been done in studying the distribution of charge on film which rubs over a plate, similar to the camera pressure plate, and also in deriving a method of assessing the effectiveness of "anti-static" film samples supplied by the manufacturers. In other respects the work has, of necessity, been rather limited in its scope. No investigation has been made of possible electrostatic induction effects in a camera or of the actual conditions under which a spark discharge occurs.

A survey of existing literature on frictional electricity is included and a rather detailed account of the experimental work is given to avoid unnecessary repetition by others in future investigations.

2 General information on frictional electricity

The fact that electric surface charges are produced when solids slide over one another, or when their surfaces are separated, is common knowledge and the laws relating to these "static" charges are given in most text-books on elementary electricity. If the area of the rubbed surface is A , of which only a fraction n has molecules actually in contact, (since the surface is rough compared with molecular dimensions) the true contact area will be $n.A$. The charge produced, $Q = C.v = (nA/4\pi.d)v$, where C = capacity of the opposed surfaces, v = the electrical potential set up by electron exchange due to contact and rubbing and d = the distance between the surfaces (distance between atoms). When the surfaces are separated the capacity falls to c and the potential difference rises to V so that $(nA/4\pi.d)v = cV$.

The fraction n is indeterminate, but would depend on the materials making contact and their surface finish. There is no law by which v can be calculated, neither can it be calculated from a known value of V (measured experimentally) since n is unknown. Most text-books assign a polarity to the charges developed by friction of different materials, but we shall show that this polarity depends largely on the presence of various surface films.

There is considerable information available on the effect of different surface conditions on the magnitude and polarity of frictional charges. The following summary, together with a brief description of some minor confirmatory experiments, provides evidence that the film base material cannot be considered as a standard commodity as regards its frictional electricity properties, at any time during its life. In the experiments described, no preparation of the film surfaces to make them "clean" was attempted. Sometimes the film was new from a sealed tin and in others it was not. In either case the initial surface conditions can be considered unknown.

2.1 Area of contacting surface

From the foregoing simple theory it can be seen that the charge produced will increase with increased contact area; this has been confirmed experimentally by Richards⁵. The fact is indeed fairly obvious since the charge produced by the larger area is simply the sum of the charges produced by a number of smaller areas. In experimenting with camera film, however, one must specify that the film is very dry (a good insulator) and that the surface conditions are such that the same polarity of charge is produced over the whole surface, for a given sample of film may produce opposite signs of charge, side by side, after friction with the same rubbing material.

In any given camera, the area of molecular contact at the various rubbing points will depend on the camera design and materials, particularly the material used for the pressure plate. There is, however, a further factor which is likely to cause additional surface rubbing on the pressure plate. The film always curls, along its length, with the emulsion inside the curve because of differential expansion of the emulsion and the film base. This effect varies with temperature and humidity. The tension of the film between the two rollers is insufficient to pull the film flat, and consequently the film will rub on the pressure plate as it is wound over by the camera motor by an amount depending on the clearance when the pressure plate is lifted. In a given case, humidity and temperature changes will vary the area of contact and thus the direct effect of temperature and humidity changes on the charge produced will be modified. Fig.1(b), (c) and (d) illustrates this point.

The majority of films marked by "static" are affected in the central portion only (see Fig.2(a)), the edges of the film being seldom marked; from the foregoing considerations, one would suppose that this was the result of the curling of the film (see also Section 6).

2.2 Materials in contact

Different materials in rubbing contact with any one other material produce different charges for the same amount of rubbing. Shaw^{9,10,11} has attempted to arrange the elements in a tribo-electric series according to the charges they develop when rubbed by silica. He does not claim that the differences in the charges measured are entirely due to the different molecular structure of the materials since apart from other factors, the results are influenced by different values of the fraction of molecular contact in a given area of mechanical contact. The effect of different materials is thus associated with a difference in the area of molecular contact in addition to the difference in the electron separation resulting from a difference in molecular structure.

The only work dealing specifically with the static charges produced by camera film is that of Rose⁸. He found that a brass rubber produced more charge on the film than a felt rubber. However, it will be shown later that the charge produced on the insulated surface from which the

measurement is made, is influenced by the degree of insulation of the rubber to earth, i.e. different charges on the film will be obtained with earthed and insulated rubbers. In the case of the apparatus used by Rose the brass rubber was definitely earthed while the insulation to earth of the felt pad would have varied with the environmental conditions and would not under any conditions have been earthed in the same sense as the brass rubber.

The present author has not attempted to determine the difference in charge obtained from different materials but has found that cork appeared to generate charge more readily than the other non-metals used with a film testing device described later. In confirmation of Rose's experiments, metals when insulated and rubbed by moving film, were also found to collect large charges.

The pressure plate of the F.49 survey camera is faced with cork (see Fig.1); this would not appear to be a very happy choice of material insofar as static charges are concerned although no doubt it is satisfactory for getting good surface contact between film and register glass.

2.3 Surface films

One of the major factors influencing the magnitude and sign of the charges produced by friction is the presence or otherwise of surface films, such as:-

- (i) adsorbed-gas and moisture films
- (ii) acid and alkaline chemical films
- (iii) metallic films and streaks

The effects of any one, or any combination, of these may be influenced in a complex manner by changes in the ambient temperature and pressure.

Adsorbed-gas and moisture films

Debeau¹² has investigated the variation of the frictional charge with pressure (Fig.3(a)). He shows that the curve can be matched with the adsorption isotherm and he deduces that the change of potential is due to the gradual removal of adsorbed layers of gas. Some data obtained by Rose⁸ for the back of Kodak air camera film rubbed by felt is shown in Fig.3(b). Over the pressure range 80 cm to 20 cm the variation of charge with pressure in general agrees with Debeau's results; the actual potentials shown, though similar, cannot be compared since they depend on the capacity of the test apparatus and the materials used. It will be shown later that the surface potential of free film after friction with other materials under similar conditions is more than 50 times the values shown, i.e. it is 6 to 7 Kv.

In the experiments by Rose (Fig.3(b)) the pressure after being reduced to 20 cm was increased again. The effect of this was that the charge instead of following the reduction curve increased to a much higher value. If the pressure was again reduced the charge fell off in a similar way to that obtained in the initial run but for a further increase in pressure increased more rapidly. Fig.3(b) shows the results obtained at two different temperatures. When the pressure was finally increased to 76 cm the charge obtained was considerably higher than at the start of the test. At the lower temperature the charge was almost double the original value, when the pressure was about 60 cm.

In some further experiments however in which the felt was replaced by a polished brass rubber the charge fell as the pressure was reduced, as it did with felt, but when the pressure was restored the charge declined sharply, i.e. the effect obtained with the felt was reversed.

These results are probably related to the removal of adsorbed gas layers when the pressure is reduced. The original charges are not obtained when the pressure is restored because the original gas layers are not restored immediately, the material taking some time to regain its original condition. Alternatively, the results may have been influenced by the removal of moisture from the film at the lower pressures.

From the practical aspect of the effect on aircraft camera film, the exact mechanism is not important, the point of interest being that with dry film the charge changes with air pressure. Two deductions may be made:-

- (i) The fall of potential with pressure may sometimes have the effect of restricting spark discharges to a definite altitude layer. In the pressure range shown, 760 mm to 100 mm, (roughly ground level to 50,000 ft) the relationship between potential difference required to produce a spark in air and air pressure is linear. The actual voltage required to spark is largely influenced by the shape, relative sizes and polarities of the two charged surfaces. In the case of two parallel plates 3 mm apart, 23,000 volts is required to start a spark at 760 mm pressure and 750 volts at 100 mm pressure. At lower pressures the relationship is non-linear and the minimum sparking voltage under any condition is about 300 volts. If we disregard the scale of volts in Fig.3(a) and assume that the curve is characteristic of pressure frictional-potential relationships and that the dotted curve A B shows the sparking voltage relationship with pressure, then spark discharges from the film would be more frequent in the altitude layer 36,000 to 55,000 ft.
- (ii) From the results of Rose (Fig.3(b)) it would appear that increased production of static charge can take place if a fall of pressure is followed by a rise in pressure. In its application to air photography this means that "static" is likely to occur when a photographic run is made immediately after the aircraft has reduced height for some reason, such as after climbing over mountainous regions on the outward flight.

Shaw⁹ found that layers of moisture could affect the charges produced in a way which varied with the amount the surface was rubbed. For example, he found that if zinc is rubbed on clean dry glass the zinc at first takes up a positive potential, which with continued rubbing falls to zero and finally becomes negative. If, however, the glass is blown with water-saturated air the charge on the zinc is negative at the start and with continued rubbing this negative charge is increased and reaches a higher value than either the positive or negative peaks obtained with the clean dry glass. In his experiments with aircraft camera film Rose⁸ found that in a humid atmosphere the charges on the film were greater than in a dry atmosphere, when rubbed either with felt or brass.

It would appear that moisture films will affect the charges produced appreciably with a tendency to increase them. In aircraft the normal tendency of the reduced pressure at high altitude would be to remove moisture films and therefore reduce charging. However it may have quite

the reverse effect if the surface exposed by removal of the moisture film is capable of producing more charge than the moisture film. Another factor to be considered in removing moisture films is that the insulation of the material will be increased and consequently charges will not leak away. The film used by Rose in his experiments was mounted on an insulating stand so that there was no leakage of charge.

In practice there will probably be an optimum value of humidity for any particular roll of film at which most charge will be produced by a given type of friction. It is probable also that the intensity of any discharges which do take place will be influenced by non-uniformity in the moisture content of the surface. Patches of film with a relatively high moisture content may be insulated by the surrounding film which is relatively dry. Again, the edges and the outside layers of a roll will lose moisture more quickly than the inner portion of the roll so that in some cases film with a high capacity for generating charge, but having poor insulating properties may be effectively insulated from earth by the dry film surrounding it.

Acid and alkaline chemical films

Shaw⁹ has shown that the value of the charge and its polarity can be affected by the presence of chemical films. This has been confirmed by experiments with the film-testing rig shown in Fig.4 and by experiments on a camera register glass. According to Shaw the acid effect is positive and the alkaline effect negative; this assumes however that the surface is thoroughly clean before treatment. In the present experiments no attempt was made to clean the surface since the object was merely to see whether the addition of an acid or an alkali would have any marked effect on the existing production of charge.

The cork rubbing pad of the apparatus in Fig.5 was treated with solutions of citric acid and sodium phosphate, alternately, to give it either an acid or an alkaline reaction. The effect of the alkaline wash was to raise slightly the negative potential to which the rubber became charged as the film was wound over from the spool. The effect of the acid wash was to make the sign of the charge completely random; the potential measured at the friction plate being very similar to that produced by the sample of developed film shown in Fig.6(j). These results could be repeated by using alternate acid and alkaline washes. The cork was thoroughly dried after each application.

Some further experiments were made rubbing a piece of glass with cork, perspex and pieces of camera film. The glass was washed in hot water and tested clean, with an acid wash and with an alkaline wash. In some cases the different treatments failed to produce any change in the polarity of the charge. When using cork and film emulsion as rubbers both alkaline and acid washes changed the normal negative polarity of the charge to positive. The production of negative charge on the "clean" glass surface was consistent and the results confirm that the polarity of charges produced is affected by the presence of chemical films.

Organic films

Shaw has reported that organic films can affect the charges produced¹⁰. These films or streaks are left on the surface of the materials concerned after they have rubbed organic materials.

Metallic films

If the camera film rubs over metal, a metallic streak will be deposited as reported by Shaw¹¹ in experiments with silica. Shaw notes that the contact potentials formed on a material by rubbing or surface separation with a metal are higher than with non-metals. This is confirmed by Rose⁸ who found that the charges were much higher with a brass rubber than with a felt rubber.

Camera film, therefore, which carries molecular metallic streaks would be more likely to produce discharges than clean film. The effective capacity available for the discharge would also be increased since the metallic streaks will, if sparking potential has been reached, discharge completely when brought near an earthed conductor (large mass at lower potential).

Surface strains

At an early stage it was noted that if the film back were rubbed with the back of another piece of the same sample of film the two pieces of film became oppositely charged. Which piece became positive and which negative appeared to be quite fortuitous. Shaw¹⁰ gives experimental evidence to show that the frictional electrical properties of a body are changed by surface strain and that the production of charges after friction between like solids is most likely caused by differential strain of the two surfaces.

When two solid bodies are rubbed together their surfaces become progressively strained to a limiting value. The surface temperatures rise with friction and surface strain is limited when the relaxation temperature of the solid is reached, the original surface electrical characteristics of the bodies then being restored. If the surfaces are in a state of strain after rubbing, the strain can be removed, and the original electrical properties restored, by deliberately heating the bodies to the relaxation temperature.

In rubbing two surfaces together it is seldom that the friction areas on the two are similar, consequently, unless the relaxation temperature has been reached on both surfaces, they will be in different states of strain. If the material of the two surfaces is the same, say cellulose acetate, then one surface will produce a positive charge and the other a negative charge. It can be demonstrated that if the method of rubbing is reversed, i.e. if the surface which had the larger rubbed area is arranged to have the lesser rubbed area, then the polarity is reversed. The piece of acetate which formerly produced a negative charge now produces a positive charge, and vice versa.

The nature of the charges produced by rubbing between dissimilar materials may also be changed because of differential surface strain.

In taking some records of the surface potential of camera film (see Fig. 6(a) and (b)) it was found that, with the particular roll of film being used in the test, there was a definite positive charging of the film surface which could be repeated fairly closely for consecutive runs over an earthed friction plate. If the friction plate were insulated the plate took up a correspondingly steady negative charge (Fig. 6(f)). When rubbing with a piece of the same film by hand however the plate took up a positive charge. It was determined that the sign of the charge produced was determined solely by the rubbing pressure. If the pressure was light the friction plate became negatively charged but with a slightly heavier pressure it became positively charged. This effect may be the result of surface strains or possibly it may be due to an organic film from the cork rubber.

Electret effect

Charges introduced by friction on some pieces of film are extremely persistent and difficult to remove. If a piece of dry glass is held by an insulated holder and then charged by friction with some other material the charge may persist for some time, but a single slow wipe with the moist palm of the hand will remove it completely. If some pieces of film, however, are charged in a similar manner, no amount of wiping or flat contact with the hand will remove the charge although in most cases it is reduced in varying degrees, and will disappear with time.

It is possible that there is an "electret" effect in the case of these film samples. The electret is described as a frozen charge which occurs within a dielectric when it is heated in a strong electric field. If the dielectric is then maintained at a low temperature the charge may persist for weeks. A description of the electret effect is given by Adams^{1,2} and others.

Shaw¹¹ has stated that the surface temperatures due to friction may exceed the relaxation temperature of the particular solid. It is possible, therefore that in some cases friction can produce both the electric field and the high temperature necessary to leave the film with a charge just below the surface, where it will be more persistent than the normal surface charge. The possibility of such an effect could be confirmed only by careful experiment using methods of discharging the film, such as ionisation or radioactive substances, which would not introduce a new charge to the film and would be effective against surface charges only.

In an experiment with the F.49 survey camera, an electrometer probe (see Section 3) was inserted through a hole drilled in the magazine casting adjacent to the take-up spool so that it would give a reading if there was any charge on film passing from the measuring roller to the take-up spool. A 20 ft length of exposed film was operated through the camera in six separate tests. On each occasion the indications of the electrometer were almost the same. Sometimes a positive indication and sometimes a negative indication was given during each run. There was no significant accumulation of charge on the film on the spool at the end of the runs.

The film was removed from the camera and rolled out flat on the bench and examined for evidence of residual charge. Appreciable charges were found to exist on the film back. The position and sequence of the charged areas of film were found to correspond with the record taken when the film was passed through the camera. The experiment demonstrates that with this particular sample of film the charges were persistent. No charge could be detected on the emulsion, which was also sufficiently conductive to shield the charges on the back from the electrometer probe.

3 Detection of static charges

In the first place a search was made for a convenient method of detecting the presence of charges of static electricity, on film or on parts of the camera, and of measuring the relative electrical potentials. The methods available at the time were not adaptable for measurements inside the camera magazine.

Of the methods considered, the use of an electrometer valve appeared to be the most suitable. An instrument was constructed which was similar in some respects to that described by Bulgin² for detecting static charges on rubber-tired vehicles at the Dunlop Rubber Co.

A diagram of the circuit for the electrometer valve as used in the present investigation is shown in Fig.4. This was designed for measurement of potential and current in conjunction with a D.C. amplifier. The output from the amplifier can be used for operating a recorder for potential measurements, or an integrator motor for measurement of leak of charge to earth, when the input circuit is connected for current measurement.

Referring to Fig.4, the grid of the Osram E7J electrometer valve is connected to a small circular plate carried in a polythene bush in a metal screening tube. In this particular design the screening tube also carries the electrometer valve. When the contact C is made with the grid wire the electrometer valve has a standing bias of -4 volts. When C is broken, the grid retains this potential and static charges may be detected by induction on the small metal "grid plate". The end of the screening tube is closed except for a small central hole, of lesser diameter than the plate and chosen to suit the charges being measured and the distance d from the charged surface. The whole of the grid circuit is fully screened, the components in the hand-held detector tube being connected to the batteries and to the anode milliammeter by screened cable. To detect a charge or to measure a surface potential the aperture in the screen is covered with a conducting plate, to give zero-field conditions, and the contact C is made and then broken. On uncovering the aperture and bringing the device near a charged body, the potential of the grid will be changed by induction and for a given distance away the change in anode current is a measure of the potential to earth of the charged surface being examined. The instrument was calibrated in conjunction with an EHT unit and an electrostatic voltmeter.

It should be noted that the instrument does not measure true surface potentials since the presence of the detector tube will distort the field. For the present investigation however only relative values were required.

The grid resistance of the valve is of the order of 10^{11} to 10^{15} ohm and there is no appreciable leak for two or three minutes, which gives adequate time for making measurements. For measuring leakage of charge the grid is connected to the charged body through a high resistance (about 50 M Ω) and the contact C is permanently made. Under these conditions, the quantity of charge leaking to earth can be measured by connecting a small integrating meter to the output from the D.C. amplifier (see Fig.4). With the contact C made and then broken a record of the potential changes is obtained by connecting a recording meter to the D.C. amplifier. The permissible change in the grid bias of the electrometer valve is from -2 to -6 volts, the output of valve and D.C. amplifier being linear over this range. A narrow insulated probe was constructed for detecting charges in more inaccessible parts of the camera, but to keep grid leakage to an absolute minimum most of the measurements were made with the design described here.

In constructing this apparatus it is important not to handle the glass envelope of the valve and to mask the valve from light to avoid photoelectric effects. This latter condition was satisfied in the design of the screening tube by an "overlap" construction as indicated in Fig.4 and by finishing the surfaces near the "exposure" end of the tube with a matt black paint. The polythene bush, of course, was not an effective light mask.

This instrument was used in conjunction with the film-testing rig shown in Fig.5 to measure potential changes and leakage charges. As a simple electrometer, i.e. with anode current indicator, it was also used in the general examination of films for their electrostatic properties.

4 Simulation in the laboratory of the conditions for static discharges in a camera

With the object of providing a method of testing whether static discharges in the camera were affected by changes in camera construction or film base material, some attempts were made to simulate the conditions under which the film was marked by discharges. It was known¹ that, if film were thoroughly dried in high vacuum and then roughly handled, discharges would occur and after development the negatives of some of the samples would be marked. This treatment seemed too drastic as a test practice for films since improvements in film material, while they might prevent static under the worst treatment experienced in a camera, might fail under such severe conditions. It was decided to limit the conditions to what was judged to be the worst aircraft conditions for static. A brief description of the test follows although it was unsuccessful. From the four attempts made, two with an F.49 survey camera which had produced bad "static" in the air, and two with the F.24 camera, only two or three faint marks were obtained with the F.49 and none at all with the F.24. Details are given in the Table on Page 12.

In the tests on the F.24 camera the humidity was raised during the run to test whether dry film on the roll operating into a more humid atmosphere would produce static marks more easily. The drying to which the film was subjected was certainly equal to the worst conditions likely to obtain in service and the conditions must have been similar, at one stage during the run, to those prevailing in an aircraft.

At a later stage in the investigation it was found that samples of "standard" film varied considerably in their electrostatic properties and the particular roll of film used in any given conditions must have a large influence on the static charges produced. In reviewing the various surface conditions affecting the charge produced (Section 2) it is evident that they could not be controlled during manufacture. Failure to produce marks on the film under a simulation of aircraft conditions is attributed largely to the fact that the rolls of film used for the tests could not be preselected for their electro-static properties.

5 Static-inhibiting agents and increased conductivity of the film base

It is evident that were the film conducting on both sides little trouble would be experienced from static discharges. Conducting is used in a relative sense and it is considered that at humidities down to 40% the emulsion side of standard film is sufficiently conducting. The rate of leakage of charge must be sufficient in relation to the surface capacity to prevent the potential reaching a sparking value. The back of the film is the surface most likely to give trouble and fortunately this surface should be simple to treat in some manner. Treating of the emulsion side of the film might possibly prove a more difficult problem. The inclusion of salts in a gelatine sub-layer had been mentioned to the film manufacturers during discussions at R.A.E. but such a process was not approved because of the possibility of the gelatine becoming sticky from moisture excess. It appears that the difficulties in using a salt may be overcome since British Patent Specification No. 636327⁵, describes a method of applying the salt of a bi-guanide compound in various arrangements, either on the emulsion side or the back of the film. The way in which this salt reduces static electricity is not disclosed, i.e. whether the effect is purely to increase the conductivity of the film or to reduce the contact potentials^{5,6} when the film is rolled or is pressed into contact with various parts of a camera, with or without mechanical sliding between the surfaces.

Camera	Film	Preparatory treatment of film	Exposure interval	Conditions during test run	Static markings
F.45	Safety base	Complete camera and film in test chamber for 12 hours at 30°C, 50,000 ft with tray of calcium chloride.	10 secs	After an initial soaking period of 1 hour at -20°C and 15,000 ft altitude the complete roll (165') was operated through the camera continuously under the same ambient conditions.	3 faint static marks halfway through roll.
F.45	Safety base	As above.	10 secs	As above but only half roll used (80').	One fairly distinct mark at end of roll.
F.24	Nitrate base	Complete camera and film in test chamber for 22 hours at 30°C, 20,000 ft and 30% R.H. (silica gel in chamber).	2 secs	Temperature reduced to 7°C and maintained for ½ hour. Reduction of pressure commenced and camera started, 15,000 ft maintained after 3 minutes. Camera stopped after 8 minutes 47' of film. Temperature between 7 and 8°C throughout run. At the start of the run hot water was introduced into the chamber, without removing the silica gel and the R.H. increased from 18 to 30%.	None
F.24	Nitrate base	Complete camera and film in test chamber for 22 hours at 30°C, 20,000 ft and 30% R.H. (silica gel in chamber). <u>Note:</u> -- The silica gel was removed from the chamber at the start of the run.	12 secs	Temperature reduced to 5°C and held for ¼ hour. Camera started and pressure reduction started. 20,000 ft reached in 2 minutes. Hot water introduced into chamber after 4 minutes. R.H. reached 30% after ¼ hour and 90% after 20 minutes when camera was stopped. Pressure was increased to 15,000 ft from 20,000 ft after 17 minutes. Temperature was between 6 and 8°C throughout run.	None

British Patent No. 678329 describes how an alkali metal or ammonium salt of a condensation product of formaldehyde and naphthalene sulphonic acid is included in the silver salt emulsion layer to make it anti-static¹⁴. Since this process seems to leave the back untreated it is difficult to see how real improvement can be expected.

The static electricity nuisance is general in industries such as paper mills, rubber, nylon and plastic manufacture and there are many anti-static agents on the market and under development^{2,6,7}. It is evident from the literature available that the problem is difficult to solve purely by modifying the design of machinery which handles the dielectrics concerned.

The Air Survey Co. Ltd., state that they have derived some benefit in reducing static by treating the register glass and other parts of their survey cameras with a perspex polish marketed by I.C.I. and O'Cedar. Messrs O'Cedar have stated that the polish comprises an emulsion of fats and waxes with the addition of an alkaline wetting agent; they also supply an "Anti-Static Polish No. 32" which contains a lower proportion of wax and is easier to apply than the perspex polish.

In tests at R.A.E. the perspex polish reduced static charges in some cases but not in others, although conditions as regards temperature and relative humidity were the same. Polish No. 32, however, has been found to eliminate all appreciable charge at R.H. values above 40% and to have some effect at values as low as 10%. The action of these polishes in reducing charges is twofold. In the presence of moisture in the air an electrolytic film is formed evenly over the surfaces by the action of the wetting agent. With such a continuous conducting film any charges formed would leak to earth. Additionally, depending on the nature of the wetting agent, the film may be static inhibiting by reducing the contact potentials in relation to other materials. The effectiveness of static inhibitors is determined by the quantity of the inhibitor added to the surface up to an amount where the formation of charge is negligible. With some inhibitors the charge developed is cyclical and seems to depend on the provision of successive molecular layers on the surface of the dielectric so that increasing layers may result in a change of the sign of the charges developed (see Section 2). Inhibitors with a high dielectric constant are the most effective when only thin layers are attainable. Distilled water is good in this respect⁶.

Random results given by the perspex polish can possibly be explained from the foregoing data, i.e. the difficulty in retaining the correct amount of inhibitor in the final polished layer of the film surface and the possibility that the inhibiting action of the aqueous solution formed on the film is of the type where the charges developed vary in a cyclic manner depending on the molecular thicknesses of the layer.

Tests showed that the formation of static was reduced by both the polishes but the action was found to be primarily one of increased conductance depending on the hygroscopic action of the wetting agent in spreading a conducting layer over the film surface. Polish No. 32 was more effective in this respect.

It was considered unlikely that the polishes would have any lasting effect when applied to camera parts; laboratory tests with the F.95 camera confirmed this.

Some bad static was experienced during survey photography in Cyprus but application of the polish to the register glass of the F.49 camera failed to improve matters, bad static marks being present on developed film from cameras to which the polish had been applied.

While it seemed improbable that the polish could be used to provide a surface layer on the film back in manufacture, it was decided to treat a length of unexposed film to see if processing was affected and to test it for development of static charge as a means of deciding whether increased conductivity of the back of the film alone was sufficient to prevent appreciable charges forming. The F.95 camera was used for this test, loaded with an 80' roll of film, 40' of which was treated with the polish and the other 40' untreated. Room conditions were N.T.P. with a relative humidity between 50 and 60%. The complete roll of film was run through the camera and on processing no static marks were present on either treated or untreated lengths of films. In view of previous unsuccessful tests to produce static in the laboratory this result was not unexpected. The polish was found not to affect the processing.

Next a roll of exposed film was treated in a similar manner and the camera was operated in a dark room to detect visible static discharges. After the eyes had become dark adapted, occasional discharges could be seen when the untreated portion was passing but there was no evidence of charge when the treated portion was passing through the camera. This result was maintained irrespective of which half of the film was first passed to the take-up spool.

The foregoing operation of the film through the camera was repeated while measurements were made for accumulation of charge on the take-up spool. If the treated portion were passed through first there was no indication of charge until the untreated portion was reached, when there was a progressive accumulation of charge on the spooled film. In the case of operation in the opposite sense considerable charge was accumulated at first but this ceased when the treated portion of film was reached. It was also noted that there were considerable changes in potential from untreated film passing through the camera but none from the treated length.

6 Testing of film samples and distribution of charge during winding

In view of the information which was available at this stage (Section 2) and the unsuccessful attempts to produce static marks from a camera operated under laboratory conditions (Section 4) it seemed improbable that results could be obtained and reproduced with certainty under conditions similar to those experienced in an aircraft. In testing whether modifications to a camera had reduced the tendency to produce static the difficulty would be to ensure that the roll of film used in the test had similar static properties on each occasion. Even were it practicable, any pre-examination of the film in a dark room would not be permissible since handling of the film is likely to change its properties and these changes would not be within the control of the operator.

Some samples of film, for which anti-static properties had been claimed, had been received from the film manufacturers, and it was necessary to devise some relatively reliable method of assessing these samples. The rig shown in Fig.5 was constructed for this purpose. Two $\frac{5}{8}$ -inch camera spools are mounted on polythene insulating bushes attached to a standard film-winding rig with the axes about 15 inches apart. A cork-faced metal plate mounted on insulating supports is placed mid-way between the two spools so that when winding the film from one spool to the other the film rubs on the cork. Facilities are provided for connecting all or any combination of spools or friction plate to earth as required.

In a preliminary investigation of numerous samples of film with this rig it was determined that some film induced charges largely of one polarity, while other film gave charges of both polarities in a completely

random manner. Using film which gave consistent polarity of charge it was determined that the distribution and polarity were as indicated in Fig.5(a) and (b), that is:-

- (a) film which made rubbing contact with an earthed surface carried away a positive charge, while the film approaching the rubbing surface carried only slight negative charge, and
- (b) film which made rubbing contact with an insulated surface carried no charge away, while the film approaching the insulated surface was negatively charged.

It was further noted that if the take-up spool were insulated from earth, it became positively charged when the rubbing surface was earthed but was uncharged when the surface was insulated. Also, the feed spool when insulated, showed a small fluctuating charge when the rubbing surface was earthed but when the rubbing surface was insulated a steady positive charge would accumulate on some occasions while on others a negative charge would build up and fluctuate in value, sometimes with a reversal to positive polarity.

A number of records of the potential measurements made on the film and the friction surface (cork) are shown in Figs.6(a) to 6(l). These were made with the apparatus shown in Fig.4, i.e. electrometer, amplifier and recording voltmeter. The position of the electrometer during these measurements was as indicated by P_1 , P_2 and P_3 , as appropriate, in Fig.5. Rubbing was on the back of the film as it passed over the cork-faced plate. The film was wound over by hand at a speed of about 1 ft/sec but it was found that variations in film speed of $\pm 10\%$ had no appreciable effect on the results. A comparison of Fig.6(a) and (b) shows that a 10% change in film speed has had little effect on the potential and that the results are reasonably consistent.

The film samples used in these experiments were as follows:-

- (A) Figs.6(a) to (j) $2\frac{1}{4}$ inch nitrate base film, exposed but not processed. Stored out of tin in laboratory for approximately 6 months.
- (B) Figs.6(l) and (k) $5\frac{1}{2}$ inch nitrate base film, exposed and processed. This was a new film sample which had been used for laboratory tests in the cold chamber and afterwards stored in a tin.

The relative humidity during all the tests did not vary much from 55% and the temperature was between 13°C and 20°C , as noted on the illustrations. In examining these results it may be assumed that when the spools are insulated the conditions are similar to those obtaining when the edges and outer coils of a roll of film have become very dry, thus effectively insulating the remainder of the roll from earth. In addition to the records in Fig.6 which include the peak voltages, a large number of readings of average potential were taken with the small integrating meter previously mentioned.

The relative potentials, or charge density, of the plate and the film surface for various earthing conditions of the plate and the spools are shown in Table I. The unbracketed figures in this table apply to film sample (A), i.e. exposed, unprocessed nitrate base film. They are average values from a number of tests with the integrating meter and the recording voltmeter. The figures in brackets apply to a sample of

exposed, unprocessed acetate base film each value being the average of three readings of the integrating meter. In each case a value of 100 is assigned to the film surface potential after it has rubbed over an earthed plate.

In some further experiments, the results of which are shown by the curves in Fig.7, the potential of the plate and the leakage charge from the take-up spool were measured for various values of insulation resistance of the plate to earth. The curves marked E are for friction on the emulsion and those marked B are for friction on the back.

Detailed explanation of the results is complicated by the fact that electron separation does not occur at the plate only but also at the feed spool as the film is unwound (see Fig.9). Some further experimental work would be necessary in confirmation of any theory advanced as to the mechanism of energy dissipation. However, the following general explanation of the results is suggested.

By experiment (see Fig.6(f)) the plate, when insulated, reaches a mean steady potential after a few feet of film have passed and the potential of film leaving the plate is then a minimum (see Fig.6(d) and (e)). With some samples of film the potential of the surfaces leaving the insulated plate is, within the limits of measurement, zero, as shown in Fig.6(d) while with other samples it is small but measurable. When both film spools are earthed the potential obtained on the plate is a maximum (see Fig.6(j)) and is reached after a few feet of film have passed; it does not build up progressively during the winding period.

The limitation of charge density, or potential, of the plate when it is insulated could be explained by leakage from the plate supports and along the film surfaces and possibly, also, gaseous discharge. The limitation of surface density on the film leaving the earthed plate could be explained also as being a result of leakage. However, the absence of charge on the film leaving the insulated plate cannot be attributed to leakage. In fact, when the plate is insulated the presence of positive charge on the film is dependent on leakage of negative charge from the plate or, alternatively, a progressive increase of negative charge on the plate.

It is considered therefore that for any given frictional conditions there is a threshold charge density of the plate which gives a field strength of sufficient magnitude to balance the contact potentials and thus eliminate electron separation from the film, i.e. the negative charge on the plate repels electrons (negative charges) and when the force of repulsion equals the force causing separation of electrons a state of equilibrium exists. Depending on the film sample, the combined result of surface leakage over the film to earth via the take-up spool and separation of charge at the take-up spool may be sufficient to prevent the potential of the plate from reaching the true limiting value, and in this case some positive charge will be carried away on the film surface to the take-up spool.

With the plate earthed, all electrons leak to earth and a maximum positive charge is carried away on the film; correspondingly the surface potentials of film leaving the plate are a maximum. Again, the separation of electrons from the film surface is limited to a threshold value where the field strength balances the contact potentials, i.e. the positively charged film attracts electrons and a point is reached when this force of attraction is equal to the forces causing separation. No samples of film were tested in which the plate became positively charged and the film negatively charged but in such a case the explanation of the results would be similar.

An effect which would appear to be related to the foregoing has been reported by Gill and Alfrey⁴. In their experiments small blocks of a dielectric were allowed to slide down an inclined metal plate into an insulated metal container. The metal plate was earthed and the charge collected by the metal container from the blocks was measured by an electrometer. A second metal plate was placed above and parallel to the earthed plate and connected to one pole of a D.C. supply, the other pole of which was earthed. Depending on the polarity of the D.C. supply it was found that the charges carried away on the blocks could be either increased or decreased. When the polarity was such that the charge was decreased it was found that it could be reduced to zero by increasing the applied voltage after which any further increase in the applied voltage imparted a charge of opposite polarity to the blocks.

The negative charge on film approaching the plate (see Fig.6(g) and Table I(h)) is a maximum when the plate is insulated and the feed spool is earthed (see Table I(k)). Its presence can be explained as due to separation of the surfaces at the feed spool, where most of the positive charge on the emulsion would leak to earth via the spool allowing negative charge to pass away on the film, and surface leakage of charge from the plate. This negative charge is lower when the feed spool is insulated because the portion due to separation is then dissipated locally at the spool since the positive charges on the emulsion side of the film are unable to leak to earth.

Referring to Fig.7 the data shown are from four separate experiments and cannot, unfortunately, be related to one another. It should perhaps be mentioned again that each experiment takes time, and results are only found to be consistent over very short periods, irrespective of whether the ambient conditions are changed or not. The curves in Fig.7(b) are actually for leakage charge from the take-up spool but their general shape is representative of the change in surface density of charge on film leaving the plate with change in leakage resistance of the plate to earth. Curve B for the film back in Fig.7(b) is not typical and is doubtless due to rather low film surface resistance at the time of the experiment. As a rule the film charge density or potential, when the plate is earthed, has much the same value as the plate potential when the plate is insulated as can be seen by referring to Figs.6(a) and (f). The curves in Fig.7(b) were the only ones available, without further experimental work, to show that the general shape was similar to the curves in Fig.7(a).

It is proposed to develop a simple theory for conditions in which the film has relatively high insulation; this is likely to be the case when spark discharges occur.

The rate of charge separation during rubbing is opposed by the charge which accumulates on the rubbed surfaces. Since the mean distance between the surfaces during rubbing will be constant the rate of charge separation, b , will bear a linear relationship to the charge density or the surface potential, v , if no other significant factors are present. Thus when film rubs over a fixed insulating surface the potential of this surface will reach a limiting value, V , and the rate of charge separation, b , will then be zero. The relationship between v and b , for the assumed conditions, is shown graphically in Fig.8(a) where v_f is the surface potential of film covering the plate and v_p is the plate surface potential, the former being positive and the latter negative. The equations to these curves are:-

$$v_f = \frac{b}{B} \cdot V \quad (1)$$

and

$$v_p = \frac{b}{B} \cdot V - V \quad (2)$$

where B is the maximum rate of charge separation; i.e. the positive charge density on film leaving the plate is a maximum V when rubbing starts and falls to zero as the negative charge density on the plate reaches the maximum value V . It will be noted that the arithmetical sum of the charge densities is constant, i.e. the potential difference between the film and the plate remains constant.

When the plate has a leakage to earth of R ohms it is charged to a steady voltage V_p , the rate of charge separation, b , then being equal to $\frac{V_p}{R}$, the leakage current to earth. The surface potential of film leaving the plate is then $V_f = V - V_p$. Substituting $\frac{V_p}{R}$ for b in equation (1):-

$$V_f = \frac{V_p}{R} \cdot \frac{V}{B}$$

or

$$V_f = \frac{V - V_f}{R} \cdot \frac{V}{B}$$

from which

$$V_f = \frac{V^2}{RB + V} \quad (3)$$

From equation (2) the plate potential V_p at equilibrium is given by:-

$$\begin{aligned} V_p &= V_f - V \\ &= \frac{V^2}{RB + V} - V \end{aligned} \quad (4)$$

The curves to equations (3) and (4) are shown in Fig.8(b). For friction on the back of the film, experimental values from Fig.7 are:-

$$V_p = 3.7 \quad \text{when} \quad R = 1$$

$$V_p = 5.3 \quad \text{when} \quad R = 3$$

and substituting these values in equation (4) gives:-

$$V = 6.6 \quad \text{and} \quad B = 8.2$$

thus the equation to the experimental curve for the film back in Fig.7(b) is:-

$$V_p = \frac{43.5}{8.2R + 6.6} - 6.6$$

The curve to this equation is shown in Fig.8(c) together with the experimental points. When the leak to earth consists of the plate supports and the film surface via the spools the experimental value of V_p is 6.1 (Fig.7(a)), i.e. 93% of the theoretical maximum value $V = 6.6$. The curve in Fig.8(c) agrees with the experimental points as well as could be expected and values of V , the maximum voltage, and B , the maximum rate of charge separation, calculated from equation (4) should be reasonably accurate in the case of normally dry insulating film.

The foregoing theory could be used as a basis for assessing the static properties of film samples, i.e. values for V and B could be obtained from the simultaneous equations given by substituting two values of the plate resistance R , and the corresponding experimental values of v_p , in equation (4). Film samples giving high values of V and B would be the most likely to produce static marks on the emulsion.

The tests on the "anti-static" film samples described in Section 8 were made before the experimental work just described and a more approximate method of assessment was used. The method is sufficiently accurate for the purpose and there does not appear to be any justification for repeating the tests.

It will be noted that equations (3) and (4) are for an equilibrium condition and that capacity and inductance are not involved. It is important to note that the potential difference between the two friction surfaces, one of which (the film) is a good insulator, is not affected by the resistance to earth of the other surface. The effect of leakage at the plate is merely to change the relative potentials to earth. This is illustrated in the theoretical curves of Fig.8(b) which should be compared with the practical measurements of Figs.6(a) and (f). These latter illustrations show that the plate voltage to earth, when it is insulated, is similar to the film surface voltage when the plate is earthed.

The time-potential relationships, i.e. the transient conditions, are not required to assess the static properties of film samples which was the original object of the experiment (Fig.8). They may be important, however, in any consideration of the optimum conditions for spark discharges when friction is of short duration. In the present paper it is not convenient to give any detailed analysis but the general lines on which the equations for the transient conditions may be obtained will be given.

The fundamental voltage-time relationship may be obtained from equations (1) and (2). For example, in the case of dry film (highly insulating) which rubs over a plate with high surface insulation there will be no leakage currents and resistance, capacity and inductance are not involved. The surface potential is from equation (2):-

$$v_p = \frac{b}{B} \cdot V - V$$

$$b = \frac{dv_p}{dt} = \frac{v_p + V}{V/B}$$

or

$$\int \frac{dv_p}{(v_p + V)} = \int \frac{B}{V} \cdot dt$$

After putting in the conditions $v_p = 0$ when $t = 0$ the solution to this is known to be:-

$$v_p + V = Ve^{-\frac{Bt}{V}}$$

$$v_p = V \left(e^{-\frac{Bt}{V}} - 1 \right) \quad (5)$$

$$b = \frac{dv_p}{dt} = Be^{-\frac{Bt}{V}} \quad (6)$$

Similarly, the film surface potential at any time t is given by:-

$$v_f = Ve^{-\frac{Bt}{V}} \quad (7)$$

v_p is negative and v_f is positive, their arithmetic sum is equal to V at any instant and the potential difference between film and plate is therefore constant. It will be seen that the potential of the plate rises and the potential of the film surface decays according to an exponential law.

Equations (5) and (7) would approximate to practical conditions only when the conductivity of the rubbing surfaces was negligible. If either surface has appreciable conductivity then a resistance term R and a capacity term C must be included; the inductance L may also be significant. If L , C and R are applicable to the rubbed surface only, i.e. the plate, and are equivalent to a simple series arrangement then the voltage equation would be:-

$$Ri + L \cdot \frac{di}{dt} + \int \left(i \cdot \frac{dt}{C} \right) = \frac{V}{B} \cdot \frac{dv}{dt} - V \quad (8)$$

where i is the leakage current from the plate.

The conditions for which equation (8) is true could be set up in the laboratory but they would not apply to practical conditions where the equivalent resistance, inductance and capacity could be represented only by a series-parallel arrangement.

Also the treatment of resistance R will depend on whether it is due to surface or bulk conductivity of the rubbing materials. In practice it is likely that surface conductivities are predominant and this being so there will obviously be a charge-density, or potential, gradient over the rubbed surfaces. The potential will be a minimum at the earth points and a maximum at points remote from earth. If we consider this in relation to the film emulsion rubbing a dry register glass then the potentials will be higher in the central region, i.e. there would be a lateral potential gradient. This may explain why some of the marks known to have occurred on the emulsion side are predominantly in the centre of the film. This would not apply when one of the surfaces is relatively a good conductor for the potential gradient would be small. Thus in the case of friction

between the back of the film and the pressure plate, the cork facing of the latter has a relatively low bulk resistivity and marks would be expected to occur over the entire film surface. It has however been mentioned earlier that charges on the back of the film are still likely to be higher in the centre where most of the friction is likely to occur because of "bowing" of the film.

Attempts at a complete mathematical analysis of the transient frictional-electric effects obtaining with this particular type of friction would be complex. In a general treatment, terms of R , C and L would be assigned to both friction surfaces. Further confirmatory experimental work would be necessary, with improvements and additions to the measuring equipment at present available. In their practical application to the present investigation the transient effects are significant in relation to friction which is of short duration. In cases where the film rubs intermittently it is obvious that the possibility of a spark discharge from the film to an earthed part of the camera will be increased if the potential rises rapidly and is sustained.

The film potential is a maximum when friction commences but decays exponentially (equation (7)) when the rubbed surface is insulated. However if the rubbed surface is fully conducting to earth, the potential will be sustained while friction continues.

7 Conditions leading to spark discharge

The stages at which discharges can occur are:-

- (i) During manufacture of the film.
- (ii) During any re-spooling of the film.
- (iii) In the camera.
- (iv) During processing of the film.

It is evident that there is a danger of static discharges marking the film on all occasions when it is handled, but it is certain that the majority of such marks are likely to occur when the film is used in the camera.

In the camera itself charges may arise from separation charges at the feed spool or by friction between the film and parts of the camera.

7.1 Initial properties of the film

As mentioned in Section 4 and as would be expected from the information given in Section 2 samples of film examined in the laboratory have shown a considerable variation in their electrostatic properties. It is reasonable to assume therefore that the possibility of a spark discharge is influenced first by the particular roll of film in the camera.

7.2 Separation charges at feed spool

It is common experience that visible static discharges occur on some occasions when a roll of film is removed from a spool. Such discharges are due to separation potentials, supplemented by charges already existing within the roll as a result of friction in previous handling; in a new roll of film they are, no doubt, due entirely to separation potentials because of the relatively long time interval between handling and use.

As mentioned in Section 6, when the feed roll is insulated and the film passes over an insulated friction surface a positive charge builds up on the feed roll. In a dark room spark discharges can sometimes be observed at, or near, the feed roll under these conditions.

When film is pulled from the roll some negative charge is carried away on the film surface, but as winding continues a state of equilibrium is reached in which further separation of charge is limited by the electric field due to positive charge absorbed by the roll (see Section 6). The negative charge on the surface of film leaving the spool is then a minimum, as shown by the record in Fig.6(h). The potential difference due to separation of charge at the feed spool may be insufficient to cause sparking but since film is continuously removed from the roll its capacity falls and hence the potential rises. The intermittent spark discharges are considered to be due to the rise of potential caused by removal of film from the roll. Further, if the film conductivity is variable a more rapid rise of potential and more intense sparks will occur when film pulled off the roll is relatively conducting. When a spark discharge occurs charge is lost from the roll and the charging process is repeated to give a series of discharges while film is being removed from the roll.

In practice the effect described would occur on rolls of film which were effectively insulated from earth because the inner turns and edges of the roll had become dry. Discharges could occur at any point from the roll to the edges of the exposure frame and would be most pronounced at the roll if there was also friction between the film and an insulator such as the camera register glass.

7.3 Frictional charges within camera

It is possible that a spark discharge can occur:-

- (a) between discrete areas while rubbing is taking place without normal separation, or lift, of the surfaces;
- (b) because of the rise in potential when the surfaces are separated and
- (c) if no discharge occurs as in (a) and (b) it may still do so if the charged surface approaches low capacity earthed conductors such as sharp edges or points.

Discharge may take place during the actual rubbing when local discontinuities occur in one of the surfaces. Thus a discharge can occur as film leaves the sharp edge of a register glass or from fiducial marks engraved on the surface of the glass.

Discharges can occur when the camera pressure plate, film and register glass separate from one another just before the windover occurs.

The major factor in this case is the change of capacity and the resultant increase in potential. It is also possible that the raising and lowering of the pressure plate may increase the charges by induction. In the experiments described in this note, in which the friction has been continuous, no induction effects have been experienced. In Fig.5, if a plate of insulating material is placed above and parallel to the original cork-faced plate, to simulate the register glass of the camera, the production of charge is not affected. This is true whether the upper plate rubs the film either intermittently or continuously. For example,

if the lower plate is earthed the measured charge passing away on the film to the take-up spool is the same as though the upper plate were not present. It would appear from this that any induction effects operating are masked by the frictional effects on the film (see end of Section 2).

The chance of a discharge occurring between film and pressure plate is not appreciably affected by the insulation or earthing of the pressure plate, since the potential difference is not changed (Fig.8). On the other hand, the possibility of discharges to other parts of the camera might be reduced by choice of the resistance to earth of the pressure plate or other rubbing surfaces. Thus the maximum potential, positive and negative, to earth will be halved if the resistance to earth has a value of about 0.5×10^{11} ohms (Fig.8).

Rose⁸ has shown that mere insulation of the rubbing surfaces is insufficient. He describes some air photography in which certain cameras were provided with insulating celluloid covers over the pressure plate and bakelite strips over the metal edging of the register glass, while other cameras used during the same period were unmodified. Records of 75 rolls used in the modified cameras compared with 909 rolls used with the unmodified cameras showed that cameras provided with insulation had 8% of the rolls marked with static while the unmodified cameras had 19% of the rolls affected. However, the static marks experienced with the modified cameras were more severe and classing the marks as "slight", "medium" or "considerable", 6% of the modified cameras had considerable static as compared with 4% for the unmodified cameras. In some further limited photography with cameras provided with insulated rollers, used in conjunction with cameras provided with the normal metal rollers, static marks were obtained with the insulated rollers only. In this case it was evident that the static was directly due to the insulated rollers since the marks on the film coincided with the ribs on the rollers.

In the case of the take-up spool, with film passing over an earthed friction surface, charge tends to build up on the spool when the leakage to earth at the spool is small, but the process of winding on the film is unlikely to promote a discharge on the roll since the surface potentials fall as the film goes into the roll because of the increase in capacity. No discharges could be observed on either the feed or the take-up spool when the film was wound over an earthed friction surface.

Other discharges can take place from the charged surface of the film as it passes parts of the camera, particularly at points and sharp edges, or other low-capacity earthed electrodes. Discharges of this nature are likely both from negatively and positively charged film, i.e. from film approaching the friction surface and from film leaving the friction surface. However a discharge is more likely to take place from the positively charged film since the sparking voltage required for a small gap is less when the low-capacity electrode is negative.

In rolls of film spoiled by static the marks usually start about halfway through the roll. The main reason for this is considered to be the change in the insulation to earth at the spools as the film is transferred. Thus before the camera is operated the resistance to earth via the feed spool is a maximum while at the take-up spool it is a minimum. As the film is transferred between the two spools the feed spool resistance decreases and the take-up spool resistance increases, the resistance of the two leakage paths being equal when the spools are half full, the total resistance to earth then being a maximum. With the high insulation associated with dry film the effect would not be important but, from the work of Rose⁸, dry film, although it gives minimum loss of charge, does not give maximum production of charge. Fig.6(a) and (c)

illustrate that in the case of friction on an earthed surface the charge is higher when the spools are insulated. The major factors controlling the film conductivity are temperature and humidity; possibly they also change the rate of charge separation. Thus, considering the optimum condition, positive charge on the film after it has rubbed the pressure plate (earthed) leaks to earth at the take-up spool and fails to produce a spark discharge, but when the spools are half-full the resistance to earth is a maximum and the leakage rate is reduced to a minimum. Under these conditions the charge densities and the possibility of spark discharges are a maximum.

As mentioned at the beginning of the note, the present investigation does not cover details of the actual spark discharge. Little information on this subject is available from other sources. The Kodak Co. in America have stated that the forked marks on the film are caused by a negative charge on the film; while the hazy spots (see Fig.2(a)) are caused by a positive charge on the film. The Company also stated that a definite liberation of light energy is necessary to mark the film.

There is little doubt that the discharges causing marks on the film are largely a surface phenomenon, although in extreme cases the potential differences may be sufficient to cause breakdown of the base material. The voltage required to do this is 2 Kv (r.m.s.) per mil at 20°C and 50% R.H. The mean thickness of the film is about 0.0065 inch so that the breakdown voltage will be about 13 Kv (r.m.s.), i.e. a D.C. potential of about 18 Kv would be required. This is twice the value of anything measured in the present experiments where the measured values would be higher than those obtaining in a camera for the same charge density.

8 Test of manufacturers "Anti-static" film samples

Five samples were received from Messrs Kodak and one from Ilford Ltd.

The samples from Kodak had the treatment applied to the emulsion side only. The nature of the treatment has not been described by the manufacturer.

The sample from Ilford was provided with a conducting backing consisting of a thin layer of graphite applied in a coating of resin. The resin is soluble in an alkaline solution and the graphite is intended to come off with the resin when the film is processed.

8.1 Method of testing

It was decided to assess the static properties of the samples in accordance with:-

- (i) the relative potentials produced during unspooling after removal directly from the manufacturers sealed tin,
- (ii) the relative potentials induced on the friction plate as the film passed over it (see Fig.5(b)) and
- (iii) the quantity of charge which leaks away when the plate is earthed.

In measuring the unspooling potentials, test (i) above, the film is wound directly between two spools without friction on the plate; the measuring probe of the electrometer is placed 2 cm from the edge of the film and 10 cm out from the spool axis.

The potential to which the plate is raised is measured in a separate test by placing the probe 2 cm from a small disc, 3 cm in diameter, attached to the plate.

The charge passing to earth is measured by connecting a 56 megohm leak to the plate and the voltage drop over this resistance being proportional to the current, and the product of current and time proportional to the total charge separated by friction. The charge was recorded by a small integrating meter used in conjunction with the apparatus shown in Fig.4.

Temperature and humidity were constant during any one set of tests. For all the tests the temperature was 19° to 20°C and the relative humidity was between 50 and 55%.

8.2 Results of tests

The results of the unspooling tests are shown in Fig.9; the peak potential for each sample is taken from these curves and shown in the first column of Table II.

The potential to which the plate is raised by each sample when friction is on the back of the film is shown in Table II; the corresponding values for the emulsion side of the film are shown in Table III. These are average values of relative potential taken by means of the integrating meter, each figure is a mean of three tests.

The charge which leaks to earth at the plate when friction is on the film back is shown in the last column of Table II. The values when friction is on the emulsion are shown in the last column of Table III. Each figure is a mean of three tests.

8.3 Method of assessment

Before making any assessment of the various samples the following points are noted:-

- (i) The figures given for potential are merely for comparison with the value obtained from standard film under the same test conditions. They are not equivalent to the potential differences which may exist between the film and various parts of the camera when the film is used in a camera. Standard film is known to be capable of producing discharges which mark the film, so any film which has similar characteristics will behave similarly.
- (ii) If the polarity of charge from separation at the spools is of opposite sign to that induced by friction on the plate, then it will tend to lower the measured plate potential because of local leakage over the film surface. However, there may be an increased chance of discharges at the feed spool with a film having these characteristics for positively charged film will be approaching a negatively charged register glass.
- (iii) The data in the different columns of the table were taken at different times and hence one column of figures cannot be compared with another. The temperature and humidity were similar throughout all the tests but the film surface conditions may have been quite different. As an example, the total charge when friction was on the emulsion appears to be greater than when friction was on the film back; the data shown cannot be accepted as showing this effect; no separate test has been made in the present work.

The intensity of any marks made by static discharges on the film is likely to be proportional to the energy available, i.e. to $\frac{1}{2} QV$ where Q is the quantity of electricity taking part in the discharge and V is the potential difference between the spark gap surfaces. The samples are first qualified as capable of producing a sparking potential if the potentials measured are of the same order as that of standard film. Each sample is then allocated an energy factor which is the sum of the product of potential and charge for the emulsion and potential and charge for the back of the film.

In Table IV the energy factor found for the sample of standard film used in the tests is expressed as 100 and listed with the corresponding figures for the samples. The potentials developed by the Ilford graphite film are so low compared with standard film that it is considered unlikely that sparking potentials would be developed under normal conditions. From the results it is obvious that the treatment to one side of the film has also affected the potentials developed by the other side. The most likely explanation of this is that the conductance to earth via the spools has been increased by increased conductivity on one side of the film. Whatever the explanation, the application of the results is not affected since the arrangement of the test rig is similar to a camera and the same result would therefore obtain when the film is operated in a camera.

The sample least likely to give trouble from static discharges is the Ilford graphite-backed film. Of the Kodak samples, No.4371 should prove relatively free from static troubles.

It is important to note that although increased conductivity of the film will eliminate it as a source of static electricity it may still be marked by discharges if it rubs on insulated parts of the camera such as the register glass or insulating rubber rollers.

8.4 Photographic processing of Ilford graphite-backed film

The graphite backing is not strictly "soluble" in developer, but in presence of alkali the resin vehicle is softened and can be removed by gentle rubbing or by a water-spray. Without mechanical assistance, however, the backing remains on the film. Experiments were made with dish and machine development to simulate practical processing conditions. A 25 foot roll was processed on the Continuous Film Processing Machine Mark 5 (no spirit bath). Part of the backing came off in the developing fixing and washing tanks but an appreciable quantity remained to be removed by the squeegees. While very little trace was finally left on the film it is not considered that continuous running would be satisfactory because the squeegees would rapidly become clogged. In dish experiments simulating spool-tank development it was found that except in areas where the film had been handled or rubbed the backing did not come off and special wiping under water was necessary to remove it. Sufficient film was developed to simulate 5000 feet of $9\frac{1}{2}$ " wide film processed on the continuous machine, and the accumulation of graphite sludge was such that special filtration would obviously be necessary, especially in a spray machine such as the Type 6.

While this first experimental backing is not a practicable expedient, the principle should be given further test.

9 Applications to cameras and film

9.1 Camera design for use with standard film

- (i) When the film is wound over between exposures the clearance between the pressure plate and the register glass should be as large as possible. If we assume the film to be flat and without sag it should lie approximately midway between the pressure plate and register glass surfaces.
- (ii) The lifting mechanism of the pressure plate should ensure that in the retracted position the plate surface and the register glass surface are parallel.
- (iii) The switch or contact mechanism controlling operation of the camera motor should ensure that there is no possibility of film movement except when the pressure plate is fully lifted.
- (iv) The feed spool should not be permitted to over-run at the end of the windover. Some form of brake actuated by the tension in the film should be provided.
- (v) With regard to the material used for facing the pressure plate no definite recommendation can be made at the present stage. With standard film the greatest production of static charge can be expected at this point for two reasons:-
 - (a) The "bowing" of the film tends to increase the possibility of large-area contact with the pressure plate.
 - (b) The back of the film, which faces the pressure plate, is the surface most likely to produce large charges under all but very dry conditions.

From the information available at this stage, a suitable material should have the following characteristics:-

- (c) It should have a surface resistivity which changes with temperature and humidity in much the same way as does the film base and such that the resistance to earth from a piece of conducting film resting lightly on the surface is about 0.5 to 1.0×10^{11} ohm at 20°C and 50% R.H. The resistance to earth of the pressure plate on the F.49 camera is 0.5 to 1.0×10^8 ohm only.
- (d) The charge which it induces on the film base material should be as small as possible. No experimental work has been done on different plate facing materials and surface contours. It is noted that cork is particularly effective in producing static charges and that the conducting cork facing used on the F.49 camera is bad in this respect.
- (vi) With the exception of the feed roller(s) and the measuring roller, other points of contact with the film can and should be eliminated. All the rollers should be faced with the same material as the pressure plate, or with a material having similar characteristics.
- (vii) Corners and edges of all parts in contact with or near the film should be radiused to smooth contours and surface finish.

- (viii) The normal surface resistance of the register glass should be reduced to much the same value as the pressure plate. The problem is more difficult because a durable conducting film which does not impair the light transmission must be provided. The most likely process is one in which a transparent coating of stannic oxide or bismuth oxide is applied to a heated glass surface. The light transmission is unlikely to be affected by this process but there is some doubt whether the exact degree of conductivity could be obtained.

9.2 Camera design for use with conducting film

- (i) If the film is conducting on both sides, i.e. the resistivity is less than 10^{10} ohm/unit sq on both sides, then all the camera parts likely to be rubbed by the film should be conducting also. With the parts concerned making light contact with the conducting film, the resistance to earth should be less than 10^{10} ohm.
- (ii) With film which is conducting on the emulsion side, the register glass should be made conducting as described in Section 9.1 (viii), but in this case a high degree of conductivity can be accepted provided that the treatment does not impair the light transmission of the glass.
- (iii) If the film back is conducting, rubber coverings used for rollers to increase adhesion with the film, should be of conducting rubber similar to that manufactured by the Dunlop Rubber Co. This rubber is made relatively conducting by a modification of the methods used to incorporate the carbon black during manufacture.

The conducting rubber cannot be recommended for a camera using standard film since its conductivity would need to be controlled to quite close limits. Although it is possible to grade the conductivity of the rubber in its initial state, there are large changes of resistivity with temperature and surface stress.

9.3 Camera film

The following recommendations are made in connection with camera film:-

- (i) The surface resistivity of the film back, and preferably also of the emulsion, should be reduced so that it is not more than 10^{10} ohm/unit sq under any conditions. A treatment of the film which reduced the resistivity to 10^{11} ohm/unit sq would be useful but it is doubtful whether values higher than this would give sufficient relief to justify the costs of the additional processing of the film in manufacture.

The further recommendations, (ii), (iii) and (iv) are less effective alternatives to (i).

- (ii) Considerable relief, and probably complete relief under most conditions, would be given if the film back resistivity only were reduced to the value recommended in (i). In this connection it is recommended that further work should be done on the Ilford graphite-backed film to improve the

solubility of the coating and possibly to reduce the amount of graphite applied. This recommendation is conditional on the graphite coating process proving economic and no better form of conducting film being available.

- (iii) Further tests of samples of Kodak "anti-static" film No.4371 should be made. The Kodak Co. have not made known the treatment given to their samples except to state that the emulsion side only has been treated.
- (iv) The back of the film base material should be treated so that the film is flat under all conditions, to reduce the chances of rubbing during passage between the pressure plate and the register glass of the camera. In this connection it is noted that the graphite-backed film is considerably flatter than normal film.

10 Future investigation

If it is accepted that the only real solution to the problem is to make the film and certain camera parts more conducting, then future work should be devoted to methods of increasing this conductivity. If the conductivity of both sides of the film can be conveniently increased so that the surface resistivity is not greater than 10^{10} ohm/unit sq, then simple resistance measurements are adequate in deciding whether an "anti-static" film is acceptable.

If only slight conductivity and/or other changes in the film characteristics are economic commercially, then test of samples should be based on the principles outlined in Section 6.

Other lines of investigation which may prove useful are:-

- (i) Details of the discharge such as:-
 - (a) the energy required,
 - (b) the film surface condition,
 - (c) the side of the film on which it takes place,
 - (d) the potential difference required,
 - (e) induction effects.
- (ii) Suitable facing materials or surface treatments for plates, such as the pressure plate, where friction cannot be entirely avoided.
- (iii) The possible use of "de-staticisers", which produce ionisation of the air in the magazine. The Shirley "de-staticiser" used in the nylon industry produces ionisation and is very effective in causing charge to leak away. The objections to its use in a camera are that it requires 12 Kv positive and negative potentials; moreover it is not clear that it would prevent discharges during actual rubbing. Preliminary tests with thermionic ionisation have not been very promising. Radio-active methods have not proved suitable¹. Spark-gap ionisation also requires a high potential supply to each camera.

11 Conclusions

The primary conclusion is that static electricity discharges will not be eliminated except by increasing the conductivity of the film and of the insulating components of the cameras.

More detailed conclusions are as follows:-

- (1) The discharges are local surface phenomena which occur during friction, or when the surfaces part during friction, or when the charged film approaches sharp edges or points immediately after friction. A proportion of discharges may also occur as film is pulled off the spool.
- (2) The conditions necessary for an actual spark discharge are critical. They occur when the numerous factors affecting the production and retention of charge combine to give an optimum charge density and associated capacity.
- (3) To produce charges it is necessary for one only of the friction surfaces to be a good insulator. In practice this may be the back of the film, the register glass, the rubber-covered measuring roller or similar items.
- (4) The film emulsion is not a serious source of static charge except under sustained dry conditions. The film may be marked from the emulsion side by discharges from other insulators such as the register glass in the camera. It may also be marked from the emulsion side by separation charges as film is pulled off the spool.
- (5) One of the major factors deciding whether a spark discharge will take place is the rate at which the charge can leak away from one or both surfaces.
- (6) During operation in the camera the leakage of charge is a minimum when the two spools are half full. The total insulation to earth is a maximum under these conditions and the surface potential of the film is therefore also a maximum. In practice the static marks on a roll of film have usually started half-way through the roll.
- (7) The marks on the film are usually confined to a central track along the length of the film. Where the marks are due to discharges on the back of the film this is attributed to the fact that friction is most likely in the central region because of bowing of the film arising from unequal expansion of the two sides. Where the marks are due to discharges from the register glass it is attributed to the existence of a potential gradient on the register glass and the emulsion surfaces, the resistance to earth being greater at the centre of the surfaces.
- (8) The most efficient way of preventing the discharges is to increase the conductivity of the film and of the camera friction surfaces. For practical purposes it would be sufficient to increase the conductivity of the back of the film only. Trouble from the emulsion is only likely if the film has been dried out by prolonged storage under dry conditions with imperfect sealing of the tin. Increased conductivity of one side of the film will reduce the maximum charge density on the other side by increasing the conductivity to earth via the spools (see Ilford graphite backed film, Table III).

- (9) The resistivity of the film surfaces and any insulating parts of the camera, where friction is possible, should be reduced to a value not exceeding 10^{10} ohm/unit sq. Retention of a high charge density on the surfaces would not then be possible.
- (10) The use of static-inhibiting agents on camera parts such as the register glass is not recommended. In theory their effectiveness is dependent on the application of a critical thickness of layer; because this is impracticable laboratory and field tests have not been reliable.
- (11) The production of static charge may be increased by fluctuations of atmospheric pressure, as when the aircraft changes height. In addition the discharge is facilitated by reduced pressure. It is likely therefore that the occurrence of discharges will be reduced if the camera bays are pressurised.
- (12) Laboratory test would be adequate for deciding whether given combinations of film and camera are likely to produce charges capable of marking the film. Tests on several samples might be necessary to establish the consistency of any process applied to the film, although the number of tests considered necessary would depend largely on the results obtained with the initial samples.
- (13) Any treatment of the film surfaces intended to reduce the production of static charge without increase in the conductivity is likely to prove unreliable because of contaminating surface films.
- (14) In laboratory measurements, the electrostatic properties of different rolls of film have been found to vary considerably and the occurrence of "static" in Service cameras may be influenced appreciably by the initial properties of different rolls of film and, possibly, by particular batches of film from the manufacturers.

Typical "static" marks attributed to friction in the camera are shown in Fig.2(a) while the marks shown in Fig.2(b) are considered to have occurred before the film was used in a camera. In Fig.2(b) it will be noted that some of the "trees" appear to have their origin outside the edge of the film while others appear to have been chopped off at the edge of the film. In manufacture the base material is processed in a wide roll which is then cut into widths suitable for camera film. In Fig.2(b) the obvious conclusion is that the marks occurred while the film was in a wide roll and that this roll was subsequently cut into the camera film widths.

The character and the distribution of marks in Fig.2(b) is rare and it is not suggested that any but a very small proportion of film leaves the manufacturer in this condition. The proportion of what could be termed "static-prone" film is likely to be much higher and it is to the benefit of both manufacturer and user to ensure adequate conductivity.

REFERENCES

<u>No.</u>	<u>Author</u>	<u>Title, etc.</u>
1	I.L. Thomas	Investigations into Electrical Static Markings on Aircraft Camera Negatives. R.A.E. Technical Note No. PH.421.
2	D. Bulgin	A Portable Electrometer for the Measurement of Electrostatic Charges. Jour. Sc. Inst., 22, p.149, 1945.
3	H.F. Richards	The Contact Electricity of Solid Dielectrics. Physical Review, 22, p.122, 1923.
4	E.W.B. Gill G.F. Alfrey	Frictional Electrification. Nature, Vol.163, January 29th 1949.
5	-	Anti-Static Photographic Film. Patent Spec. No.636327.
6	G.W. Graham	Reduction of Static Electricity by Means of Inhibiting Compounds. Nature, Vol.168, November 17th 1951.
7	G.P. Wakefield	Dust Box and Field Trial Test of Destatizers as used on Polystrene Luminaire Panels. Illuminating Engineering, Vol.XLVII, No.52, February 1952.
8	D.C. Rose	Some Measurements of the Electrostatic Properties of Photographic Films. Canadian Journal of Research, September 1953.
9	P.E. Shaw C.S. Jex	Tribo-Electricity and Friction II - Glass and Solid Elements. Proceedings of the Royal Society, Vol.118, 1928.
10	P.E. Shaw R.F. Hanstock	Tribo-Electricity and Friction IV and V - Surface Strain and Relaxation of Like and of Unlike Solids. Proceedings of the Royal Society, Vol.128, 1930.
11	P.E. Shaw E.W.L. Leavey	Tribo-Electricity and Friction VIII - Quantitative Results for Metals and Other Solid Elements with Silica. Proceedings of the Royal Society, Vol.138, 1932.
12	D.E. Debeau	The Effect of Adsorbed Gases on Contact Electrification. Physical Review, 66, 1944.
13	Adams	Electrets. Journal of the Franklin Institute, 204, 1927.
14	-	Anti-Static Photographic Film. Patent No.678329 (Kodak Ltd.).
15	Holmes	R.A.E. Technical Memo. No. EL.1750.

Attached:-

Tables I to IV
Drg. Nos. PH.14267 to 14277
Neg. Nos. 108604 to 108605
Detachable Abstract Cards

Advance Distribution:-

DGTD(A)
PDQRD(A)
PDSR(A)
ADSR(Records)
D Inst RD
ADRD Inst A
RD Inst PH - Action copy
TPA3/TIB - 60
NEL (Supt Aero Div)
AAEE
Director RAE
DDRAE(E)
EL Eng Dept
GW Dept
Instr. Dept
Library
Head of IAP Department
Head of Air Ph Division
Head of Opto-Mech Section
Author (Mr. J.A. Wells)
Spec Section
File
Head of Air Survey Section

TABLE I
Relative Potentials

Condition	Relative potential	Figure
Film leaving plate:-		
(a) Plate earthed, spools insulated	+100	6(a) and (b)
(b) Plate earthed, spools earthed	+75 (+40)	6(c) -
(c) Plate insulated, spools earthed	0 (-12)	6(d) -
(d) Plate insulated, spools insulated	+15 (+12)	6(e) -
Insulated plate:-		
(e) Spools insulated	-100	6(f)
(f) Spools earthed	-150	6(j)
Film approaching plate:-		
(g) Plate earthed, spools insulated	(-0.2)	-
(h) Plate earthed, spools earthed	-66 (-0.4)	6(g) -
(j) Plate insulated, spools insulated	-33 (-33)	6(h) -
(k) Plate insulated, spools earthed	-100 (-56)	- -

Note The bracketed figures are from tests on a different sample of film from that used for the voltage records shown in Fig. 6. For each sample a relative figure of 100 is assigned for condition (a).

TABLE II

Electrostatic Properties of "Anti-Static"
Film Samples (back)

Film	Peak surface potential in kilovolts during re-spooling	Average potential of insulated plate in Kv	Leakage charge from plate in micro-coulomb (through 56 MΩ)
Standard S.B.	-2.25	-3.0	-0.40
Standard after re-spooling	-2.25	-	-
Kodak 4370	-2.40	-4.2	-0.38
Kodak 4371	-1.20	-1.8	-0.18
Kodak 4372	-2.70	-3.9	-0.72
Kodak 4373	-1.65	-3.0	-0.36
Kodak 4374	+1.65	-2.1	-0.07
Ilford graphite backed	+0.03		

TABLE III

Electrostatic Properties of "Anti-Static"
Film Samples (Emulsion)

Sample	Average potential of insulated plate in Kv	Leakage charge from plate in micro-coulomb (through 56 MΩ)
4370	-2.70	-0.63
4371	-0.80	-0.37
4372	-1.50	-0.67
4373	-1.65	-0.51
4374	-2.65	-0.72
Ilford graphite backed	-0.06	
Standard	-3.25	-0.78

TABLE IV

General Assessment of Anti-Static Film Samples

Sample	Relative Energy Factor	Remarks
Ilford graphite	-	Unlikely that spark discharge potentials will develop
Kodak 4371	16	
Kodak 4373	51	
Kodak 4370	89	
Standard safety base	100	
Kodak 4372	103	

Note The energy factor for Kodak sample 4374, calculated in a similar manner, is 62, but this sample, because of the change in polarity of the charge from the feed spool, is probably the worst of the five Kodak samples.

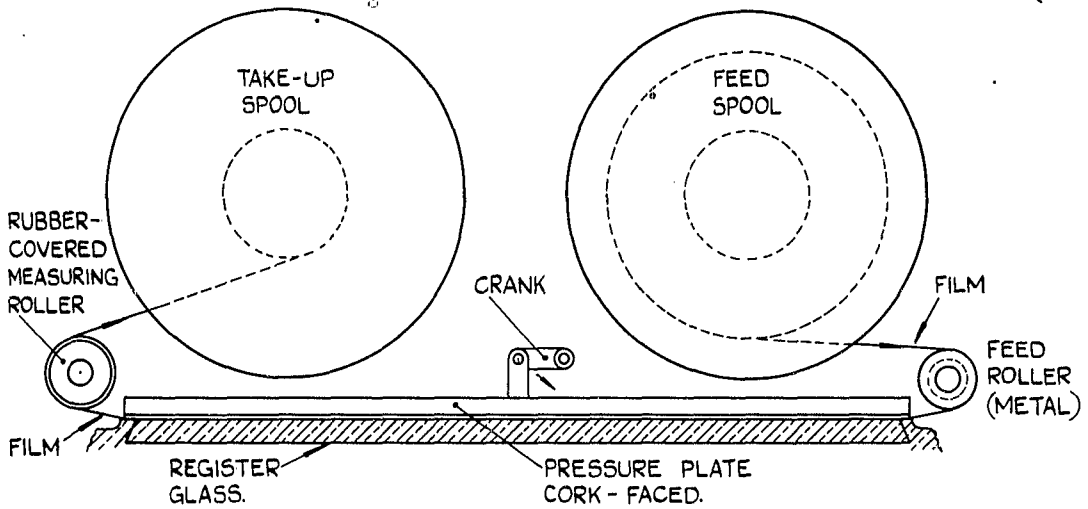

(a) PRESSURE PLATE DOWN.

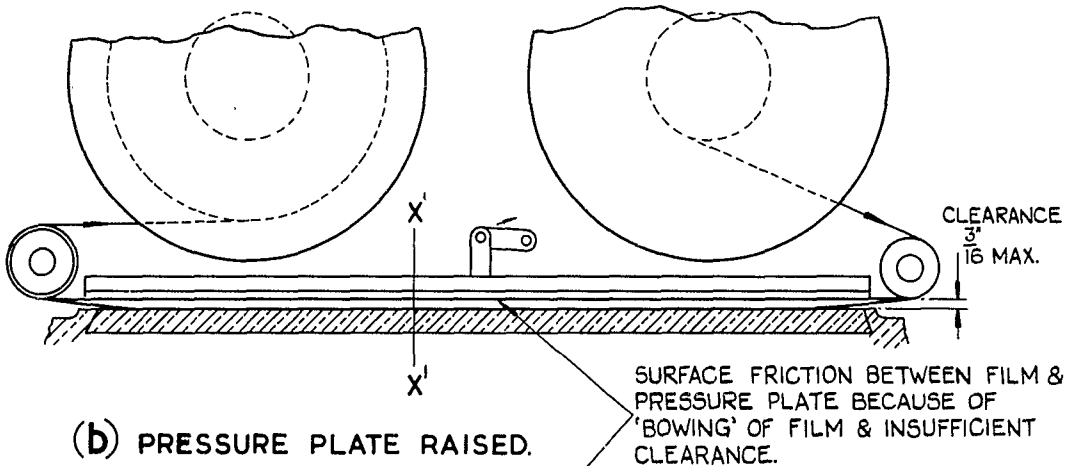

(b) PRESSURE PLATE RAISED.

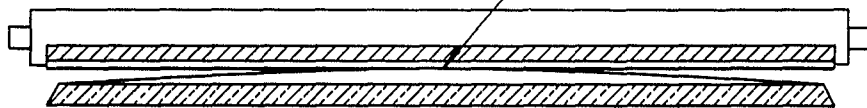

(c) SECTIONAL ELEVATION THROUGH XX' IN (b)

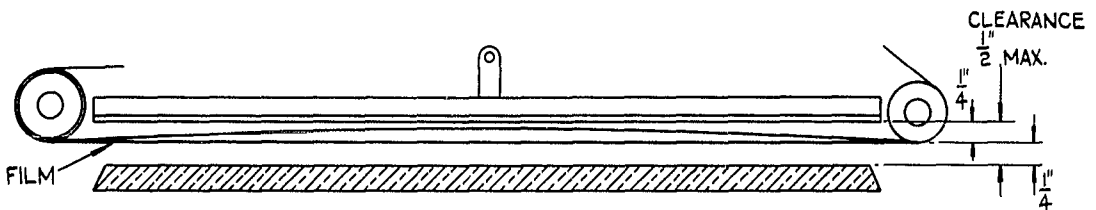

(d) INCREASED CLEARANCE OF FILM IN RAISED POSITION, GIVEN BY NEW MAGAZINE.

FIG. I(a-d) DIAGRAM SHOWING ARRANGEMENT OF FILM & CAMERA PARTS IN F.49 CAMERA.

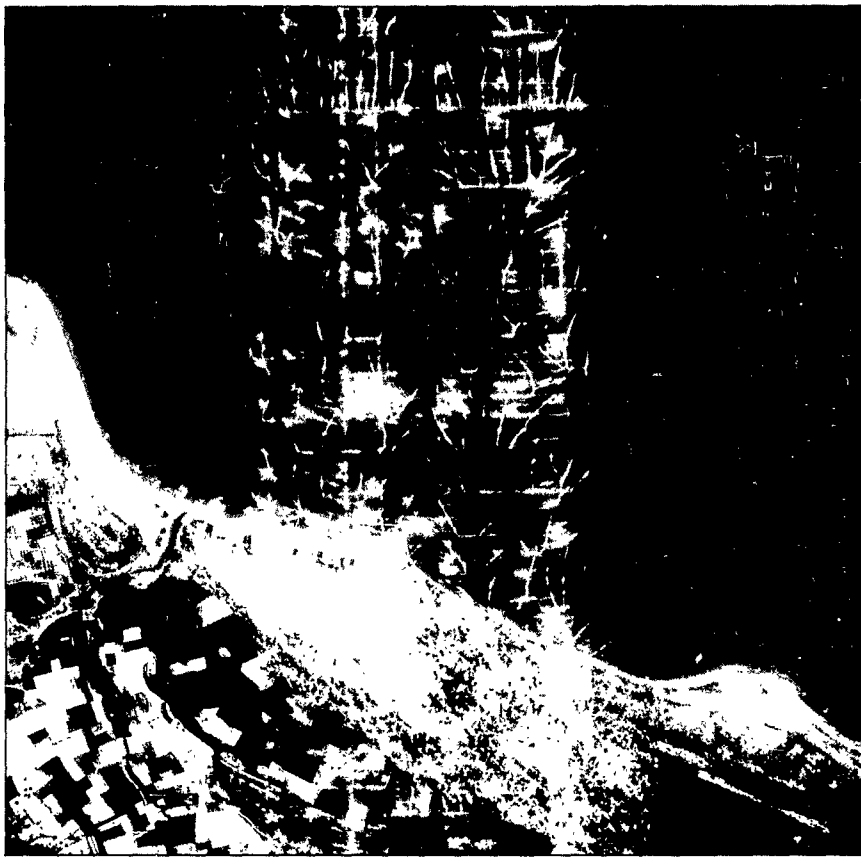

a.

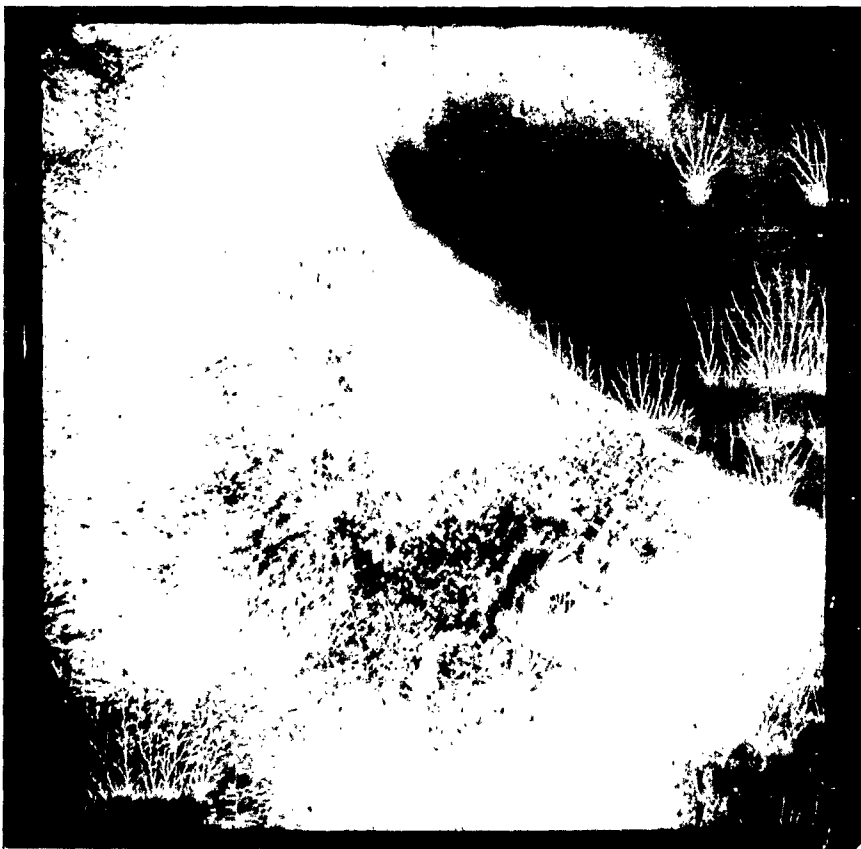

b.

FIG.2. EXAMPLES OF "STATIC" MARKS ON FILM FROM THE F.49 SURVEY CAMERA



c.



d.

FIG.2. EXAMPLES OF "STATIC" MARKS ON FILM
FROM THE F.49 SURVEY CAMERA

RAE 108605 53

FIG.3(a&b)

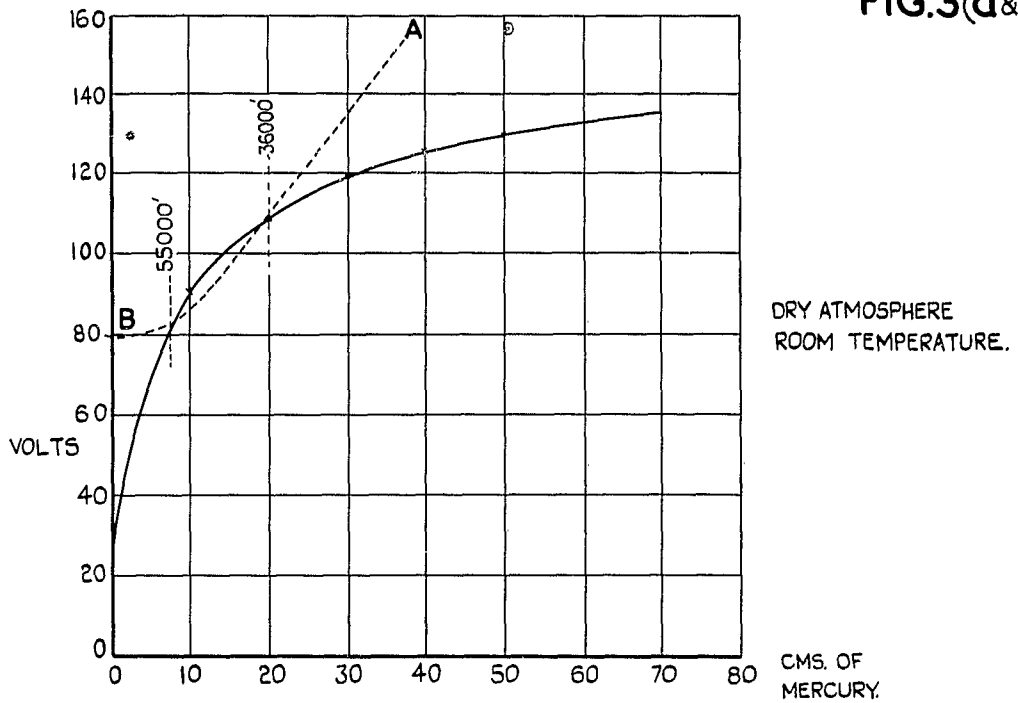

(a) POTENTIAL DUE TO FRICTIONAL CHARGES (QUARTZ-NICKEL) VARIATION WITH PRESSURE (DEBEAU)

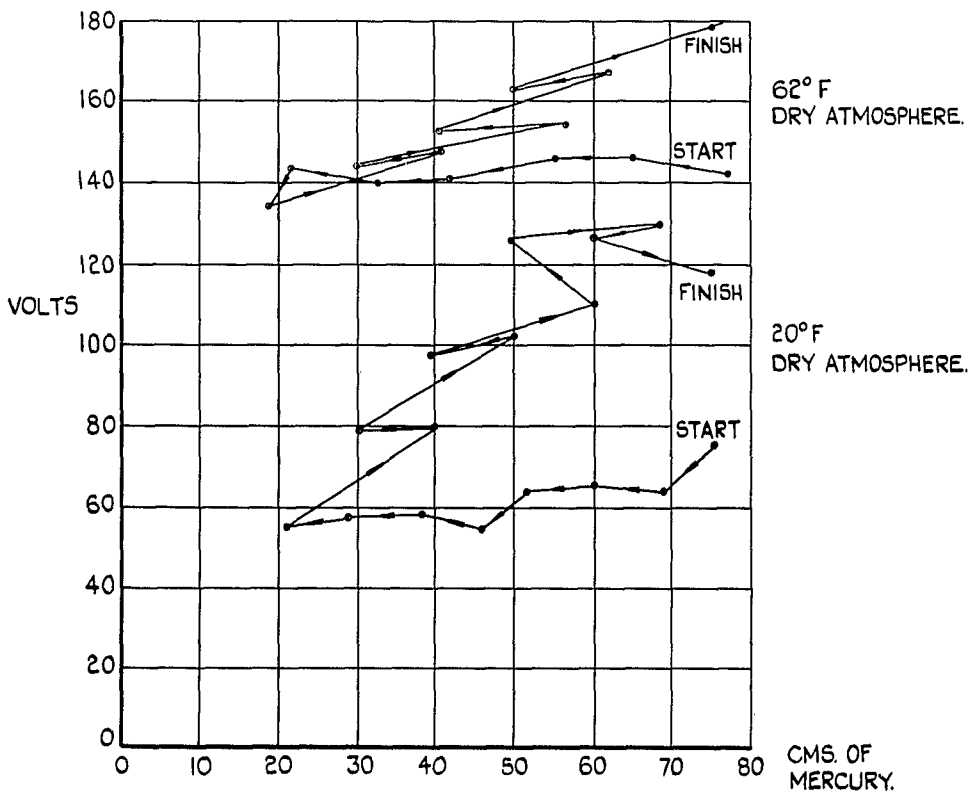

(b) POTENTIAL DUE TO FRICTIONAL CHARGES (FELT-KODAK PANCHR. FILM) VARIATION WITH PRESSURE (ROSE)

FIG.3(a&b) EFFECT OF AIR PRESSURE ON FRICTIONAL-ELECTRIC POTENTIAL.

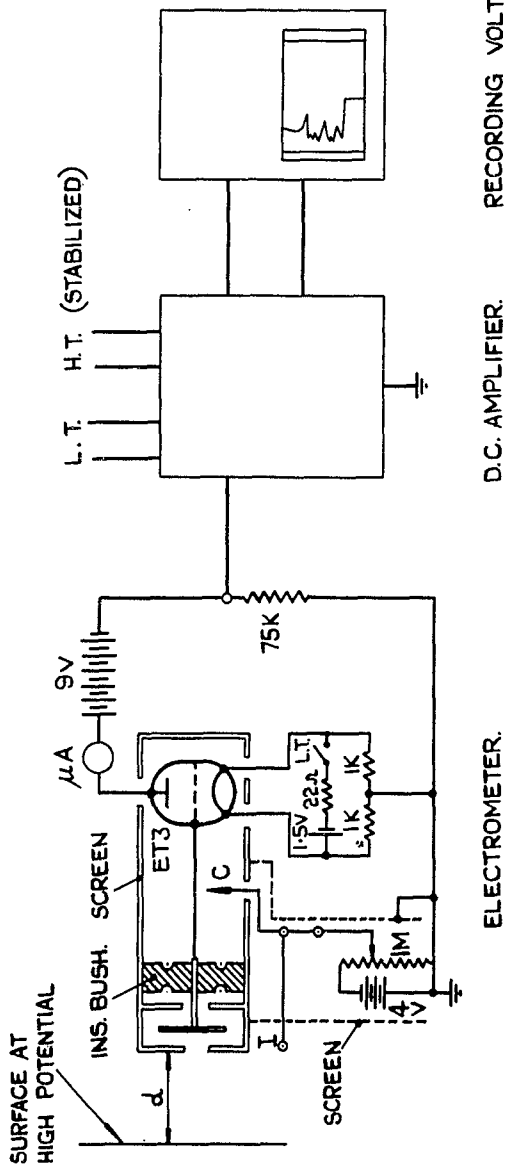

**FIG.4. APPARATUS FOR DETECTION & MEASUREMENT OF
STATIC CHARGE & POTENTIAL.**

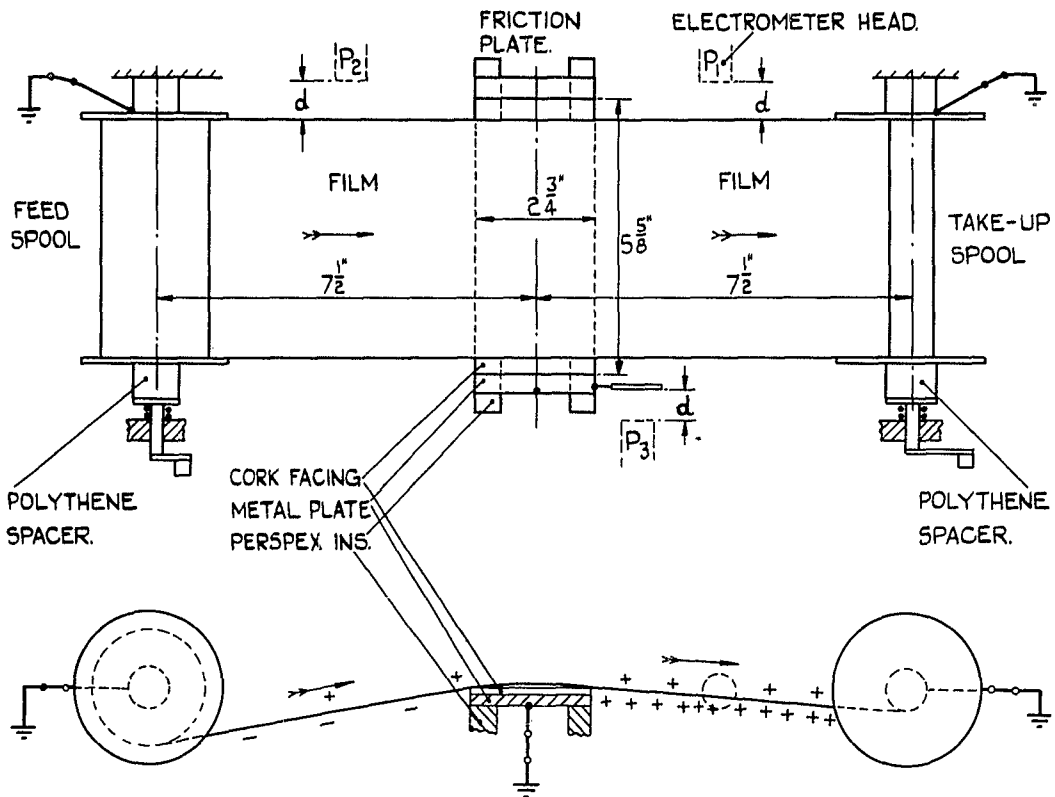

(a) DISTRIBUTION OF SURPLUS CHARGE WITH EARTHED FRICTION SURFACE.

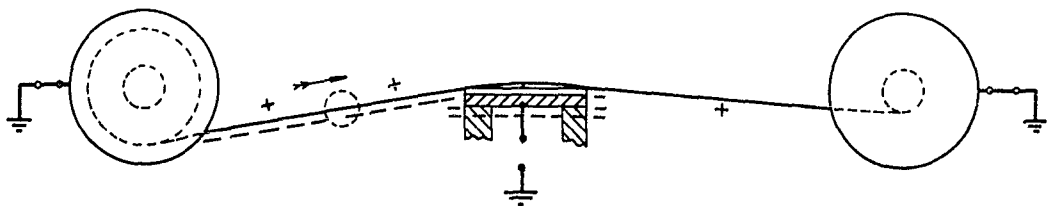

(b) DISTRIBUTION OF SURPLUS CHARGE WITH INSULATED FRICTION SURFACE.

FIG.5(a&b) APPARATUS FOR TESTING STATIC PROPERTIES OF FILM SAMPLES.

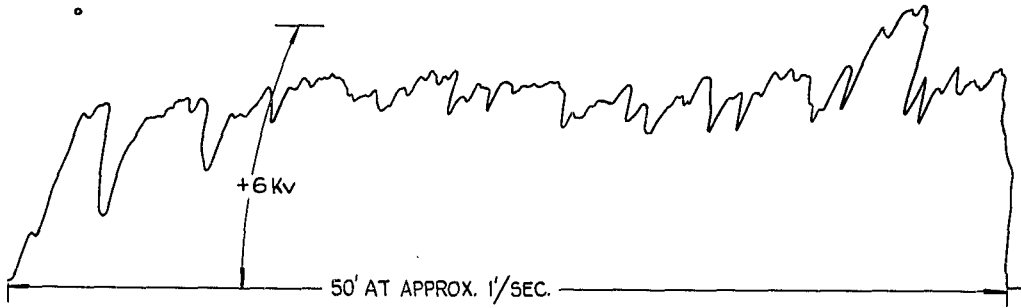

DATE: 15-12-52.

TIME: 1000 HRS.

FILM: 24³-IN NITRATE BASE,
EXPOSED, UNPROCESSED.

CONDITIONS OF TEST
20°C 40% R.H.



(a)

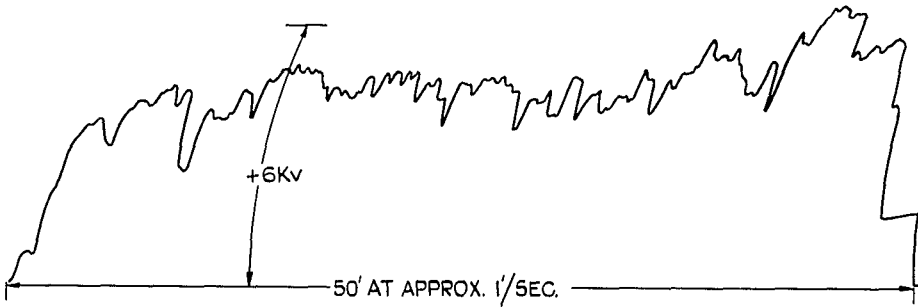

DATE: 15-12-52.

TIME: 1030 HRS.

REPEAT OF TEST (a) WITH THE
EXCEPTION THAT THE FILM SPEED
IS INCREASED BY ABOUT 10%.

(b)

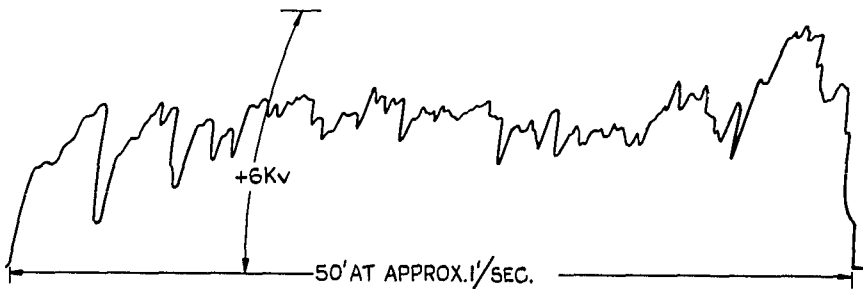

DATE: 15-12-52

TIME: 1037 HRS.

FILM: 24³-IN. NITRATE BASE,
EXPOSED, UNPROCESSED.

CONDITIONS OF TEST
20°C 55% R.H.

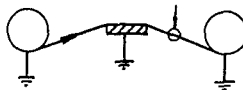

(c)

FIG.6(a,b&c) RECORDS OF SURFACE POTENTIALS ON
FILM DUE TO STATIC CHARGES.

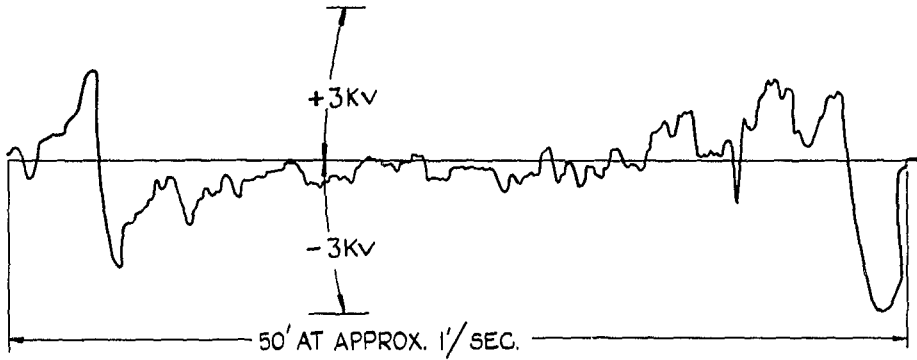

DATE: 15-12-52.

TYPE: 1050 HOURS.

FILM: 2 3/4-IN. NITRATE BASE,
EXPOSED, UNPROCESSED.

CONDITIONS OF TEST.

20°C 55% R.H.



(d)

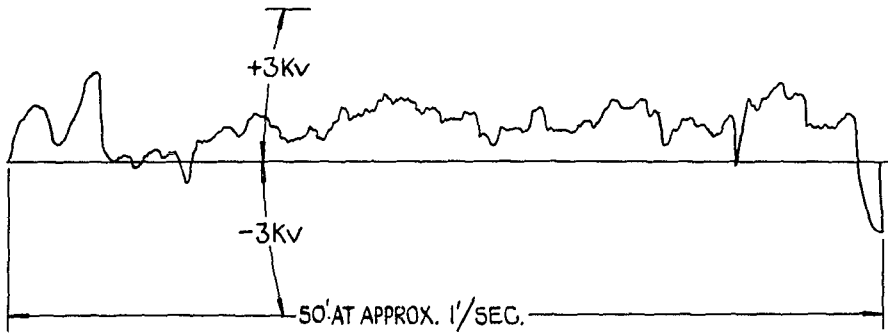

DATE: 15-12-52.

TIME: 1130 HRS.

FILM: 2 3/4-IN. NITRATE BASE,
EXPOSED, UNPROCESSED.

CONDITIONS OF TEST.

20°C 55% R.H.

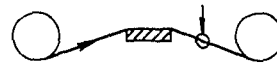

(e)

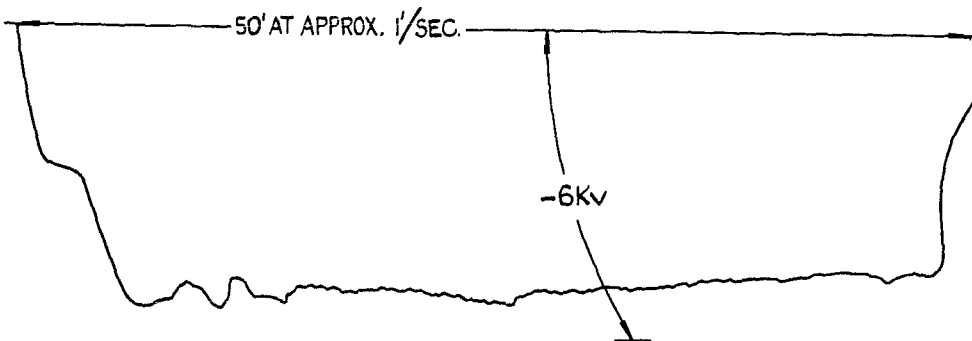

DATE: 15-12-52.

TIME: 1150 HRS.

FILM: 2 3/4-IN. NITRATE BASE,
EXPOSED, UNPROCESSED.

CONDITIONS OF TEST.

20°C 55% R.H.

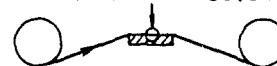

(f)

FIG.6(d,e&f) RECORDS OF SURFACE POTENTIALS
ON FILM DUE TO STATIC CHARGES.

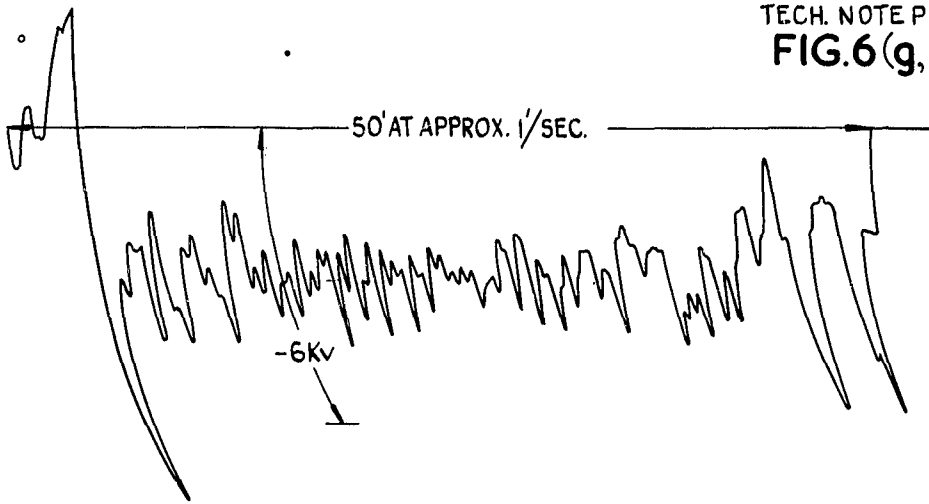

DATE: 16-12-52.
 TIME: 1115³ HRS.
 FILM: 2³/₄-IN. NITRATE BASE,
 EXPOSED, UNPROCESSED.

CONDITIONS OF TEST.
 13°C. 55% R.H.

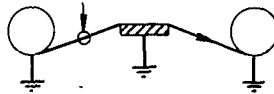

(g)

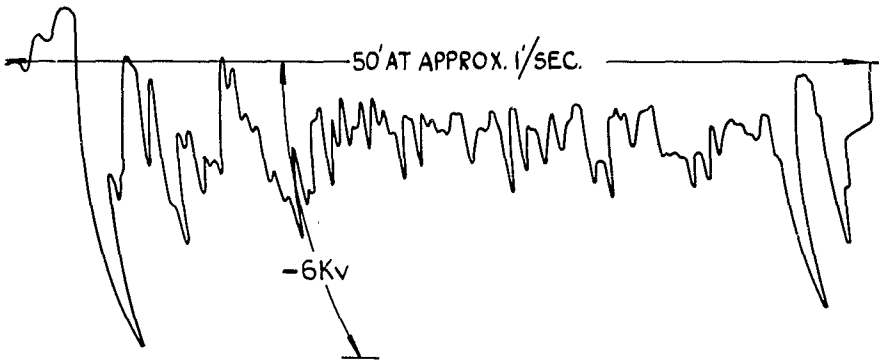

DATE: 16-12-52
 TIME: 1130 HRS.
 FILM: 2³/₄-IN. NITRATE BASE,
 EXPOSED, UNPROCESSED.

CONDITIONS OF TEST.
 13°C 55% R.H.

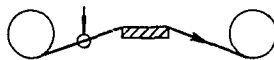

(h)

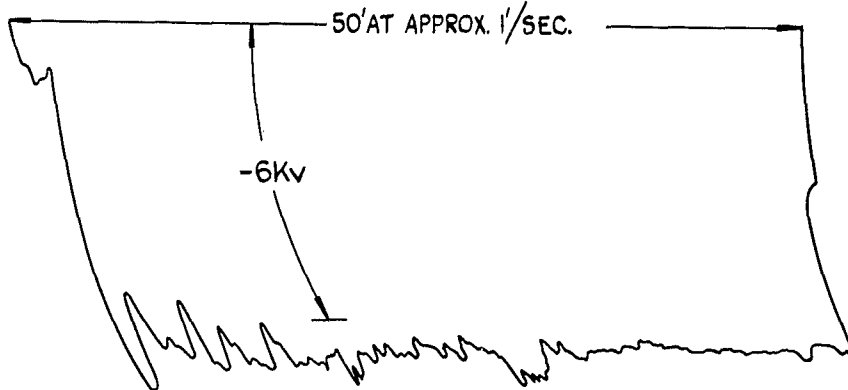

DATE: 16-12-52.
 TIME: 1050 HOURS.
 FILM: 2³/₄-IN. NITRATE BASE,
 EXPOSED, UNPROCESSED.

CONDITIONS OF TEST.
 13°C. 55% R.H.



(j)

**FIG.6(g,h&j) RECORDS OF SURFACE POTENTIALS
 ON FILM DUE TO STATIC CHARGES.**

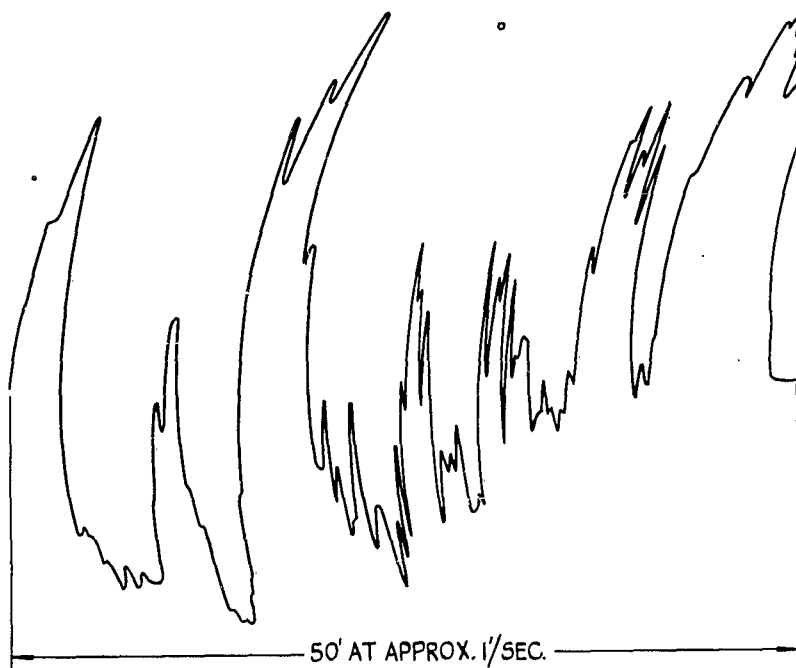

DATE: 17.12.52

TIME: 1027 HRS.

FILM: 5 1/2-IN. NITRATE BASE,
EXPOSED, PROCESSED.

CONDITIONS OF TEST.
20°C 57% R.H.

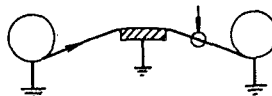

(k)

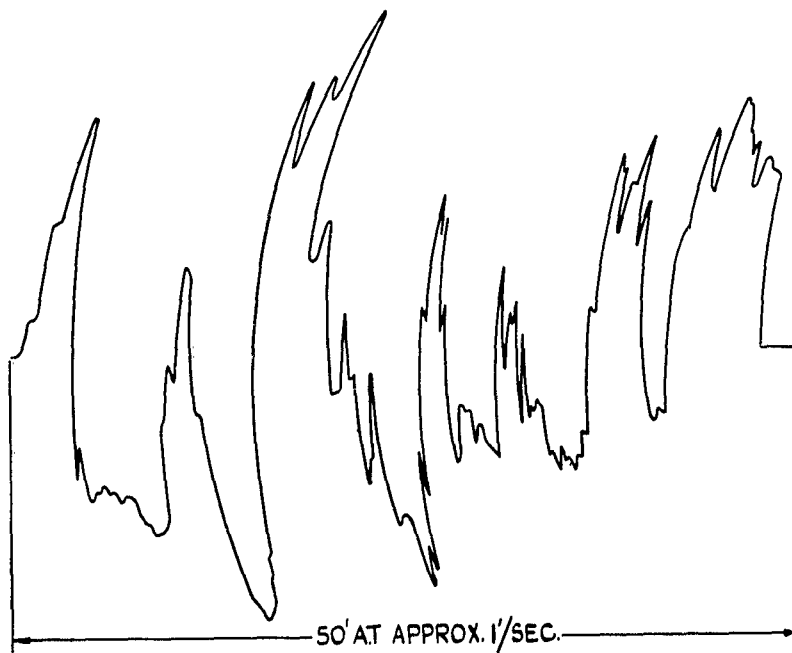

DATE: 17.12.52.

TIME: 1000 HRS.

FILM: 5 1/2-IN. NITRATE BASE
EXPOSED, PROCESSED.

CONDITIONS OF TEST.
20°C 57% R.H.



(l)

**FIG.6(k&l) RECORDS OF SURFACE POTENTIALS
ON FILM DUE TO STATIC CHARGES.**

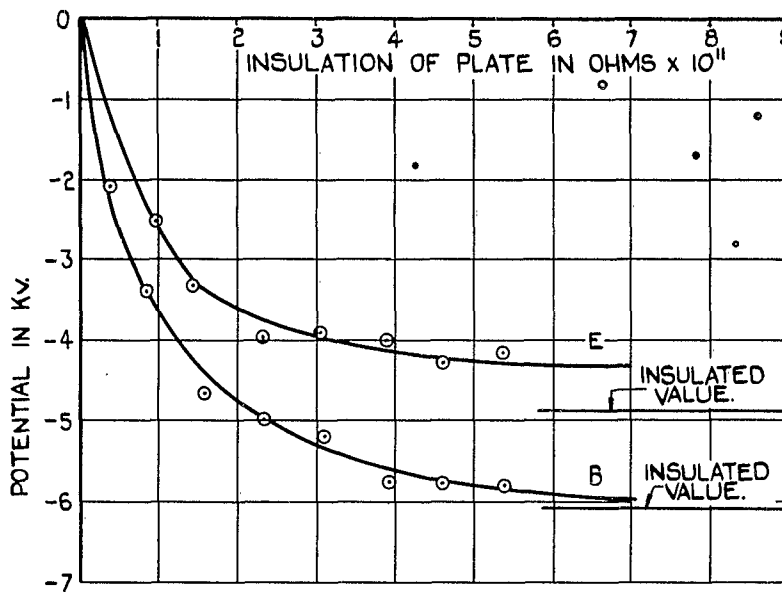

(a) VARIATION OF PLATE POTENTIAL WITH ITS INSULATION TO EARTH.

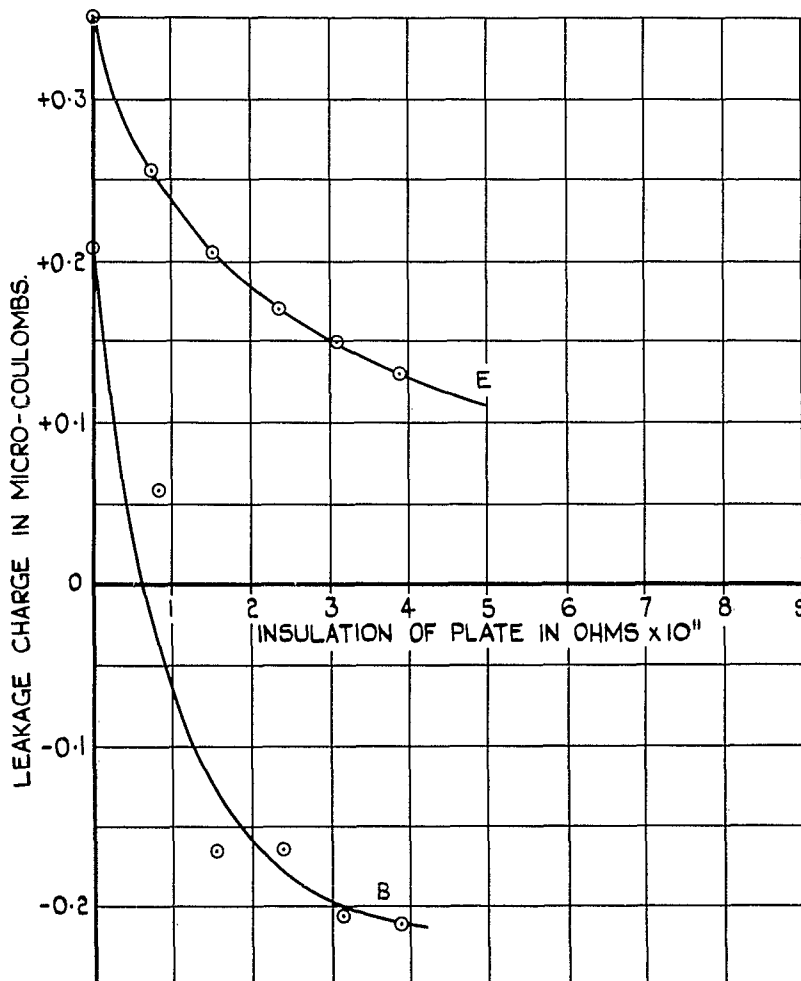

(b) VARIATION OF LEAKAGE CHARGE FROM TAKE-UP SPOOL WITH INSULATION OF PLATE TO EARTH.

FIG.7(a&b) VARIATION OF POTENTIAL & CHARGE WITH INSULATION TO EARTH OF FRICTION SURFACE.

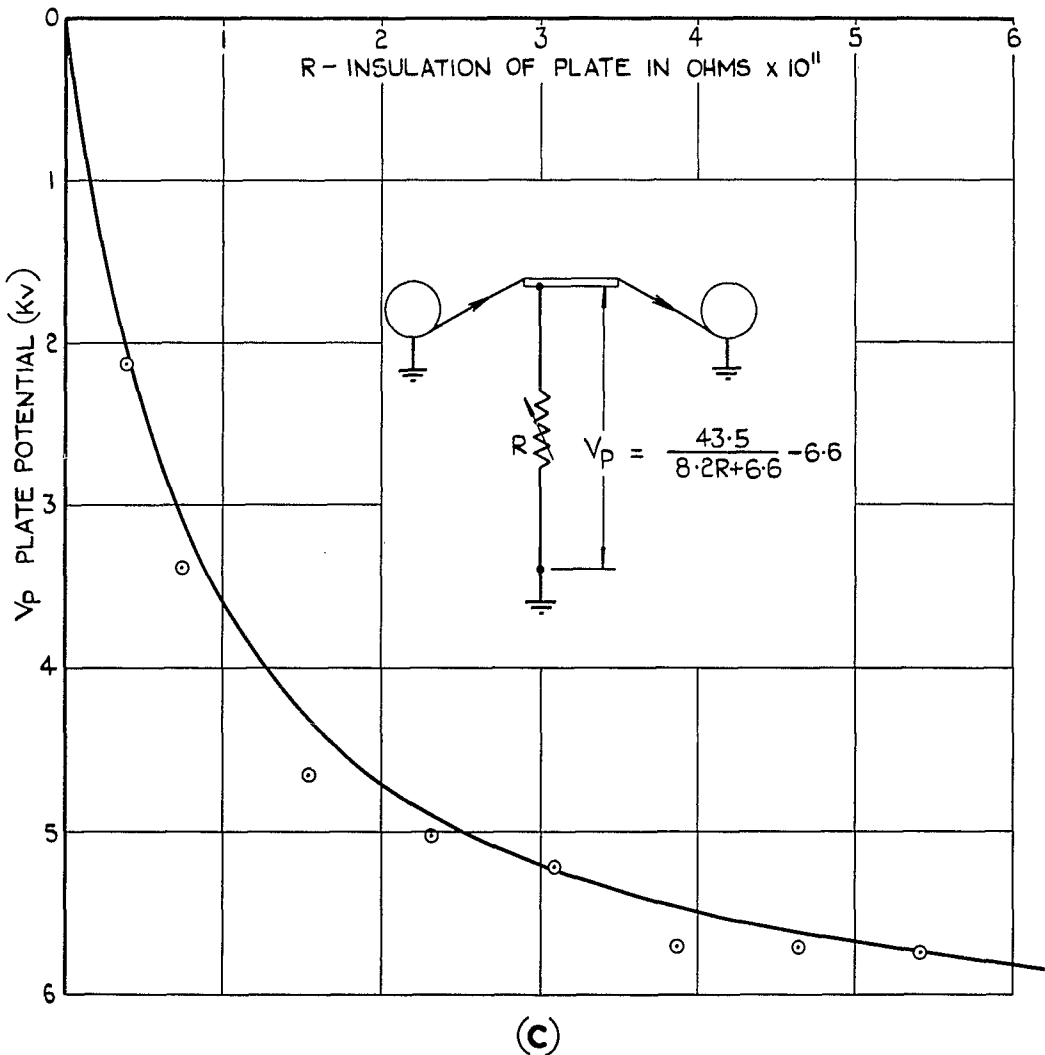
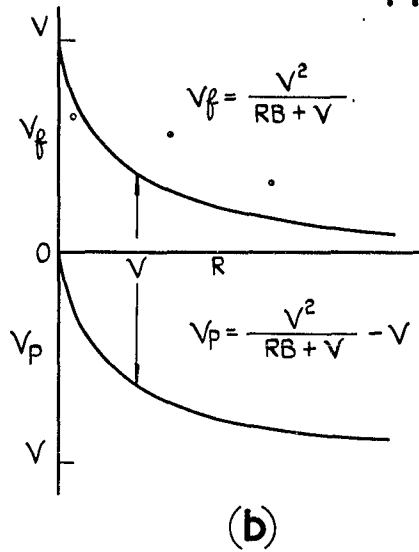
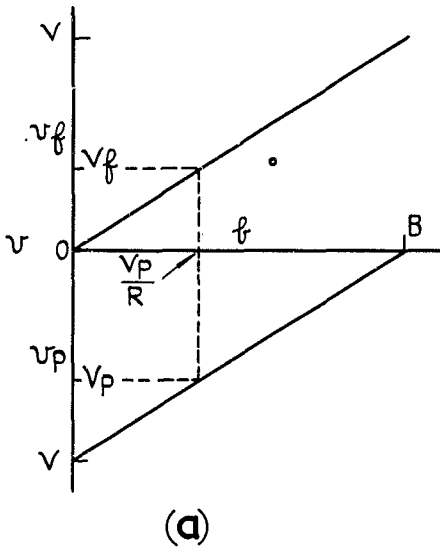
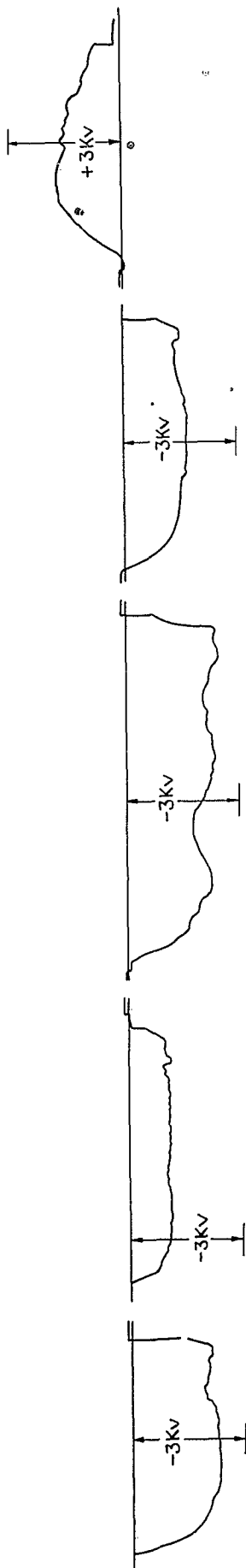

FIG.8(a, b&c) VARIATION OF POTENTIAL OR CHARGE DENSITY ON PLATE RUBBING SURFACE WITH CHANGE OF PLATE INSULATION TO EARTH.



(a) KODAK N°4370. (b) KODAK N° 4371. (c) KODAK N° 4372. (d) KODAK N° 4373. (e) KODAK N°4374.



(f) STANDARD SAFETY BASE. (g) STANDARD SAFETY BASE. (h) ILFORD GRAPHITE-BACKED. (j) ILFORD GRAPHITE-BACKED.

FIG.9(a-j) RELATIVE SURFACE POTENTIALS OF 'ANTI-STATIC' FILM SAMPLES DURING UNSPOOLING.

DETACHABLE ABSTRACT CARDS

These abstract cards are inserted in RAE Reports and Technical Notes for the convenience of Librarians and others who need to maintain an Information Index.

Detached cards are subject to the same Security Regulations as the parent document, and a record of their location should be made on the inside of the back cover of the parent document.

<p>UNCLASSIFIED</p> <p>Royal Aircraft Est. Technical Note PH.479 1953-10 Wells, J.A.</p> <p>EXPERIMENTAL WORK ON THE ELECTROSTATIC CHARGES FORMED ON AIRCRAFT CAMERA FILM</p> <p>537-22: 771-531.342</p> <p>The note gives a survey of the existing information on frictional electricity with particular reference to its application to "static" on aircraft camera film. Suitable equipment for the measurement of frictional charges is described. Some limited experimental work on the distribution of charge which occurs when a dielectric rubs continuously over a fixed surface and a method of assessing films for liability to static discharge are described. Recommendations are made for methods of reducing the occurrence of discharges.</p> <p>UNCLASSIFIED</p>	<p>UNCLASSIFIED</p> <p>Royal Aircraft Est. Technical Note PH.479 1953-10 Wells, J.A.</p> <p>EXPERIMENTAL WORK ON THE ELECTROSTATIC CHARGES FORMED ON AIRCRAFT CAMERA FILM</p> <p>537-22: 771-531.342</p> <p>The note gives a survey of the existing information on frictional electricity with particular reference to its application to "static" on aircraft camera film. Suitable equipment for the measurement of frictional charges is described. Some limited experimental work on the distribution of charge which occurs when a dielectric rubs continuously over a fixed surface and a method of assessing films for liability to static discharge are described. Recommendations are made for methods of reducing the occurrence of discharges.</p> <p>UNCLASSIFIED</p>
<p>UNCLASSIFIED</p> <p>Royal Aircraft Est. Technical Note PH.479 1953-10 Wells, J.A.</p> <p>EXPERIMENTAL WORK ON THE ELECTROSTATIC CHARGES FORMED ON AIRCRAFT CAMERA FILM</p> <p>537-22: 771-531.342</p> <p>The note gives a survey of the existing information on frictional electricity with particular reference to its application to "static" on aircraft camera film. Suitable equipment for the measurement of frictional charges is described. Some limited experimental work on the distribution of charge which occurs when a dielectric rubs continuously over a fixed surface and a method of assessing films for liability to static discharge are described. Recommendations are made for methods of reducing the occurrence of discharges.</p> <p>UNCLASSIFIED</p>	<p>UNCLASSIFIED</p> <p>Royal Aircraft Est. Technical Note PH.479 1953-10 Wells, J.A.</p> <p>EXPERIMENTAL WORK ON THE ELECTROSTATIC CHARGES FORMED ON AIRCRAFT CAMERA FILM</p> <p>537-22: 771-531.342</p> <p>The note gives a survey of the existing information on frictional electricity with particular reference to its application to "static" on aircraft camera film. Suitable equipment for the measurement of frictional charges is described. Some limited experimental work on the distribution of charge which occurs when a dielectric rubs continuously over a fixed surface and a method of assessing films for liability to static discharge are described. Recommendations are made for methods of reducing the occurrence of discharges.</p> <p>UNCLASSIFIED</p>



*Information Centre
Knowledge Services*
[dstl] *Porton Down*
Salisbury
Wiltshire
SP4 0BQ
22060-6218
Tel: 01980-613733
Fax 01980-613970

Defense Technical Information Center (DTIC)
8725 John J. Kingman Road, Suit 0944
Fort Belvoir, VA 22060-6218
U.S.A.

AD#: AD029866

Date of Search: 10 July 2008

Record Summary: AVIA 6/19107

Title: Experimental Work on the Electrostatic Charge Formed on Aircraft Camera Film
Availability Open Document, Open Description, Normal Closure before FOI Act: 30 years
Former reference (Department) TECH NOTE PH 479
Held by The National Archives, Kew

This document is now available at the National Archives, Kew, Surrey, United Kingdom.

DTIC has checked the National Archives Catalogue website (<http://www.nationalarchives.gov.uk>) and found the document is available and releasable to the public.

Access to UK public records is governed by statute, namely the Public Records Act, 1958, and the Public Records Act, 1967.

The document has been released under the 30 year rule.

(The vast majority of records selected for permanent preservation are made available to the public when they are 30 years old. This is commonly referred to as the 30 year rule and was established by the Public Records Act of 1967).

This document may be treated as UNLIMITED.