

UNCLASSIFIED

AD NUMBER	
AD030226	
CLASSIFICATION CHANGES	
TO:	unclassified
FROM:	confidential
LIMITATION CHANGES	
TO:	Approved for public release, distribution unlimited
FROM:	Distribution authorized to U.S. Gov't. agencies and their contractors; Administrative/Operational Use; 07 MAY 1954. Other requests shall be referred to National Aeronautics and Space Administration, Washington, DC.
AUTHORITY	
NASA TR Server website; NASA TR Server website	

THIS PAGE IS UNCLASSIFIED

Armed Services Technical Information Agency

Because of our limited supply, you are requested to return this copy WHEN IT HAS SERVED YOUR PURPOSE so that it may be made available to other requesters. Your cooperation will be appreciated.

AD

30226

NOTICE: WHEN GOVERNMENT OR OTHER DRAWINGS, SPECIFICATIONS OR OTHER DATA ARE USED FOR ANY PURPOSE OTHER THAN IN CONNECTION WITH A DEFINITELY RELATED GOVERNMENT PROCUREMENT OPERATION, THE U. S. GOVERNMENT THEREBY INCURS NO RESPONSIBILITY, NOR ANY OBLIGATION WHATSOEVER; AND THE FACT THAT THE GOVERNMENT MAY HAVE FORMULATED, FURNISHED, OR IN ANY WAY SUPPLIED THE SAID DRAWINGS, SPECIFICATIONS, OR OTHER DATA IS NOT TO BE REGARDED BY IMPLICATION OR OTHERWISE AS IN ANY MANNER LICENSING THE HOLDER OR ANY OTHER PERSON OR CORPORATION, OR CONVEYING ANY RIGHTS OR PERMISSION TO MANUFACTURE, USE OR SELL ANY PATENTED INVENTION THAT MAY IN ANY WAY BE RELATED THERETO.

Reproduced by
DOCUMENT SERVICE CENTER
KNOTT BUILDING, DAYTON, 2, OHIO

CONFIDENTIAL

CONFIDENTIAL

Copy 69
RM A54B15

NACA RM A54B15

AD No. 30226
ASTIA FILE COPY



RESEARCH MEMORANDUM

OPTIMUM LIFTING BODIES AT HIGH SUPERSONIC AIRSPEEDS

By Meyer M. Resnikoff

Ames Aeronautical Laboratory
Moffett Field, Calif.

CLASSIFIED DOCUMENT

This material contains information affecting the National Defense of the United States within the meaning of the espionage laws, Title 18, U.S.C., Secs. 793 and 794, the transmission or revelation of which in any manner to an unauthorized person is prohibited by law.

**NATIONAL ADVISORY COMMITTEE
FOR AERONAUTICS**

WASHINGTON

May 7, 1954

CONFIDENTIAL

54AA-32730

7 7

NOTICE: THIS DOCUMENT CONTAINS INFORMATION AFFECTING THE NATIONAL DEFENSE OF THE UNITED STATES WITHIN THE MEANING OF THE ESPIONAGE LAWS, TITLE 18, U.S.C., SECTIONS 793 and 794. THE TRANSMISSION OR THE REVELATION OF ITS CONTENTS IN ANY MANNER TO AN UNAUTHORIZED PERSON IS PROHIBITED BY LAW

L L

NATIONAL ADVISORY COMMITTEE FOR AERONAUTICS

RESEARCH MEMORANDUM

OPTIMUM LIFTING BODIES AT HIGH SUPERSONIC AIRSPEEDS

By Meyer M. Resnikoff

SUMMARY

The shapes of bodies having minimum pressure drag for a given lift at high supersonic speeds and satisfying conditions of given length and width are determined with the aid of Newton's law of resistance. The resulting shapes, as had been argued by Sänger, have flat bottoms which are, in addition, rectangular. If it is further required that, for the given conditions (both geometric and aerodynamic), the shapes have maximum volume, then they become simple wedges.

To determine if these bodies do, in fact, have improved lift-drag ratios at high supersonic speeds, several wedges satisfying numerically different sets of given conditions were tested at a Mach number of 5. Measured aerodynamic characteristics are compared with theory and with the measured characteristics of corresponding bodies of revolution having fineness ratios from 3 to 7. It is found from experiment that the wedges have maximum lift-drag ratios from 40 to 100 percent higher than those of the corresponding bodies of revolution.

INTRODUCTION

It was argued by Sänger (refs. 1 and 2) that at high supersonic speeds a lifting body having a flat bottom would have higher lift-drag ratio than one having, say, a round bottom like a body of revolution. Sänger did not, however, pursue this subject to the extent of determining the shape of an optimum lifting body; nor did he prove, for that matter, that such a body would have a flat bottom.

The determination of an optimum lifting body is normally, at best, a difficult problem because of the complexity of theories which must be employed to predict accurately the forces on an arbitrary shape. In hypersonic flow, however, a theory of remarkable simplicity becomes available, namely, the so-called impact theory of Newton (ref. 3). Newton himself pointed out that the theory should apply to flows in which the inertial forces are large compared to the elastic forces and

CONFIDENTIAL

it is now well known (see, e.g., refs. 1 and 4) that hypersonic flow tends to satisfy this condition. For application at the high Mach numbers presently of interest, say of the order of 5, the theory is, of course, only approximate. Nevertheless, it was found to be a useful tool in the determination of optimum (minimum-drag) nonlifting bodies of revolution (ref. 5). It might be expected therefore that impact theory could also be used effectively in determining optimum lifting bodies.

The objective of the present report is, then, to determine with the aid of impact theory, and subject to given conditions, a complete body shape possessing minimum drag for given lift in inviscid hypersonic flow. In addition, it is undertaken to measure experimentally the characteristics of the bodies so determined.

SYMBOLS

A	plan-form area
C_D	drag coefficient, $\frac{D}{q_0 l w}$
C_L	lift coefficient, $\frac{L}{q_0 l w}$
D	foredrag
d	base diameter of body of revolution
f	fineness ratio, $\frac{l}{w}$ ($\frac{l}{d}$ for bodies of revolution)
L	lift
l	projected body length
M	Mach number
P	pressure coefficient, $\frac{p-p_0}{q_0}$
p	static pressure
q	dynamic pressure
Re	Reynolds number
S	body surface area
V	body volume

U	air-flow velocity
w	maximum body width
x,y,z	coordinates of points on surface of body (positive x axis in the direction of free-stream velocity, origin of the coordinate system coinciding with nose of body)
y(x)	one-half the lateral dimension of the body at a distance x downstream of the body nose
ξ, η, ζ	angles formed by body surface normals and the x,y, and z axes, respectively
α	angle of attack of body (for wedges, measured from line bisecting apex angle)
τ	variable of integration
θ	wedge angle

Subscripts

l,u	values on lower and upper surface, respectively
v	values on vertical portions of body surface
o	free-stream conditions

Superscripts

—	values pertaining to a comparison body
---	--

THEORY

The geometric characteristics of the optimum body will be found by a comparison procedure rather than by the customary calculus of variations. The comparison procedure will be developed during the application and is complete within this report. The method is more direct than the variational method, thus enabling constant surveillance of physical characteristics throughout the development and avoiding some of the difficult questions associated with the application of the calculus of variations in two independent variables.

The comparison is made between the physical characteristics of a given body and those of its transform.¹ The transformed body satisfies the given aerodynamic and geometric conditions. In particular, the transformation is so chosen that its application leads to a body with lift force unchanged and either leaves the drag force unchanged or decreases it. Applied to an optimum body, it is necessary that the transformation leave the drag force unchanged. The requirement that the optimum body have the same drag as its transform yields analytic statements prescribing the geometric characteristics it must have.

Lift and Drag Expressions

The well-known impact theory expression for local pressure coefficient at a point on a body is (see sketch)

$$P = 2 \sin^2 \left(\frac{\pi}{2} - \xi \right) = 2 \cos^2 \xi \quad (1)$$

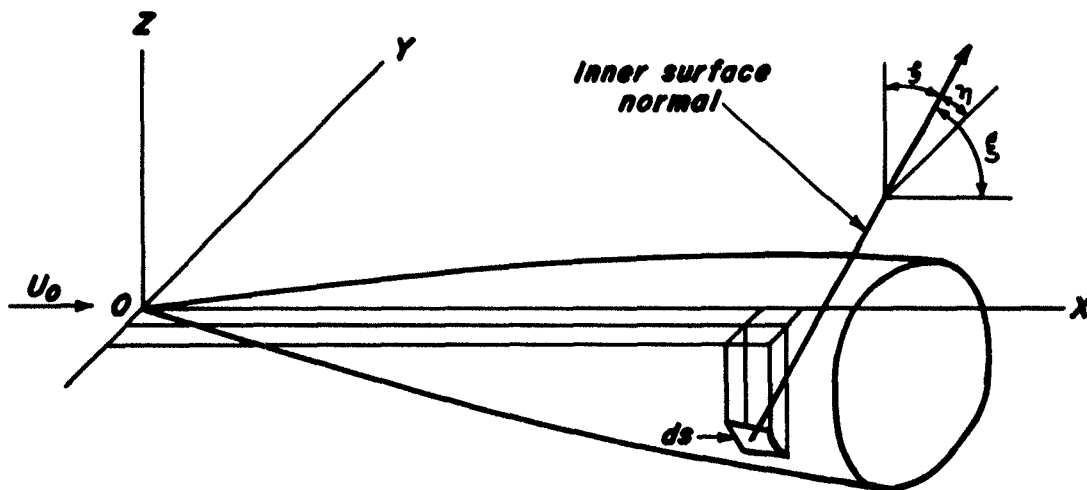

The lift and drag forces acting on an element dS of surface area are given by the projection of the force $P dS$ on the vertical (z) axis and on streamwise (x) axis, respectively, multiplied by the free-stream dynamic pressure, q_0 :

¹The comparison of given geometric configurations with properly chosen transforms leaving desired geometric or physical properties invariant has been used extensively by Polya and Szego to solve quite general problems (ref. 6).

$$dL = (P \cos \xi) q_0 dS \quad (2)$$

and

$$dD = (P \cos \xi) q_0 dS \quad (3)$$

By use of the pressure coefficient, equation (1), and the geometric relations

$$dS = dx dy \sec \xi$$

$$\cos^2 \xi + \cos^2 \eta + \cos^2 \zeta = 1$$

the lift and drag expressions (2) and (3) may be written

$$dL = 2q_0 \cos^2 \xi dx dy \quad (4)$$

and

$$dD = 2q_0 \frac{\cos^3 \xi}{\sqrt{1 - \cos^2 \xi - \cos^2 \eta}} dx dy + dD_v \quad (5)$$

where dD_v represents the drag force on a vertical surface (i.e., an area dS for which $dx dy = 0$ and $\cos \xi = 0$). The lift and drag forces acting on the entire forebody are obtained by summing the lift and drag expressions, respectively, over the forebody surface:

$$L = 4q_0 \int_0^l \int_0^{y(x)} [-\cos^2 \xi_u(x,y) + \cos^2 \xi_z(x,y)] dy dx \quad (6)$$

and

$$D = 4q_0 \int_0^l \int_0^{y(x)} \left[\frac{\cos^3 \xi_u(x,y)}{\sqrt{1 - \cos^2 \xi_u(x,y) - \cos^2 \eta_u(x,y)}} + \frac{\cos^3 \xi_z(x,y)}{\sqrt{1 - \cos^2 \xi_z(x,y) - \cos^2 \eta_z(x,y)}} \right] dy dx + D_v \quad (7)$$

where D_v represents the total of the drag forces acting on finite vertical portions of the body surface.

Development of Optimum Body Shape

Consider the optimum body satisfying the given length, width, and lift requirements and let the angles made by its upper- and lower-surface normals with the x and y axes be, respectively,

$$\left. \begin{array}{ll} \xi_u(x,y) & \eta_u(x,y) \\ \xi_l(x,y) & \eta_l(x,y) \end{array} \right\} \quad (8)$$

A second body, satisfying the given requirements of this section, will be defined in terms of the surface-normal direction angles (eq. (8)). The requirement that the drag force D of the optimum body be less than or equal to the drag force \bar{D} of the comparison body will specify geometrical characteristics to determine the shape of the optimum body.¹ Let the comparison body be two-dimensional, bounded laterally by the vertical surfaces $y = \pm w/2$, and with no forward-facing vertical surface. Let the cosines of the angles made by its upper- and lower-surface normals with the free-stream-velocity direction be given by the root mean squares of the corresponding quantities for the optimum body:

$$\left. \begin{array}{l} \cos \bar{\xi}_u(x) = \sqrt{\frac{2}{w} \int_0^{y(x)} \cos^2 \xi_u(x,\tau) d\tau} \\ \cos \bar{\xi}_l(x) = \sqrt{\frac{2}{w} \int_0^{y(x)} \cos^2 \xi_l(x,\tau) d\tau} \end{array} \right\} \quad (9)$$

With the use of the lift-force expression (eq. (6)) and the definitions of the direction cosines of the comparison body's surface normals (eq. (9)), a direct computation verifies that the lift force acting on the comparison body is equal to that of the optimum body. Similarly, the drag force acting on the comparison body is obtained by use of the direction cosines (eq. (9)) in the drag-force expression (eq. (7)):

$$\begin{aligned} \bar{D} &= 4q_0 \int_0^l \int_0^{w/2} \left[\frac{\cos^3 \bar{\xi}_u(x)}{\sqrt{1 - \cos^2 \bar{\xi}_u(x)}} + \frac{\cos^3 \bar{\xi}_l(x)}{\sqrt{1 - \cos^2 \bar{\xi}_l(x)}} \right] dy dx \\ &= 4q_0 \int_0^l \frac{w}{2} \left[(\cos^3 \bar{\xi}_u(x) + \frac{1}{2} \cos^5 \bar{\xi}_u(x) + \dots) + \right. \\ &\quad \left. (\cos^3 \bar{\xi}_l(x) + \frac{1}{2} \cos^5 \bar{\xi}_l(x) + \dots) \right] dx \end{aligned} \quad (10)$$

¹See footnote 1, p. 4.

the last expression being obtained by use of the binomial expansion of the radicals in the integral and by an integration.

In order to compare the drag force, D , of the optimum body with the drag force, \bar{D} , of the comparison body, the cosine terms in the expression (10) for the quantity \bar{D} are evaluated by use of their defining expression, equations (9):

$$\cos^{2n+1} \bar{\xi}_u(x) = \left[\frac{2}{w} \int_0^{y(x)} \cos^2 \xi_u(x, \tau) d\tau \right]^{\frac{2n+1}{2}} \quad (11)$$

Application of Hölder's inequality² (ref. 7) then gives

$$\begin{aligned} \cos^{2n+1} \bar{\xi}_u(x) &\leq \frac{y^{n-1/2}(x)}{(w/2)^{n+1/2}} \int_0^{y(x)} \cos^{2n+1} \xi_u(x, \tau) d\tau \\ &\leq \frac{2}{w} \int_0^{y(x)} \cos^{2n+1} \xi_u(x, \tau) d\tau \end{aligned} \quad (12)$$

The following sequence of inequalities results by using inequality (12), together with the corresponding expression for the lower surface, in the drag-force expression (eq. (10)), and comparing the result with the drag-force expression for the optimum body (eq. (7)):

²Hölder's inequality states that

$$\left| \int f(x) g(x) dx \right|^m \leq \int |f(x)|^m dx \left(\int |g(x)|^{\frac{m}{m-1}} dx \right)^{m-1}$$

for any value of m greater than one. Applied to the right side of expression (11) with $m = n + 1/2$, Hölder's inequality yields

$$\begin{aligned} &\left| \int_0^{y(x)} \cos^2 \xi_u(x, \tau) \frac{2}{w} d\tau \right|^{n+1/2} \\ &\leq \int_0^{y(x)} \cos^{2n+1} \xi_u(x, \tau) d\tau \left[\left(\frac{2}{w} \right)^{\frac{n+1/2}{n-1/2}} y(z) \right]^{n-1/2} \\ &\leq \frac{2}{w} \left[\frac{y(x)}{w/2} \right]^{n-1/2} \int_0^{y(x)} \cos^{2n+1} \xi_u(x, \tau) d\tau \end{aligned}$$

$$\begin{aligned} \bar{D} &\leq 4q_0 \int_0^l \int_0^{y(x)} \left(\frac{\cos^3 \xi_u}{\sqrt{1 - \cos^2 \xi_u}} + \frac{\cos^3 \xi_z}{\sqrt{1 - \cos^2 \xi_z}} \right) dy dx \\ &\leq 4q_0 \int_0^l \int_0^{y(x)} \left(\frac{\cos^3 \xi_u}{\sqrt{1 - \cos^2 \xi_u - \cos^2 \eta_u}} + \right. \\ &\quad \left. \frac{\cos^3 \xi_z}{\sqrt{1 - \cos^2 \xi_z - \cos^2 \eta_z}} \right) dy dx \end{aligned} \quad (13)$$

$$\bar{D} \leq D - D_V \quad (14)$$

Since the optimum body cannot have greater drag than another body with the same lift, the inequalities (12) to (14) inclusive must be equalities, and the drag force D_V on vertical surfaces must be zero. Thus, by expression (12), the lateral boundary, $y(x)$, of the surfaces of the optimum body must also be $w/2$ throughout the entire length of the body so that the plan-form shape must be rectangular, and by expression (13), the surface normals must always be orthogonal to the lateral axis, that is, the body is "two-dimensional." Finally, $D_V = 0$ states that the nose of the body cannot have a finite forward-facing area of infinite slope.

By an analogous procedure, with the application of a second transformation (see Appendix)

$$\left. \begin{aligned} \cos \left(\overline{\xi_u} \right) &= 0 \\ \cos \left(\overline{\xi_z} \right) &= \sqrt{\frac{1}{l} \int_0^l [-\cos^2 \xi_u(x) + \cos^2 \xi_z(x)] dx} \end{aligned} \right\} \quad (15)$$

it can be shown that the upper surfaces may not project beyond the flow shadow (hence, by impact theory, may not be subject to flow forces) and the lower surface must be planar.

To show that the body so characterized is unique (insofar as the lower surface is concerned, since this is the only surface subject to air-flow forces) and actually presents less drag than any other body satisfying the given conditions, it is noted that the consecutive application of the transformations (9) and (15) to an arbitrary body (satisfying the given dynamic and geometric conditions) always leads to a body with the same lower surface. That is, substituting transformation (9) in transformation (15) and using the lift condition (6) gives

$$\begin{aligned} \cos^2 \left(\overline{\xi}_2 \right) &= \frac{1}{l} \int_0^l \frac{2}{w} \int_0^{y(x)} \left[-\cos^2 \xi_u(x, \tau) + \cos^2 \xi_l(x, \tau) \right] d\tau dx \\ &= \frac{L}{2q_0 l w} \end{aligned} \quad (16)$$

and the inequalities

$$\left(\overline{D} \right) \leq \overline{D} \leq D$$

Thus, the optimum body characterized by the surface-normal direction $\left(\overline{\xi}_2 \right)$ (eq. (16)) possesses an absolute minimum drag characteristic. From equation (16), the angle θ between the free-stream direction and the planar bottom is

$$\theta = \arcsin \sqrt{\frac{L}{2q_0 w l}} \quad (17)$$

resulting in a drag force, at the given lift, of

$$D = L \sqrt{\frac{L}{2q_0 w l - L}} \quad (18)$$

The volumes of the bodies were not considered in the foregoing optimizing procedure. However, above the flat bottom surface of the optimum body and in the flow shadow there is a space

$$\frac{1}{2} w l^2 \tan \theta = \frac{w l^2}{2} \sqrt{\frac{L}{2w l q_0 - L}}$$

Thus, if it is desired that the optimum body have a volume V , with

$$V \leq \frac{w l^2}{2} \sqrt{\frac{L}{2w l q_0 - L}} \quad (19)$$

then the optimizing procedure applies for the additional condition of prescribed volume.³ It should be noted that if the maximum available volume is utilized, the optimum body is uniquely a simple wedge.

³A comparison of several wedges and typical bodies of revolution showed that for given lengths and width, the volumes of wedges were approximately equal to those of corresponding bodies of revolution. Thus, it does not seem probable that the bound on given volume (inequality (19)) will be appreciably exceeded by bodies of usual proportions.

Expressions (6) and (7) show that according to impact theory the dynamic forces on a flat bottom surface are unchanged by a redistribution of plan-form area. If the geometric requirements of given length and maximum width are relaxed, optimum bodies in inviscid corpuscular flow may be characterized broadly (but precisely) as having flat bottom surfaces with shadowed upper surfaces. With plan-form area specified, expression (18) shows that the drag force on a flat bottom surface, for a plan-form area A and a lift force L , is

$$D = L \sqrt{\frac{L}{2q_0 A - L}}$$

and expression (17) gives the angle θ between the free-stream direction and the flat bottom surface as

$$\theta = \text{arc sin } \sqrt{\frac{L}{2q_0 A}}$$

If it is desired that this body contain maximum volume, subject to the dynamic condition of given lift and the geometric condition of given plan-form area and shape, then the side and top surfaces of the optimum body are generated by lines passing through the boundary of the bottom surface and aligned with the free-stream vector.

EXPERIMENT

The preceding analysis, indicating that the wedge is a body with minimum drag for a given lift, is based on the simplifying assumptions of an inviscid fluid and, in effect, infinite Mach number. An experimental program was undertaken, therefore, to determine if such a body has improved lift-drag ratios in viscous air flow at moderately high but finite supersonic airspeeds. To this end, lift and drag characteristics of three optimum bodies of revolution⁴ and three corresponding wedges

⁴The profile shapes of the 3/4-power bodies are defined by the expression

$$r(x) = \frac{d}{2} \left(\frac{x}{l} \right)^{3/4}$$

where r is the radius of the body at a distance x downstream of the nose. The 3/4-power body was shown to approximate the body of given fineness ratio offering minimum drag at zero lift in hypersonic air flow (ref. 5), and under the assumption that the pressure forces in hypersonic air flow are negligible on the upper surface of a lifting body of revolution, it can be shown by impact theory that the 3/4-power body approximates the body of revolution of given fineness ratio having maximum lift over drag.

(fig. 1(a)) were investigated at a Mach number of 5 (Re per ft = 4×10^6) in the Ames 10- by 14-inch supersonic wind tunnel. The bodies of revolution had a $3/4$ -power profile and were of fineness ratios 7, 5, and 3 (fig. 1(b)). The wedges had the same lengths as the bodies of revolution and widths equal to their diameters. The wedge angles were determined so that, according to impact theory, the lift of each wedge with its upper surface in free-stream alignment was equal to the lift force of the corresponding $3/4$ -power body at the maximum point on the theoretical lift-drag curve of the latter. These wedge angles were such that the volumes of the wedges were approximately 15 percent less than those of the $3/4$ -power bodies. The testing was carried out in the manner described in the experimental investigation reported in reference 8. A detailed description of the wind tunnel and its flow characteristics may be found in reference 9. All forces are those on the forebodies only, forces on the model bases having been eliminated by correcting measured base pressures to free-stream static pressure. The estimated accuracy of the measured maximum lift-drag ratios is approximately ± 5 percent.

RESULTS AND DISCUSSION

The theoretical results show that at high supersonic speeds the flat bottom characterizes the best lifting shape. Moreover, it was shown that the flat bottom must be rectangular for the geometric conditions of given length and width. Thus, if it is desired to use all of the available volume above the flat bottom surface, the minimum-drag body for a given lift force, in inviscid hypersonic flow, is a wedge. This finding is supported by the experimental results⁵ presented in figures 2, 3, and 4. These results show that for all lift coefficients within the range of the tests, the drag of each wedge was significantly less than that of the corresponding body of revolution. The lower drag resulted in increased L/D and the maximum lift-drag ratios of the wedges were 100 percent, 42 percent, and 53 percent higher than those of the corresponding $3/4$ -power bodies for fineness ratios 3, 5, and 7, respectively.

The measured lift and drag forces and lift-drag ratios for the fineness ratio 7 wedge are compared in figure 5 with predictions based on impact theory and friction drag estimates (cf. Monaghan, ref. 10). It is seen that theory underestimates lift for a given angle of attack. Lift-drag ratio is underestimated by as much as 25 percent at the higher angles of attack. It follows that the underestimation of the drag forces is not as great, percentagewise, as the underestimation of lift forces.

⁵The force coefficients are referred to the body length times the base width, two of the given conditions, in preference to the customary base reference area used in connection with bodies of revolution.

The greater accuracy of the drag estimate is due to the fact that the drag of the wedge at the lower angles of attack is predominantly the result of skin friction. The skin-friction estimate is, apparently, more accurate than the estimate of pressure forces. It is evident, however, from figure 5 (as had been mentioned previously) that although impact theory may be somewhat inaccurate in the estimation of quantitative forces at finite Mach numbers, it is qualitatively useful for determining optimum body shapes.

CONCLUDING REMARKS

It was undertaken to determine by use of Newtonian impact theory the shape of the general minimum-drag body satisfying conditions of given lift, length, and width. It was found that the lower surface of such a body must be flat, thus verifying Sänger's speculation, and rectangular, and that if the maximum available volume is utilized, the minimum-drag body satisfying the given conditions in hypersonic inviscid air flow is a wedge. The shape so determined was tested at a Mach number of 5 for three numerically different sets of given conditions, together with corresponding optimum bodies of revolution. Results of the tests showed that the optimum shape determined by impact theory had, for three different fineness ratios, measured lift-drag ratios 100 percent, 42 percent, and 53 percent higher than those of the corresponding optimum bodies of revolution.

Ames Aeronautical Laboratory
National Advisory Committee for Aeronautics
Moffett Field, Calif., Feb. 15, 1954

APPENDIX

APPLICATION OF THE SECOND TRANSFORMATION

The drag force \overline{D} for the body resulting from the transformation (15) may be put in a form similar to that of expression (10) for \overline{D} . Integration then gives

$$\overline{D} = 2q_0 l w \left[\cos^3 \left(\overline{\xi}_2 \right) + \frac{1}{2} \cos^5 \left(\overline{\xi}_2 \right) + \dots \right] \quad (A1)$$

Because of definition (15), the representative cosine term on the right of equation (A1) satisfies the inequality

$$\cos^{2n+1} \left(\overline{\xi}_2 \right) \leq \left[\frac{1}{l} \int_0^l \cos^2 \overline{\xi}_2(\tau) d\tau \right]^{\frac{2n+1}{2}} \quad (A2)$$

Application of Hölder's inequality to the right side of equation (A2) results in

$$\cos^{2n+1} \left(\overline{\xi}_2 \right) \leq \frac{1}{l} \int_0^l \cos^{2n+1} \overline{\xi}_2(\tau) d\tau \quad (A3)$$

Substituting equation (A3) in (A1), comparing with expression (10) for the drag force \overline{D} , and using the inequality (14), there results

$$\overline{D} \leq \overline{D} \leq D \quad (A4)$$

However, D represents the drag force of an optimum body so that inequalities (A4), and hence inequalities (A2) and (A3), must be equalities for all positive integral values of the index n . This fact, together with equation (15), requires that $\cos \overline{\xi}_u(x) = 0$ and therefore, by equation (9), that $\cos \overline{\xi}_u(x, y) = 0$. Thus the optimum body may not have upper surfaces subject to flow forces. In addition, the equality (A3) for $n = 1$ yields the requirement (squaring each side and applying the definition (15) to the left side)

$$\left(\frac{1}{l} \int_0^l \cos^2 \overline{\xi}_2(\tau) d\tau \right)^3 = \left(\frac{1}{l} \int_0^l \cos^3 \overline{\xi}_2(\tau) d\tau \right)^2 \quad (A5)$$

By the Schwarz inequality⁶ (ref. 7)

$$\left(\frac{1}{l} \int_0^l \cos^2 \bar{\xi}_2(\tau) d\tau \right)^2 \leq \frac{1}{l} \int_0^l \cos^3 \bar{\xi}_2(\tau) d\tau \frac{1}{l} \int_0^l \cos \bar{\xi}_2(\tau) d\tau$$

and

$$\left(\frac{1}{l} \int_0^l \cos \bar{\xi}_2(\tau) d\tau \right)^2 \leq \frac{1}{l} \int_0^l \cos^2 \bar{\xi}_2(\tau) d\tau$$

(A6)

Using equation (A6) to evaluate the left side of equation (A5)

$$\left(\frac{1}{l} \int_0^l \cos^2 \bar{\xi}_2(\tau) d\tau \right)^3 = \frac{\left(\frac{1}{l} \int_0^l \cos^2 \bar{\xi}_2(\tau) d\tau \right)^4}{\frac{1}{l} \int_0^l \cos^2 \bar{\xi}_2(\tau) d\tau}$$

$$\leq \frac{\left(\frac{1}{l} \int_0^l \cos^3 \bar{\xi}_2(\tau) d\tau \right)^2 \left(\frac{1}{l} \int_0^l \cos \bar{\xi}_2(\tau) d\tau \right)^2}{\frac{1}{l} \int_0^l \cos^2 \bar{\xi}_2(\tau) d\tau}$$

$$\leq \left(\frac{1}{l} \int_0^l \cos^3 \bar{\xi}_2(\tau) d\tau \right)^2$$

(A7)

⁶Schwarz's inequality states that

$$\left(\int_a^b f(x) g(x) dx \right)^2 \leq \int_a^b f(x) dx \int_a^b g(x) dx$$

with the equality holding if and only if

$$\frac{d}{dx} \left[\frac{f(x)}{g(x)} \right] = 0$$

in the interval of integration.

Equality (A5) requires that the expressions (A7) be equalities, from which it follows that expressions (A6) must be equalities. But the expressions (A6) can be inequalities if and only if

$$\frac{d}{dx} \cos \bar{\xi}_2(x) = 0$$

By equation (9) this requires that

$$\frac{d}{dx} \cos \xi_2(x) = 0$$

Thus, the optimum body must have a planar bottom surface.

REFERENCES

1. Sänger, Eugen: Raketen-flugtechnik. R. Oldenbourg (Berlin), 1933, pp. 112, 120-121.
2. Sänger, Eugen, and Bredt, J.: A Rocket Drive for Long Range Bombers. Bur. Aero., Navy Dept. Trans. CGD-32, 1944, pp. 58-64.
3. Newton, Isaac: Principia - Motte's Translation Revised. Univ. of Calif. Press, 1946, pp. 333, 657-661.
4. Epstein, Paul S.: On the Air Resistance of Projectiles. Proc. Nat. Acad. Sci., vol. 17, 1931, pp. 532-547.
5. Eggers, A. J., Jr., Dennis, David H., and Resnikoff, Meyer M.: Bodies of Revolution for Minimum Drag at High Supersonic Airspeeds. NACA RM A51K27, 1952.
6. Polya, György, and Szegő, Gabor: Isoperimetric Inequalities in Mathematical Physics. Princeton Univ. Press, 1951.
7. Titchmarsh, E. C.: The Theory of Functions. Oxford Univ. Press, 1949, pp. 381-383.
8. Dennis, David H., and Cunningham, Bernard E.: Forces and Moments on Pointed and Blunt-Nosed Bodies of Revolution at Mach Numbers from 2.75 to 5.00. NACA RM A52E22, 1952.
9. Eggers, A. J., Jr., and Nothwang, George J.: The Ames 10- by 14-Inch Supersonic Wind Tunnel. NACA TN 3095, 1954.
10. Monaghan, R. J.: An Approximate Solution of the Compressible Laminar Boundary Layer on a Flat Plate. R.A.E. TN Aero. 2025, Sup. 96, 1949.

Z

NACA RM A54B15

CONFIDENTIAL

17

A-18608



(a) Photograph of models.

Figure 1.- Models tested.

CONFIDENTIAL

Volume = .789 cu in.

$f = 3$

Volume = .943 cu in.

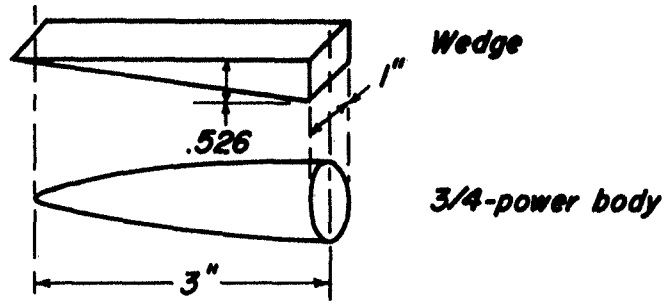

Volume = 1.30 cu in.

$f = 5$

Volume = 1.57 cu in.

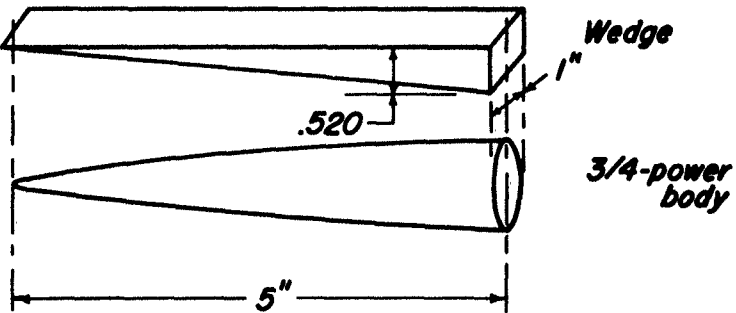

Volume = 1.88 cu in.

$f = 7$

Volume = 2.20 cu in.

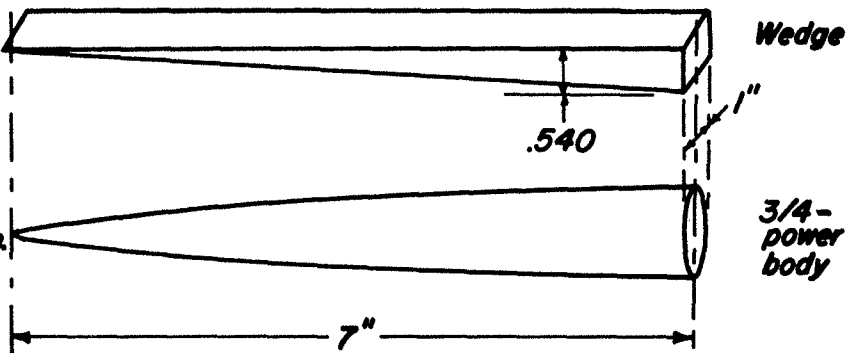

(b) Dimensions of models.

Figure 1.- Concluded.

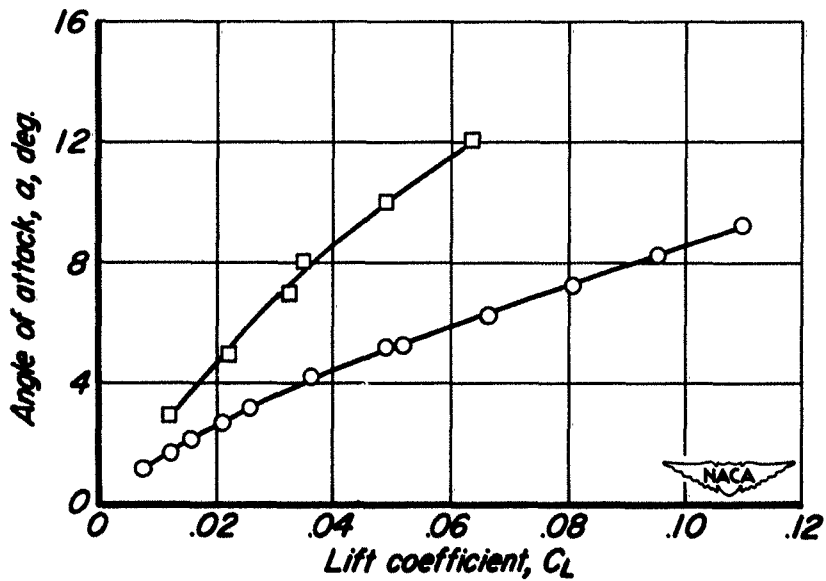
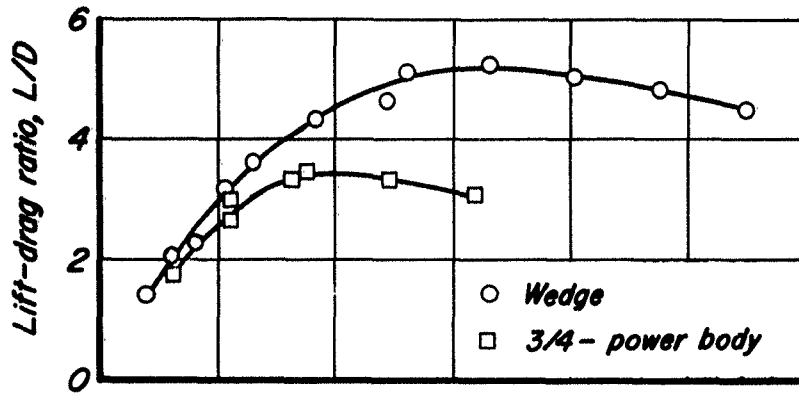

Figure 2.- Comparison of lift-drag curves, drag curves, and lift curves of bodies with fineness ratio 7.

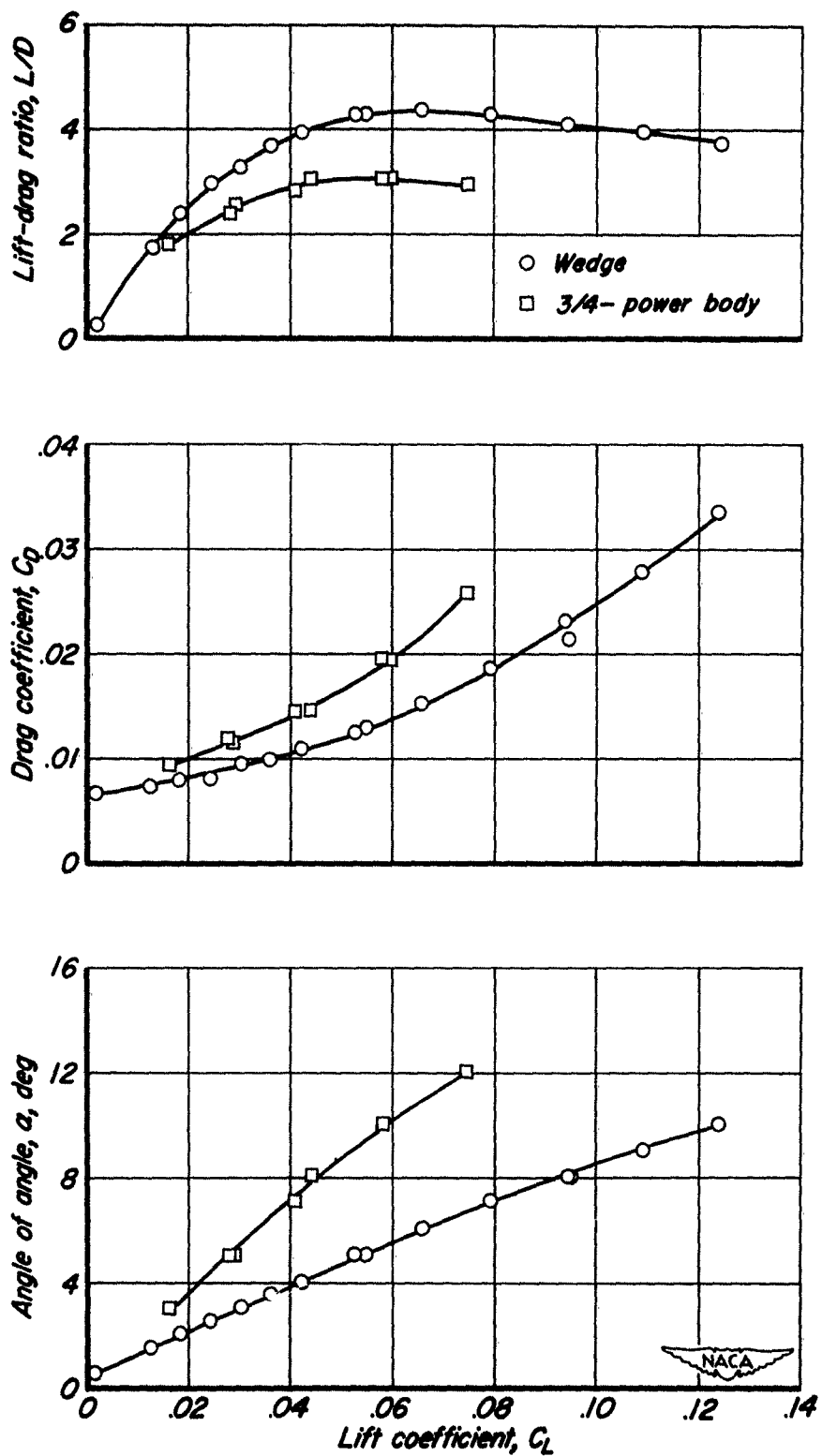

Figure 3.— Comparison of lift-drag curves, drag curves, and lift curves of bodies with fineness ratio 5.

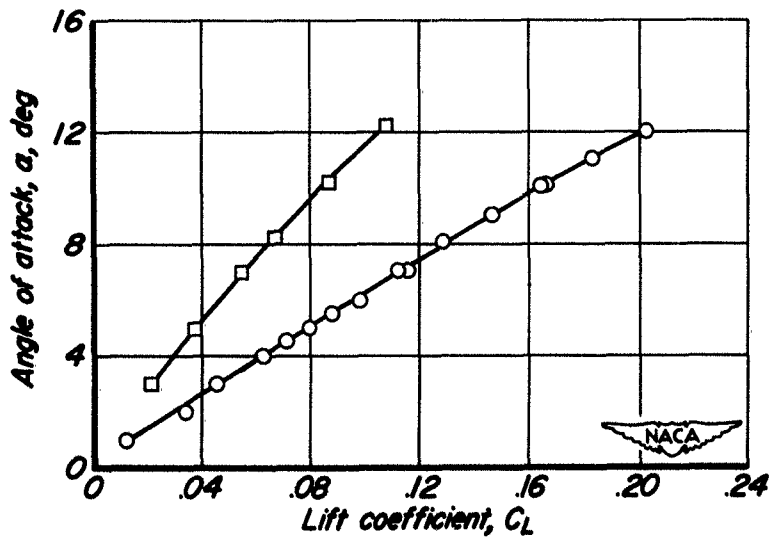
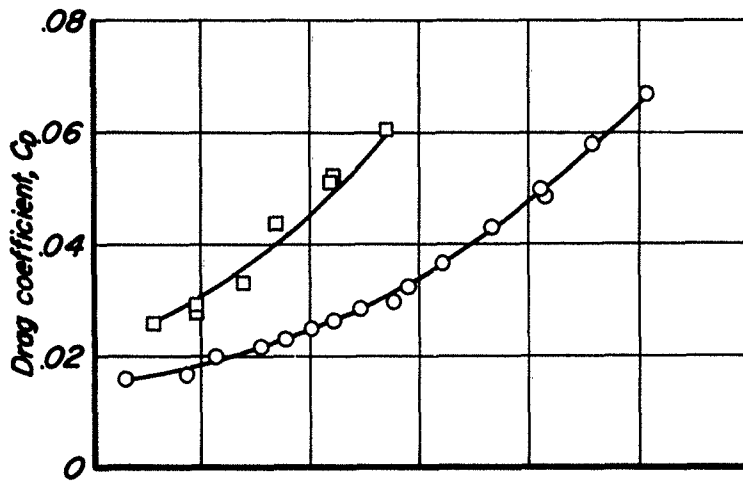
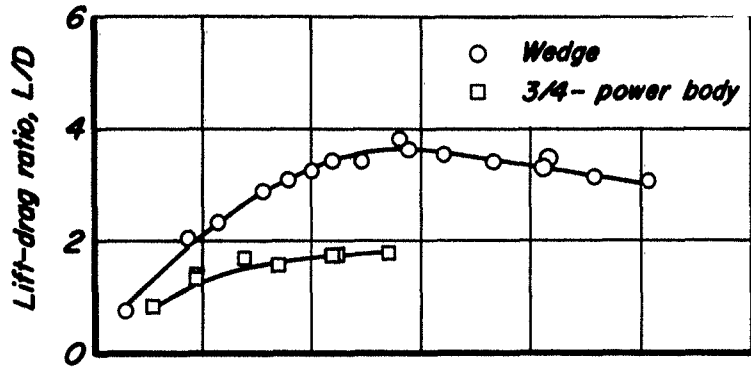

Figure 4.- Comparison of lift-drag curves, drag curves, and lift curves, of bodies with fineness ratio 3.

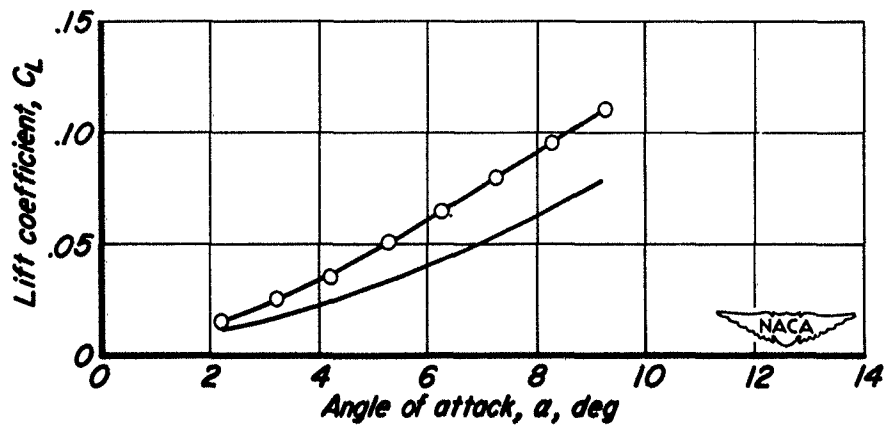
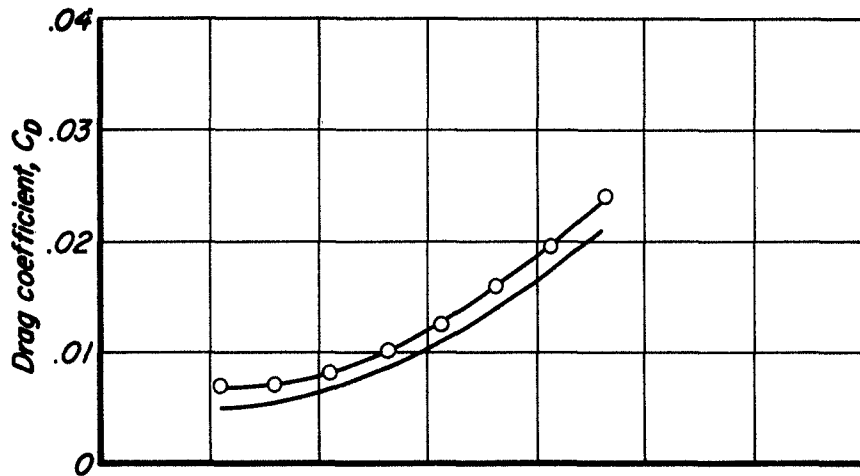
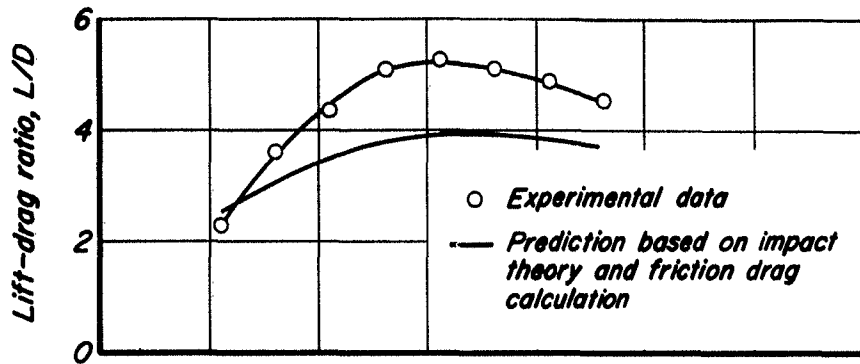

Figure 5.— Comparison of impact theory and skin-friction prediction with experimental lift-drag, drag, and lift curves for the wedge of fineness ratio 7.

NACA RM A54B15
National Advisory Committee for Aeronautics.
OPTIMUM LIFTING BODIES AT HIGH SUPERSONIC
AIRSPEEDS. Meyer M. Resnikoff. May 1954. 22p.
diagrams, photo. (NACA RM A54B15) CONFIDENTIAL

Optimum lifting bodies at high supersonic airspeeds
are determined with the aid of Newtonian impact
theory. Simple wedges are found to fall in the cate-
gory of such bodies. Results of tests at a Mach num-
ber of 5 of several wedges and corresponding bodies
of revolution having fineness ratios from 3 to 7 show
that the wedges have up to 100-percent-higher lift-
drag ratios.

Copies obtainable from NACA, Washington

NACA RM A54B15
National Advisory Committee for Aeronautics.
OPTIMUM LIFTING BODIES AT HIGH SUPERSONIC
AIRSPEEDS. Meyer M. Resnikoff. May 1954. 22p.
diagrams, photo. (NACA RM A54B15) CONFIDENTIAL

Optimum lifting bodies at high supersonic airspeeds
are determined with the aid of Newtonian impact
theory. Simple wedges are found to fall in the cate-
gory of such bodies. Results of tests at a Mach num-
ber of 5 of several wedges and corresponding bodies
of revolution having fineness ratios from 3 to 7 show
that the wedges have up to 100-percent-higher lift-
drag ratios.

Copies obtainable from NACA, Washington

CONFIDENTIAL

1. Flow, Supersonic (1.1.2.3)
 2. Bodies - Shape Variables (1.3.2)
 3. Bodies - Cross Section (1.3.2.2)
 4. Bodies - Thickness Dis-tribution (1.3.2.3)
- I. Resnikoff, Meyer M.
II. NACA RM A54B15



CONFIDENTIAL

CONFIDENTIAL

1. Flow, Supersonic (1.1.2.3)
 2. Bodies - Shape Variables (1.3.2)
 3. Bodies - Cross Section (1.3.2.2)
 4. Bodies - Thickness Dis-tribution (1.3.2.3)
- I. Resnikoff, Meyer M.
II. NACA RM A54B15



CONFIDENTIAL

NACA RM A54B15
National Advisory Committee for Aeronautics.
OPTIMUM LIFTING BODIES AT HIGH SUPERSONIC
AIRSPEEDS. Meyer M. Resnikoff. May 1954. 22p.
diagrams, photo. (NACA RM A54B15) CONFIDENTIAL

Optimum lifting bodies at high supersonic airspeeds
are determined with the aid of Newtonian impact
theory. Simple wedges are found to fall in the cate-
gory of such bodies. Results of tests at a Mach num-
ber of 5 of several wedges and corresponding bodies
of revolution having fineness ratios from 3 to 7 show
that the wedges have up to 100-percent-higher lift-
drag ratios.

Copies obtainable from NACA, Washington

NACA RM A54B15
National Advisory Committee for Aeronautics.
OPTIMUM LIFTING BODIES AT HIGH SUPERSONIC
AIRSPEEDS. Meyer M. Resnikoff. May 1954. 22p.
diagrams, photo. (NACA RM A54B15) CONFIDENTIAL

Optimum lifting bodies at high supersonic airspeeds
are determined with the aid of Newtonian impact
theory. Simple wedges are found to fall in the cate-
gory of such bodies. Results of tests at a Mach num-
ber of 5 of several wedges and corresponding bodies
of revolution having fineness ratios from 3 to 7 show
that the wedges have up to 100-percent-higher lift-
drag ratios.

Copies obtainable from NACA, Washington

CONFIDENTIAL

1. Flow, Supersonic (1.1.2.3)
 2. Bodies - Shape Variables (1.3.2)
 3. Bodies - Cross Section (1.3.2.2)
 4. Bodies - Thickness Dis-tribution (1.3.2.3)
- I. Resnikoff, Meyer M.
II. NACA RM A54B15







CONFIDENTIAL

CONFIDENTIAL

1. Flow, Supersonic (1.1.2.3)
 2. Bodies - Shape Variables (1.3.2)
 3. Bodies - Cross Section (1.3.2.2)
 4. Bodies - Thickness Dis-tribution (1.3.2.3)
- I. Resnikoff, Meyer M.
II. NACA RM A54B15



CONFIDENTIAL

<p>NACA RM A54B15 National Advisory Committee for Aeronautics. OPTIMUM LIFTING BODIES AT HIGH SUPERSONIC AIRSPEEDS. Meyer M. Resnikoff. May 1954. 22p. diags., photo. (NACA RM A54B15) CONFIDENTIAL</p> <p>Optimum lifting bodies at high supersonic airspeeds are determined with the aid of Newtonian impact theory. Simple wedges are found to fall in the category of such bodies. Results of tests at a Mach number of 5 of several wedges and corresponding bodies of revolution having fineness ratios from 3 to 7 show that the wedges have up to 100-percent-higher lift-drag ratios.</p>	<p>NACA RM A54B15 National Advisory Committee for Aeronautics. OPTIMUM LIFTING BODIES AT HIGH SUPERSONIC AIRSPEEDS. Meyer M. Resnikoff. May 1954. 22p. diags., photo. (NACA RM A54B15) CONFIDENTIAL</p> <p>Optimum lifting bodies at high supersonic airspeeds are determined with the aid of Newtonian impact theory. Simple wedges are found to fall in the category of such bodies. Results of tests at a Mach number of 5 of several wedges and corresponding bodies of revolution having fineness ratios from 3 to 7 show that the wedges have up to 100-percent-higher lift-drag ratios.</p>	<p>CONFIDENTIAL</p> <ol style="list-style-type: none"> 1. Flow, Supersonic (1.1.2.3) 2. Bodies - Shape Variables (1.3.2) 3. Bodies - Cross Section (1.3.2.2) 4. Bodies - Thickness Distribution (1.3.2.3) <p>I. Resnikoff, Meyer M. II. NACA RM A54B15</p> <p style="text-align: center;"> CONFIDENTIAL</p>
<p>CONFIDENTIAL</p> <ol style="list-style-type: none"> 1. Flow, Supersonic (1.1.2.3) 2. Bodies - Shape Variables (1.3.2) 3. Bodies - Cross Section (1.3.2.2) 4. Bodies - Thickness Distribution (1.3.2.3) <p>I. Resnikoff, Meyer M. II. NACA RM A54B15</p> <p style="text-align: center;"> CONFIDENTIAL</p>	<p>NACA RM A54B15 National Advisory Committee for Aeronautics. OPTIMUM LIFTING BODIES AT HIGH SUPERSONIC AIRSPEEDS. Meyer M. Resnikoff. May 1954. 22p. diags., photo. (NACA RM A54B15) CONFIDENTIAL</p> <p>Optimum lifting bodies at high supersonic airspeeds are determined with the aid of Newtonian impact theory. Simple wedges are found to fall in the category of such bodies. Results of tests at a Mach number of 5 of several wedges and corresponding bodies of revolution having fineness ratios from 3 to 7 show that the wedges have up to 100-percent-higher lift-drag ratios.</p>	<p>CONFIDENTIAL</p> <ol style="list-style-type: none"> 1. Flow, Supersonic (1.1.2.3) 2. Bodies - Shape Variables (1.3.2) 3. Bodies - Cross Section (1.3.2.2) 4. Bodies - Thickness Distribution (1.3.2.3) <p>I. Resnikoff, Meyer M. II. NACA RM A54B15</p> <p style="text-align: center;"> CONFIDENTIAL</p>
<p>CONFIDENTIAL</p> <ol style="list-style-type: none"> 1. Flow, Supersonic (1.1.2.3) 2. Bodies - Shape Variables (1.3.2) 3. Bodies - Cross Section (1.3.2.2) 4. Bodies - Thickness Distribution (1.3.2.3) <p>I. Resnikoff, Meyer M. II. NACA RM A54B15</p> <p style="text-align: center;"> CONFIDENTIAL</p>	<p>NACA RM A54B15 National Advisory Committee for Aeronautics. OPTIMUM LIFTING BODIES AT HIGH SUPERSONIC AIRSPEEDS. Meyer M. Resnikoff. May 1954. 22p. diags., photo. (NACA RM A54B15) CONFIDENTIAL</p> <p>Optimum lifting bodies at high supersonic airspeeds are determined with the aid of Newtonian impact theory. Simple wedges are found to fall in the category of such bodies. Results of tests at a Mach number of 5 of several wedges and corresponding bodies of revolution having fineness ratios from 3 to 7 show that the wedges have up to 100-percent-higher lift-drag ratios.</p>	<p>CONFIDENTIAL</p> <ol style="list-style-type: none"> 1. Flow, Supersonic (1.1.2.3) 2. Bodies - Shape Variables (1.3.2) 3. Bodies - Cross Section (1.3.2.2) 4. Bodies - Thickness Distribution (1.3.2.3) <p>I. Resnikoff, Meyer M. II. NACA RM A54B15</p> <p style="text-align: center;"> CONFIDENTIAL</p>

Copies obtainable from NACA, Washington

Copies obtainable from NACA, Washington

Copies obtainable from NACA, Washington

Copies obtainable from NACA, Washington