

UNCLASSIFIED

AD NUMBER

AD031652

CLASSIFICATION CHANGES

TO: unclassified

FROM: confidential

LIMITATION CHANGES

TO:
Approved for public release, distribution unlimited

FROM:
Distribution authorized to U.S. Gov't. agencies and their contractors; Administrative/Operational Use; DEC 1953. Other requests shall be referred to Office of Naval Research, Arlington VA 22217.

AUTHORITY

ONR ltr, 28 Jul 1977; ONR ltr, 28 Jul 1977

THIS PAGE IS UNCLASSIFIED

UNCLASSIFIED

AD NUMBER
AD031652
CLASSIFICATION CHANGES
TO
confidential
FROM
secret
AUTHORITY
31 Dec 1965, DoDD 5200.10

THIS PAGE IS UNCLASSIFIED

med Services Technical Information Agency

AD

31652

NOTE: WHEN GOVERNMENT OR OTHER DRAWINGS, SPECIFICATIONS OR OTHER DATA ARE USED FOR ANY PURPOSE OTHER THAN IN CONNECTION WITH A DEFINITELY RELATED GOVERNMENT PROCUREMENT OPERATION, THE U. S. GOVERNMENT THEREBY INCURS NO RESPONSIBILITY, NOR ANY OBLIGATION WHATSOEVER; AND THE FACT THAT THE GOVERNMENT MAY HAVE FORMULATED, FURNISHED, OR IN ANY WAY SUPPLIED THE SAID DRAWINGS, SPECIFICATIONS, OR OTHER DATA IS NOT TO BE REGARDED BY ANY PERSON OR CORPORATION, OR OTHERWISE AS IN ANY MANNER LICENSING THE HOLDER OR ANY OTHER PERSON OR CORPORATION, OR CONVEYING ANY RIGHTS OR PERMISSION TO MANUFACTURE, REPRODUCE, OR SELL ANY PATENTED INVENTION THAT MAY IN ANY WAY BE RELATED THERETO.

Reproduced by
DOCUMENT SERVICE CENTER
KNOTT BUILDING, DAYTON, 2, OHIO

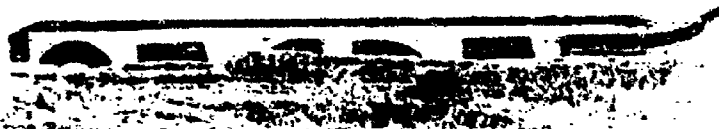

**NOTICE: THIS DOCUMENT CONTAINS INFORMATION AFFECTING THE
NATIONAL DEFENSE OF THE UNITED STATES WITHIN THE MEANING
OF THE ESPIONAGE LAWS, TITLE 18, U.S.C., SECTIONS 793 and 794.
THE TRANSMISSION OR THE REVELATION OF ITS CONTENTS IN
ANY MANNER TO AN UNAUTHORIZED PERSON IS PROHIBITED BY LAW.**

Copy No. 9 of 48

This report consists of ~~10~~
10 preliminary pages
and 94 pages of text.

Report No. 126-3

**A STUDY
OF
HYDRODUGT-WEAPON SYSTEMS**

Prepared for

**Office of Naval Research
and
Bureau of Ordnance**

under

Contract No. Nonr-1172(00)

**COLEMAN ENGINEERING COMPANY, INC.
6040 West Jefferson Boulevard
Los Angeles 16, California**

14 December 1953

A-4071

SECURITY NOTICE

This document contains information affecting the national defense of the United States within the meaning of the Espionage Laws, Title 18, U.S.C., Sections 793 and 794. The transmission or the revelation of its contents in any manner to an unauthorized person is prohibited by law.

REPRODUCTION NOTICE

Reproduction of this document in whole or in part is prohibited except with permission of the Chief of Naval Research. The Armed Services Technical Information Agency is authorized to make reproduction and numbered distribution in local series when notification of additional distribution is furnished the Chief of Naval Research (Code 463).

This document has been reviewed in accordance with OPNAVINST 5510.17, paragraph 5. The security classification assigned hereto is correct.

Date: 1/25/54 Col. E. S. Johnson
By direction of
Chief of Naval Research (Code 463)

DISTRIBUTION LIST

<u>Addresses</u>	<u>No. of Copies</u>
Chief of Naval Research (Code 419) Department of the Navy Washington 25, D.C.	1
Chief of Naval Research (Code 429) Department of the Navy Washington 25, D.C.	1
Chief of Naval Research (Code 463) Department of the Navy Washington 25, D.C.	10
Chief of Naval Research (Code 466) Department of the Navy Washington 25, D.C.	1
Chief, Bureau of Ordnance (Re 2) Department of the Navy Washington 25, D.C.	1
Chief, Bureau of Ordnance (Re 3) Department of the Navy Washington 25, D.C.	1
Chief, Bureau of Ordnance (Re 6) Department of the Navy Washington 25, D.C.	1
Chief, Bureau of Ordnance (Re 8) Department of the Navy Washington 25, D.C.	1
Officer in Charge U.S. Naval Ordnance Test Station - Pasadena Annex Thompson Laboratories Pasadena, California	2
Commander U.S. Naval Ordnance Test Station, Inyokern - China Lake, California	3

<u>Addresses</u>	<u>No. of Copies</u>
Commanding Officer U.S. Naval Underwater Ordnance Station Newport, Rhode Island	1
Commander Naval Ordnance Laboratory White Oak, Silver Spring 19, Maryland	1
Director (Code 2000) Naval Research Laboratory Washington 25, D.C.	1
Bureau of Aeronautics Representative 15 South Raymond Street Pasadena 1, California	1
Chief of Naval Operations (Op-346) Department of the Navy Washington 25, D.C.	1
Chief of Naval Operations (Op-374) Department of the Navy Washington 25, D.C.	1
Executive Secretary Committee on Undersea Warfare National Research Council 2101 Constitution Avenue, N. W. Washington, D. C. Via: Contract Administrator, South Eastern Area Office of Naval Research 2110 G Street, N. W. Washington 7, D. C.	1
British Joint Services Mission Washington 25, D. C. Via: Chief of Naval Operations (Op-321k) Department of the Navy Washington 25, D. C.	3
Commanding Officer Office of Naval Research Navy #100 Fleet Post Office New York, New York	1

Addresses

No. of Copies

Commanding Officer
Office of Naval Research Branch Office
1030 East Green Street
Pasadena 1, California

1

Commanding Officer
Office of Naval Research Branch Office
John Crerar Library Building
86 East Randolph Street
Chicago 1, Illinois

1

Commanding Officer
Office of Naval Research Branch Office
346 Broadway
New York 13, New York

1

Commanding Officer
Office of Naval Research Branch Office
1000 Geary Street
San Francisco 9, California

1

FOREWORD

Under the provisions of Contract No. N6nr-1172(00), Coleman Engineering Company, Inc., conducted a generalized study of the Aerojet-General Corporation's Hydrodact missile, its performance, and its capabilities as an underwater weapon. The work was carried out during the period 15 March 1953 to 14 December 1953 for the Office of Naval Research and the Bureau of Ordnance. This report presents the results and findings of the study, and its submittal represents completion of the contract as amended by Amendment No. 1 thereto.

TABLE OF CONTENTS

	<u>Page</u>
SECTION I - GENERAL:	
A. Introduction	1
B. Purpose of the Study	2
C. Resume of Study Activity	3
D. Summary	5
SECTION II - DISCUSSION-	
A. Description of the Hydroduct Missile	8
B. Advantages and Disadvantages	14
C. Development of Hydroduct Weapon Systems	16
D. Potential Applications	20
E. Fire-Control Considerations	29
F. Launching Considerations	33
SECTION III - HYDRODYNAMICS AND BALLISTICS	
A. General	37
B. Initial Conditions	39
C. Tip-Off	42
D. Dynamic Characteristics	43
E. Deviations	46
F. Dispersion	56
G. Cavitation	58
H. Mutual Interference	61

SECTION IV - WEAPON SYSTEM EFFECTIVENESS

A. General 62

B. Effects of Dispersion and System Errors 63

REFERENCES 72

BIBLIOGRAPHY 74

**APPENDIX I - Initial Angle of Attack and Flight Path Angle
with Rectilinear Motion of Launching Vehicle** 76

APPENDIX II - Equations of Motion 78

APPENDIX III - Numerical Values 87

APPENDIX IV - Approximate Trajectory Equations 89

APPENDIX V - Deceleration 91

APPENDIX VI - Tip-Off 92

LIST OF ILLUSTRATIONS

<u>Fig.</u>	<u>Legend</u>	<u>Page</u>
1	Schematic Sketch of Hydroduct Missile	11
2	Thrust Required and Available - 9-inch Hydroduct	12
3	Predicted Performance - 9-inch Hydroduct	13
4	Schematic Range Comparisons of Weapon "A" to Hydroduct and Hydrocutter	27
5	Schematic "Dead Time" Comparisons of Weapon "A" to Hydroduct and Assumed Hydrocutter for Various Horizontal Ranges, Showing Effects of Target Depth	28
6	Angle of Yaw Due to Cross Stream Launching	41
7	Transients in Angle of Attack and Flight Path Angle	45
8	Approximate Vertical Trajectories - Effect of Cross Stream and Tip-Off	49
9	Approximate Vertical Trajectories - Effect of Cross Stream and Tip-Off	50
10	Approximate Vertical Trajectories - Effect of Launching Submarine Manuevering in Pitch	51
11	Examples of Estimated Vertical Deviation	52
12	Estimated Maximum Usable Range	53
13	Approximate Lateral Trajectories Corrected for Cross Current and Tip-Off Effects (Launching Submarine Velocity - 20 fps)	54
14	Estimated Deviation in Lateral Trajectory due to Cross Stream Launching	55
15	Estimated Variation in Cavitation Coefficient for Incipient Cavitation with Angle of Attack or Yaw	59
16	Estimated Cavitation Limits	60

<u>Fig.</u>	<u>Legend</u>	<u>Page</u>
17	Variation in Single-Shot Hit Probability with Bias + Beam Attack.	66
18	Variation in Single-Shot Hit Probability with Target Aspect and Bias.	67
19	Variation in Hit Probability with Salvo Size and Bias.	68
20	Variation in Hit Probability with Random Error and Bias, Salvo of Five Hydroducts	69
21	Variation in Hit Probability with Target Aspect and Bias, Salvo of Five Hydroducts	70
22	Variation in Hit Probability with Dispersion and System Errors.	71

S

SECTION I.

GENERAL

<u>Part</u>		<u>Page</u>
A.	Introduction.	1
B.	Purpose of the Study.	2
C.	Resume of Study Activity.	3
D.	Summary.	5

A. INTRODUCTION

Presented in this report are the results of a broad and generalized study of the Aerojet-General Corporation's "Hydroduct" missile. This work was undertaken in March 1953 for the Office of Naval Research and the Bureau of Ordnance, and was completed in December 1953.

Briefly, the Hydroduct is a high speed, underwater missile operating in the manner of an unguided rocket. It was developed specifically for underwater operation and utilizes the conversion of intake sea water to steam by the heat of reaction of a burning propellant known as "Alcio", a mixture of powdered aluminum and potassium perchlorate. It is propelled by a high velocity "vapor-jet" consisting of the steam and the products of combustion, the former being fully condensible and the latter dispersed as minute solid particles. Current versions of the Hydroduct are designed for speeds as high as 150 knots without cavitation at depths greater than 50 feet, and as a result ballistic dispersion is ostensibly low. Although its present power plant configuration is inoperable at depths greater than 300 feet, a modified version now under development, known as the "Hydroductor", is considered capable of operation to depths of 1000 feet or more.

Although no operational versions have been fabricated as yet, a 4.5-inch diameter test vehicle has undergone tests at both the San Clemente Island test facility and the Morris Dam Torpedo Range. Two operational versions have been proposed for ASW use. One of these is designed to carry a 35-pound contact-fused warhead, with a minimum powered range of 1000 yards. This version is nine inches in diameter, 72 inches in length, and has an approximate weight in air of 215 pounds. The other version is scaled slightly larger, with a maximum diameter of 10 inches, to accommodate a 50-pound warhead.

The missile itself is extremely simple in both principle and design, has no moving parts, and relies on no instruments in its flight. It is, however, inoperable without sufficient ram pressure to enable the flow of inlet water into the combustion chamber, and therefore requires initial boost before free flight can be sustained.

A more detailed description of the Hydroduct and its performance is given later in the report.

B. PURPOSE OF THE STUDY

Objectively, the study was in part a generalized investigation of the basic problems of developing and utilizing complete Hydroduct weapon systems. Its principle object, however, was examination of the missile itself, its performance and ballistic behavior, and investigation of certain hydrodynamic aspects of the ballistic problems. The effects of cross currents and tip-off were of particular interest because it was thought possible that a serious degradation of performance might be caused thereby, and since such effects were not experienced under controlled test conditions an analytical investigation was desired.

While the principle emphasis of the study was placed on the performance of the missile itself, an effort was made to examine the over-all aspects of complete weapon systems and certain operational problems involved. This portion of the study was limited in extent and sought only to investigate some of the fundamental problems and basic considerations. It should be pointed out that the study was not intended to be an "evaluation" of the Hydroduct, nor an attempt to prove or disprove the feasibility of any application. It was not of sufficient scope or extent for such purposes. While the results clearly pertain to the questions of feasibility and may be helpful in appraising the weapon's potential worth, it should be apparent that considerable appended effort would be required before an evaluation of the effectiveness of complete Hydroduct weapon systems could be made.

C. RESUME OF STUDY ACTIVITY

Work commenced in April 1953 with a general examination of the Hydroduct missile, and a review of its development history. The period from April to July was spent primarily in general study of reference material and definition of problems associated with use of such a weapon. During July, visits were made to a number of agencies, both government and private, for discussions of problems associated with the Hydroduct and its possible applications. These visits included the following:

Bureau of Ordnance
Evaluation and Analysis Group
Washington, D. C.

Office of Naval Research
Armament Branch
Washington, D. C.

Bureau of Ordnance
Underwater Ordnance Fire Control
Washington, D. C.

Ordnance Research Laboratory
Pennsylvania State College
State College, Pennsylvania

Bureau of Ships
Submarine Sonar Design Section
Washington, D. C.

Naval Ordnance Test Station
Thompson Laboratories
Pasadena, California

California Institute of Technology
Pasadena, California

Naval Research Laboratory
Special Devices Section
Washington, D. C.

David Taylor Model Basin
Washington, D. C.

Stevens Institute of Technology
Hoboken, New Jersey

Office of Chief of Naval Operations
Washington, D. C.

Submarine Development Group 2
New London, Connecticut

Office of Chief of Naval Operations
Operations Evaluation Group
Washington, D. C.

U.S. Navy Underwater Sound Lab.
New London, Connecticut

The purpose of these visits was to obtain information, data, and reference material on the following subjects:

Hydrodynamic data applicable to the Hydroduct missile.

Characteristics of sonar and other gear associated with target detection, tracking, and fire control.

The characteristics and performance, particularly maneuverability, of submarines.

SECRET

Vulnerability of submarines and possible surface vessel targets.

Tactical situations in pro- and antisubmarine warfare in which short range, high speed, unguided missiles of the Hydroduct type might prove to be an effective weapon.

Characteristics, capabilities, and limitations of torpedoes and other underwater weapons.

Possible "secondary" uses of Hydroduct missiles such as anti-submarine use, harbor defense, etc.

Much of the information sought was intended as background material to assist in further definition of Hydroduct-system problems. The comments, opinions, and suggestions of personnel contacted were very helpful and a considerable amount of reference material was recommended, which the Office of Naval Research thereafter sought to obtain for the study's use. Although time and availability did not permit receipt of all material recommended, a considerable amount was obtained and reviewed to the extent permitted by the time remaining.

SECRET

D. SUMMARY

The examination undertaken in this study of the hydrodynamic and ballistic properties of the Hydroduct, and of possible degrading effects in actual operational conditions as opposed to the "ideal" conditions of controlled test programs, does not indicate that the missile's performance would suffer a serious degradation. The disturbing effects of cross currents and tip-off at launching produce deviations of the missile's flight path which are predictable in direction and magnitude. The dynamic characteristics of the Hydroduct tend to minimize the effects of these disturbances, and a wide range of operating conditions would be available with minimum correction of bias due to cross stream and tip-off. However, under certain circumstances of vehicle and launcher motion, the effects of such deviations, if not compensated, could appreciably reduce hit probabilities, and under such conditions the fire control system should be equipped to provide the necessary compensation in computing the desired aiming point.

The possibility of random factors being introduced by these effects, such that compensation could not be made in fire control and aim, is the real basis for concern. Although there is a degree of uncertainty in this regard that cannot be resolved by analytical study alone, no theoretical reasons for expectation of increased dispersion due to either cross currents or tip-off at launching have been found in this study, and it appears a reasonable conclusion that such uncertainty is of relatively minor consequence to the weapon's probable operational performance and effectiveness. Mutual interaction effects between two or more missiles fired in close proximity to one another might introduce random effects, but ripple fire in place of actual salvos should reduce such effects to negligible levels without having appreciable influence on hit probabilities.

The missile's characteristics appear to make it inherently capable of highly accurate flight, and limited tests of the 4.5-inch test version tend to verify this belief. While a sufficient number of tests has not been made as yet for precise statistical determination of ballistic dispersion, the tests indicate definite promise of low dispersion, and values as low as 10 mils laterally and perhaps no more than 15 mils vertically appear to be reasonable possibilities, especially considering the expectation of further improvement over the past and present test versions.

It is the general conclusion of this study that the Hydroduct missile is in itself fundamentally sound, and capable of high performance under actual operational conditions. The major areas of doubt regarding its potential worth as an underwater weapon do not, therefore, appear to lie in the performance of the missile, but in the uncertainties of other components of complete weapon systems and in the effects of these uncertainties on over-all system perform-

ance. As an unguided missile, the Hydroduct must rely on adequate aiming, and as a weapon of limited range its value depends heavily upon the opportunity that exists or can be created for its use. The definition of specific applications and the development of suitable tactics are therefore of fundamental concern for both evaluation of the weapon and for delineation of system requirements.

Given an attacking opportunity, the accuracy with which the missile can be aimed becomes the critical factor in the weapon system's performance. The problem of aiming has two more or less distinct aspects -- the determination of the desired point of aim, which depends upon the sonar and fire control systems, and the accomplishment of that desired aim, which involves the maneuverability and controllability of the firing vehicle and the mechanics of the launching system.

A generalized examination of the over-all aspects of tactical applications, weapon system components, and the principal factors affecting the system performance was conducted and is described in the text of this report. Because of its broad scope, any attempt to summarize that material here would be repetitious, and reference to the text should be made for discussion of the results of that portion of the study.

The body of the report is presented in sections for ease of reference to individual subjects of interest. Section II includes a description of the Hydroduct missile and a general discussion of various considerations and problems believed fundamental to development and synthesis of complete weapon systems. Discussion of possible applications in pro- and antisubmarine warfare and of fire control problems and launching means is included. Section III describes the results of study and analysis of the hydrodynamic and ballistics problems, including the effects of cross currents and tip-off and other possible causes of deviation and ballistic dispersion. Section IV presents a brief discussion and the results of a limited analytical investigation of the possible effects of dispersion and various system errors on weapon system effectiveness. A number of appendices containing mathematical derivations follow the text, these having been separated to avoid redundancy in the discussions.

With regard to recommendations concerning the needs and directions of further efforts to develop and exploit the Hydroduct, much is either expressed or implied throughout the text of the report and need not be repeated in detail here. In general, it appears that continued activity should include further tests of the missile to enable the development of optimum physical configurations and to establish and confirm the magnitudes of dispersion and bias. It is also recommended that future studies of complete Hydroduct weapon systems be planned and undertaken to provide more explicit definition of operational parameters than has been possible within the limited extent of this study. In particular, the fire control problem should be thoroughly investigated, and strong emphasis should be placed on design studies and analyses of launching.

SECRET

mechanisms. Such investigations would be indispensable to a valid evaluation of system performance and reliable determination of hit and kill probabilities. The broader operational analyses of tactics and the effects thereof on system performance should be coordinated with these investigations, and should be considered an integral part of any comprehensive effort to evaluate the potential worth of Hydroduct-weapon systems.

SECRET

SECTION II.

DISCUSSION

<u>Part</u>		<u>Page</u>
A.	Description of the Hydroduct Missile.	8
B.	Advantages and Disadvantages.	14
C.	Development of Hydroduct Weapon Systems.	16
D.	Potential Applications.	20
E.	Fire Control Considerations.	29
F.	Launching Considerations.	33

A. DESCRIPTION OF THE HYDRODUCT MISSILE

A broad program of research and development on underwater propulsive devices, being carried out by the Aerojet-General Corporation for the Office of Naval Research, has included a variety of methods of underwater propulsion. The term "hydroduct" was adopted to identify those systems in which intake water is integrally involved in producing thrust, and "vapor-jet" is used to distinguish jet systems in which water either reacts with a hydrofuel to generate steam or is converted to steam by the heat of a burning "propellant." One such propellant is a stoichiometric mixture of powdered aluminum and potassium perchlorate which, by being compressed into a cylindrical solid form and properly encased, can be caused to burn in the manner of a cigarette at an approximate temperature of 7000°F. The abbreviated term "Alcio" is used in reference to the aluminum-potassium perchlorate mixture.

Despite the broad connotation of the term "hydroduct" as described above, this report considers the "Hydroduct" missile to operate specifically on the combination of Alcio, vapor-jet, and hydroduct principles. Sea water is taken in under ram pressure through a small orifice in the nose, passes through a diffuser and an axial tube in the forward "warhead" section to the center, or "propellant", section where it bypasses the propellant through an annular channel, thus acting as a coolant. It is sprayed on the burning aft face of the Alcio grain, producing a vapor-jet composed of steam and the products of combustion. The aft, or "nose", section contains the combustion chamber. "Mixing" in the combustion chamber is enhanced by "turbulator rings" located forward of the nozzle. The jet is fully condensible, the combustion products being dispersed as minute solid particles, giving the missile the advantages of an essentially wakeless flight. A schematic sketch of the missile is shown on page 11.

The Hydroduct was developed specifically for underwater flight. It is not a rocket in the true sense since it depends on the intake of water under ram pressure to produce thrust, and thus is more analogous to a "ramjet" air missile. In purpose and performance, however, it can be classified a "high speed, unguided, underwater rocket", and thus offers itself for use in applications suitable for such weapons.

In principle and in construction, it is a relatively simple weapon. It employs no moving parts and relies on no instruments in its flight. Its flight is intended to be highly accurate and precision in manufacture is therefore required to minimize geometric misalignments and assure consistent propulsion characteristics. In any form of mass production, however, its simplicity should predominate as a cost factor and Hydroducts are potentially, therefore, low-cost missiles.

SECRET

In an effort to minimize the dispersion, the missile is intended to run "fully wetted." To this end, the "Lyon's Form A" was selected for the body shape to maintain minimum values of negative pressure coefficients. It is estimated that cavitation will not be experienced at depths greater than about 50 feet at maximum equilibrium flight speeds of the missile. Present versions employ a fineness ratio of approximately 9:1. Three fins of semispan slightly greater than the body diameter are relied on for stability and are slightly canted to the longitudinal axis to produce a "slow spin", the purpose of which is to minimize the dispersion due to malalignments. In the absence of cavitation, relatively short fin spans can be used to provide the required stability.

The flight path of the missile is a ballistic type trajectory, the shape of which is dependent upon the relative gravity, buoyancy, thrust, lift, and drag forces involved. Thus, the range is limited both by the burning time of the propellant and by the extent of gravity drop in flight.

Since water intake is required and sufficient ram pressure must exist to enable the intake of water against the chamber pressure, initial boost must be provided in launching. It is contemplated that initial boost capable of imparting a launching velocity somewhat higher than the "equilibrium velocity" of the missile in free flight will be employed. While this imposes a heavy load on the design of the launcher, it materially aids the efforts to minimize dispersions and deviations in the trajectory by eliminating an acceleration period and initial low velocities during free flight.

Current versions of the Hydroduct are considered inoperable at depths greater than 300 feet. In an effort to eliminate this restriction, development of a "steam-injector condenser" has been undertaken. This device is intended to provide water intake ducts and a condensing chamber aft of the jet nozzle such that jet stability could be realized at greater depths. Versions of the missile operating on this principle are referred to as "Hydroductors", and it is estimated that successful operation at depths greater than 1000 feet can be attained.

A small test version of the Hydroduct has been developed for experimental evaluation of the weapon's basic feasibility and its ballistic behavior. The test missile has a 4.5-inch diameter body, is approximately 40 inches long, and has an air weight of 33 pounds. Using approximately nine pounds of Alcio grain, a number of successful firings have been made at the Morris Dam Torpedo Range in which maximum speeds as high as 250 feet per second and ranges of better than 1000 feet have been attained. Following early tests at the San Clemente Island range of the Naval Ordnance Test Station, some 50 firings have been made at Morris Dam. Erratic behavior and other mishaps were experienced with some rounds, but in general the results are favorable and indicate considerable promise of the development of Hydroduct missiles with exceptionally low dispersions, speeds in the order of 150 knots, and usable ranges of 4000 feet or better.

SECRET

The Aerojet-General Corporation has proposed a 9-inch diameter version of the Hydroduct, the essential characteristics of which are:

Body diameter	9 in
Length	72 in
Weight (air)	215 lb
Warhead (Composition B)	35 lb
Warhead fuze	Contact type
Launching velocity (all depths)	250 fps
Maximum equilibrium velocity (free flight, 50-ft depth)	240 fps
Minimum equilibrium velocity (free flight, 300-ft depth)	160 fps
Minimum powered range	1000 yd

The predicted performance of this version is presented graphically in Figs. 2 and 3, pages 12 and 13.

A 10-inch diameter version has also been designed to accommodate a 50-pound warhead, in case the 9-inch version should lack the desired lethality. These particular versions were designed for ASW use, with the intention of providing a weapon capable of rupturing the pressure hull upon contact with the outer hull.

Future tests and development of the missile can be expected to further improve the missile's performance. Optimized fin configurations, spin rates, etc., can be expected to improve consistency of flight and enable minimum dispersions. Development of improved methods for Alclad grain compaction will minimize inconsistencies of burning rate and thrust.

New configurations, versions, and concepts of the Hydroduct are possible by means of further exploiting the Hydroduct's propulsion principles. Depth control and programmed guidance are conceivable possibilities, and "homing" might be possible by the use of "staged" flight, reducing self-noise to tolerable limits in the terminal phase by use of an auxiliary propulsion system. It is not with such future possibilities, however, that the study has been concerned.

SECRET

SECRET

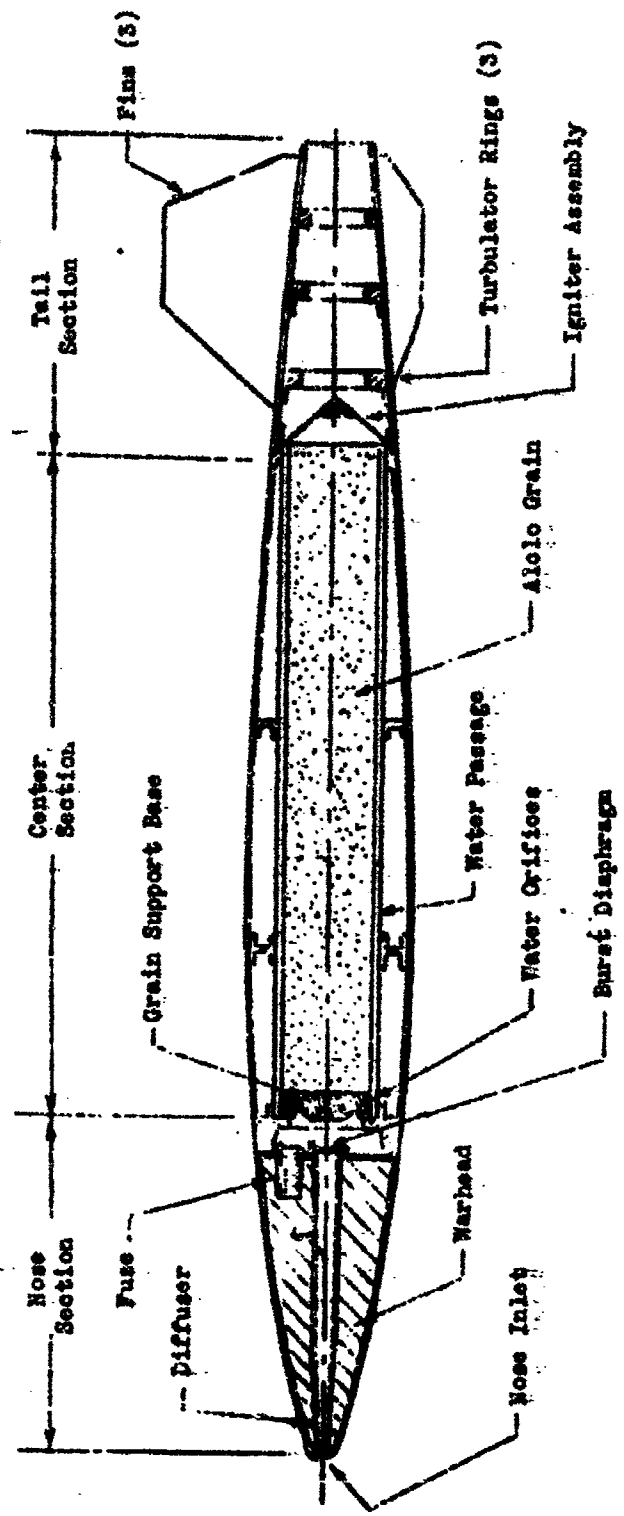

FIGURE 1

SCHEMATIC SKETCH OF HYDROOUT MISSILE

SECRET

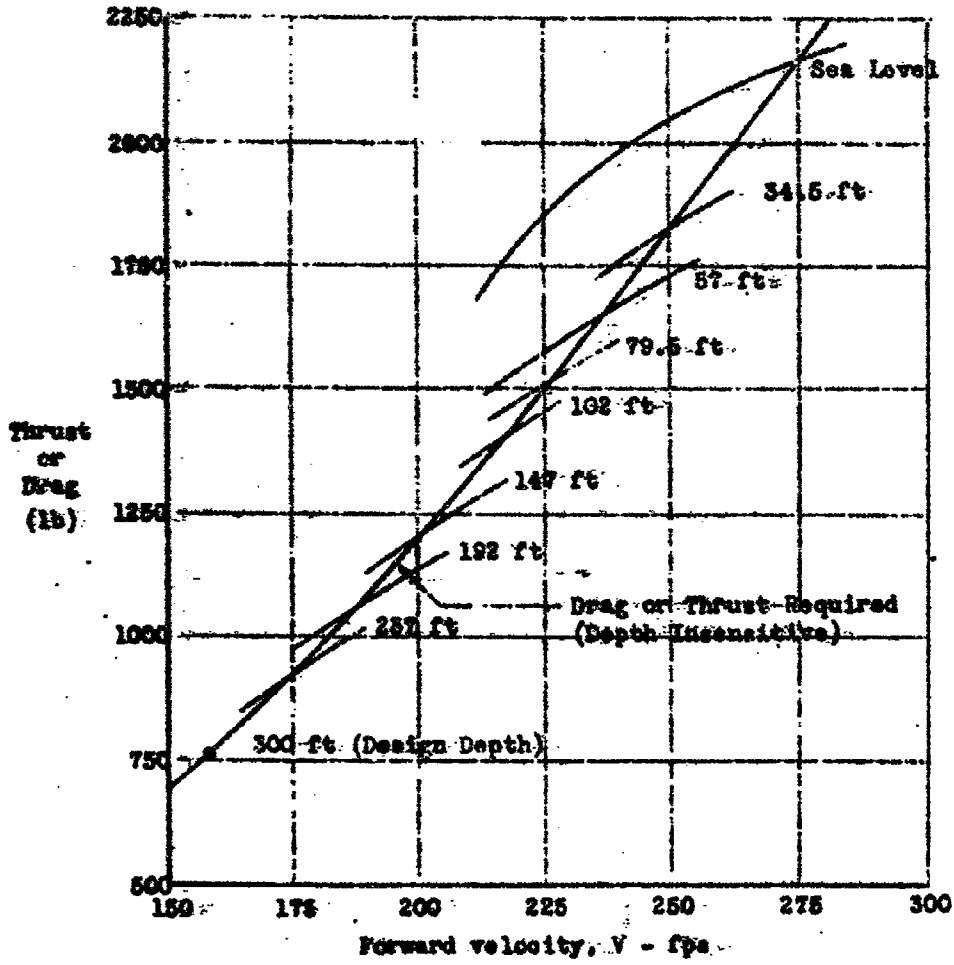

FIG. 2

THRUST REQUIRED AND AVAILABLE - 9-INCH HYDRODUCF

(Reference 4)

SECRET

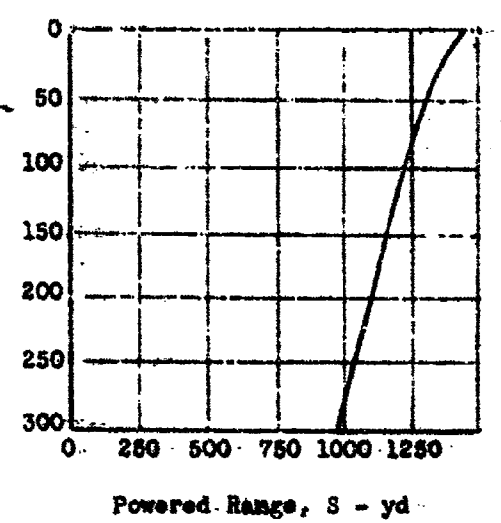
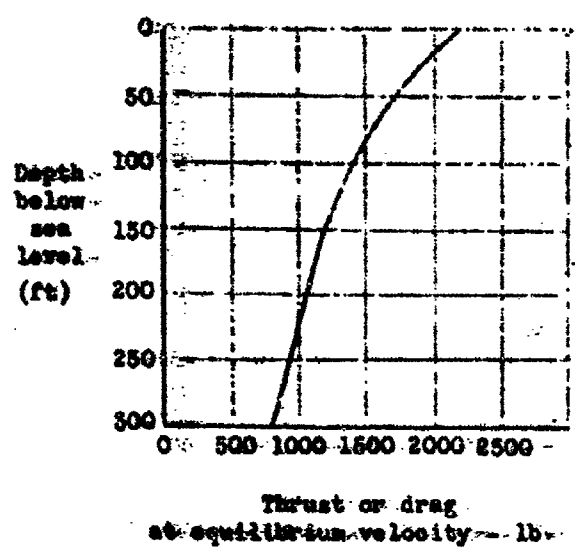
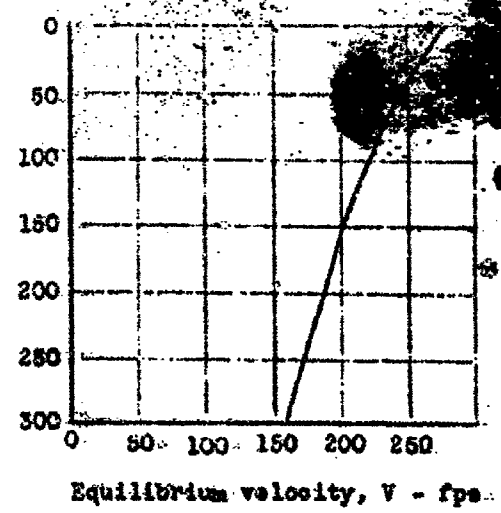
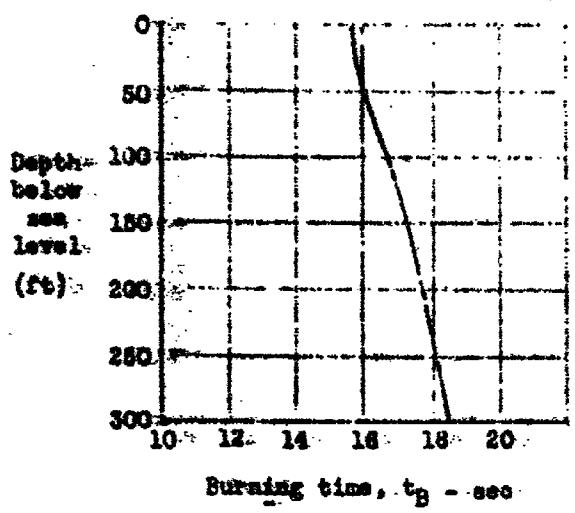

FIG. 3

PREDICTED PERFORMANCE - 9-INCH HYDRODUCT
(Reference 4)

SECRET

B. ADVANTAGES AND DISADVANTAGES

The following characteristics and operating requirements are considered to be the principal advantages and disadvantages of the Hydroduct in its present versions, and the predominant factors to be considered in appraising its capabilities:

1. ADVANTAGES

- a. Probably the outstanding advantage of the Hydroduct is its speed. Its ability to reach a target at 1000 yards range in less than 20 seconds gives it an exceptional advantage over alternate weapons in several respects. "Dead time" is minimized, reducing the target's evasion capabilities. The prediction aspects of the fire control are greatly simplified. Active sonar as a final correction in the fire control can be employed without materially increasing the target's ability to thwart the attack.
- b. The ability to run "fully wetted" considerably improves the missile's accuracy, enabling use of "optimized" pattern control in multiple firings and consequent increase in hit probabilities for a given number of rounds.
- c. Its simple design and operating principles enable the size and payload to be adapted to match target vulnerability. Thus, if designed for use against highly vulnerable targets such as submarines or small surface craft, optimum size and warhead can be provided and the waste of "overkill" avoided.
- d. The missile contains virtually no "wasted" internal space, and is divided into subassemblies such that "high density" storage and ease of handling are greatly facilitated.
- e. The characteristics of the missile suggest the use of small rounds in multiple fire, eliminating the necessity of the "long" minimum arming ranges employed with heavy ordnance as a protection to the firing vehicle.
- f. The simplicity, low cost, and absence of "gadgets" combine to give the Hydroduct reliability, low cost, a potentially high level of producibility and little maintenance should be required.

2. DISADVANTAGES

- a. Its range is limited both by its power endurance and the "fall off" in its trajectory. Eventual improvement over the currently contemplated 1000-yard version is probable, but in its present conception as an

unguided "rocket" it is essentially a "short range" weapon by comparison with other underwater ordnance.

b. The minimum depth for freedom from cavitation is estimated at 50 feet for current versions, and the missile is inoperable below 300 feet. Although cavitation may merely increase dispersion, and periods of air flight are not inconceivable, current versions are intended for subsurface launchings, between these limits, at either surfaced or submerged targets. It should be noted that the "Hydroductor", currently under development, utilizes the basic Hydroduct principles with the addition of a "steam-injector condenser" to achieve depth insensitivity. Successful operation to depths exceeding 1000 feet is anticipated. It should also be noted that cavitation at depths of less than 50 feet could be prevented by slight reduction of speed.

c. Because of its speed and noise level, guidance and homing are probably impracticable, and in the absence of any postfiring corrections, the missile is as good as, and only as good as, the ability to aim it.

d. Although not a disadvantage of the missile itself, realization of the value of low dispersion requires high accuracy of aim, and three-dimensional positioning of the target is required. Currently operational submarine gear does not provide for determination of target depth and elevation angle. Sufficient accuracy of range determination would probably require use of echo-ranging in the fire control.

e. The problem of vertical errors is particularly acute because of the accumulative effects of small vertical-target dimensions, inherently large vertical aiming errors, and susceptibility of the missile to larger vertical dispersions than lateral.

f. The logical compensation for the above-mentioned sources of "vertical error" is a vertical line pattern in either salvo or ripple fire. Thus the "waste" of unsuccessful rounds is introduced, offsetting the previously described advantage of ability to avoid "overkill."

g. The launcher constitutes a "dead weight" to the vehicle, this problem being made more severe by the necessity of heavy initial boost. A "trainable launcher", though advantageous to aiming, would introduce mechanical complexities and further aggravate this problem. The possible effects on the performance and stability of submarine vehicles is a serious consideration.

h. The preservation of low dispersion would require low tolerances and precision techniques in manufacture, and extreme care in shipping and handling to avoid even slight damage, particularly to the fins.

G. DEVELOPMENT OF HYDRODUCT WEAPON SYSTEMS

The concept of unguided, underwater rockets is not new. Germany is known to have attempted the development of such weapons during World War II, and a number of investigations and exploratory test programs have been carried out in this country in recent years. The Naval Ordnance Test Station conducted a series of exploratory underwater tests of rockets at the San Clemente Island range between early 1950 and 1953. Modified versions of HVAR and HPAG rockets were fired underwater, and some tests were made of a specially designed underwater rocket designated SPUR-3-C.

Despite these earlier studies and investigations, underwater rocket development is in its early infancy, and no such weapons are known to have been used or tested in either actual or simulated operations. As a consequence of this and for want of past operational and weapon system studies, the potential applications, utility, and effectiveness of weapons such as the Hydroduct are little more than supposition.

There is little reason to doubt that the Hydroduct offers a practicable underwater rocket for which a high level of performance can be anticipated. By "practicable" it is meant that there are no prohibitive features inherent in the missile itself, such as excessive costs, delicate components, or other serious obstacles to producibility, maintenance, and reliable operation. Examination of the Hydroduct's ballistic behavior and performance characteristics indicates that, within its inherent limitations as an unguided missile of limited range, it promises to provide a weapon of exceptional capabilities. No reasons have been found in the course of this study to doubt the basic feasibility of the missile itself. The test program at the Morris Dam Torpedo Range has proved that its operating principles are basically sound, and has demonstrated its capability of high speed flight without cavitation. Since these tests have been of exploratory nature and have involved a number of configuration changes, there is an insufficient quantity of data for true evaluation of ballistic dispersions. Intuitively, however, it must be concluded that the Hydroduct is fundamentally capable of highly accurate flight, and the ultimate development of optimum configurations might well result in ballistic dispersions as low as 10 mils laterally, and somewhat higher values, but perhaps no more than 15 mils, vertically. Theory alone can neither substantiate nor disprove such claims, and to dwell on the subject would provide little more than academic debate. It is the future tests of optimum configurations that must be relied upon to determine actual levels of dispersion. This study has examined various aspects of the hydro-ballistics problem in search of degrading factors, and has failed to find any regions of serious uncertainty, or sources of degradation that could not be compensated in some reasonable manner. It is the general conclusion of this study, therefore, that the primary areas of uncertainty in attempting to appraise the weapon do not lie in

the performance of the weapon itself, but in two fundamental questions. The first is the question of "opportunity" to use the weapon; the second the question of "ability" to use it. To resolve the former question, it must be shown that its limited range does not preclude sufficient opportunity for its use. The latter is primarily a question of ability to aim the weapon. If sufficient accuracy of aim could not be attained, the potential advantages of the missile's flight accuracy obviously could not be realized. There are other questions, of course -- kill versus survival, countermeasures, costs, producibility, and many other less tangible considerations -- which, although indispensable to a complete evaluation, are more concerned with the weapon's practicality than with its basic feasibility.

While continued development of underwater rocketry would undoubtedly result in eventual improvement over currently conceived versions of the Hydroduct, the indicated performance of these present versions is such that, if the Hydroduct lacks feasible application as a weapon, it is probable that the entire concept of using unguided, underwater rockets is not practical.

During the early phases of this study it became apparent that a wide diversity of opinion exists on the utility of underwater rockets, and on the possible applications for such weapons. It also became apparent that, for the most part, there is little in the way of operational studies or "systems analyses" to support these conflicting viewpoints. The Hydroduct now offers a realistic basis for such studies, and a compelling reason why they should be undertaken. There is no means of eliminating diversity and uncertainty of opinion until applications have been substantiated and the effectiveness of complete weapon systems in such applications evaluated by sound and comprehensive means.

As an unguided, "short" range weapon, the Hydroduct is a contradiction to the emphasis on increasing attack ranges and developing means for compensating the inadequacies of tracking and fire control systems. Long range torpedoes, equipped with guidance and homing systems, are the "ideal" weapons by which the submarine can attack from beyond range of counterdetection, and thus retain its primary advantage of stealth. The Hydroduct has neither guidance nor homing, and its range is considerably less than that of modern torpedoes, but it does have a number of distinct advantages over the torpedo, and, within its limited domain, could prove superior for certain applications. That domain is, of course, the close range attack, and the possible applications include a variety of situations involving a submerged firing vehicle or a submerged target, or both.

There is an expressed need for short range, high speed, underwater missiles for use by submarines within the minimum sensitizing and arming ranges of current torpedoes. The Hydroduct is such a weapon, and its development might be justified on those grounds alone. However, to consider only those situations where no alternate weapon is available as the only possible

use of the Hydroduct overlooks much of its potential. Such an approach to appraising the weapon would limit the opportunity for its use to "inadvertent" close range contacts at less than the "minimum" ranges of other weapons, and this would presume that frequency of such contacts would be the same with the Hydroduct as without. Such a restricted effort to exploit the Hydroduct would certainly impede, and perhaps preclude, its further development. The frequency of such contacts might not be sufficient to substantiate the sacrifices of developing, installing, and operating Hydroduct systems.

The capabilities and performance of the Hydroduct, particularly as an antisubmarine weapon, appear to offer considerably more potential than a stand-by weapon of such restricted opportunity. If it is to be fully exploited, the Hydroduct should be considered not merely as a possible supplement to other ordnance, but as a potential complement of a complete balanced armament system. Any target within its range would present an attacking opportunity regardless of whether or not an alternate weapon could be used. The Hydroduct might be the superior choice, depending on the specific nature of the situation. Although such opportunities might still be the result of "inadvertent" contacts, the frequency might be considerably higher and might be further increased by the effects of the Hydroduct's presence on tactics. Given an effective short range weapon, the short range contact should be less feared. It could, in fact, be sought.

To define and substantiate the maximum "opportunity" for the Hydroduct would involve a combined study of tactics and system performance, and analyses of the effects of each upon the other. Such operational studies and analyses are the ultimate basis for evaluation and synthesis of optimum systems. It is by such studies that maximum "profit" is sought. It is readily apparent that the "profit" of a weapon system is its ability to increase losses of the enemy, or reduce losses to the enemy, to extents exceeding the total costs of its development, installation, and operation. It follows that the fundamental measure of a weapon's effectiveness is its potential of creating such "profit." It should be apparent that probabilities of hit and kill are little more than parameters in the evaluation of a weapon. High probabilities imply, but do not substantiate, actual net gain. Conversely, low probabilities imply, but do not prove, a lack of worth. The actual demarcation between "profit" and "loss" on the kill probability scale cannot be established realistically until the weapon system's "opportunities", as well as its capabilities, have been adequately evaluated.

The problem of evaluating the Hydroduct, then, cannot be resolved simply by analyzing the performance of arbitrary system configurations in assumed tactical applications. The weapon's opportunities must first be defined and substantiated, and their frequencies determined. Only then can a realistic basis exist for the synthesis and optimization of complete weapon systems. This is not meant to imply that rigorous evaluation should be required to justify continued development of Hydroduct systems. To require rigorous

SECRET

proof of feasibility and practicality as prerequisite to undertaking the development of a new weapon system would stifle that development. Rather, it is meant to emphasize the importance of operations analysis as a concurrent part of weapon systems development.

SECRET

D. POTENTIAL APPLICATIONS

1. GENERAL

It is readily apparent that any comprehensive attempt to evaluate the complete realm of possibility for the weapon's use would involve broad and extensive studies, and many complex and intangible considerations. Questions of tactics with the weapon as opposed to tactics without it would be fundamental. The possible future developments in weapons and operational methods of undersea warfare could have considerable bearing, and the techniques and problems of search, detection, tracking, etc., would be basic considerations not only to determining the possible frequency of attacking situations for the Hydroduct, but also the exact nature of those situations. The interrelation between the specific makeup of the attacking situation and the performance required or desired of components of the weapon system such as the fire control, launching means, etc., is clearly of basic concern. Before system requirements can be delineated or system performance evaluated, the specific attacking situations must be adequately defined, since it is these situations and their probable frequencies that determines the performance required of system components. The investigation reported herein was not of sufficient extent to undertake the operational studies required to define and substantiate the weapon's possible applications. The following are therefore based on considerable supposition and are meant to serve as examples of possible cases and to provide a basis for discussion of fire control problems and launcher considerations.

2. SUBMARINE-VS-SUBMARINE

It is generally acknowledged that the antisubmarine submarine, whether the SSK type or any other attack type used for such purpose, suffers a current need for improved weapons. This being a relatively new concept of anti-submarine warfare, the past development of submarine ordnance has not emphasized this need. In considering the possible use of Hydroducts in SS/ASW, the problem can be divided into two separate and distinct cases -- the snorkelling (or surfaced) target submarine, and the completely submerged target submarine. The former provides a known target depth to the attacker; the latter does not.

There is, of course, a wide variety of purposes and attacking situations that could be considered. Use of the Hydroduct as a primary or a secondary weapon, deliberate closure versus inadvertent close range contact, individual versus group tactics, etc., are various considerations each of which could introduce its own unique opportunity for exploiting the Hydroduct. Until a broad course of study of the more complex and intangible possibilities can be made, however, the following "basic" possibilities appear to deserve primary consideration:

a. Submerged Attacker Vs. Snorkelling Target,
Deliberate Closing to Hydroduct Range

The attacking submarine is presumed to be either the "SSK", "Guppy", or other attack type adaptable to ASW, submerged to "optimum" attacking depth at the time the snorkelling target enters attack range. "Optimum" depth is 300 feet unless shallower depths are required to adequately track the target during the approach. Reducing the depth, however, reduces the possible range of attack because of the trajectory "fall off" of the missile. The attacker is assumed operating at "minimum" speed to prevent counter-detection. The target is presumed to be similar to either the German Type XXI or Type XXVI submarine snorkelling at its most probable transit speed.

This situation presumes that the target submarine is not employing echo-ranging during transit as a protection against such an attack. The attacking submarine is thus enabled to track passively, to close to Hydroduct range, and to attempt the most favorable attack position. Once within range, the attack could be delayed to increase the probability of success, since an immediate attack could be made upon detection of countermeasures such as sudden changes in track or speed, or commencement of echo-ranging to confirm any suspicion of the attacker's presence.

This is considered a possible example of primary offensive use of Hydroducts in SS/ASW. Echo-ranging, or perhaps future passive array systems, could enable the transit submarines to prevent such an attack, except perhaps under exceptionally poor sonar conditions. In such cases, however, the attacker's ability to detect and track would also be impeded.

b. Submerged Attacker Vs. Snorkelling Target, -
"Inadvertent" Contact Within Hydroduct Range

The possibility of an inadvertent contact within Hydroduct range between a submerged attacker and a snorkelling target offers a possible "secondary" offensive application for the weapon. Such contacts could result from an unanticipated "chance" contact during extremely poor sonar conditions, or perhaps in the more likely case of a regained contact following a "fade-out" during the approach, use of the "primary" weapon having thus been prevented.

The significant difference between this case and the preceding one, insofar as the "system" and its probability of success are concerned, is that favorable target bearing and aspect are less probable, and the attacker is less likely to be at or near the "optimum" depth. In such an "inadvertent" situation, immediacy is of vital concern, and therefore ability to attain a favorable attack position might be inhibited. A degradation in the quality of system performance, particularly in the fire control, is also to be expected.

c. Submerged Attacker Vs. Submerged Target;
"Inadvertent" Contact Within Hydroduct Range.

This is the submerged-target counterpart of the preceding case, and again presents the increased probability of unfavorable bearing, aspect, and relative depths, and the urgency for immediate attack. Its operational background may be obscure, but its consideration is warranted because of the limited range of detecting the quiet-running, submerged target. The possibilities of such contacts resulting from search in restricted areas such as channels, harbor approaches, etc., seem worthy of consideration. Another possibility could be follow-up search for a lost contact, perhaps as the result of submergence of a previously snorkelling target.

d. Submerged Attacker Vs. Submerged Target;
Deliberate Closing to Hydroduct Range

This is the submerged-target counterpart of the first of the above cases, and a situation in which favorable target bearing and aspect, and optimum relative depths would be sought during the approach. Such an attack might be possible without loss of stealth if the attacker were equipped with means of passive detection sufficiently superior to that of the target. SSK's equipped with powerful array systems might exemplify such a possibility.

There is also the possibility of attempting to close to Hydroduct range making full use of active sonar, assuming that stealth has been lost as a result of earlier unsuccessful attack by Hydroduct or other weapon, or as a result of counterdetection prior to an attack. It is conceivable that, under such conditions, a high speed weapon might provide the only means of attempting to sustain an attack or seek a follow-up opportunity. For example, the possible use of active sonar by a transiting submarine to protect itself against a waiting submerged attacker could result in submergence of the target and loss of passive contact. However, active search by the target having been the cause for loss of stealth, active sonar could be employed by the attacker to maintain the contact, and effort to attack could be continued by means of echo-ranging.

Although comprehensive consideration and investigation of the preceding examples would be required to determine their feasibility, these assumed cases provide sufficient variety to serve as a basis for examination of the general requirements of fire control and launching systems in the submarine-vs-submarine category.

3. SUBMARINE-VS-SURFACE VESSEL:

Although the Hydroduct could be used to attack virtually any highly vulnerable and lightly defended surface vessel, it is difficult to conceive appreciable opportunity as an offensive weapon in this category. Its use in defense

against attack by antisubmarine vessels, however, appears to offer an excellent possibility. Although the submarine's initial effort when under attack by an ASV would be to evade and escape, and the presence of the Hydroduct would not be expected to alter this effort, the Hydroduct would provide the submarine a weapon with which it could return fire when brought within range of modern thrown or propelled antisubmarine weapons. With presently conceived versions of the Hydroduct, multiple hits would probably be required to sink the ASV. However, a single hit would certainly hinder the attack and assist the submarine's efforts to escape. The threat alone might greatly improve the submarine's chances by denying the antisubmarine vessel complete freedom to approach without fear of counterattack. One argument against the use of such weapons by a submarine under ASV attack is that the submarine's presence would be confirmed, its location "pinpointed", and its advantage of stealth removed by the firing of such ordnance. On the other hand, however, modern antisubmarine tracking systems leave the submarine little stealth to protect when brought to close range. If the submarine faces imminent destruction, having failed in its efforts to evade, there should be little reluctance to open fire on its attacker and to employ active sonar to its fullest advantage in the fire control.

The evading submarine's probable effort to submerge to maximum depth introduces one serious disadvantage to the use of Hydroducts in this application. The submarine could not submerge below 300 feet of depth without sacrificing the opportunity of using the weapon. This restriction would not be present with the anticipated performance of the Hydroduct, however, since operable depths of better than 1000 feet are predicted.

Although this possible application for the Hydroduct is similar in many respects to the submerged submarine versus snorkelling target case described before, there are distinct differences which appear to be significant to the fire control and the launcher, and to the over-all quality of the system's performance. If it is assumed that the submarine would first attempt to escape and would open fire only when its position were presumed known by the attacking vessel, the submarine would be involved in evasive maneuvers simultaneously with attempting to aim and fire the Hydroduct. Such maneuvers might include "zig zag" courses and high submerged speeds, which would obviously have serious degrading effects on the fire control. Also, since it is probable that the ASV would be astern the submarine, ability of the Hydroduct launcher to fire aft would be required.

4. SURFACE VESSEL-VS-SUBMARINE

The possibilities offered by the Hydroduct as an antisubmarine weapon in this category appear particularly interesting. The advantage of being propelled underwater at high speed versus reliance on sinking to reach a submerged target becomes increasingly significant with increasing target depth. Some of the Hydroduct's potentialities for this possible application are indicated by the following comparisons to Weapon "A":

SECRET

	<u>Weapon "A" (Note 1)</u>	<u>Hydroduct (Note 2)</u>
Maximum range.....	800 yd	1000 yd (Note 3)
Minimum range.....	400 yd	(Note 4)
Missile		
Diameter.....	12.75 in	9 in
Length.....	102.5 in	72 in
Weight.....	500 lb	215 lb
Warhead.....	263 lb HBX	35 lb HBX
Fuse.....	Influence	Contact
Lethal radius (est.).....	19 ft	5 ft
Time to reach target at 800 yards (approximately)		
Target 100 feet deep.....	15 sec (Note 7)	(Note 5)
Target 200 feet deep.....	17 sec	(Note 5)
Target 300 feet deep.....	20 sec	10 sec
Target 600 feet deep.....	28 sec	(Note 6)

NOTES

- (1) Values obtained from Reference 13, and do not include possible improvements since date of that publication.
- (2) Comparison here is made to present 9-inch version, although modification for surface-to-submarine application would be probable.
- (3) Maximum usable range when fired from surface approximately 900 yards.
- (4) Minimum range would depend upon launcher trainability (in depression).
- (5) At 800 yards range, target immune to Hydroduct above approximately 240 feet of depth because of trajectory fall-off.
- (6) Hydroduct inoperable below 300 feet.
- (7) Based on air flight of 12 seconds, and terminal sinking rate of 36 feet per second.

The figures presented here are meant for comparisons only and should not be interpreted rigorously. Improvement in range of both weapons is probable, and larger versions of the Hydroduct could be developed for such applications, perhaps with influence fuse mechanisms and larger warheads. The significance of these comparisons lies primarily in the time to reach a target 300 feet deep at the 800-yard range. The "dead time" of the Hydroduct is in this case only half that of Weapon "A", thus materially reducing the probable evasion error of the attack. In the comparison made here, the greater lethal

SECRET

SECRET

radius of Weapon "A" is much in its favor, and its ability to sweep all possible depths of the target is a distinct advantage, particularly in compensating for the large probable error of depth determination. Weapon "A" furthermore allows no depths of immunity to the target. The 300-foot depth limitation of the Hydroduct appears to be a serious obstacle to its use in this ASW application, since its potential advantages over Weapon "A" are at the deeper depths, and an abrupt "cutoff" at the 300-foot level precludes realization of these advantages. Development of the Hydroductor, enabling depths of 1000 feet or better, would eliminate this obstacle.

The air flight of Weapon "A" has a dispersion of 50 feet at maximum range, or a lateral dispersion of 20 miles. To this must be added the underwater dispersion, described in Reference 13 as "considerably smaller." Superiority of the Hydroduct in this regard seems probable if the present estimate of lateral dispersion can be attained. Depending upon the range and angle of water entry, the air dispersions of Weapon "A" are more or less longitudinally to give elongated sinking patterns, which, if the target is aligned from astern, are compensated by the target length. Because of the Hydroduct's susceptibility to greater "vertical" than "horizontal" dispersion, it might possess no dispersion superiority "longitudinally." Analyses to enable direct comparisons of the two weapons would be required before firm conclusions could be made, but an over-all superiority of the Hydroduct in this respect seems possible.

Weapon "A" is capable of firing a total of 22 rounds in ripple fire at five-second intervals using a completely automatic "ready service" magazine, or a total of 11,000 pounds of ordnance per loading. A comparable weight of Hydroduct missiles would equal approximately 50 rounds, based on the 9-inch version.

Thus, the superiority of lethal radius offered by Weapon "A" is offset by three potential advantages of the Hydroduct -- lower lateral dispersions, more total rounds, and shorter lengths of "dead time." The first of these would require sufficient tests and analyses to substantiate, but is of particular interest because the minimum dimension of the probable target aspect would occur laterally. The second suggests either salvo or fast ripple fire of Hydroducts, perhaps with pattern control. The last of these advantages, however, appears the most significant if the contemplated deep submergence of future submarines is employed as defense against attack from the surface. At a target depth of 1000 feet, for example, Weapon "A" would have a total dead time of nearly 40 seconds, whereas a propelled underwater "rocket" such as the Hydroductor might require less than 15 seconds. Graphical comparisons between Weapon "A" and both the Hydroduct and an assumed Hydroductor are presented on pages 27 and 28 to illustrate the above discussion. It is, of course, apparent that considerable analytical study would be required to elevate the preceding to more than pure surmise, but for reasons described, the potential of the Hydroduct and Hydroductor in this application appears to merit further investigation.

SECRET

SECRET

There are many other considerations beyond those discussed above which would have considerable influence on the evaluation of this possible application. The launcher is clearly one of the most important of these, since the Hydroduct is intended for underwater launchings and therefore presents a considerably more serious problem than a deck-mounted launcher. As is the case with previously discussed applications for the Hydroduct, the ability to attain adequate aiming accuracies is of fundamental concern and is further aggravated in this case by the pitch and roll of the surface vessel as compared to the "stable platform" offered by the submerged submarine. These and other factors must be considered in any investigation of surface-to-submarine possibilities, but until the basic studies suggested by the preceding paragraphs have been made, these factors could not be adequately evaluated.

5. OTHER POSSIBLE APPLICATIONS

Several other applications for underwater rockets are worth consideration, although for the present they appear secondary to the preceding possibilities. If the indicated low levels of dispersion can be realized in actual practice, the possibility is suggested of firing small versions from a special barge equipped with a suitable high resolution sonar system as a means of neutralizing bottom-laid mines. By firing from a "safe" distance in the order of 150 yards, a ballistic dispersion of as little as five feet standard deviation might be attained. Neutralization of the mine, either by detonating or flooding, might be possible with small Hydroducts carrying small warheads. The present 4.5-inch test version might be adaptable to such a purpose. The principle uncertainty of this application lies in the ability to locate the mines and properly aim the launcher. Aiming errors could be minimized by determining and correcting for known sources of error such as thermal gradients and currents, and could be compensated by use of salvo patterns or by raking the presumed target position with ripple fire. The probable number of rounds required, however, could be excessive unless excellent accuracy of aim could be achieved.

The possible use of fixed submerged batteries of Hydroducts situated at harbor entrances might be worth consideration. Used in conjunction with warning sonar such as the "Herald" system, and controlled by a shore station, such batteries might enable complete protection against the entry of small or "midget" submarines.

Consideration could also be given to the development of "special purpose" vehicles such as small high-speed surface craft or submersibles equipped with Hydroducts to serve such special purposes as convoy screening, etc.

SECRET

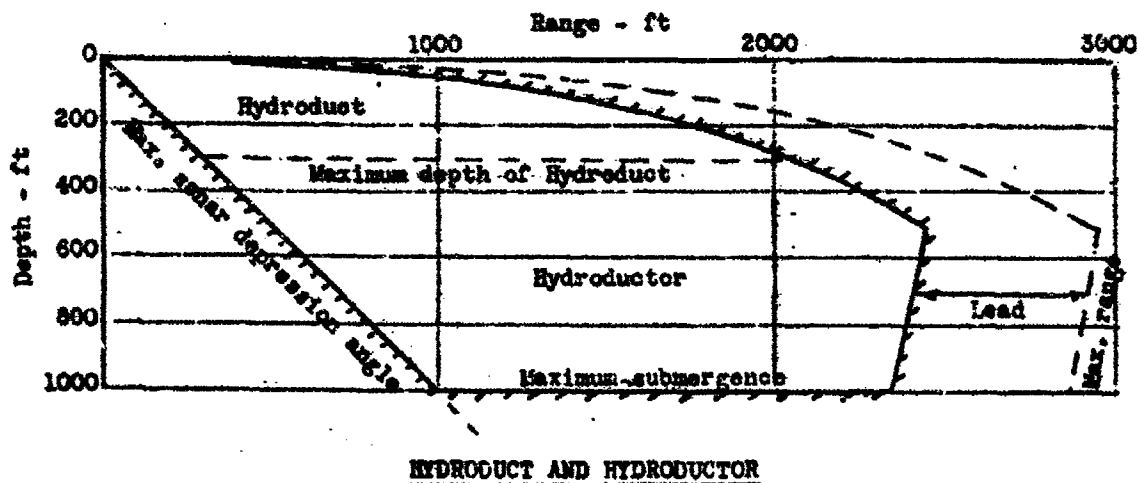
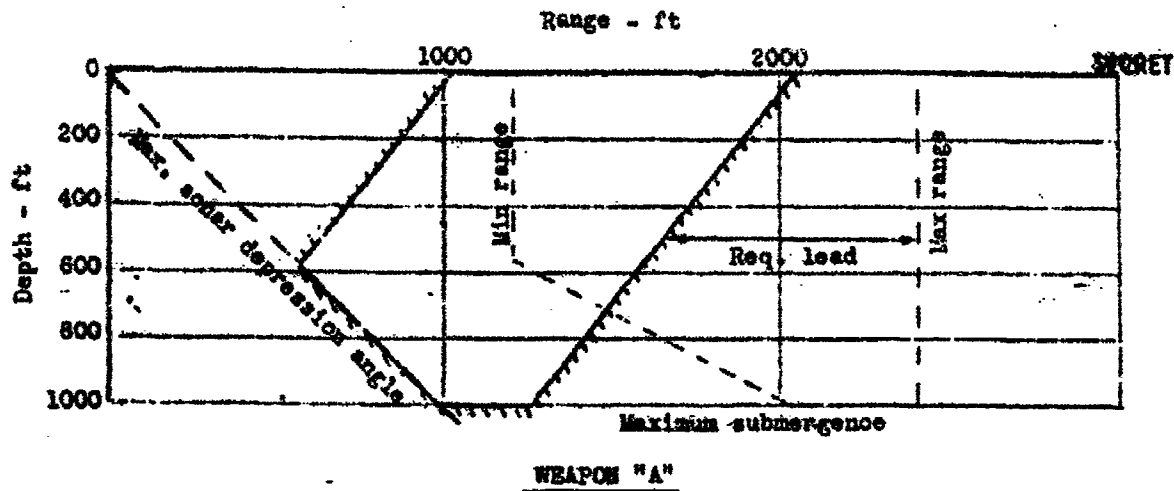

The above diagrams give schematic comparisons of the envelopes of target position (in range and depth) relative to firing ship at time of fire. The envelopes are based on attacking the target submarine from astern, with the target attempting escape at a submerged speed of 18 knots. The following values were assumed for this comparison:

Weapon "A"

Maximum Range	800 yds
Minimum Range	400 yds
Flight time at maximum range	12 secs
Sinking rate	38 fps

Hydroduct and Hydroductor

Maximum-Range	3000 ft
Minimum fall-off at 3000-foot range	240 ft
Flight time at maximum range	16 secs
Maximum depth of Hydroduct	300 ft
Maximum depth of Hydroductor	1000 ft
Maximum depression angle of launcher	45 degs
Maximum sonar depression angle	45 degs
Maximum target submergence	1000 ft

FIG. 4 - SCHEMATIC RANGE COMPARISONS OF WEAPON "A" TO HYDRODUCT AND HYDRODUCTOR

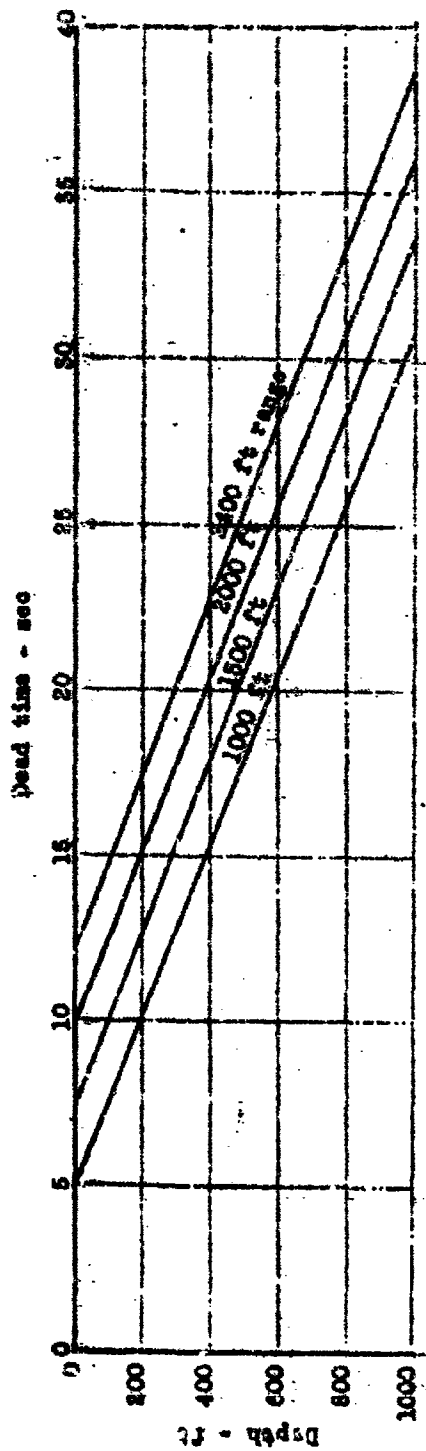
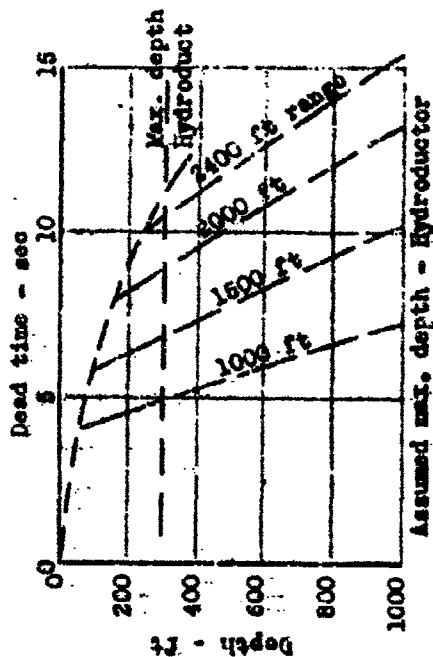

FIG. 5

SCHEMATIC "DEAD TIME" COMPARISONS OF WEAPON "A" TO HYDRODUCT AND HYDRODUCTOR FOR VARIOUS HORIZONTAL RANGES, SHOWING EFFECTS OF TARGET DEPTH



E. FIRE CONTROL CONSIDERATIONS

1. GENERAL

It is the problem of fire control that appears to offer the greatest obstacle to Hydroduct weapon system performance. The ability to aim the weapon with sufficient accuracy to realize the benefits of its low level of ballistic dispersion is of primary concern, and it is probably this question that will ultimately determine the system's limitations. The study reported herein was not of sufficient scope to undertake the investigations and analyses required to resolve this question, and therefore cannot attempt to describe the problem in more than qualitative terms. The following are thought to be the most significant considerations relating to the fire control problem, and those which future investigations should seek to evaluate in order that realistic definition of Hydroduct system performance capabilities can be made:

a. Probably the greatest inherent difficulty in aiming the Hydroduct is the requirement for three-dimensional positioning of the target. As described earlier, the missile is susceptible to a number of causes of "vertical error", and a rapid degradation of effectiveness can be expected with loss of elevation aiming accuracy. If the target is submerged, the determination of either its depth or the elevation angle of its relative position is required, and the accuracy of doing so is of vital concern. The difficulty of accurately determining target depth by sonar makes this problem particularly acute.

b. Active versus passive fire control is a fundamental consideration to the Hydroduct system. If echo-ranging were denied the attacker, triangulation would be required for determination of slant range, and the accuracies attainable by such means are inherently poor. The AN/BQR-6 sonar is currently under development as a means by which a submerged submarine can determine the horizontal range of a surface target passively. This system uses the "JT" hydrophone to measure the elevation angle of arrival, and from the submarine's known depth calculates the horizontal range by triangulation. Range accuracies within 10% to 20% are considered possible with this system, depending on depth, at ranges of 1500 yards. Against a submerged target, however, triangulation by this system would not be possible. The measured angle of arrival of target noise would not enable resolution of target position without an intercept, the only means of providing for which would be determination of slant range by echo-ranging. To enable an attack upon a submerged target entirely by passive means would require a somewhat elaborate plan of tracking prior to the attack in order to provide intelligence not available by direct measurement. Predetermination of probable depth of the target, for example, could be used as an intercept with the measured elevation angle to enable solution of a presumed position. The

complexities and probable errors of such techniques, however, do not appear promising, and it is considered reasonable to assume that active sonar would be required in the fire control with submerged targets. Against surface or snorkelling targets, this would not necessarily be the case, since the known depth of the target and the measured elevation angle enable the solution by triangulation. However, echo-ranging would enable a considerably more accurate solution against such a target, the range error being of negligible magnitude, and the attacker having precise knowledge of his own depth. This solution would not require a measured elevation angle, eliminating the problem of refraction effects on the measured angle of noise arrival. It is concluded that active means would be required in the fire control against a submerged target, while passive means could be used against surface or snorkelling targets, but with greater accuracy possible by active means.

c. The reluctance of a submarine to use active sonar would have considerably less foundation with the Hydroduct than with other weapons, provided that it were used only as a last correction in the fire control. If detection, tracking, and the approach could be performed satisfactorily by passive means, the use of a single "ping" as a final resolution of target position would grant little advantage to the target if it were detected, provided of course that additional maneuvering and other time-consuming corrections were not required by the attacker. If a rapid correction could be made, the target would have little added opportunity to evade, counter, or otherwise attempt to thwart the attack. Without a "ping", the attacker's presence would be known at the instant of firing, allowing the target 15 seconds or less for countermeasures. The use of a "ping" as a last instant aid to fire control would add little to the target's evasion time. Thus, the high speed of the Hydroduct appears to give it a distinct advantage over slower weapons by permitting use of active fire control without serious sacrifice.

d. Another definite advantage resulting from the Hydroduct's speed is the simplification of the prediction aspects of fire control. Little degradation of hit probability would be expected from a reasonable error in predicting the target's motion during the dead period. A simple calculation of lead, probably never greater than one length of the target, would probably suffice. On the other hand, a deliberate effort to close to Hydroduct range would create a somewhat more difficult tracking problem, and attainment of a reasonably close approach to the desired attack position prior to "last instant" use of echo-ranging might require a complex and skilled procedure. The use of an infrequent "ping" during the latter stages of approach might benefit the attack despite the risk of its being detected.

e. The "examples" of possible Hydroduct applications described in the preceding section present somewhat different fire control problems, each application being distinguished by its own operational background and attacking situation. Following are some of the basic considerations in each case:

(1) The submerged attacker versus snorkelling target, with deliberate closing to Hydroduct range, described on page 21, presents the "ideal" situation from the standpoint of fire control. This situation presumes that the attacker has succeeded in avoiding counterdetection and has attained a favorable attack position. Passive bearing measurement in the latter stages of approach should enable final aim in azimuth and partial elevation aim, particularly if elevation angles of arrival have been measured during the approach. With the target presumed to be in the desired position, a single "ping" would enable that position to be confirmed and a final fire control solution made. Following the initial salvo, successive firings could be made with continued use of active sonar.

(2) The submerged attacker versus snorkelling target with contact having occurred "inadvertently" within Hydroduct range differs from the previous case primarily in the inability of preparing and accomplishing partial aim prior to contact. Intelligence required for the attack does not differ from that of the preceding case, but the probability of a favorable attack position being attained is considerably lower and immediacy of attack is vital. Consideration could be given in such situations to sacrifice of "stealth" by immediate use of echo-ranging as a means of bettering the attack.

(3) In the cases of both attacker and target being fully submerged, it is doubtful that satisfactory attacks could be made entirely by passive means. Positioning of the target would require the use of echo-ranging to measure the slant range and measurement of elevation angle to determine target depth. If the latter case, described on page 22, of deliberately closing to Hydroduct range would permit a reasonably accurate determination of probable target depth prior to attack, the final fire control solution might be considerably improved by eliminating the necessity of measuring elevation angles simultaneously with echo-ranging and final solution. In the case of "inadvertent" contact between two submerged submarines, a rapid fire control solution would be essential and, as in the foregoing case of inadvertent contact of a snorkelling target, consideration could be given to full use of active sonar immediately upon contact.

(4) The case of a submarine defending itself against an attacking ASV is fundamentally the same as the submerged attacker versus snorkelling target except for the complications that the target would probably be astern the submarine, and the submarine would be simultaneously attempting evasion. If echo-ranging would materially benefit the submarine's probability of hit, there should be little reluctance to use it, at least under the last ditch assumptions described on page 22.

(5) The fire control problem for the surface vessel-submarine application of the Hydroduct is fundamentally the same as that for Weapon "A" or thrown weapons such as "Hedgehog." Bearing, range, and depth of the target are required for all such weapons. The relative effects of fire control errors differ, however, and despite the fire control solution being fundamentally an identical problem for both Weapon "A" and the Hydroduct, it cannot be assumed arbitrarily that the fire control system for Weapon "A" would suffice for the Hydroduct. Weapon "A", for example, has the ability to "sweep out" a relatively large depth error, an ability which the Hydroduct does not have.

f. The applicability of sonar and fire control systems currently in operation or under development is an important consideration in determining the course and content of future development of Hydroduct systems. Detailed study would be necessary before reliable conclusions could be drawn regarding the deficiencies of current gear for use with Hydroduct weapons and the extent of modification of such gear required. The preceding discussion indicates that the sonars and fire control systems currently available for Weapon "A" may be applicable as well to the Hydroduct in surface-to-submarine applications. As submarine ordnance, however, it appears that the Hydroduct would require modifications or additions to current submarine gear, particularly for attack on submerged targets. The BQR-6 is the only system that provides measurement of elevation angle, and this system has been under development primarily as a passive means for determining horizontal range of a surface target during tracking. The same principle could be employed as an integrated part of a fire control system, with simultaneous use of active means of determining slant range to enable determination of target depth, but the adaptability of the BQR-6 system itself to this purpose seems questionable.

The fire control computer requirements for the Hydroduct are, of course, unique in many respects. The complexity of solution and the required inputs would depend on the sensitivity of system performance to the various causes and magnitudes of bias. Computation of the aim point relative to the measured instantaneous position of the target, such that proper lead and super-elevation are enabled, constitutes a problem the exact solution of which would be complex, involving prediction of all effects on bias introduced by motion of both the target and firing vehicle and ballistic deviations of the missile due to relative motions of the surrounding sea water. However, it is evident by intuition alone that many of the sources of bias and deviation would have negligible or minor effect on the hit probability, and their omission in the fire control would be desirable. Detailed study and analysis would be required to effect the optimum compromise, but it seems reasonable that the required inputs would be within reasonable limits, and might in fact be relatively simple.

F. LAUNCHING CONSIDERATIONS

The requirements for launching present one of the most intangible, and one of the most critical problems of Hydroduct weapon systems. Even if all other aspects of such weapon systems could be resolved without detriment to the Hydroduct's potentialities as an underwater weapon, the penalties and sacrifices of providing adequate launching means might overshadow all of its potential advantages. This is not meant to be an assertion that such would be the case, but an emphasis of the importance of the launcher to the over-all performance and value of Hydroduct systems. It is the launcher that threatens to make the over-all cost of Hydroduct systems excessive. The launcher would impose a "dead weight" penalty on the firing vehicle -- a serious consideration for submarines. Consistent performance of the launcher would be a necessity to maintain low dispersions. The mechanics, particularly the ability to train and elevate the launcher, would have considerable influence on the feasibility of the various possible applications for the weapon. With the possible exception of rigidly mounted, immovable launching tubes, considerable maintenance would probably be required.

Considering the multiplicity of possible means and configurations of launching systems, and the significance of considerations such as those described above, it is doubtful that reliable evaluations of Hydroduct systems could be made until many of the launching problems have been resolved by adequate study, analysis, and test.

Although the launching requirements for Weapon "A" differ entirely from those of the Hydroduct, and any attempt at direct comparison would be meaningless, the seriousness and importance of the launcher problem is indicated to some degree by the Mark 108 launcher assembly of Weapon "A". This launcher enables single-shot ripple fire of 22 rounds, each round weighing 500 pounds, at a rate of one round every five seconds. A "ready service" magazine enables completely automatic firing of all 22 rounds if desired. The launcher is trainable and elevatable. The complete assembly weighs 47,000 pounds without ammunition, and costs approximately \$500,000 per unit in lots of ten. It requires considerable maintenance and must be serviced by expert personnel.

The majority of past effort with the Hydroduct has been directed at development and test of the missile itself. Tests of the 4.5-inch test version were made with special test launchers providing rail guidance and using solid propellant rocket motors for initial boost. Design studies of operational launchers have been made but no such launchers have been fabricated or tested. In view of the preliminary status of launcher development, the study described in this report has not attempted more than a generalized examination of launching problems. Following are some of the requirements and considerations which

are thought to characterize the Hydroduct launching problem and to indicate the need for fundamental studies of possible launching systems:

1. Since the Hydroduct is inoperable without sufficient ram pressure to enable the flow of inlet water, the launcher must provide for initial boost of the missile to a "minimum" speed before free flight can commence. It is intended that sufficient boost be provided for a launching velocity of approximately 250 feet per second. It is preferable to minimize the length of the launcher, and "single-length" launching is contemplated. There are numerous means by which the required boost could be provided, and it is obvious that design of the boost should be guided by the considerations of cost, reliability, maintenance, weight, minimum hazard, etc. No purpose would be served by discussion herein of such possible means of boost since, until the basic launcher requirements have been established, no reasonable investigations could be made of the problems of mechanical detail.

2. Probably the most critical problem associated with the launching system is the question of trainability. A variety of possibilities exists, each having its own considerations of mechanical complexity, weight, cost, maintenance, etc. From the standpoint of maximum utility of the weapon, the "fully trainable" launcher, capable of rapid motion in both azimuth and elevation, is the "ideal". From the standpoints of cost, weight, maintenance, etc., the "fixed" or rigidly mounted launcher represents the ideal. Compromises include launchers trainable in azimuth only with fixed elevation angles, and "elevatable" launchers with fixed azimuth angles. Other possibilities include fixed launchers with multiple elevation or azimuth settings, such as mounting launchers aboard a submarine to enable firing both forward and aft. Some improvement over rigidly fixed launchers, but avoiding some of the complexities of trainability, might be offered by "adjustable" launchers, enabling preattack setting of desired elevation and azimuth, but with aiming accomplished during the attack by maneuvering and trim of the vehicle. These and other possibilities allow a wide variety of conjecture and supposition, and only comprehensive study and investigation could provide any realistic indications of the need for movable launchers and improvements in versatility and effectiveness possible thereby.

With regard to the use of Hydroducts as submarine ordnance, the investigations of missile performance reported herein have considered the launcher fully trainable (elevation and azimuth) in order that the most severe possibilities of cross current and tip-off effects could be examined. However, because of the acuteness of weight and space problems, it appears desirable to concentrate initial effort on possible use of fixed launchers. Studies of launchers and analyses of the improvement in system effectiveness to be gained by trainability should continue in the interests of eventual optimization, but in view of the preliminary state of development and the many uncertainties currently associated with the weapon's potentialities, it is considered advisable to minimize the inhibiting effects of complexities and to concentrate effort initially on developing the simplest practicable system.

In the submarine-vs-submarine applications, the "inadvertent" cases, or other situations preventing approach by stealth, would be most adversely affected, and perhaps precluded, by lack of launcher trainability, and defense against an attacking antisubmarine vessel might be infeasible unless launchers mounted specifically for that purpose were provided. The other cases of deliberate closing to Hydroduct range, however, if tactically feasible, would be degraded considerably less by launcher immobility.

In the surface vessel-to-submarine application, trainability in both azimuth and elevation (or depression) would appear to be an absolute necessity, this being further complicated by the necessity of subsurface launchings rather than deck launchings.

3. Since multiple firings of Hydroducts are contemplated, the launcher must provide either multiple launching tubes which can be selectively fired in either salvo or ripple fire, or means of magazine loading must be provided. The latter involves mechanical complexities, although offering certain advantages if used in conjunction with a trainable launcher and also, perhaps, offering a better means of reloading. However, if the launchers were rigidly mounted, the use of multiple launching tubes would be more consistent with mechanical simplicity.

4. The problem of reloading is another important consideration in launcher design, and this is of particular concern to the submarine. The necessity of surfacing to reload is a serious consideration and could severely hinder the usefulness of the weapon. However, again in the interests of simplification, if rigidly-mounted multiple-launching tubes were employed, the use of sufficient tubes to enable repeated firings should be considered.

5. As another basic problem, the optimum use of a low dispersion missile with relatively large aiming errors would require pattern control. The "optimum" pattern would vary with target aspect and range, and perhaps with other factors as well. Hence, a variable pattern control and a variable number of rounds per firing would be desirable as a means of optimizing hit probabilities and use of ammunition. In submarine-vs-submarine applications, a vertical line pattern is the logical means of compensating errors, and variability in this case would involve optimum vertical spacing. Once again, however, mechanical simplicity would be enhanced by use of a fixed pattern based upon probable target range and aspect, and pre-set in the rigidly mounted launching tubes. The ability to vary the number of rounds per firing, however, should be relatively simple.

6. With regard to salvo versus ripple fire, the latter has the advantage of not compounding the recoil loads on the launcher, its supporting structure, and the vehicle and is probably also superior from the standpoint of hydrodynamic interaction effects.

SECRET

7. There are many considerations other than those given above, as for example the hazard problem, which requires positive ejection of missiles to preclude the possibility of burning the launcher and hull, and assurance that an armed missile cannot contact the firing vehicle. Firing mechanisms, means of missile ignition, possibilities of water damage to loaded missiles and launcher, and problems of corrosion are additional examples. However, until the more basic and fundamental problems discussed above have been adequately investigated, consideration of detailed requirements would be superfluous.

SECRET

SECTION III.

HYDRODYNAMICS AND BALLISTICS

<u>Part</u>	<u>Page</u>
A. General	37
B. Initial Conditions	39
C. Tip-Off	42
D. Dynamic Characteristics	43
E. Deviations	46
F. Dispersion	56
G. Cavitation	58
H. Mutual Interference	61

A. GENERAL

For the purposes of this analysis, the hydrodynamic properties of the Hydroduct have been examined primarily from the standpoint of those conditions or peculiarities which might degrade the feasibility and effectiveness of the weapon under operational use. To accomplish this study, existing test data for versions of this weapon and for similar weapons have, wherever possible, been projected to situations not covered by the tests, but which might be expected to occur in operational use. Theoretical studies have been applied where necessary to supplement test data in establishing the influence of important ballistic parameters.

The effectiveness of the Hydroduct weapon is directly related to deviations of the trajectory and dispersions resulting from hydrodynamic and physical anomalies. As used in this part of the study, deviations are considered to be variations in the mean point of impact introduced directly and uniquely by operational parameters at launching. They will appear in the form of biases of known magnitude and direction, and will not be considered to include aiming errors. Dispersions are in general those variations which are the results of physical differences between vehicles of a statistical nature, and hydrodynamic anomalies introduced by launching operational parameters which influence individual vehicles differently.

Ordinary dispersion patterns have been fairly well established in restricted tests on small test versions of the weapon. These tests are relatively few in number from a statistical standpoint; however, they do provide some indication of the dispersion qualities of the general configuration and philosophy of operation for preliminary evaluation purposes.

The tests referred to above were carried out under essentially static conditions, and do not provide any indication of dispersions unique to launching in salvos from a moving vehicle, or of deviations resulting from known launcher or launching vehicle motions at the instant of launching. Since concepts of operational use of the weapon include launching in salvos from maneuvering vehicles, all of these additional effects must be evaluated, at least in order of magnitude of resulting deviations and dispersions, before the operational effectiveness or feasibility of the weapon can be more completely assessed.

Deviations and dispersions of primary interest in this study and which require evaluation are then those additional ones that arise through conditions at launching introduced by variations in operating parameters and launching methods such as launching vehicle speed and maneuvering, launcher motion, direction of launching, type of salvo, etc. Variations in these parameters, since they are associated with launching, essentially manifest themselves in

SECRET

variations in initial conditions at the beginning of the trajectory; hence, the resulting effects on the trajectory can be evaluated analytically through insertion of the applicable initial conditions in the equations of motion for the Hydroduct and comparing the resulting trajectory with a trajectory computed for the static firing case.

Conversion of operational and design parameters into initial conditions amenable to obtaining quantitative measures of deviations and dispersions can be done conveniently in analyzing the effects of most practical launching vehicle and launcher motions. However, data presently available do not allow insertion of definite quantitative measures of the effects of cavitation (which can result from launching from a moving vehicle) and mutual interference (resulting from salvo launching) in the equations of motion. In these latter cases, this analysis is generally restricted to estimating whether or not cavitation or mutual interference might be expected to occur at various values of launching parameters without any actual quantitative estimates of resulting variations in the trajectory. In general, data that are available indicate that for a weapon of this type both of these items could be expected to have rather large and uncertain effects on the trajectory. Hence, conditions at launching which could induce either cavitation or mutual interference should probably be avoided. A general evaluation of these two effects can then be best expressed at this time in terms of restrictions placed on operational situations to avoid the occurrence of either cavitation or mutual interference.

SECRET

B. INITIAL CONDITIONS

The main effects of launching vehicle and launcher motion is to induce cross currents at the launcher and rotational velocities of the launcher at the instant of launching. These cross currents and launcher rotations manifest themselves in angle of attack or yaw and angular velocities in pitch or yaw of the Hydroduct as it leaves the launcher. Under some conditions, increased relative velocity of the Hydroduct also results.

The influence of rectilinear steady motion of the launching vehicle in inducing angle of attack or yaw at launching is developed in Appendix I. The angle of attack or yaw and the direction of motion of the center of gravity as the Hydroduct leaves the launcher can be directly expressed in terms of Hydroduct launching speed, launching vehicle speed, and angle of launching relative to the launching vehicle. Also, in launching close to the velocity vector of the launching vehicle the relative velocity of the Hydroduct can be substantially higher than the launching speed relative to the launcher, approaching the sum of the launching speed and the speed of the launching vehicle.

If the launching vehicle is moving in a steady curved path, an additional angle of attack or yaw is induced, and an initial angular velocity is imparted to the Hydroduct upon leaving the launcher. The additional angle of attack or yaw is a function of the distance between the center of rotation of the launching vehicle and the end of the launcher, the speed of the Hydroduct as it leaves the launcher, and the angular velocity of the launching vehicle. Angular rotations of the launcher alone will have a similar effect in imparting angle of attack or yaw and angular velocities to the Hydroduct.

Since this study is primarily concerned with submarine launched Hydroducts, all of the values of the operational parameters used in estimating the effects of launching vehicle motion are based on submarine performance data obtained from various available reference material. For the purpose of this study the launcher is assumed to be fully trainable in azimuth and elevation.

Maximum speed considered for the launching vehicle was assumed to be 20 feet per second, in accordance with data contained in Reference 1. This is near the maximum submerged speeds (one hour rate) for the "Guppy" and "SSK" type submarines. Angles of attack and yaw induced at this speed for various angles of launching are shown in Fig. 6.

A launching submarine pitching rate of about 1° per second was assumed from Reference 2, and represents the extreme of full scale trial data on a "Guppy" type submarine in a dive maneuver reduced to 10 knots (≈ 17 fps). The angle of attack produced by this effect is approximately .002 radians for a launcher located 30 feet from the center of rotation of the submarine. The pitch rate of rotation imparted to the Hydroduct is .0175 radians per second.

SECRET

Launching submarine turning rates were obtained from Reference 3 for a "Guppy" conversion. These data indicate maximum turning rates of about .033 radians per second at a forward speed of 20 feet per second as typical of more or less extreme operational values. This induces an angle of yaw of about .004 radians at launching for a launcher located 30 feet from the center of rotation of the submarine.

Actual rates of rotation of the launcher alone which might be used are unknown. Simply to follow a surface target traveling at 50 feet per second in the opposite direction from the launching submarine traveling at 20 feet per second would require a rate of rotation of about .07 radians per second for a range of 1000 feet. Elevation angle rates of about .01 radians per second would be required to follow a limit dive maneuver of a 10-knot submarine diving from the surface and stabilizing out at 400 feet (Reference 2). These situations might be practical as some sort of criteria in cases of launching repeated salvos at moving targets.

There are, of course, many other secondary effects of launching vehicle motion that will influence the trajectory. For instance, the flow pattern around a moving submarine will in itself introduce differences in the direction of the cross stream at the launcher which will influence initial conditions. However, time does not permit evaluation of such additional problems in this study, and the present analysis must necessarily be restricted to those effects that appear offhand to have the largest influence on the effectiveness of the weapon.

SECRET

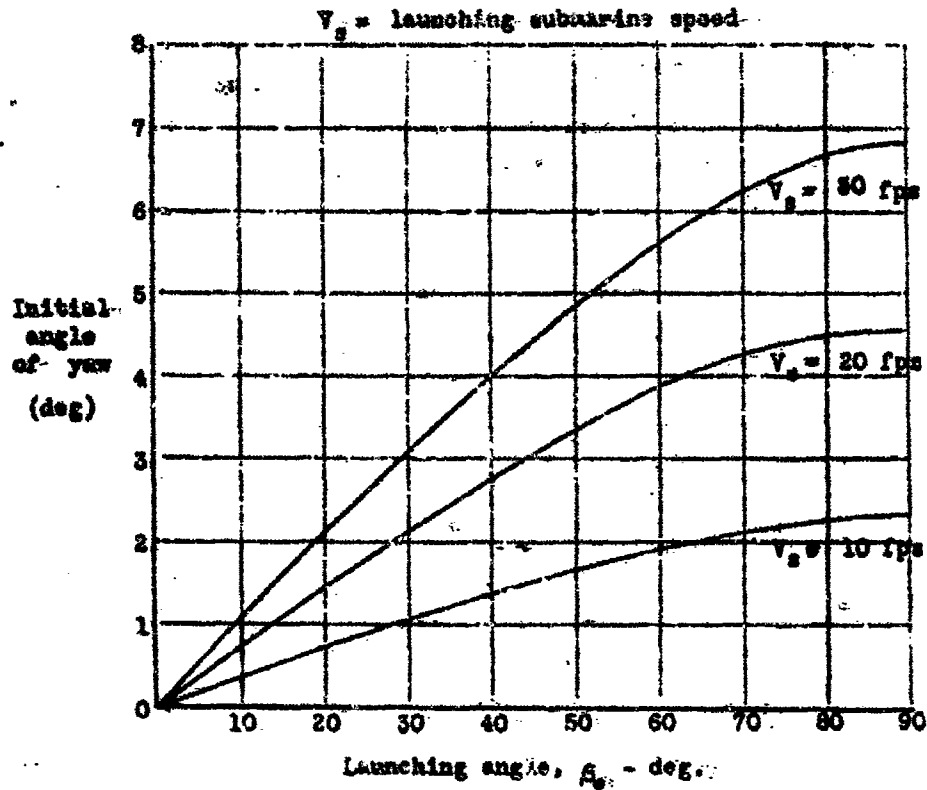

FIG. 6

ANGLE OF YAW DUE TO CROSS-STREAM LAUNCHING

C. TIP-OFF

A factor which may be of considerable importance in inducing initial conditions of angle of attack or yaw and angular velocities of the Hydroduct at launching is tip-off, particularly if the launching submarine is in motion.

If the Hydroduct is not supported rigidly by the launcher during the time it remains in the launcher, both hydrodynamic and gravity effects can result in displacement of the center of gravity, and angular velocities in pitch or yaw of the Hydroduct relative to the launcher axis before the launcher is cleared. These in turn contribute to initial conditions of angle of attack or yaw, angular velocity, and differences in the flight path at the time the Hydroduct leaves the launcher. The magnitude and character of these initial conditions is dependent on launcher design characteristics and on operating conditions at launching. Since the launcher design is not established in final detail as yet, any attempts to analyze the effects of tip-off at this time must necessarily be based largely upon assumed launcher characteristics and interference effects which may not be representative of the final design. However, certain illustrative cases can be useful in bringing out factors in launcher design, and to possibly get some idea of the boundaries of possible results of tip-off.

Studies of proposed launching methods for the Hydroduct indicate that it might be reasonable to assume that the rear of the missile is constrained to move along the axis of the launcher until very close to the exit. Also, it appears conservative to assume that no support is provided by the lip of the launcher after the maximum thickness point of the Hydroduct passes the end of the launcher. With these conditions of constraint, and assuming that both hydrodynamic and gravity moments are effective, the equations of motion describing the tip-off are developed in Appendix VI. Resulting angles of attack or yaw, angular velocities of rotation, and flight path angles as functions of launching conditions are given in this appendix. Translations of the center of gravity during tip-off are quite small in all cases and need not be considered in further trajectory analyses.

D. DYNAMIC CHARACTERISTICS

The magnitude and character of the additional deviations and dispersions resulting from the introduction of various initial conditions at launching outlined in the previous section depend on the dynamic characteristics of the Hydroduct itself and on the magnitude and character of these initial conditions. As pointed out earlier, determination of these deviations and dispersions is implemented through solution of equations describing the motion of the Hydroduct, with the proper initial conditions inserted to describe the character of causative factors.

Approximate equations of motion suitable for this analysis are given in Appendix II. From these equations the space position of the Hydroduct center of gravity can be established, along with the space orientation of the flight path and the axis of the Hydroduct at any time during the trajectory. Comparison of calculated trajectories, including causative factors of interest, covering the range of expected operational conditions with trajectories determined without these effects will give some indication of additional deviations and dispersions which might be encountered. Knowing these, a cursory evaluation of the various conditions at launching can be made in terms of weapon effectiveness and feasibility through hit probability analyses.

The introduction of various initial conditions in the equations of motion for the Hydroduct results in transients occurring immediately after launching, during which the initial disturbed conditions are reduced to steady values, and the Hydroduct experiences translations and rotations in space which are different from the basic trajectory for static-launching conditions. Conditions at the end of this transient period can then be considered as initial conditions for an essentially undisturbed trajectory covering the balance of the flight. Differences in the trajectories at the target are then directly related to the differences accumulated during the transient period.

Examination of the characteristic equation for the Hydroduct developed in Appendix II indicates that the Hydroduct will exhibit the general dynamic characteristics of a small stable vehicle operating at high speed in a dense medium. Motions are well damped, and undamped natural frequencies are high. Therefore, any disturbed motion will be reduced to steady state conditions in a very short period of time. In addition, the high launching speed of the Hydroduct has the general effect of reducing the magnitude of initial conditions resulting from variations in operational parameters at launching. Both of these factors tend to minimize accumulated differences during the transient.

If the transient is of short enough duration, the motion during the transient can be satisfactorily analyzed on the basis of no weight, center of gravity, or speed change. The general form of the transient in angle of attack or yaw and

the flight path angle for these conditions has been developed in Appendix II. For the Hydroduct in the launching condition, and also in the burned condition at a speed of 150 feet per second, these transients have the estimated form shown in Fig. 7. The motion is overdamped, and approximately 99% of the steady state value is reached in about .05 seconds for the launching condition, and about .08 seconds for the low speed condition. In this short period of time no significant changes in physical characteristics would be expected to occur to alter the general character of the transient. The difference between transients for the burned and unburned conditions at the same speed is small, being of the order of a 10% increase in transient time for the unburned condition in each case.

The condition of no speed change during the transient is not strictly allowable since the equilibrium speed of the present Hydroduct is shown to be depth sensitive in Reference 4, with the equilibrium speed going from approximately 275 feet per second at the surface to about 158 feet per second at 300 feet depth. At the greater depths, then, the equilibrium speed is substantially lower than the launching speed, and the Hydroduct will decelerate during the first part of the trajectory. An approximate analysis of this deceleration is given in Appendix V, which indicates that the time to decelerate to equilibrium speed is relatively large, requiring about 8.0 seconds at 300 feet depth. During a transient of .05 to .08 seconds duration, the speed change due to this deceleration will for all practical purposes be negligible, and the transient can be considered insensitive to depth to the greatest depths considered as operationally feasible for the Hydroduct at this time. Any deceleration to equilibrium speed can then be considered to take place entirely during the essentially undisturbed trajectory following the transient.

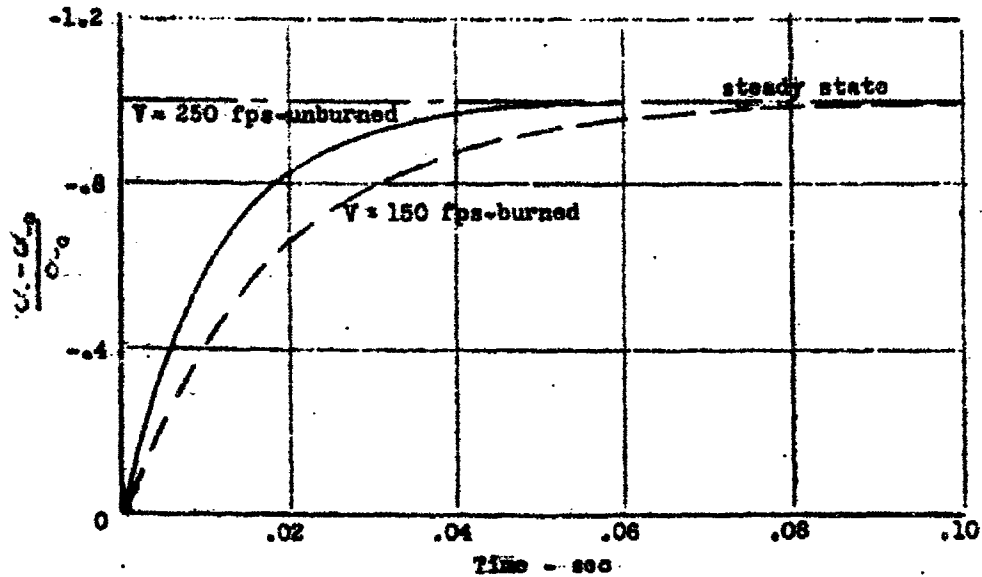

TRANSIENT IN ANGLE OF ATTACK

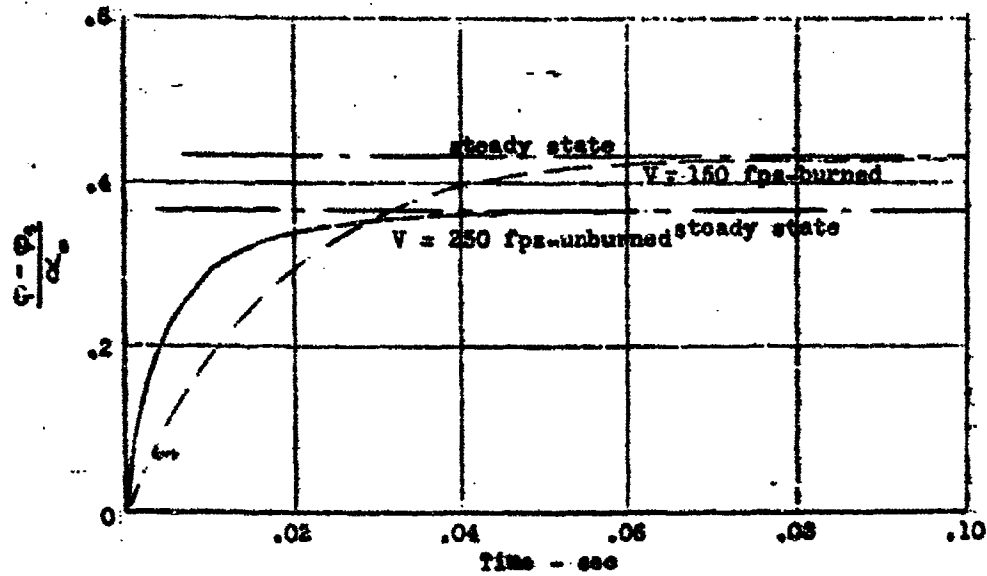

TRANSIENT IN FLIGHT PATH ANGLE

FIG. 7

E. DEVIATIONS

1. GENERAL

For the immediate purposes of establishing the general order of magnitude of variations in the trajectory introduced by cross currents and tip-off, motions of the launching vehicle and launcher during tactical operations will be assumed to be the products of deliberate, known, controlled maneuvers with no random errors introduced by controlling elements or input command signals. The main results will appear in the form of deviations of known direction and magnitude which are dependent upon the conditions of flight path angle and speed at the end of the transient described previously and the dynamic characteristics of the Hydroduct.

Since the transients in angle of attack and flight path angle for the Hydroduct are of short duration, and the translations of the vehicle are small during the transient, it is sufficient for the purposes of this study to consider the approximate undisturbed trajectory to originate at the end of the launcher, but with the direction of the flight path at this point of origin being the value determined with consideration of the transient.

2. VERTICAL TRAJECTORY

The vertical trajectory following the transient in angle of attack and flight path angle occurring immediately after launching can be conveniently analyzed using the approximate expressions suggested in References 4 and 5, and shown in Appendix IV. The general character of the resulting approximate trajectories for representative values of launching parameters are shown in Figs. 8, 9, and 10. These trajectories include the approximate effects of weight change, deceleration from launching speed to equilibrium speed, and variations in equilibrium speed, and variations in equilibrium speed with depth.

The trajectories shown basically exhibit the characteristics of a very stable body with a relatively high ratio of initial fuel weight to total weight. The equilibrium angle of attack for moment balance is quite small, allowing a fair degree of downward curvature to the flight path. The trajectory flattens out considerably toward the end of the flight path when near-neutral buoyancy is approached.

A comparison of the vertical trajectories for static launching conditions with the trajectories including the total estimated effects of cross currents and tip-off indicate variations in maximum total deviations of the order of those shown in Fig. 11 for various typical values of positive elevation angles and extreme values of launching-submarine speed. This figure indicates that deviations of the order of 25 to 30 mils would be the largest that might be expected

to result from launching ahead from a moving submerged submarine. With the Hydroduct limited to operational depths of less than 300 feet, surface targets at slant ranges as low as 750 feet could be attacked with a maximum launcher elevation angle of approximately 25° . From a 60-foot launching depth, this same slant range could be attained with a maximum depression angle of about 14° for targets at a 300-foot depth. For lower slant ranges, higher limits of launcher elevation and depression might be required. However, the probabilities of such target orientations might be sufficiently low to enable limiting elevation and depression of the launcher to these values as a means of reducing cost and complexity.

Deviations due to cross stream alone without tip-off, and hydrodynamic tip-off, both increase with increasing angle of elevation of the launcher. Gravity tip-off has the effect of counterbalancing the hydrodynamic tip-off effects at positive angles of elevation. At high angles of elevation, hydrodynamic tip-off can contribute substantially to the total deviation if launcher design is not carefully constituted.

Trajectory drop-off places some limits on maximum usable slant ranges which are functions of launching vehicle depth and target depth. An estimate of these limits is shown in Fig. 12.

3. LATERAL TRAJECTORY

The mean undisturbed lateral trajectory following the transient is defined by a condition of zero angle of yaw; thus, the projection of the mean trajectory on the horizontal plane is essentially a straight line, the direction of which is defined by the flight path angle at the end of the transient following launching. Some examples of estimated lateral trajectories obtained under conditions of launching at various angles off the bow of a moving submarine are shown in Fig. 13.

The high static stability of the Hydroduct causes it to align itself very rapidly with the direction of the relative wind, and produces a relatively substantial lateral angular departure of the flight path from the relative velocity vector at launching as compared to a less stable configuration.

The resulting lateral deviations for various angles of launching and launching-submarine speed are estimated in Fig. 14. It can be seen that these deviations get rather large for launchings at high angles off the bow of the submarine, approaching the length of some applicable targets at maximum range. Hydrodynamic tip-off actually has a beneficial effect, at least for launchings at angles less than 90° off the bow.

Hydrodynamic tip-off due to motion of the launching vehicle can have rather large effects on the lateral trajectory at high angles of launching due to the relatively large initial angles of yaw existing, as shown in Fig. 14. It has the

SECRET

effect of substantially reducing the total deviation over a large range of launching angles.

Steady turning of the launching submarine at near maximum rates is estimated to produce deviations of the order of 2.5 miles essentially independent of the launching angle. These estimates are based on turning characteristics previously discussed in the section on "Initial Conditions." Launcher motion alone for the more or less fictitious case outlined in that same section would introduce only about 3 miles additional deviation.

The deviations discussed quantitatively above only apply, of course, to the specific cases considered with the assumed tip-off conditions outlined earlier. These deviations can vary considerably with design aspects of the launcher and with variations in the design of the Hydroduct itself. Thus, they cannot be considered as final quantitative values in any sense, but merely represent a preliminary analysis of what appears to be the general order of magnitude of trajectory differences that might be expected to result from variations in operational parameters on the basis of present available information.

SECRET

- NOTES:
- 1: Hydroducts launched ahead in plane of submerged launching submarine velocity vector
 - 2: Submarine velocity - 20 fps
 - 3: Launching depth - 60 ft

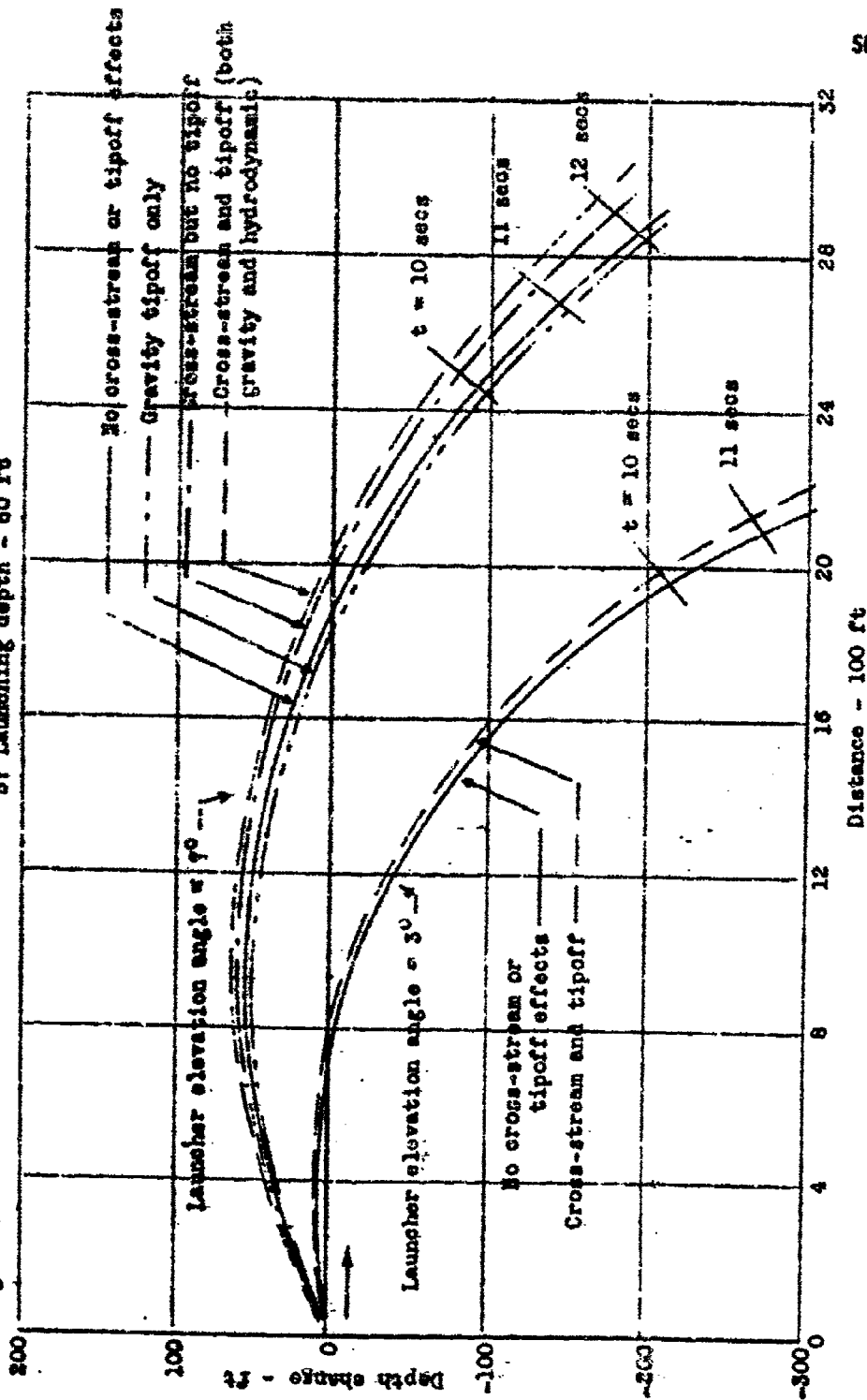

FIG. 8

APPROXIMATE VERTICAL TRAJECTORIES - EFFECT OF CROSS-STREAM AND TIP-OFF

NOTES: 1: Submarine velocity - 20 fps
 2: Launching depth - 200 ft

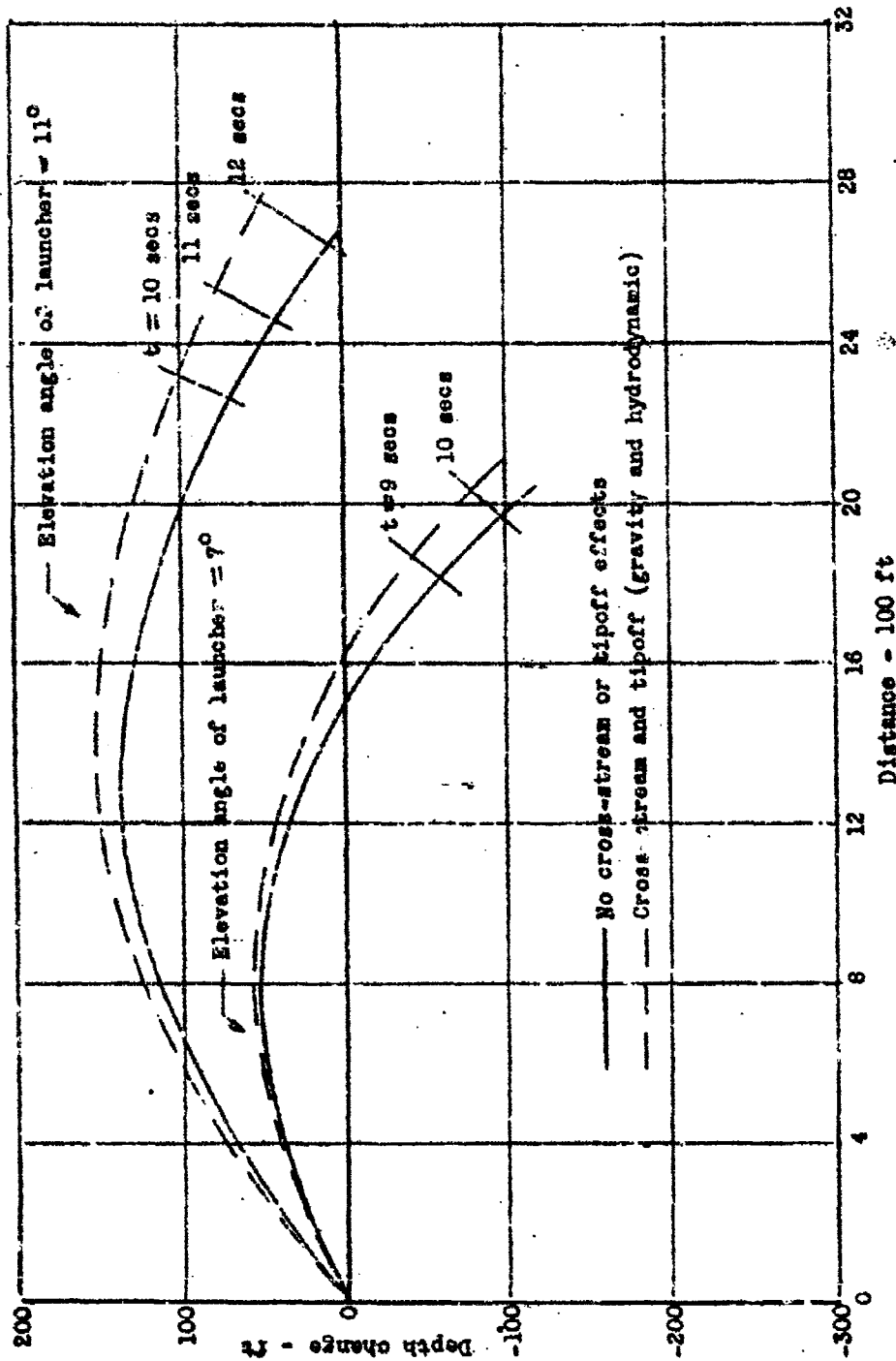
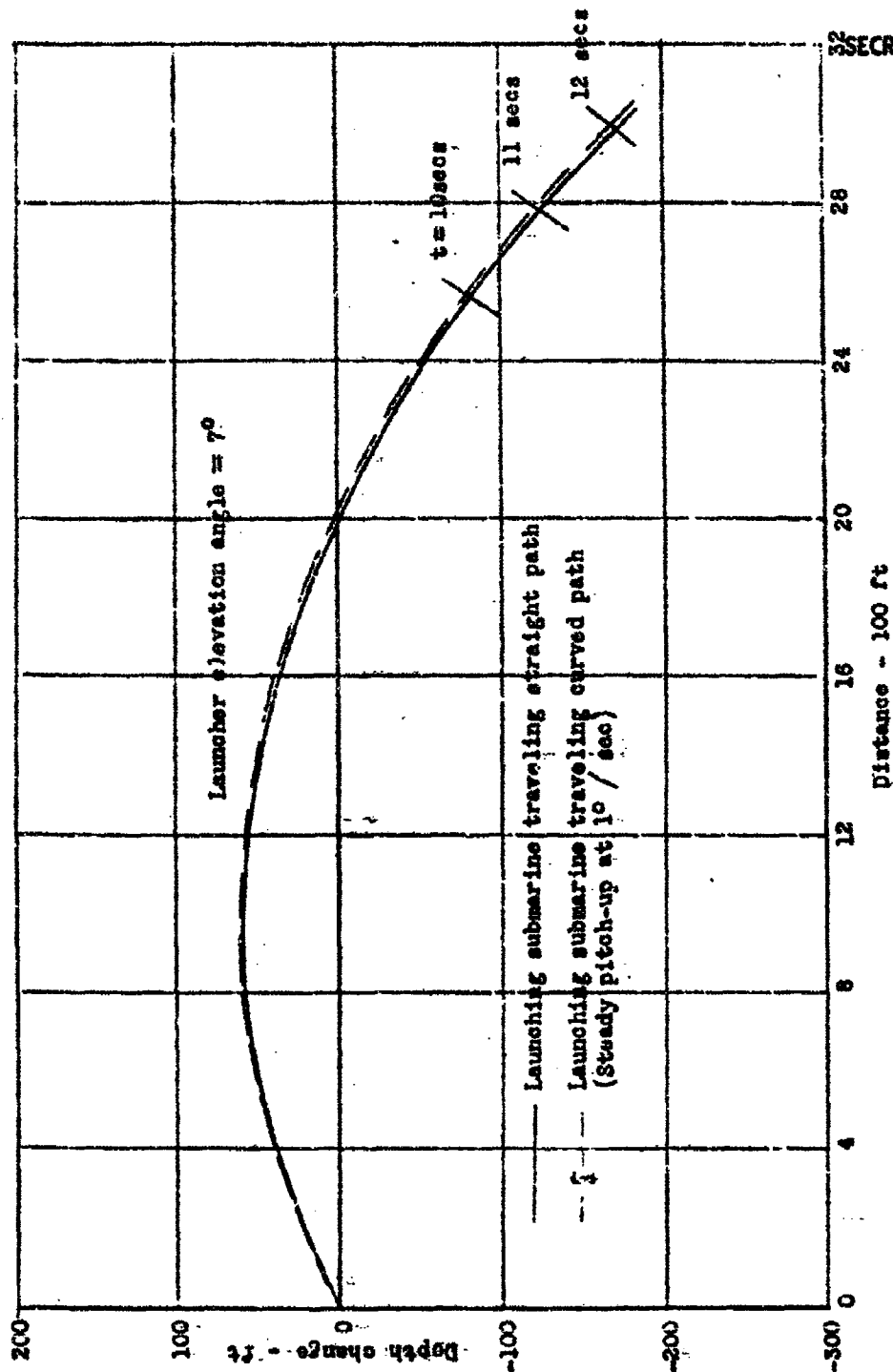

FIG. 9

APPROXIMATE VERTICAL TRAJECTORIES - EFFECT OF CROSS-STREAM AND TIP-OFF

NOTES: 1. Submarine velocity - 20 f/s
 2. Launching depth - 60 ft



SECRET

FIG. 10

APPROXIMATE VERTICAL TRAJECTORIES
 EFFECT OF LAUNCHING SUBMARINE MANEUVERING IN PITCH

NOTES

- (1) Hydroducts launched ahead in-plane of submerged launching submarine velocity vector.
- (2) Submarine velocity - 20 fps.

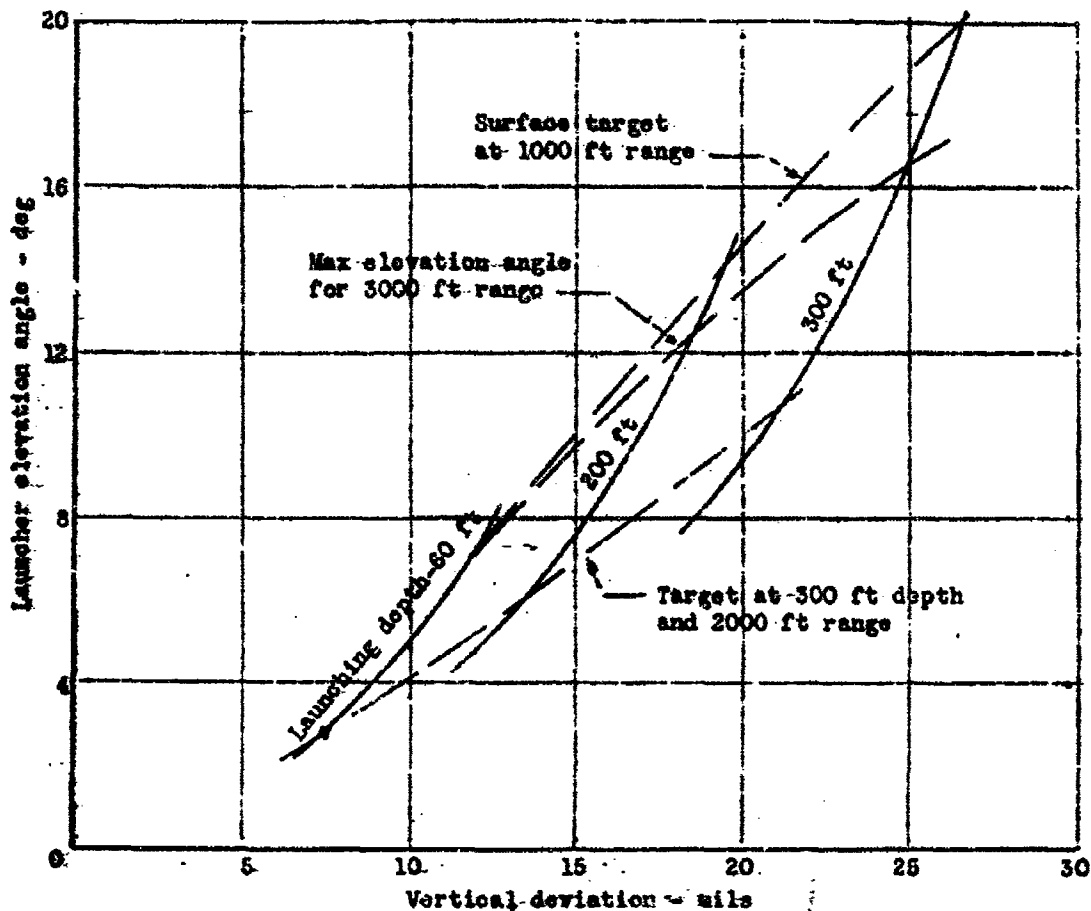

FIG. 11

EXAMPLES OF ESTIMATED VERTICAL DEVIATION
DUE TO CROSS-STREAM AND TIP-OFF

SECRET

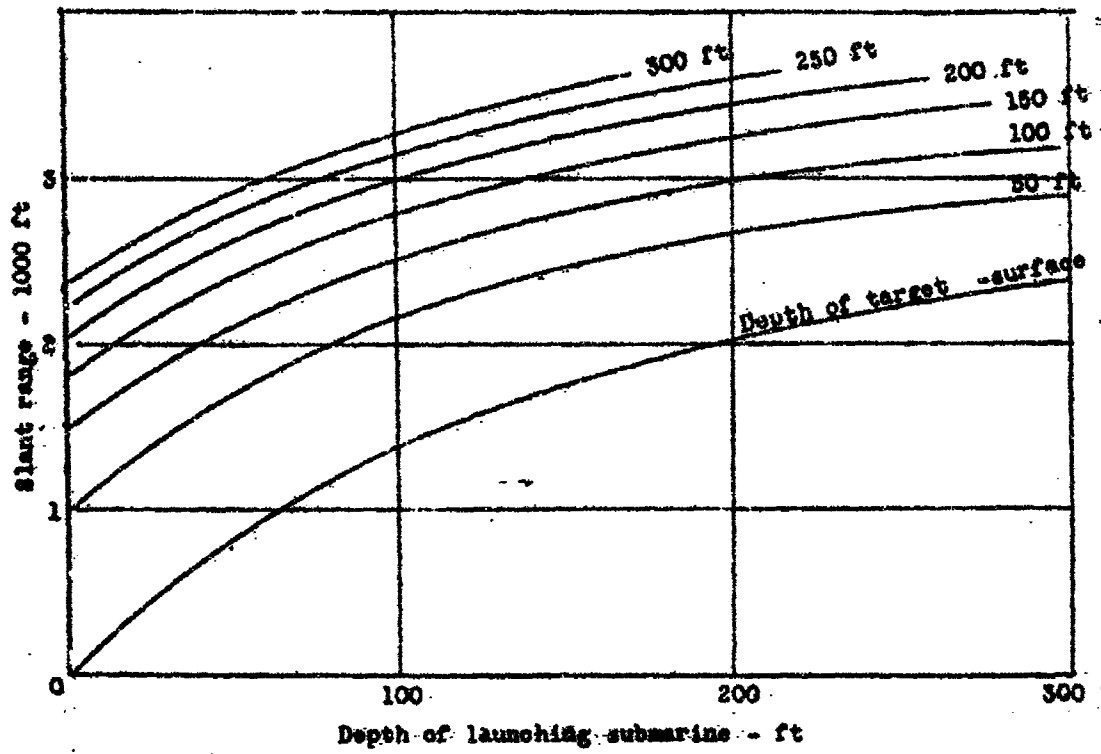

FIG. 12

ESTIMATED MAXIMUM USABLE RANGE

SECRET

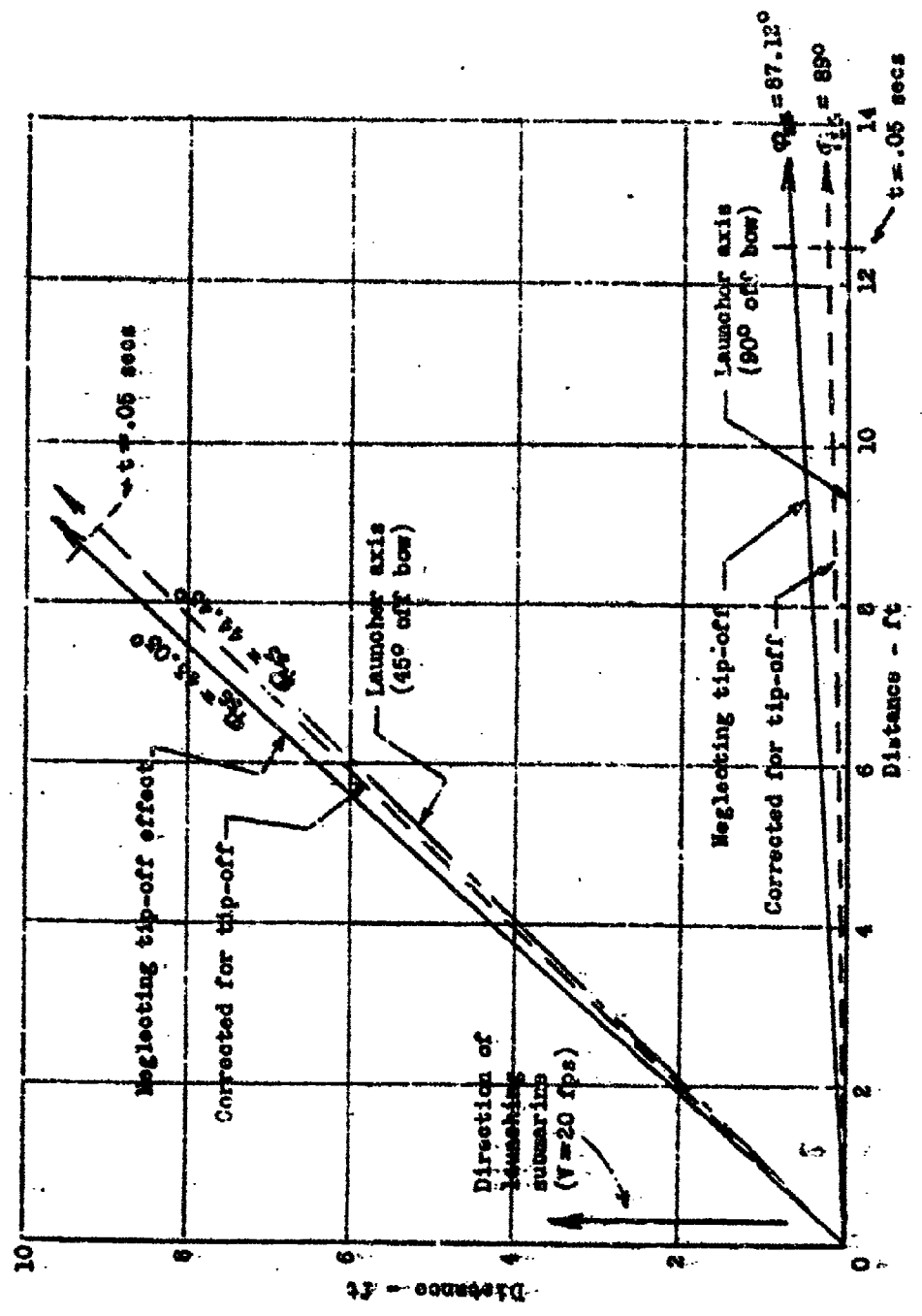

FIG. 13

APPROXIMATE LATERAL TRAJECTORIES:
CORRECTED FOR CROSS-CURRENT AND TIP-OFF EFFECTS
(LAUNCHING SUBMARINE VELOCITY - 20 fps)

SECRET

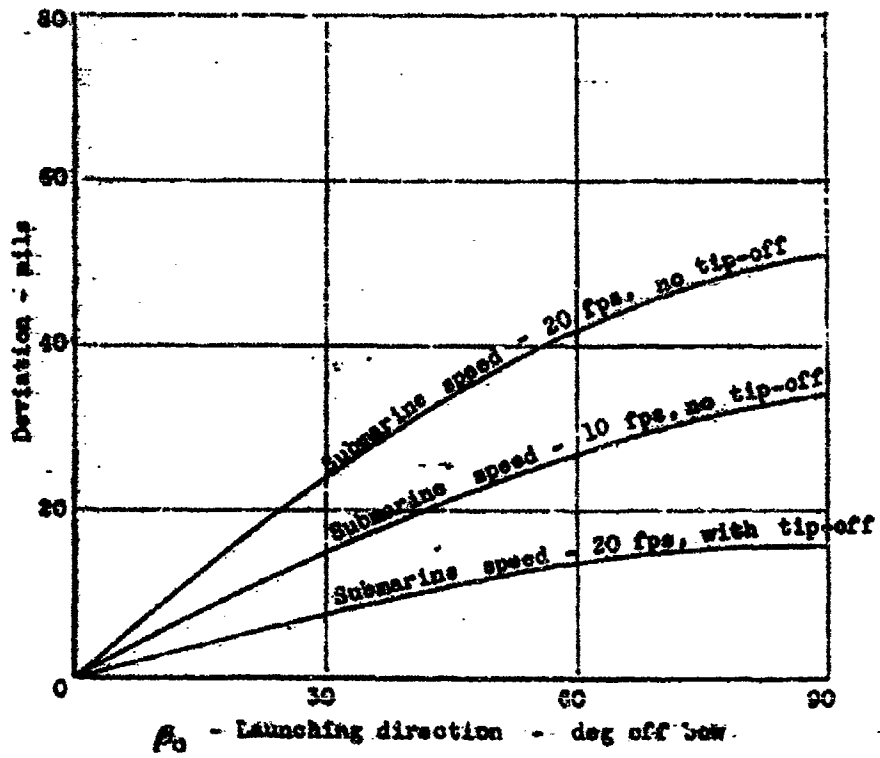

FIG. 14

ESTIMATED DEVIATION IN LATERAL TRAJECTORY
DUE TO CROSS-STREAM LAUNCHING

SECRET

F. DISPERSION

The previous discussion is concerned with factors that primarily induce deviations in the trajectory of known amount and direction, resulting from variations in operational parameters at launching. These variations would not be expected to induce any dispersions in themselves. Any possible resulting dispersion effects would be due to aggravation of dispersion already existing from other causes.

Main sources of symmetrical accidental dispersion for a rotating vehicle are manufacturing tolerances resulting in fin and thrust misalignments, and handling damage such as bent fins and surface dents. These items, in effect, act as forcing terms in the equations of motion as shown in Appendix II. Solution of the equations with these forcing terms included results in a steady state dispersion term and additional terms that die out exponentially during the transient following launching. The components of the dispersion terms in the horizontal and vertical planes are oscillatory in nature, with magnitude dependent upon the frequency of rotation and the dynamic characteristics of the Hydroduct itself. They are in themselves, for all practical purposes, independent of the initial conditions of angle of attack or yaw and rate of change of angle of attack or yaw at launching.

The inherent dynamic characteristics of the Hydroduct appear to be quite favorable as far as minimizing the effects of physical anomalies in producing symmetrical dispersions. The high undamped natural frequency and the good damping characteristics tend to keep the magnitude of the steady state dispersion term low. Actual dispersions cannot be evaluated analytically, however, since no statistical data on accidental damage or manufacturing tolerances are available.

Lateral dispersion data from tests of the 4.5-inch version of the Hydroduct, such as are reported in Reference 6, are indicative of the general order of magnitude of symmetrical dispersions which might be expected to occur under essentially static launching conditions. The average of such tests to date appears to indicate that a standard deviation of lateral dispersion of the order of about 8 mils might be reasonable to assume as possible for this weapon. A standard deviation of vertical dispersion of 16 mils appears to be correspondingly acceptable. Satisfactory tests, however, are still relatively few in number, and statistical confidence intervals are necessarily large. However, these data do give at least some indication of the general dispersion qualities of the weapon for preliminary evaluation purposes.

The introduction of initial conditions of angle of attack or yaw and rate of change of angle of attack or yaw at launching due to cross currents, tip-off, etc., produce deviations which can alter the instantaneous dynamic character-

SECRET

istics of the Hydroduct during the trajectory. Since, as shown in Appendix II, the magnitude of dispersions depends on these dynamic characteristics, the dispersion pattern can be affected by conditions of operational use which primarily induce deviations. The only effect of any probable importance here, however, comes about through the depth sensitivity of the equilibrium speed of the Hydroduct, and any deviations in the vertical trajectory which produce appreciable equilibrium speed changes may alter the undamped natural frequency and damping ratio of the Hydroduct enough to give rise to additional dispersions which should be included in evaluation studies.

Actually, as indicated in Figs. 8, 9, and 10, total deviations in all cases considered gave a net decrease in depth at the target. This has the effect of increasing equilibrium speeds, which in turn should reduce the magnitude of dispersions. This would not be true, however, for launching at large angles of depression against deep targets.

The large ratio between the standard deviations of vertical dispersion and lateral dispersion indicates that variations in thrust from one Hydroduct to the next are appreciable for test vehicles to date. This is attributed in Reference 6 to difficulty in controlling the Alcio grain during the manufacturing process. According to this reference, steps are being taken to improve this situation. Later tests seem to indicate some improvement over earliest results.

SECRET

SECRET

G. CAVITATION.

The results of tests such as are reported in Reference 6 appear to confirm the cavitation-resistant qualities of the general configuration represented by the Hydroduct. These data indicate that cavitation coefficients as low as .075 were reached in some cases before apparent incipient cavitation occurred, while practically no cavitation appeared to occur at coefficients greater than .10.

Data on other similar-finned vehicles and on hydrofoils given in Reference 7 show that the cavitation coefficient for the onset of cavitation will in general increase with increased angle of attack approximately as the square of the angle of attack. Projecting these data to the Hydroduct gives the estimated variation in cavitation coefficient for cavitation onset shown in Fig. 15. These results are expressed in terms of operating limits in Fig. 16. With angles of yaw from Fig. 6, some idea of possible limitations on operating parameters imposed by cavitation of the Hydroduct can be obtained.

Fig. 16 indicates that the Hydroduct can operate at equilibrium speeds without cavitating at depths below about 55 feet at essentially zero angle of attack or yaw. However, with a fixed launching speed of 250 feet per second, static launchings at depths less than 65 feet may produce cavitation. These minimum depths increase with angle of attack or yaw existing at launching due to cross stream conditions. Launching limits for various values of launching vehicle speed and angles of launching are indicated directly in this figure.

The effects of cavitation on the trajectory would be very difficult to assess analytically at this time. When cavitation apparently occurred due to excessive speeds reached during tests of the 4.5-inch version, the trajectory appeared to be extremely erratic and unpredictable. Hence, it is probably desirable to avoid conditions at launching which could place the Hydroduct in situations of depth, speed, and angle of attack or yaw in which cavitation might occur in accordance with the figures referred to above.

SECRET

SECRET

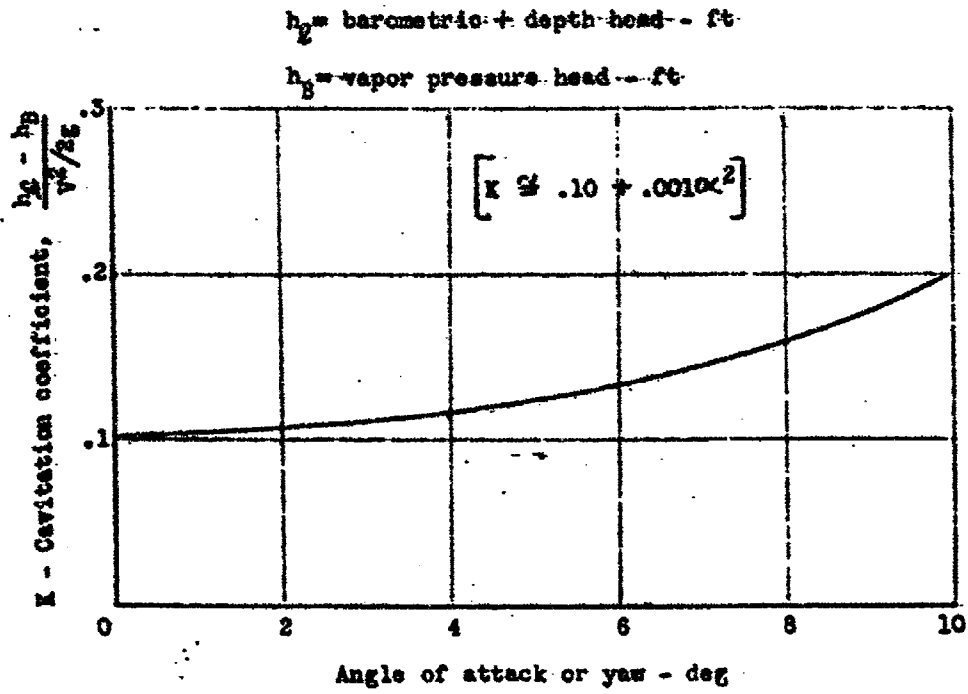

FIG. 15

ESTIMATED VARIATION IN CAVITATION COEFFICIENT
FOR INCIPIENT CAVITATION WITH ANGLE OF ATTACK OR YAW

SECRET

NOTES: 1: Cavitation parameter $K = .10$

2: From any point on graph, region of expected cavitation down and to right.

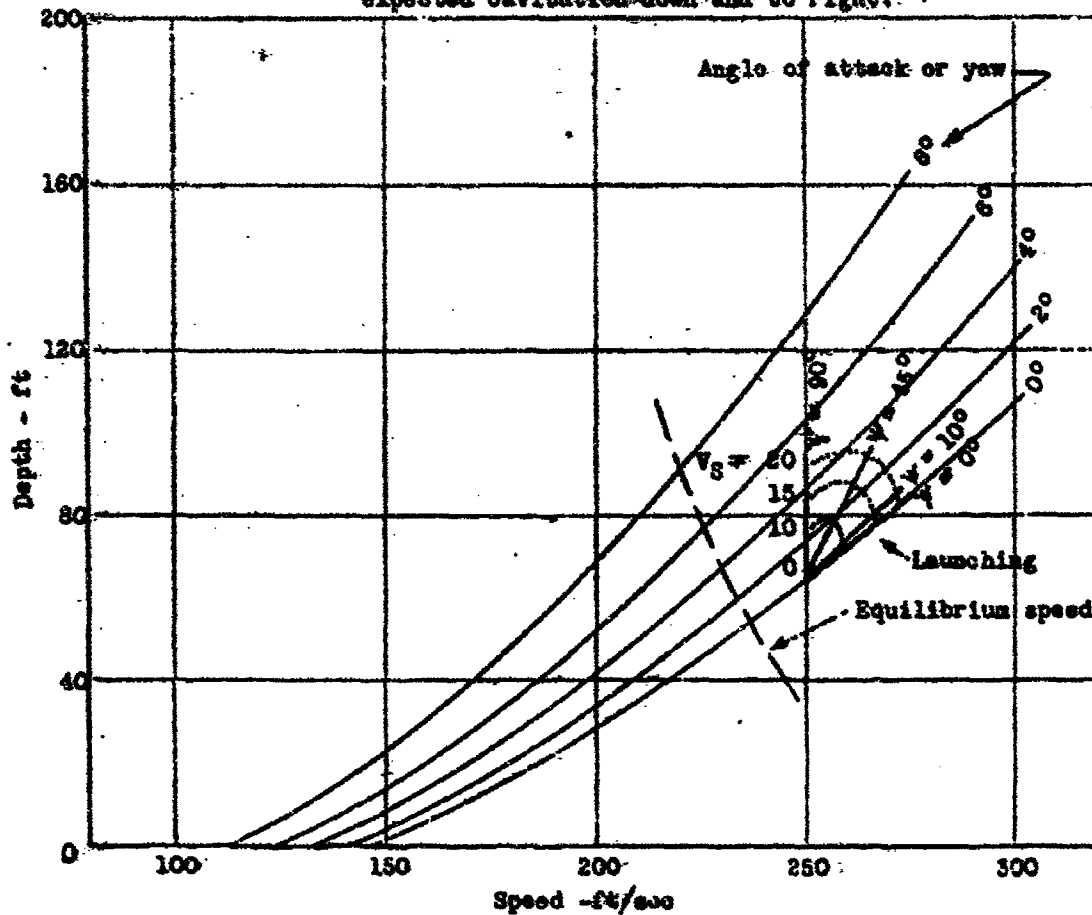

V_s = launching submarine speed, fps.

γ = launching angle off the bow, deg.

FIG. 18

ESTIMATED CAVITATION LIMITS

SECRET

H. MUTUAL INTERFERENCE

Available data appear to give no indication of the effects of mutual interference between wet-running vehicles of the Hydroduct type. Tests on cavity-running rockets, the results of some of which are reported in Reference 8, indicate that launching in salvos with spacing between vehicles of less than one to three diameters produced extremely erratic results, and this method of launching was considered infeasible for operational use. Fast ripple firing, however, produced no erratic effects for intervals between missiles of down to approximately .3 seconds. Thus, it appears that the mutual interference problem for the Hydroduct should not be serious if care is observed in spacing and sequencing. Further investigation is required to more clearly establish the limits of these items for the Hydroduct.

SECRET

SECTION IV.

WEAPON SYSTEM EFFECTIVENESS:

<u>Part:</u>	<u>Page</u>
A. General	62
B. Effects of Dispersion and System Errors	63

SECRET

A. GENERAL

The complete evaluation of the potential effectiveness of a weapon system, as discussed earlier in the report, involves considerably more than determination of hit and kill probabilities. There is a tendency to place strong emphasis on probability of kill as the criterion of a weapon's effectiveness, and there is no doubt that of all the parameters involved, the kill probability is the most tangible for "reasoned judgment" to cope with, and hence the most desired result of a limited analytical study. However, its presentation as a basis for conclusion should be viewed with caution.

Of the many assumptions upon which the calculation of hit probabilities of an unguided missile is normally based, it is frequently the accuracy of aim that exerts the greatest influence on the results. In the case of the Hydroduct, it is apparent that data regarding pertinent aiming parameters are scant and inconclusive, and since the Hydroduct possesses the capability of highly accurate flight, the difficulty of determining and substantiating the aiming accuracy is a serious problem. The scope of this study did not permit the investigations required for any well-founded conclusions regarding aiming errors, or the validity of other basic assumptions that would enable hit probabilities to be calculated and supported beyond reasonable doubt. However, as a preliminary investigation of this problem, analytical studies were made of the relative influence of several operational use factors which were previously indicated to be of concern in this study and having possible degrading effects on hit probabilities of the Hydroduct. The results of these studies are described in somewhat general terms and illustrated graphically on the following pages.

SECRET

A. EFFECTS OF DISPERSION AND SYSTEM ERRORS

The degradation imposed on hit effectiveness of the Hydroduct weapon system by deviations and dispersions introduced through operational use factors discussed previously can only be evaluated in terms of basic dispersion characteristics and system errors involved in locating the target and aiming the weapon. For instance, if either or both dispersions and random errors in locating and aiming are comparatively large, substantial biases introduced by cross stream and tip-off may have little effect on hit probability, and correcting for such deviations may be of doubtful value over large ranges of operational parameters. An illustration of this is given in Fig. 17 for several total random errors which include both aiming errors and dispersions. The relative degradation in single-shot probability increases quite rapidly with vertical bias for low total random elevation errors, and, unless corrected, relatively small biases may reduce total hit probability significantly. However, with large random elevation errors, substantial biases can be tolerated with very little relative decrease in hit probability. At large uncorrected offsets, substantially increased random errors give actually greater hit probabilities. As a matter of fact, unless provisions are made for at least partial correction of large biases which may be introduced by operational factors, there may be some distinct disadvantages in a weapon system having low total random errors. Hit probabilities in Fig. 17 and the following figures were determined with the methods generally indicated in References 10, 11, and 12.

The fall-off in hit probability with horizontal bias is much less pronounced than with vertical bias for beam attacks due to the elongated shape of applicable targets. However, for target aspects close to the bow, the relative decrease in hit probability with horizontal bias becomes much more severe. This variation with target aspect for the single-shot case is illustrated in Fig. 18. The relative degradation in hit probability with bias is improved with increased salvo size, but is increased with reduced random errors, as is indicated in Figs. 19 and 20, for vertical biases. Comparisons of Figs. 18 and 21 will provide an illustration of the influence of salvo size and random errors on the effects of horizontal biases. The salvos assumed here are spaced vertically to maximize hit probability in each case. Optimum salvo spacing varies with system errors, dispersions, and number of Hydroducts in the salvo.

As indicated above, total random errors consist in the main of system errors, which include random errors in locating the target and in aiming the launcher or submarine, and ballistic dispersions. The relative influence of each of these major sources of random error on hit probability for salvos of Hydroducts with optimum vertical spacing is shown in Fig. 22. This figure indicates that only with very accurate target location and aiming does improvement in dispersion result in a very substantial increase in expected number of hits. Considerably more improvement could be attained by the same reduction

in system errors in all cases where system errors are relatively large. The relative improvement to be gained by reduced dispersion as compared to reductions in system errors decreases with increased salvo size. This further de-emphasizes the value of low dispersion characteristics in the presence of relatively high system errors if large salvos are to be used to gain increasing hit probability. Thus, if a high level of accuracy is attainable in target location and aiming of the weapon, low dispersion characteristics will insure a high level of absolute hit probability. However, the requirements for correction of deviations due to such effects as cross stream and tip-off are also correspondingly high to prevent disproportionate degradation of this high initial level of hit effectiveness. To fully exploit the advantages of a low dispersion weapon, it is then imperative to provide other system elements having a high degree of accuracy and the ability to correct for the effects of variations in operational parameters. However, in any case, unless system errors are extremely large, low dispersion will be of at least some advantage in increasing hit effectiveness.

A brief investigation of the characteristics of fire control systems for use with the Hydroduct indicated quite a wide range of reported capabilities of these systems in terms of errors in establishing the position of the target. No data obtained appeared to be consistent enough for specific evaluation purposes. However, the mean of scattered information on maximum bearing errors for the "JT" passive listening and tracking system appeared to indicate that a 50- to 60-mil maximum lateral error in target location might be reasonable, at least for intermediate ranges. These errors would probably increase at shorter ranges due to relative target length increasing the difficulty in establishing the center of the target. Indications are that somewhat better bearing accuracies will be attainable with improved equipment now under development.

The elevation error picture appears to be quite obscure at this time. The only data available were in the form of an estimated range error of about 20% for passive listening with the "JBA" vertical triangulation system at ranges less than 1500 yards with surface targets. This would imply that errors in measuring elevation angle of targets with the "JBA" passive system would be of the order of about 1° if the range error indicated occurred at a maximum slant range of about 1000 yards from listening depths of 300 feet. This agrees with the maximum error of 1.4° in elevation angle deduced from trial data in Reference 9 for ranges of the order of 1000 yards and keel depths of 360 feet. This latter reference expresses doubt as to the certainty of these estimates, however, and arbitrarily assumes a standard deviation representing a maximum error of about four times this value in calculations of hit probability in that report.

Trial data referred to in Reference 9 also indicated that elevation angle accuracies improved at the shorter ranges. This might be expected, since water conditions would tend to have less effect at shorter ranges with larger elevation angles.

SECRET

With submerged targets, it would be necessary to echo-range to fix the position of the target. Range errors would then be quite small, and elevation angles obtained with the "JBA" equipment would have approximately the same errors as those discussed above for surface targets.

Since the information on elevation accuracies attainable with equipment that might be expected to be used for this purpose is of such an inconclusive nature, the most that can be done here is to estimate the general influence of variations in elevation angle accuracies on relative degradations imposed on weapon effectiveness by biases introduced by such items as cross stream and tip-off. For this reason the figures at the end of this section are based on several values of vertical random system errors lying generally between the extremes indicated by trial data and values assumed in other similar studies.

Insufficient time was available in this study to assess the errors inherent in actually aiming the launching submarine or in aiming the launcher. Assuming that each of these errors does not exceed 1° in the maximum, the increase in standard deviation of system error would be small with the existent standard deviations of error in locating the target as high as those indicated above and used in this study.

With typical possible random errors in target location and aiming of the order of 20 miles, fairly large biases can be tolerated with relatively small percentage loss in hit probability. Over most of the conditions shown in Fig. 11, the reduction in hit probability due to uncorrected cross stream launching, Fig. 20, will not exceed 15% to 20% for intermediate ranges of possible system errors. Estimated lateral deviations including tip-off in Fig. 14 will cause only small percentage losses in hit probability, even for attacks well away from the beam of the target (Fig. 21).

Individual effects of launcher rotations and turning of the launching submarine at the rates established previously in the section on "Initial Conditions" would have no appreciable effects on hit probability.

Due to the elongated nature of the target and short time of flight of the Hydroduct, relatively large ranges of target motion can also be tolerated with little reduction in hit probability. Fig. 16 indicates that, at most, only about a 10% reduction in hit probability would result from a submerged target traveling at 15 feet per second at 200 foot depth if the launching submarine were at the same depth (Fig. 4) in a beam attack. There would be essentially no degradation in hit probability for uncorrected target motion in the case of an eight-knot snorkelling target for a beam attack from a 200-foot depth. Comparably low degradations in hit probability would be expected for most practical situations involving moving targets.

SECRET

SECRET

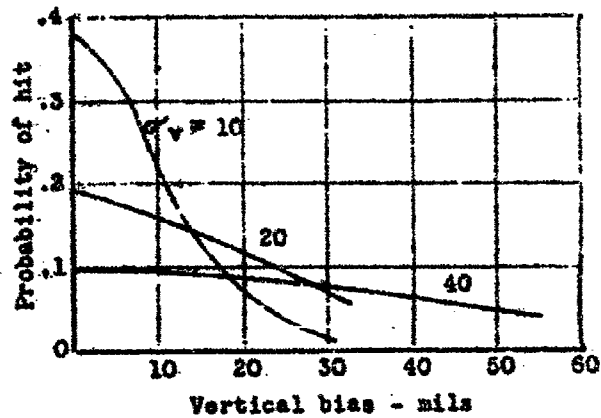

σ_v = standard deviation in vertical error - mils

σ_h = standard deviation in horizontal error - mils

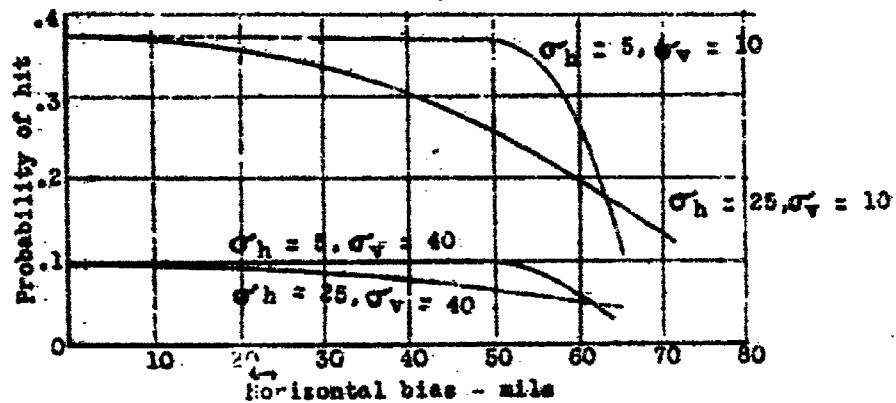

FIG. 17

VARIATION IN SINGLE SHOT HIT PROBABILITY WITH BIAS - BEAM ATTACK

SECRET

SECRET

θ = target aspect (angle off bow or stern of target) - degs

Ballistic dispersion of Hydrodust ----- 8 mils

————— System error - standard deviation = 20 mils

- - - - - System error - standard deviation = 50 mils

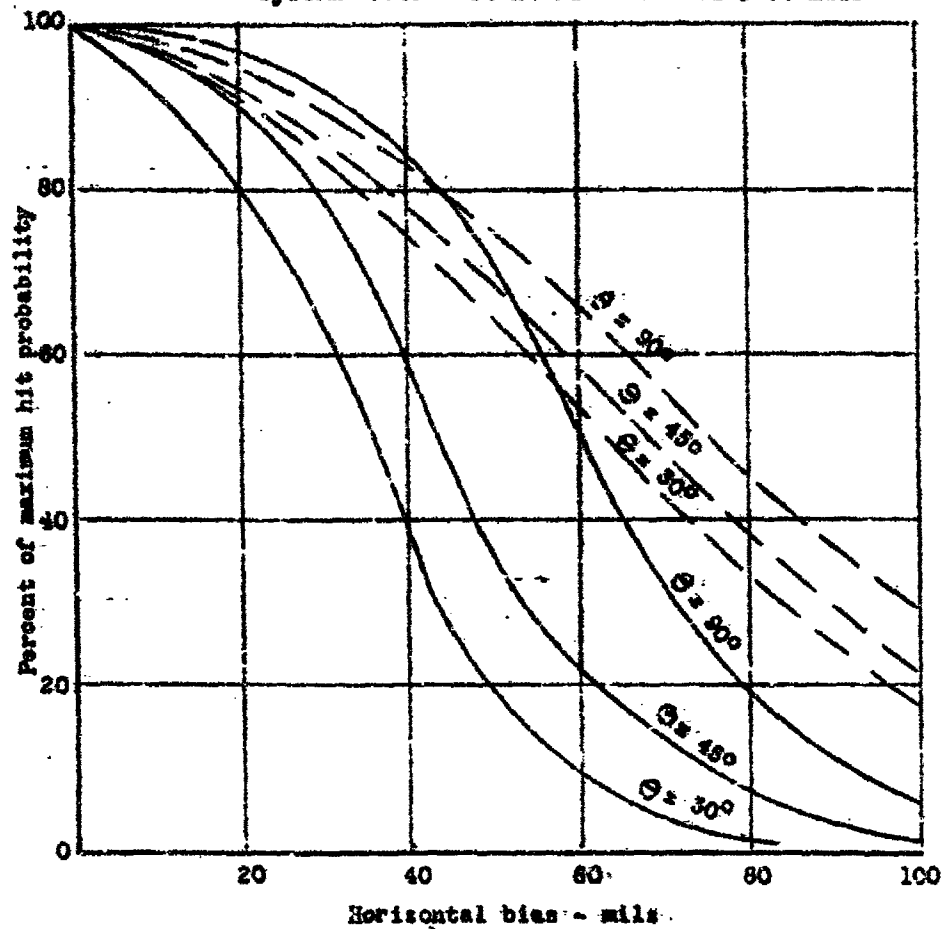

FIG. 16

VARIATION IN SINGLE SHOT HIT PROBABILITY
WITH TARGET ASPECT AND BIAS

SECRET

SECRET

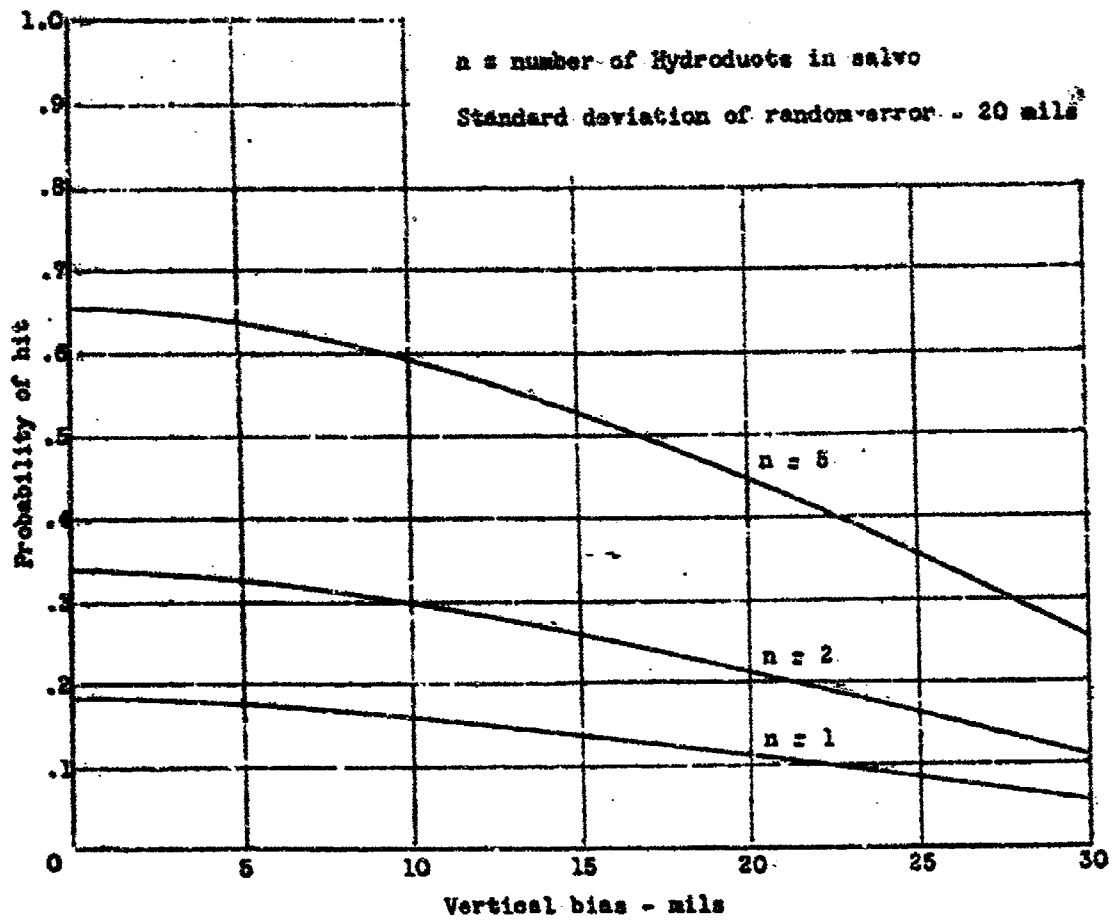

FIG. 15

VARIATION IN HIT PROBABILITY
WITH SALVO-SIZE AND BIAS

SECRET

SECRET

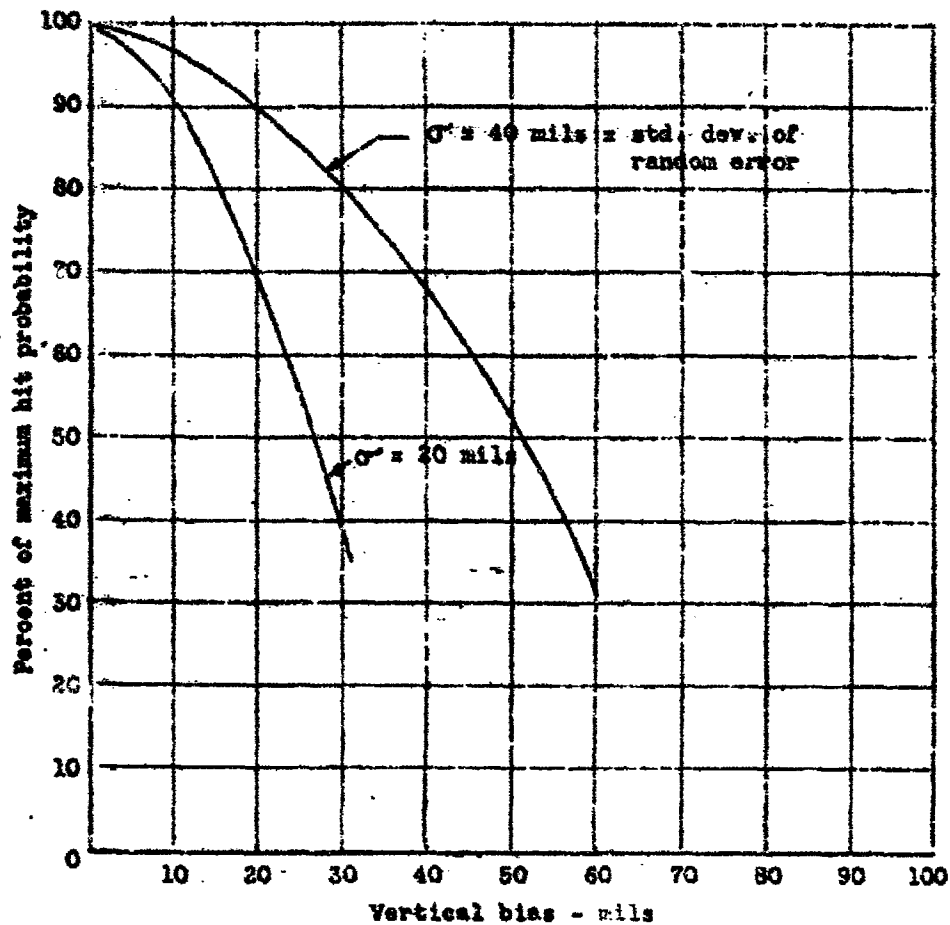

FIG. 20-

VARIATION IN HIT PROBABILITY WITH RANDOM ERROR AND BIAS
SALVO OF FIVE HYDRODUCTS

SECRET

SECRET

Θ = target aspect (angle off target bow or stern) - deg

Ballistic dispersion of Hydroduct ----- 8 mils

———— System error - standard deviation = 20 mils

- - - - System error - standard deviation = 50 mils

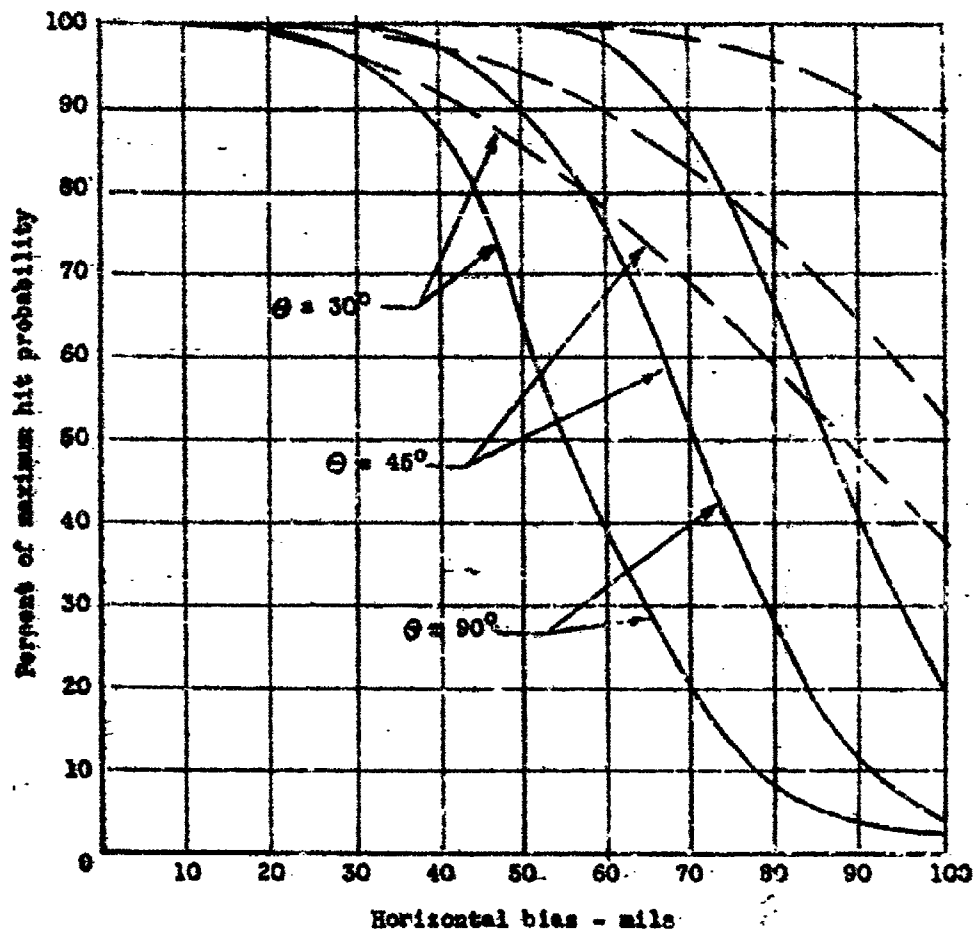

FIG. 21

VARIATION IN HIT PROBABILITY WITH TARGET ASPECT AND BIAS
SALVO OF FIVE HYDRODUCTS

SECRET

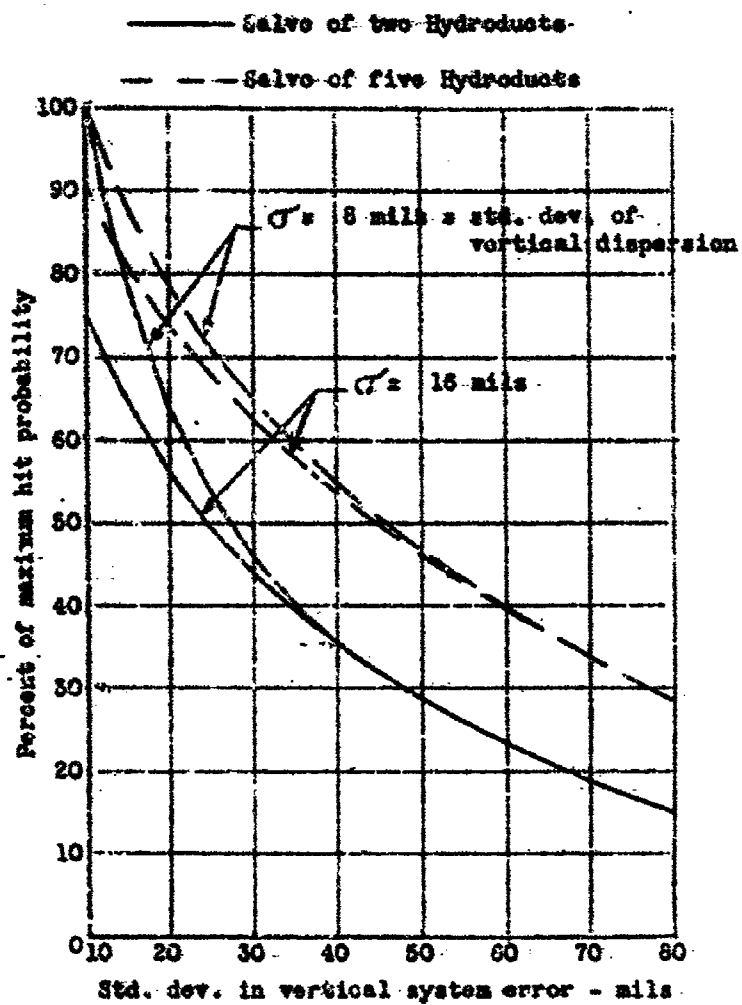

FIG. 22

VARIATION IN HIT PROBABILITY
WITH DISPERSION AND SYSTEM ERRORS

SECRET

REFERENCES

1. Summary of Submarine Characteristics, LAC Report No. 7242, Lockheed Aircraft Corporation, Burbank, California, 14 December 1949. (SECRET)
2. Analyses of the Relationship of Stability to Maneuverability in the Manual Control of Submarines, Robert R. Williamson and Bruen H. Peters, ETT Report No. 389, Stevens Institute of Technology, Hoboken, New Jersey, December 1949. (CONFIDENTIAL)
3. Model Study of the Submerged Lateral Turning Characteristics of the "Guppy" Conversion of the SS-475 Class Submarine, ETT Report No. 342, Stevens Institute of Technology, Hoboken, New Jersey, February 1948. (SECRET)
4. The Hydroduct Missile, Special Report 671, Aerojet Division of the General Tire and Rubber Company, Azusa, California, January 1953. (SECRET)
5. Free Running Underwater Launchings of the 4.5-in. Alclo Hydroduct Test Missile, U.S. NOTS TM 661, Underwater Ballistics Division, Underwater Ordnance Department, U.S. Naval Ordnance Test Station, Inyokern, China Lake, California, 27 June 1952. (SECRET)
6. Range Testing of the 4.5-in. Alclo Hydroduct, Reports No. L2815-1, L2815-2, and L2815-3, Informal Reports of Progress, Aerojet-General Corporation, Azusa, California, 12 May 1953, 2 June 1953, and 29 June 1953. (SECRET)
7. Fluid Dynamics, Summary Technical Report of Division 6, NDRC, Vol. 20, Washington, D.C., 1946. (CONFIDENTIAL)
8. Summary Progress Report, Multiple Launchings of the 5-in. Underwater Rocket NOTS Test Vehicle X-1, U.S. NOTS TM No. 695, Underwater Ballistics Division, Underwater Ordnance Department, U.S. Naval Ordnance Test Station, Inyokern, China Lake, California, 6 December 1952. (CONFIDENTIAL)
9. Probability of Success in Anti-Ship Attack with Submarine-Launched Rockets, EAG Report 135, Department of the Navy, Bureau of Ordnance, Washington 25, D.C., 3 October 1951. (SECRET)
10. Optimum Spacing of Bombs and Shots in the Presence of Systematic Errors, BRL Report No. 241, Ballistics Research Laboratory, Aberdeen Proving Ground, Maryland, May 1947. (CONFIDENTIAL)

SECRET

SECRET

11. Basis Concepts of the Theory of Probability as Applied to the Evaluation of Military Weapons, DR Report 1293, Navy Department, Bureau of Aeronautics, Washington 25, D.C., March 1951. (CONFIDENTIAL)
12. Probability and Statistical Studies in Warfare Analysis, Summary Technical Report of the Applied Mathematics Panel, NDRG, Vol. 3, Washington, D.C., 1946. (CONFIDENTIAL)
13. A Survey Report on Anti-Submarine Weapons Systems, Panel on Weapons Systems, Committee on Undersea Warfare, National Research Council, July 1950. (SECRET)

SECRET

BIBLIOGRAPHY

1. Research, Development, and Testing of Underwater Propulsion Devices, 1 March through 31 March 1951, Aerojet Report No. L800-55, Aerojet Engineering Corporation, Azusa, California, 11 April 1951. (CONFIDENTIAL)
2. Research, Development, and Testing of Underwater Propulsion Devices, 1 July through 31 December 1951, Aerojet Report No. 579, Aerojet Engineering Corporation, Azusa, California, 7 February 1952. (CONFIDENTIAL)
3. Research, Development, and Testing of Underwater Propulsion Devices, 1 January through 30 June 1952, Aerojet Report No. 631, Aerojet Engineering Corporation, Azusa, California, 12 August 1952. (CONFIDENTIAL)
4. Develop for Anti-Submarine Use, Underwater Weapons (Other than Torpedoes), and Their Launching and Fire Control Equipment, Capable of Inflicting Lethal Damage to a Submarine, Operational Requirement AS-07107, Chief of Naval Operations, Washington, D.C., 31 July 1953. (SECRET)
5. The Enemy Medium Speed Ocean Patrol Submarine of 1956, Lockheed Report No. 7667, Lockheed Aircraft Corporation, Burbank, California, 1 May 1951. (SECRET)
6. Possible Soviet Submarines of 1957 to 1962, Lockheed Report No. 8535, Lockheed Aircraft Corporation, Burbank, California, 14 November 1952. (SECRET)
7. Rocket and Underwater Ordnance, NDRC Div. 3, Vol. 1, Summary Technical Report of the National Defense Research Committee, Washington, D.C., 1946. (CONFIDENTIAL)
8. A Survey of Subsurface Warfare in World War II, NDRC Div. 6, Vol. 1, Summary Technical Report of the National Defense Research Committee, Washington, D.C., 1946. (SECRET)
9. Operations Research Methods, Div. 6, Vol. 2A, Summary Technical Report of the National Defense Research Committee, Washington, D.C., 1946. (CONFIDENTIAL)
10. A Theoretical Basis for Methods of Search and Screening, Div. 6, Vol. 2B, Summary Technical Report of the National Defense Research Committee, Washington, D.C., 1946. (CONFIDENTIAL)

SECRET

11. Sonar Listening Systems, Underwater Sound Equipment I, NDRC Div. 6, Vol. 14, Summary Technical Report of the National Defense Research Committee, Washington, D.C., 1946. (CONFIDENTIAL)
12. Sonar Echo-Ranging Systems, Underwater Sound Equipment II, NDRC Div. 6, Vol. 15, Summary Technical Report of the National Defense Research Committee, Washington, D.C., 1946. (CONFIDENTIAL)
13. ASW in World War II, OEG Report No. 51, Operations Evaluation Group, Office of the Chief of Naval Operations, Navy Department, Washington, D.C., 1946. (CONFIDENTIAL)
14. Underwater Explosion Research, Volume I - The Shock Wave, Office of Naval Research, Department of the Navy, Washington, D.C., 1950. (UNCLASSIFIED)
15. Underwater Performance of Sub-Caliber Anti-Submarine Training Rocket - Part I, Separation Tests, NOTS TM 569, R.H. Hornidge, U.S. Naval Ordnance Test Station, Inyokern, China Lake, California, 15 September 1951. (CONFIDENTIAL)
16. Blast Effects from Underwater Rocket Motors, NOTS TM 574, Thomas W. Layton, U.S. Naval Ordnance Test Station, Inyokern, China Lake, California, 12 September 1951. (CONFIDENTIAL)
17. Stability of High Speed Underwater Rockets, NOTS TM 611, James B. Kendrick, U.S. Naval Ordnance Test Station, Inyokern, China Lake, California, 14 January 1952. (CONFIDENTIAL)
18. Preliminary Investigation of High Speed, Unguided, Underwater Rockets, NOTS TM 808-46, D. J. Wilcox, U.S. Naval Ordnance Test Station, Inyokern, China Lake, California, 28 September 1950. (CONFIDENTIAL)
19. Feasibility Study of Unguided Rockets for Submarine to Surface Ship Application, NOTS TM 1226, R. C. Davis, U.S. Naval Ordnance Test Station, Inyokern, China Lake, California, March 1953. (SECRET)

SECRET

APPENDICES

<u>Appendix</u>		<u>Page</u>
I.	Initial Angle of Attack and Flight Path Angle with Rectilinear Motion of Launching Vehicle.	76
II.	Equations of Motion.	78
III.	Numerical Values.	87
IV.	Approximate Trajectory Equations	89
V.	Deceleration.	91
VI.	Tip-Off	92

APPENDIX I.

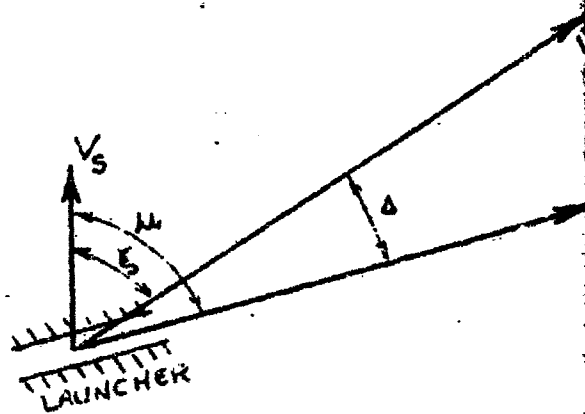
INITIAL ANGLE OF ATTACK AND FLIGHT PATH ANGLE
WITH RECTILINEAR MOTION OF LAUNCHER AND VEHICLE

$$\mu = \zeta + \Delta$$

$$\sin \Delta = \frac{V_S}{V_R} \sin \mu$$

$$\sin \zeta = \frac{V_M}{V_R} \sin \mu$$

$$V_R = \sqrt{V_S^2 + V_M^2 + 2V_S V_M \cos \mu}$$

where V_M = Hydroduct velocity relative to the launcher

V_S = launching vehicle velocity

V_R = relative velocity of the Hydroduct (flight path)

SECRET

In the vertical trajectory, if the launching vehicle velocity vector lies in a horizontal plane,

$\Delta = \alpha =$ angle of attack

$\mu = \theta =$ angle of Hydroduct reference axis } see Appendix II

$\xi = \gamma =$ flight path angle

and in the lateral trajectory,

$\Delta = \beta =$ angle of yaw

$\mu = \psi =$ angle of Hydroduct reference axis } see Appendix II

$\xi = \varphi =$ flight path angle

SECRET

APPENDIX II.
EQUATIONS OF MOTION

VERTICAL TRAJECTORY

For the purposes of this study, it is sufficient to consider the motion in the lateral plane and vertical plane separately and independently. With the additional assumptions that thrust equals drag and that the angle of attack is small the equations of motion in the vertical plane can be written as shown below with the assistance of the static force diagram of Fig. 1.

Basic Equations

$$-m\ddot{y} = -A_1\alpha + A_2\dot{\theta} + A_3 \dots \dots \dots (1)$$

$$I\ddot{\theta} = B_1\alpha + B_2\dot{\theta} + B_3 \dots \dots \dots (2)$$

where:

$$A_1 = -\frac{1}{2} \rho V^2 \frac{dC_L}{d\alpha} S + T$$

$$A_2 = -\frac{1}{2} \rho V \frac{dC_L}{d\alpha} S f_t$$

$$A_3 = (W - B) \cos \gamma$$

$$B_1 = \frac{1}{2} \rho V^2 \left[2Y(k_2 - k_1) - \frac{dC_L}{d\alpha} S f_t \right]$$

$$B_2 = -\frac{1}{2} \rho V \frac{dC_L}{d\alpha} S f_t^2$$

$$B_3 = -B f_b$$

$$\dot{\theta} = \dot{\gamma} + \dot{\alpha}$$

$$\ddot{\theta} = \ddot{\gamma} + \ddot{\alpha}$$

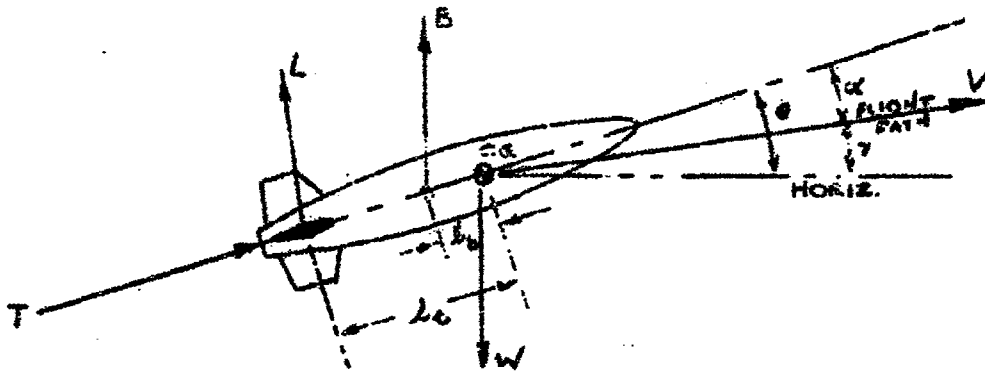

Fig. 1

Forces and moments in this set of equations are written in terms of a moving axis system with the x-axis initially pointing along the direction of the relative wind vector and the positive z-axis pointing down. In these expressions,

$$\frac{dC_L}{d\alpha} = \text{lift curve slope of the tail based on frontal area of the body}$$

$$S = \text{projected frontal area of body, ft}^2$$

$$T = \text{thrust, lb}$$

$$V = \text{volume, ft}^3$$

$$B = \text{buoyancy, lb}$$

$$\rho = \text{mass density of sea water, slugs/ft}^3$$

$$W = \text{weight, lb}$$

$$m = \text{total mass} \approx \frac{W + B}{g} \text{ (includes virtual mass), slugs}$$

$$I = \text{total moment of inertia} \approx I_G + I_v k', \text{ slug ft}^2$$

$$I_v = \text{virtual inertia; } k' \approx .84$$

k_1 = coefficient of apparent mass for longitudinal motion*

k_2 = coefficient of apparent mass for lateral motion*

M_f = coefficient of body upsetting moment = $\frac{1}{2} \rho V^2 [2V(k_2 - k_1)]$, lb ft

and the remaining items are defined in Appendix I and Figs. 1 and 2.

Transient in Angle of Attack

With constant mass, inertia, and speed, Eqs. (1) and (2) result in the following:

$$\alpha + \left[-\frac{A_1}{mV} - \frac{B_2}{I} \right] \dot{\alpha} + \left[-\frac{B_1}{I} \left(1 + \frac{A_2}{mV} \right) + \frac{B_2 A_1}{I mV} \right] \alpha + \frac{B_2 A_3}{I mV} - \frac{B_3}{I} \left(1 + \frac{A_2}{mV} \right) = 0$$

This is of form $\ddot{\alpha} + 2\zeta\omega_n\dot{\alpha} + \omega_n^2\alpha = \omega_n^2 C_3$

the solution of which is:

$$\alpha(t) = e^{-\zeta\omega_n t} \left[C_1' e^{\omega_n \sqrt{\zeta^2 - 1} t} + C_2' e^{-\omega_n \sqrt{\zeta^2 - 1} t} \right] + C_3$$

C_1' and C_2' are evaluated from initial conditions.

Case I: With cross-current conditions, but no angular velocity at launching,

$$\alpha(t=0) = \alpha_0$$

$$\dot{\alpha}(t=0) = 0$$

Therefore, $\alpha(t=0) = \alpha_0 = -\dot{\alpha}_0 = \frac{A_1}{mV} \alpha_0 + \frac{A_3}{mV}$

*Horace Lamb, Hydrodynamics. New York: Dover Publications, Inc., 1945, page 155.

SECRET

and

$$C_1' = \alpha_0 \left[1 - \frac{\left(\frac{\Lambda_1}{mV} - \lambda_1 \right)}{\lambda_2 - \lambda_1} \right] - \left[\frac{\frac{\Lambda_3}{mV} + \lambda_2 C_3}{\lambda_2 - \lambda_1} \right]$$

$$C_2' = \alpha_0 \left[\frac{\frac{\Lambda_1}{mV} - \lambda_1}{\lambda_2 - \lambda_1} \right] + \left[\frac{\frac{\Lambda_3}{mV} + \lambda_1 C_3}{\lambda_2 - \lambda_1} \right]$$

where

$$\lambda_1 = -\zeta\omega_n + \omega_n \sqrt{\zeta^2 - 1}$$

$$\lambda_2 = -\zeta\omega_n - \omega_n \sqrt{\zeta^2 - 1}$$

$$2\zeta\omega_n = -\frac{\Lambda_1}{mV} - \frac{B_2}{I}$$

$$\omega_n = \left[-\frac{B_1}{I} \left(1 + \frac{\Lambda_2}{mV} \right) + \frac{B_2 \Lambda_1}{I mV} \right]^{1/2}$$

$$C_3 = \frac{-\frac{B_2 \Lambda_3}{I mV} + \frac{B_3}{I} \left(1 + \frac{\Lambda_2}{mV} \right)}{\omega_n^2}$$

C_3 is the steady-state angle of attack.

Case II: If $\delta(t=0)$ is not zero, as for the case of a maneuvering launching submarine or when tip-off is present,

$$\alpha(t=0) = \alpha_0$$

$$\delta(t=0) = \delta_0$$

$$\delta_0 = \alpha_0 + \gamma_0$$

and

$$-\gamma_0 = \frac{\Lambda_1 \alpha_0 + \Lambda_2 \delta_0 + \Lambda_3}{mV}$$

Therefore

$$\alpha_0 = \left(1 + \frac{\Lambda_2}{mV} \right) \delta_0 + \frac{\Lambda_1}{mV} \alpha_0 + \frac{\Lambda_3}{mV}$$

$$C_1' = \alpha_0 \left[1 - \frac{\left(\frac{\Lambda_1}{mV} - \lambda_1 \right)}{\lambda_2 - \lambda_1} \right] - \left[\frac{1 + \frac{\Lambda_2}{mV}}{\lambda_2 - \lambda_1} \right] \delta_0 - \left[\frac{\frac{\Lambda_3}{mV} + \lambda_2 C_3}{\lambda_2 - \lambda_1} \right]$$

SECRET

$$C_2' = \alpha_0 \left[\frac{\frac{A_1}{mV} - \lambda_1}{\lambda_2 - \lambda_1} \right] + \left[\frac{1 + \frac{A_2}{mV}}{\lambda_2 - \lambda_1} \right] \dot{\theta}_0 + \left[\frac{\frac{A_3}{mV} + \lambda_1 C_3}{\lambda_2 - \lambda_1} \right]$$

SECRET

Transient in Flight Path Angle

The resulting transient in flight path angle, γ , obtained from integrating Eq. (1) is for Case I,

$$\begin{aligned} \gamma - \gamma_0 = & -\frac{1}{mV + A_2} \left\{ \left[\left(\frac{A_1}{\lambda_1} + A_2 \right) C_1' e^{\lambda_1 t} + \left(\frac{A_1}{\lambda_2} + A_2 \right) C_2' e^{\lambda_2 t} \right. \right. \\ & \left. \left. + (A_1 C_3 + A_3) t \right\} - \left[\left(\frac{A_1}{\lambda_1} + A_2 \right) C_1' + \left(\frac{A_1}{\lambda_2} + A_2 \right) C_2' \right] \end{aligned}$$

For large "t",

$$\gamma - \gamma_0 = -\frac{(A_1 C_3 + A_3)}{mV + A_2} t + \frac{\left(\frac{A_1}{\lambda_1} + A_2 \right) C_1' + \left(\frac{A_1}{\lambda_2} + A_2 \right) C_2'}{mV + A_2}$$

The coefficient of the first term represents the rate of change of flight path angle. From this expression it can be seen that the downward curvature of the flight path, which represents trajectory drop-off, decreases with increased net buoyancy and increased steady state angle of attack. Thus, low density vehicles with relatively low static stability will exhibit the flattest vertical trajectories. In these expressions C_1' and C_2' are the same as those shown in the transient for angle of attack.

For Case II when $\dot{\theta}(t=0) \neq 0$, the values of C_1' and C_2' will reflect the initial condition of $\dot{\theta}(t=0) = \dot{\theta}_0$ in accordance with the earlier discussion concerning the transient in angle of attack.

SECRET

LATERAL TRAJECTORY

SECRET

The lateral equations of motion can similarly be set up in terms of the diagram of Fig. 2. In this case, the space reference axis from which ψ and β are measured is conveniently taken as the velocity vector of the launcher at the instant of launching. The approximate equations for small yaw are then as follows:

Basic Equations

$$mV\dot{\phi} = K_1\beta + K_2\dot{\psi} \dots \dots \dots (3)$$

$$I\ddot{\psi} = C_1\beta + C_2\dot{\psi} \dots \dots \dots (4)$$

where

$$K_1 = \frac{1}{2} \rho V^2 \frac{dC_L}{d\alpha} S$$

$$K_2 = \frac{1}{2} \rho V \frac{dC_L}{d\alpha} S l_t$$

$$C_1 = \frac{1}{2} \rho V^2 \left[2Y(k_2 - k_1) - \frac{dC_L}{d\alpha} S l_t \right]$$

$$C_2 = -\frac{1}{2} \rho V \frac{dC_L}{d\alpha} S l_t^2$$

$$\dot{\psi} = \dot{\beta} + \dot{\phi}$$

$$\ddot{\psi} = \ddot{\beta} + \ddot{\phi}$$

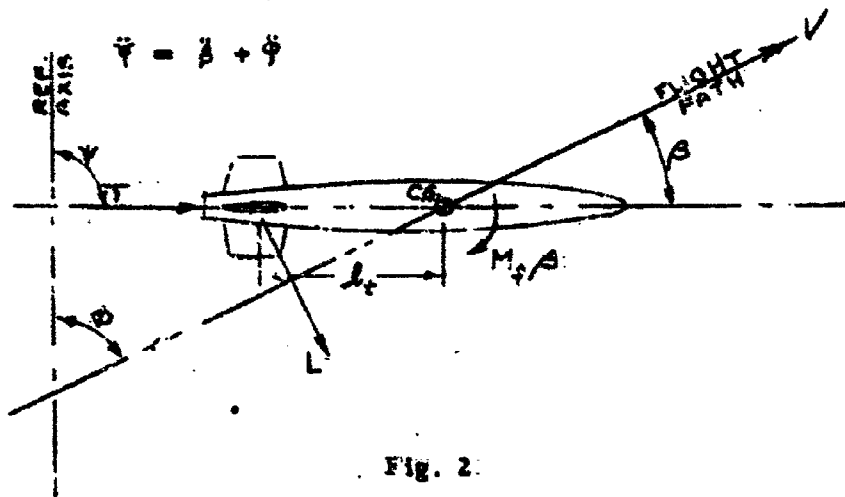

Fig. 2.

SECRET

Transient in Angle of Yaw

With constant speed, mass, and inertia, the differential equation in yaw is

$$\ddot{\beta} + \left[\frac{K_1}{mV} - \frac{C_2}{I} \right] \dot{\beta} + \left[-\frac{C_1}{I} \left(1 - \frac{K_2}{mV} \right) - \frac{C_2}{I} \frac{K_1}{mV} \right] \beta = 0$$

and the transient,

$$\beta(t) = e^{-\zeta \omega_n t} \left[C_1'' e^{\omega_n \sqrt{\zeta^2 - 1} t} + C_2'' e^{-\omega_n \sqrt{\zeta^2 - 1} t} \right]$$

Case I: With cross current conditions, but no angular velocity at launching,

$$\beta(t=0) = \beta_0$$

$$\dot{\beta}(t=0) = 0$$

$$\dot{\beta}_0 = -\dot{\beta}_0 = -\frac{K_1}{mV} \beta_0$$

$$C_1'' = \beta_0 \left[1 - \frac{\left(-\frac{K_1}{mV} - \lambda_1 \right)}{\lambda_2 - \lambda_1} \right]$$

$$C_2'' = \beta_0 \left[\frac{-\frac{K_1}{mV} - \lambda_1}{\lambda_2 - \lambda_1} \right] = 1 - C_1''$$

Case II: If $\dot{\beta}(t=0)$ is not zero, as for the case of a maneuvering launching submarine or when tip-off is present,

$$\beta(t=0) = \beta_0$$

$$\dot{\beta}(t=0) = \dot{\beta}_0$$

SECRET

$$\dot{\beta}_0 = -\dot{\phi}_0 = -\frac{K_1}{mV} \beta_0 + \left(1 - \frac{K_2}{mV}\right) \dot{\psi}_0$$

$$C_1'' = \beta_0 \left[1 - \frac{\left(-\frac{K_1}{mV} - \lambda_1\right)}{\lambda_2 - \lambda_1} \right] - \left[\frac{\left(1 - \frac{K_2}{mV}\right) \dot{\psi}_0}{\lambda_2 - \lambda_1} \right]$$

$$C_2'' = \beta_0 \left[\frac{-\frac{K_1}{mV} - \lambda_1}{\lambda_2 - \lambda_1} \right] + \left[\frac{\left(1 - \frac{K_2}{mV}\right) \dot{\psi}_0}{\lambda_2 - \lambda_1} \right]$$

Transient in Flight Path Angle

Integration of Eq. (3) gives for the flight path angle,

$$\begin{aligned} \phi - \phi_0 = & \frac{1}{mV - K_2} \left\{ \left(\frac{K_1}{\lambda_1} + K_2 \right) C_1'' e^{\lambda_1 t} + \left(\frac{K_1}{\lambda_2} + K_2 \right) C_2'' e^{\lambda_2 t} \right. \\ & \left. - \left(\frac{K_1}{\lambda_1} + K_2 \right) C_1'' - \left(\frac{K_1}{\lambda_2} + K_2 \right) C_2'' \right\} \end{aligned}$$

DISPERSION

Bent fins or misalignment act as forcing terms in the equations of motion. As an illustration, for the lateral plane motion,

$$mV\dot{\phi} = K_1\alpha + K_2\dot{\beta} + K_4\delta \sin \omega t$$

$$I\ddot{\beta} = C_1\alpha + C_2\dot{\beta} + C_4\delta \sin \omega t$$

where δ is some acceptable statistic of the distribution of misalignment or bending, and ω is the frequency of rotation of the Hydroduct about its axis of symmetry.

This results in a sinusoidal forcing function in the differential equation for angle of yaw:

SECRET

SECRET

$$\ddot{\beta} + 2\zeta\omega_n \dot{\beta} + \omega_n^2 \beta = C_5 \sin \omega t$$

and

$$\beta(t) = m_1 e^{\lambda_1 t} + m_2 e^{\lambda_2 t} + \left[\frac{C_5 \sin(\omega t - \gamma)}{\sqrt{(\omega_n^2 - \omega^2)^2 + 4\zeta^2 \omega_n^2 \omega^2}} \right]$$

The last term represents the steady state value of β , since all other terms die out exponentially. The coefficient in brackets in this steady state term should be small for the Hydroduct for reasonable values of ω , since the vehicle is well damped and ω_n is inherently large. Experiments on test versions appear to bear out the fundamentally low dispersion characteristics of the Hydroduct as far as symmetrical dispersions are concerned.

A rather large source of dispersion appears to be the result of random differences in thrust between Hydroducts during the test run. This would have the effect of essentially varying the equilibrium speed from one vehicle to the next, and would result mainly in dispersions in the vertical direction. Some secondary effect on symmetrical dispersions might be expected from variations in the values of ω_n and ζ in the steady state dispersion term which would result from variations in equilibrium speed.

m_1 and m_2 can be shown to consist of initial condition terms and terms containing δ which are independent of one another. Hence, the initial conditions in themselves would not be expected to contribute directly to dispersion. However, as pointed out above, if initial conditions result in deviations that might produce changes in the characteristic motion of the vehicle, dispersions from manufacturing tolerances or handling damage may be altered.

SECRET

APPENDIX III.
NUMERICAL VALUES

Values of the constants appearing in the equations given in Appendix II are estimated to be as follows:

$\frac{dC_L}{d\alpha}$	6.43 per rad
S441 ft ²
L_t	2.6 ft
W	$\begin{matrix} 215 \text{ lb (unburned)} \\ 115 \text{ lb (burned)} \end{matrix}$
B	112.7 lb
V	1.762 ft ³
k_1029
k_2945
t_b20 ft

At the launching speed of 250 feet-per-second (unburned);

$$A_1 = -K_1 = -178,000 \text{ lb}$$

$$A_2 = -K_2 = -1845 \text{ lb sec}$$

$$A_3 = 102 \text{ lb}$$

$$B_1 = C_1 = -259,000 \text{ lb ft}$$

$$B_2 = C_2 = -4,790 \text{ lb ft sec}$$

$$B_3 = -22.5 \text{ lb ft}$$

$$I = 17.6 \text{ slug ft}^2 \text{ (including virtual inertia)}$$

$$m = 10 \text{ slugs (including virtual mass)}$$

SECRET

With these values the damping ratio, ζ , is approximately 1.1 and the undamped natural frequency, ω_n , is approximately 25 cycles per second. The roots of the characteristic equation are $\lambda_1 = -93$ and $\lambda_2 = -249$. The steady state angle of attack, C_3 , is approximately .00047 radians. In the burned condition (15 seconds) at the speed of 250 feet per second,

$$W \approx 132 \text{ lb}$$

$$\omega_n = 30 \text{ cps}$$

$$m \approx 7.6 \text{ slugs}$$

$$\lambda_1 = -89$$

$$I \approx 12.9 \text{ slug} \cdot \text{ft}^2$$

$$\lambda_2 = -376$$

$$\zeta = 1.24$$

$$C_3 = .00056 \text{ radians}$$

At a speed of 150 feet per second ($d = 300 \text{ ft}$),

$$A_1 \approx -64,000 \text{ lb}$$

$$B_1 = -93,300 \text{ lb ft}$$

$$A_2 \approx -1,108 \text{ lb sec}$$

$$B_2 = -2,680 \text{ lb ft sec}$$

In the burned condition,

$$\zeta = 1.24$$

$$\lambda_1 = -57$$

$$\omega_n = 18 \text{ cps}$$

$$\lambda_2 = -223$$

$$C_3 = .00158 \text{ radians}$$

SECRET

SECRET

APPENDIX IV.

APPROXIMATE TRAJECTORY EQUATIONS.

With the assumption of a very flat trajectory, the equations of motion in the vertical plane have been developed in References 4 and 5 into convenient expressions for the vertical trajectory of the form:

$$\ddot{y} = g g^*(W)$$

$$\dot{z} = V \cos \gamma$$

where
$$g^*(W) = \frac{(1 - \varphi')(1 - \lambda') + \delta'}{(1 - \varphi)(1 + k_1 \delta') + \delta'(k_2 - k_1)}$$

$$\delta' = \frac{B}{W}$$

$$\lambda = \frac{k_2}{k_1}$$

$$\varphi' = \frac{2V(k_2 - k_1)}{S k_t \left(\frac{dC_L}{d\alpha} \right)}$$

These items, and hence g^* , will vary with the weight as fuel is burned. With a burning rate of about 5.5 pounds per second, which corresponds to a total burning time of about 16 seconds, the expression for g^* becomes:

$$g^*(t) \approx .284 - .0098t - .000133t^2 = \frac{\dot{y}}{g}$$

Integrating twice,

$$y = V_0 \sin \gamma t - g(.142t^2 - .00163t^3 - .000011t^4)$$

where γ = angle of elevation of the flight path at the beginning of the trajectory

SECRET

SECRET

The value of V is a function of depth and also of any deceleration which takes place after launching. Hence, a stepwise integration is required in establishing the trajectory.

SECRET

APPENDIX V.
 DECELERATION

The approximate force equation along the direction of the x-axis of Fig. 1 is:

$$m\dot{V} = T - D$$

The variation of thrust and drag with speed for the Hydroduct is illustrated in Fig. 3 on page 13. This figure indicates that thrust varies approximately as the speed, and drag varies approximately as the square of the speed at any given depth. Drag due to angle of attack and other higher order effects are negligible for all practical purposes. Hence, the above expression can be approximated in the form

$$m\dot{V} = L_1 V + L_2 V^2$$

where $L_1 = \frac{T}{V}$ and $L_2 = -\frac{D_0}{V^2}$

These are constant at any fixed depth. When integrated, this expression gives at any depth,

$$V = \frac{L_1 V_0 e^{(L_1 t/m)}}{L_1 + L_2 V_0 (1 - e^{(L_1 t/m)})}$$

V = final speed

V_0 = initial speed

At 300 feet depth, $L_1 \approx 5.0$ and $L_2 \approx -.033$. Using these values, approximately eight seconds are required to decelerate from an initial relative speed at launching of 270 feet per second to the equilibrium speed for that depth of 150 feet per second. Deceleration to 250 feet per second at 40 feet depth requires about four seconds. These same values hold also for the case of the lateral trajectory.

APPENDIX VI.

TIP-OFF

The approximate equations of vertical plane motion relative to an axis system fixed with respect to the launcher, and with the origin at the center of gravity of the Hydroduct at the instant the maximum diameter passes the lip of the launcher, can be written:

$$m\ddot{y} = (W - B) \cos \theta_0 - R - L + A_2 \dot{\theta}_1 \dots \dots \dots (1)$$

$$I\ddot{\theta}_1 = M_f \alpha - B_2 \dot{\theta}_1 - B_2 \theta_0 - R l_t - L l_b \dots \dots \dots (2)$$

where R = launcher motion

$$M_f \alpha = \text{body upsetting moment} = \frac{1}{2} \rho V^2 [2V (k_2 - k_1)]$$

θ_0 = initial angle of elevation of the launcher

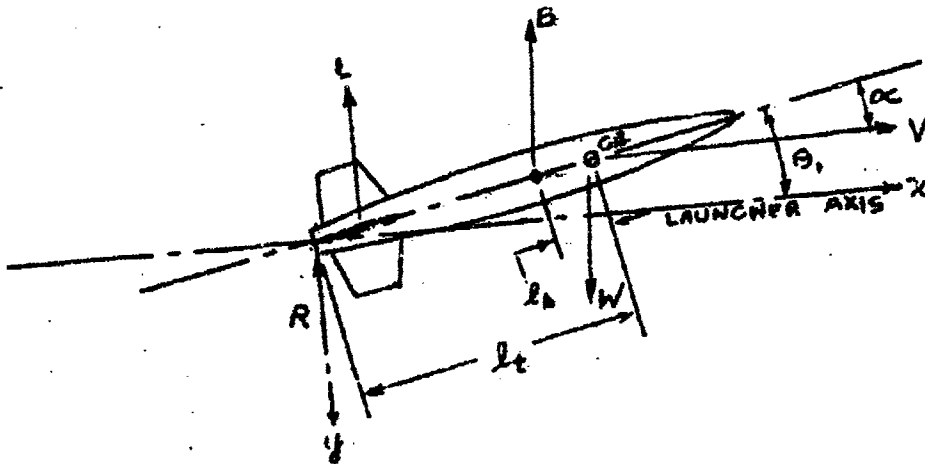

Fig. 3

With the assumptions that (1) the rear of the vehicle is supported to move along the axis of the launcher, (2) the y-coordinate of the point of support does not change (rigid launcher), and (3) no support is provided by the lip of the launcher once the maximum diameter of the Hydroduct passes it, the condition of constraint becomes:

$$y = -l_t \theta_1$$

With these conditions and assumptions, the equations can be combined to give:

$$[1 - ml_t^2] \ddot{\theta}_1 + [A_2 - B_2] \dot{\theta}_1 = (-W+B) l_t \cos \theta_0 - M l_t \alpha_0 - B l_t \dot{\theta}_0 \dots (3)$$

Assuming that the increment-in-angle of attack developed at the center of gravity during launching is small, $\alpha \approx \alpha_0$, which is a known effect of cross stream conditions at the launcher.

The solution of this equation is:

$$\theta_1(t) \approx \frac{[(-W+B) l_t \cos \theta_0 - M l_t \alpha_0 - B l_t \dot{\theta}_0] [1 - ml_t^2] \left[\frac{A_2 - B_2}{1 - ml_t^2} + \frac{A_2 - B_2}{1 + ml_t^2} t - 1 \right]}{[A_2 - B_2]^2}$$

$$\approx \frac{Z_2}{Z_1^2} [e^{-Z_1 t} + Z_1 t - 1]$$

and

$$\dot{\theta}_1 \approx \frac{Z_2}{Z_1} [1 - e^{-Z_1 t}]$$

For the Hydroduct in launching condition at a speed of 250 feet per second,

$$\theta_1 \approx -.000217 \cos \theta_0 - .000017 + .1505 \alpha_0 \dots \dots (4)$$

$$\dot{\theta}_1 \approx -.0339 \cos \theta_0 - .00259 + 23.3 \alpha_0 \dots \dots (5)$$

The first two terms in these equations are the effects of gravity tip-off alone. The last term is the hydrodynamic tip-off effect. For the conditions assumed

SECRET

here, the hydrodynamic tip-off effect will predominate at angles of elevation above about 1° , and can become quite large at high launcher elevation and launching-submarine speed.

In the lateral trajectory case, all of the gravity and buoyancy terms drop out, and only the hydrodynamic term remains. Thus, the tip-off effects for launching off the bow of a moving submarine will be more extreme than any occurring in the vertical plane.

The equations of motion for tip-off shown above are written with the assumption that hydrodynamic forces and moments are fully effective. This is probably quite conservative, since blanketing effects of the launcher would tend to have the effect of reducing the contribution of elements inside the launcher. Actually, the forces and moments are probably time-dependent as the vehicle leaves the launcher. Since there is no way to assess these effects at this time, they are not included in this analysis.

Also, the conditions of constraint may be altered by launcher design considerations, such as flexibility and clearances; however, again little is known about the launcher design at this time, and the conditions used in this analysis may not be representative of the final configuration.

The increment in angle of attack induced at the center of gravity by rotational velocities developed during tip-off is approximately $-\theta \dot{\theta}_t / V$. Neglecting this increment during tip-off introduces errors of the order of about 10% in θ and $\dot{\theta}$ which, in view of the other assumptions and approximations used, are for all practical purposes negligible. The actual increment in angle of attack should be included in the initial angle of attack for the transient period following tip-off.

A more exact solution could be obtained by a step-by-step integration of Eq. (3) over short time intervals during the tip-off.

SECRET

SECRET

<u>Addresses</u>	<u>No. of Copies</u>
Commanding Officer Office of Naval Research Branch Office 1030 East Green Street Pasadena 1, California	1
Commanding Officer Office of Naval Research Branch Office John Crerar Library Building 26 East Randolph Street Chicago 1, Illinois	1
Commanding Officer Office of Naval Research Branch Office 346 Broadway New York 13, New York	1
Commanding Officer Office of Naval Research Branch Office 1000 Geary Street San Francisco 9, California	1
Commander, Submarine Force U. S. Pacific Fleet c/o Fleet Post Office San Francisco, California	1
Commander, Submarine Force U. S. Atlantic Fleet c/o Fleet Post Office New York, New York	1
Commander Submarine Development Group TWC Box 70, U. S. Naval Submarine Base New London, Connecticut	1

SECRET

A-5097

SECRET

θ = target aspect (angle off target bow or stern) - deg
Ballistic dispersion of Hydrodoot ----- 8 mils
----- System error - standard deviation = 20 mils
----- System error - standard deviation = 50 mils

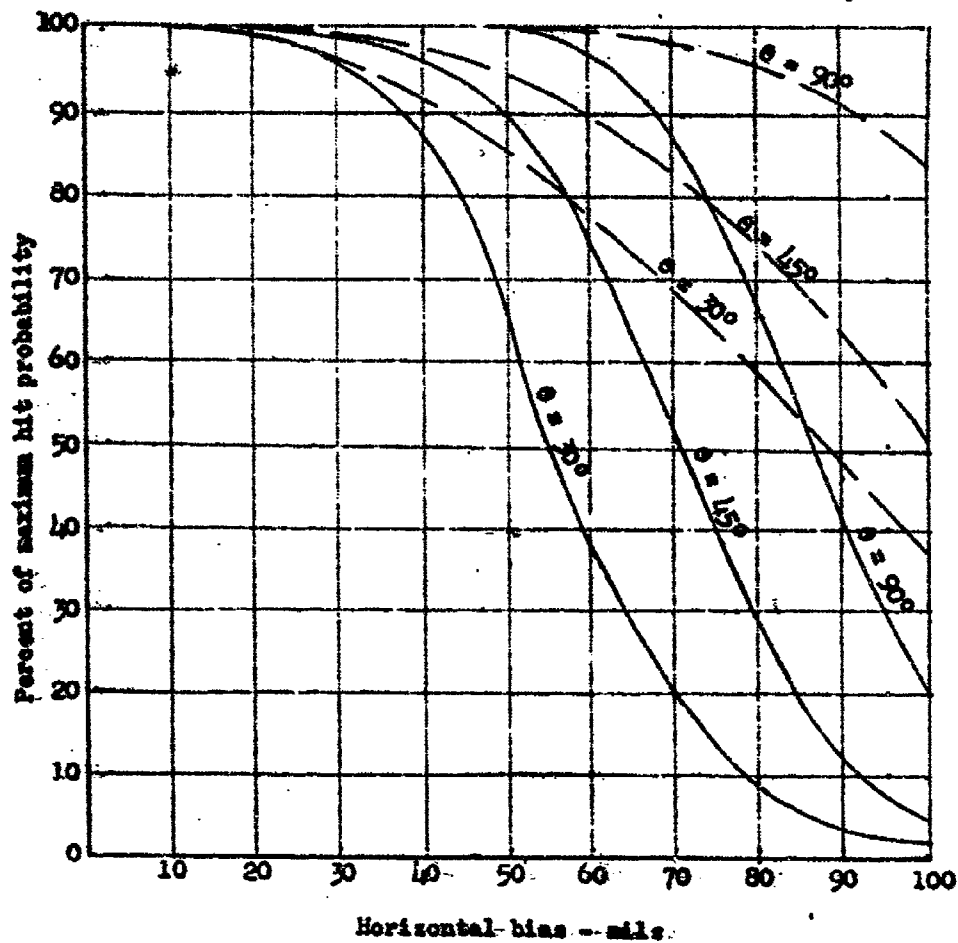

FIG. 21

VARIATION IN HIT PROBABILITY WITH TARGET ASPECT AND BIAS
SALVO OF FIVE HYDRODOOTS

SECRET

APPENDICES

<u>Appendix</u>	<u>Page</u>
I. Initial Angle of Attack and Flight Path Angle with Rectilinear Motion of Launching Vehicle.	76
II. Equations of Motion	78
III. Numerical Values	87
IV. Approximate Trajectory Equations	89
V. Deceleration	91
VI. Tip-Off	92

APPENDIX I.

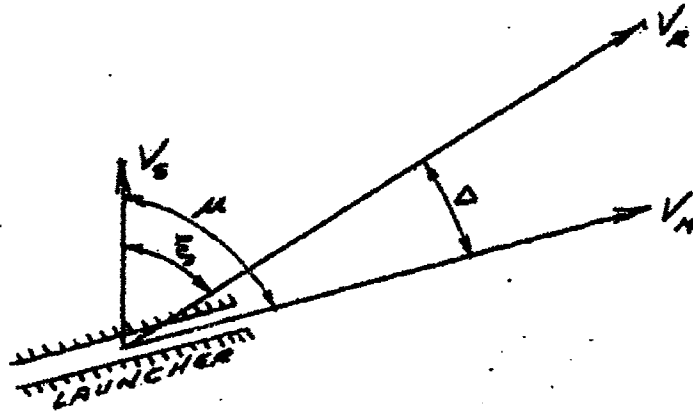
INITIAL ANGLE OF ATTACK AND FLIGHT PATH ANGLE
WITH RECTILINEAR MOTION OF LAUNCHING VEHICLE

$$\mu = \zeta + \Delta$$

$$\sin \Delta = \frac{V_S}{V_R} \sin \mu$$

$$\sin \zeta = \frac{V_M}{V_R} \sin \mu$$

$$V_R = \sqrt{V_S^2 + V_M^2 + 2V_S V_M \cos \mu}$$

where: V_M = Hydroduct velocity relative to the launcher

V_S = launching vehicle velocity.

V_R = relative velocity of the Hydroduct (flight path)

SECRET

In the vertical trajectory, if the launching vehicle velocity vector lies in a horizontal plane,

$\Delta = \alpha =$ angle of attack

$\mu = \theta =$ angle of Hydroduct reference axis

$\xi = \gamma =$ flight path angle

see Appendix II

and in the lateral trajectory,

$\Delta = \beta =$ angle of yaw

$\mu = \psi =$ angle of Hydroduct reference axis

$\xi = \phi =$ flight path angle

see Appendix II

SECRET

APPENDIX II.

EQUATIONS OF MOTION

VERTICAL TRAJECTORY

For the purposes of this study, it is sufficient to consider the motion in the lateral plane and vertical plane separately and independently. With the additional assumptions that thrust equals drag and that the angle of attack is small, the equations of motion in the vertical plane can be written as shown below with the assistance of the static force diagram of Fig. 1.

Basic Equations

$$-mV\dot{\gamma} = A_1\alpha + A_2\dot{\theta} + A_3 \dots \dots \dots (1)$$

$$I\ddot{\theta} = B_1\alpha + B_2\dot{\theta} + B_3 \dots \dots \dots (2)$$

where

$$A_1 = -\frac{1}{2} \rho v^2 \frac{dC_L}{d\alpha} S \cdot T$$

$$A_2 = -\frac{1}{2} \rho v \frac{dC_L}{d\alpha} S \dot{\alpha}_t$$

$$A_3 = (W - B) \cos \gamma$$

$$B_1 = \frac{1}{2} \rho v^2 \left[2Q(k_2 - k_1) - \frac{dC_L}{d\alpha} S \dot{\alpha}_t \right]$$

$$B_2 = -\frac{1}{2} \rho v \frac{dC_L}{d\alpha} S \dot{\alpha}_t^2$$

$$B_3 = -B \dot{\alpha}_t$$

$$\dot{\theta} = \dot{\gamma} + \dot{\alpha}$$

$$\ddot{\theta} = \ddot{\gamma} + \ddot{\alpha}$$

SECRET

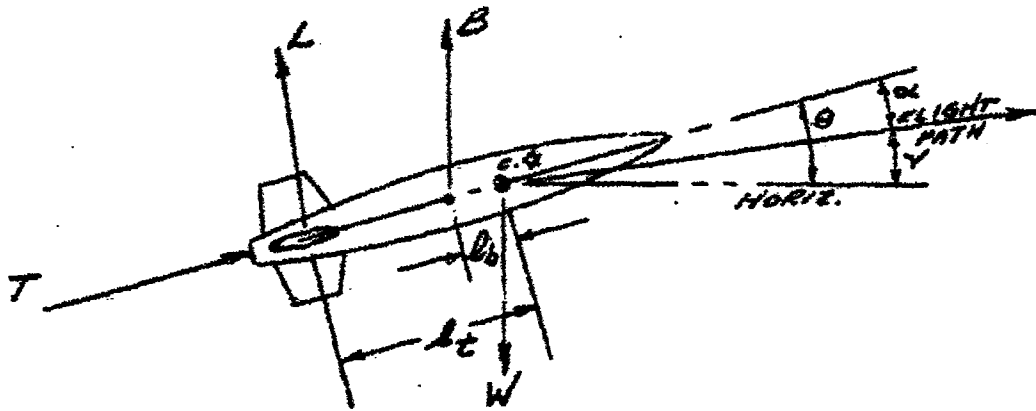

Fig. 1

Forces and moments in this set of equations are written in terms of a moving axis system with the x-axis initially pointing along the direction of the relative wind vector and the positive z-axis pointing down. In these expressions,

$\frac{dC_L}{d\alpha}$ = lift curve slope of the tail based on frontal area of the body

S = projected frontal area of body, ft²

T = thrust, lb

Q = volume, ft³

B = buoyancy, lb

ρ = mass density of sea water, slugs/ft³

W = weight, lb

m = total mass $\cong \frac{W + B}{g}$ (includes virtual mass), slugs

I = total moment of inertia $\cong I_G + I_v k^2$, slug ft²

I_v = virtual inertia; $k^2 \cong .24$

SECRET

SECRET

k_1 = coefficient of apparent mass for longitudinal motion*

k_2 = coefficient of apparent mass for lateral motion*

M_f = coefficient of body upsetting moment = $\frac{1}{2} \rho V^2 [2Q(k_2 - k_1)]$, lb ft

and the remaining items are defined in Appendix I and Figs. 1 and 2.

Transient in Angle of Attack

With constant mass, inertia, and speed, Eqs. (1) and (2) result in the following:

$$\ddot{\alpha} + \left[-\frac{A_1}{mV} - \frac{B_2}{I} \right] \dot{\alpha} + \left[-\frac{B_1}{I} \left(1 + \frac{A_2}{mV} \right) + \frac{B_2}{I} \frac{A_1}{mV} \right] \alpha + \frac{B_2}{I} \frac{A_3}{mV} - \frac{B_3}{I} \left(1 + \frac{A_2}{mV} \right) = 0$$

This is of form $\ddot{\alpha} + 2\zeta\omega_n\dot{\alpha} + \omega_n^2\alpha = \omega_n^2 C_3$, the solution of which is

$$\alpha(t) = e^{-\zeta\omega_n t} \left[C_1' e^{\omega_n \sqrt{\zeta^2 - 1} t} + C_2' e^{-\omega_n \sqrt{\zeta^2 - 1} t} \right] + C_3$$

C_1' and C_2' are evaluated from initial conditions.

Case I: With cross current conditions, but no angular velocity at launching,

$$\alpha(t=0) = \alpha_0$$

$$\dot{\alpha}(t=0) = 0$$

Therefore, $\dot{\alpha}(t=0) = -\dot{\gamma}_0 = \frac{A_1}{mV} \alpha_0 + \frac{A_3}{mV}$

*Horace Lamb, Hydrodynamics. New York: Dover Publications, Inc., 1945, page 155.

SECRET

SECRET

$$\text{and } C_1' = \alpha_0 \left[1 - \frac{\left(\frac{A_1}{mV} - \lambda_1\right)}{\lambda_2 - \lambda_1} \right] - \left[\frac{\frac{A_3}{mV} + \lambda_2 C_3}{\lambda_2 - \lambda_1} \right]$$

$$C_2' = \alpha_0 \left[\frac{\frac{A_1}{mV} - \lambda_1}{\lambda_2 - \lambda_1} \right] + \left[\frac{\frac{A_3}{mV} + \lambda_1 C_3}{\lambda_2 - \lambda_1} \right]$$

$$\text{where } \lambda_1 = -\zeta\omega_n + \omega_n \sqrt{\zeta^2 - 1}$$

$$\lambda_2 = -\zeta\omega_n - \omega_n \sqrt{\zeta^2 - 1}$$

$$2\zeta\omega_n = -\frac{A_1}{mV} - \frac{B_2}{I}$$

$$\omega_n = \left[\frac{B_1}{I} \left(1 + \frac{A_2}{mV}\right) + \frac{B_2 A_1}{I mV} \right]^{1/2}$$

$$C_3 = \frac{-\frac{B_2 A_3}{I mV} + \frac{B_3}{I} \left(1 + \frac{A_2}{mV}\right)}{\omega_n^2}$$

C_3 is the steady state angle of attack.

Case II: If $\dot{\theta}(t=0)$ is not zero, as for the case of a maneuvering launching submarine or when tip-off is present,

$$\alpha(t=0) = \alpha_0$$

$$\dot{\gamma}(t=0) = \dot{\theta}_0$$

$$\dot{\theta}_0 = \dot{\alpha}_0 + \dot{\gamma}_0$$

and

$$-\dot{\gamma}_0 = \frac{A_1 \alpha_0 + A_2 \dot{\theta}_0 + A_3}{mV}$$

Therefore,

$$\dot{\alpha}_0 = \left(1 + \frac{A_2}{mV}\right) \dot{\theta}_0 + \frac{A_1}{mV} \alpha_0 + \frac{A_3}{mV}$$

SECRET

SECRET

$$C_1' = \alpha_0 \left[1 - \frac{\left(\frac{A_1}{mV} - \lambda_1\right)}{\lambda_2 - \lambda_1} \right] - \left[\frac{1 + \frac{A_2}{mV}}{\lambda_2 - \lambda_1} \right] \dot{\theta}_0 - \left[\frac{\frac{A_3}{mV} + \lambda_2 C_3}{\lambda_2 - \lambda_1} \right]$$

$$C_2' = \alpha_0 \left[\frac{\frac{A_1}{mV} - \lambda_1}{\lambda_2 - \lambda_1} \right] + \left[\frac{1 + \frac{A_2}{mV}}{\lambda_2 - \lambda_1} \right] \dot{\theta}_0 + \left[\frac{\frac{A_3}{mV} + \lambda_1 C_3}{\lambda_2 - \lambda_1} \right]$$

Transient in Flight Path Angle

The resulting transient in flight path angle, γ , obtained from integrating Eq. (1) is for Case I,

$$\begin{aligned} \gamma - \gamma_0 = & - \frac{1}{mV + A_2} \left\{ \left[\left(\frac{A_1}{\lambda_1} + A_2 \right) C_1' e^{\lambda_1 t} + \left(\frac{A_1}{\lambda_2} + A_2 \right) C_2' e^{\lambda_2 t} \right. \right. \\ & \left. \left. + (A_1 C_3 + A_3) t \right] - \left[\left(\frac{A_1}{\lambda_1} + A_2 \right) C_1' + \left(\frac{A_1}{\lambda_2} + A_2 \right) C_2' \right] \right\} \end{aligned}$$

For large "t",

$$\gamma - \gamma_0 = - \frac{(A_1 C_3 + A_3)}{mV + A_2} t + \frac{\left(\frac{A_1}{\lambda_1} + A_2 \right) C_1' + \left(\frac{A_1}{\lambda_2} + A_2 \right) C_2'}{mV + A_2}$$

The coefficient of the first term represents the rate of change of flight path angle. From this expression it can be seen that the downward curvature of the flight path, which represents trajectory drop-off, decreases with increased net buoyancy and increased steady state angle of attack. Thus, low density vehicles with relatively low static stability will exhibit the flattest vertical trajectories. In these expressions C_1' and C_2' are the same as those shown in the transient for angle of attack.

For Case II when $\dot{\theta}(t=0) \neq 0$, the values of C_1' and C_2' will reflect the initial condition of $\dot{\theta}(t=0) = \dot{\theta}_0$ in accordance with the earlier discussion concerning the transient in angle of attack.

SECRET

SECRET

Transient in Angle of Yaw

With constant speed, mass, and inertia, the differential equation in yaw is:

$$\ddot{\beta} + \left[\frac{K_1}{mV} - \frac{C_2}{I} \right] \dot{\beta} + \left[-\frac{C_1}{I} \left(1 - \frac{K_2}{mV} \right) - \frac{C_2 K_1}{I mV} \right] \beta = 0$$

and the transient,

$$\beta(t) = e^{-\zeta \omega_n t} \left[C_1'' e^{\omega_n \sqrt{1-\zeta^2} t} + C_2'' e^{-\omega_n \sqrt{1-\zeta^2} t} \right]$$

Case I: With cross current conditions, but no angular velocity at launching.

$$\beta(t=0) = \beta_0$$

$$\dot{\beta}(t=0) = 0$$

$$\lambda_0 = -\dot{\beta}_0 = -\frac{K_1}{mV} \beta_0$$

$$C_1'' = \beta_0 \left[1 - \frac{\left(-\frac{K_1}{mV} - \lambda_1 \right)}{\lambda_2 - \lambda_1} \right]$$

$$C_2'' = \beta_0 \frac{\left[-\frac{K_1}{mV} - \lambda_1 \right]}{\lambda_2 - \lambda_1} = 1 - C_1''$$

Case II: If $\dot{\beta}(t=0)$ is not zero, as for the case of a maneuvering launching submarine or when tip-off is present,

$$\beta(t=0) = \beta_0$$

$$\dot{\beta}(t=0) = \dot{\beta}_0$$

SECRET

$$\dot{\beta}_0 = -\dot{\varphi}_0 = -\frac{K_1}{mV} \beta_0 + \left(1 - \frac{K_2}{mV}\right) \dot{\psi}_0$$

$$C_1'' = \beta_0 \left[1 - \frac{\left(-\frac{K_1}{mV} - \lambda_1\right)}{\lambda_2 - \lambda_1} \right] - \left[\frac{\left(1 - \frac{K_2}{mV}\right) \dot{\psi}_0}{\lambda_2 - \lambda_1} \right]$$

$$C_2'' = \beta_0 \left[\frac{-\frac{K_1}{mV} - \lambda_1}{\lambda_2 - \lambda_1} \right] + \left[\frac{\left(1 - \frac{K_2}{mV}\right) \dot{\psi}_0}{\lambda_2 - \lambda_1} \right]$$

Transient in Flight Path Angle

Integration of Eq. (3) gives for the flight path angle,

$$\begin{aligned} \varphi - \beta_0 = \frac{1}{mV - K_2} & \left\{ \left(\frac{K_1}{\lambda_1} + K_2 \right) C_1'' \cdot \lambda_1 t + \left(\frac{K_1}{\lambda_2} + K_2 \right) C_2'' \cdot \lambda_2 t \right. \\ & \left. - \left(\frac{K_1}{\lambda_1} + K_2 \right) C_1'' - \left(\frac{K_1}{\lambda_2} + K_2 \right) C_2'' \right\} \end{aligned}$$

DISPERSION

Bent fins or misalignment act as forcing terms in the equations of motion. As an illustration, for the lateral plane motion;

$$mV\dot{\beta} = K_1\alpha + K_2\delta + K_3\delta \sin \omega t$$

$$I\ddot{\beta} = C_1\alpha + C_2\delta + C_3\delta \sin \omega t$$

where δ is some acceptable statistic of the distribution of misalignment or bending, and ω is the frequency of rotation of the Hydroduct about its axis of symmetry.

SECRET

SECRET

This results in a sinusoidal forcing function in the differential equation for angle of yaw:

$$\ddot{\beta} + 2\zeta\omega_n \dot{\beta} + \omega_n^2 \beta = C_3 \delta \sin \omega t$$

and

$$\beta(t) = m_1 e^{\lambda_1 t} + m_2 e^{\lambda_2 t} + \left[\frac{C_3 \delta \sin(\omega t - \psi)}{\sqrt{(\omega_n^2 - \omega^2)^2 + 4\zeta^2 \omega_n^2 \omega^2}} \right]$$

The last term represents the steady state value of β , since all other terms die out exponentially. The coefficient in brackets in this steady state term should be small for the Hydroduct for reasonable values of ω , since the vehicle is well damped and ω_n is inherently large. Experiments on test versions appear to bear out the fundamentally low dispersion characteristics of the Hydroduct as far as symmetrical dispersions are concerned.

A rather large source of dispersion appears to be the result of random differences in thrust between Hydroducts during the test run. This would have the effect of essentially varying the equilibrium speed from one vehicle to the next, and would result mainly in dispersions in the vertical direction. Some secondary effect on symmetrical dispersions might be expected from variations in the values of ω_n and ζ in the steady state dispersion term which would result from variations in equilibrium speed.

m_1 and m_2 can be shown to consist of initial condition terms and terms containing δ which are independent of one another. Hence, the initial conditions in themselves would not be expected to contribute directly to dispersion. However, as pointed out above, if initial conditions result in deviations that might produce changes in the characteristic motion of the vehicle, dispersions from manufacturing tolerances or handling damage may be altered.

SECRET

APPENDIX III.

NUMERICAL VALUES

Values of the constants appearing in the equations given in Appendix II are estimated to be as follows:

$\frac{\partial C_L}{\partial \alpha}$	6.45 per rad
S441 ft ²
l_t	2.6 ft
W	215 lb (unburned) 115 lb (burned)
B	112.7 lb
Q	1.762 ft ³
k_1029
k_2945
l_b20 ft

At the launching speed of 250 feet per second (unburned),

$$A_1 = -K_1 = -178,000 \text{ lb}$$

$$A_2 = -K_2 = -1845 \text{ lb sec}$$

$$A_3 = 102 \text{ lb}$$

$$B_1 = C_1 = -259,000 \text{ lb ft}$$

$$B_2 = C_2 = -4,798 \text{ lb ft sec}$$

$$B_3 = -22.5 \text{ lb ft}$$

$$I = 17.6 \text{ slugs ft}^2 \text{ (including virtual inertia)}$$

$$m = 10 \text{ slugs (including virtual mass)}$$

With these values the damping ratio, ζ , is approximately 1.1 and the undamped natural frequency, ω_n , is approximately 25 cycles per second. The roots of the characteristic equation are $\lambda_1 = -93$ and $\lambda_2 = -249$. The steady state angle of attack, C_3 , is approximately .00047 radians. In the burned condition (15 seconds) at the speed of 250 feet per second,

$$W \approx 132 \text{ lb}$$

$$\omega_n = 30 \text{ cps}$$

$$m \approx 7.6 \text{ slugs}$$

$$\lambda_1 = -89$$

$$I \approx 12.9 \text{ slug ft}^2$$

$$\lambda_2 = -376$$

$$\zeta = 1.24$$

$$C_3 = .00056 \text{ radians}$$

At a speed of 150 feet per second ($d = 300 \text{ ft}$),

$$A_1 \approx -64,000 \text{ lb}$$

$$B_1 = -93,300 \text{ lb ft}$$

$$A_2 = -1,108 \text{ lb sec}$$

$$B_2 = -2,880 \text{ lb ft sec}$$

In the burned condition,

$$\zeta = 1.24$$

$$\lambda_1 = -57$$

$$\omega_n = 18 \text{ cps}$$

$$\lambda_2 = -223$$

$$C_3 = .00158 \text{ radians}$$

APPENDIX IV.

APPROXIMATE TRAJECTORY EQUATIONS

With the assumption of a very flat trajectory, the equations of motion in the vertical plane have been developed in References 4 and 5 into convenient expressions for the vertical trajectory of the form:

$$\ddot{y} = g^*(W)$$

$$\dot{z} = V \cos \gamma$$

where
$$g^*(W) = \frac{(1 - \rho')(1 - \delta') + \delta'}{(1 - \rho')(1 + k_1 \delta') + \delta'(k_2 - k_1)}$$

$$\delta' = \frac{B}{W}$$

$$\lambda = \frac{L_h}{L_t}$$

$$\varphi' = \frac{2Q(k_2 - k_1)}{S L_t \left(\frac{dCL}{d\alpha} \right)}$$

These items, and hence g^* , will vary with the weight as fuel is burned. With a burning rate of about 5.5 pounds per second, which corresponds to a total burning time of about 18 seconds, the expression for g^* becomes:

$$g^*(t) \approx .284 - .0098t - .000133t^2 = \frac{f}{g}$$

Integrating twice,

$$\gamma = V_0 \sin \gamma_0 - g \left(.142t^2 - .00163t^3 - .000011t^4 \right)$$

where γ_0 = angle of elevation of the flight path at the beginning of the trajectory

The value of V is a function of depth and also of any deceleration which takes place after launching. Hence, a stepwise integration is required in establishing the trajectory.

APPENDIX V.
DECELERATION

The approximate force equation along the direction of the x-axis of Fig. 1 is

$$m\dot{V} \approx T - D$$

The variation of thrust and drag with speed for the Hydroduct is illustrated in Fig. 3 on page 13. This figure indicates that thrust varies approximately as the speed, and drag varies approximately as the square of the speed at any given depth. Drag due to angle of attack and other higher order effects are negligible for all practical purposes. Hence, the above expression can be approximated in the form:

$$m\dot{V} \approx L_1 V + L_2 V^2$$

where $L_1 = \frac{T}{V}$ and $L_2 = -\frac{D_0}{V^2}$

These are constant at any fixed depth. When integrated, this expression gives, at any depth,

$$V = \frac{L_1 V_0 e^{(L_1 t/m)}}{L_1 + L_2 V_0 (1 - e^{(L_1 t/m)})}$$

V = final speed

V_0 = initial speed

At 300 feet depth, $L_1 \approx 5.0$ and $L_2 \approx -.033$. Using these values, approximately eight seconds are required to decelerate from an initial relative speed at launching of 270 feet per second to the equilibrium speed for that depth of 158 feet per second. Deceleration to 250 feet per second at 40 feet depth requires about four seconds. These same values hold also for the case of the lateral trajectory.

With the assumptions that (1) the rear of the vehicle is supported to move along the axis of the launcher, (2) the y-coordinate of the point of support does not change (rigid launcher), and (3) no support is provided by the lip of the launcher once the maximum diameter of the Hydroduct passes it, the condition of constraint becomes:

$$y \approx -l_t \theta_1$$

With these conditions and assumptions, the equations can be combined to give:

$$\left[1 + ml_t^2\right] \ddot{\theta}_1 + \left[A_2 l_t - B_2\right] \dot{\theta}_1 = (-W + B)l_t \cos \gamma_0 + M_f \alpha - B l_t \quad \dots (3)$$

Assuming that the increment in angle of attack developed at the center of gravity during launching is small, $\alpha \approx \alpha_0$, which is a known effect of cross stream conditions at the launcher.

The solution of this equation is:

$$\begin{aligned} \theta_1(t) &= \frac{\left[(-W + B)l_t \cos \gamma_0 + M_f \alpha_0 - B l_t\right] \left[1 + ml_t^2\right]}{\left[A_2 l_t - B_2\right]^2} \left[e^{-\frac{A_2 l_t - B_2}{1 + ml_t^2} t} + \frac{A_2 l_t - B_2}{1 + ml_t^2} t^{-1} \right] \\ &\approx \frac{Z_2}{Z_1^2} \left[e^{-Z_1 t} + Z_1 t - 1 \right] \end{aligned}$$

and
$$\dot{\theta}_1 \approx \frac{Z_2}{Z_1} \left[1 - e^{-Z_1 t} \right]$$

For the Hydroduct in launching condition at a speed of 250 feet per second,

$$\theta_1 \approx -.000217 \cos \gamma_0 - .000017 + .1505 \alpha_0 \quad \dots \dots \dots (4)$$

$$\dot{\theta}_1 \approx -.0339 \cos \gamma_0 - .00259 + 23.3 \alpha_0 \quad \dots \dots \dots (5)$$

The first two terms in these equations are the effects of gravity tip-off alone. The last term is the hydrodynamic tip-off effect. For the conditions assumed

here, the hydrodynamic tip-off effect will predominate at angles of attack above about 1° , and can become quite large at high launcher elevation and launching-submarine speed.

In the lateral trajectory case, all of the gravity and buoyancy terms drop out, and only the hydrodynamic term remains. Thus, the tip-off effect on launching off the bow of a moving submarine will be more extreme than that occurring in the vertical plane.

The equations of motion for tip-off shown above are written with the assumption that hydrodynamic forces and moments are fully effective. This is probably quite conservative, since blanketing effects of the launcher tend to have the effect of reducing the contribution of elements inside the launcher. Actually, the forces and moments are probably time-dependent as the vehicle leaves the launcher. Since there is no way to assess these effects at this time, they are not included in this analysis.

Also, the conditions of constraint may be altered by launcher design considerations, such as flexibility and clearances; however, again little is known about the launcher design at this time, and the conditions used in this analysis may not be representative of the final configuration.

The increment in angle of attack induced at the center of gravity by rotational velocities developed during tip-off is approximately $-\dot{\theta}L/V$. Neglecting this increment during tip-off introduces errors of the order of about 10% in θ and $\dot{\theta}$ which, in view of the other assumptions and approximations used, are for all practical purposes negligible. The actual increment in angle of attack should be included in the initial angle of attack for the transient period following tip-off.

A more exact solution could be obtained by a step-by-step integration of Eq. (3) over short time intervals during the tip-off.

Best Available Copy