

Armed Services Technical Information Agency

Because of our limited supply, you are requested to return this copy **WHEN IT HAS SERVED YOUR PURPOSE** so that it may be made available to other requesters. Your cooperation will be appreciated.

AD

32562

NOTICE: WHEN GOVERNMENT OR OTHER DRAWINGS, SPECIFICATIONS OR OTHER DATA ARE USED FOR ANY PURPOSE OTHER THAN IN CONNECTION WITH A DEFINITELY RELATED GOVERNMENT PROCUREMENT OPERATION, THE U. S. GOVERNMENT THEREBY INCURS NO RESPONSIBILITY, NOR ANY OBLIGATION WHATSOEVER; AND THE FACT THAT THE GOVERNMENT MAY HAVE FORMULATED, FURNISHED, OR IN ANY WAY SUPPLIED THE SAID DRAWINGS, SPECIFICATIONS, OR OTHER DATA IS NOT TO BE REGARDED BY IMPLICATION OR OTHERWISE AS IN ANY MANNER LICENSING THE HOLDER OR ANY OTHER PERSON OR CORPORATION, OR CONVEYING ANY RIGHTS OR PERMISSION TO MANUFACTURE, USE OR SELL ANY PATENTED INVENTION THAT MAY IN ANY WAY BE RELATED THERETO.

Reproduced by
DOCUMENT SERVICE CENTER
KNOTT BUILDING, DAYTON, 2, OHIO

UNCLASSIFIED

AD No. 32 562

ASTIA FILE COPY

~~RESTRICTED~~

BIMONTHLY PROGRESS REPORT
R-222.24-53, PIB-167.24

on

ATTENUATORS

April 1953 - May 1953

Prepared for

BUREAU OF SHIPS

Contract No. NObsr-43360

Index No. 100-402



POLYTECHNIC INSTITUTE OF BROOKLYN
MICROWAVE RESEARCH INSTITUTE

~~RESTRICTED~~

~~SECURITY INFORMATION~~

Microwave Research Institute
Polytechnic Institute of Brooklyn
55 Johnson Street
Brooklyn 1, New York

Report R-222.24-53, PIB-167.24
Contract No. Nobsr-43360
Index No. 100-402

BIMONTHLY PROGRESS REPORT

For the Months of

April 1953 - May 1953

on

Navy Contract NObsr-43360

"Attenuators"

Classification cancelled in accordance with
Executive Order 10464 issued 5 November 1953

J. Beil
6/21/54

Document Service Center
Armed Services Tech. Info Agency

Title Page
4 Pages of Text
27 Pages of Figures

Author:

Anthony B. Giordano

Anthony B. Giordano
Research Supervisor

Approved:

Ernst Weber

Ernst Weber
Director

Brooklyn 1, New York

June 17, 1953

RESTRICTED

~~RECEIVED~~

I. Scope of the Program

The present phase of the program is based upon the following objectives:

1. The development of a variable coaxial attenuator for 7/8" coaxial line with broadband characteristics.
2. The development of high-power broadband probe-type attenuators.
3. The design of fixed coaxial attenuators for 3/8" coaxial line.
4. The preliminary development of a magnetic attenuator.
5. The measurement of phase-shift characteristics of attenuators designed for the frequency range of 2600-10,000 mc/sec.

II. Detailed Data*

A. Variable 7/8" Coaxial Attenuator

The unit described in the last progress report has been built. It consists of an IRC card of very high resistivity, permanently shunted across the line and producing an initial insertion loss. By means of a metallic plate lowered from the outer conductor and capacitively coupled to the IRC card, the total admittance of the attenuator section is varied. The principle of operation and the dimensions of the principle elements are indicated in Fig. MRI-13259. In the present preliminary design, the resistivity of the IRC card is very large. The insertion loss varies between 1 and 5 db over the frequency range 1500 - 4600 Mc/s. as shown by Fig. MRI-13260. The latter result shows that the frequency dependence of the attenuator is intrinsic in the unit; presumably it is not due to skin effect variation of the resistivity, because the thickness of the conductive film of the card is very small.

The unit works according to the principle of design. The attenuation and VSWR graphs for the limit frequencies of the prescribed range are indicated in Fig. MRI-13261 and show a total variation of the attenuation of 20 db with a VSWR less than or equal to 1.3. In these experiments, the IRC card was electrically connected to the outer and inner conductors by means of silver paint; its resistive film was protected with cellophane. Attenuation measurements have also been taken with the film unprotected; they show no fundamentally different result especially at the high frequencies as illustrated by Fig. MRI-13262. In general, the measurements were disturbed by the presence of radiation losses which could not be eliminated without certain important modifications of the design. Such modifications will be undertaken now and it is hoped that when this is done and the IRC card is replaced with one of more appropriate resistivity the total attenuation will be approximately doubled.

* Contributors to this report include Messrs Ammiratti, Kantrowitz, Rapaport, Wind, Bollinger and Dr. Vallese

~~RECEIVED~~

It is interesting to notice that the frequency dependence of the db curves is practically equal to that observed in the attenuator unit previously investigated. It is observed by Fig. MRI-13263 that at constant insertion the attenuation varies approximately linearly with frequency and, at maximum insertion, with a rate of 5.8 db per 1000 Mc/s. However the present design of the attenuator appears as an improvement with respect to the older one from the engineering point of view, since in it any motion of the delicate IRC oard or glass plate is eliminated.

B. Probe Attenuators

Word has not been received from the New York Naval Shipyard regarding the availability of facilities to test developed probe attenuator units at high (rf) powers.

1. 1 5/8" Coaxial Probe Attenuator

Measurements have been completed and an optimum design has been specified for the probe tip. These tests show that for a probe diameter of 0.201" a probe depth of 0.161" is optimum. Fig. MRI-13224 shows the variation in probe decoupling for the various probe tips tested. The variation of input voltage standing wave pattern for the 0.161" probe tip is shown in Fig. MRI-13223.

A final design has been made up using a combination jacket and probe tip in Teflon.

2. L-band Probe Attenuator

A quick check of the decoupling attainable with the L-band unit indicated a decoupling level of approximately 30 db. The r-f substitution method discussed in Report R-222.23-53 was abandoned due to difficulty in obtaining sufficient power from the oscillators available in L-band.

Since a level of approximately 60 db was desired, tests were attempted with a new power oscillator capable of supplying 10 to 20 watts average power in L-band. Unfortunately, because of the difficulty in getting the high power oscillator to function properly there was a delay in the measurement program.

C. Fixed Attenuators for 3/8" Coaxial Line

As explained in Report R-222.23-53 an alternative measurement system for the tenth decibel series film attenuators was instituted. This was based on the measurement of the absolute power delivered to a bolometer element which serves as one arm of a wheatstone bridge. Preliminary tests indicated that in addition to the factor of stability of both the d-o and r-f power sources there must be added the factor of temperature sensitivity of the bolometer element.

Attempts are being made to minimize these factors.

Further modification of the 0.8 db and 8.0 db chimney-type attenuators has resulted in the extension of the working range of these units up to 4000 Mc/sec. The results are listed in Table I and comparison plots are shown by Figs. MRI-13322 and MRI-13323. It is anticipated that the remainder of the chimney-type attenuators will be assembled and tested for the next report.

TABLE I

Characteristics of 0.8db and 8.0db Nominal
Re-Modified Chimney-Type Attenuators

VSWR

Frequency in Megacycles per Second

No. db	1000	1500	2000	2500	3000	3500	4000
0.8	1.03	1.1	1.15	1.15	1.15	1.15	1.25
8.0	1.05	1.1	1.18	1.15	1.11	1.15	1.17

ATTENUATION

Frequency in Megacycles per Second

No. db	1000	1500	2000	2500	3000	3000	4000
0.8	0.8	0.8	0.8	0.8	0.9	1.0	1.1
8.0	8.0	8.0	8.2	8.2	8.4	8.6	8.8

D. Magnetic Attenuator

Further measurements of the attenuation characteristics of polyiron D, Ferramics C and G, and Lavite F-4, have been made. As indicated in the last bimonthly progress report R-22.53, PIB-167.23, the major emphasis has been the compilation of further data for an extended frequency region. The appended curves, Figs. MRI-13225 and through MRI-13242, are constructed similarly to those of the last report so that comparisons may be made of the attenuation of similar specimens at 2000 and 3000 mc. In addition, curves of Figs. MRI-13240 through MRI-13242 show VSWR as a function of magnetizing current for polyiron D and Lavite F-4.

Comparison of the 2000 and 3000 mc/sec. curves indicates that the variation in power level as a function of magnetizing current increase with frequency.

It has been observed that the ferrites being used are temperature sensitive. Consequently, the data obtained may be subject to some error. However, precautions are being taken to eliminate this error source.

Program for the next period will be to extend measurements into the 3000 mc/sec. - 4000 mc/sec. region.

E. Phase-Shift Measurements

A standard phase-shifter has been designed, constructed, and tested for guide size 1-1/2" x 3/4". As evidenced by data presented in the last progress report, it was necessary to increase the taper lengths of the glass dielectric plate to four inches.

The overall bridge system is being assembled to measure the phase-shift characteristics of attenuator 1-1/2" x 3/4". Final data will be shortly available.

III. Program for the Next Period

1. Improvement of frequency sensitivity of 7/8" variable coaxial attenuator.
2. Final check of 1-5/8" probe attenuator with Teflon jacket.
3. Testing of the L-band probe attenuator to realize 60 db decoupling.
4. Testing of newly designed series film and chimney-type fixed attenuators.
5. Measurements of attenuation characteristics of polyiron and ferrite samples over the frequency range of 3000-4000 mc/sec.
6. Completion of phase-shift measurements of 1-1/2" x 3/4" waveguide attenuator.

SKETCH OF NEW ATTENUATOR UNIT

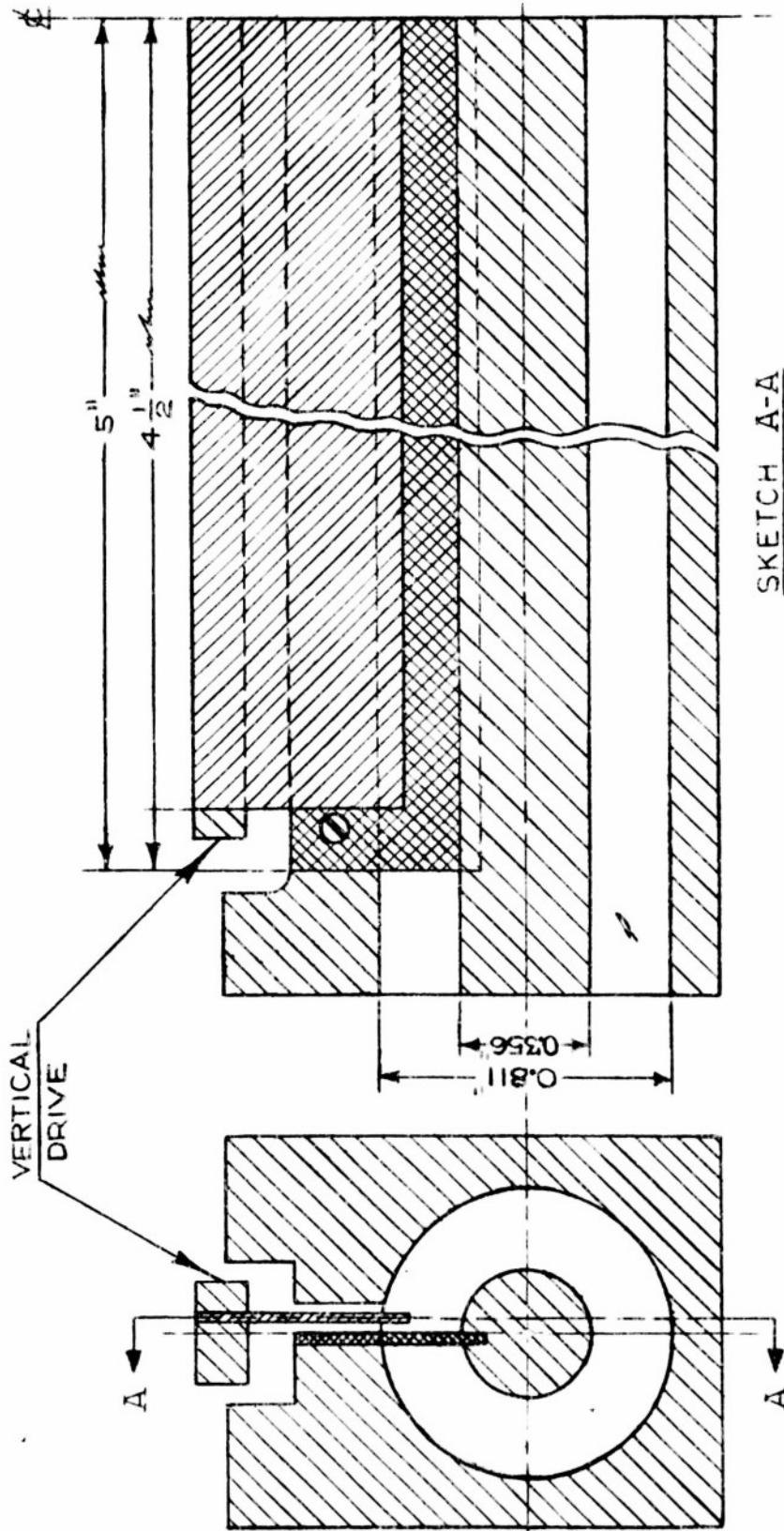

INSERTION LOSS OF NEW ATTENUATOR UNIT

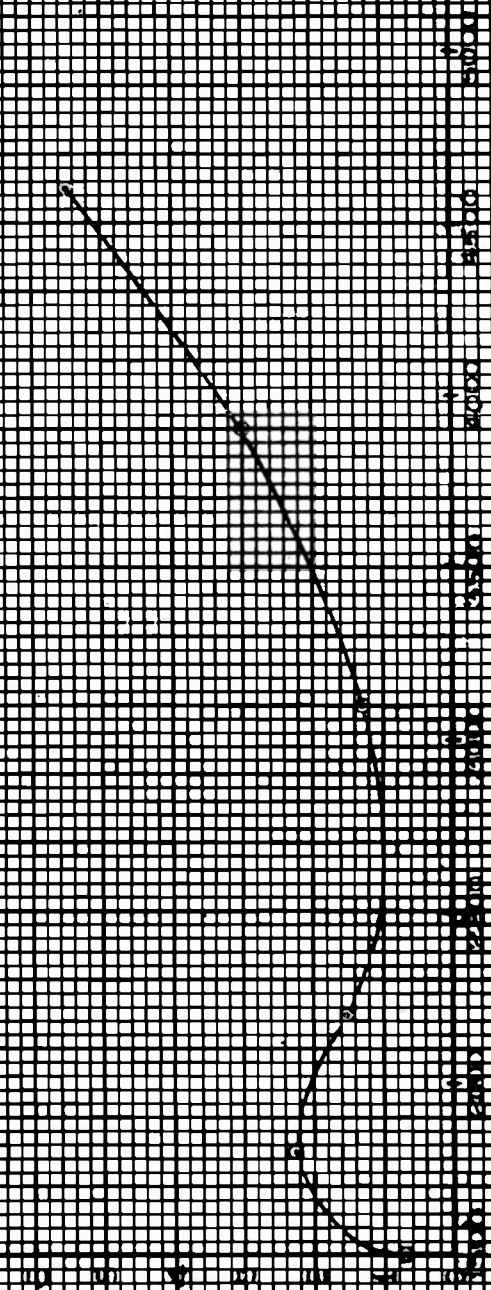

RESEARCH LABORATORY (MAY 1957)

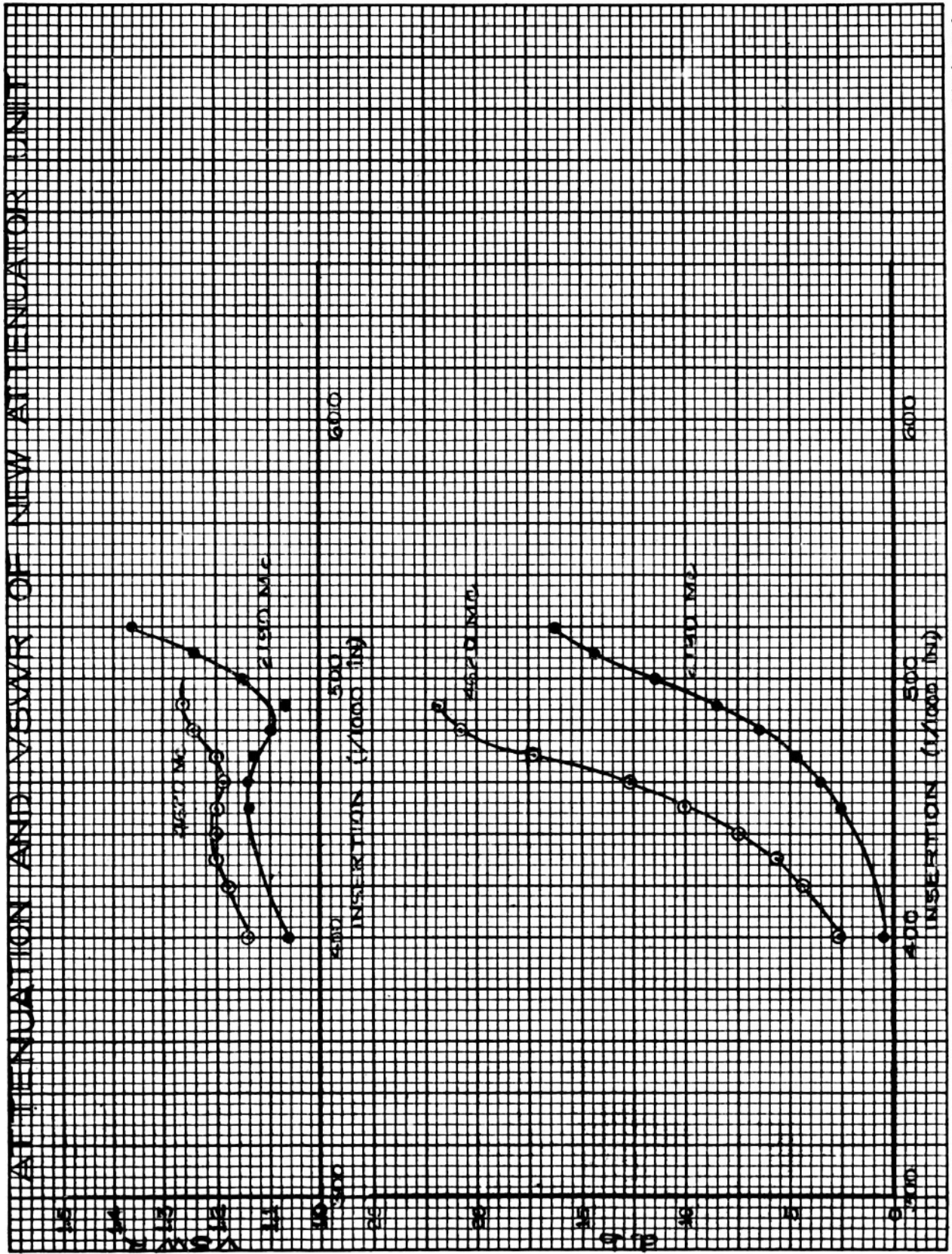

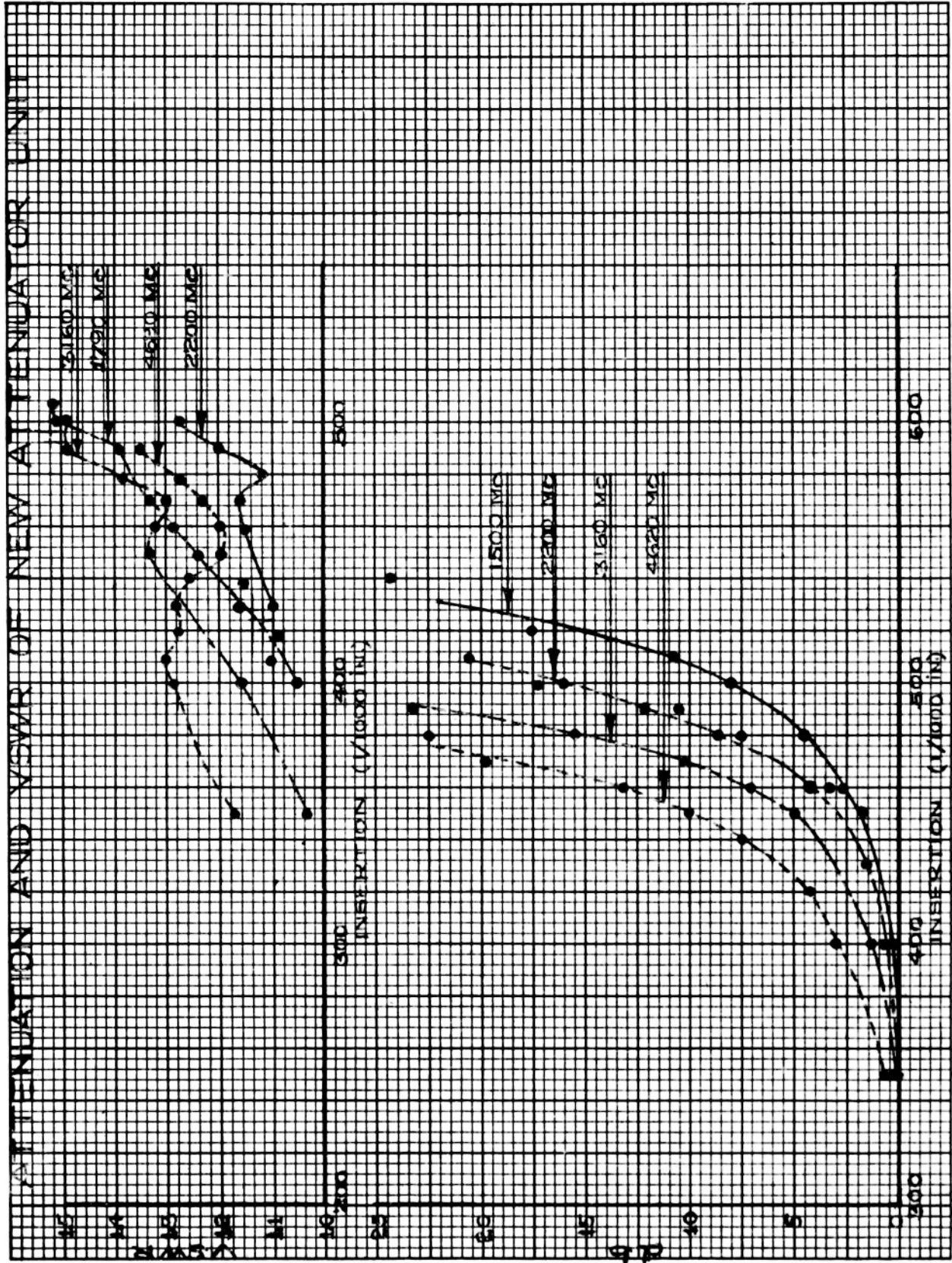

ATTENUATION VERSUS FREQUENCY FOR VARIOUS INJECTION VOLUMES

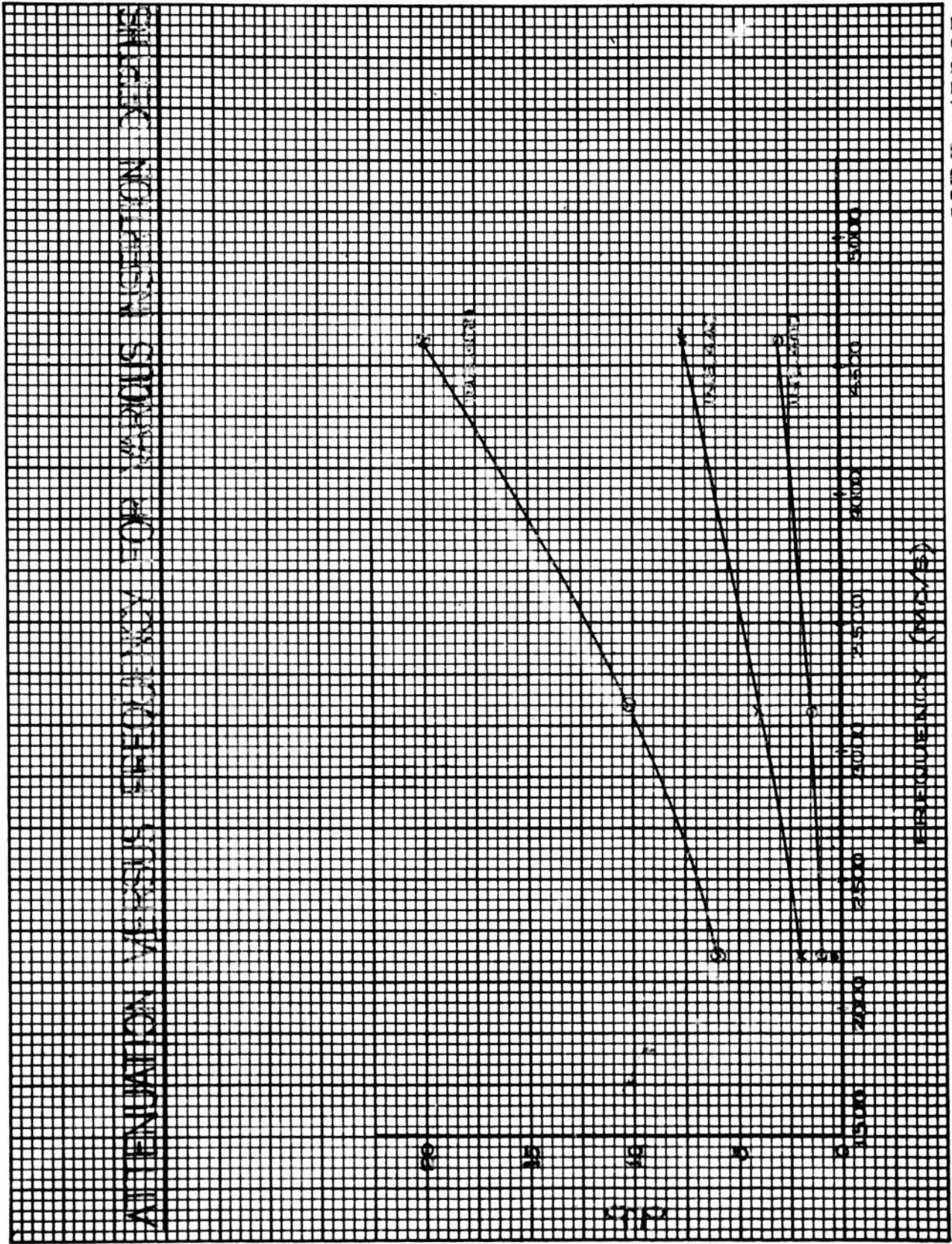

$1\frac{5}{8}$ " PROBE DEPTH DIMENSION

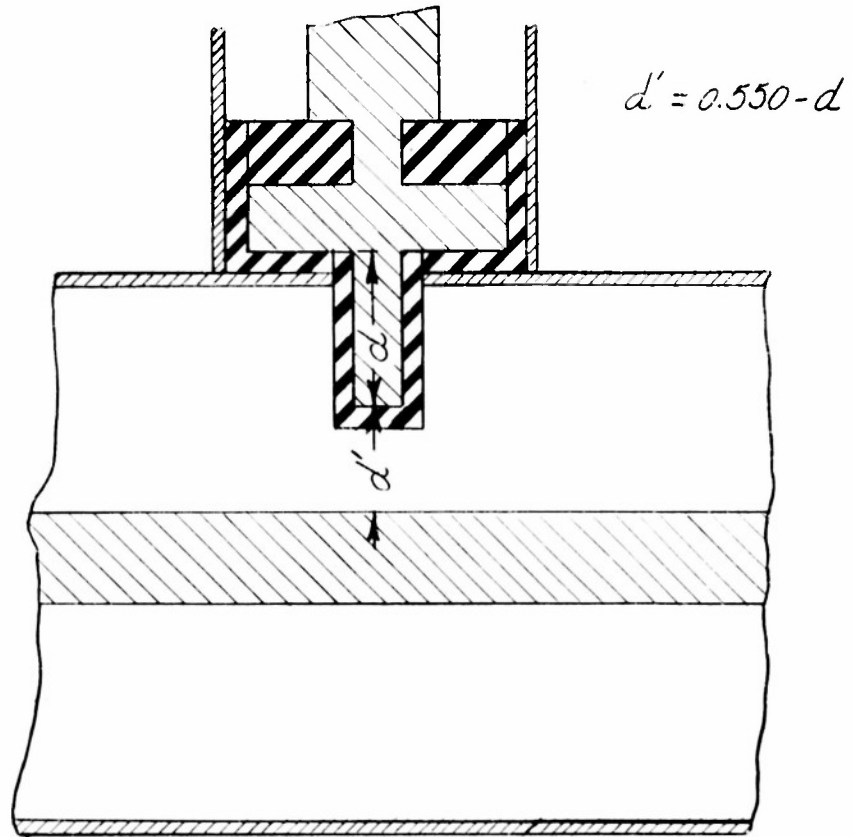

MEASURED V.S.W.R.
 $1\frac{5}{8}$ " COAXIAL PROBE ATTENUATOR $d = 0.161$ "
PROBE DIAMETER 0.201 "

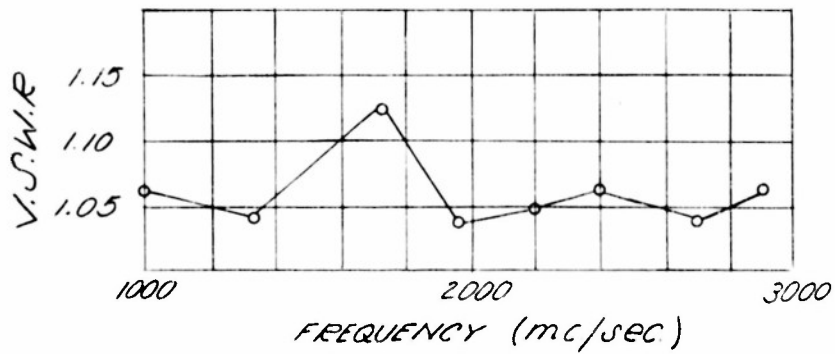

MEASURED ATTENUATION CHARACTERISTICS

1/8" MAXIAL LINE PROBE — PROBE DIA. 0.200"
 (USING CROSS SECTION SECTIVE)

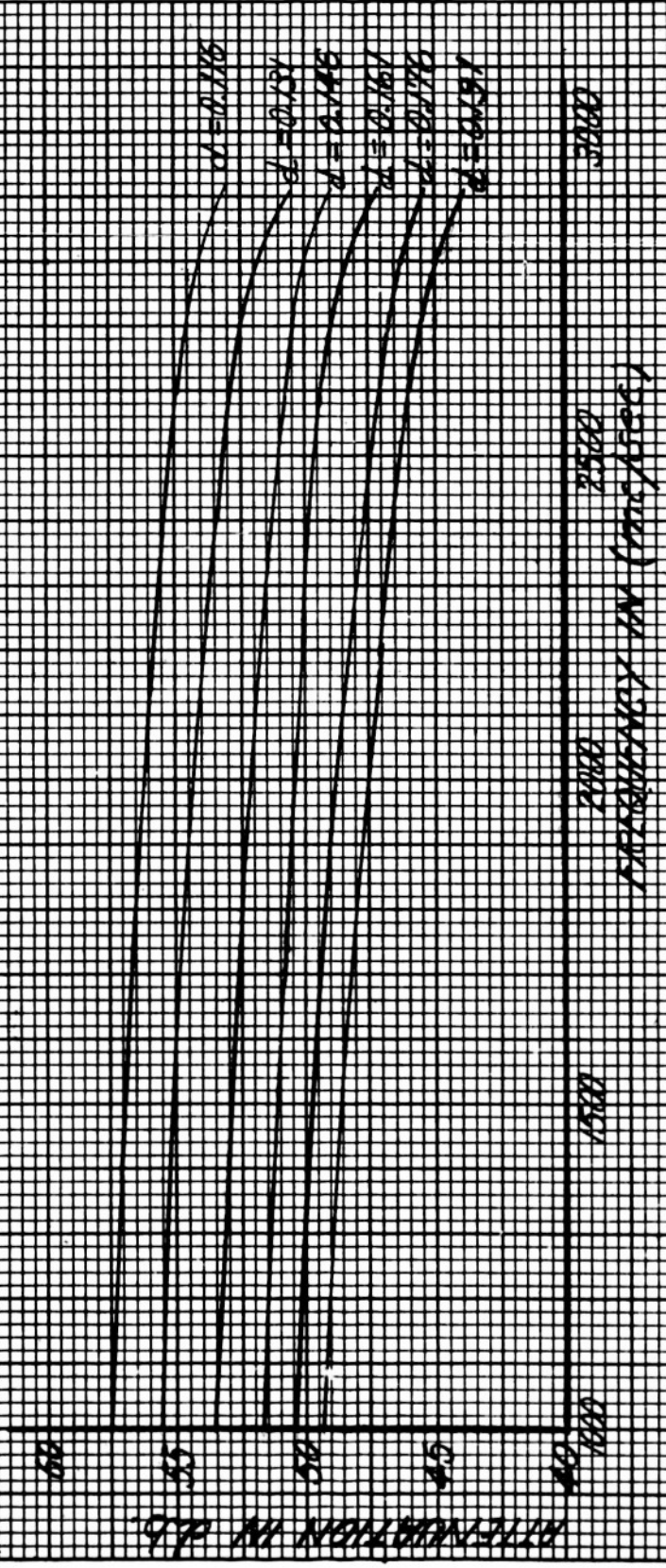

MAR 1952

6-53

VSWR & ATTENUATION CHARACTERISTICS
 1000 - 4000 MC/S
 0.8 db NOMINAL REMODIFIED CHIMNEY-TYPE ATTENUATOR

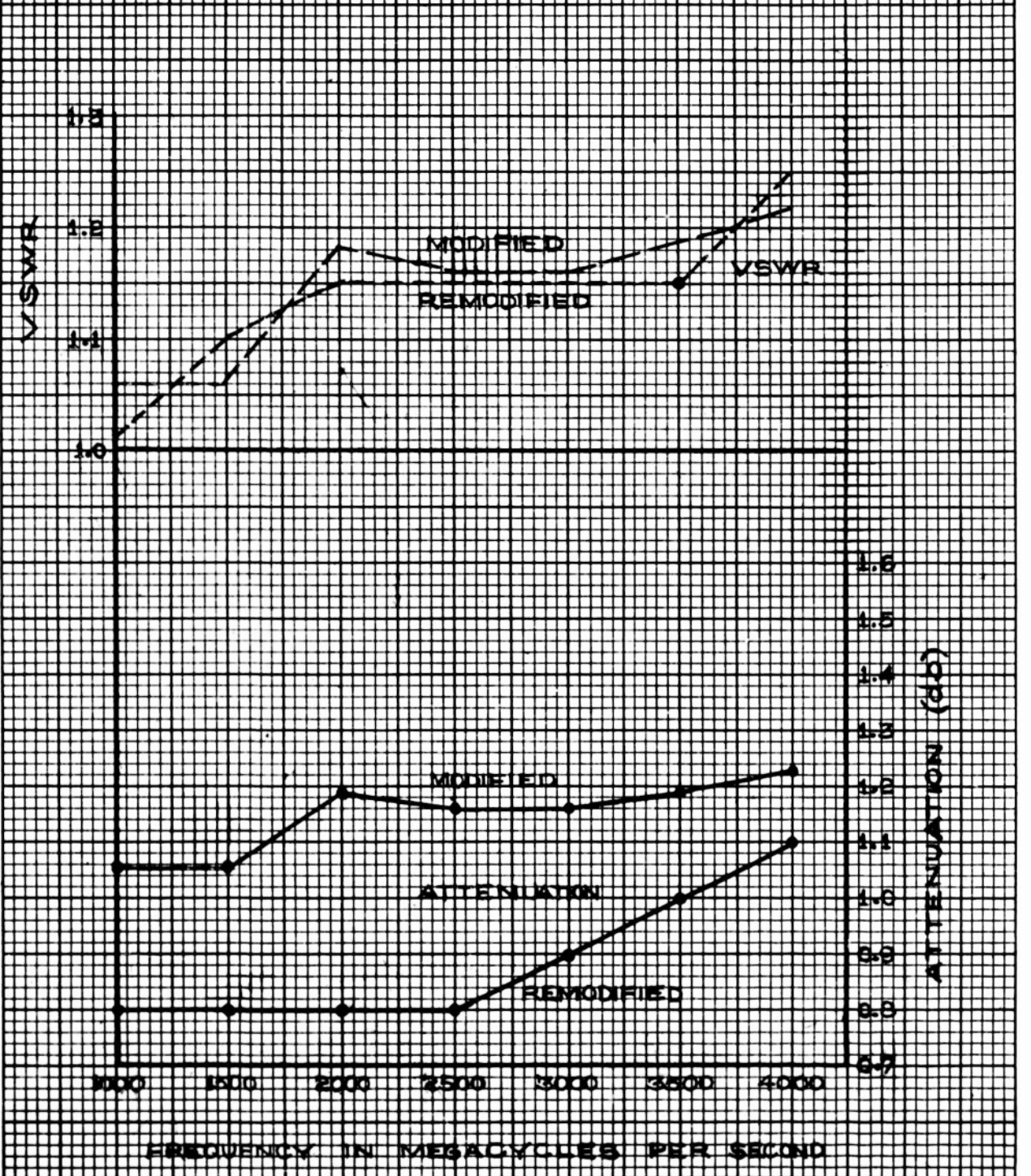

VSWR & ATTENUATION CHARACTERISTICS
 1000-4000 MC/S
 8.0 db NOMINAL-REMODIFIED CHIMNEY-TYPE ATTENUATOR

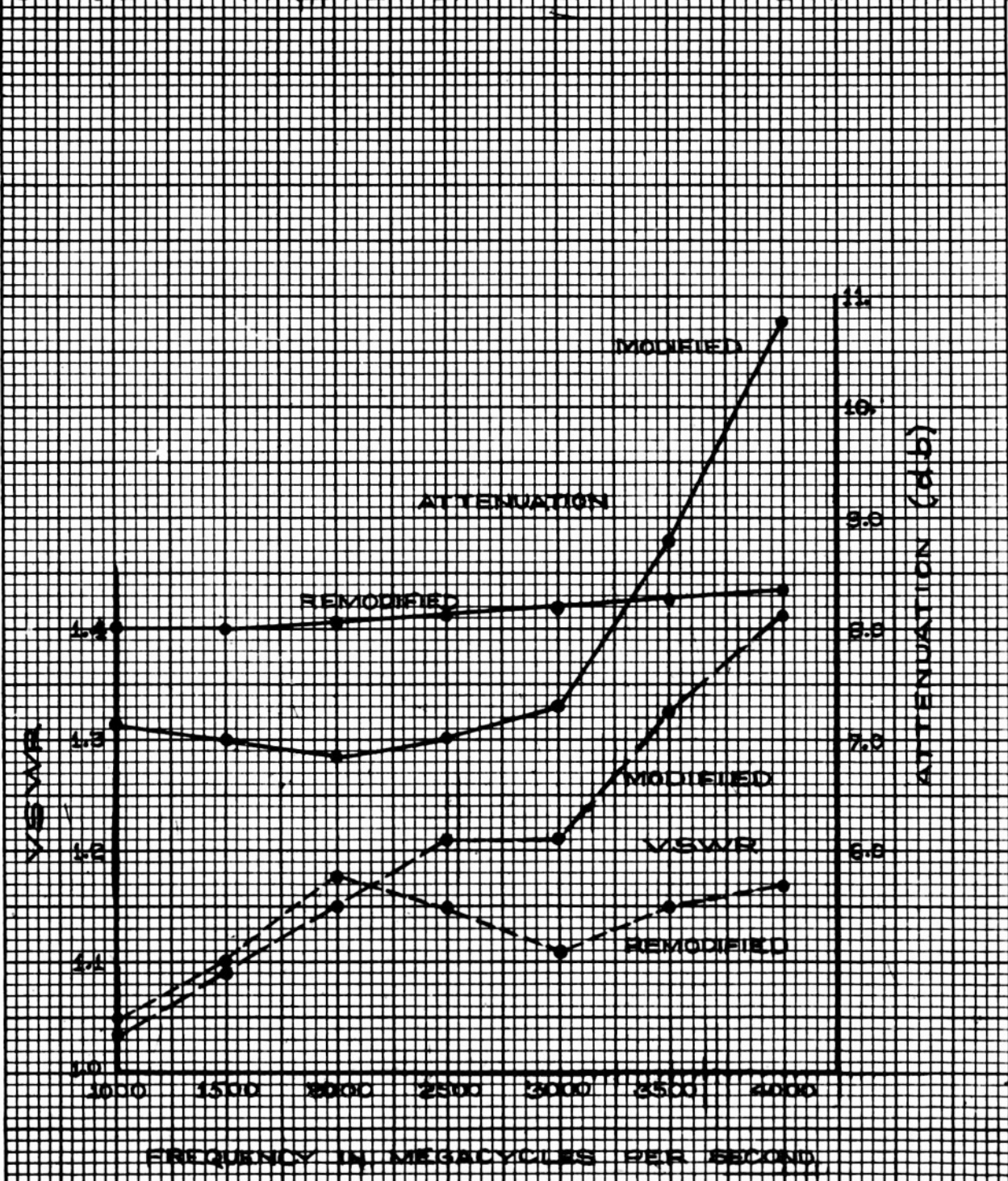

CALIBRATION CURVE FOR MAGNETIZING COIL

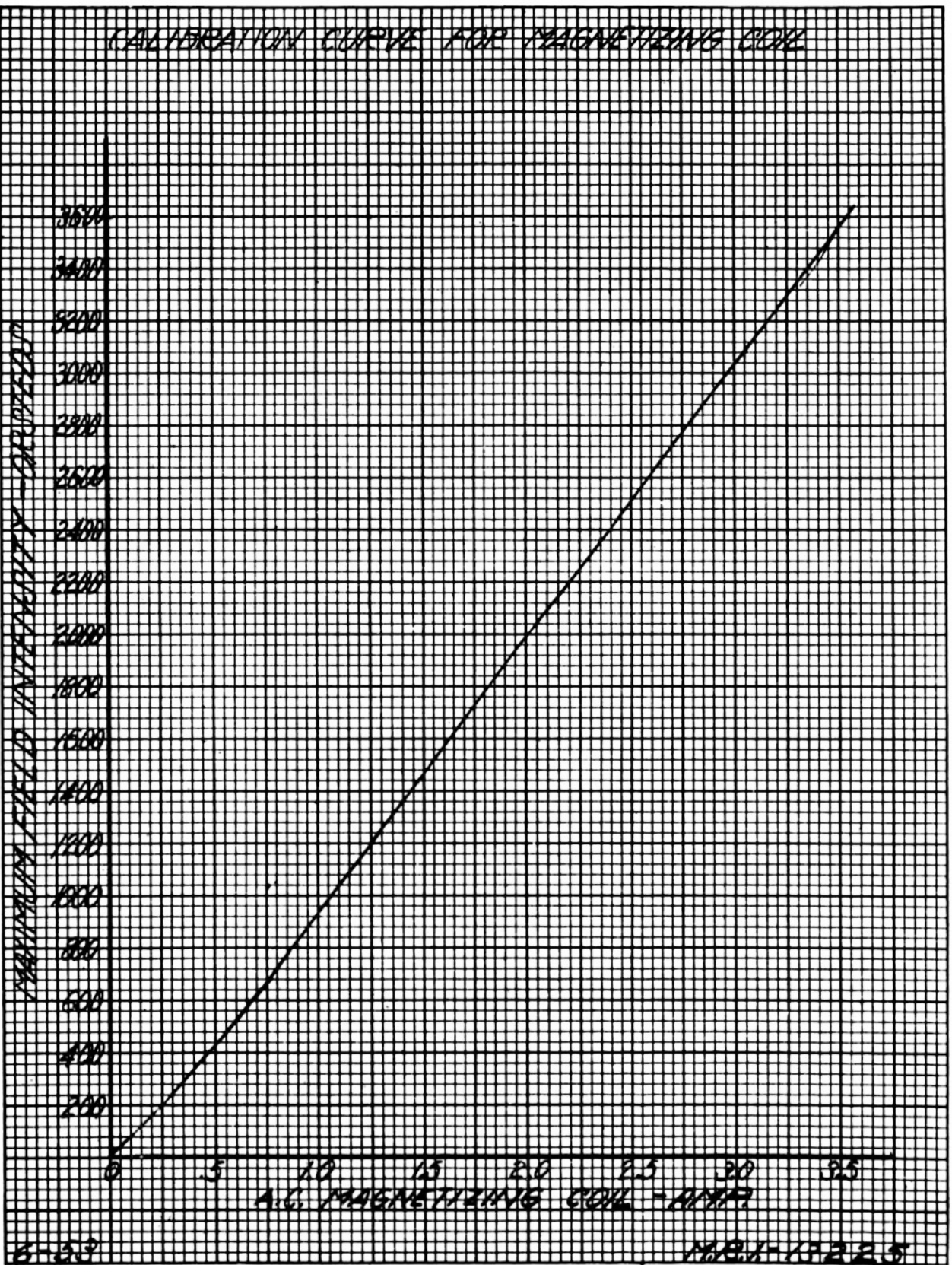

6-33

M.B.I-13225

VARIATIONS IN POWER LEVEL AS A FUNCTION OF A.C. MAGNETIZING CURRENT FOR BUTTED POLYTRON D AT 3000 MC.

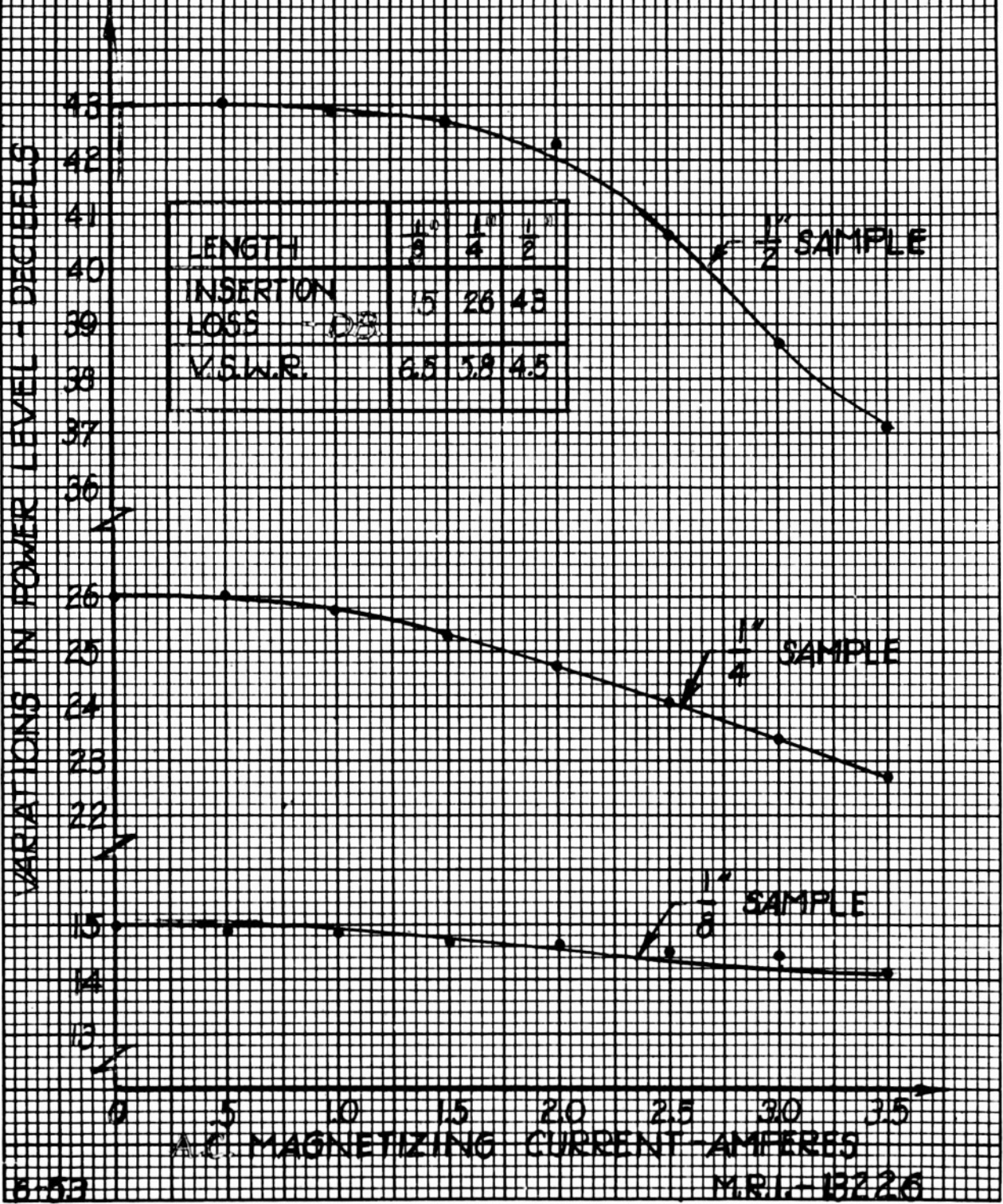

VARIATIONS IN POWER LEVEL AS A FUNCTION OF D.C. MAGNETIZING CURRENT FOR BUTTED POLYIRON D AT 3000 MC.

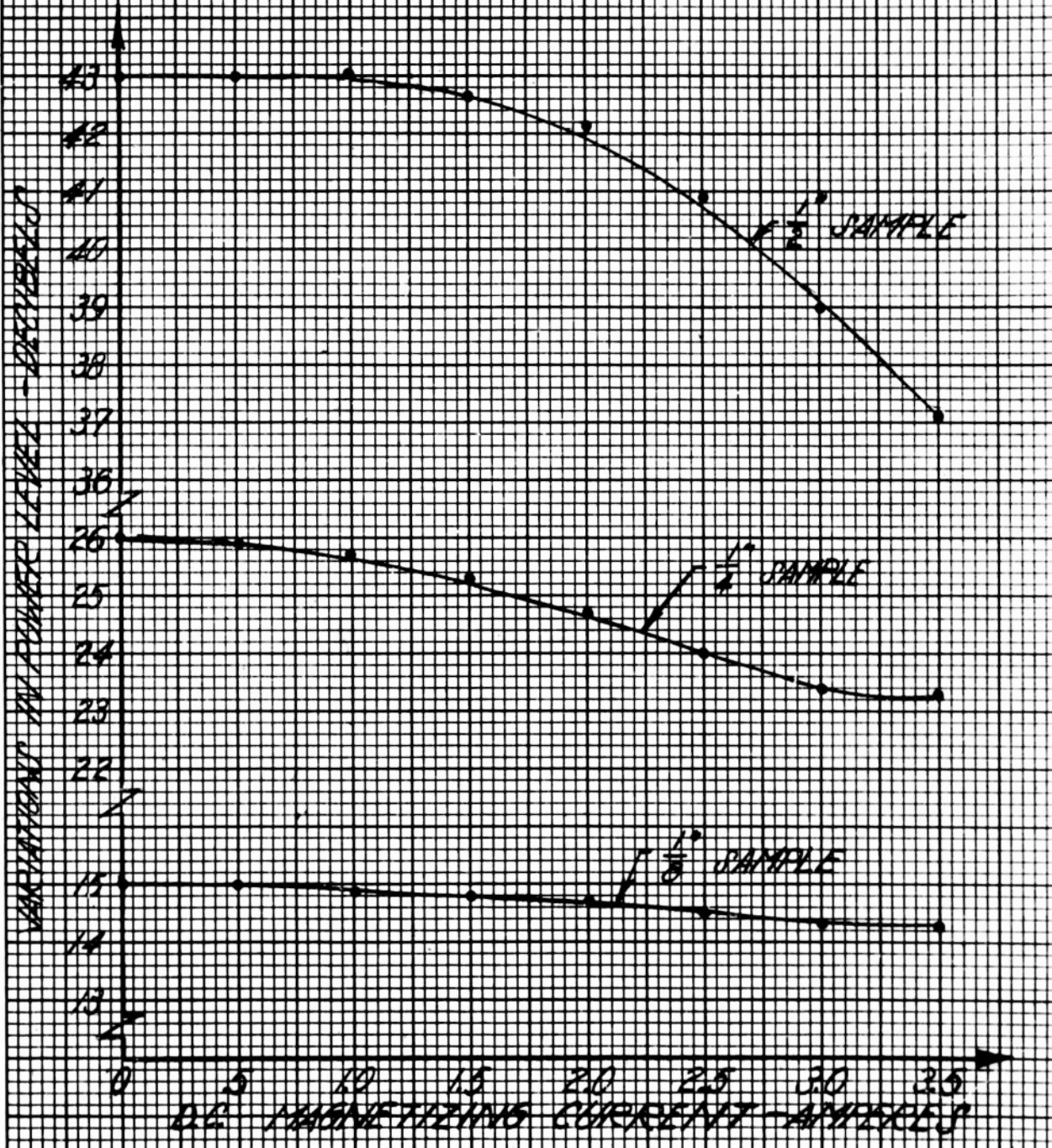

VARIATIONS IN POWER LEVEL AS A FUNCTION OF A.C. MAGNETIZING CURRENT FOR BUTTED FERRAMIC AT 3000 MC.

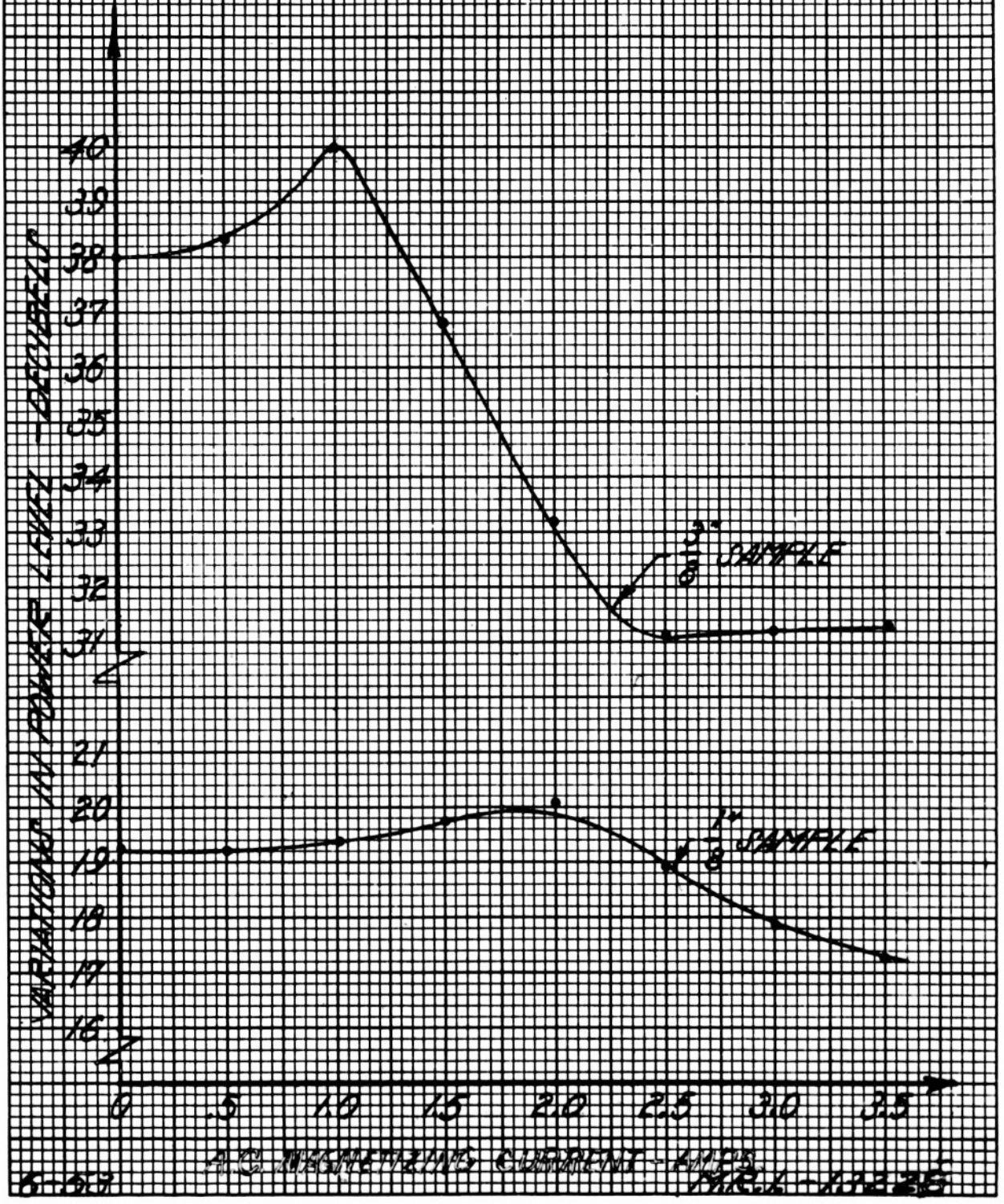

6-67

A.C. MAGNETIZING CURRENT - AMPS
M.E.L. - 11225

VARIATIONS IN POWER LEVEL AS A
 FUNCTION OF AC MAGNETIZING CURRENT
 FOR BILTED FERRIMAG AT 3000 MC

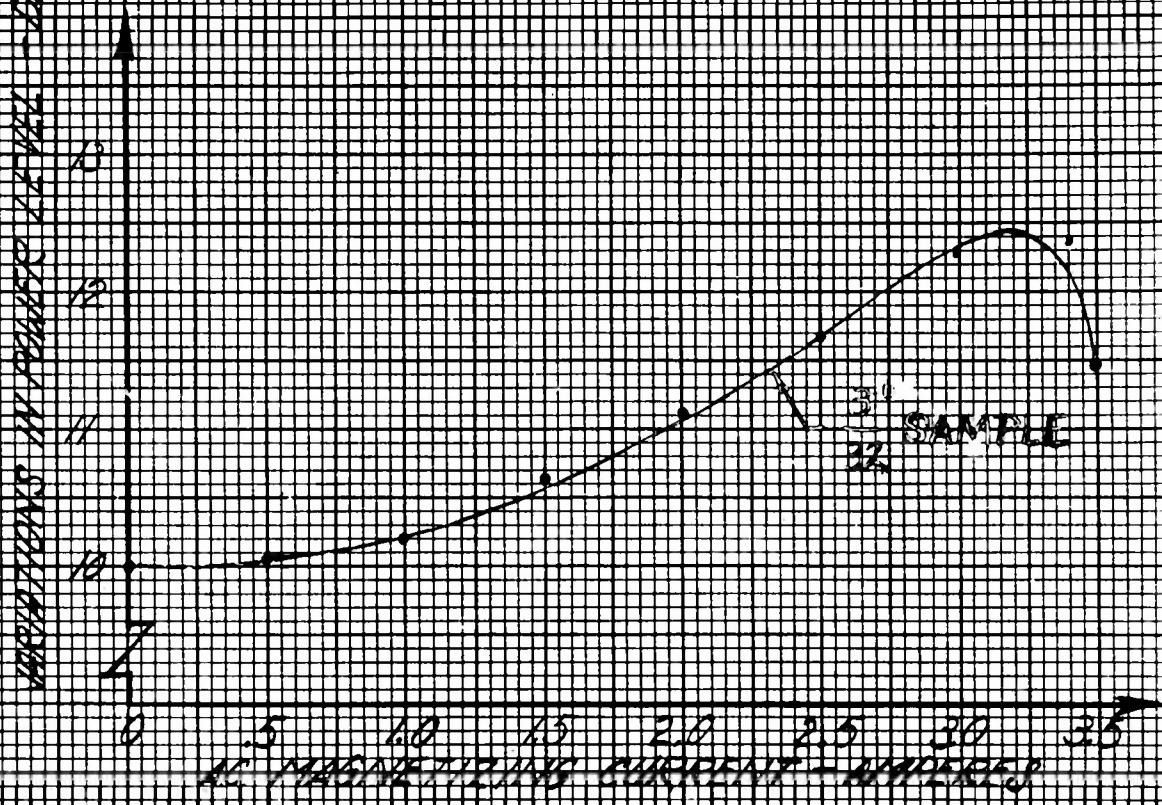

LENGTH	34	14	5
	32	8	8
INSERTION LOSS - DB	10	19.2	38
POWER	70	70	70

VARIATIONS IN POWER LEVEL AS A FUNCTION
 OF DC MAGNETIZING CURRENT FOR BITTED
 FERRANIC "C" AT 3000 MAC

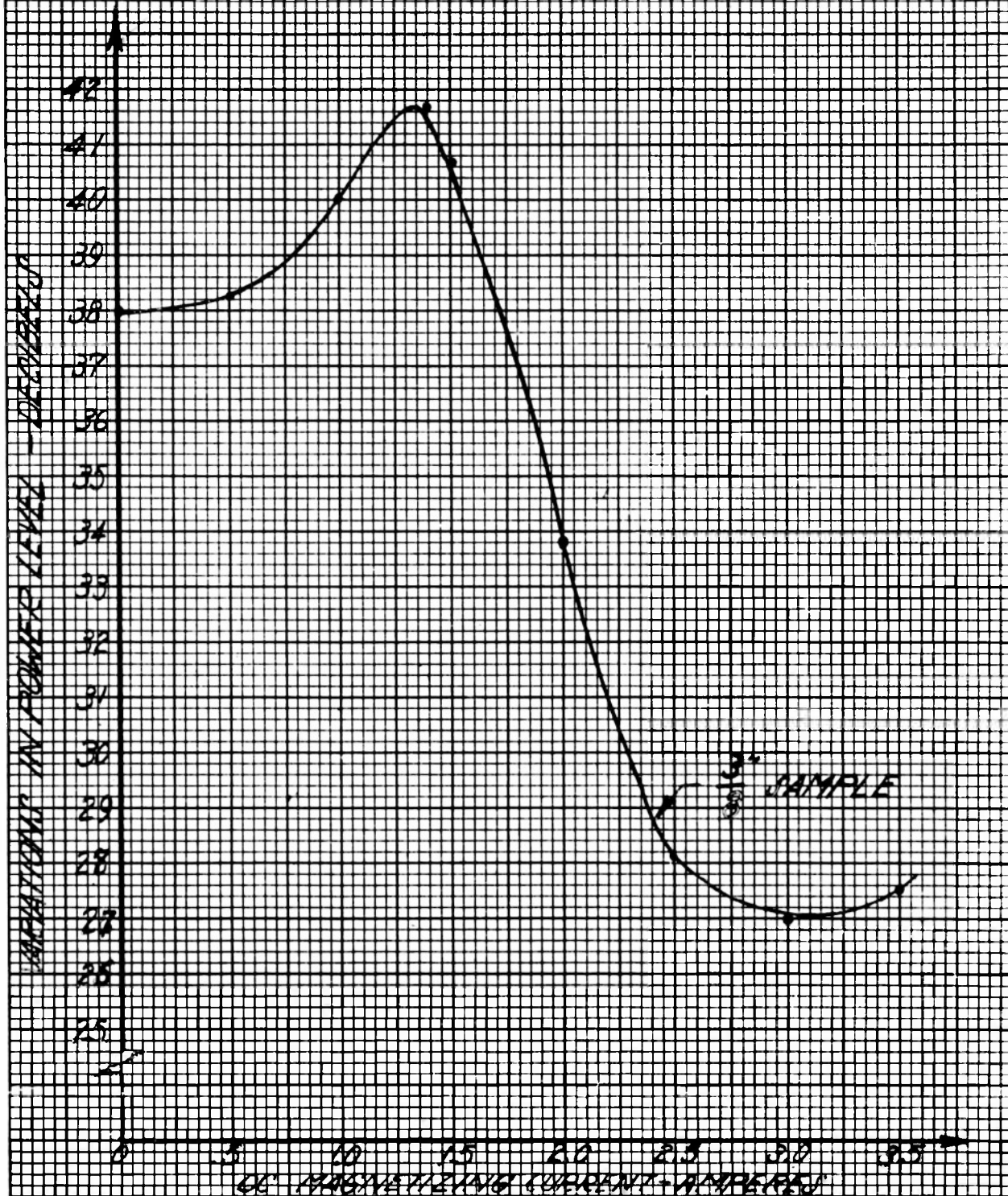

VARIATIONS IN POWER LEVEL AS A FUNCTION OF D.C. MAGNETIZING CURRENT FOR BUTTED FERRANIC "C" AT 3000 MC.

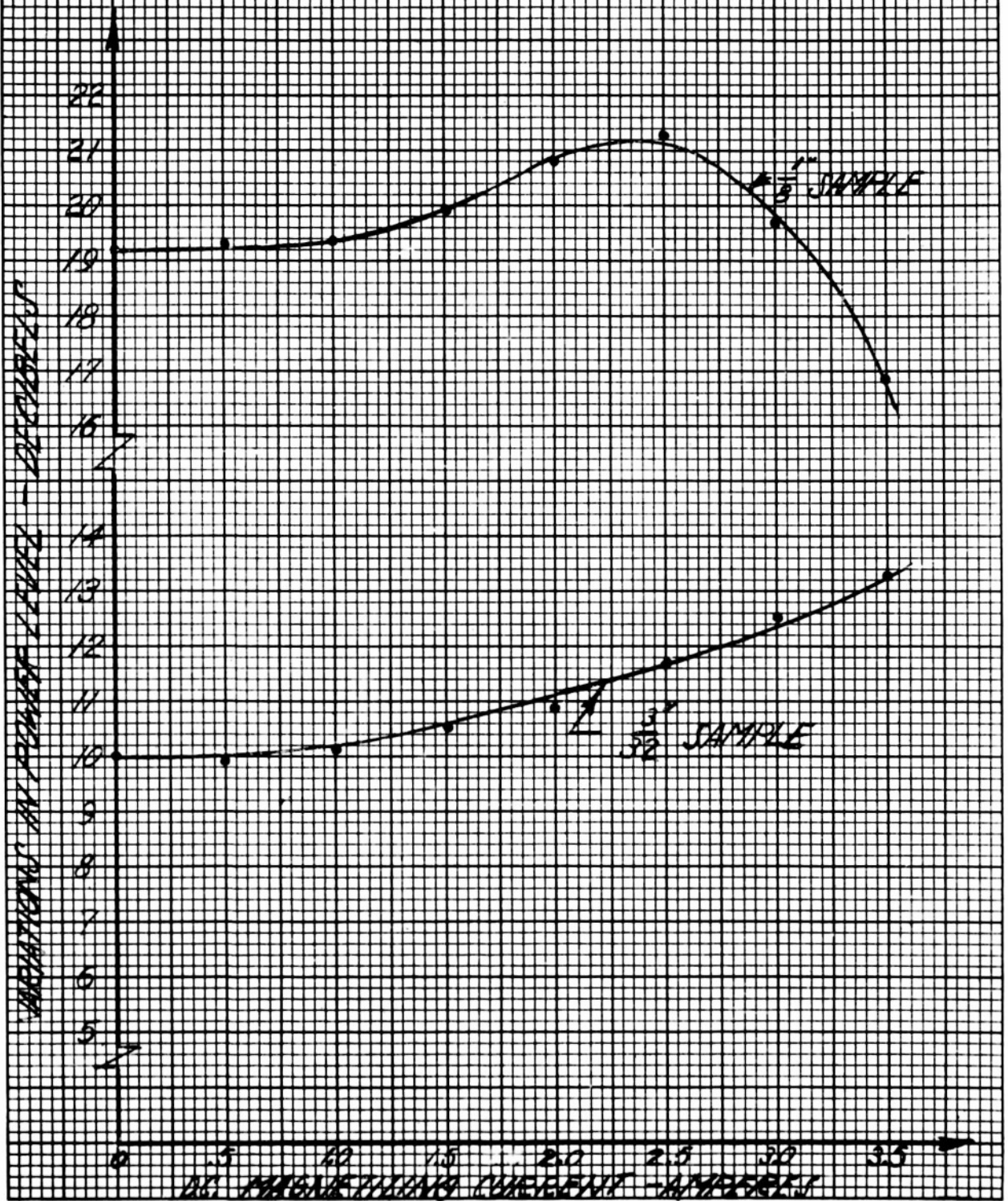

VARIATIONS IN POWER LEVEL AS A FUNCTION OF AC MAGNETIZING CURRENT FOR MIXED FERRITE 6 AT 300 MC.

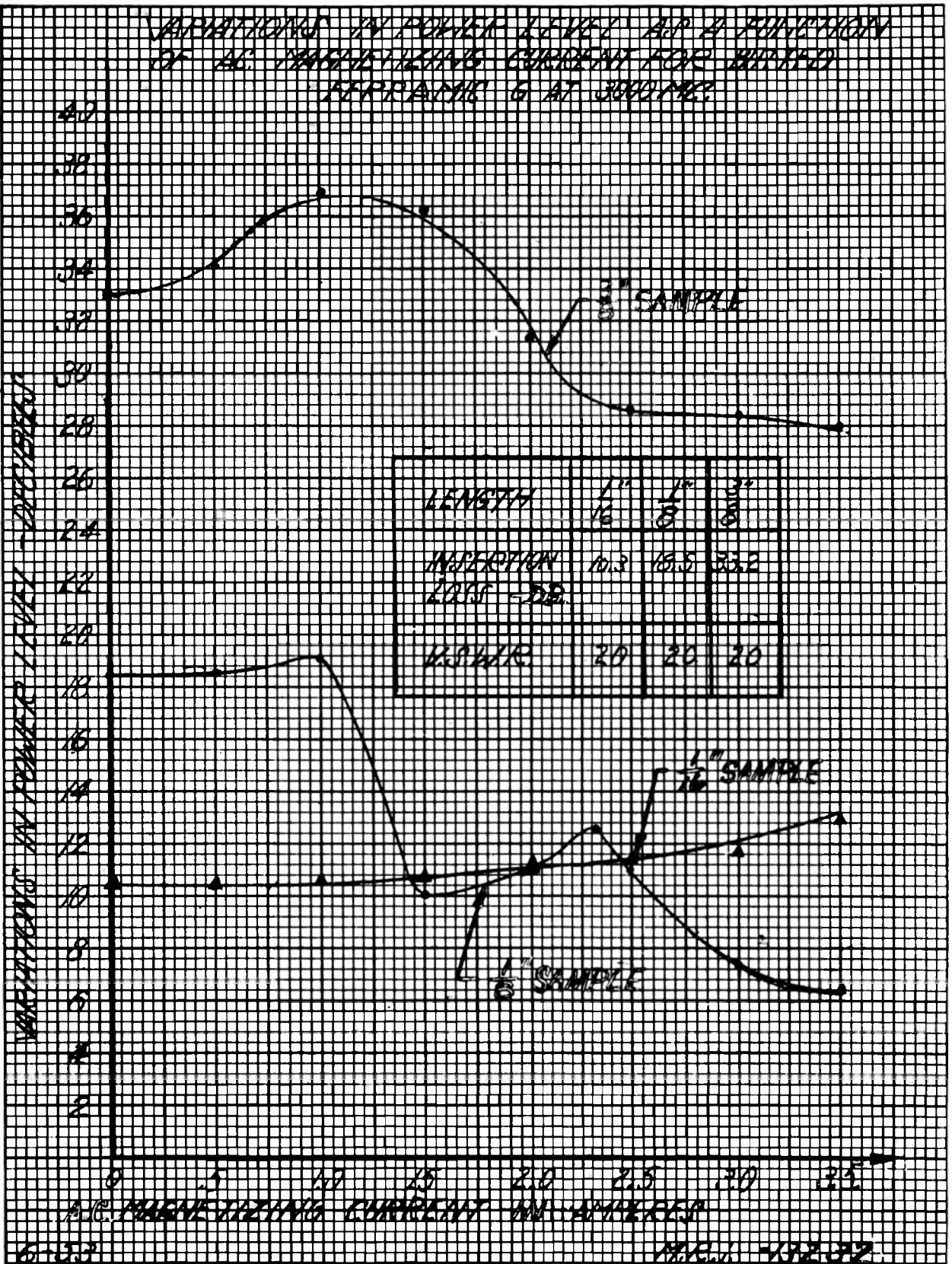

VARIATIONS IN POWER LEVEL AS A FUNCTION OF D.C. MAGNETIZING CURRENT FOR BILTIED FERRANITE @ 1000 MC

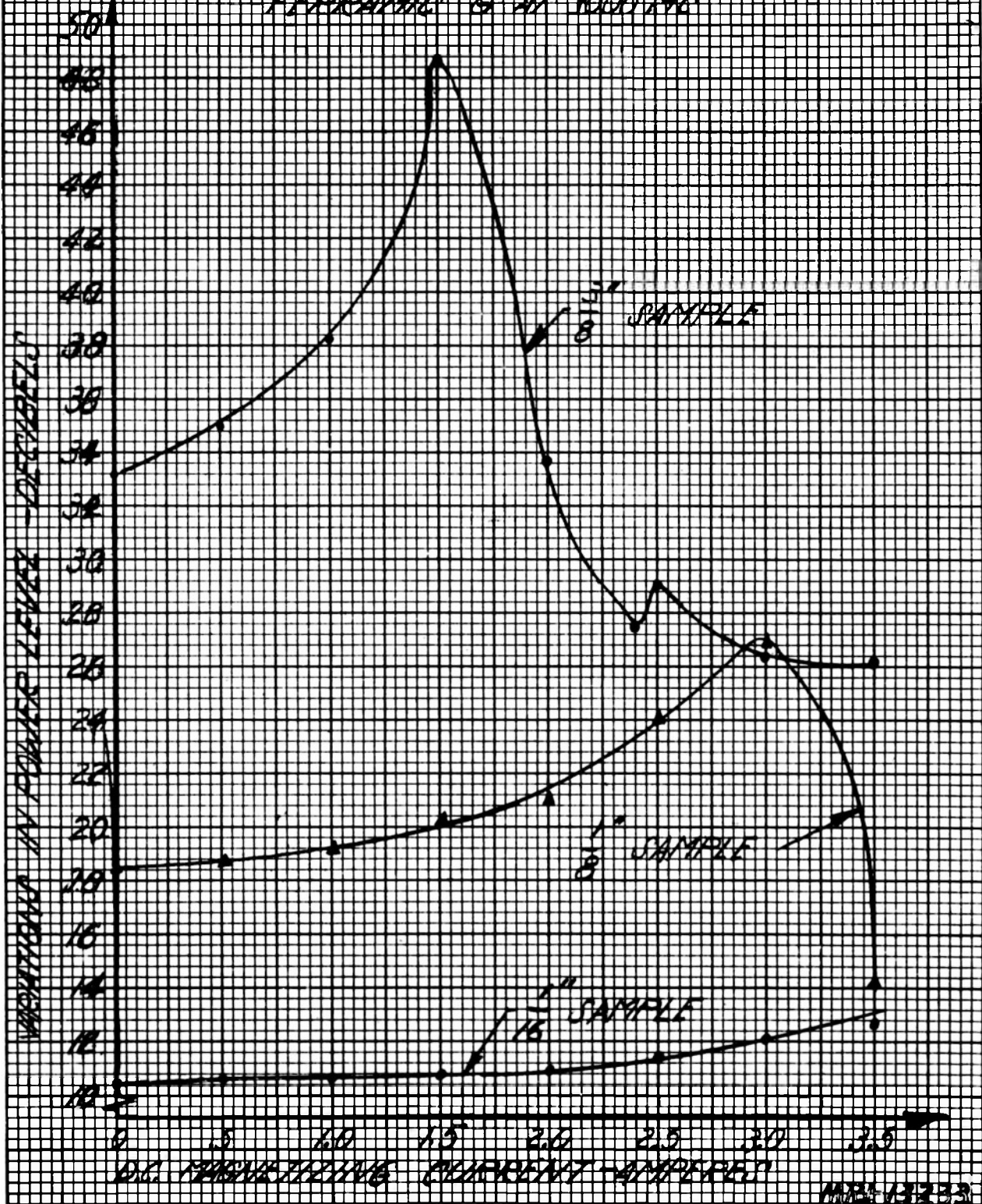

MSA 13233

VARIATIONS IN POWER LEVEL AS A FUNCTION OF
 A.C. MAGNETIZING CURRENT FOR BUTTER LAMINAE
 F-4 AT 3000 MC

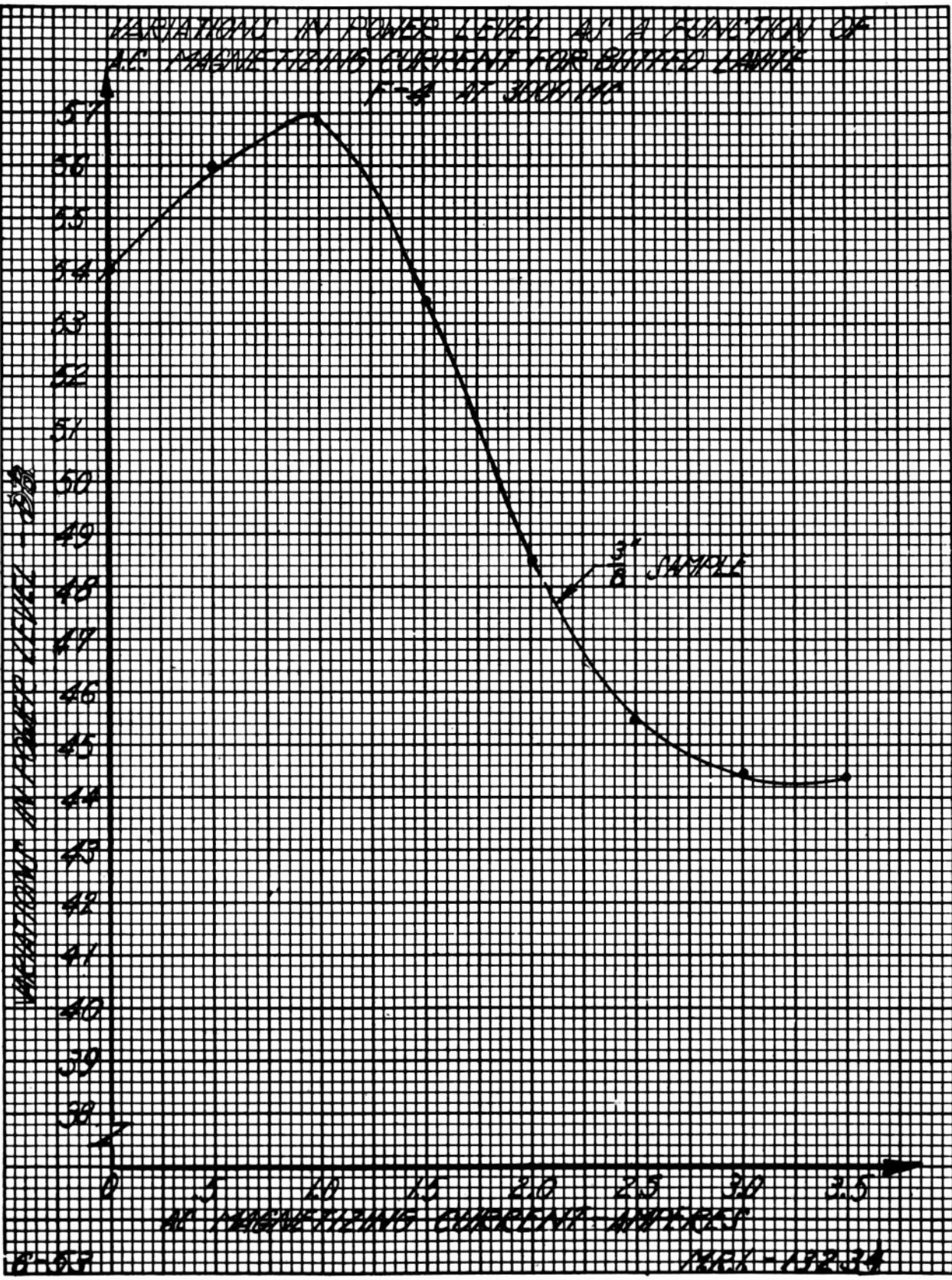

VARIATIONS IN POWER LEVEL AS A FUNCTION OF AC MAGNETIZING CURRENT FOR BUTTED LEAD T F-4 AT 3000 MC

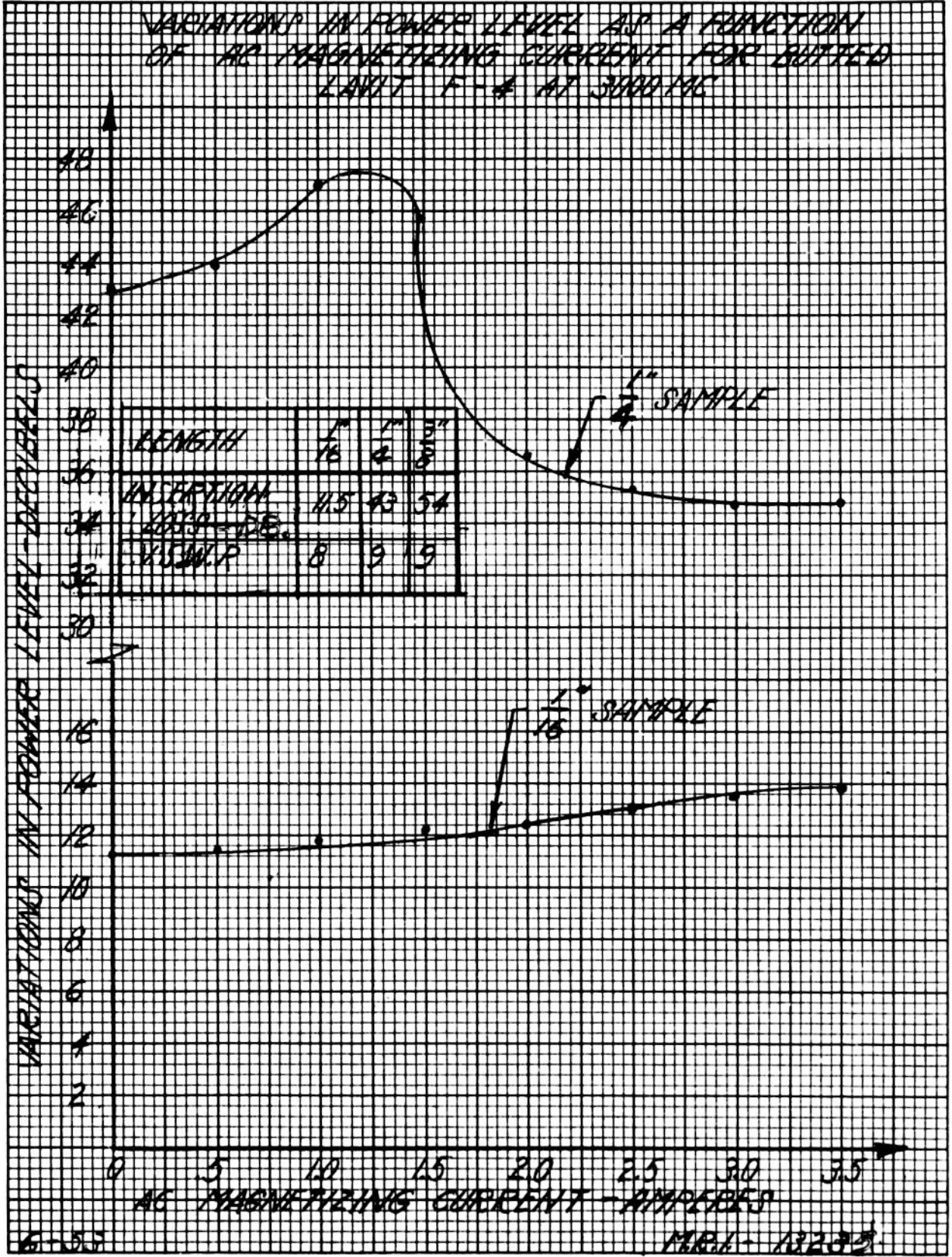

VARIATIONS IN POWER LEVEL AS A FUNCTION OF
D.C. MAGNETIZING CURRENT FOR BUTTED LAMINAE
F-4 AT 3000 MC

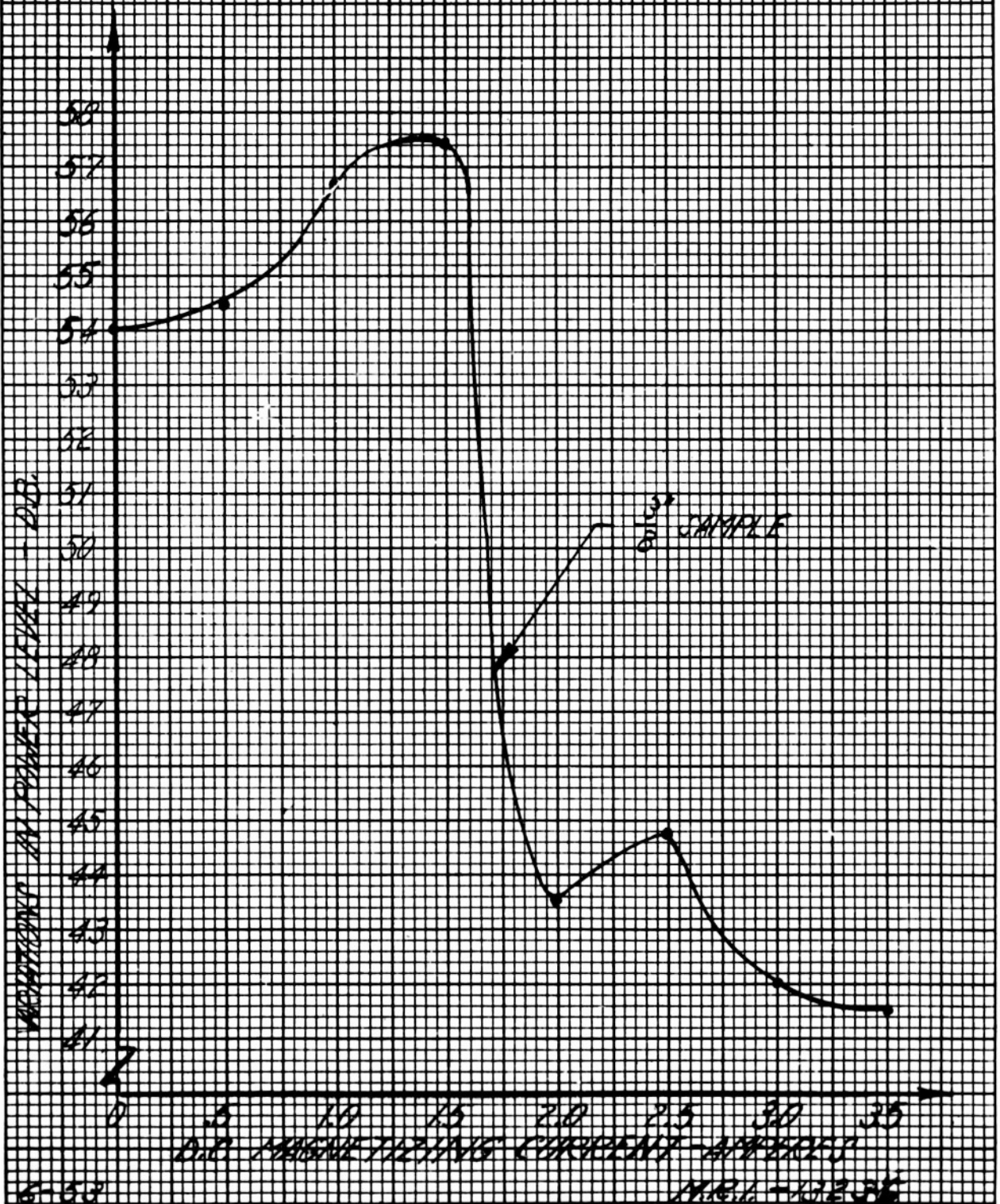

VARIATIONS IN POWER LEVEL AS A FUNCTION OF DC
 MAGNETIZING CURRENT FOR BUFFED LAMINATE
 F-4 AT 3500 MC.

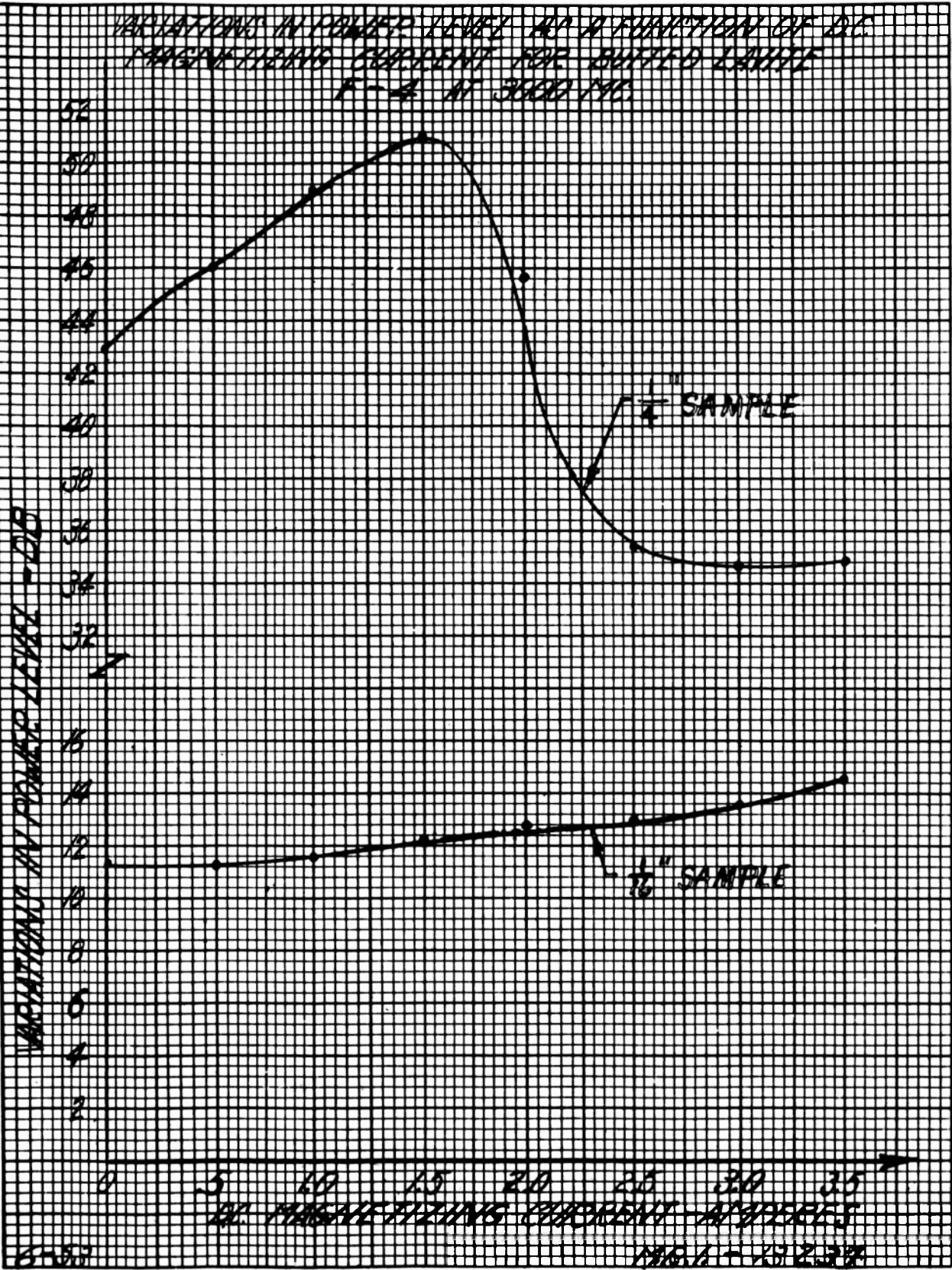

VARIATIONS IN POWER LEVEL AS A
 FUNCTION OF REVERSED D.C. MAGNETIZING
 CURRENT FOR CUTTED POLYIRON
 D AT 2000 MC

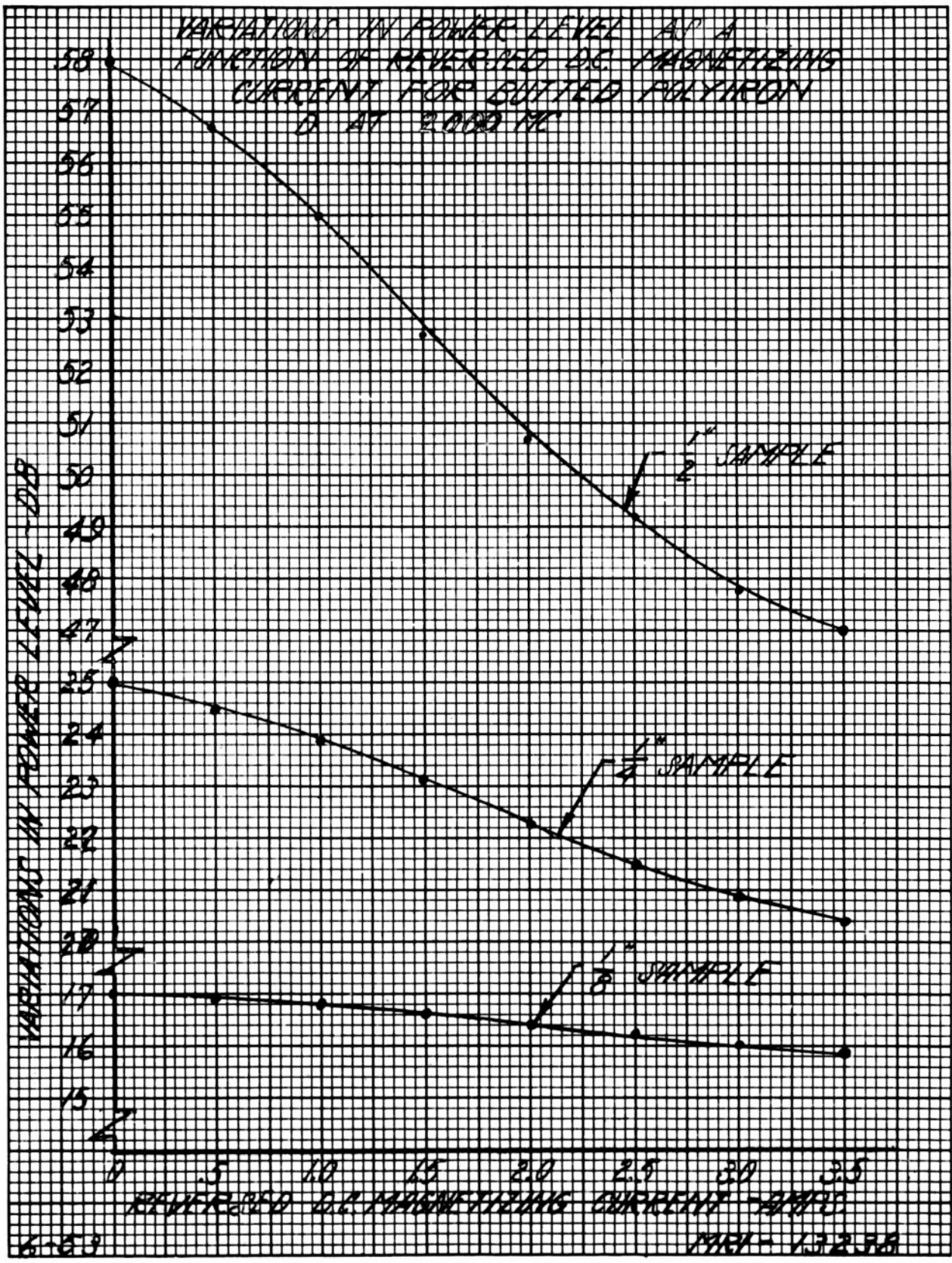

6-53

MRI-13275

VARIATION IN POWER LEVEL AS A
 FUNCTION OF REVERSED DC MAGNETIZING
 CURRENT FOR BUTTED POLYFON D AT
 3000 MC

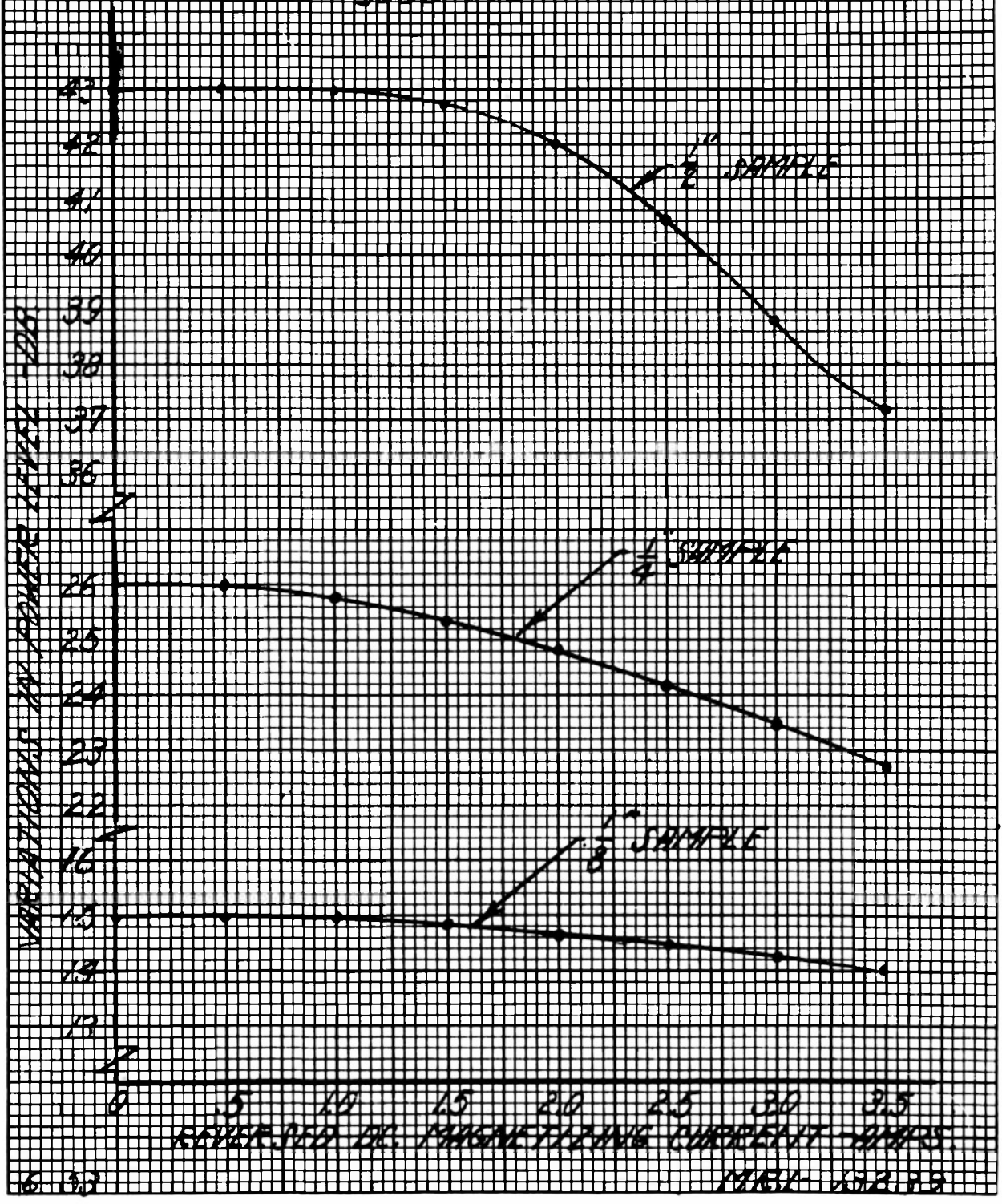

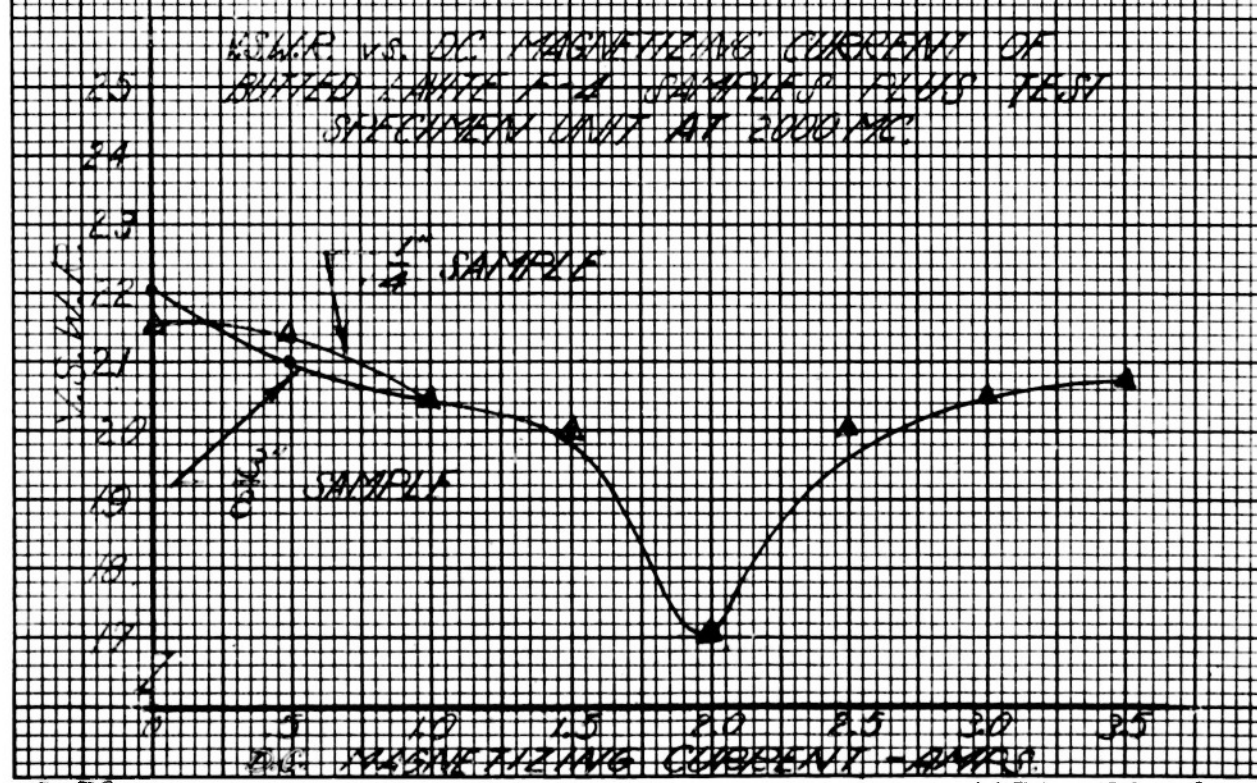
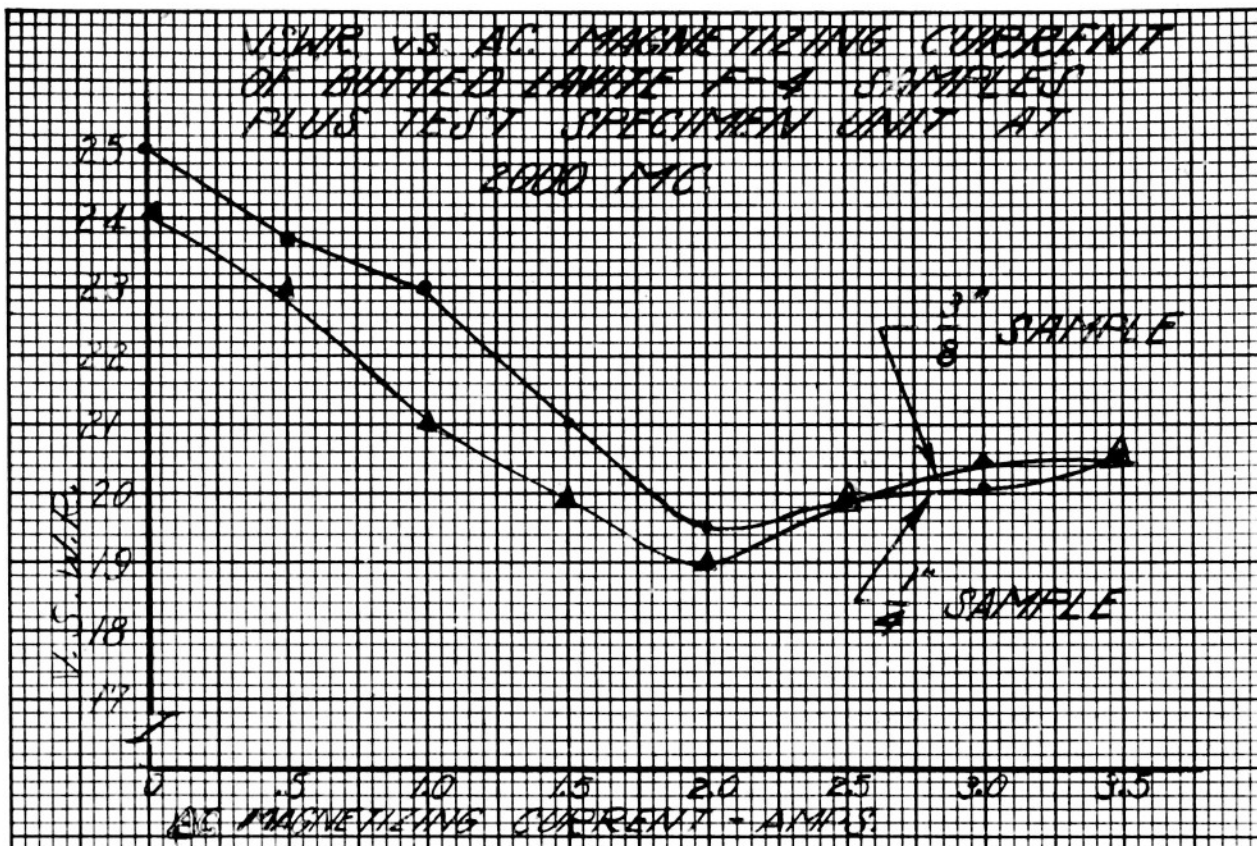

KILN R VS MAGNETIZING CURRENT OF
 BUTTER POLYMERON SAMPLE PLUS
 TEST SPECIMEN UNIT AT 300°C

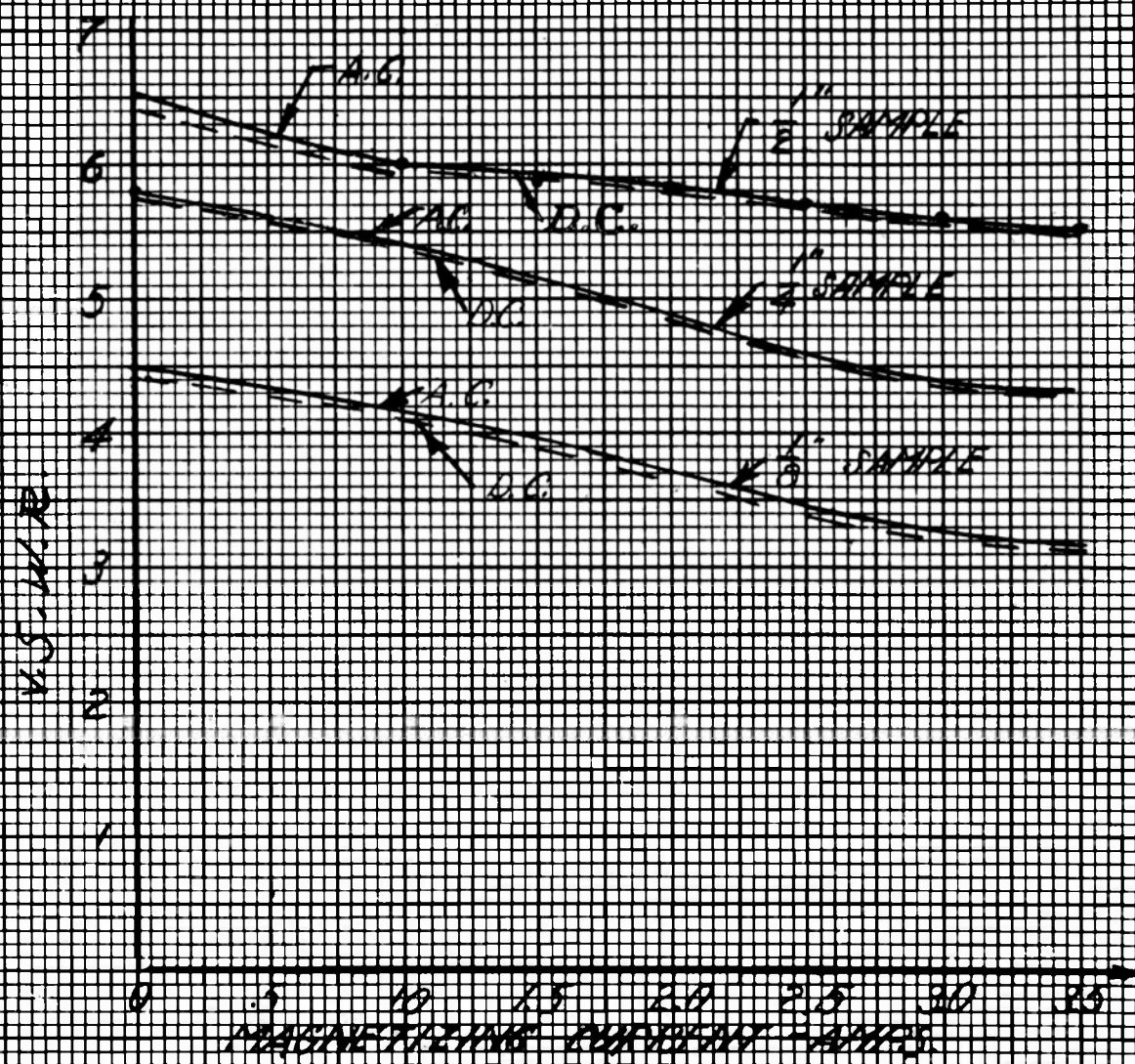

6-5-53

MIRA-3241

VOLTA VS MAGNETIZING CURRENT OF
 BUTTED JAWED F-4 SAMPLE FLUX
 TEST SPECIMEN UNIT AT 3000 P.P.C.

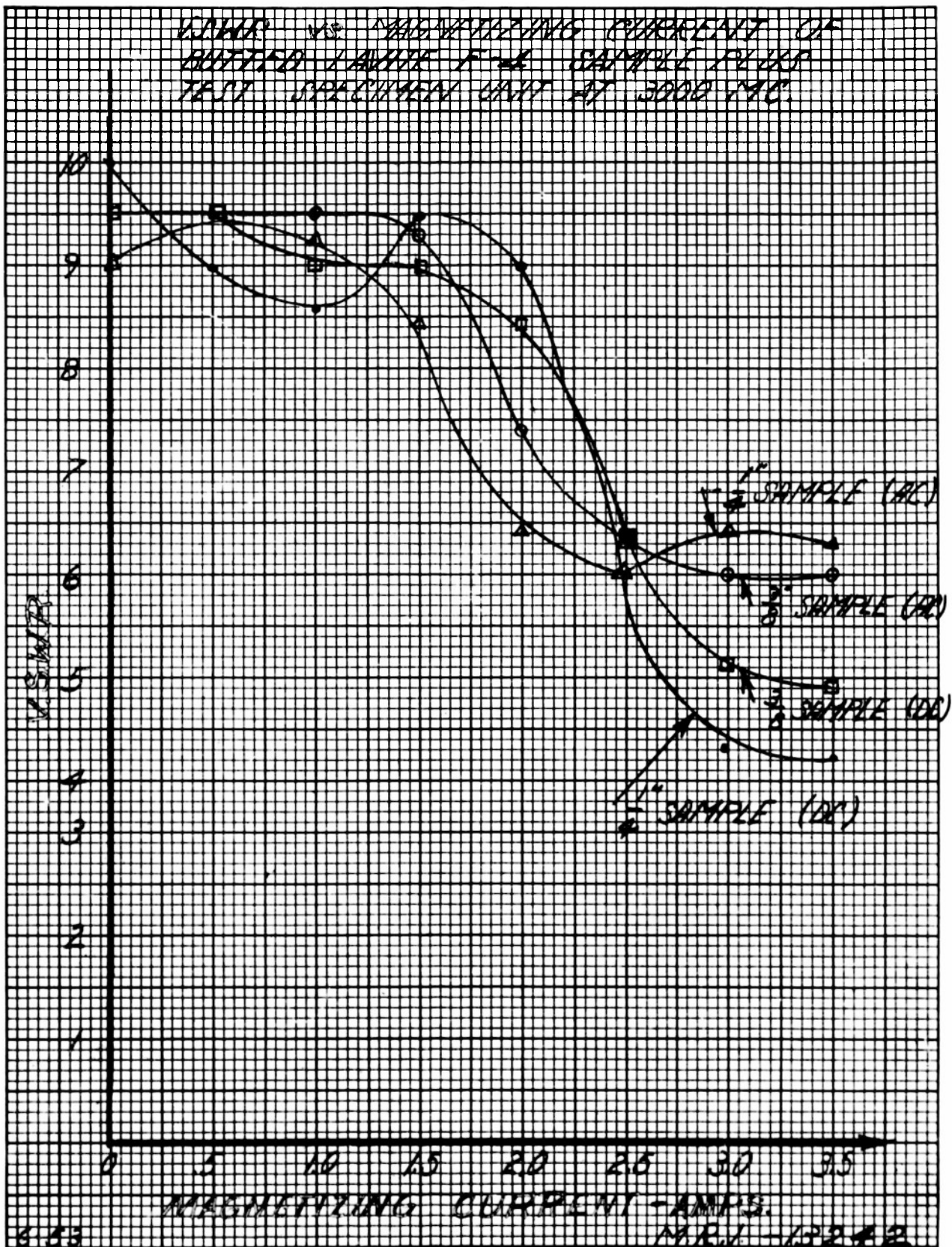

Armed Services Technical Information Agency

Because of our limited supply, you are requested to return this copy WHEN IT HAS SERVED YOUR PURPOSE so that it may be made available to other requesters. Your cooperation will be appreciated.

AD

32562

NOTICE: WHEN GOVERNMENT OR OTHER DRAWINGS, SPECIFICATIONS OR OTHER DATA ARE USED FOR ANY PURPOSE OTHER THAN IN CONNECTION WITH A DEFINITELY RELATED GOVERNMENT PROCUREMENT OPERATION, THE U. S. GOVERNMENT THEREBY INCURS NO RESPONSIBILITY, NOR ANY OBLIGATION WHATSOEVER; AND THE FACT THAT THE GOVERNMENT MAY HAVE FORMULATED, FURNISHED, OR IN ANY WAY SUPPLIED THE SAID DRAWINGS, SPECIFICATIONS, OR OTHER DATA IS NOT TO BE REGARDED BY IMPLICATION OR OTHERWISE AS IN ANY MANNER LICENSING THE HOLDER OR ANY OTHER PERSON OR CORPORATION, OR CONVEYING ANY RIGHTS OR PERMISSION TO MANUFACTURE, USE OR SELL ANY PATENTED INVENTION THAT MAY IN ANY WAY BE RELATED THERETO.

Reproduced by
DOCUMENT SERVICE CENTER
KNOTT BUILDING, DAYTON, 2, OHIO

UNCLASSIFIED