

UNCLASSIFIED

AD NUMBER
AD033173
NEW LIMITATION CHANGE
TO Approved for public release, distribution unlimited
FROM Further dissemination only as directed by Army Ballistic Research Lab., Aberdeen Proving Ground, MD; 20 Sep 99 or higher DoD authority
AUTHORITY
Army Research Laboratory, Security/CI Office ltr., dtd July 28, 2000.

THIS PAGE IS UNCLASSIFIED

UNCLASSIFIED



AD NUMBER

AD-033 173

CLASSIFICATION CHANGES

TO UNCLASSIFIED

FROM CONFIDENTIAL

AUTHORITY

ASTIA Tab No U63-3-5; Sep 1, 1963

19990923054

THIS PAGE IS UNCLASSIFIED

UNCLASSIFIED



AD NUMBER

AD-033 173

NEW LIMITATION CHANGE

TO **DISTRIBUTION STATEMENT - F**

Further dissemination only as directed by Army Ballistic Research
Lab, Aberdeen Proving Ground, MD; 20 Sep 99 or higher DoD
authority

LIMITATION CODE: 5

FROM No Prior DoD Distr Scty Cntrl St'mt Assgn'd

AUTHORITY

DoDD 5230.24, Para f.3.b.; Sep 20, 1999

THIS PAGE IS UNCLASSIFIED

UNCLASSIFIED

AD

33 173

DEFENSE DOCUMENTATION CENTER

FOR

SCIENTIFIC AND TECHNICAL INFORMATION

CAMERON STATION, ALEXANDRIA, VIRGINIA

CLASSIFICATION CHANGED
TO UNCLASSIFIED
FROM CONFIDENTIAL

PER AUTHORITY LISTED IN
ASTIA TAB NO. U63-3-5

DATE 1 SEPT. 63



UNCLASSIFIED

Reproduced From
Best Available Copy

©

NOTICE: When government or other drawings, specifications or other data are used for any purpose other than in connection with a definitely related government procurement operation, the U. S. Government thereby incurs no responsibility, nor any obligation whatsoever; and the fact that the Government may have formulated, furnished, or in any way supplied the said drawings, specifications, or other data is not to be regarded by implication or otherwise as in any manner licensing the holder or any other person or corporation, or conveying any rights or permission to manufacture, use or sell any patented invention that may in any way be related thereto.

**NOTICE: THIS DOCUMENT CONTAINS INFORMATION AFFECTING THE
NATIONAL DEFENSE OF THE UNITED STATES WITHIN THE MEANING
OF THE ESPIONAGE LAWS, TITLE 18, U.S.C., SECTIONS 793 and 794.
THE TRANSMISSION OR THE REVELATION OF ITS CONTENTS IN
ANY MANNER TO AN UNAUTHORIZED PERSON IS PROHIBITED BY LAW.**

UNCLASSIFIED

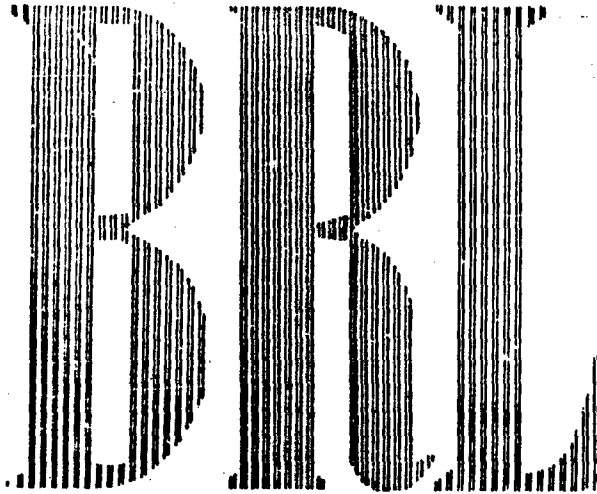

MEMORANDUM REPORT No. 767

Air Blast Measurements Around Moving Explosive Charges

JAMES D. PATTERSON II

JACOB WENIG

DEPARTMENT OF THE ARMY PROJECT No. 503-04-002
ORDNANCE RESEARCH AND DEVELOPMENT PROJECT No. TB3-0112J

BALLISTIC RESEARCH LABORATORIES



ABERDEEN PROVING GROUND, MARYLAND

~~██████████~~ 4AA 41326

UNCLASSIFIED

b. "Initial distribution has been made of this report in accordance with the distribution list contained herein. Additional distribution without recourse to the Ordnance Office may be made to United States military organizations, and to such of their contractors as they certify to be cleared to receive this report and to need it in the furtherance of a military contract."

This document contains information affecting the national defense of the United States within the meaning of the Espionage Laws, Title 18 U. S. C. Sections 793 and 794. The transmission or the revelation of its contents in any manner to an unauthorized person is prohibited by law.

~~CONFIDENTIAL~~

UNCLASSIFIED

BALLISTIC RESEARCH LABORATORIES

MEMORANDUM REPORT NO. 767

March 1954

AIR BLAST MEASUREMENTS AROUND MOVING EXPLOSIVE CHARGES

James D. Patterson II

Jacob Wenig

Department of the Army Project No. 503-04-002
Ordnance Research and Development Project No. TB3-0112J

ABERDEEN PROVING GROUND, MARYLAND

54AA

41326

~~CONFIDENTIAL~~

UNCLASSIFIED



UNCLASSIFIED

TABLE OF CONTENTS

	PAGE
ABSTRACT	3
INTRODUCTION	5
EXPERIMENTAL PROCEDURE	6
Projection of the Charge	6
Detonation of the Charge	8
Measurement of the Blast	8
RESULTS AND FUTURE WORK	14
REFERENCES	15
DISTRIBUTION	16



UNCLASSIFIED

CONFIDENTIAL

BALLISTIC RESEARCH LABORATORIES

MEMORANDUM REPORT NO. 767

JDPatterson/JWenig/ekb
Aberdeen Proving Ground, Md.
March 1954

AIR BLAST MEASUREMENTS AROUND MOVING EXPLOSIVE CHARGES

ABSTRACT

On the basis of a preliminary phase of the experimentation, a tentative comparison is made of the blast at a distance of about 2 1/2 feet from a 3/8 pound sphere of bare explosive of Composition B, detonating both as a stationary charge and at a terminal velocity of approximately 2000 feet/second:

Side - On Blast Parameter	0 ft/sec	Terminal Velocity 2000 feet/second Angular Position from Direction of Flight		
		15°	45°	105°
Peak Pressure, psi	73	109	87	55
Impulse, psi - ms	7.8	14.4	13.0	7.0

The explosive spheres were propelled from a smooth - bore 57mm gun tube using 8 ounces of double base propellant powder. Three ounces of absorbent cotton interspaced between the explosive and the propellant served as the sabot. The explosive was detonated in flight by inducing an electric current in a detonator, located centrally within the explosive, by means of a properly timed pulsed magnetic field.

CONFIDENTIAL

INTRODUCTION

During the course of aircraft vulnerability firings both in this country and in the United Kingdom, and during Swiss firing trials¹ of 20mm Cerlikon ammunition against box structures, it has been noticed that air blast damage to targets is increased in the direction of motion of a detonating shell and is reduced in the opposite direction. Several possible qualitative explanations^{2,3} of the dependence of damage on shell motion are (1) the strength of the air shock formed about an exploding shell, being dependent on ambient pressure conditions, will be enhanced about the nose (immediately behind the bow wave or ballistic shock) where the ambient pressure is highest, and weakened behind the base, where the ambient pressure is lowest and (2) the air shock will be stronger in the direction from which air flows into the shock.

Some investigators have formulated simple mathematical models of the problem. Thornhill and Hetherington⁴ have solved the characteristic Riemann integral for plane flow simultaneously with the three Rankine - Hugoniot conservation equations and also with the polytropic gas equation of state. From this they obtained initial shock velocities for various ambient air wind velocities and concluded that the initial shock velocities in winds can be obtained approximately from initial shock velocities in still air by simple vectorial addition. Cole⁵ has shown by means of linearized acoustic equations of flow that pressure is enhanced in the direction of motion of an exploding shell. These studies serve to confirm theoretically the experimental observations that blast is enhanced in the direction of motion.

In order to properly evaluate the effectiveness of blast type warheads against targets, quantitative data are needed of the peak pressures and impulses in airblast waves around moving explosives. It was felt at the Ballistic Research Laboratories that such data could be obtained directly by

- a. Projecting an explosive at a desired terminal velocity.
- b. Detonating the explosive at a desired position in space, and
- c. Measuring the blast around the moving detonation of explosive.

It has taken about one and a half years to resolve all the difficulties of each of these experimental phases. At the time that the conclusion was reached that data on moving charges could be obtained by this procedure, it also became evident that certain improvements in the installation of the equipment would result in a more effective means of procuring the data. Before such improvements were made, however, it seemed desirable to get blast data for at least one condition: 3/8 pound explosive, 2000 ft/sec terminal velocity, at a distance of 2 1/2 feet from point of detonation. The blast evaluation was made on the basis of a comparison of the blast from a moving charge to that from a stationary charge.

CONFIDENTIAL

EXPERIMENTAL PROCEDURE

Projection of the Charge

Since the effect to be investigated pertains primarily to bombs and missiles which cause damage by blast, it is desirable to have at most a relatively light metal case on the explosive charge. Even a light case, however, produces fragments of sufficient size and velocity to interfere with the recording of the blast wave; ballistic waves set up in the air by passing fragments are recorded by blast gages and obscure the record. It was decided, therefore, to try using a bare charge of explosive. A spherical shape was chosen to avoid complications due to initial asymmetry of the blast. There remained the selection of the weight and the means of projection.

Ideas on the use of air guns, magnetic devices, etc., were abandoned in favor of the use of a conventional cannon for the propelling device. The large surplus of 57mm guns, M1, determined the selection of caliber, with the result that the weight of 3/8 pound for the explosive was used. This charge, in the form of a sphere, just fits into a 2.293-inch diameter hole, the final diameter of the 57mm gun bore when reamed out smooth.

Now that the 57mm gun and the 3/8 pound spherical charge had been chosen, the next problem was to project the charge from the gun. This involved the selection of the best performing amount and composition of propellant powder as well as the proper type of sabot to cradle the charge. After trying various types of (both slow and fast burning) propellant powders, with various web sizes and numbers of perforations, and after using different loading weights, a standard 37mm gun propellant powder was chosen because of its uniformity of burning when using an 8-ounce load. This propellant is single perforated, and double based, and has a web size of 0.031 inches. A standard Army T-51 electric primer in an M 23-A2 57mm cartridge case was used to initiate the propellant. Cardboard discs and tubing above the powder confined the powder to the bottom of the cartridge case and thus provided for more uniformity in burning and final velocity of projection by preventing initial scattering of the powder. Spherically shaped balls of plaster of Paris was propelled for this part of the tests.

Having selected the propellant, it was now necessary to design a sabot that would protect the explosive charge from shattering within the gun tube and also that would disengage itself from the charge when outside the gun tube. This by far posed the most difficult part of the experimentation. Many types were designed and tested. Some were made from bakelite, aluminum, balsa wood, cellotex, sponge and solid rubber, and combinations of these. However, none of these prevented the charge from shattering mechanically in the tube.*

* At no time did a charge explode in the tube.

CONFIDENTIAL

Finally, absorbent cotton, consisting of three separate wads which weighed approximately 3 ounces combined, was used as a sabot, yielding a terminal velocity of about 2000 feet/second. This material gave good results, but further investigation was indicated since 50 percent of the charges shattered.

At this stage of the development the 3/8 pound charge was being cast from 50/50 pentolite. In an effort to reduce the percentage of rounds shattering an explosive having greater strength was sought (see Table I). Of the various explosives tested, reclaimed* Composition "B" proved to be the strongest and accordingly was used. The break-up was reduced to about 1 in 8. A Potter electronic counter was used to measure the charge velocity. The breaking of two wire screens by the passing explosive charge triggered the counter. The velocity of a moving charge was 1980 feet/second \pm 3 percent (standard deviation). This velocity was believed to be great enough to show at least some effect of motion on blast.

TABLE I

TYPES OF HE TESTED FOR BREAK-UP		
Types of HE Tested	No. of Rounds	% Break-up
Pentolite w/M-36 Det. & Coil	42	50.0 %
PTX-2 w/M-36 Det. & Coil	3	100.0 %
Cyclotol w/M-36 Det. & Coil	2	100.0 %
Composition "B" (Reclaimed), Pentolite Center w/M-36 Det. & Coil	14	57.1 %
Composition "B" (New), Pentolite Center w/M-36 Det. & Coil	3	62.5 %
Composition "B" (Reclaimed), w/M-36 Det. & Coil	37	13.5 %
Composition "B" (Reclaimed), w/M-18 Booster, M-36 Det. & Coil	4	25.0 %
Composition "B" (Reclaimed, Water Cooled), w/M-18 Booster, M-36 & Coil	23	39.0 %

* Reclaimed Composition "B" consists of a mixture of RDX, TNT, and a very small percentage of paraffin desensitizer. This mixture is aged and melted more than once, thus being designated as reclaimed.

CONFIDENTIAL

Detonation of the Charge

The second phase of the experimentation consisted of devising a way to detonate the charge, while in motion in free air, at a desired position.

Inductive pickup by a fine coil of wire bridged to a detonator (M-36) was used as a source of energy for detonating the moving charge (a steady magnetic field would have proved to be impracticable). At the instant the explosive enters a stationary coil of copper wire a "pulsed" strong magnetic field is formed by discharging a large condenser through the coil. The stationary coil is composed of three turns of number 4 copper wire approximately 7 1/2-inches in diameter. The coil bridged to the detonator consists of ten feet of number 28 enamel or "formex" coated copper wire wound on an iron nail.

The trigger mechanism for discharging the condensers is the breakage by the passing explosive of a fine wire screen. Figure 1 is a schematic diagram of the magnetic pulser. The operation of the unit is as follows: When the wire is broken, a positive voltage pulse is applied to the grid of the 2D21 thyratron which causes it to fire. The output of the 2D21 is then applied to the grids of the paralleled 5C22 hydrogen thyratrons, which causes them to conduct. The charged condensers (C_1 and C_2) discharge through the thyratrons and through the coil L_2 . This causes a large oscillating magnetic field to be built up in coil L_2 . The coil which is in the moving charge (and now in the field of L_2) develops a large induced voltage. Using a dummy detonator with bridged coil it was found that the peak current induced is about 30 amperes, more than enough to detonate a M-36 cap. To insure high-order detonation of the explosive an M-18 booster was abutting the M-36 cap. It is noted that unfavorable orientation of the coil in the moving charge with respect to L_2 may cause a low induced voltage and hence failure to detonate.

Measurement of the Blast

The standard method of measuring blast was used, namely, measurement of the time histories of the shock wave about the explosive charge by the use of piezoelectric gages and associated oscillographic recording equipment. A block diagram of the equipment is shown in Figure 2.

The placement of the gun, gages, and cameras is shown in Figure 3. A point 54 feet down range and 2.3 feet from the ground was chosen as the point of detonation. Five piezoelectric gages were placed at angular positions as shown in Figure 3 in the same horizontal plane as the point of detonation and equidistant from the point. The centerlines of the gages coincided with radial lines from the point of detonation and were directed towards the point of detonation. The distance from the point of detonation to the gage was set at 2.36 feet which for the static detonation of the charge was predicted to yield a peak pressure of approximately 100 pounds/square inch and a positive impulse of approximately 10 pound ms/square inch. For the comparative firings, emphasis was placed on finding the ratio of peak pressure or impulse from a moving charge as compared to that from a static charge. These ratios have the advantage of

CONFIDENTIAL

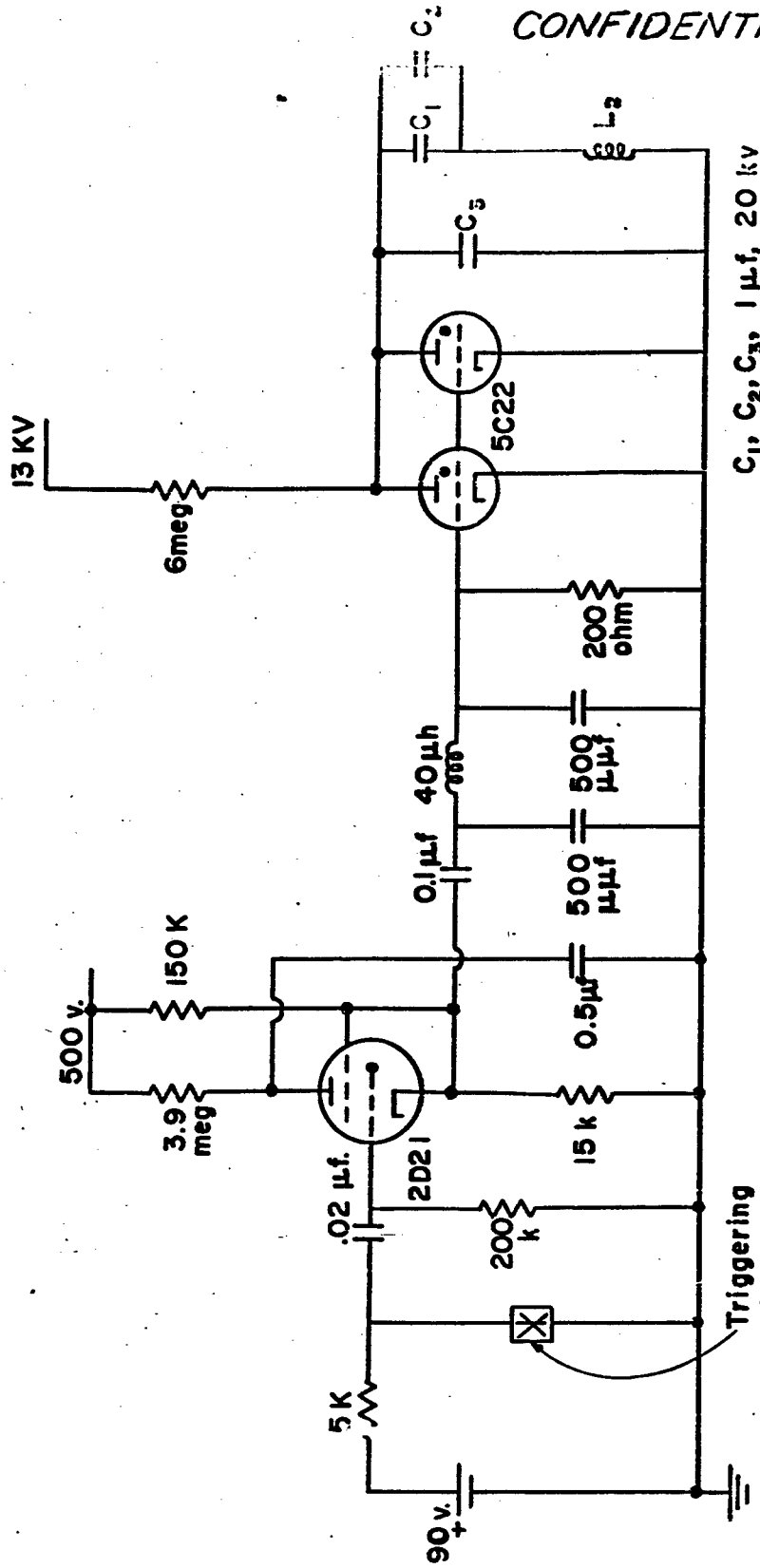

C₁, C₂, C₃, 1 μf, 20 kv

CONFIDENTIAL

Figure 1

Schematic of "Magnetic Pulser"

CONFIDENTIAL

BLOCK DIAGRAM OF RECORDING EQUIPMENT

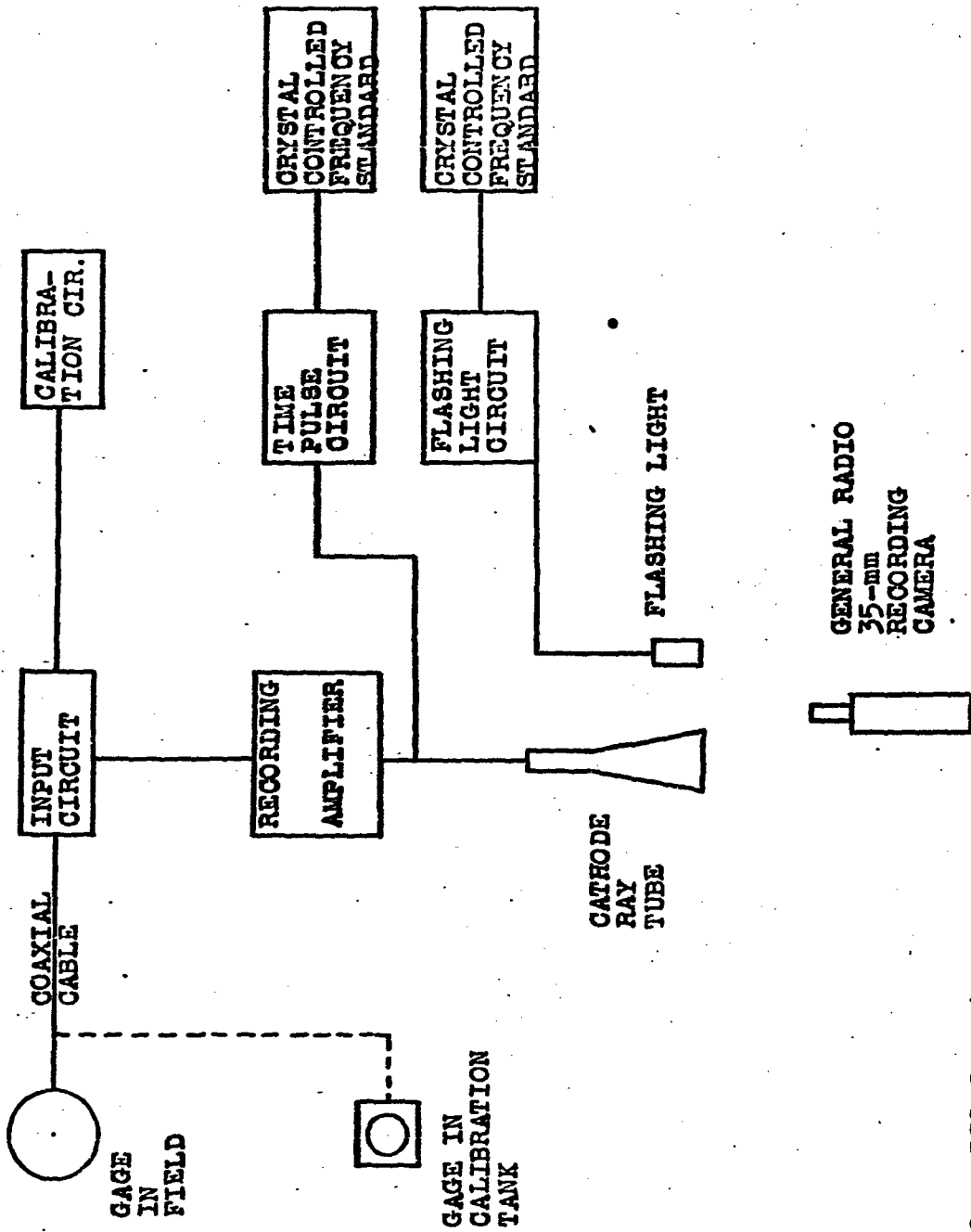

Extracted from BRL Report
No. 661

Fig. 2

CONFIDENTIAL

CONFIDENTIAL

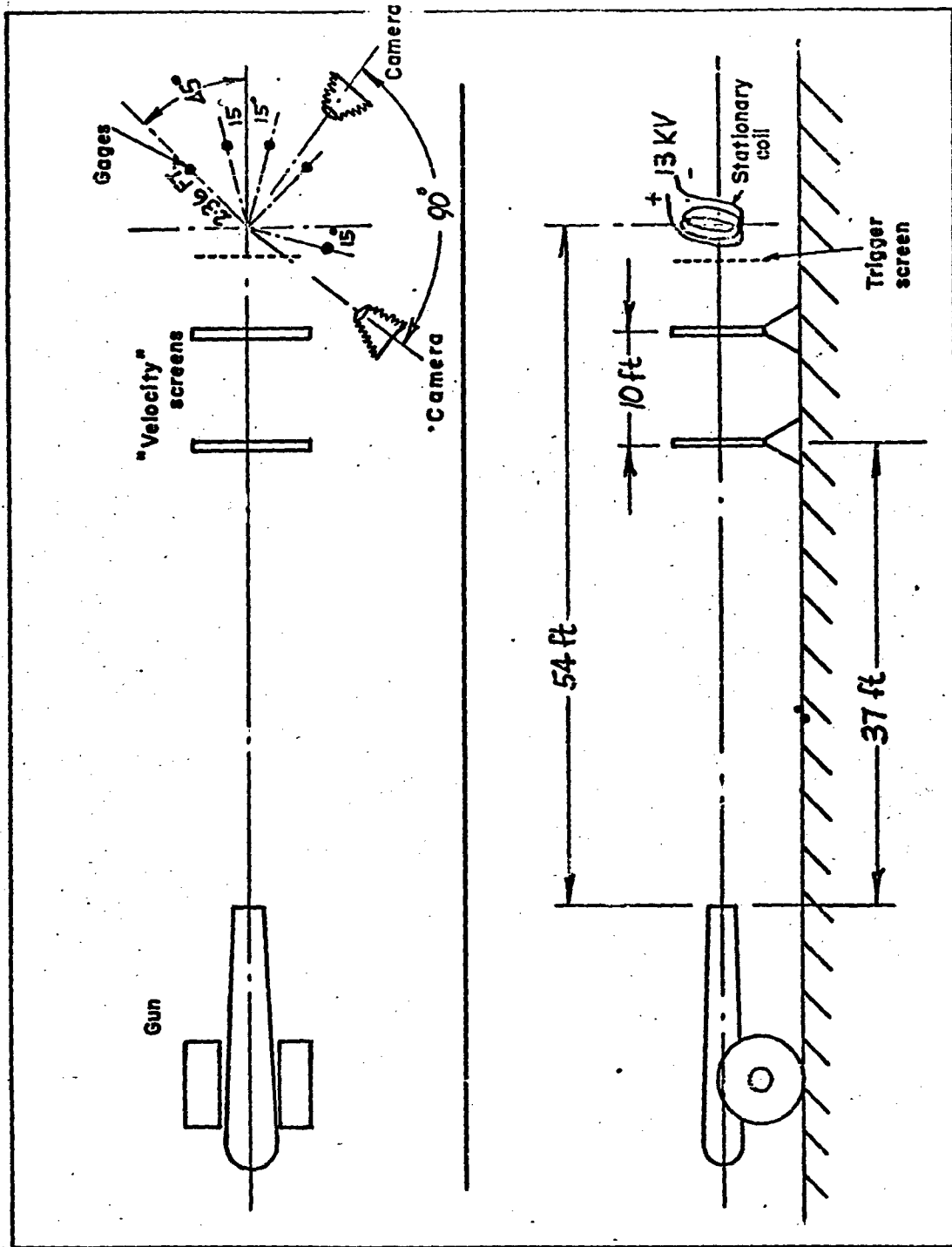

Fig. 3

CONFIDENTIAL



FIGURE 4

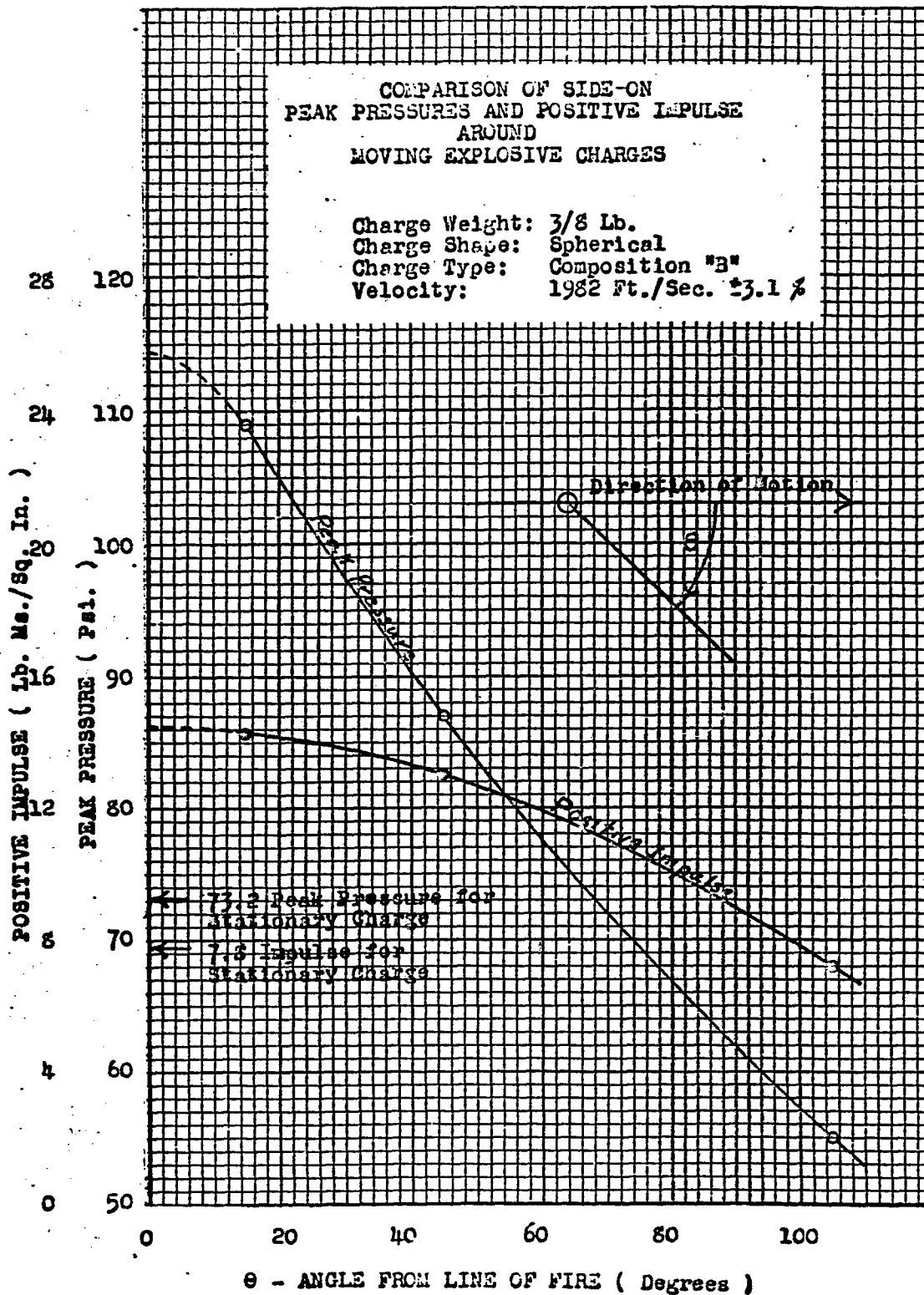

Fig. 5

CONFIDENTIAL

being independent of gage calibration. Care was taken to fire alternately moving and static charges to minimize the effects of changing atmospheric conditions and possibly other uncontrollable factors.

Although the piezoelectric gages were arranged equidistant from the intended point of detonation, the charge did not always detonate at the desired position. To locate the actual point of detonation in space, two Rapatronic ⁶ shuttered cameras positioned in the same horizontal plane as the gages and 90° apart were used to record the point of detonation photographically.

RESULTS AND FUTURE WORK

Figure 4 is a typical photograph taken with the Rapatronic camera of the moving spherical charge detonated within the stationary coil. The average results of four rounds which detonated at the approximate intended point are shown diagrammatically in Figure 5. The figure is an attempt to generalize a limited amount of data and is a plot of peak pressure and impulse versus the angle from the direction of motion of the charge. Although this information is certainly not conclusive it does seem sufficient to show that an effect on blast does exist as a result of the velocity of the charge at detonation.

It is planned to investigate the blast contours about moving charges more thoroughly with larger charge weights, different velocities, and in a wider range of directions from the moving charge.

James D. Patterson II
JAMES D. PATTERSON II

Jacob Wenig
JACOB WENIG

CONFIDENTIAL

REFERENCES

1. Oerlikon Machine Tool Works, Zurich-Oerlikon, Switzerland, Brochure No. 950, "Target-Velocity and Blasting Effect of 'Oerlikon' 20mm. Ammunition."
2. NOL Memorandum No. 10983, "Charge Velocity and Blast Effect - Comments on Oerlikon Report," H. G. Snay, 1 July 1950 (C).
3. BRL Report No. 721, "The Effect of Atmospheric Pressure and Temperature on Air Shock," J. Dewey and J. Sperrazza, May 1950.
4. ARE Memo 6153, "Some Notes on Explosions of Moving Charges," C. K. Thornhill and R. Hetherington, April 1953.
5. Rand Report RM-848, "Note on Directional Effect of Pressure Field of Moving Blast," J. D. Cole, 9 June 1952.
6. BRL Report No. 791, "The Application of the Faraday-Magneto Effect to the Optical Study of Explosive and Shaped Charge Mechanisms," R. Bailey and M. Sultanoff, November 1951.

UNCLASSIFIED

DISTRIBUTION LIST

<u>No. of Copies</u>	<u>Organization</u>	<u>No. of Copies</u>	<u>Organization</u>
10	Chief of Ordnance Department of the Army Washington 25, D. C. Attn: ORDTB - Bal Sec.	1	Superintendent Naval Postgraduate School Monterey, California
10	British - ORDTB for Distribution Of interest to: Mr. G. Simm, R. A. E.	9	Chief, Bureau of Aeronautics Department of the Navy Washington 25, D. C. Attn: Armament Div. - 2 cys Research Div. - 1 cy Design Elements Div. 1 cy Evaluation Div. - 1 cy Military Reg. Div. - 1 cy Aircraft Div. - 1 cy Lower Plant Div. - 1 cy
4	Canadian Joint Staff - ORDTB for distribution		
4	Chief, Bureau of Ordnance Department of the Navy Washington 25, D. C. Attn: Re3 Re2 - Mr. Strollo Re8 ReXa	1	Commanding Officer U. S. Naval Ordnance Laboratory Corona, California Attn: Documents Library
4	ASTIA Reference Center Library of Congress Washington 25, D. C.	1	Commander Naval Air Development Center Johnsville, Pennsylvania
1	Commander Naval Proving Ground Dahlgren, Virginia	1	Commander Air Proving Ground Command Eglin Air Force Base, Florida Attn: Adj/Technical Branch
2	Commander Naval Ordnance Laboratory White Oak Silver Spring 19, Maryland	2	Director Air University Library Maxwell Air Force Base, Ala.
2	Commander U. S. Naval Ordnance Test Station Inyokern P. O. China Lake, California Attn: Technical Library	5	Chief of Staff U. S. Air Force Washington 25, D. C. Attn: AFDD-AC - (2 cys) DCS/O - Operation Analysis Div. AFDRQ
1	Chief of Naval Operations Department of the Navy Washington 25, D. C. Attn: Op 374 Dr. J. Steinhardt	1	Director, Project Rand Department of the Air Force 1700 Main Street Santa Monica, California

UNCLASSIFIED

UNCLASSIFIED

DISTRIBUTION LIST

<u>No. of Copies</u>	<u>Organization</u>	<u>No. of Copies</u>	<u>Organization</u>
5	Commanding General Wright Air Development Center Wright-Patterson Air Force Base, Ohio Attn: WCOSI WCNS WCLGE WCNE WCOWP	5	Director Armed Services Technical Information Agency Documents Service Center Knott Building Dayton 2, Ohio Attn: DSC-SA
1	Headquarters U. S. Air Force Directorate of Research and Development Washington 25, D. C. Attn: Armament Div. (AFDRD-AR/1)	1	Chief of Ordnance Department of the Army Washington 25, D. C. Attn: Col. James H. Shea
1	Chief, Air Technical Intelligence Center Wright-Patterson Air Force Base, Ohio Attn: Associated Equipment Section, ATIAS	3	Commanding General Picatinny Arsenal Dover, New Jersey
1	Commanding General Continental Air Command Mitchell Air Force Base, New York	1	Commanding Officer Frankford Arsenal Philadelphia 37, Penna.
2	Commanding General Strategic Air Command Offutt Air Force Base Omaha, Nebraska	1	President Army Ground Force Board No. 4 Fort Bliss, Texas
1	Commanding General Air Defense Command Mitchell Air Force Base, New York	1	Commandant Antiaircraft and Guided Missile Branch of the Artillery School Fort Bliss, Texas
1	Commanding General Tactical Air Command Langley Air Force Base, Va.	2	Operational Research Office Department of the Army 6410 Connecticut Avenue Chevy Chase, Maryland
1	Commander Research & Development Command U. S. Air Force P. O. Box 1395 Baltimore, Maryland	1	Director Weapons System Evaluation Group Office, Secretary of Defense The Pentagon Washington 25, D. C.
		1	National Advisory Committee for Aeronautics 1724 F. St. N. W. Washington 25, D. C. Attn: Chief, Office of Aeronautical Intelligence

UNCLASSIFIED

UNCLASSIFIED

DISTRIBUTION LIST

<u>No. of Copies</u>	<u>Organization</u>	<u>No. of Copies</u>	<u>Organization</u>
1	Army Ordnance Representative NOTS Annex 1030 E. Green Street Pasadena, California	1	Institute for Air Weapons Research University of Chicago Chicago 37, Illinois Attn: Dr. W. Barak
1	BuAer Representative, USN Douglas Aircraft Co., Inc. El Segundo Plant El Segundo, California		THRU: Commanding Officer Mid Central Air Procurement District 165 N. Canal Street Chicago 15, Illinois
1	Project Thor Institute for Cooperative Research 2229 N. Charles Street Baltimore, Maryland	1	Cornell Aeronautical Lab., Inc. 4455 Genesee Street Buffalo 21, New York
	THRU: Naval Inspector of Ord. Applied Physics Lab. 8621 Georgia Ave. Silver Spring, Maryland		THRU: Bureau of Aeronautic Representative Cornell Aeronautical Laboratory, Inc. P. O. Box 235 Buffalo 21, New York
1	Applied Physics Laboratory 8621 Georgia Avenue Silver Spring, Maryland	1	Mr. E. F. Burton Chief Engineer Douglas Aircraft Co. Santa Monica, California Attn: Mr. R. W. Koster
	THRU: Naval Inspector of Ord. Applied Physics Lab. 8621 Georgia Ave. Silver Spring, Maryland		THRU: Air Force Plant Rep- resentative Douglas Aircraft Co. Santa Monica, California
1	General Electric Company Aeronautics and Ordnance Systems Division Schenectady 5, New York Attn: H. C. Page	1	University of Minnesota Institute of Technology Department of Aeronautical Engineering Rosemount Research Laboratory
	THRU: Resident Ordnance Officer Project HEWES Campbell Avenue Plant General Electric Co. Schenectady 5, New York		THRU: District Chief Chicago Ord. District 209 W. Jackson Blvd. Chicago 6, Illinois

UNCLASSIFIED

AD-033 173

Rec'd
8/3/2000



DEPARTMENT OF THE ARMY
UNITED STATES ARMY RESEARCH LABORATORY
ABERDEEN PROVING GROUND, MARYLAND 21005-5066

REPLY TO
THE ATTENTION OF

AMSRL-CS-10-SC (380)

28 July 2000

MEMORANDUM FOR Defense Technical Information Center, ATTN:
DTIC-BCS, 8725 John J. Kingman Road Suite 0944,
Ft. Belvoir, VA 22060-6218

SUBJECT: Distribution Statement for BRL Memorandum Report No. 767

1. Reference: Ballistic Research Laboratories Memorandum Report No. 767, "Air Blast Measurements around Moving Explosive Charges", by J. Patterson II and J. Wenig, March 1954.

2. The correct distribution statement for the referenced report is:

Approved for public release; distribution is unlimited.

3. Request that you mark your copy of the report with this distribution statement. Our action officer is Mr. Douglas J. Kingsley, telephone 410-278-6960.

BENJAMIN E. BRUSQ
Team Leader, Security/CI Office

