

UNCLASSIFIED

AD NUMBER

AD034994

CLASSIFICATION CHANGES

TO: unclassified

FROM: confidential

LIMITATION CHANGES

TO:
Approved for public release; distribution is unlimited.

FROM:
Distribution authorized to U.S. Gov't. agencies and their contractors;
Administrative/Operational Use; 27 JUL 1953.
Other requests shall be referred to Naval Ordnance Lab., White Oak, MD.

AUTHORITY

31 Jul 1965, DoDD 5200.10; USNOL ltr dtd 29 Aug 1974

THIS PAGE IS UNCLASSIFIED

AD NO. 34194
ASTIA FILE CO

NAVORD REPORT 2830

INVESTIGATION OF PREMATURES EXPERIENCED
IN MAJOR CALIBER PROJECTILES

27 JULY 1953



035296

U. S. NAVAL ORDNANCE LABORATORY
WHITE OAK, MARYLAND

54AA-20387

CONFIDENTIAL

NAVCRD Report 2830

27 July 1953

Under Task NOL-Re2b-3-1-53, the Naval Ordnance Laboratory was asked to investigate the intermediate and major caliber pre-matures experienced in Naval Services since June 1950. The cause is described in detail herein, and the remedial action proposed in this report permits use of existing stocks of naval ammunition with minimum reworking.

EDWARD L. WOODYARD
Captain, USN
Commander

S. W. Booth
S. W. BOOTH
By direction

Reproduced

FROM LOW CONTRAST COPY.

NAVORD Report 2830

27 July 1953

Under Task NOL-Re2b-3-1-53, the Naval Ordnance Laboratory was asked to investigate the intermediate and major caliber pre-matures experienced in Naval Services since June 1950. The cause is described in detail herein, and the remedial action proposed in this report permits use of existing stocks of naval ammunition with minimum reworking.

EDWARD L. WOODYARD
Captain, USN
Commander

S. W. Booth
S. W. BOOTH
By direction

NOTICE: THIS DOCUMENT CONTAINS INFORMATION AFFECTING THE NATIONAL DEFENSE OF THE UNITED STATES WITHIN THE MEANING OF THE ESPIONAGE LAWS, TITLE 18, U.S.C. SECTIONS 793 and 794. THE TRANSMISSION OR THE REVELATION OF ITS CONTENTS IN ANY MANNER TO AN UNAUTHORIZED PERSON IS PROHIBITED BY LAW.

CONFIDENTIAL
NAVORD Report 2830

REFERENCES

- a. NOL Memorandum 9038 of 8 May 1947
- b. NAD, Crane, Indiana Conf spd ltr NF1-18/X1-1/1(02089) of 20 Dec 1951 to BuOrd (Qc-2)
- c. NAD, Crane, Indiana Conf spd ltr NF1-18/X1-1(01909) of 14 Jan 1952 to BuOrd (Qc2)
- d. NAND, Seal Beach, Calif. Conf ltr O-41 of 31 Jan 1952 to BuOrd
- e. BuOrd Conf ltr S78-1(117) Ser 35058 of 6 Mar 1952 to NAD, Crane, Indiana
- f. BuOrd Conf ltr S78-1(54) Ser 37890 of 17 Apr 1952 to NOL
- g. NOL Restr ltr EN6-27/S78-1(P-449) of 21 Oct 1946 to BuOrd
- h. NFG Conf ltr S78-1(25) L5-2(4) BPO 64656 to BuOrd
- i. BuOrd Restr spd ltr Re2b-JJSD:bjn of 8 Sept 1953 to NOL (NP/NOL/X1-1(3198))

CONFIDENTIAL
NAVORD Report 2830

CONTENTS		Page
I.	Introduction.....	1
	A. Operation of Mk 48 Base Fuze.....	1
	B. Preliminary Studies.....	2
II.	Laboratory Explorations - Investigation of Prematures	4
	A. Basic Pressure Tests.....	4
	B. Description of Dynamic Pressure Pulse Generator..	4
	C. Static Functioning Tests.....	5
	D. Measurements of Leakage Pressures.....	6
	E. Description of Instrumentation for Pressure Measurements.....	6
	F. Conclusions From Pressure Measurements.....	7
III.	"O"-Ring Gas Seal to Prevent Prematures.....	8
	A. Description of the "O"-Ring Modification In Preventing Gas Leakage.....	8
	B. Evaluation of the "O"-Ring Seal.....	8
IV.	Field Firing Tests - Investigation of Prematures.....	10
	A. Introduction.....	10
	B. Mk 28 Base Fuze.....	11
	C. Mk 48 Base Fuze.....	12
	D. Summary of Field Firing Data.....	13
V.	Investigation of Prematures Caused by Side Entry of Gases.....	14
	A. Laboratory Pressure Tests.....	14
VI.	Conclusions.....	15

CONFIDENTIAL
NAVCOR Report 2830

ILLUSTRATIONS		Page
Figure 1.	General Arrangement of Mk 48 Base Fuze Showing Modifications to Induce Prematures.....	30
Figure 2.	Dynamic Pressure Pulse Generator with Mk 48 Base Fuze.....	31
Figure 3.	Pressure Pulse Characteristics.....	32
Figure 4.	Effects of Gas Erosion on a Normal Lead Washer Assembled in a Mk 48 Base Fuze.....	33
Figure 5.	Instrumentation for Recording Gas Leakage.....	34
Figure 6.	Tracer Cavity and Plug Assembly Detail (BuOrd Drwg. No. 1246001).....	35
Figure 7.	Tracer Cavity Plug (BuOrd Drwg. No. 1246002).....	36
Figure 8.	Effects of Gas Erosion of a .040 hole in Mk 5 Tracer Body with and without an "O"-ring Seal.....	37
Figure 9.	8"/55 Premature with Mk 48 Fuze.....	38
Figure 10.	8"/55 Normal Field Test.....	39
Table 1.	Consolidation of Large Caliber Prematures from September 1950 to April 1952.....	17
Table 2.	Functioning Tests, Laboratory Firing Data, Mk 48 Base Fuze, Group I.....	18
Table 3.	Measurements of Leakage Pressures, Laboratory Firing Data, Mk 48 Base Fuze, Group II.....	19
Table 4.	Evaluation of "O"-ring Seals, Functioning Tests, Laboratory Firing Data, Mk 48 Base Fuze Group III.....	20
Table 5.	Evaluation of "O"-ring Seals, Measurement of Leakage, Laboratory Firing Data, Mk 48 Base Fuze, Group IV.....	21

CONFIDENTIAL
NAVORD Report 2830

	ILLUSTRATIONS	Page
Table 6.	Mk 48 Field Firing Data Group I.....	22
Table 7.	Mk 28 Field Firing Data Group I.....	23
Table 8.	Mk 28 Field Firing Data Group II.....	24
Table 9.	Mk 28 Field Firing Data Group III.....	25
Table 10.	Mk 28 Field Firing Data Group IV.....	26
Table 11.	Mk 48 Field Firing Data Group II.....	27
Table 12.	Mk 48 Field Firing Data Group III.....	28
Table 13.	Mk 48 Field Firing Data Group IV.....	29

CONFIDENTIAL
NAVORD Report 2830

ACKNOWLEDGEMENTS

The preparation of this report entailed the services and cooperation of several individuals and facilities of the Naval Ordnance Laboratory and the Naval Proving Ground, Dahlgren, Virginia. Acknowledgements are extended to Mr. S. Globe who directed and coordinated this investigation; to Mr. J. A. Templeton for the design work on the "O" ring application and his valuable advice in the early phases of the investigation; to Mr. A. A. Burgess for providing the electrical system of recording leakage pulses; to Mr. E. J. Micevich and Mr. D. D. Taylor of the Technical Evaluation Department in conducting the leakage tests in their dynamic pressure pulse generator; to Mr. R. Cromwell of the Terminal Ballistics Section, NPG, Dahlgren, Virginia for meticulously conducting the field firing program; and to the others who have contributed valuable time and skills in solving and correcting the problem of prematures.

CONFIDENTIAL
NAVORD Report 2830

INVESTIGATION OF PREMATURES EXPERIENCED IN
MAJOR CALIBER PROJECTILES

I. INTRODUCTION

1. During the period of June 1950 to June 1952, seventeen high order premature bursts occurred in the firing of 8"/55 and 16"/50 caliber guns in Naval service. Six of the 23,770 rounds of 8" HC fired in this period prematured (0.025%). Ten of the 3,447 rounds of 16" HC fired resulted in prematures (0.289%). As seen in the consolidation of prematures reported (Table 1), there is a correlation between the presence of a Mk 48 Base Detonating Fuze and the occurrences of high order prematures within limited distances from the gun. On 2 November 1951, a 16" AP projectile with a Mk 21 Mod 2 Base Fuze and a steel nose cap prematured on the USS New Jersey. The Mk 21 Mod 2 Base Fuze and the Mk 48 are identical except that the Mk 21 Mod 2 Base Fuze has longer delay (.033 millisecond), ball locks that prevent rebounding of the detonator plunger on armor penetration, and longer length of threads on the fuze body. On 5 September 1952, a 5"/38 caliber AA common with a Mechanical Time Fuze Mk 50 Mod 3, a Base Fuze Mk 28 Mod 15 with a Mk 9 Tracer, and an Auxiliary Detonating Fuze Mk 54 prematured on the USS Diamondhead (AE-19) at a close range. Until this time the investigation of prematures had been concentrated on the Mk 48 Base Fuze, and the Bureau of Ordnance requested that further explorations of the prematures include the Mk 28 Base Fuze. Basically, the Mk 28 and Mk 48 are alike and function similarly. The Mk 28 has stiffer detent and anti-creep springs and does not have the .010 millisecond delay present in the Mk 48. The term Mk 48 Base Fuze as used in this report applies to the Mods 0, 1, and 2 which are identical insofar as the pertinent dimensions and design features are concerned. For similar reasons the Mk 28 Mods 1 through 17 are referred to simply as the Mk 28 Base Fuze.

A. OPERATION OF MK 48 BASE FUZE

2. The Mk 48 Base Detonating Fuze (Figure 1) consists of a fuze body and nose cap. The body contains a detonator plunger assembly, an auxiliary plunger, a retaining plug, anti-creep spring assembly, detents, and side wall boosters. The nose cap houses the sensitive firing pin and detents. Arming occurs when the centrifugal forces on the detents exceed the side frictional forces due to setback. As the round leaves the muzzle, the setback force ceases and the centrifugal force on the detents snaps the detents outward. The detonator plunger

CONFIDENTIAL

CONFIDENTIAL
NAVORD Report 2830

is then unlocked but restrained rearward by the anti-creep spring. On impact the detonator plunger, aided by the momentum of the auxiliary plunger on its ball bearing, strikes the sensitive firing pin. The sensitive primer detonates, driving the delay element primer firing pin into the delay element primer, and also expands part of the inner cup of the anti-creep spring assembly into the holes drilled in the nose cap. This bulging of the inner cup locks the detonator in the forward firing position. The delay element primer ignites the .010 second black powder delay, which then actuates the detonator, lead outs, boosters and bursting charge.

B. PRELIMINARY STUDIES

3. In 1947, NOL reported sufficient setback energy in the firing pin of the Mk 54 and Mk 55 Auxiliary Detonating Fuzes to fire the detonator if the fuzes were assembled in an armed position (reference (a)). However, this does not explain the prematures since the fuze would function during setback and result in bore prematures. The nose fuze arming systems are not fully suspected as the cause since six of the premature rounds had steel nose plugs, and one of these, the 16"/50 AP Projectile, had no auxiliary detonating fuze.

4. A study of the circumstances surrounding the prematures (reference (b) through (f)) indicates that the Mk 48 Base Fuze action was the most reasonable initiator of the prematures reported. The frequency of prematures, the fact that all projectiles housed Mk 48 Base Fuzes, and the consistency in gun-to-burst distances eliminate probable causes of prematures that could occur in isolated cases. With this reasoning the investigation was immediately concentrated on the Mk 48 Base Fuze to determine all factors in malassembly or malfunctioning that could result in a premature exterior to the gun bore.

5. Assuming that the Mk 48 Base Fuze could initiate the prematures (an assumption that must be proved) the high order detonation of all prematures could be obtained only with normal firing of the detonator plunger with the lead-ins in line with the booster charges. "Cooking off" a component of the explosive train with the detonator plunger out of line would be expected to result in some low-order detonations or duds. In normal fuze functioning the sensitive primer is fired by the forward move-

CONFIDENTIAL
NAVCOR Report 2830

ment of the detonator plunger upon impact. This movement also aligns the lead-ins in the detonator plunger with the boosters.

6. The problem resolved itself into finding some action that would result in forward movement of the detonator plunger without impact. Creep forces, elastic vibrations due to shock in firing, and forces from the entry of propellant gas into the fuze are the predominant forces affecting plunger movement and will be covered in this report. The Naval Proving Ground, Dahlgren, Virginia reports that ten Mk 20 Fuzes fired in 4"/50 Mk 9 Mod 22 projectiles without anti-creep springs did not premature but fired on plate satisfactorily (reference (i)).

7. After numerous prematures in the fleet an investigation of major caliber ammunition was conducted which revealed the following:

a. USN Magazine, Port Chicago, California (reference (1)) - one projectile of fifty examined had no tracer sealing washer.

b. NAWD, Seal Beach, California (reference (d)) - 579 16"/50 HC Projectiles from U.S.S. Iowa, (1) 24 tracers - no luting on threads, (2) 34 rounds - broken tracer sealing washer, (3) 97 rounds - no tracer sealing washers. 270 16"/AP Projectiles from U.S.S. Iowa, (1) All threads - luting of very thin consistency, (2) 2 rounds - broken tracer sealing washers, (3) 2 rounds - no tracer sealing washers.

NAD, Crane, Indiana further reports excessive leakage past the tracer sealing washer and retaining plugs in approximately 10% of the 8" HC projectiles returned for inspection from the U.S.S. Des Moines (references (c) and (d)). Four of the prematures on the U.S.S. Missouri were definitely 16"/50 projectiles reworked at the Naval Ammunition Depot in Oahu (reference (f)). The other prematures on the U.S.S. Missouri were from undetermined lots but could have been reworked ammunition from Oahu. Examination of 16"/50 projectiles assembled in Oahu revealed that a considerable number of tracer sealing washers were malassembled or missing in the Mk 48 fuzes.

8. The foregoing mentioned defects shows that a relatively high proportion of base fuzes in large caliber ammunition fired during 1950 to 1952 were susceptible to propellant gas leakage. It is logical to expect a relationship between these defects and the prematures since leakage occurs in the base fuzes, which

CONFIDENTIAL
NAVED Report 2830

already have been shown to be the most plausible initiators of the prematures.

II. LABORATORY EXPLORATIONS - INVESTIGATIONS OF PREMATURES

A. BASIC PRESSURE TESTS

9. To determine the conditions that must exist in the Mk 48 Base Fuze for gas leakage to occur, fuzes were mounted in a test fixture in which the base of the fuze was exposed to controlled tank pressures of 10 to 1500 psi. Leakage was noted by expansion of a thin elastic membrane fitted over the nose of the fuze. By varying fuze components affecting the sealing qualities of the fuze the following results were obtained:

- a. Malassembled or missing lead washers invariably caused leakers.
- b. Rate of gas flow through the fuze increased as pressures on the fuze bases were increased.
- c. Leakage was greater when tracers were left unseated.
- d. Leakage was greatest when tracers and retainers were unseated.
- e. Absence of lutting increased gas leakage.

A program to study the effects of these conditions on fuze action was then conducted in a dynamic pressure pulse generator (Thundermug) in which bore pressures were simulated.

B. DESCRIPTION OF DYNAMIC PRESSURE PULSE GENERATOR (THUNDERMUG)

10. The Dynamic Pressure Pulse Generator (Thundermug), Figure 2, is a laboratory apparatus which subjects components to be tested to pressure-time characteristics similar to pressure pulses created in firing a gun. It consists of a cylindrical firing chamber closed at one end with a gasketed adapter in which a fuze may be mounted, and at the other by a heavy diaphragm. A black powder charge is fired in the chamber electrically, through leads in the cylinder wall. The pulse rise rate is controlled by the grain size of the black powder, the peak pressure jointly by the size of the charge and the thickness of the diaphragm which ruptures, and the pressure decay rate by the size of the aperture through which gases are expelled

CONFIDENTIAL
NAVORD Report 2830

when the diaphragm ruptures. A typical pressure-time pulse used in the Mk 48 tests is shown graphically in Figure 3-1.

C. STATIC FUNCTIONING TESTS

11. Twelve Mk 48 Fuzes were subjected to 8"/55 bore pressures in the Thunderbug to study the effects of shock and gas leakage tending to initiate prematures (Table 2). The conditions that affect propellant gas entry into the fuze, which were determined in the basic pressure tests, were varied in these static shots. The fuzes were assembled with steel plugs in the detent holes to allow normal movement of the detonator plunger when acted upon by any force. Scotch tape or aluminum foil was placed over the sensitive primer cap in each test. Fuze functioning was then determined by examining the tape for a perforation made by the plunger moving forward and striking the sensitive firing pin.

12. The tests conclusively show the following to exist:

- a. The Mk 48 Base Fuze can fire by propellant gas leakage into the fuze.
- b. The fuze will not fire solely by elastic vibrations due to shock in firing.

In test Nos. 6, 7, and 11 (Table 2) carbon deposits were found on the tracer cavity plug threads even though the fuzes did not premature. Gas leakage occurred past a normal lead washer seated properly in Test No. 11. This shows that gas leakage does not necessarily result in a premature and also that the sealing qualities of the lead washer alone are not satisfactory. A comparison of shots Nos. 11 and 12 indicates that the difference in friction, weights, and relative positions of fuze components due to tolerances also affect the malfunctioning of any one leaker. In test No. 3 the portion of the lead sealing washer exposed to a 3/5 diameter wrench hole in the base of the fuze melted and formed an enlarged hole (Figure 4). The erosion effect of the high temperature gases leaking into the fuze is clearly defined. The wrench hole in the fuze body is outlined by carbon residue on the tracer cavity plug. With extreme tolerances the conical tips of the wrench holes are .021 from the face on the fuze body on which the .025 lead sealing washer is seated. The .025 thick washer must be compressed .00+ to .021 to avoid direct exposure to gases.

CONFIDENTIAL
NAVORD Report 2830

D. MEASUREMENTS OF LEAKAGE PRESSURES

13. Pressure measurements in the auxiliary plunger chamber and in the tracer cavity were desired in order to analyze the action of the detonator plunger caused by gas leakage. This was required for two purposes: (1) to explain why the prematures in the fleet occurred at distances of 50 to 250 feet exterior to the gun bore, and (2) To fully evaluate the problem in order to provide the best solution.

E. DESCRIPTION OF INSTRUMENTATION FOR PRESSURE MEASUREMENTS

14. The Thundermug is instrumented to record the pressure pulse characteristics of its chamber pressures on a sweep synchronized 35 mm. film strip of approximately 160 milliseconds recording time in a six trace recording oscillograph. For comparison, it was desired to have the pressure characteristics of leakage into the fuze recorded on one trace of the film strip synchronized to the recorded bore pressures.

15. A tourmaline crystal was selected as the pressure sensitive device. This was mounted on a brass cap by attaching the crystal leads to a Kovar seal fixed in the cap. A nipple was screwed into the side of the fuze body and extended into the auxiliary plunger chamber of the fuze. The cap was then screwed down tightly on the end of the nipple exposed outside the fuze body. The crystal had a sensitivity of 4.84 ~~mc~~ coulombs per p.s.i. and a capacity of 8 ~~μ~~ farads.

16. A Keithley Phantom Repeater was used as an impedance matching device between the crystal and the CRO (Figure 5). The time constant of the input circuit was increased by shunting the repeater with a .005 ~~μ~~ farad capacitor.

17. Using the relationship $Q = CE$, the resulting sensitivity of the input circuit was calculated to be .968 millivolts per p.s.i. or approximately 1 millivolt per p.s.i. An audio oscillator was used to calibrate the leakage trace in the CRO in each test. A 1000 cps timing trace was provided by standard Thundermug instrumentation.

CONFIDENTIAL
NAVCOR Report 2830

F. CONCLUSIONS FROM PRESSURE MEASUREMENTS

18. Tests Nos. 13 through 18, Table 3, substantiate the data of the twelve functioning tests by showing that a pressure exists in the auxiliary plunger chamber whenever the fuze functions prematurely. This peak pressure may be as low as 15 to 20 p.s.i. and still result in a malfunction. In this series of shots the #025 lead sealing washer was folded in half and assembled in the fuze to simulate a damaged lead washer. Although this exposed bore gases to the inside face of the seating flange on the tracer cavity plug, no leakage was indicated past the retaining plug in test No. 13. Since no luting was used in assembly this shows that the tracer plug and retaining plug threads were responsible for the gas seal in this test and, therefore, may be expected to provide some sealing in a Mk 48 Base Fuze.

19. In test No. 15, the fuze fired with a 10 p.s.i. pressure peak in the auxiliary plunger chamber. The pressure-time characteristics of the leakage pulse are shown graphically in Figure 3-2. The firing time noted in the graph was measured by starting a Potter time when the firing circuit was closed and stopping it by shorting the timer on plunger impact with the sensitive firing pin. The fuze fired in this test before the Thundermug pulse (plotted in Figure 3-1 for comparison) had reduced to zero. In action firing the detents would prevent plunger movement until the projectile left the bore, thereby causing a continued leakage into the fuze similar to the dotted line P in Figure 3-2. This would result in a peak pressure of approximately 20 p.s.i. As seen in the graph, the pressure build-up is linear to point M and then flattens and diminishes. Because relatively high Thundermug pressures still exist, one can assume that the decreasing rate of build-up is due to an increasing volume as the plunger moves and that the plunger begins accelerating at point M or 79 milliseconds after closing the firing circuit. Since the sensitive primer fired 93 milliseconds after starting the test and there is a 10 millisecond explosive delay in the Mk 48 Fuze, this shot represents a premature occurring 24 milliseconds after the projectile leaves the bore or at a distance of 52.8 feet if an 8"/55 reduced charge was used. Actually, the peak pressures in the tracer cavity plug voids are higher than those in the auxiliary plunger chambers and gases will continue to flow into the plunger region for a short period after the projectile leaves the bore. This could cause prematures to occur at distances greater than 52.8 feet. Tests Nos. 19-26 were conducted to determine the pressures that any gas seal would have to withstand if the

CONFIDENTIAL
NAVORD Report 2830

tracer cavity plug threads leaked. In these tests the fuze bodies were cut off at the auxiliary plunger chamber and the piezoelectric crystal was mounted in an adapter in this chamber. #125 holes were drilled in the center of the retaining plugs to allow free gas flow to the crystal. Pressures recorded were thus pressures in the tracer cavity void. As seen in Table 3, the peak pressures of 50 and 100 psi in the tracer cavity voids were higher than those in the auxiliary plunger chambers of similar leakers. In test No. 21 a #040 hole was drilled through the side wall of the Mk 5 tracer. The pressure recorded in this instance was 1500 psi and rising when the crystal was destroyed by blast. This was considered to exceed the most extreme case of leakage into any fuze. Thus, any device used to prevent gas leakage must be effective when subjected to pressure of 50 to 100 psi and remain effective up to approximately 1500 psi.

III "O"-RING GAS SEAL TO PREVENT PREMATURES

A. DESCRIPTION OF THE "O"-RING MODIFICATION
IN PREVENTING GAS LEAKAGE

21. The method of sealing devised to prevent propellant gas leakage into the fuze incorporates a synthetic rubber "O"-ring (Z33-P-1560-300 NavOrd OSD 600) (AN 6227-15) placed around the tracer cavity plug at the nose end. Details of this assembly are shown in BuOrd drawing Nos. 1246001 and 1246002, Figures 6 and 7, respectively. The tracer cavity plug, Drawing No. 1246002, Figure 7, has been modified from the existing tracer plug not only by the presence of the shoulder for the "O"-ring, but also in the dimensioning of the length of the plug which assures seating of the plug on the plunger retainer under all conditions.

B. EVALUATION OF THE "O"-RING SEAL

22. The effectiveness of the "O"-ring modification was first tested by subjecting the seal to tank pressures of 1200 psi. The tracer plug was seated on the retaining plug and then backed off in #012 increments. The seal was effective at the seating position and remained so up to and including a #037 gap between the two pieces. With a #050 gap a momentary leak occurred and then sealed effectively. At #062 there was a continuous small

CONFIDENTIAL
NAVORD Report 2830

leak. Although no DC-4 lubricant was used in these tests, it was deemed necessary to positively seat the tracer plug on the retaining plug and avoid any possibility of gas pressure forcing the "O"-ring into a gap and so preventing it from sealing.

23. The "O"-ring seal, assembled in accordance with BuOrd Drawing No. 124-6001, Figure 6, was then test fired in the Dynamic Pressure Pulse Generator. Test Shot No. 23 shown in Table 3, subjected the "O"-ring seal to the extreme leakage limit discussed previously in which bore gases passed directly to the "O"-ring through a .040 hole in the side wall of the tracer body. No carbon deposits were visible in the fuze past the "O"-ring. Tests Nos. 25 and 26 substantiate the effectiveness of the "O"-ring. Leakage did not occur past the "O"-ring in Test No. 25. Shot No. 26 was similar to No. 23 except the auxiliary plunger chamber pressure was recorded. A leakage of 3 psi was noted; however, the slope of pressure build-up was approximately three times less than that shown of a premature in Figure 3-2. Examination of the fuze disclosed a slight bulge in the body at the "O"-ring seal. The 3 psi leak was attributed to a decrease in compression of the "O"-ring caused by the bulge. This test shows that the "O"-ring alone can prevent gas leakage up to pressures that actually can cause deformation of the fuze body.

24. In further evaluating the "O"-ring seal, three groups of "O"-rings were treated by exposure to extreme service conditions simulated in the laboratory and then test fired in fuzes suitably modified to induce prematures. The three groups consisted of (1) normal "O"-rings, (2) "O"-rings immersed in thread luting (35% raw linseed oil and 65% rosin by weight), and (3) "O"-rings immersed in purple lacquer. All groups were then temperature cycled for a minimum of one week at +150°C for 12 hours and then at -20°C for 12 hours. There was no apparent physical change in the "O"-ring resulting from this treatment.

25. In the first evaluation tests of the "O"-ring (Table 4, Tests 27-36) new "O"-rings and two from each condition treated group were assembled in fuzes suitably modified to induce prematures and fired in the Thundermug. The fuzes were assembled with steel plugs in the detent holes and loaded with token primers containing 35 mg of lead azide and plaster. No fuze fired even though some fuzes were modified by doubly exaggerating the conditions used to produce consistent prematures in previous Thundermug tests.

CONFIDENTIAL
NAVCOR Report 2830

26. To further evaluate the effectiveness of the "O"-ring seal, similar test shots, shown in Table 5, Nos. 37-42, were conducted and the pressures in the auxiliary plunger chamber were recorded. Two fuzes without "O"-rings were fired to again verify conditions for prematures. Both fuzes fired and pressure recordings showed a 70 and 100 psi pressure rise in the plunger chamber. In testing two new "O"-rings with the same fuze arrangements, no functioning occurred and pressure recordings showed no gas leakage. Two service conditioned "O"-rings were then fired in fuzes modified to expose the "O"-rings to direct bore pressures. The fuzes did not fire. In Test No. 41 a 10 psi pressure peak was noted; however, the slope of pressure build-up was three times less than the slope of pressure build-up of a premature. This test was a repetition of Test No. 26, in which the fuze body bulged due to direct entry of bore pressures. Again, the limiting pressure for an effective "O"-ring seal seems to be that at which the body will bulge. A comparison of the high pressure effects in a fuze with the "O"-ring modification to one without is shown in Figure 8, where the tracer bodies used in Test Shots Nos. 21, 23, 26, 41 and 42 are pictured. The bodies had .040 holes drilled in their side walls through which bore gases were admitted directly into the fuze. In Test No. 21 no "O"-ring was used and excessive gas erosion occurred at the .040 hole due to high gas leakage into the fuze. In Tests No. 23, 26, 41 and 42 the "O"-rings inserted in the fuzes prevented erosion by stopping the gas flow into the fuze. The "O"-rings in these tests were relatively unchanged by the effects of the high temperatures and high pressures of the gases.

IV. FIELD FIRING TESTS - INVESTIGATION OF PREMATURES

A. INTRODUCTION

27. The first group of field tests, Table 6, fired at the Naval Proving Ground, Dahlgren, Virginia, in an effort to duplicate the prematures reported in the fleet were 8 inch Mk 25 projectiles carrying smoke puff charges and Mk 48 base fuzes modified to induce gas leakage. Six test shots were fired through a target plate placed about 500 feet from the gun muzzle. The tests, however, were inconclusive. Physical observation by personnel and film strips of the tests failed to distinguish the smoke puffs expected from fuze action due to a premature or plate action. It was possible for the smoke puffs to occur near and be masked by the muzzle flash.

28. To assure a positive indication of prematures in subsequent field tests, the 8 inch Mk 25 projectiles were token loaded with approximately 1.5 pounds of explosive "D".

CONFIDENTIAL
NAVORD Report 2830

29. At this time the Bureau of Ordnance requested that this investigation include the Mk 28 Base Fuze used in 5" projectiles. In accordance with this request and in order to supplement and expedite the findings desired in the 8 inch field tests, a five inch field firing program was conducted using Mk 46 common projectiles fully loaded and fuzed with Mk 28 Base Fuzes. The 33 millisecond delays used in the Mk 21 fuze were placed in the explosive trains of all tests fuzes to doubly insure bore-clear action. Test shots in both the 5 inch and 8 inch firing programs were conducted by starting with a normal fuze and then gradually modifying each fuze in subsequent shots until premature conditions prevailed.

B. MK 28 BASE FUZE

30. In the first series of 5 inch firing tests, Table 7 Shot Nos. 1-12, the Mk 28 fuzes were assembled with doubled over lead tracer sealing washers simulating washers damaged in assembly of tracer plugs in fuzes. The plunger retaining plugs and the solid tracer cavity plugs were assembled in the fuzes with 25 and 30 ft. lbs. of torque respectively. Their threads were within normal production tolerances, and the retaining plugs were either slotted or drilled as shown in Figure 1. The rounds were fired without plate action at service and reduced velocities. The cork plug in the cartridge case was replaced with a pyralin disc in all shots after Test No. 6 in order to avoid carbon deposits affecting the various induced gas leakages. There were no prematures in this group of shots.

31. In the next group of Mk 28 field tests, Nos. 13-19, Table 8, the fuzes were further modified by combing the tracer plug threads and the retainer plug threads to minimum allowable tolerances and by assembling the pieces with 5 ft. lbs. of torque. Three consecutive prematures occurred in Rounds Nos. 13, 14 and 15 at approximately 100 feet from the muzzle. The plunger retainer plugs in these fuzes had a #040 hole drilled through their centers.

32. Two fuzes with #098 holes in the retainer plugs and two fuzes with #125 holes with fuze characteristics the same as noted above were then fired with the "O"-ring modification, Figures 6 and 7, in further substantiation of the effectiveness of the seal. No prematures occurred in these rounds.

33. An additional series of 5 inch tests, Group III, Table 9 Nos. 20-31 were conducted in which gas leakage past the retainer

CONFIDENTIAL
NAVCOR Report 2830

plug threads was more closely simulated. The #040 hole was drilled off center admitting gases in to the sides of the auxiliary plunger. In tests Nos. 22, 23 and 24 a #030 X #035 slot was milled longitudinally through the retainer plug threads. Further shots were fired with the outside diameter of the retainer plug threads reduced #010 to #020 less than the minimum allowable tolerance. The tracer plug threads were combed to minimum tolerances and the plugs were assembled with 2 to 20 ft. lbs. of torque. Fuze functioning was checked on target plate in tests Nos. 25 and 26 and found to be satisfactory. No prematures occurred in this group.

34. Two fuzes similar to the latter group were fired and recovered, Table 10, Nos. 32 and 33. Examination of the fuzes showed that a substantial gas leakage was present in these fuzes into the detonator plunger void, and can, therefore, be assumed to have occurred in the similar tests in Group III Table 9. This shows the gas leakage into the Mk 28 fuze does not necessarily result in a premature.

C. MK 48 BASE FUZE

35. The Mk 48 Base Fuze field firing program using eight inch Mk 25 HC projectiles token loaded with Explosive "D", Tables 11, 12, and 13 correspond to the Mk 28 program. The tests were conducted using fuzes in which gas leakage was increasingly induced in successive shots until conditions for prematures were reached.

36. A premature occurred 215 feet from the muzzle in test No. 15. Sequence photographs of the detonation action are shown in Figure 9. A normal eight inch test shot is pictured in Figure 10 for comparison. The fuze characteristics of this round were similar to the Mk 28 fuzes that prematured in the 5 inch tests. The retainer plug has a #040 hole drilled through its center; the tracer plug was assembled with 5 ft. lbs. of torque, and its threads were combed to the minimum allowable tolerances.

37. Four test shots, Nos. 20, 21, 22 and 23, were then fired for further evaluation of the "O"-ring seal. Two fuzes had #040 holes in the retainer plugs and two had #098 holes. The general fuze characteristics were the same as the premature round. No prematures occurred in these shots.

38. The two low order detonations and the two duds listed in Group III, Table 12, are attributed to low target impacts and

CONFIDENTIAL
NAVCOR Report 2830

possible grazing action on a portion of the sand butts behind the target. This could have caused the detonator plunger to rebound out of alignment before the .033 millisecond delay detonated the remainder of the explosive train.

39. In the last group of test shots, Group IV, Table 13, the gas leakage past the retainer plug was more closely controlled. The tests included shots with off center holes drilled in the retainers, longitudinal slots milled in the retainer threads, and ball check valves placed in the tracer and retainer plugs to regulate the time and quantity factors involved in a gas induced premature. However, no prematures were obtained in these tests.

D. SUMMARY OF FIELD FIRING DATA

40. Although many of the test shots in the field did not premature when gas leakage was induced there was sufficient resultant data to correlate and substantiate the tests made in the Dynamic Pressure Pulse Generator. The difficulty experienced in obtaining prematures in the field was expected and can be attributed to the complexity existing in the selection and control of the variables affecting gas flow into the fuze, the most pronounced of which are as follows:

a. The rate of gas flow into the tracer cavity, the pressure attained, and the exact volume of void between the tracer plug and the body of the fuze.

b. The rate of gas flow into the auxiliary plunger chamber and the final pressure attained.

c. The rate of gas flow past the anti-creep assembly into the space at the forward end of the plunger, the sealing qualities of the nose cap, and the final pressure attained which can be in equilibrium with the pressure at the rear and so prevent movement of the plunger.

d. Variations in clearance between the plunger and the fuze body due to tolerances.

e. Differences in frictional forces impeding movement of the plunger and variations in compression loads of the anti-creep springs.

f. The rate of gas flow rearward out of the fuze after the projectile leaves the gun bore.

CONFIDENTIAL
NAVCOR Report 2830

41. These variables indicate that a low probability exists for any particular leaker to result in a premature. Therefore, for any number of prematures caused by propellant gas leakage a far greater number of fuzes must be leakers. This is substantiated by analyses, referred to in Preliminary Studies, that were performed by NAD, Crane, Indiana of 8" HC ammunition from lots in which prematures occurred. Excessive gas leakage occurred in 10% of the rounds when subjected to 5,000 psi of hydrostatic pressures. This gives a very conservative measure of the percentage of leakers to be expected when fired at bore pressures. In comparisons the premature rate of 8" HC projectiles during the period June 1950 to June 1952 was 0.025%.

V. INVESTIGATION OF PREMATURES CAUSED BY SIDE ENTRY OF CASES

A. LABORATORY PRESSURE TESTS

42. The sealing quality of the booster cover and nose caps of the Mk 28 and Mk 48 Base Fuzes is poor when subjected to gases under pressure. Ammonia gases released from Explosive "D" and propellant gases can enter the sides of the fuze from the fuze cavity. The cavity pressures due to the evolution of ammonia gases reaches a steady state of less than one atmosphere. The maximum volume of void in the fuze cavity of a projectile (.457 cubic inches) closely approximates the total volume of void inside the Mk 28 and Mk 48 Fuzes (.441 cubic inches). If the entire volume of gases passed from the cavity void into the fuze, a peak pressure of 30 psi would not be exceeded. A study made at this Laboratory of propellant gas leakage past the copper-lead fuze gas checks into the fuze cavity indicates that the maximum pressures attained in the fuze cavity are less than 300 psi. In order to include these two pressures and a marginal factor, the test pressures used in this phase of the investigation were fixed at 0 to 1200 psi.

43. Tests were conducted in which conditions favorable to base fuze functioning by the side entry of gases were gradually exaggerated. In all of the tests the fuze was mounted nose down in a pressure chamber. Detents in the fuze were removed to permit firing. Cellulose tape was placed over the sensitive primer hole in the primer cover. Firing of the fuze would have been indicated by a perforation of the tape by the firing pin. Since movement of the plunger by gas pressure requires a pressure differential between the ends of the detonator plunger, and the differential could occur on either entry or release of gases in the fuze, both cases were covered in this investigation. Gas

CONFIDENTIAL
NAVORD Report 2830

pressure was provided in a reservoir connected to a nitrogen tank through a pressure regulating valve. The pressure was admitted around the fuze by a quick acting solenoid valve. This pressure was retained in the test chamber to allow steady state conditions to occur where pressure in the fuze equalled the chamber pressure. The release pulse was then accomplished by venting the test chamber through another quick release valve.

44. The tests were conducted at pressures varying between 10 and 1200 psi. At each pressure level the following fuzes were used:

- a. A normal fuze.
- b. A fuze with a #125 hole drilled through the booster cover and aligned with a plunger detent hole.
- c. A fuze with a #125 hole drilled through the nose cap lock pin hole, thereby exposing the outer housing of the anti-creep assembly to chamber pressures.
- d. A fuze with a #125 hole drilled in the sensitive primer=detent hole cover.
- e. A fuze with a #250 hole drilled in the sensitive primer detent hole cover.

In addition, all fuzes were tested at the various pressure levels with the anti-creep assemblies removed and mounted in the pressure reservoir horizontally. No fuze functioned in any of the tests.

VI. CONCLUSIONS

45. The Laboratory finds that:

- a. Prematures similar in nature to those reported with major caliber ammunition since 1950 can be caused by propellant gas leakage past the tracer cavity plugs and into the Mk 28 and Mk 48 Base Fuzes on firing.
- b. Prematures of this type should not occur if sufficient sealing is provided.
- c. The shock of firing alone is not sufficient to fire the fuze.
- d. Side entry of gases from the fuze cavity into the nose end of the fuze will not result in a premature.

CONFIDENTIAL
NAVORD Report 2830

46. The Laboratory recommends that the "O"-ring gas seal, Figures 6 and 7, BuOrd Dwg. Nos. 1246001 and 1246002 respectively, be utilized as the best way to effectively eliminate gas leakage in the present designs of the Mk 28 and Mk 48 Base Fuzes.

CONSOLIDATION OF LARGE CALIBER REMATURES FROM SEPTEMBER 1950 TO APRIL 1952

CONFIDENTIAL
NAVCARD Report 2830

DATE	VESSEL	PROJECTILE	VELOCITY	BASE FUZE	NOSE FUZE	AUX. DET. FUZE	DISTANCE TO FIRST
9/16/50	USS Missouri	16"/50 HC	Reduced	Mk 48-0	Mk 29-3	Mk 55-0	50 ft.
10/12/50	USS Missouri	16"/50 HC	Service	Unknown	Mk 29-3	Unknown	300 to 600 ft.
2/22/51	USS Missouri	16"/50 HC	Reduced	Mk 48-0	Mk 29-3	Mk 55-0	225 ft.
3/14/51	USS Missouri	16"/50 HC	Reduced	Mk 48-0	Steel Plug	Mk 55-0	600 ft.
3/14/51	USS Missouri	16"/50 HC	Reduced	Mk 48-0	Mk 29-3	Mk 55-0	600 ft.
3/14/51	USS Missouri	16"/50 HC	Reduced	Unknown	Steel Plug	Unknown	600 ft.
3/18/51	USS Missouri	16"/50 HC	Reduced	Mk 48-0	Steel Plug	Mk 55-0	225 ft.
7/11/51	USS New Jersey	16"/50 HC	Service	Mk 48-0	Mk 29-3	Mk 55-0	40 to 100 ft.
10/2/51	USS New Jersey	16"/50 HC	Service	Mk 48-1	Steel Plug	Mk 55-0	100 to 150 ft.
10/2/51	USS New Jersey	16"/50 HC	Service	Mk 48-0	Steel Plug	Mk 55-0	100 to 150 ft.
11/2/51	USS New Jersey	16"/50 AP	Reduced	Mk 21-2	-----	-----	125 ft.
7/ /50	USS Des Moines	8"/55 EC	Reduced	Mk 48-1	Mk 29-3	Mk 54-1	250 ft.
7/ /50	USS Des Moines	8"/55 HC	Reduced	Mk 48-1	Mk 29-3	Mk 54-1	250 ft.
6/16/51	USS Des Moines	8"/55 HC	Reduced	Mk 48-1	Steel Plug	Mk 54-1	60 ft.
6/21/51	USS Des Moines	8"/55 HC	Reduced	Mk 48-1	Mk 29-3	Mk 54-1	60 ft.
12/12/51	USS Des Moines	8"/55 HC	Service	Mk 48-0	Mk 29-3	Mk 54-1	60 ft.
4/1/52	USS Des Moines	8"/55 HC	Not reported	Mk 48-1	Mk 29-3	Mk 55-0	125 ft.

NOTE: (1) Subsequent investigations on the USS Missouri have disclosed that the premature distances of 600 ft. were probably overestimated. Examination of the photograph of the premature in a 9 gun salvo on 14 March 1951 shows the premature detonating approximately 150 ft. from the battery.

Table 1

LABORATORY FIRING DATA - MK 48 BASE FUZE
IN DYNAMIC PRESSURE PULSE GENERATOR
GROUP I
FUNCTIONING TESTS

CONFIDENTIAL
NAVED Report 2830

Shot No.	Retainer	Tracer	Normal Chamber		Fired	Remarks
			Lead Washer	Pressure psi		
1	#040 hole	Mk 5 - Normal	None	40,000	Yes	Extreme tolerances on parts
2	#040 hole	Brazed to body	None	42,000	No	See Note (1)
3	#040 hole	Mk 5 - Normal	Yes	41,000	Yes	Lead washer burned through
4	#040 hole	Brazed to body	None	42,500	No	See Note (1)
5	#040 hole	Brazed to body	None	45,300	No	See Note (1)
6	Normal	Tight to body	None	No record	No	Carbon deposits in tracer cavity
7	Normal	Tight to body	Yes	38,800	No	Gas residue on tracer threads
8	1/4 turn off	Tight to body	Yes	47,500	No	Tracer not seated on retainer
9	1/4 turn off	Mk 5 - 1/2 off	None	51,500	Yes	Tracer not seated on retainer
10	1/4 turn off	Shipping plug 1/4 off	None	49,000	Yes	Fired hard. Carbon visible at plunger.
11	1/4 turn off	Solid - Normal	Yes	51,300	No	See Note (2)
12	1/4 turn off	Solid - Normal	Yes	44,200	Yes	See Note (2)

NOTES: (1) Three (3) separate fuzes tested with conditions controlled to prevent gas leakage.
 (2) Two (2) separate fuzes tested with similar assembly conditions.
 (3) All fuzes fired with steel plugs in detent holes. Firing indicators - (a) Nos. 1-9. Scotch tape over sensitive primer cap on detonator plunger, (b) Nos. 10-12. Aluminum foil. No luting used in assembly of fuzes.
 (4) Threads on retaining plug and tracer - 20 NS. 1/4 turn off represents #0125 clearance in lieu of metal-to-metal seating.
 (5) Carbon deposits in tracer cavity void in Shots Nos. 1, 6, 7, 11 and 12. Carbon deposits at detonator plunger in Shots Nos. 3 and 10.

Table 2

LABORATORY FIRING DATA - MK 48 BASE FUZE
 IN DYNAMIC PRESSURE PULSE GENERATOR
 GROUP II
 MEASUREMENTS OF LEAKAGE PRESSURES

CONFIDENTIAL NAVCAM Report 2830

Shot No.	Retainer	Tracer	Chamber		Leakage psi	"O" Ring	Fired	Remarks
			Pressure psi	Failure				
13	1/4 turn off	Solid	49,980	None	None	None	No	
14	1/2 turn off	Solid	44,625	70	None	None	Yes	
15	1/4 turn off	Solid	48,000	10	None	None	Yes	
16	TEST	UNSUCCESSFUL				MECHANICAL FAILURE DESTROYED FUZE		
17	1/4 turn off	Solid	No record	None	None	None	No	Reduced charge
18	1/4 turn off	Solid	No record	None	None	None	No	
19	#125 hole	Mk 5	26,250	None	None	None	--	See Note (1)
20	#125 hole	Mk 5	51,000	--	None	None	--	** Short pressure pulse
21	#125 hole	Mk 5w/ #040 hole	47,100	Over 1500	None	None	--	** Crystal destroyed by blast
22	#125 hole	Mk 5	34,900	100	None	None	--	See Note (1)
23	#125 hole	Mk 5w/ #040 hole	44,600	--	Yes	Yes	--	** No visible leakage past "O"-ring
24	--	Mk 5	24,800	50	None	None	--	** No retainer used
25	#125 hole	Mk 5	46,125	None	Yes	Yes	--	See Note (1)
26	Normal	Mk 5w/ #040 hole	44,250	3	Yes	Yes	--	** Body of fuze bulged behind "O"-ring

** See Note (1)

NOTE: (1) Bodies of fuze Nos. 19-26 cut off at auxiliary plunger chamber. Crystal mounted in an adapter in auxiliary plunger chamber. Leakage not measured in Fuzes Nos. 17, 20 and 23.
 (2) Threads on retaining plug and tracer - 20 NS. 1/4 turn off represents #0125 clearance in lieu of metal-to-metal seating. Leakage listed is peak pressure in auxiliary plunger chamber. No luting used in assembly.
 (3) Firing indicator for shots 13-18 - aluminum foil.
 (4) Lead washer used was #025 thick folded in half. Used in all tests except Nos. 17 and 18 in which washer was omitted.

Table 3

LABORATORY FIRING DATA - MK 48 ASE FUZE
 IN DYNAMIC PRESSURE PULSE GENERATOR
 GROUP III
 EVALUATION OF "O"-RING SEALS

Test No.	Retainer	Tracer	Washer	Folded Chamber Pressure psi	"O"-Ring	Fired
27	1/4 turn off	Mk 5-1/4 turn off	No	47,600	New - Untreated	No
28	1/4 turn off	Mk 5-1/2 turn off	No	45,700	New - Untreated	No
29	Tight	Solid 1/2 turn off	Yes	39,700	New - Untreated	No
30	1/2 turn off	Solid 1/2 turn off	Yes	45,700	New - Untreated	No
31	1/4 turn off	Solid 1/4 turn off	Yes	44,250	S.T. - Untreated	No
32	1/2 turn off	Solid 1/2 turn off	Yes	49,125	S.T. - Untreated	No
33	1/4 turn off	Solid 1/4 turn off	Yes	39,600	S.T. - Lacquer Treated	No
34	1/2 turn off	Solid 1/2 turn off	Yes	43,800	S.T. - Lacquer Treated	No
35	1/4 turn off	Solid 1/4 turn off	Yes	46,000	S.T. - Luting Treated	No
36	1/2 turn off	Solid 1/2 turn off	Yes	47,600	S.T. - Luting Treated	No

NOTES: (1) Fuzes fired with steel plugs in detent holes. Firing indicators - token primers with 35 mg. of lead azide and plaster.
 (2) No measurements of gas leakage made.
 (3) Surveillance tested (S.T.) "O"-rings subjected to -60°F temperature for 12 hours, then to 160°F at a high humidity for 12 hours continuously repeated for 1 week. "O"-rings as noted dipped in purple lacquer or luting and then exposed to temperature and humidity tests.
 (4) Threads on retaining plug and tracer - 20/31/4 turn off represents #0125 clearance in lieu of metal-to-metal seating. No luting used in fuze assembly.

Table 4

LABORATORY FIRING DATA - MK 48 BASE FUZE
IN DYNAMIC PRESSURE PULSE GENERATOR
GROUP IV
EVALUATION OF "O"-RING SEALS - MEASUREMENT OF LEAKAGE

Test No.	Retainer	Tracer	Chamber Pressure psi	Leakage	"O"-Ring	Fired
37	1/8" hole	Solid - Flush with base	47,600	70 psi	None	Yes
38	1/8" hole	Solid - Flush with base	44,250	100 psi	None	Yes
39	1/8" hole	Solid - 1/2 turn off	47,625	None	New	No
40	1/8" hole	Solid - 1/2 turn off	45,750	None	New	No
41	1/8" hole	Hollow - ".040 hole	47,750	10 psi	S.T.-Untreated	No
42	1/8" hole	Hollow - ".040 hole	45,000	None	S.T.-lacquer Treated	No

NOTES: (1) Fuzes fired with steel plugs in detent holes. Crystal mounted in side of fuze body above the retaining plug. Folded over lead sealing washers in all shots. Firing indicators - token primers with 35 mg. lead azide and plaster.

(2) Surveillance tested (S.T.) "O"-rings subjected to -60°F temperature for 12 hours, then to 160°F at a high humidity for 12 hours continuously repeated for 1 week. "O"-rings as noted dipped in purple lacquer or luting and then exposed to temperature and humidity tests.

(3) Threads on tracer - 20 NS. 1/2 turn off represents .025 clearance between flange on tracer, lead sealing washer, and seating face on fuze body.

(4) Slope of pressure build-up of leakage in No. 41 three times less than Shot Nos. 37 and 38.

MK 48 FIELD FIRING DATA
GROUP I

Test No.	Retainer Size of Drill (B)	Velocity	Target	Premature	Remarks
1	"040	1800 fps	3/4" STS	No	Possible plate action
2	"040	1800 fps	3/4" STS	No	Fuze action indeterminate
3	"040	1800 fps	3/4" STS	No	Fuze action indeterminate
4	"125	2800 fps	1" STS	No	Fuze action indeterminate
5	"125	2800 fps	1" STS	No	Possible plate action
6	"125	2800 fps	1" STS	No	Fuze action indeterminate

NOTES: (1) All fuzes assembled in Mk 25 HC projectiles, smoke-puff loaded with black powder, and fired in an 8"/55 gun.
 (2) Doubled over lead tracer sealing washers assembled in all fuzes. Threads on the retaining plug and tracer cavity plug with normal production tolerances. No luting applied. Both plugs seated with 30 ft. lbs. torque.
 (3) Smoke puff was not distinguishable from gun and plate flashes. Evaluation of camera shots was indeterminate.

Table 6

MK 28 FIELD FIRING DATA
 GROUP I

Test No.	Depth of Slots (A)	Retainer Size of Luting		Premature	Remarks
		Drill Center (B)	Threads on		
1	-----	-----	Yes	Reduced	Water impact at 8,000 yds.
2	-----	-----	No	Reduced	Water impact at 8,000 yds.
3	-----	-----	No	Reduced	Water impact at 8,000 yds.
4	-----	-----	No	Reduced	Water impact at 8,000 yds.
5	0015	-----	Yes	Reduced	Water impact at 8,000 yds.
6	0015	-----	No	Reduced	Water impact at 8,000 yds.
7	0018	-----	No	Service	Water impact at 12,000 yds.
8	0018	-----	No	Reduced	Water impact at 8,000 yds.
9	0025	-----	No	Service	Water impact at 12,000 yds.
10	0025	-----	No	Reduced	Water impact at 8,000 yds.
11	-----	0028	No	Service	Water impact at 12,000 yds.
12	-----	0040	No	Reduced	Water impact at 8,000 yds.

NOTES: (1) Fuzes fired in 5" M1 46 commonly loaded projectiles in 5"/38 gun. Rounds fired at 8,000 - 12,000 yds. without plate action. Bore pressures (a) Reduced velocity - 17,400 psi (b) Service Velocity - 46,500 psi.
 (2) All fuzes assembled with doubled over lead tracer sealing washers. Retainer and cavity plug threads with production tolerances. Seating torque on retainer plug - 25 ft lbs. Seating torque on the tracer cavity plugs - 30 ft. lbs.

Table 7

MK 28 FIELD FIRING DATA
 GROUP II

Rest No.	Retainer Size of Drill(Center)	"O"-Ring Solution	Velocity	Premature	Remarks
13	":040	No	Service	Yes	H.O. 125 ft. from gun
14	":040	No	Service	Yes	H.O. 100 ft. from gun
15	":040	No	Service	Yes	H.O. 100 ft. from gun
16	":098	Yes	Service	No	Water impact at 12,000 yds.
17	":098	Yes	Service	No	Water impact at 12,000 yds.
18	":125	Yes	Service	No	Water impact at 12,000 yds.
19	":125	Yes	Service	No	Water impact at 12,000 yds.

NOTES: (1) Fuzes fired in 5" Mk 46 common fully loaded projectiles at 12,000 yds. without plate action. Bore pressure - 46,500 psi.
 (2) All fuzes assembled with doubled over lead tracer sealing washers. Retaining plug and tracer cavity plug threads combed to minimum tolerances. Seating torque on retaining plug and tracer cavity plug - 5 ft. lbs. No luting on threads.

Table 8

MK 28 FIELD FIRING DATA
GROUP III

Test No.	Depth of Slots (A)	Size of Drill (B)	Retainer		Threads Min. Tol.	Seating Torque ft. lbs.	Tracer Plug Seating Torque	Premature	Remarks
			Threads	Min. Tol.					
20	----	040	No	No	10	5	No	Water impact at 12,000 yds.	
21	----	040	Yes	Yes	5	5	No	Water impact at 12,000 yds.	
22	020	030 X	No	No	10	20	No	Water impact at 12,000 yds.	
23	020	035 slots thru threads	No	No	5	5	No	Water impact at 8,000 yds.	
24	025		No	No	5	5	No	Water impact at 12,000 yds.	
25	020	----	Yes	Yes	5	5	No	3/4" plate. HO behind plate	
26	020	----	Yes	Yes	2	2	No	3/4" plate. HO behind plate	
27	025	----	&-005		2	5	No	Water impact at 12,000 yds.	
28	025	----	&-010		2	5	No	Water impact at 12,000 yds.	
29	020	----	&-015		2	5	No	Water impact at 8,000 yds.	
30	020	----	&-020		2	2	No	Water impact at 12,000 yds.	
31	----	----	&-010		1/4 turn off	2	No	Water impact at 12,000 yds.	

NOTES: (1) Fuzes fired in 5" Mk 46 common fully loaded projectiles in 5"/38 gun. Rounds fired at 8,000 - 12,000 yds. without plate action, except Nos. 25 and 26. Bore pressure (a) Reduced Velocities - 17,400 psi, (b) Service Velocities - 46,500 psi.

(2) All fuzes assembled with doubled over lead tracer sealing washers. Threads on tracer cavity plug combed to minimum tolerances. 040 holes in retaining plug drilled off center. No luting on retainer or tracer plug threads.

Table 9

MK 28 FIELD FIRING DATA
GROUP IV
FIRED AND RECOVERED

Test No.	Retainer	Target	Remarks
32	.040 hole off center	1" STS	Pronounced gas leakage through to the detonator plunger. Flow path through .040 hole, evidence of gas jet on rear of auxiliary plunger, strong flow through the four ball grooves of auxiliary plunger. Gas residues also on inside the booster cover at the detent holes in the fuze body. Fuze functioned.
33	.035 x .030 slots in threads .025-depth of slots in seating face	1/4" STS	Pronounced gas leakage to the detonator plunger. Flow path through .035 x .030 longitudinal slots in retainer threads and through ball grooves in the auxiliary plunger. Fuze functioned.

NOTES: (1) Fuzes fired in 5" Mk 46 common inert projectiles in 5"/38 gun. Target 200 ft. from gun. Rounds fired at service velocity - 46,500 psi bore pressure. Rounds retrieved from sand butts.

(2) Both fuzes assembled with doubled over lead sealing washers, no luting, minimum tolerances on threads and with the tracer cavity plugs and retaining plugs seated with 5 ft. lbs. of torque.

Table 10

MK 48 FIELD FIRING DATA
GROUP II

Test No.	Retainer		Tracer		Velocity	Prema- ture	Remarks
	Depth of Slots (A)	Luting on Threads	Cavity Plug Threads Seating	Min. Tol. Torque ft. lbs.			
7	None	Yes	No	30	Reduced	No	H0 70' behind plate
8	None	No	No	30	Reduced	No	H0 70' behind plate
9	None	No	Yes	5	Reduced	No	H0 70' behind plate
10	#018	No	Yes	5	Reduced	No	H0 70' behind plate
11	#025	No	Yes	5	Service	No	H0 70' behind plate
12	#025	No	Yes	2	Service	No	H0 70' behind plate

NOTES: (1) Fuzes fired in 8" Mk 25 H. C. projectiles token loaded with 1.3 lbs. of explosive "D" in an 8"/55 gun. Rounds fired at 3/4" STS plate 500 ft. from gun. Bore pressures - (a) Reduced velocity (2200 fps) - 39,300 psi pressure, (b) Service velocity (2600 fps) - 42,200 psi pressure.
(2) All fuzes assembled with doubled over lead tracer sealing washers. Retainer plugs with production tolerances on threads and seated with 30 ft. lbs. torque.

Table 11

MK 48 FIELD FIRING DATA
GROUP III

CONFIDENTIAL
NAVGROD Report 2830

Test No.	Retainer Size of Drill(B)	Tracer Cavity Plug Threads Min.Tol.	Seating Torque ft.lbs.	Ring Solution	Velocity	Premature	Remarks
13	:.028	Yes	5	-----	Reduced	No	HO 70° behind plate
14	:.028	Yes	5	-----	Reduced	No	HO 70° behind plate
15	:.040	Yes	5	-----	Service	Yes	HO premature 215' from gun
16	:.040	Yes	5	-----	Service	No	HO 100° behind plate
17	:.040	Yes	30	-----	Service	No	LO 700° behind plate
18	:.040	No	5	-----	Service	No	Dud (no plate action)
19	:.040	No	30	-----	Service	No	HO 70° behind plate
20	:.040	Yes	5	Yes	Service	No	HO 70° behind plate
21	:.040	Yes	5	Yes	Service	No	LO 70° behind plate
22	:.125	Yes	5	Yes	Service	No	HO 70° behind plate
23	:.125	Yes	5	Yes	Service	No	Dud (no plate action)

NOTES: (1) Fuzes fired in 8" Mk 25 HC projectiles token loaded with 1.3 lbs. of explosives "D" in an 8"/55 gun. Rounds fired at 3/4" STS plate 500 ft. from gun. Bore pressures - (a) Reduced velocity (2200 fps) - 39,300 psi, (b) Service velocity (2600 fps) - 42,200 psi.
(2) All fuzes assembled with doubled over lead tracer sealing washers. Retaining plugs seated with 5 ft. lbs. torque, threads combed to minimum tolerances. Luting omitted on threads.

Table 12

MK 48 FIELD FIRING DATA
GROUP IV

Test No.	Retainer Modification	Retainer Threads Min. tol.	Retainer Seating Torque ft. lbs.	Tracer Plug Ball Check Valve	Velocity	Preme-ture
24	"040 drill	---	30	Yes	Service	NC
25	"055 drill	---	30	Yes	Service	NC
26	"075 drill	---	30	Yes	Reduced	NC
27	"040 drill	---	30	---	Reduced	NC
28	"055 drill	---	30	---	Service	NC
29	"040 drill	---	30	---	Service	NC
30	"020 slots	"030 by ("035 slots (in threads	30	---	Service	NC
31	"020 slots	Yes	Off 1/2 turn	---	Service	NO
32	"020 slots	& - "020	Off 1/2 turn	---	Reduced	NO

CONFIDENTIAL
NAVORD Report 2830

REMARKS: Water impacts of all test rounds noted at 10,000 to 16,000 yds.

NOTES: (1) Fuzes 24-29 further modified with off center Ball Check Valves in retainer.
 (2) Fuzes fired in 8" Mk 25 HC projectiles token loaded with 1.3 lbs. of explosive "P" in an 8"/55 gun. Bore pressures - (a) Reduced velocity (2200 fps) - 39,300 psi, (b) Service velocity (2600 f s) 42,200 psi.
 (3) All fuzes assembled with doubled over lead tracer sealing washers. Tracer cavity plugs seated with 5 ft. lbs. torque, threads combed to minimum tolerances. Ball check valve (BCV) in retainer - closed during setback - open after setback. Ball check valve in tracer cavity plug - open during setback - closed after setback.

Table 13

CONFIDENTIAL
NAVORD REPORT 2830

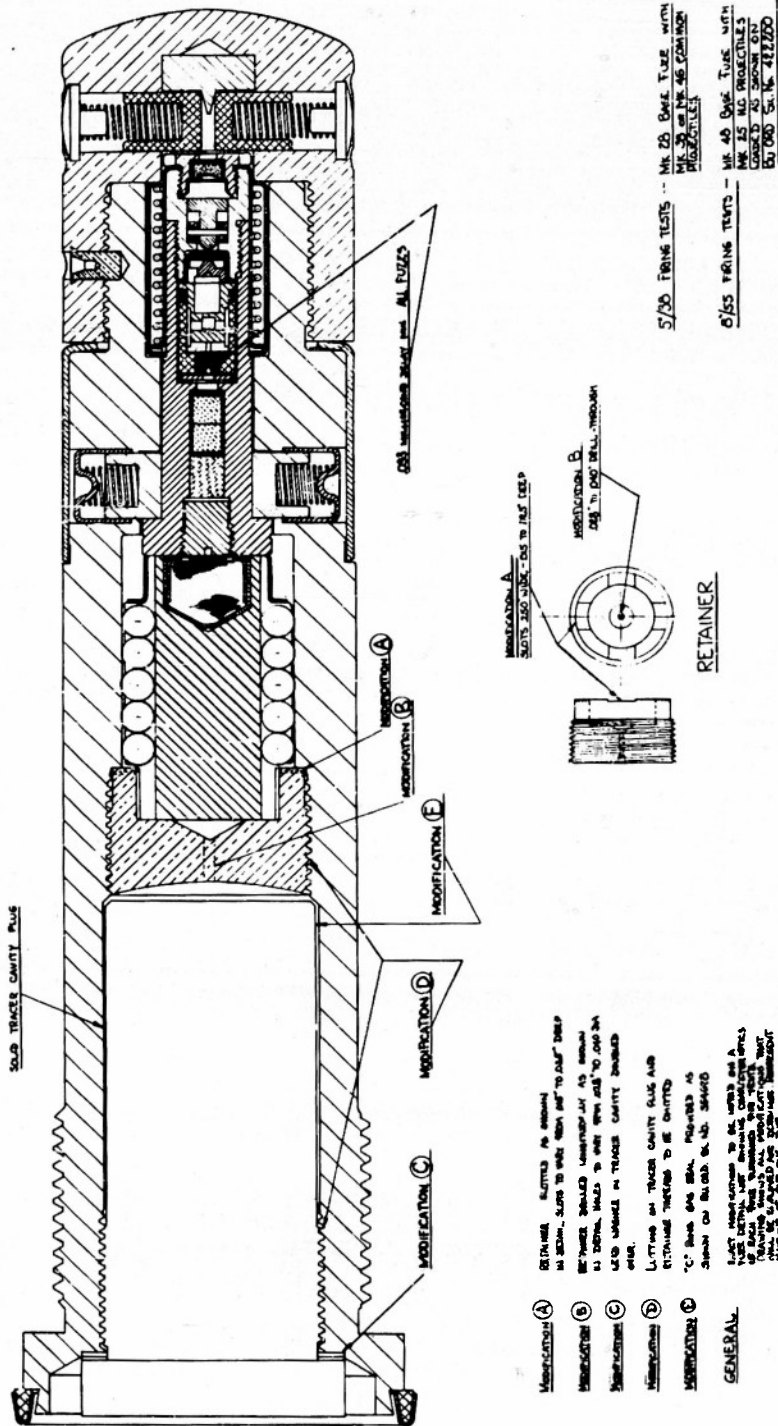

FIG. 1 GENERAL ARRANGEMENT OF MK 48 BASE FUZE
SHOWING MODIFICATIONS TO INDUCE PREMATURES

CONFIDENTIAL

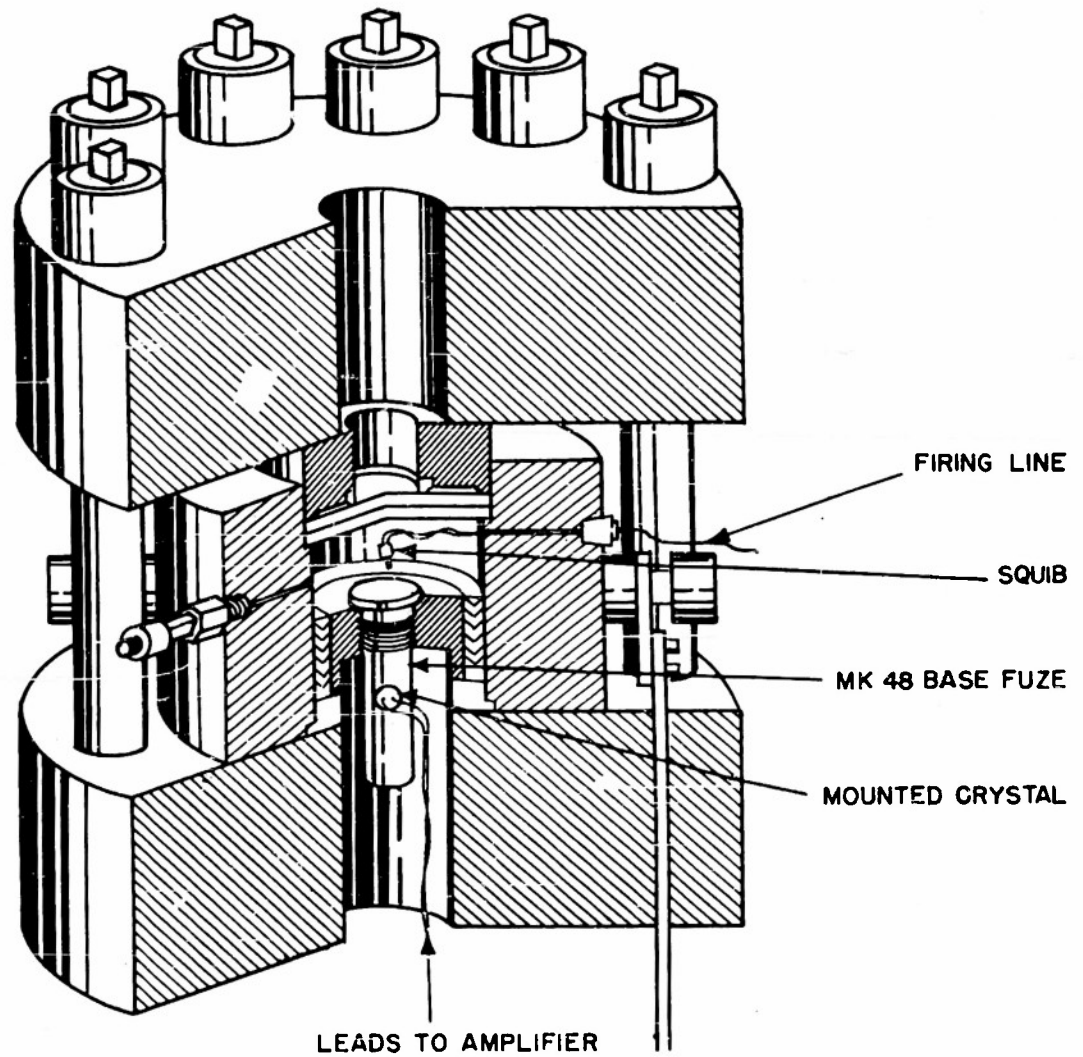

FIG. 2 DYNAMIC PRESSURE PULSE GENERATOR
(THUNDERMUG)

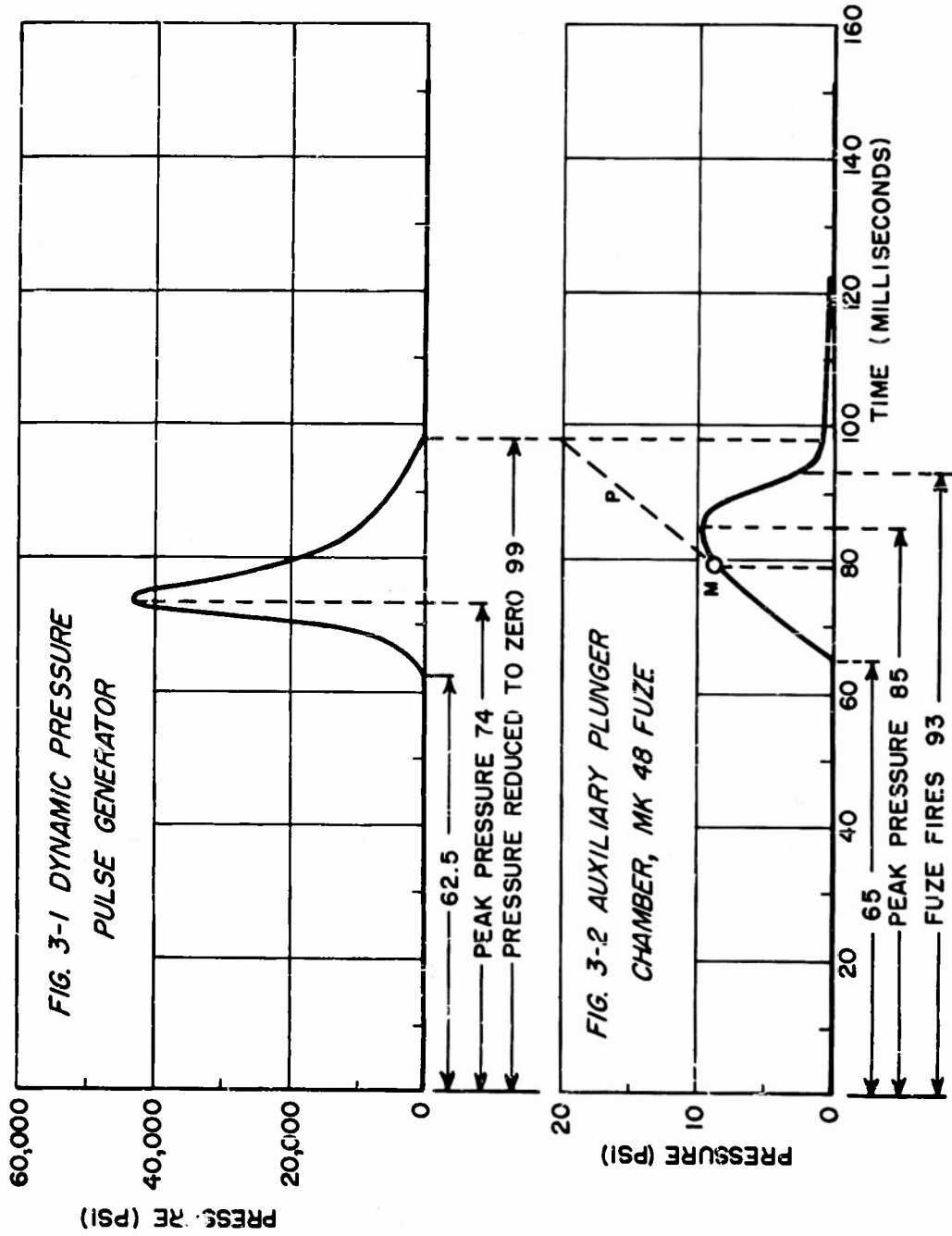

FIG. 3
PRESSURE PULSE CHARACTERISTICS

CONFIDENTIAL
NAVORD REPORT 2830



FIG. 4 EFFECTS OF GAS EROSION ON
A NORMAL LEAD WASHER ASSEMBLED
IN A MK 48 BASE FUZE
CONFIDENTIAL

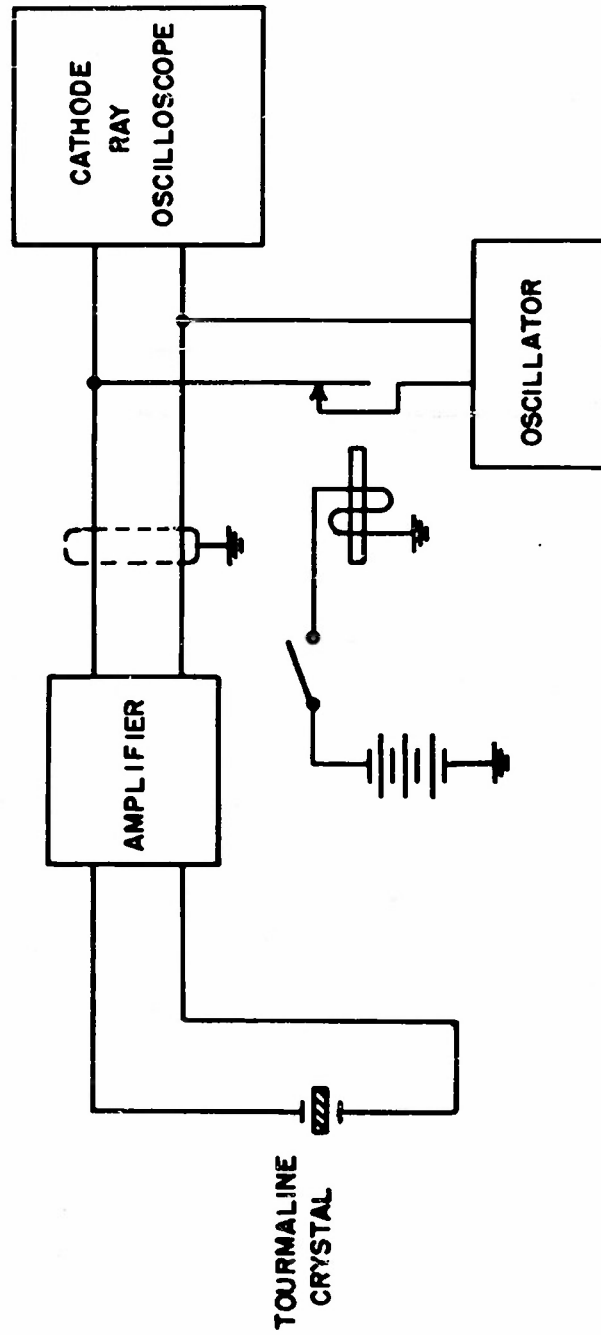

FIG. 5 INSTRUMENTATION FOR RECORDING GAS LEAKAGE

NOTES:

1. PROCEDURE TO BE FOLLOWED IN ASSEMBLY:

A. COAT "O"-RING WITH A LIGHT COATING OF SILICONE GREASE, DOW CORNING DC-3 OR DC-4 OR EQUIVALENT AND INSERT INTO BOTTOM OF TRACER CAVITY.

453171

B. PLACE LEAD GASKET, DR. 453171, UNDER LIP OF PLUG, DWG. 1246002

C. COAT ALL THREADS OF PLUG WITH FUZE THREAD LUTING (UNDILUTED) MADE IN ACCORDANCE WITH NAVY DEPT SPEC. MS 603.

D. SCREW PLUG INTO TRACER CAVITY UNTIL IT SEATS AGAINST PLUNGER RETAINER PLUG, DR. 330168-3, USING A TORQUE OF 40 FT. LBS. \pm 8 FT. LBS.

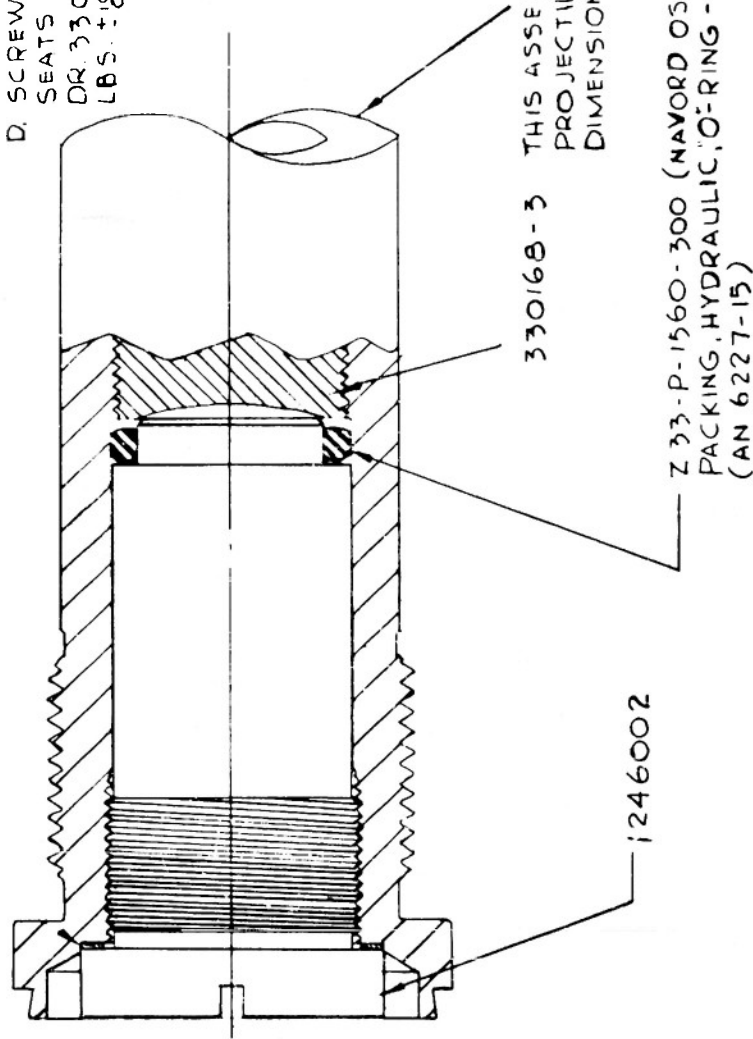

FIG. 6 TRACER CAVITY & PLUG ASSEMBLY DETAIL

FROM BUORD DRAWING NO. 1246001

CONFIDENTIAL
 NAVORD REPORT 2830

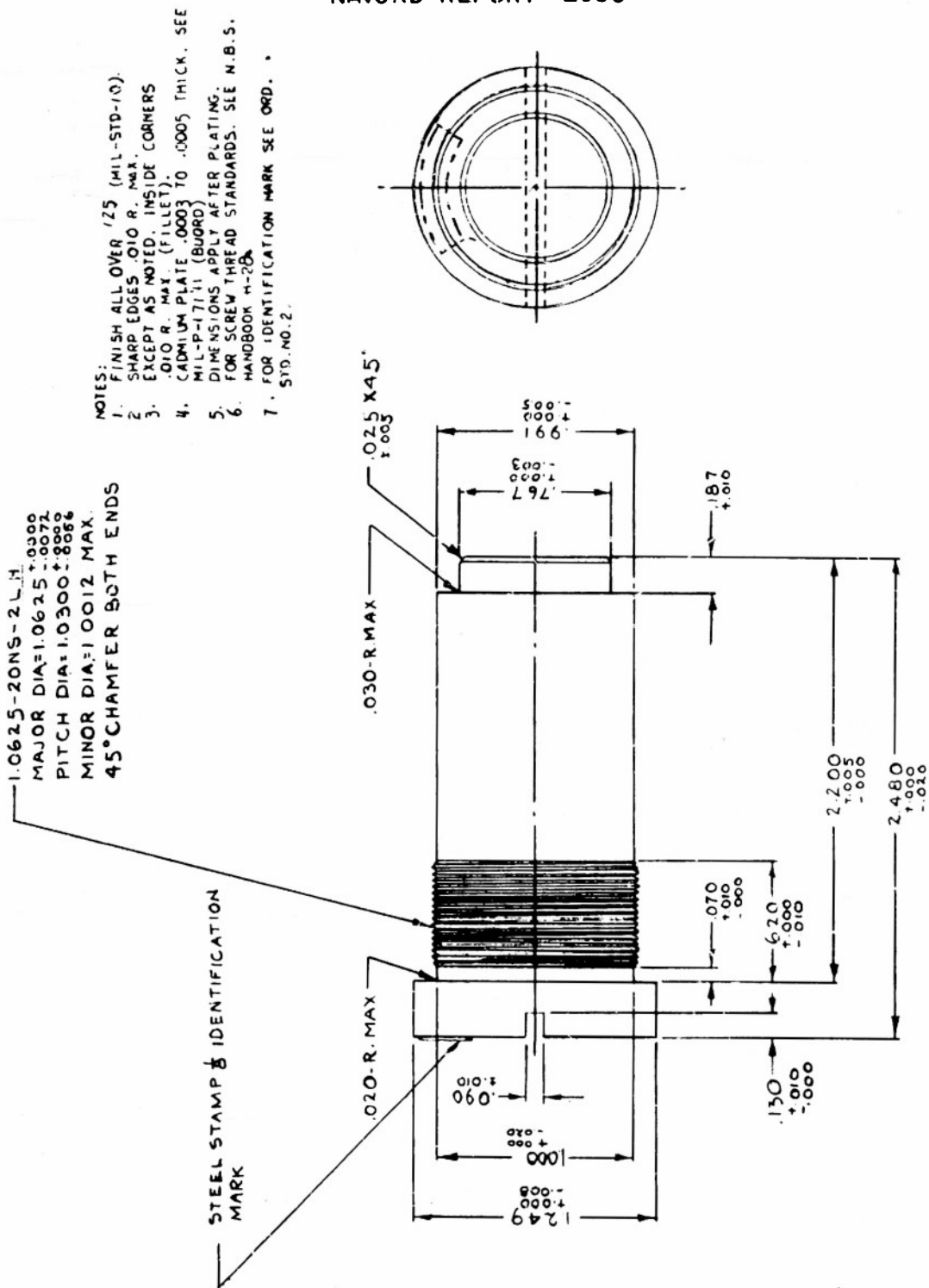

FIG. 7 TRACER CAVITY PLUG
 FROM BUORD DRAWING NO. 1246002

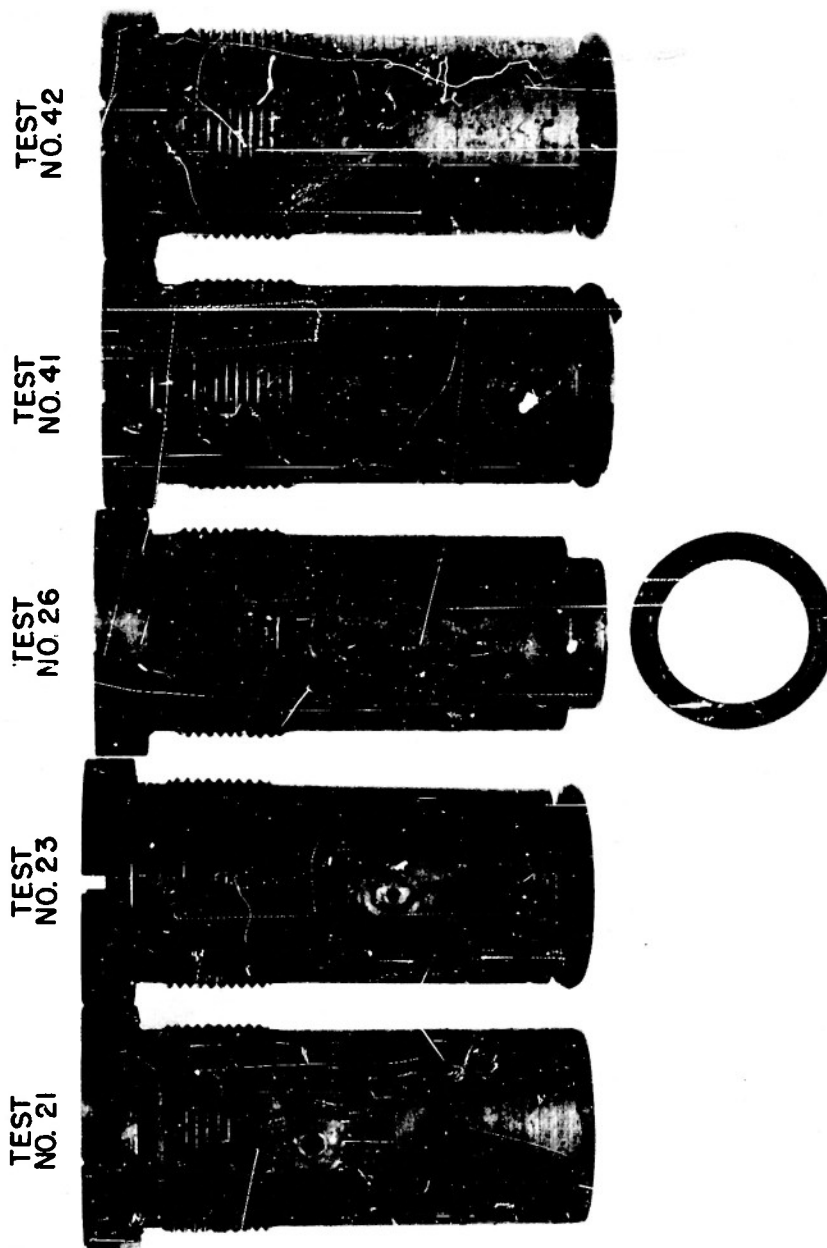

FIG.8 EFFECTS OF GAS EROSION OF A 0.040 HOLE IN MK 5
TRACER WITH AND WITHOUT AN "O" --RING SEAL

CONFIDENTIAL
NAVORD REPORT 2830



FIG. 9 8"/55 PREMATURE WITH MK 48 FUZE

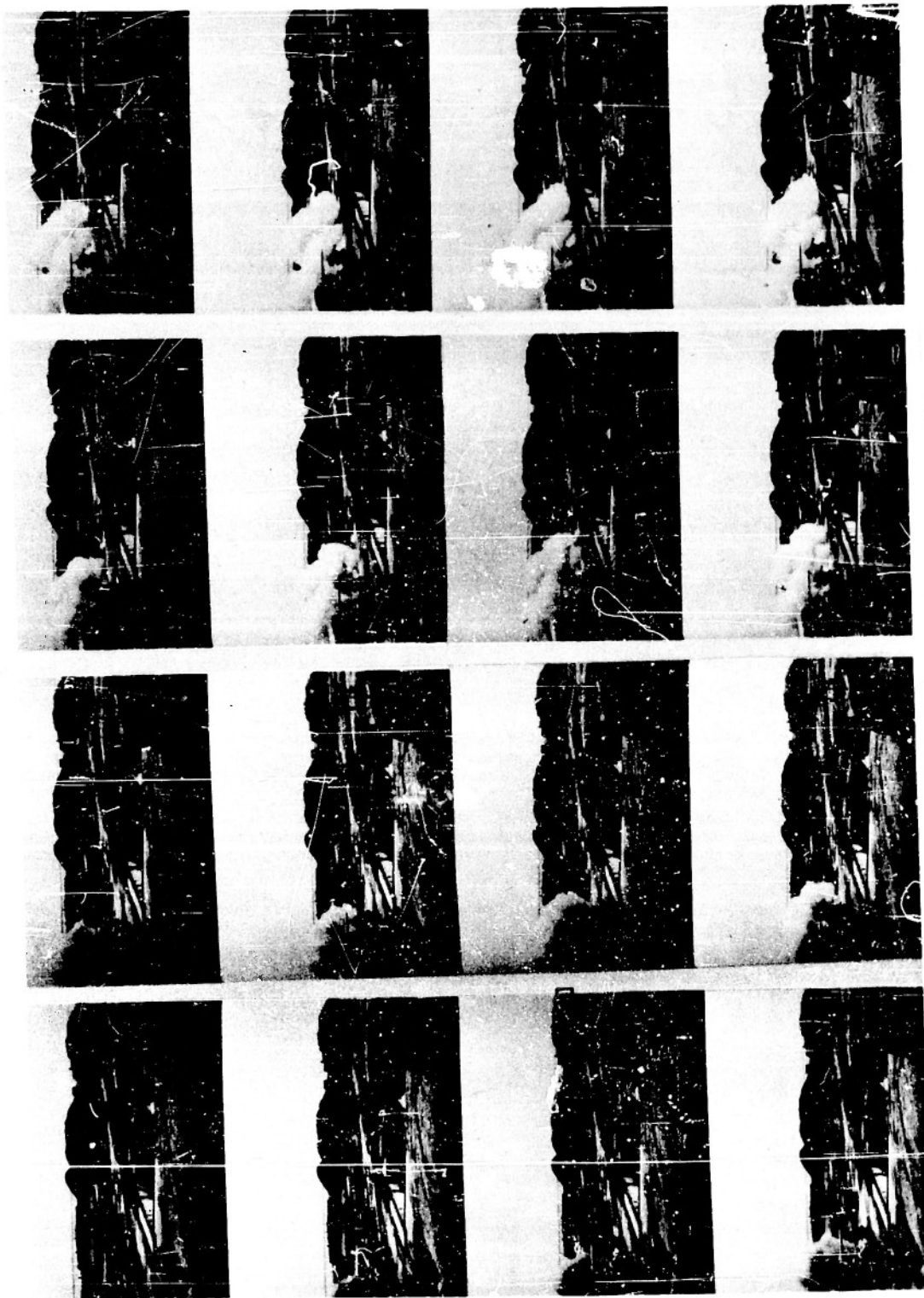

FIG. 10 8"/55 NORMAL FIELD TEST