

UNCLASSIFIED

AD NUMBER

AD039116

LIMITATION CHANGES

TO:

Approved for public release; distribution is unlimited.

FROM:

Distribution authorized to U.S. Gov't. agencies and their contractors;
Administrative/Operational Use; JUN 1954. Other requests shall be referred to Office of Naval Research, Washington, DC.

AUTHORITY

onr ltr, 9 nov 1977

THIS PAGE IS UNCLASSIFIED

THIS REPORT HAS BEEN DELIMITED
AND CLEARED FOR PUBLIC RELEASE
UNDER DOD DIRECTIVE 5200.20 AND
NO RESTRICTIONS ARE IMPOSED UPON
ITS USE AND DISCLOSURE.

DISTRIBUTION STATEMENT A

APPROVED FOR PUBLIC RELEASE
DISTRIBUTION UNLIMITED.

Armed Services Technical Information Agency

Because of our limited supply, you are requested to return this copy WHEN IT HAS SERVED YOUR PURPOSE so that it may be made available to other requesters. Your cooperation will be appreciated.

AD

39116

NOTICE: WHEN GOVERNMENT OR OTHER DRAWINGS, SPECIFICATIONS OR OTHER DATA ARE USED FOR ANY PURPOSE OTHER THAN IN CONNECTION WITH A DEFINITELY RELATED GOVERNMENT PROCUREMENT OPERATION, THE U. S. GOVERNMENT THEREBY INCURS NO RESPONSIBILITY, NOR ANY OBLIGATION WHATSOEVER; AND THE FACT THAT THE GOVERNMENT MAY HAVE FORMULATED, FURNISHED, OR IN ANY WAY SUPPLIED THE SAID DRAWINGS, SPECIFICATIONS, OR OTHER DATA IS NOT TO BE REGARDED BY IMPLICATION OR OTHERWISE AS IN ANY MANNER LICENSING THE HOLDER OR ANY OTHER PERSON OR CORPORATION, OR CONVEYING ANY RIGHTS OR PERMISSION TO MANUFACTURE, USE OR SELL ANY PATENTED INVENTION THAT MAY IN ANY WAY BE RELATED THERETO.

Reproduced by
DOCUMENT SERVICE CENTER
KNOTT BUILDING, DAYTON, 2, OHIO

UNCLASSIFIED

AD No. 3916
ASTIA FILE COPY

Elements of Instrumentation

I. Mathematically Operating Elements (Analog Methods)

Technical Report No. 2
Laboratory for Applied Biophysics
Massachusetts Institute of Technology

June, 1954

ELEMENTS OF INSTRUMENTATION
I. MATHEMATICALLY OPERATING ELEMENTS
(Analog Methods)

by

K. S. Lion

in collaboration with R. A. Davis

Laboratory of Applied Biophysics
(Instrumentation Laboratory)
Massachusetts Institute of Technology
Cambridge, Massachusetts

PREFACE

This report represents a part of a larger undertaking, the goal of which is the collection, analysis, and organization of the methods of instrumentation, i.e. of such methods that are used for scientific investigations or for the construction of scientific or technical instruments.

Almost all instruments are composed of elements such as input transducers, amplifiers, filters, integrators, and meters. The present report deals with mathematically operating elements, or analog computer elements, e.g. elements that add or subtract voltages, or that differentiate or integrate a voltage-time function. The standard elements and a variety of nonconventional mathematically operating elements are described.

This report, however, aspires to be more than just a collection of unrelated methods. For each basic mathematical operation, we have attempted to describe the special requirements of any device to be used in this application, to point out the difficulties inherent in the operation itself, and to provide criteria by which the relative merits of the various devices and any future devices may be evaluated.

We have limited ourselves in this paper to devices with electrical inputs, in which the desired operation is performed on electrical signals. Most of the devices described in this paper have electrical outputs, but some devices with non-electrical outputs have been included, mostly in cases where the importance of the device as a transducer was secondary to its importance as a device capable of performing a mathematical operation on an electrical signal.

As to the presentation, the descriptive physical aspect is emphasized. Mathematical derivations are omitted. Where the derivation is not obvious, references are given. Only references published in ordinary scientific and technical periodicals or textbooks are quoted. Semipublic material, such as theses, technical reports, or patents, is omitted. The role of patent

literature is a very complex problem that may require special consideration in the future.

The coverage of the field of Instrumentation in the existing literature is not homogeneous. Some authors deal with it in generalities and block diagrams, others furnish detailed informative results of investigations on single methods, ranges, limits of application, etc. This state of affairs is necessarily reflected in this report.

The goal of our work is both a practical and a theoretical one. The use of the material collected in a reference book should provide a broad view as well as useful information on any particular aspect of the field and avoid in the future the wasteful repetition of developmental work which frequently exists in research laboratories. Moreover, the analysis of the basic elements of these scientific methods should form a skeleton for a logically coordinated science of Instrumentation.

TABLE OF CONTENTS

| | Page |
|--|------|
| Preface | i |
| Table of Contents | iii |
| General Considerations Concerning Mathematically Operating Elements | 1 |
| Addition and Subtraction | 4 |
| Multiplication and Division | 24 |
| Differentiation | 65 |
| Integration | 86 |
| Acknowledgements | 118 |

General Considerations Concerning Mathematically Operating Elements

The general form of a mathematically operating element is shown in Fig. 1, where

$$z = f_1(x, y). \quad (1)$$

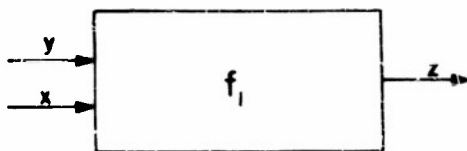

Figure 1.

The problem in instrumentation is to find an appropriate system M which performs the operation expressed by the symbol f_1 to a satisfactory degree. Frequently the solution will differ from the one in Eq. (1) such as

$$z' = a f_1(x, y) + b f_2(x, y) + c f_3(x, y, t) + d f_4(t) + e. \quad (2)$$

The solution may differ from the true value of z by a constant scale factor a . It may also contain a distortion term which is a function f_2 of the independent variables x and y (amplitude distortion) and a term $f_3(x, y, t)$ incorporating the time derivatives of x and y (dynamic error, transient effect, frequency distortion, phase distortion). The solution may further be different from the correct value of z by a time variant component $d f_4(t)$ such as drift or noise, and finally by a constant component e .

The performance of a mathematically operating element is characterized in general by the following factors:

1. The useful range, i.e. the lowest and highest levels of input signals which furnish a useful output signal.

The highest useful level is in general reached when the value of distortion (see second term in Eq. 2) exceeds the maximum permissible error. Sometimes practical considerations limit the highest useful level (power dissipation or voltage breakdown of component parts).

The lowest useful level is in general reached when the relative magnitude of the error or noise-to-signal exceeds the maximum permissible relative error.

2. The input characteristic, i.e.

- a. the level of useful input signals
- b. the input impedance

Both magnitudes together determine the power level of an input signal required by the system.

3. The output characteristic, i.e.

- a. the level of useful output signals
- b. the output impedance

Both magnitudes together determine the power level of an output signal available from the system.

4. The frequency range.

In general input signals vary with time, and an ideal element would follow such variations regardless of the rate of change. However, all mathematically operating elements become unsatisfactory at high rates of change, and some at low rates of change. If a sinusoidal signal of varying frequency is applied to the input of the element, the response will be satisfactory only over a limited frequency range.

5. The accuracy, expressed by the error, i.e. the deviation Δz of the

output signal from the true value of z . This figure incorporates the four last terms of Eq. (2) above. The error also includes variations of the output signal produced by environmental influences, such as temperature, pressure, humidity, stray fields, mechanical vibrations, etc.

6. Constructive considerations. For many practical considerations it is necessary also to consider the size and weight of the element plus the accessory equipment, its cost, the necessity for maintenance,

the power requirements and the use of standard parts for its construction.

Indirect Methods

Where the direct instrumentation of a particular mathematical operation is difficult, it may be advantageous to use indirect methods of performing that operation. Two main indirect methods have been used:

1. Substitution of an equivalent mathematical operation

Example: $xy = \text{antilog}(\log x - \log y)$.

The signals x and y are first applied to two independent logarithm-forming elements. The output signals from these elements are added, and the sum is applied to an antilogarithm system.

2. Implicit (trial and error) methods.

Example: If $(zy - x) = 0$, then $z = \frac{x}{y}$.

The value of z is varied until the equation $zy - x = 0$ is satisfied. The value of z corresponding to solution of the equation is then equal to the desired output signal. Naturally this method may be used only when the equation to be solved has a single root. A servomechanism or other feedback device may be used to solve the equation continuously, and so give a continuous output.

Either of these two indirect methods may permit simpler instrumentation than direct methods.

1. ADDITION AND SUBTRACTION

1.0 General Considerations

1.1 Addition and Subtraction of Voltage Sources

1.11 Series Connection of Voltage Sources

1.12 Parallel Connection of Voltage Sources

1.13 Bridge Circuits for Voltage Sources

1.2 Vacuum Tube Circuits

1.21 Single Vacuum Tube with 2 Inputs

1.22 Differential Vacuum Tube Amplifier

1.23 Vacuum Tubes in Parallel

1.24 Parallel Voltage Sources with Feedback Amplifiers

1.3 Addition of Impedances (Resistances)

1.31 Resistances in Series

1.32 Resistances in Parallel

1.33 Resistances in Bridge Circuits

1.4 Addition by Means of Transducers

1.41 Meter with Multiple Input

1.42 Synchros

1. Addition and Subtraction

1.0 General Considerations

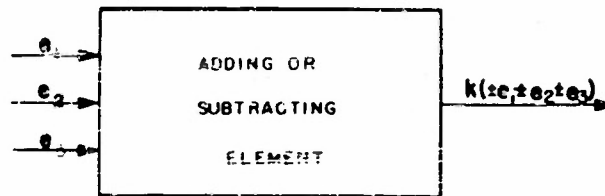

Figure 2

The general form of an adding or subtracting element is shown in Fig. 2. Since $e_1 - e_2$ is equal to $e_1 + (-e_2)$, any of the methods of addition can be used for subtraction if some means is available for inverting the signal.

Three fundamental methods for addition and subtraction of voltages - the series, the parallel, and the bridge method - are described in Section 1.1. In some cases it is more practical to convert or transform the input voltages into other equivalent voltages or currents, and to add the latter ones. This is primarily required when interaction between the different input voltages is to be minimized. Vacuum tube methods suitable for this purpose are described in Section 1.2.

If the input signals are presented in the form of impedance or resistance levels, a summation operation can be carried out by networks described in Section 1.3.

A number of electrical methods which are different in scope from the foregoing three sections are presented in Section 1.4. They have in common that the addition or subtraction of the input signals is performed with transducers and appears as a mechanical displacement (meter output).

1.11 Series Connection of Voltage Sources

Addition and subtraction of voltages may be obtained by connecting the input generators e_1, e_2, e_3 in series according to Fig. 3. The method requires floating potentials of all but one of the input circuits. If such is

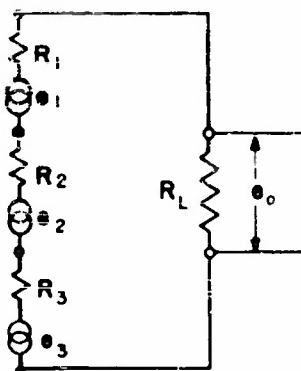

Figure 3

not the case one or several of these input voltages must be converted into voltages of floating potential (e.g. by means of transformers).

The output voltage for the circuit, Fig. a, is

$$e_o = (e_1 + e_2 + e_3 + \dots) \frac{R_L}{R_1 + R_2 + R_3 + \dots + R_L}$$

where e_o, e_1, \dots are instantaneous voltages. R_1, R_2, R_3 include the internal impedances of the source. For infinite load impedance ($R_L \gg R_1, R_2, R_3$) the output voltage is $e_o = e_1 + e_2 + e_3$.

The output impedance is

$$R_o = (R_1 + R_2 + R_3) \cdot \frac{R_L}{(R_1 + R_2 + R_3 + R_L)}$$

The input impedance for any one of the sources is the sum of the other source impedances plus the load resistance, as for source e_1 , the input impedance is

$$R_i = R_2 + R_3 + R_L.$$

Thus, for infinite load impedance R_L , R_i too is infinite.

The mutual coupling between two input circuits, i.e. the current increment produced at one input by the voltage increment at another input is

$$\frac{\Delta i_2}{\Delta e_1} = \frac{1}{R_1 + R_2 + R_3 + R_L}$$

and becomes zero for $R_L = \infty$.

The method is applicable for DC voltages. AC voltages can also be used for arithmetic additions if all generators operate in phase for addition, or 180° out of phase for subtraction. If the output voltage varies from positive to negative values, a phase sensitive indicator must be employed for the measurement of e_o , or the zero point of the meter must be shifted electrically towards the center of the scale by an auxiliary voltage. The useful range and the accuracy of the method are limited only by the system which measures the output voltage e_o . Parallel capacitances and capacitances to ground of the single input sources are likely to cause difficulties at high frequencies.

It is natural that a manuscript of this type will contain a number of errors and omissions. To improve future editions we would like to be informed of any such errors and also of any items the reader would like to see included in a compilation of instrumentation elements. Your cooperation will be deeply appreciated.

K. S. Lion
Room 16-725
Massachusetts Institute of Technology
Cambridge 39, Massachusetts

1.12 Parallel Connection of Voltage Sources

The voltages $e_1, e_2, e_3 \dots$ are connected in series with the impedances or resistances R_1, R_2, R_3 , according to Fig. 4. R_1, R_2, R_3 include the internal impedances of the sources.

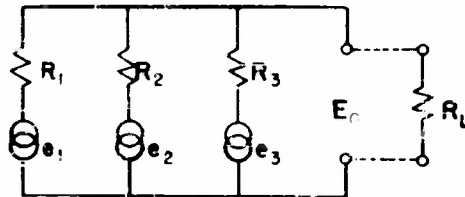

Figure 4

The output voltage is

$$e_o = \frac{e_1(R_2 R_3) + e_2(R_1 R_3) + e_3(R_1 R_2)}{R_1 R_3 + R_2 R_3 + R_1 R_2 + \left(\frac{R_1 R_2 R_3}{R_L}\right)}$$

or

$$e_o = \frac{G_1 e_1 + G_2 e_2 + G_3 e_3 + \dots}{G_1 + G_2 + G_3 + \dots + G_L}$$

where $G = \frac{1}{R}$.

If the resistance of the load is large ($R_L \gg R_1, R_2, R_3$) Eq. (1) becomes

$$e_o = a \cdot e_1 + b \cdot e_2 + c \cdot e_3 \quad (2)$$

where

$$a = \frac{G_1}{G_1 + G_2 + G_3} = \frac{G_1}{\Sigma G}, \quad b = \frac{G_2}{\Sigma G}, \quad c = \frac{G_3}{\Sigma G}$$

for $R_1 = R_2 = R_3$, the output voltage is

$$e_o = \frac{1}{n} (e_1 + e_2 + e_3) \quad (3)$$

where n is the number of sources (e.g. $n = 3$ in Fig. 4).

The output impedance for resistive elements (as in Fig. 4) is

$$R_o = \frac{1}{\frac{1}{R_L} + \frac{1}{R_1} + \frac{1}{R_2} + \frac{1}{R_3}}$$

The input impedance for any source, e.g. for e_1 , is

$$R_i = \frac{1}{\frac{1}{R_2} + \frac{1}{R_3} + \frac{1}{R_L}}$$

The mutual coupling factor (e.g. the variation of current in the leg 1 produced by a variation of the voltage e_2) is

$$\frac{\Delta i_1}{\Delta e_2} = \frac{R_3}{R_1 R_2 + R_2 R_3 + R_3 R_1 + \frac{R_1 R_2 R_3}{R_L}}$$

The method is particularly applicable if one terminal of each source is to be kept at the same potential (e.g. ground potential). For accurate performance the resistances R_1 , R_2 , R_3 or their ratios must be kept constant. (J. Lentz and I. A. Greenwood, Jr., *Electronic Instruments*, Rad. Lab. Series, Vol. 21, Sec. 3.2). The useful range and the accuracy of the method are limited only by the system which measures the output voltage e_o . Accuracy for transient response requires that R_1 , R_2 , R_3 be either pure resistances or reactances (capacitances) or that they have the same time constants. For subtraction one or several of the input voltages have to be inverted by means of transformers, tubes or other inverting elements. (For further references see D. MacRae, Jr., A. H. Frederick, and A. S. Bishop, *Waveforms*, Rad. Lab. Ser., Vol. 19, Sec. 18.2). The same circuit with feedback amplifier at the output is described in Sec. 1.24 below.

1.13 Bridge Circuit for Voltage Sources

The DC or AC voltages to be added or subtracted are e_1 and e_2 in Figure 5. One voltage source must be floating. Either a balanced bridge

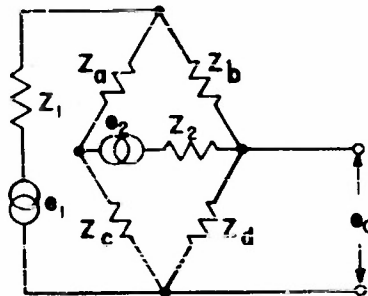

Figure 5

($Z_a : Z_b = Z_c : Z_d$) or an equal arm bridge ($Z_a = Z_b = Z_c = Z_d = Z$) may be used. In the latter case the output voltage is

$$e_o = \frac{Z}{2} \left(\frac{e_1}{Z + Z_1} + \frac{e_2}{Z + Z_2} \right)$$

The input impedance for either input e_1 or e_2 is Z .

The mutual coupling between the sources e_1 and e_2 is zero.

The output impedance is

$$Z_o = Z \frac{2Z^3 + Z^2(4Z_1 + 5Z_2) + Z(8Z_1Z_2 + 2Z_2^2) + 3Z_1Z_2^2}{8Z^3 + Z^2(8Z_1 + 8Z_2) + Z(14Z_1Z_2 + 4Z_2^2) + 4Z_1Z_2^2}$$

for $Z_1 = Z_2 = Z_S$.

$$Z_o = Z \frac{2Z^3 + 9Z^2Z_S + 10ZZ_S^2 + 3Z_S^3}{8Z^3 + 16Z^2Z_S + 20ZZ_S^2 + 4Z_S^3}$$

for $Z_1 = Z_2 = Z$

$$Z_o = \frac{Z}{2} .$$

1.2 Vacuum Tube Circuits

The use of vacuum tubes for electrical analogue addition is, fundamentally, not different from the methods listed under Sections 1.11 and 1.12 above. Vacuum tubes offer, however, some practical advantages.

The high input impedance of such tubes reduces the power requirement for the input signals. The almost complete isolation of plate and grid circuits in a vacuum tube reduces the mutual coupling between multiple inputs. Feedback methods permit the closer approximation of ideal performance. Offsetting these advantages are the inherently greater instability and complexity of vacuum tube circuits. A circuit featuring high attainable accuracy and great flexibility is the parallel input-d.c. feedback method described under 1.24.

1.21 Single Vacuum Tube with Two Inputs

In the circuit of Fig. 6 the input voltage e_1 is applied between grid and ground, and the voltage e_2 between cathode and ground.

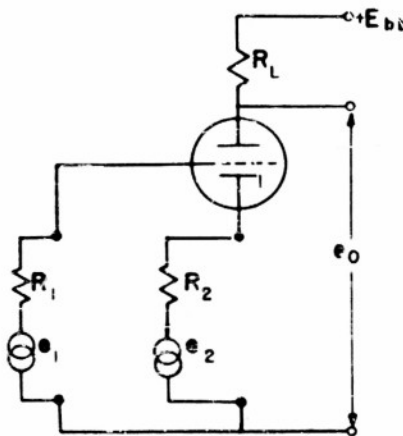

Figure 6

The signal output voltage is

$$e_o = \frac{R_L}{r_p + R_L + (\mu + 1)R_2} (\mu \cdot e_1 - (\mu + 1)e_2)$$

or, for $\mu \gg 1$,

$$e_o = \frac{\mu \cdot R_L}{r_p + R_L + \mu R_2} (e_1 - e_2).$$

The output voltage depends primarily upon the difference ($e_1 - e_2$). It also depends upon the absolute magnitude of e_1 and e_2 . The difference ($e_1 - e_2$) affects the output voltage μ times more than does the common mode level change.

The output impedance is

$$R_o = \frac{R_L (r_p + R_2 (\mu + 1))}{R_L + r_p + R_2 (\mu + 1)}.$$

The input impedance to the grid for e_1 is usually several megohms; the input impedance to the cathode for e_2 is low and is

$$R_o = \frac{r_p + R_L}{\mu + 1}.$$

A generator with low input impedance is required for e_2 .

A modification of this circuit which reduces the zero shift of e_2 caused by common mode level change is given by R. Kelner, J. W. Gray, E. F. MacNichol, Jr., Direct Coupled Discriminators, Rad. Lab. Ser., Vol. 19, Waveforms, Sec. 9.22.

1.22 Differential Vacuum Tube Amplifier

A. Fig. 7 shows a symmetrical differential circuit where the input voltages e_1 and e_2 are applied to the grids of two triode systems. The use of two equal systems in one envelope reduces zero shift of the output voltage caused by variation of the cathode temperature.

The output voltage for triodes with identical linear characteristics is

$$e_o = \frac{\mu R_L}{R_L + r_p} (e_1 - e_2)$$

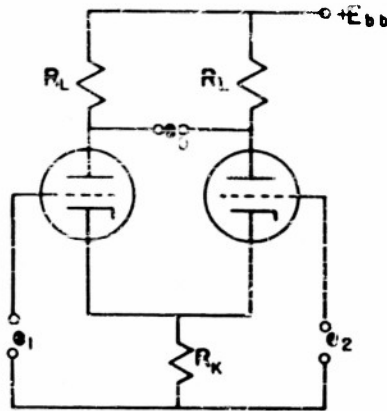

Figure 7

unaffected by R_K or plate supply variation (unless the plate supply voltage affects the values of μ and r_p).

The output impedance is

$$R_o = \frac{2R_L \cdot r_p}{R_L + r_p}.$$

The tubes should be carefully matched for accurate results.

A complete analysis and some modified circuits are given by John W. Gray, *Direct Coupled Amplifiers*, Rad. Lab. Ser., Vol. 18 (Amplifiers) Sec. 11.10.

B. Fig. 8 shows a modification of the symmetrical differential amplifier. The resistor R_K is substituted by a triode operated as a constant current element. This effects a virtual increase of R_K to infinity and improves the linearity. The output level (potential of A or B) is approximately 200 volts and changes by only 2 volts as the common mode level of inputs changes from -50 to +150 volts. Using a 6SL7, the output voltage e_o will in general vary less than 0.1 volt for a 200 volt common mode change of the input level. (R. Kelner, J. W. Gray, E. F. MacNichol, Jr., *Direct Coupled Discriminators*, Rad. Lab. Ser., Vol. 19, Waveforms, Sec. 9.22, p. 360.)

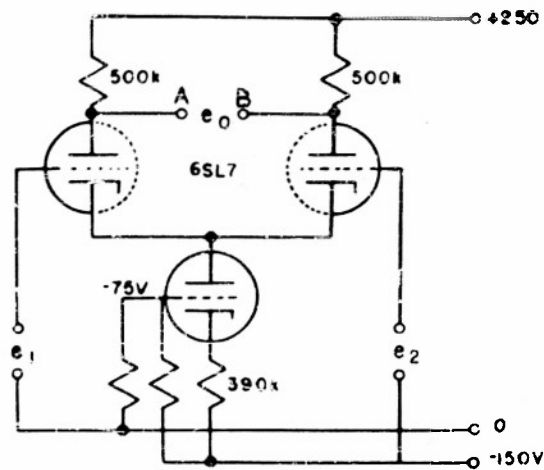

Figure 8

C. Fig. 9 shows a second modification of the symmetrical differential amplifier with single ended (one side grounded) output.

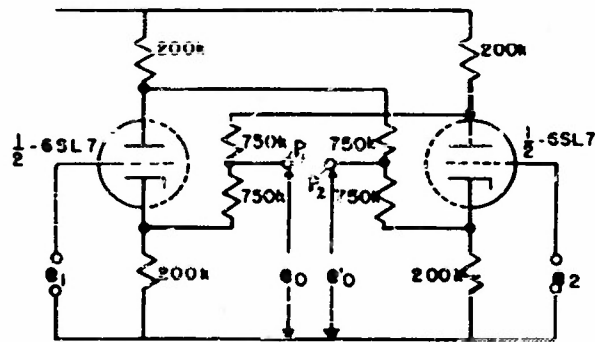

Figure 9

The input signals are applied between grid and ground of either tube. The output voltage between P_1 and ground is approximately

$$e_o = \frac{e_1 - e_2}{2} + E_{bc};$$

the one between P_2 and ground is

$$e'_o = \frac{e_2 - e_1}{2} + E_{b'o}.$$

(E_{bo} is a constant additive component.) The output is accurate to within 0.5 per cent over a range of 80 volts for each input. See D. MacRae, Jr., A. H. Frederick, A. S. Bishop; Addition and Subtraction by Means of Vacuum Tubes, Rad. Lab. Ser., Vol. 19, Waveforms, Sec. 18.3, p. 646, where a similar single ended output subtractor circuit with asymmetrical tube arrangement is described.

1.23 Vacuum Tubes in Parallel

A. Each of the variational input voltages e_1 , e_2 , e_3 in Fig. 10 is applied between cathode and grid of a vacuum tube, thus controlling the plate current and producing on the common load resistor R_L a signal

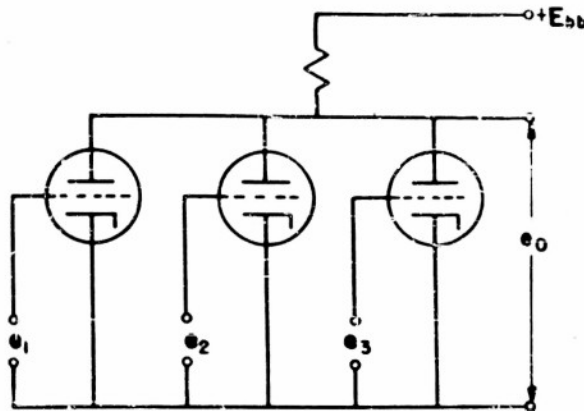

Figure 10

output voltage

$$e_o = \frac{g_{m_1} e_1 + g_{m_2} e_2 + g_{m_3} e_3}{R_L + \left(\frac{1}{r_{p_1}} + \frac{1}{r_{p_2}} + \frac{1}{r_{p_3}} \right)} \quad (1)$$

(assuming linear characteristics). For small load resistances ($R_L \ll r_p$, pentodes) Eq. (1) is simplified to

$$e_o = R_L (g_{m1} \cdot e_1 + g_{m2} \cdot e_2 + g_{m3} \cdot e_3).$$

If all tubes have the same transconductance g_m , the output voltage is

$$e_o = R_L \cdot g_m (e_1 + e_2 + e_3).$$

The output impedance is, in good approximation,

$$P_o = \frac{r_p}{n}$$

where n is the number of input tubes (e.g. 3 in Fig. 10).

The input impedance for the single sources e_1 , e_2 , e_3 is usually several megohms.

The mutual coupling between the inputs is negligible, except for capacitive coupling of the input sources.

Triodes offer the advantage of simplicity. Pentodes are preferable where high speed operation and, therefore, small input interelectrode capacitances are required.

B. A variation of the multiple tube adding circuit is shown in Fig. 11. The input voltages e_1 , e_2 , e_3 are applied between the grids of the tubes and ground. The load resistance R_K between the common cathode connection and ground produces a degenerative effect.

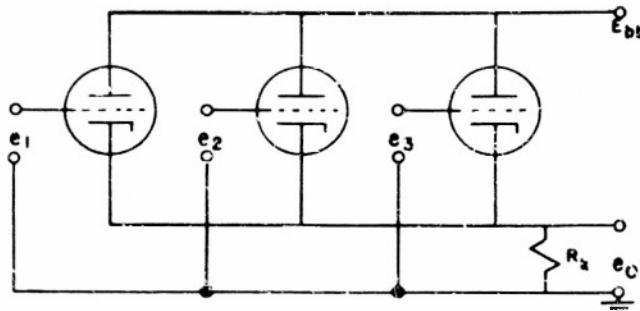

Figure 11

The output voltage, within the linear range of operation is

$$e_o = \frac{\mu(e_1 + e_2 + e_3)}{n(\mu + 1) + r_p/R_K}$$

for $\mu \gg 1$ and $n \cdot \mu \gg r_p/R_K$

$$e_o \approx \frac{1}{n}(e_1 + e_2 + e_3)$$

where n is the number of input voltages (e.g. 3 in Fig. 11).

The output impedance is

$$R_o = \frac{R_K \cdot r_p}{r_p + n R_K (\mu + 1)}$$

or, for $R_K(\mu + 1) \gg r_p$, and $\mu \gg 1$,

$$R_o = \frac{r_p}{n\mu} = \frac{1}{n \cdot g_m}$$

The input impedances for the individual sources e_1, e_2, e_3 are usually several megohms.

The mutual coupling between the input sources is zero, with the exception of capacitive coupling.

1.24 Parallel Voltage Sources with Feedback Amplifiers

The use of a feedback amplifier in the output increases the precision of the method, provides less mutual coupling between the input circuits by decreasing the input impedance, and can be built to decrease the output impedances. The method is applicable for AC and DC. For the arrangement shown

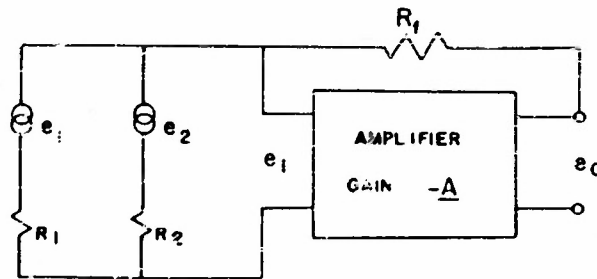

Figure 12

in Fig. 12, the output voltage is

$$e_o = - \frac{e_1/R_1 + e_2/R_2}{\frac{1}{R_f} + \frac{1}{A} \left(\frac{1}{R_1} + \frac{1}{R_2} + \frac{1}{R_f} \right)}$$

if the output R of A is small. If the gain A of the amplifier is large (the minus sign denotes a reversal of the output polarity with respect to the input), the second term in the denominator can be neglected and the output voltage is

$$e_o = - \left(e_1 \frac{R_f}{R_1} + e_2 \frac{R_f}{R_2} \right).$$

If A is large, the input voltage to the amplifier is kept nearly constant and very small. This has the effect that the input impedance to the amplifier is small, $R_i = R_f / (1 + A)$. The input impedance for any source is, therefore, approximately zero.

The mutual coupling is

$$\frac{\Delta i_2}{\Delta e_1} = \frac{R_F}{A \cdot R_1 \cdot R_2}$$

and tends to zero for large gain A. (Ref. D. MacRae, Jr., A. H. Frederick, A. S. Bishop, Mathematical Operation on Waveform, Rad. Lab. Series, Vol. 19, Waveforms, Sec. 18.3.)

1.3 Addition of Impedances (Resistances)

If the input signals are presented in the form of impedances or impedance variations (usually resistance variations) a sum or difference formation can be obtained in two ways. One way consists of converting the resistance variation into equivalent voltage variations and using one of the methods for addition and subtraction of voltages (See 1.1 and 1.2). Another way consists of adding or subtracting the resistances with appropriate networks and obtaining an output signal in the form of an impedance.

Three principal methods are available. The impedances are either arranged in series (Sec. 1.31) or in parallel (1.32) or in a bridge circuit (1.33). The output impedance representing the result can be measured with any one of the customary methods. Most commonly used are ohm meters (usually hyperbolic scale), constant current sources and voltmeters (linear scale), and ratio meters, (the indication is independent of supply voltage variation). Higher accuracy at the expense of speed can be obtained with the Wheatstone bridge operated with manual or servo system balance. Some representative circuits are indicated.

1.31 Resistances in Series

A. The total (output) resistance of the circuit in Fig. 13 is

$$R_o = R + \Delta R_1 + \Delta R_2 + \Delta R_3.$$

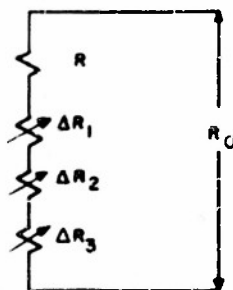

Figure 13

If the resistances are replaced by impedances, these must either be pure reactances or must all have the same time constants.

B. An application of this circuit for analogue computers is shown in Fig. 14. With scales arranged like R_1 and R_2 , the total resistance increases

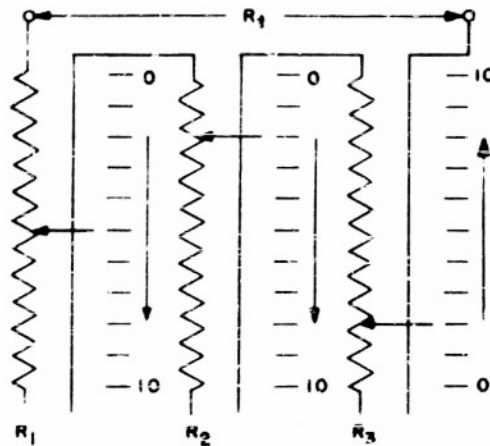

Figure 14

with increased setting of the resistance scale, and the result R_0 is equal to the sum $(R_1 + R_2 + R_3)$. With a scale arranged in opposite direction (R_3) the total resistance diminishes with increased scale setting and the result indicates the difference $R_0 = (R_1 + R_2) - R_3$. For such setups the 0 point of the meter has to be brought in the middle of the scale so that for R_1 , R_2 and R_3 set at zero the meter reads zero and can indicate negative values at increased setting (decreased value) of R_3 .

1.32 Resistances in Parallel

If the scales of the resistances R_1 , R_2 , R_3 are calibrated proportionally to the conductance $G = 1/R$ an arrangement according to Fig. 15 can be used.

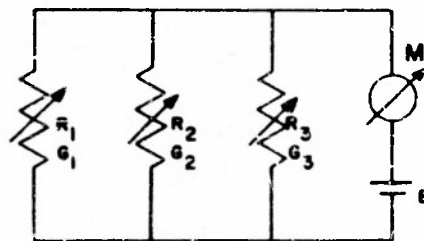

Figure 15

The total current measured with the meter M is $I = E \cdot \left(\frac{1}{R_1} + \frac{1}{R_2} + \frac{1}{R_3} \right) = E \cdot (G_1 + G_2 + G_3 \dots)$.

1.33 Resistances in Bridge Circuits

A. The resistances R_1 , R_1' , R_3 and R_2 , R_2' , R_4 in Fig. 16 are

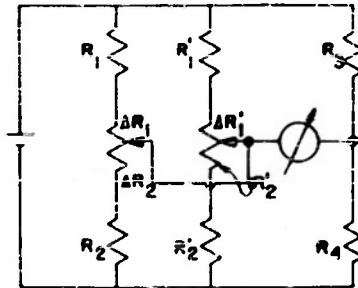

Figure 16

approximately equal. If the resistance variations $\Delta R \ll R$, then the current i_M in the diagonal is approximately proportional to the sum of these variations. (J. Krönert, ATM J 0821-1, 1932).

B. Modified Wheatstone Bridge

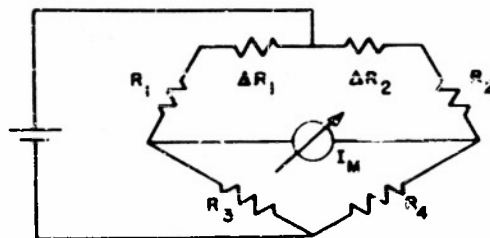

Figure 17

The current i_M in Fig. 17 is proportional to the resistance variations $\Delta R_1 - \Delta R_2$. (Method of Grüss and Siebert, Arch. Techn. M. J 0821-1, 1932).

1.4 Addition by Means of Transducers

The following methods use transducers as adding or subtracting elements; the result is indicated by the deflection of a meter or by the rotation of a servo system. The input signals may be voltages (1.41) or mechanical positions of a synchro (1.42).

1.41 Meter with Multiple Input*

The deflection of the differential moving coil meter shown in Fig. 18 is proportional to the current difference ($i_1 - i_2$). If one of the current connections is reversed, the meter will read the sum ($i_1 + i_2$). Other meter types

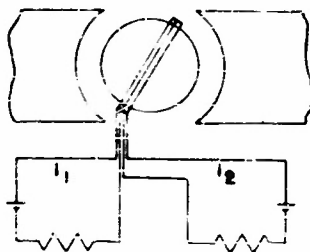

Figure 18

for DC can be similarly adopted with multiple input terminals. Particularly suitable are those types with fixed coils, such as iron vane types, electro-dynamometers with multiple inputs to a subdivided stationary coil and a constant auxiliary current applied to the moving coil. Application of AC may introduce mutual coupling between the different input circuits. Where this coupling causes undesirable effects, the AC inputs can be rectified and the direct currents added.

*The exact description of this instrument will be given in the section on transducers.

1.42 Synchros

The following method can be applied if the input signals can be converted into mechanical rotation of a synchro axis.

The two rotors of the synchro motors I and II in Fig. 19 are connected to the AC supply line, inducing in each of the three stator windings S_1 , S_2 , S_3 voltages of a relative magnitude depending upon the positions of the rotors. The stator windings of one synchro motor are connected to the rotor of the differential synchro D; the stator windings of the other synchro motor are connected to the stator of D. The rotor of D will indicate the difference of the angular positions of I and II. If one pair of leads is reversed (e.g. S_1 and S_3), the differential synchro will indicate the sum of the rotor positions of the two synchro motors. The

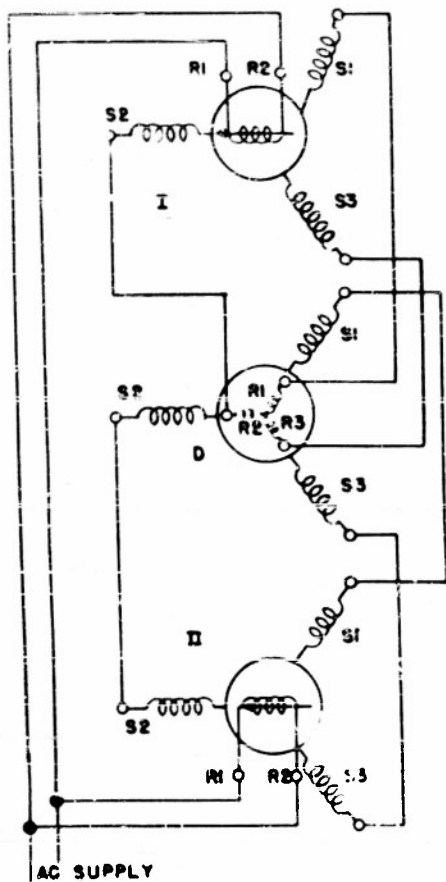

Figure 19

minimum error available is in the order of 0.1° . The accuracy varies in different ranges of angular position. (See W. F. Goodell, Jr., *Rotary Inductors*, Rad. Lab. Ser., Vol. 17, Components Handbook, Sec. 10.4 and 10.5, p. 326. F. B. Berger, *Electromechanical Modulator*, Rad. Lab. Ser., Vol. 19, Chapter 12.)

2. MULTIPLICATION AND DIVISION

- 2.0 General Considerations.
- 2.1 Circuit Elements as Analog Multipliers
 - 2.11 Single Multiplying Circuit Elements
 - 2.12 Multiplying Elements with Servo Systems
- 2.2 Amplitude and Frequency Modulation System for Analog Multiplication
- 2.3 Pulse Methods for Analog Multiplication
 - 2.31 Electronic Switch Method
 - 2.32 Pulse Coincidence Methods
 - 2.33 Time Selection Method
- 2.4 Electron Beam Analog Multipliers
 - 2.41 Split Target Cathode-Ray Tube Multiplier
 - 2.42 Crossed Field Cathode-Ray Tube Multiplier
- 2.5 Transducers as Analog Multipliers
 - 2.51 Electrodynamometer
 - 2.52 Ratio Meter
- 2.6 Multiplication by Logarithmic Methods
- 2.7 Multiplication by Square Law Method
 - 2.71 Isolation of the Product by Cancellation of the Undesired Terms
 - 2.72 Isolation of the Product by Frequency Selection
- 2.8 Multiplication of resistances
 - 2.81 Bridge Methods
 - 2.82 Addition on Logarithmic Scales

2. Multiplication and Division

2.0 General Considerations

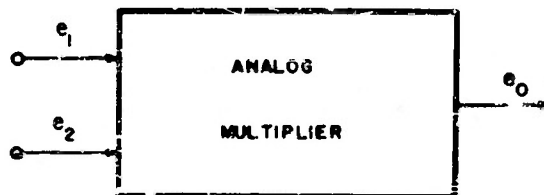

Figure 2.1

The general form of a physical analog multiplier system is shown diagrammatically in Fig. 2.1, where

$$e_0 = a(e_1 \cdot e_2).$$

The magnitudes e_1 and e_2 are the electrical input signals; e_0 is the output signal.

Multiplication and division, being intimately related mathematical operations, are discussed together. Division can be performed with any multiplier by means of indirect or implicit methods.

While very satisfactory methods of electrical analog addition and subtraction are available, no completely satisfactory method of electrical analog multiplication or division has as yet been devised. The great output range required, equal to the product of the input ranges, is one of the greatest difficulties for satisfactory multiplication.

All multipliers are limited by practical considerations in their range, accuracy, and speed of response. Some multipliers have inherent limitations of a more fundamental nature. A perfect multiplier operates in four quadrants; i.e. the sign of its output changes with the sign of each of its inputs. For certain multipliers the sign of the output is independent of one or both of the input signals. In these cases the multiplier is said to be capable of operation in two or one quadrants, respectively.

The input signals (factors) are generally available in the form of variable voltages or currents (2.1 to 2.7), but may be presented in the form of variable resistances or impedances (2.8).

The simplest form of an analog multiplier is a circuit element with an output proportional to the product of two input voltages or currents (2.11). However, none of the available circuit elements of this type furnishes satisfactory results over an extended range of operation. Better results are obtained by using these elements in connection with servo systems (2.12).

In some cases it is advantageous to use the input signals for the modulation of AC sources (2.2) and carry out the multiplication with a discriminator.

Another group of methods tries to solve the problem by converting the input signals into pulses (2.3) and obtaining the desired result by measurement of the pulse average (2.31) by probability methods (2.32) or by a time selection method (2.33).

The use of electron beams for the performance of analog multiplication (2.4) provides for relatively fast methods, requiring, however, special cathode-ray tubes (2.41) or special feedback systems (2.42).

The application of output transducers for multiplication purposes leads to a mechanical output (2.5). The result appears as the deflection of a meter. A voltage output can be obtained from such devices indirectly by means of input transducers or servo systems (example 2.51B).

An entirely different way of electrical analog multiplication is the one by equivalent operations, such as the addition of logarithm (2.6) and the use of square law devices (2.7). Such operations are more easily instrumented in some cases than direct multiplication, but both methods require non-linear devices that must be stable, accurate, and of extended range. The logarithmic method is, of course, inapplicable for negative values.

2.1 Circuit Elements as Analog Multipliers

Certain circuit elements, such as vacuum tubes, transistors, and thermistors, whose currents are functions of the product of two or more inputs, may form adequate physical systems on the basis of which analog multipliers may be developed. In general these systems will not have outputs strictly proportional to the product of two variables, at least over any extended range. Many of these devices, however, will have outputs proportional to the product of one variable and some function of another variable. Although very simple in principle, all these systems have a very restricted range of operation, and usually exhibit instability and drift, in particular when operated with DC signals.

2.11 Single Circuit Elements

A1. Vacuum Tubes

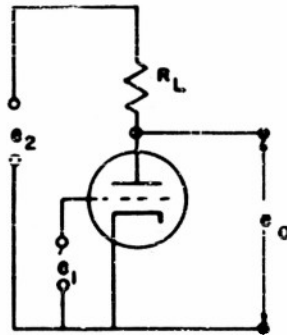

Figure 2.2

The output voltage e_0 in Figure 2.2 is, within a restricted range, approximately proportional to voltage e_1 applied to the grid and to the voltage e_2 applied to the plate

$$e_0 = K \cdot e_1 \cdot e_2.$$

The proportionality range is small. For a 6K6 connected as a triode, grid voltages between 0 and -20 V and plate voltages of less than 25 volts furnish

acceptable results. The load impedance R_L should be small; a transformer with low primary impedance is recommended for AC operation.

A2. The operation can be improved by the setup of Figure 2.3.

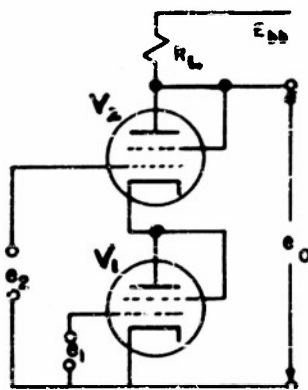

Figure 2.3

The tube V_2 acts as a cathode follower; the tube V_1 as a variable cathode impedance. The circuit may be used for DC and AC operation.

A3.

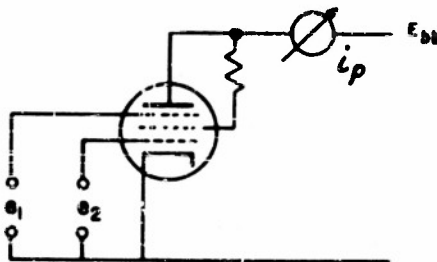

Figure 2.4

In the circuit of Figure 2.4 the plate current is $i_p = a \cdot e_1 \cdot e_2$, i.e. approximately proportional to the product of both grid voltages. Tubes 6SA6 and 6SA7 are recommended for this purpose.

For references for all three methods, see F. B. Berger and D. MacRay, Jr., Waveforms, Vol. 19, Rad. Lab. Ser., Chap. 19.3, p. 669, 1st ed., 1949.

A4. A small AC signal e_1 and a variable DC signal e_2 are applied between grid and cathode of a pentode, Figure 2.5. The mutual conductance of the

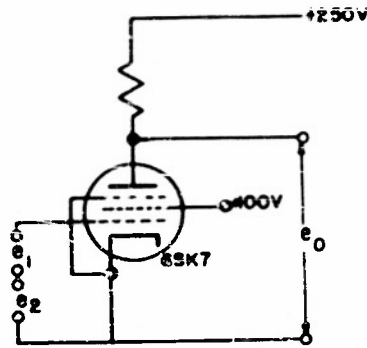

Figure 2.5

tube varies with the applied grid bias (signal e_2); the output signal (AC component) e_o is approximately proportional to the product $e_1 \cdot e_2$. A 6SK7 tube is recommended, operated with $e_p = 250$ V, $e_{g2} = 100$ V and a grid voltage ($e_1 + e_2$) between -1 and -10 volts (Ref.: J. Lentz and I. A. Greenwood, Jr. Vol. 21, Rad. Lab. Series, p. 53).

B. Non-linear Passive Systems

An input voltage e_1 (Figure 2.6) is applied to the series combination of a resistor R and a thermistor T . The resistance of R should be small compared to that of T . The current is then approximately e_1/T_1 and the output voltage is,

$$e_o = \frac{R \cdot e_1}{T}$$

The resistance of T varies with temperature which, in turn, can be controlled by a voltage e_2 , so that

$$e_o = \frac{R \cdot e_1}{f(e_2)}$$

The method is subject to large errors and instability with time and is limited by the time constant of the thermistor.

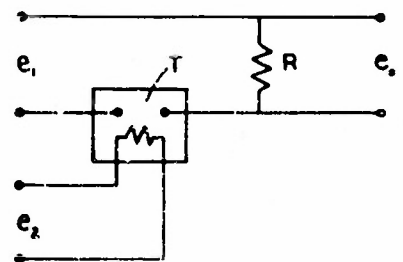

Figure 2.6

C. Voltage Dividers

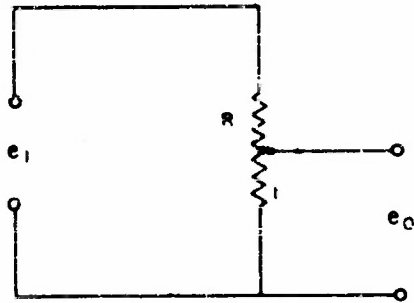

Figure 2.7a

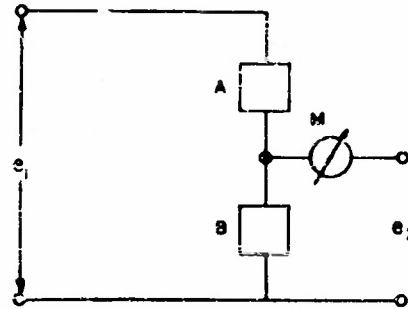

Figure 2.7b

The signal e_1 in Figure 2.7a is applied to the voltage divider; the output voltage is

$$e_o = \frac{r}{R} \cdot e_1 = f \cdot e_1$$

i.e. the output signal is proportional to the product of the input voltage and the attenuation factor f . The factor f can be varied in response to a signal, for instance with a servo system. The multiplication system thus formed is very stable and capable of the highest accuracy. One can also apply two input signals, as e_1 and e_2 in Figure 2.7b, and adjust the voltage divider ratio (factor f) by a servo system or manually, until the meter M does not indicate any current. The ratio $e_2/e_1 = f$ can then be read off the voltage divider. A system of this kind is described by A. A. Gerlach and D. H. Pickens, *Electronics* 25, p. 145 (May 1952). The accuracy is better than 1 percent.

Resistive voltage dividers are usually correct within 0.1 percent. A high precision system using resistors to be controlled in steps by relays is described by E. A. Goldberg, *Electronics* 24, 121 (August 1951). The accuracy is ± 0.001 percent of the full scale, the speed of response is in the order of 1 sec. for full scale operation.

The multiplication by means of resistive voltage dividers as in Figure 2.7a is correct only when the output signal is fed into an impedance that is high compared with r . If this is not the case the resistance R should be

tapered so that the output voltage is proportional to the shaft rotation angle, regardless of the load current. Another way of overcoming this difficulty is in the use of a constant impedance attenuator (W. Shannon, *Electronics*, 19, 110-113, 1946, Aug.) An arrangement whereby the exact voltage divider ratio can be measured with a Wheatstone bridge is described by C. E. Berry et al, *J. Appl. Physics*, 17, 265, 1946, #4.

Voltage dividers can also be built with inductive and capacitive means. The standard inductive voltage divider (Variac) has an accuracy of only several percent. Special constructions permit accuracies up to 0.1 percent. (J. Lentz and I. A. Greenwood, Jr., *Rad. Lab. Ser. Vol. 21, Electronic Instruments*, p. 49.) The use of synchros with an output proportional to the shaft rotation is also described. Besides being controlled by mechanical means, voltage dividers can also be controlled by purely electrical means. For instance the element A or B in Figure 2.7b may be replaced by a tube with controlled plate resistance, or by a variable impedance. Multipliers based on this method are likely to be unstable and of low accuracy.

D. Amplifier with Variable Gain

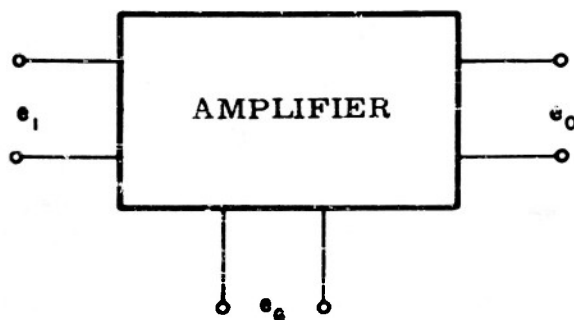

Figure 2.8

The output voltage e_o from an amplifier in Figure 2.8 is proportional to the input voltage and to the gain A of the amplifier

$$e_o = A \cdot e_i.$$

The gain, in turn, can be varied by the application of a gain control voltage e_G . In general the gain is not proportional to e_G but is proportional to a function $f(e_G)$. The variable gain amplifier is, therefore, an imperfect multiplier which can be made to a perfect multiplier by the use of a servo system (see Sec. 2.21).

E. Vibrating Capacitor Multiplier

If a parallel plate capacitor is connected in a circuit as in Figure 2.9 and if one plate of the capacitor is vibrated about a zero position so that

$$d = d_0 + d_1 \cdot \sin \omega t,$$

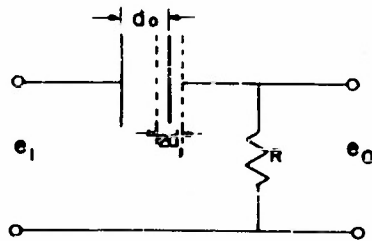

Fig. 2.9

it can be shown that the output voltage, for $d_1 \ll d_0$ and for $\omega C_0 R \ll 1$, is

$$e_0 = e_1 \cdot \omega C_0 R \cdot \frac{d_1}{d_0} \cos \omega t$$

where C_0 is the capacitance for $d = d_0$. This relation forms the basis of a precision analogue multiplier; e_1 is proportional to one signal, and d_1 is made proportional to the other. A measurement of e_0 then gives the product. An application of this multiplier in a feedback servo system is treated with 2.12A, below.

2.12 Servo Systems for Multiplication

No single element acts as a perfect multiplier, i.e. furnishes an output voltage of the form

$$e_o = k \cdot e_1 \cdot e_2$$

over a large range of the input signal voltages e_1 and e_2 , however, a number of elements (imperfect multipliers) provide output signals of the form

$$e_o = k \cdot e_1 \cdot f(e_2)$$

where $f(e_2)$ is either a nonlinear though monotonic function of e_2 (e.g. a vacuum tube characteristic) or a variation of the transfer ratio of the element in response to e_2 (e.g. the gain of an amplifier controlled by a variation of e_2). Perfect multiplication with such elements can be accomplished through the use of servo feedback systems.

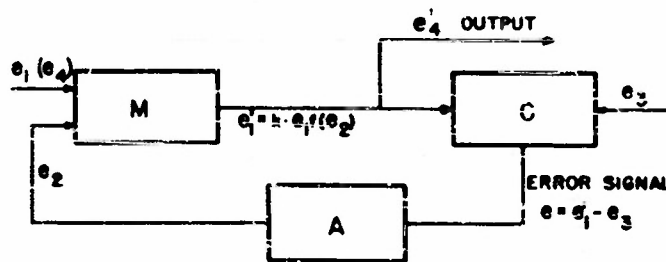

Figure 2.10

The generalized scheme of such a feedback system for multiplication and division is shown in Fig. 2.10. M is an imperfect multiplier or a servo controlled voltage divider or attenuator. A voltage e_1 (reference voltage) is applied to the input of M and emerges as a signal of the form

$$e_1' = k \cdot e_1 \cdot f(e_2) \quad (1)$$

which is fed into a comparator. The output from the comparator (error signal $e = e_1' - e_3 = k \cdot e_1 \cdot f(e_2) - e_3$) is fed back, via an amplifier A , into the multiplier M . If the gain of the amplifier is very large, the system will come to equilibrium when the error signal approaches zero, so that

$$k \cdot e_1 \cdot f(e_2) - e_3 = 0, \quad (2)$$

or

$$k \cdot f(e_2) = \frac{e_3}{e_1}. \quad (3)$$

If now another signal e_4 is applied to M and if its effect on the feedback loop is separated from that of e_1 (so that the voltage feedback to M is still e_2) then the output of M is

$$e_4' = k \cdot e_4 \cdot f(e_2). \quad (4)$$

From Eqs. (3) and (4) it follows that

$$\text{output } e_4' = e_4 \cdot \frac{e_3}{e_1}.$$

Means must be provided to separate the signal voltage e_4' from the reference voltage output e_1' . Three methods are available for this purpose.

A. Duplicate System Feedback Multiplier

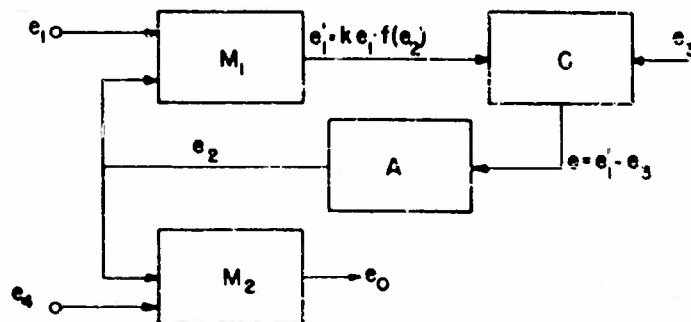

Figure 2.11

The system shown in Figure 2.11 requires two identical imperfect multipliers M_1 and M_2 (such as amplifiers with controllable gain or attenuators with controllable attenuation factor). One signal e_1 is fed into M_1 and emerges as

$$e_1' = k \cdot e_1 \cdot f(e_2).$$

This output e_1' and another signal e_3 are fed into a comparator. The output from the comparator (error signal) $e = e_1' - e_3$ is fed back via the high-gain amplifier A into the two multipliers M_1 and M_2 , thus setting the gains of these units. The system comes to equilibrium when the error signal becomes zero, i.e. when

$$e_1' = k \cdot e_1 \cdot f(e_2) - e_3$$

or

$$k \cdot f(e_2) = \frac{e_3}{e_1}.$$

If a signal e_4 is applied to the multiplier M_2 , its output will be

$$e_o = e_4 \cdot k \cdot f(e_2) = e_4 \cdot \frac{e_3}{e_1}.$$

Ref. See Korn and Korn, *Electronic Analogue Computers*, p. 220 and "Electronic Instruments," *Rad. Lab. Ser.*, Vol. 21, p. 50. Also N. L. Fritz, *Rev. Sc. Inst.*, 23, 667 (1952) #12. An example of a duplicate system feedback multiplier, using a vibrating reed capacitor system as described under 2.11 E, above, is shown in Figure 2.12.

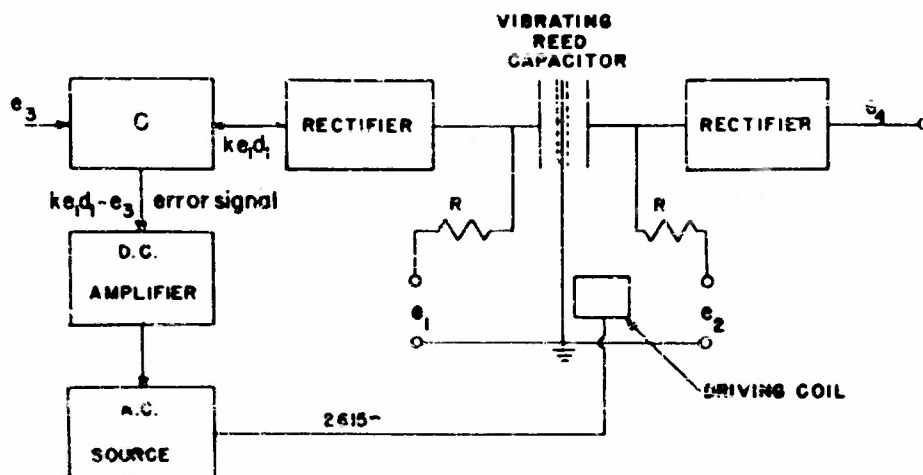

Figure 2.12

The voltages e_1 , e_2 , e_3 are applied as shown. The AC source oscillates the reed at an amplitude d_1 . The output from the vibrating capacitor of separation d is $k_1 e_1 d_1$. This is rectified and fed to the comparator C. The error signal is $k_1 e_1 d_1 - e_3$. This error signal is amplified and adjusts the output of the AC source. This feedback system, if the gain of the amplified system is sufficiently high, will make the error signal approach zero, or

$$k_1 e_1 d_1 - e_3 = 0.$$

The output from the other capacitor is

$$e_1 = \frac{K_2}{K_1} \frac{e_3 e_2}{e_i}.$$

The device can be used for multiplication or division. As a multiplier, it has accuracies $\sim 0.1\%$, but the attainment of this accuracy requires great care and precision in the construction. Operation in two quadrants is possible.

Ref. J. Lentz and I. A. Greenwood, Jr., M.I.T. Rad. Lab. Series, Vol. 21, Electronic Instruments, Sec. 3-10, p. 44 and 57, and Korn & Korn, p. 224.

B. Frequency Selection Method

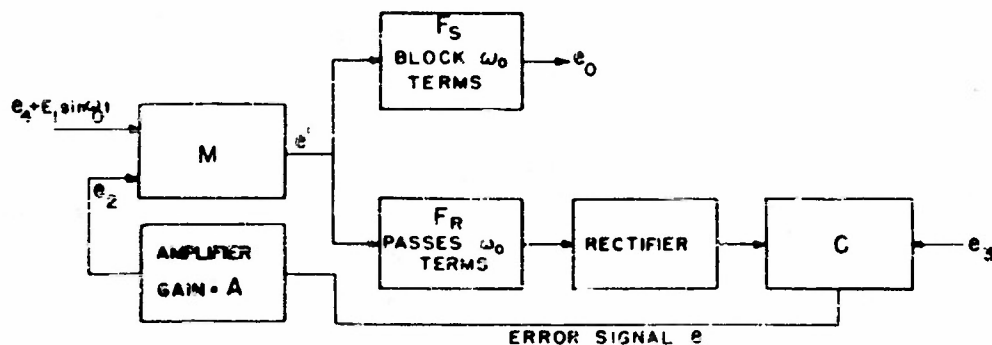

Figure 2.13

The input to the imperfect multiplier (Figure 2.13) is composed of an AC reference voltage $E_1 \cdot \sin \omega_0 t$ plus a variable DC signal voltage e_4 . The output from the multiplier is

$$e' = k \cdot E_1 \cdot \sin \omega_0 t \cdot f(e_2) + k \cdot e_4 \cdot f(e_2).$$

These two components are separated by two sets of filters F_R and F_S . Filter F_R only passes the first (AC) component which acts as a "reference" or "gain setting" component. The output is rectified and fed into a comparator. Another signal e_3 is also fed into the comparator. The output from the comparator is the error signal e which is amplified and fed into the multiplier. The system comes to equilibrium when

$$k_1 \cdot E_1 \cdot f(e_2) = e_3,$$

or

$$f(e_2) = \frac{E_1}{K' \cdot e_3}.$$

The signal component e_4 passes the multiplier and emerges as

$$e_4' = k \cdot e_4 \cdot f(e_2) = K'' \cdot \frac{e_4 \cdot E_1}{e_3}.$$

The frequency of the reference signal must be sufficiently different from that of the signal voltage e_4 so that the two components may be separated by the two filters.

References: "Waveforms" M.I.T. Rad. Lab. Series, Vo. 19, p. 674 and Korn and Korn "Electronic Analogue Computers," p. 229.

C. Time Sharing Method.

The voltages e_1 and e_4 in Figure 2.14 are applied alternatively to the imperfect multiplier M by means of a vibrating switch. A synchronous

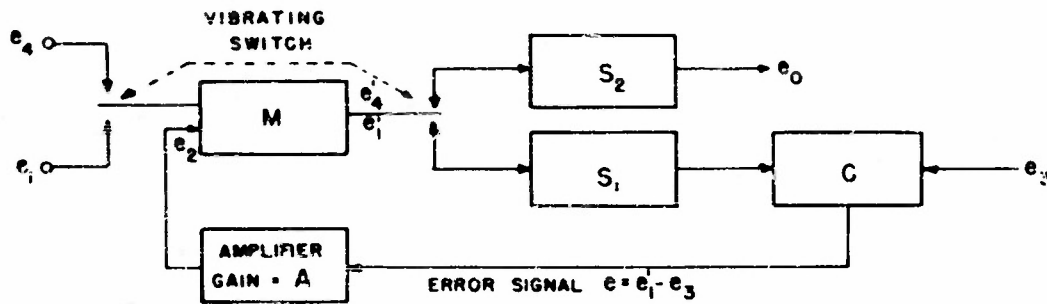

Figure 2.14

vibrator applies the output to the feedback loop S_1 -C-A-M when e_1 is applied and to the smoothing circuit S_2 , when e_4 is applied. Time constant circuits in the smoothing circuit S_1 keep the feedback conditions constant as if e_1 were applied all the time. The feedback system adjusts itself to equilibrium so that the error signal approaches zero, and e_2 does not vary with time, thus fixing the operating point of the multiplier. Although e_4 is applied intermittently, the smoothing circuit S_2 gives a steady output,

$$e_0 = \frac{e_4 e_3}{e_1}.$$

Ref. Korn and Korn, *Electronic Analog Computers*, p. 228.

2.2 Amplitude and Frequency Modulation System as Analog Multiplier

In the following method one input signal is used for frequency modulation of an oscillator. The resulting carrier is amplitude modulated by the other signal. This wave is fed into a discriminator of the Foster-Seeley type, which furnishes an output proportional to both amplitude and frequency deviation of the input signal.

A block diagram of the system is shown in Figure 2.15. Linear frequency and amplitude modulators are used to produce a signal with frequency deviation proportional to one input signal and amplitude deviation proportional to the second input signal. The reference signal for the discriminator is derived from the output of the frequency modulator so that

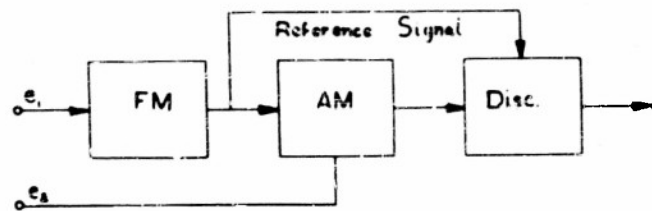

Figure 2.15

the sense of the output signal is preserved as e_2 passes through zero. This makes the device capable of operation in all four quadrants.

One of the advantages of this multiplier is that the modulators act on different characteristics of the signal - the amplitude and the frequency. Thus it is possible by means of feedback methods, to insure stability and accuracy of each modulator. The characteristics of the resulting modulator are determined ultimately by the stability and accuracy of the discriminator. Another advantage is that nowhere in the multiplier, except in the output, is the range of the multiplier limited.

R. Price (Technical Report #213, M.I.T. Res. Lab. of Electronics) describes an FM-AM multiplier of high accuracy with a dynamic range of 2500:1.

2.3 Pulse Methods for Analog Multiplication

2.31 Electronic Switch Modulators

The average value of a rectangular pulse signal as shown in Figure 2.16 is $E_{av.} = e_1 \cdot \frac{t}{T}$.

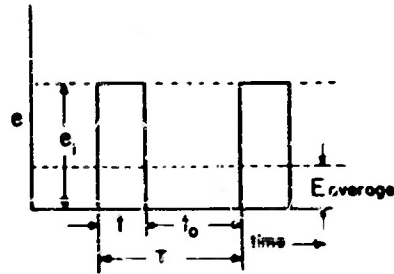

Figure 2.16

If e_1 is proportional to one input signal, and t is proportional to a second input signal e_2 , and if T is constant, then

$$E_{av.} = \frac{k}{T} (e_1 \cdot e_2)$$

and the device will serve as an analogue multiplier.

Several schemes have been proposed for maintaining t proportional to e_2 . Perhaps the most straightforward of these involves the feeding of a triangular waveform to a discriminator which will form a pulse of duration equal to the time the input waveform remains above a certain level. A diagram illustrating operation of such a system is shown in Figure 2.17.

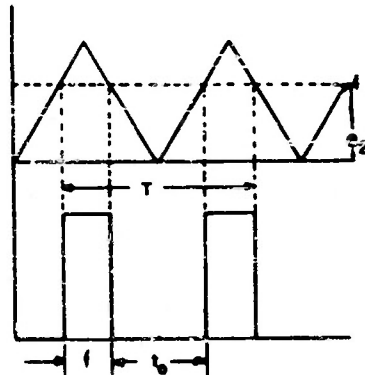

Figure 2.17

In general the production of a time interval proportional to e_2 will not be possible over a large range. A feedback multiplication and division system for three input signals based on the square wave pulse method (accuracy better than ± 0.2 per cent of maximum voltage, input signals with the ranges 23 to 57 volts, 46 to 230 volts, and 22 to 230 volts, and an output signal range of 5 to 165 volts) is described by J. Lentz and I. A. Greenwood, Jr. in *Electronic Instruments, Rad. Lab. Ser., Vol. 21, p. 50 ft. McGraw Hill, N.Y. 1949.*

See also E. A. Goldberg, *RCA Review* 13, 265, 1952 "High-Accuracy Time Division Multiplier" and "Waveforms" *MIT Rad. Lab. Series Vol. 19*, p. 674 and "Electronic Instruments" *MIT Rad. Lab. Series, Vol. 21, p. 50*, Korn & Korn, *Electronic Analog Computers*, p. 223.

2.32 Pulse Coincidence Methods

If several independent events occur with a random distribution in time with the probabilities $p_1, p_2, p_3 \dots$, then the probability of simultaneous occurrence of all of them is

$$P = p_1 \cdot p_2 \cdot p_3.$$

This result may be extended to periodic wave forms whose periods have no common divisor. In particular, if rectangular pulses of independent repetition frequencies are superimposed, the time during which all pulses are positive will be proportional to the product of the duty ratios t/T of the pulses.

A system which uses this principle for analog multiplication is shown schematically in Figure 2.18.

The elements P_1, P_2 , and P_3 produce rectangular pulses of a duty ratio t/T proportional to the applied input signals e_1, e_2 , and e_3 .* These

*Means to accomplish this to be described in the section on pulse generators. See also the preceding paragraph.

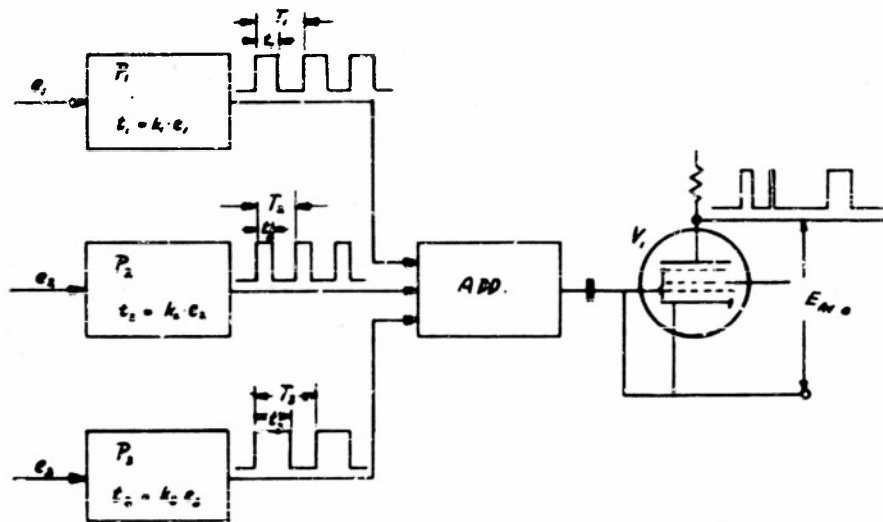

Figure 2.13

rectangular pulses are added by means of a resistance network (see this chapter, Section 1.12). The resulting voltage is applied to a tube V_1 which is biased in such a way that a plate current flows only when all three signals applied to the grid of this tube are positive. The average plate current in this tube is then proportional to the product of the input voltages.

Any number of input variables may be used with this method. The accuracy obtained is in the order of 4 per cent, limited primarily by the error in linear time modulation of the pulses. Using input signal of frequencies in the order of 20 kc, the time needed for a computation is indicated to be about 500 microseconds.

References: A. C. Hardy and E. C. Dench, J. O. S. A. 30, 308 (1948) "An Electronic Method of Solving Simultaneous Equations." See also "Waveforms" M.I.T. Rad. Lab. Series, Vol. 19, p. 676 and "Electronic Instruments" M.I.T. Rad. Lab. Series, Vol. 21, p. 59.

2.33 Time Selection Multiplier

A capacitor originally charged to a voltage e_0 is allowed to discharge through a resistor. The voltage appearing across its terminals at a time t is

$$e = e_0 \epsilon^{-\frac{t}{R \cdot C}}$$

This relation has been used as the basis of an analogue multiplier. The original voltage e_0 is made proportional to one input signal, and $\epsilon^{-\frac{t}{RC}}$ proportional to a second input signal. A block diagram of such a multiplier is shown in Figure 2.19.

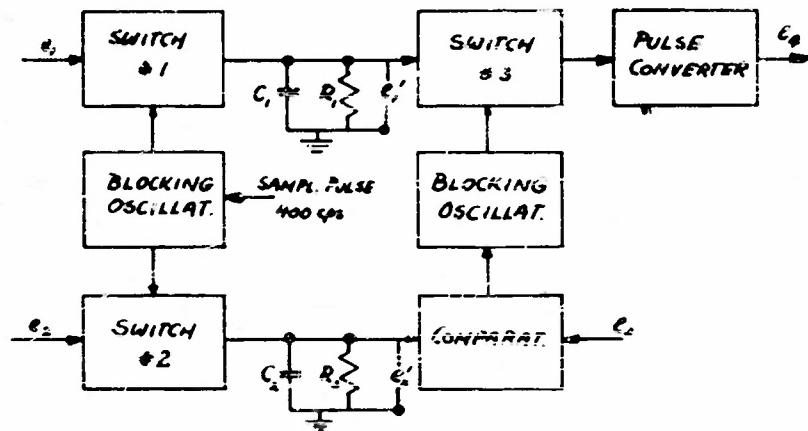

Figure 2.19

The circuit operates in the following manner:

1. Initially switches 1 and 2 in Figure 2.19 are closed, switch 3 is open. Signal e_1 charges C_1 to voltage e_1 , and signal e_2 charges C_2 to voltage e_2 .

2. Every $1/400$ of a second a pulse produced by the blocking oscillator 1 opens switches 1 and 2 simultaneously, and then the voltages across C_1 and C_2 decay exponentially with time.

3. When the voltage across C_2 is equal to e_3 , the comparator produces a pulse to trigger blocking oscillator 2, which briefly (5μ sec) closes switch 3. At this instant t_1

$$e'_1 = e_1 \epsilon^{-\frac{t_1}{R_1 C_1}} \quad (1)$$

and

$$e'_2 = e_2 \epsilon^{-\frac{t_1}{R_2 C_2}} = e_3. \quad (2)$$

4. Closing of switch 3 produces a pulse of a magnitude e'_1 at the input of the pulse converter (smoothing circuit) and a DC voltage $e_4 = k \cdot e'_1$ appears at its output.

Then, if $R_1 C_1 = R_2 C_2$ it follows from Equations (1) and (2) that

$$e_4 = k \cdot \frac{e_1 \cdot e_3}{e_2}.$$

The frequency of the input signals is restricted by the repetition frequency of the device. Since the attenuation of the networks is always positive, the method will operate in two quadrants only. For reference see T. Broomell and L. Riebman, Proc. IRE 40, (1952), p. 568, "Sampling Analogue Computer." The described multiplier has an accuracy of the order of 1 per cent and input ranges for e_1 , 0 to 12 volts; e_2 , 5 to 90 volts; e_3 , 2 to 85 volts. Signal e_3 must be less than e_2 .

2.4 Electron Beam Analog Multipliers

The following methods employ focussed electron beams, such as used in cathode ray tubes, for the solution of analog multiplication problems. The input and output signals are presented in the form of voltages.

2.41 Split-Target Cathode Ray Tube

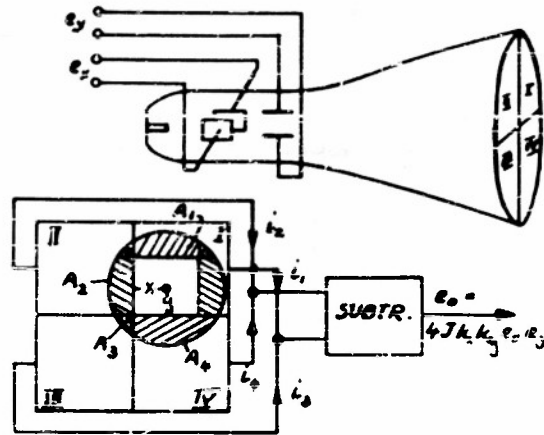

Figure 2.20

A cathode-ray tube (Figure 2.20) produces an electron beam of circular cross section and of uniform current density J which impinges upon a target split in four quadrants. Two voltages, e_x and e_y , deflect the electron beam. The current collected from each quadrant is proportional to the respective area covered by the beam. From simple geometric consideration it can be shown that the area $A_1 - A_2 - A_4 + A_3$ is equal to the area of the rectangle with the sides $2x$ and $2y$ and, therefore, proportional to the product $4(xy)$. Since $x = k_x e_x$ and $y = k_y e_y$, the output from the subtracting element in Figure 2.20 is

$$e_o = 4 \cdot a J k_x \cdot k_y \cdot (e_x - e_y).$$

The device is capable of operation in four quadrants. The accuracy is in the order of 2 per cent and is limited by the difficulties of obtaining an electron beam with uniform current density, by the deflection system, and by secondary emission from the target. A maximum total current output of

300 μ Å has been obtained. Operation is possible at frequencies as high as 70 kc. Direct division is not possible with the device. Reference, see M. J. Somerville, "Electronic Multiplier," *Electronic Eng.* 24, 78 (1952).

2.42 Crossed-Field Cathode-Ray Tube Multiplier

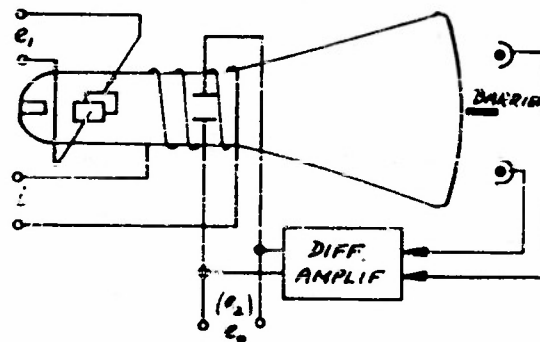

Figure 2.21

A cathode-ray tube (Figure 2.21) is provided with an axial coil in the vicinity of the second pair of deflection plates. The magnetic field of this coil, parallel to the axis of the tube, has no effect on the undeflected electron beam. If a voltage e_1 is applied to the first set of deflection plates (assumed to be horizontal) the beam will acquire a vertical velocity component v_z proportional to the magnitude of e_1 .

$$v_z = k_1 \cdot e_1.$$

When the beam enters the magnetic field, it will suffer a horizontal force F_m proportional to the strength of the magnetic field and the vertical component of velocity v_z , where

$$F_m = q \cdot v_z \cdot B.$$

This magnetic force causes a horizontal deflection of the beam. Any horizontal deflection of the beam is detected by the two photoelectric cells, which produce a voltage proportional to the amount of deviation. This voltage is amplified and applied to the second pair of deflection plates

in such a manner that the beam suffers an electrostatic force opposite in direction to the magnetic force. If the amplification is very large, the total horizontal deflection will be reduced to a very small value, so that

$$F_e = k_2 e_2 = -F_m.$$

Thus, $k_2 e_2 = -q k_1 e_1 B = -q k_1 e_1 k_3 i$, (assuming $B = k_3 i$.) or

$$e_2 = \frac{q k_1 k_3 e_1 i}{k_2}. \quad \text{Multiplication}$$

If the voltage e_2 is used as an input variable, and e_1 is supplied from the error signal from the photocells, then

$$e_1 = \frac{k_2}{q k_1 k_3} \frac{e_2}{i}. \quad \text{Division}$$

A difficulty with this multiplier is the problem of producing a rapidly varying magnetic field strictly proportional to the input voltage.

A device of this kind, which operates at frequencies up to 20 kc for e_1 , and up to 3 kc for i , is described by A. B. MacNee, Proc. IRE 37, 1315, (1949).

2.5 Output Transducer Analog Multipliers

The following methods of multiplication and division are based on the mechanical effects of output transducers, usually of the magnetic type. The input signals are supplied in the form of voltages or currents; the result appears either as the deflection of a meter (2.51 and 2.52) or as an output voltage (2.51A). Four-quadrant operation is possible with method 2.51 and 2.51A. Direct division is best accomplished with methods 2.51A and 2.52.

2.51 Electro-Dynamometer Analog Multiplier

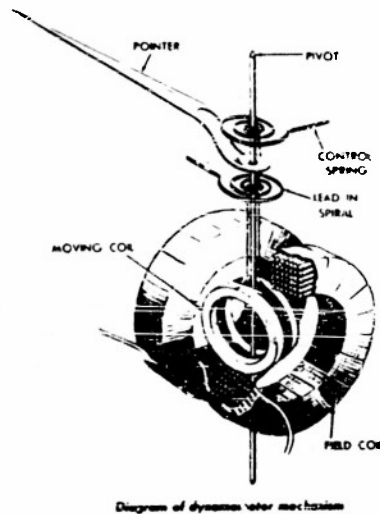

Figure 2.22

An electro-dynamometer* consists essentially of a moving coil in the field of an electromagnet, Figure 2.22. The torque tending to rotate the coil is proportional to the current i_1 , passing through the coil, and to the strength of the magnetic field, which in turn is proportional to the current i_2

*The exact description of the instrument will be given in the part on mechanical output transducers.

passing through the electromagnet. Thus, the instantaneous torque in the vicinity of the zero position of the moving coil, is $T = k \cdot i_1 \cdot i_2$.

The deflection of the moving coil is proportional to the torque and measures, therefore, the product of the instantaneous values of the currents i_1 and i_2 , provided that the natural frequency of the mechanical moving system is high enough to follow the torque. For higher frequency of the currents i_1 and i_2 , the deflection is proportional to the average torque. The natural frequency of such mechanical systems is, in general, in the order of 1 to 10 cps. Systems with natural frequencies up to 2500 cps have been built.

Errors may arise if the magnetic field of the moving coil and the electro magnet are not perpendicular to each other so that a variation of the magnetic field of one coil will produce a voltage in the other coil by electromagnetic induction. This error can be eliminated by: 1) by using high levels of input signals and by making the resistances of the circuits connected to each coil high so that the influence of the induced voltages becomes negligible, 2) by bringing the movable coil back into zero position by means of a torsion spring (and by reading the restoring torque) or by means of a servo system.

2.51A Electrodynamometer with Servo-System

A schematic diagram of this multiplier is shown in Figure 2.23.

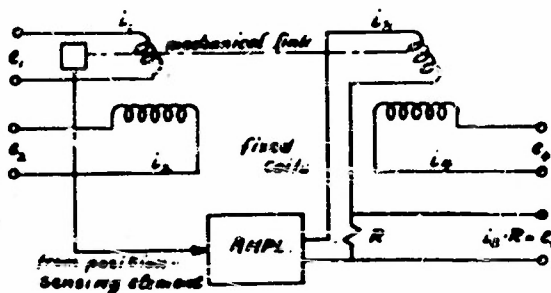

Figure 2.23

Two identical electrodynamicometers are mounted on the same shaft so that their torques counteract each other. The total torque on the shaft will be zero only if

$$i_1 \cdot i_2 = -i_3 \cdot i_4.$$

The current i_3 is derived from a pick-up device which furnishes a signal (error signal) whenever the common shaft deviates from the zero position. If the gain of the amplifier is very high, the current i_3 will be large enough to bring the system back to the zero position. In equilibrium (deviation = zero) the current is

$$i_3 = \frac{-i_1 i_2}{i_4}.$$

The frequency response of such a multiplier will be limited by the mechanical inertia of the moving coil-shaft assembly. Operation in four quadrants is possible with the device. Direct division may be performed by applying the input signal at i_4 .

References: R. N. Varney, RSI 13 10 (1942), "An All-Electric Integrator for Solving Differential Equations," and "Electronic Instruments," M.I.T. Rad. Lab. Series, Vol. 21, p. 57, Korn and Korn, p. 217, "Electronic Analog Computers."

2.52 The Ratio Meter

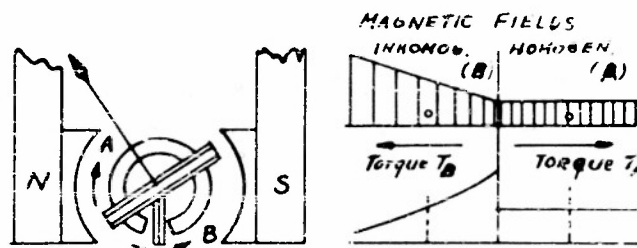

Figure 2.24

The instrument* consists of two measuring systems A and B in Figure 24 (e.g. moving coil systems) on one axis. None of the systems has a mechanical restoring force. At least one system (B) moves in an inhomogeneous magnetic field so that its torque T_B increases with increased angle of rotation ϕ ; this system acts as an "electric spring," therefore, and its restoring force is

$$T_B = k_1 \cdot i_1 \cdot \phi.$$

If the other coil moves in a homogeneous magnetic field, its ϕ torque is

$$- T_A = k_2 \cdot i_2.$$

The entire system comes to equilibrium when both torques are equal ($T_B = T_A$).

Then

$$k_1 \cdot i_1 \cdot \phi = k_2 \cdot i_2,$$

$$k_1/k_2 \cdot \phi = i_2/i_1,$$

i.e. the deflection is proportional to the ratio of both currents, independent of the absolute magnitude of the currents.

*Exact description in the chapter on mechanical output transducers.

2.6 Logarithmic Methods

Multiplication by logarithmic methods depends on the relation

$$\log x + \log y + \log z = \log (xyz).$$

Division can be effected by the subtraction of logarithms:

$$\log x + \log y - \log z = \log \frac{xy}{z}.$$

Since $\log x$ is undefined for negative values of x , multiplication or division based on logarithmic methods is essentially a one-quadrant operation.

In order that the results of a computation using logarithmic devices appear in a useful form, it is necessary to take the antilogarithm of the output of the device.

Practical Methods of Logarithmic Multiplication and Division

A schematic diagram of a logarithmic multiplier or divider is shown in Figure 2.25.

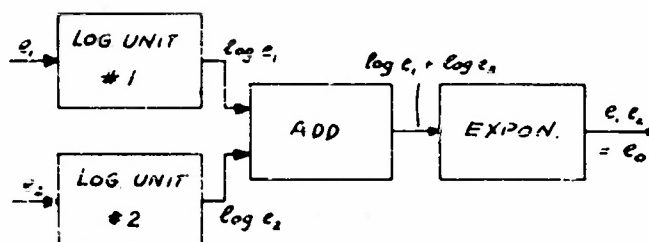

Figure 2.25

If a subtracting rather than an adding element is used, division may be performed.

In general the situation is not as simple as this, and the units used will have the following characteristics.

Logarithmic Unit No. 1 - output = $K_1 + K_2 \log_{10} e_1$

Logarithmic Unit No. 2 - output = $K_3 + K_4 \log_{10} e_2$

Exponential Unit - output = $K_5 (K_6)$ input.

In this case the output of the device will be

$$\text{Output} = K_5 (K_6)^{(K_1+K_3)} + K_2 \log_{10} e_1 + K_4 \log_{10} e_2$$

or

$$\text{Output} = K_5 (K_6)^{(K_1+K_3)} (e_1)^{K_2 \log_{10} K_6} (e_2)^{K_4 \log_{10} K_6}$$

which is of the form $\text{Output} = K (e_1)^a (e_2)^b$.

in order that $a = b = 1$, it must be arranged that

$$K_2 \log_{10} (K_6) = K_4 \log_{10} (K_6) = 1.$$

Then

$$\text{Output} = (K_5)(K_6)^{(K_1+K_3)} (e_1 e_2) = K \cdot e_1 \cdot e_2.$$

However, it will be found that the output range of the device will be limited to a value considerably smaller than that expected from the characteristics of the output network, due to the change of scale represented by the constant K .

A more satisfactory way of using logarithmic devices for multiplication and division, which permits realization of maximum output range is shown in Figure 2.26.

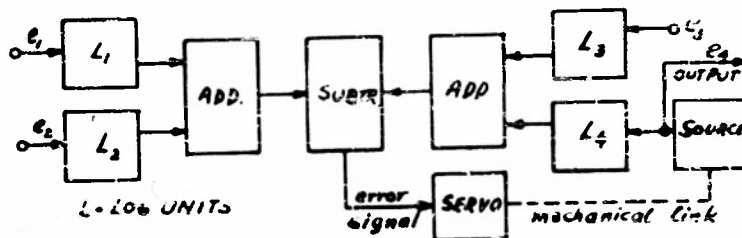

Figure 2.26

The inputs e_1 , e_2 , and e_3 are fed into the logarithmic elements L_1 , L_2 , L_3 , while an adjustable source feeds a signal e_4 into L_4 . The signal e_4

also represents the output signal. The logarithmic elements have the identical characteristics

$$e_{\text{out}} = K_1 + K_2 \log e_{\text{in}}.$$

The outputs from the logarithmic elements is added and led to the comparator (subtractor). One input to this comparator is then

$$e_7 = e_5 + e_6$$

the other is

$$e_8 = e_9 + e_{10}.$$

The servo system adjusts e_4 so that the error signal becomes zero, i.e. so that

$$e_7 - e_8 = 0$$

from which follows that

$$e_4 = \frac{e_1 \cdot e_2}{e_3}.$$

The device may be used for simultaneous multiplication and division.

The output range will be limited by range of the logarithmic devices used and by the product of the ranges of e_1 , e_2 , and e_3 . The speed of the device will be limited by the servo system.

2.7 Multiplication by Square Law Methods

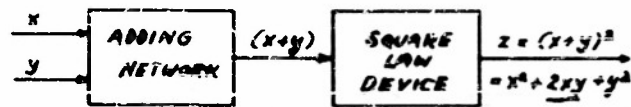

Figure 2.27

The basic diagram of a multiplier method using square law devices is shown in Figure 2.27. Two signals, x and y , are added and their sum applied to a square law device,* i.e., a device of the type

$$\text{output} = k_0 + k_1 (\text{input})^2. \quad (1)$$

(Some square law devices will have a characteristic of the form

$$\text{output} = k_0 + k_1 (\text{input}) + k_2 (\text{input})^2. \quad (2)$$

With $(x + y)$ applied to the input, the output is

$$z = k_0 + k_1 (x^2 + 2xy + y^2),$$

i.e. it contains the desired component, $2xy$, which must be separated from the total output. There are two ways in which this isolation may be performed.

1. The undesired terms may be cancelled by the use of other square law circuits (2.71):

$$(x + y)^2 - y^2 = x^2 + 2xy,$$

or

$$(x + y)^2 - (x - y)^2 = 4xy.$$

2. If the signals are supplied in the form of, or can be converted into amplitude amplitude modulated AC signals, the desired component may be isolated by frequency selection (2.72).

*Square law devices to be described in "non-linear circuit elements."

2.71 Isolation of the Product by Cancellation of the Undesired Terms

A. Multipliers with Two Square Law Units (Figure 2.28).

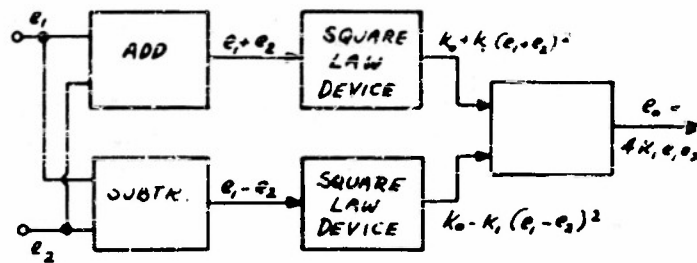

Figure 2.28

The signals e_1 and e_2 are added in one unit, and subtracted in another unit. Their sum ($e_1 + e_2$) and their difference ($e_1 - e_2$) are applied to two identical square law devices. The difference between the two outputs is

$$K_1 \left[(e_1 + e_2)^2 - (e_1 - e_2)^2 \right] = 4k_1 \cdot e_1 \cdot e_2.$$

The amplitude and frequency range of the device is limited only by the square law device. A linear term of the characteristics of the square law devices, such as indicated in Eq. (2) above, introduces an error of the amount

$$2 \cdot k_1 \cdot e_2.$$

An example of a practical circuit for the formation of the sum and the difference of the signals e_1 and e_2 is shown in Figure 2.29. An example of a multiplying circuit is shown in Figure 2.30. (This circuit uses a heated thermocouple as a square law device; the thermo EMF is proportional to the square of the heating current.)

B. Multipliers with One Square Law Device Alternatively Used in Two Circuits

The circuit shown in Figure 2.31 avoids the necessity for two identical square law elements by applying one square law device alternatively in the sum and difference forming circuits

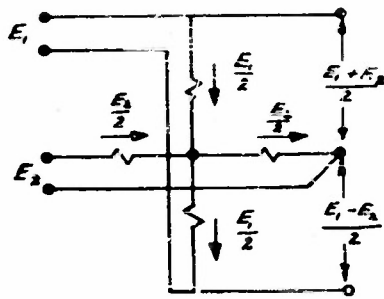

Figure 2.29

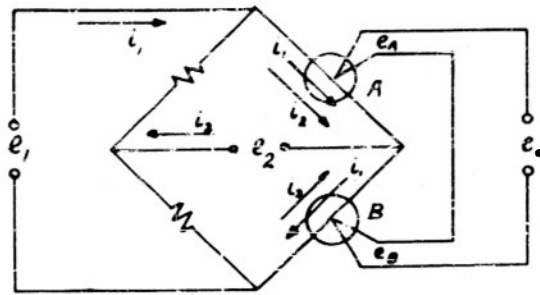

Figure 2.30

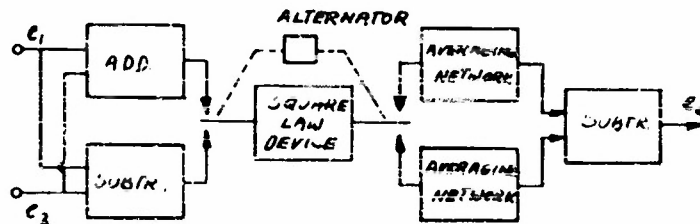

Figure 2.31

The method is applicable only if the frequency of the input signals is much lower than the switching rate of the alternator.

An alternative method is shown in Figure 2.32.

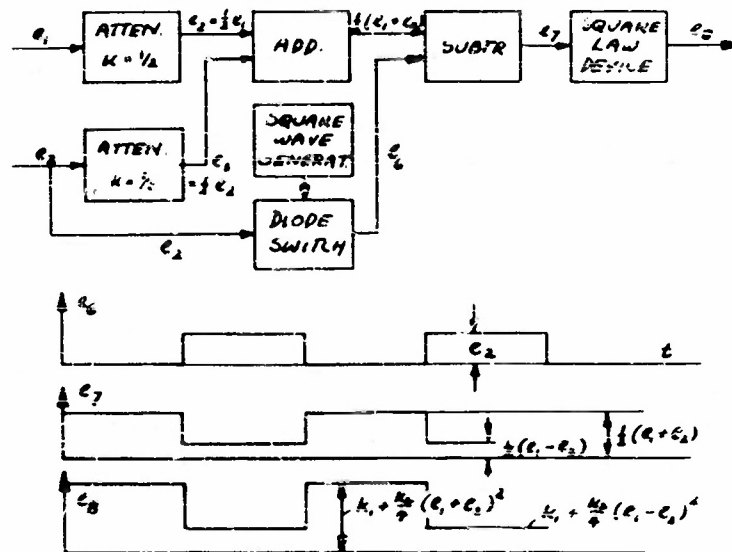

Figure 2.32

The two input signals e_1 and e_2 are attenuated by $1/2$, added, and applied to one terminal of the subtractor. At the same time signal e_2 is passed through a diode switch which, controlled by the square-wave generator, conducts only half the time. The output wave form e_6 in Figure 2.32 varies between zero and e_2 . When $e_6 = 0$, the subtractor has an output voltage $e_7 = \frac{1}{2}(e_1 + e_2)$, and when $e_6 = e_2$, the subtractor has an output equal $\frac{1}{2}(e_1 + e_2) - e_2 = \frac{1}{2}(e_1 - e_2)$. If the output e_7 is applied to the square law unit having a characteristic

$$e_o = k_1 + k_2 (e_{in})^2$$

then the alternating or square wave component in the output from this unit will be

$$e_8 = k_2 \cdot e_1 \cdot e_2$$

(Ref., see Chance, Williams, Yang, Busser and Higgins, R.S.I. 22, (1951), p. 683. The square law element is synthesized from 15 biased diodes, the circuit has a delay of less than 40μ sec. and an accuracy of better than ± 1 per cent).

2.72 Square Law Devices Using Frequency Selection Methods

A. The following methods can be applied if one input e_1 is presented in the form of, or can be converted into, an amplitude modulated AC signal, and the other input e_2 is presented as a DC signal.

1. Method with a single square law unit.

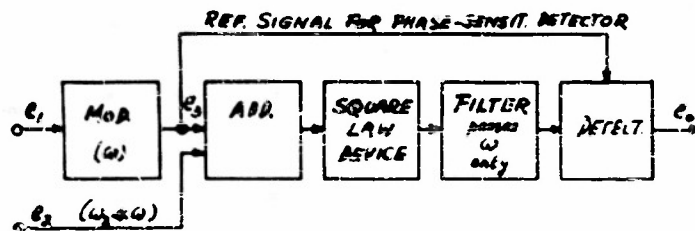

Figure 2.33

A block diagram of the circuit is shown in Figure 2.33. One signal, e_1 , is applied to a modulator and emerges in the form $e_3 = k_1 \cdot e_1 \cdot \sin \omega t$. The other signal e_2 is added to e_3 and the sum is fed into the square law device. The output from this device contains a component of the form

$$2 \cdot k_1 \cdot k_3 \cdot e_1 \cdot e_2 \cdot \sin \omega t.$$

This is the only component containing $\sin \omega t$, which is filtered out and detected. If a phase sensitive detector is used the setup is capable of operation in four quadrants. The operation of the system is limited to square law devices that follow Eq. (1) on p. 55. Devices with a characteristic of Eq. (2) p. 55, introduce considerable errors.

2. Method with two identical square law units.

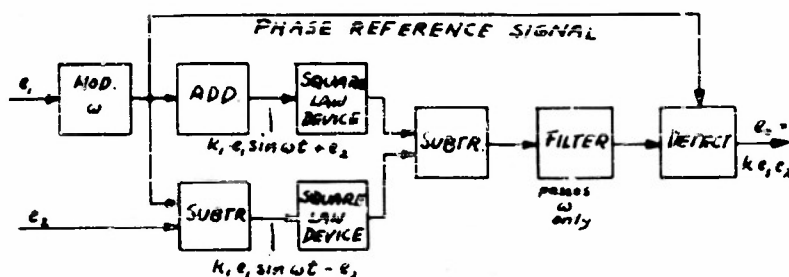

Figure 2.34

The operation of the multiplier can be improved if two identical square law devices are available. Figure 2.34 shows a block diagram of such a multiplier. One signal, e_1 , is applied to an amplitude modulator and emerges in the form $e_3 = k_1 \cdot e_1 \sin \omega t$. Together with a second input signal, e_2 , the sum ($e_2 + k_1 \cdot e_1 \cdot \sin \omega t$) and the difference ($e_2 - k_1 \cdot e_1 \cdot \sin \omega t$) is formed and applied to the identical square law devices. The outputs from these devices, after subtraction, furnish a term $4 k_1 \cdot k_4 \cdot e_1 \cdot e_2 \cdot \sin \omega t$ which passes through the filter and emerges from the detector in the form $e_0 = k_1 \cdot e_1 \cdot e_2$. The multiplier will operate in four quadrants if phase sensitive detection is used.

A practical circuit of such a multiplier is shown in Figure 2.35

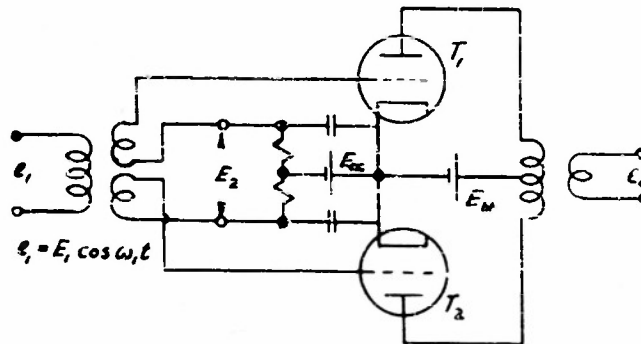

Figure 2.35

The tubes T_1 and T_2 operate in the curved part of their characteristics so that the plate current is

$$i_p = k_0 + k_1 \cdot e_g - k_2 (e_g)^2.$$

The circuit requires close matching of the tube characteristics.

B. The following method can be applied if both input signals are presented in the form of amplitude modulated AC signals.

1. Method with a single square law unit (Figure 2.36).

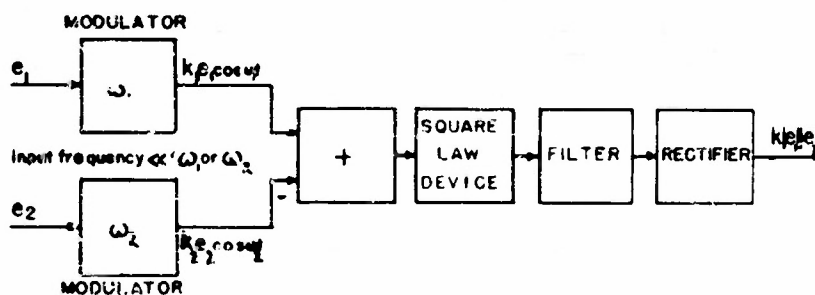

Figure 2.36

The input signals e_1 and e_2 modulate the amplitude of the two oscillators of fixed frequencies, ω_1 and ω_2 . The outputs $k_1 e_1 \cos \omega_1 t$ and $k_2 e_2 \cos \omega_2 t$ are added, and the sum is applied to the square law device which gives an output

$$e' = k_3 + k_4 e + k_5 e^2.$$

The last term has a component $k_1 k_2 e_1 e_2 \cos(\omega_2 - \omega_1)t$, which is filtered and rectified. The output of the rectifier is then proportional to $k_1 k_2 e_1 e_2$.

The maximum frequency of the input signals must be much less than the carrier frequency and also the difference in carrier frequencies. The output of the multiplier is independent of the sign of the input signals and thus is capable of operation in only one quadrant.

2. Method with two identical square law devices.

The circuit on p. 59 is capable of operation also when e_1 and e_2 are presented in the form of amplitude modulated AC signals.

An example of such a multiplier is shown in Fig. 2.37. (Applied Electronics, M.I.T. Dept. E.E. Staff, John Wiley, N.Y., p. 688). The vacuum tubes are operated in the square part of their characteristics, i.e. so that the plate current

$$i_p = k_0 + k_1 (e_g) + k_2 (e_g)^2.$$

if

$$e_1 = E_1 \cos \omega_m t$$

and

$$e_2 = E_2 \cos \omega_c t$$

then the input for one tube will be $(e_1 - e_2)$ and for the other $(e_1 + e_2)$ and the output will contain a term of the form $k \cdot E_1 \cdot E_2 [\cos(\omega_c + \omega_m)t + \cos(\omega_c - \omega_m)t]$ which may be isolated by a filter which passes either the frequency $(\omega_c - \omega_m)$ or the frequency $(\omega_c + \omega_m)$.

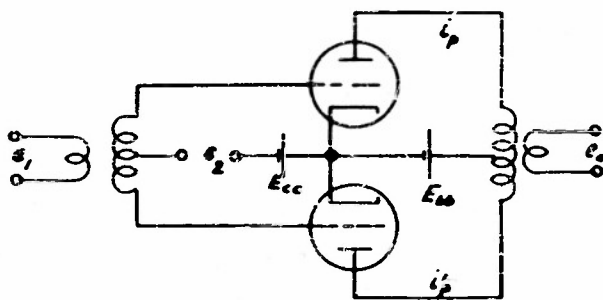

Figure 2.37

(Ref., McGann - al. Proc. IRE 37, 954 (1949).)

2.8 Multiplication of Resistance (Impedance) Settings

The following method can be used for analog multiplication if the input signals are presented in the form of impedances or resistances. The output representing the result in either a resistance or the position of a meter.

2.81 The Wheatstone bridge as Analog Multiplier

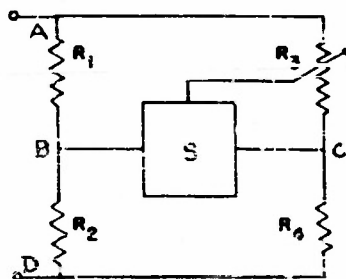

Figure 2.38

The resistances R_1 , R_2 , and R_3 are adjusted in accordance with the input signal or represent these signals themselves. R_3 is varied, either manually or by means of a servo system, until the current in the diagonals BC is zero, so that

$$R_3 = \frac{R_1 \cdot R_4}{R_2}$$

2.82 Through Addition of Resistances on a Logarithmic Scale (Slide rule analogs)

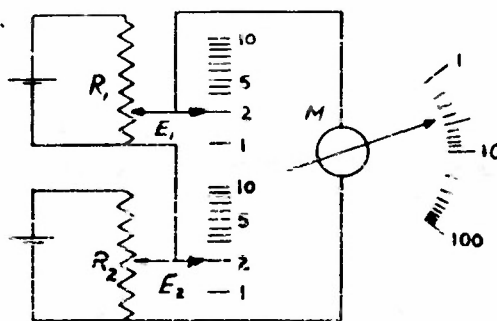

Figure 2.39

The adjustable resistance R_1 and R_2 are connected as shown in Figure 2.39, so that the voltages E_1 and E_2 vary linearly with the resistance. The setting of the resistance is then read on a logarithmic scale. (Only the scale has a logarithmic character, the resistances are linear, i.e., their resistance value increases linearly with the angle of rotation.) The system M measures the sum of the voltages $E_1 + E_2$ and has also a linear character, i.e. its deflection is proportional to the applied voltage. However, the deflection is read on a logarithmic scale. Since

$$\log M = \log E_1 + \log E_2, \quad M = E_1 \cdot E_2,$$

the reading on the scale of M indicates the product of the resistance settings.

Any one of the systems for addition and subtraction of voltages (Sec. 1) may be used for multiplication and division, provided that the input and output signals can be read on appropriate logarithmic scales.

The logarithmic character of the scales makes it possible to perform a number of different computing operations. If both potentiometer scales run in opposite direction, the meter will indicate the ratio of both values set. (Since $a/b = c$, $\log a - \log b = \log c$.) If one scale is divided twice or half as widely spaced than the others, the meter will indicate the product $c = a \cdot b^2$ or $c = a \cdot b$ (since $\log a + 2 \cdot \log b = \log c$, or $\log a + \frac{1}{2} \log b = \log c$). All these methods require a manual or mechanical adjustment of the resistances.

3. DIFFERENTIATION

3.0 General Considerations

3.1 Capacitive Differentiators

3.11 Simple R-C circuits

3.12 Feedback R-C differentiators

3.2 Inductive Differentiators

3.21 R-L circuits

3.22 Transformer differentiators

3.23 Feedback inductive differentiator

3.3 LCR-Differentiators

3.4 Transducer Differentiators

3. Differentiation

3.0 General considerations

The general form of a differentiator is shown in Figure 3.1



Figure 3.1

The input signal e_i varies with time as $e_i = f(t)$. The output signal is, at any instant, proportional to the time derivative,

$$e_o = k \frac{de_i}{dt} .$$

The differentiators described in this section perform differentiation only with respect to time. If it is desired to obtain the derivative of a function with respect to a variable other than time, the method shown in Figure 3.2 may be used, which is based on the relationship

$$\frac{dy}{dx} = \frac{dy/dt}{dx/dt}$$

provided that a variation of x and y with time can be obtained.

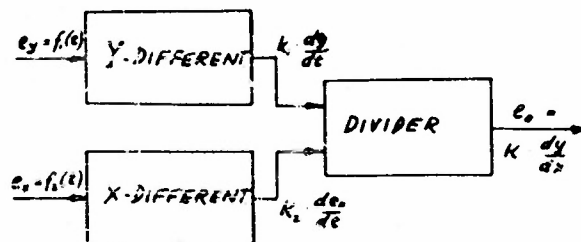

Figure 3.2

There are four principal methods of performing differentiations by electrical means; 1. by using a resistance - capacitance (RC) network (Sec. 3.1), 2. by the use of inductances or transformers (RL-networks, Sec. 3.2); 3. by employing a network containing capacitance inductance

and resistance (CLR-network, Sec. 3.3), and 4. by means of transducers (Sec. 3.4). Capacitance methods are simple and accurate and most frequently applied. Inductance methods are handicapped by errors introduced by the unavoidable resistance associated with any practical inductor, but have certain advantages at high frequencies. The use of the CLR circuit and of transducers for the purpose of differentiation is limited to special cases.

Differentiators, by their very nature, have a preferred high frequency response; their use may lead to instability and to an increase of the noise level because of the high frequency components of noise voltages. In certain cases (e.g. in differential analyzers) the functions of a differentiator may be performed by implicit operation using integration. Such methods of eliminating the need for a differentiator should be investigated in cases where accuracy and stability are essential.

3.1 Capacitive Differentiation

3.1.1 Simple RC Differentiator



Figure 3.3

If a variable voltage e_i is applied to a capacitor C in Figure 3.3, the current in the circuit is

$$i = C \frac{de_i}{dt} \quad (1)$$

i.e. the current is proportional to the time derivative of the input voltage.

Usually a voltage rather than a current output is desired. A voltage proportional to the current i may be obtained by inserting a resistance R in series with the capacitor, as shown in Figure 3.4.

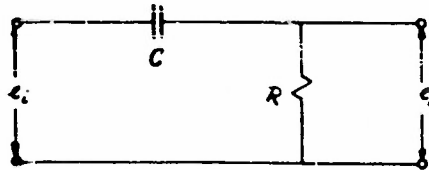

Figure 3.4

If the voltage across the resistance R is small compared to the voltage across C (or to the voltage e_i), i.e. if

$$e_o \ll e_c \text{ or } e_o \ll e_i \quad (2a)$$

or, if the resistance R is small compared to the impedance of C_1 e.g. for a sinusoidal input signal of radian frequency $\omega = 2\pi f$, if

$$R \ll \frac{1}{\omega C}, \text{ or } \omega RC \ll 1 \quad (2b)$$

or, if the time constant $T_o = R \cdot C$ of the circuit is small compared with the time of change T of the signal

$$T_o \ll T \quad (2c)$$

then the output signal is

$$e_o = R \cdot i = RC \frac{de_i}{dt} \quad (3)$$

If $R \cdot C$ is small, the differentiation is nearly correct, but the output e_o is small. Increase of $R \cdot C$ increases the output but causes a departure from the correct value of the differentiation.

Errors in capacitive differentiators

A. General

Inherent errors.

The insertion of a resistor R in the circuit of Figure 3.4 changes Equation (1) into

$$i = C \frac{d(e_i - e_o)}{dt} = C \frac{de_i}{dt} - C \frac{de_o}{dt}.$$

Since $e_o = i \cdot R$, the output from the differentiator becomes

$$e_o = RC \frac{de_i}{dt} - RC \frac{de_o}{dt} \quad (4)$$

The output of a perfect differentiator would be

$$e_o' = RC \cdot \frac{de_i}{dt} \quad (5)$$

Thus the error of the RC differentiator is

$$\epsilon = -R \cdot C \frac{de_o}{dt} \quad (6)$$

However, if the error is small, the output signal may be approximated by Equation (5), and in this case the error will be approximately

$$\epsilon \approx -R^2 C^2 \frac{d^2 e_i}{dt^2} \quad (7)$$

and the fractional error will be

$$\frac{e}{e_c} \approx -R \cdot C \frac{d^2 e_i}{dt^2} / \frac{de_i}{dt} \quad (8)$$

If the output impedance of the source, R_s , and the input impedance of the stage following the differentiator, R_L , have to be taken into account, the output signal (across R_L) is

$$e_o = \frac{R \cdot R_L}{R + R_L} \cdot C \cdot \frac{de_i}{dt} - \left(\frac{R \cdot R_L}{R + R_L} + R_s \right) \cdot C \cdot \frac{de_o}{dt} \quad (9)$$

Practical errors

For correct differentiation a capacitor of negligible leakage resistance R_C must be used, since otherwise an error term $e_i \cdot \frac{R}{R + R_C}$ appears at the output terminals. The capacitor should also be free of residue formation ("soaking" or "absorption" effect*), and where operation over a wide temperature range is required, the capacitance must be independent of temperature. Capacitors with polystyrene dielectric are recommended.

B. Errors for Sinusoidal Input Signals

If the input signal of an RC differentiator is of the form

$$e_i = E_i \sin \omega t,$$

the output (see Equation 4, above) will be

$$e_o = RC \frac{d(E_i \sin \omega t)}{dt} - RC \frac{de_o}{dt} \quad (10)$$

the solution of this equation is

$$e_o = \frac{\omega R C E_i}{\sqrt{1 + \omega^2 R^2 C^2}} \cos(\omega t + \phi) \quad (11)$$

*To be described under capacitors.

where $\tan \phi = -\omega RC$. The output from a perfect differentiator would be

$$e'_o = \omega RC E_i \cos \omega t. \quad (12)$$

Equation 11 approaches the correct value (of Equation 12) for $\omega^2 R^2 C^2 \ll 1$.

In this case Equation 10 can be represented as

$$e_o = (1 - \frac{1}{2} \omega^2 R^2 C^2) \omega RC E_i \cos (\omega t + \phi),$$

i.e. the output deviates from the correct output by

$$\text{the fractional amplitude error: } -\frac{1}{2} \omega^2 R^2 C^2$$

$$\text{and the phase error: } \phi = \tan^{-1}(-\omega RC)$$

In many practical cases, the phase error can be tolerated. If the input signal is composed of sine functions of different frequencies, the phase error can frequently be tolerated if for each component of the radian frequency ω_i the phase shift is $\phi_i = \text{const. } \omega_i$. The differentiated wave form remains undistorted in this case.

C. Errors for Transient Input Signals

If the derivative of the input signal changes discontinuously at $t = t_o$ from $\frac{de_1}{dt}$ to $\frac{de_2}{dt}$, as shown in Figure 3.5a, Equation (7), above cannot be applied

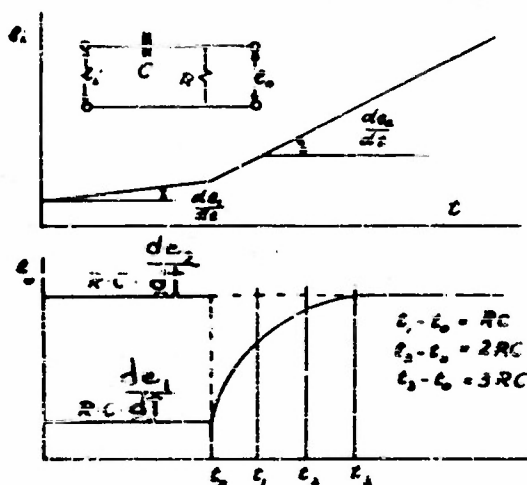

Figure 3.5

The output voltage, for any time after $t = t_0$ is (Equation 4)

$$e_o = RC \frac{de_i}{dt} - RC \frac{de_o}{dt}.$$

The solution of this equation is for $t > t_0$

$$e_o = RC \frac{de_2}{dt} + A e^{-\frac{t-t_0}{RC}},$$

where $A = RC \left(\frac{de_1}{dt} - \frac{de_2}{dt} \right)$.

The error is, therefore

$$e_f = RC \left(\frac{de_1}{dt} - \frac{de_2}{dt} \right) e^{-\frac{t-t_0}{RC}}.$$

or, if e_i was constant prior to t_0 (i.e. $\frac{de_1}{dt} = 0$).

$$e_f = -RC \frac{de_2}{dt} e^{-\frac{t-t_0}{RC}}.$$

The error is a maximum at $t = t_0$ and diminishes exponentially as shown in Figure 3.5b. The error amounts to

| | |
|------------|--------------------------------|
| 36 percent | after a time lapse of $t = RC$ |
| 13.5 | $2 RC$ |
| 5 | 3 |
| 1.8 | 4 |
| 0.7 | 5 |

The output of a perfect differentiator is indicated by the dotted line.

3.12 RC Differentiator with Feedback Amplifier

A. Negative Feedback

Only a small output voltage can be obtained from the simple RC differentiator if the error is to be kept low. It is usual, therefore, to

follow the differentiator with an amplifier having sufficient gain to bring the differentiator output to a useful level. A DC amplifier is required if it is to handle slow varying signals, but such an amplifier will tend to drift (and this drift will appear as a signal), unless stabilized by feedback. A simple way of combining a feedback amplifier with an RC differentiator is shown in Figure 3.6.

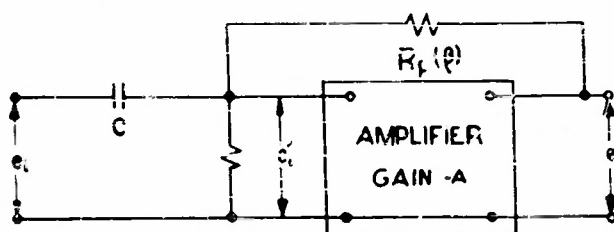

Figure 3.6

The effect of such an arrangement, where the output of the amplifier is reversed with respect to the input and is fed back to the output of the RC network, is to lower the effective value of R to $R/(1+A)$. The error as well as the voltage e_i' are correspondingly reduced by a factor $1/(1+A)$. If more signal is required and if a greater error can be tolerated, only a fraction β of the amplifier output need be fed back. In this case R is reduced to only $R/(1+\beta A)$. See Rad. Lab. Vol. 21, p. 69 for a practical circuit.

B. Positive Feedback

Instead of applying negative feedback to the output of the differentiator, one can apply positive feedback to the input of the RC network as shown in Figure 3.7. The error associated with the simple RC network can be completely eliminated with this circuit, however, at the risk of instability.

The signal e_i is applied to the input of the RC network. The signal e' appearing across R is amplified, and a part β of the amplifier output is fed back to the input terminals. The signal across R is

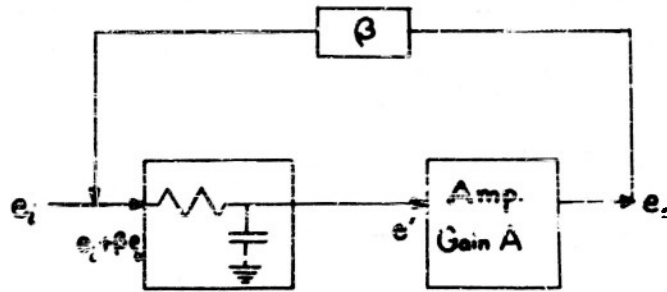

Figure 3.7

$$e' = RC \frac{d}{dt} (e_i + \beta e_o) - RC \frac{de'}{dt}$$

since $e_o = A \cdot e'$,

$$\frac{e_o}{A} = RC \frac{de_i}{dt} + \beta RC \frac{de_o}{dt} - \frac{RC}{A} \frac{de_o}{dt}.$$

The last two terms of this equation cancel for $\beta = \frac{1}{A}$; in this case the output signal is

$$e_o = ARC \frac{de_i}{dt}.$$

A practical circuit is shown in Figure 3.8

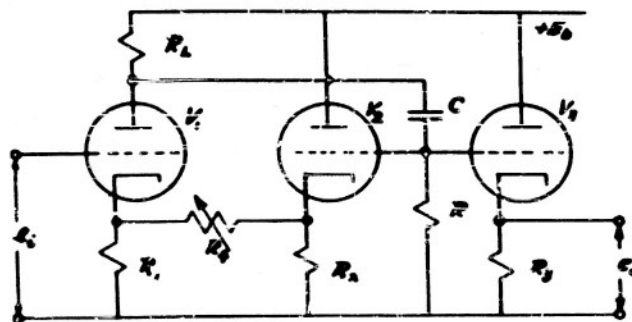

Figure 3.8

The input voltage e_i is applied to the grid of the first triode (high trans-conductance triode), and the output in the plate circuit to the differentiating network C-R. The voltage appearing across the resistor is applied to the

grids of the second and third tube, the second tube providing the feedback into the input via the resistors R_1 , R_2 , and R_4 , the third tube acts as an impedance changer. For the frequency range from 100 to 20,000 cps a resistance of 25,000 ohm for R_1 and a capacitance of $400 \mu\text{F}$ for C are recommended. The value of R_4 is only moderately critical ($\pm 10\%$).

(Reference, see O.H. Schmitt and W. E. Tolles, Rev. Sc. Inst. 13 (1942), 115-118, #3.)

3.2 Inductive Differentiators

3.21 Simple RL Circuits

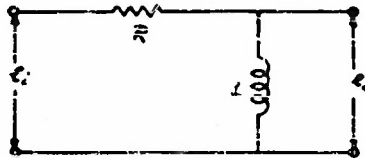

Figure 3.9

The input signal e_i to be differentiated is applied to the circuit of Figure 3.9, consisting of a resistance R and an inductance L with negligible resistance. If the reactance of L is small compared to the resistance, i.e. for a sinusoidal input voltage of radian frequency $\omega = 2\pi f$, if

$$\omega L \ll R, \text{ or if } T \gg T_0$$

where $T = \frac{L}{R}$ is the time constant of the circuit, and T_0 is the time of change of the applied signal, then the current i will, at any instant be proportional to the applied voltage e_i , $i = e_i/R$. The voltage between the terminals of the inductance will be

$$e_o = -L \frac{di}{dt} = -\frac{L}{R} \frac{de_i}{dt} \quad (1)$$

If $\frac{L}{R}$ is small, the differentiation is nearly correct, but the output e_o is small. Increase of $\frac{L}{R}$ increases the output but causes a departure from the correct value of the differentiation.

The differentiating method with an inductance is of advantage where high efficiency (ratio of differentiated output voltage to input voltage) but only moderate accuracy are required.

A. General Errors in inductive differentiators

inherent errors

If the voltage e_o across L cannot be neglected, $i = \frac{e_i - e_o}{R}$.

Therefore

$$\begin{aligned} e_o &= -L \frac{di}{dt} = -L \frac{d(e_i - e_o)}{dt} \\ &= -L \frac{de_i}{dt} + L \frac{de_o}{dt}. \end{aligned}$$

If furthermore the resistance R_L of the inductor L cannot be neglected, (Figure 3.10), then

$$e_o = -L \cdot \frac{di}{dt} + i \cdot R_L.$$

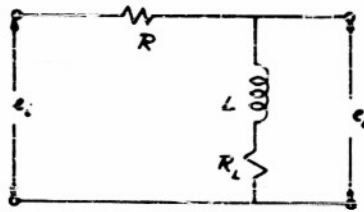

Figure 3.10

Therefore, the output of the differentiator will be

$$e_o = -L \frac{de_i}{dt} + L \frac{de_o}{dt} + \frac{R_L}{R} (e_i - e_o). \quad (3)$$

The last two terms in Equation 3 represent the errors of the differentiator. Of these, the first error (inductance error, f_2) can be minimized by reducing the reactance ωL of the inductor. The second error (Q-error, f_2) can be minimized by reducing the resistance of the inductor, i.e. by using a high Q inductor ($Q = \omega L / R_L$).

If the errors are small, then the inductance error is

$$\epsilon_{f_L} \approx -\frac{L^2}{R^2} \frac{d^2 e_i}{dt^2}$$

and the fractional inductance error is

$$\epsilon'_{f_L} \approx -\frac{L}{R} \cdot \frac{d^2 e_i}{dt^2} / \frac{de_i}{dt}$$

The Q-error is

$$\epsilon_{f_Q} \approx \frac{R_L}{R} e_i$$

and the fractional Q-error is

$$\epsilon'_{f_Q} = \frac{\epsilon}{Q} \cdot e_i / \frac{de_i}{dt}$$

Practical errors

For correct differentiation the inductor must be operated below the point where magnetic saturation occurs. Errors are also likely to occur when the inductor shows hysteresis properties. Experimental difficulties are likely to occur at low frequencies of a few cycles per second because of the unavailability of satisfactory high inductances, and at high (radio-) frequencies through stray capacitances and thus resulting parasitic resonances.

B. Errors for sinusoidal input signals

If e_i is a sinusoidal signal of the form

$$e_i = E_i \sin \omega t,$$

the the output of the differentiator will be

$$e_o = \frac{L}{R} (1 + \epsilon_L + \epsilon_Q) \cos(\omega t + \phi_L + \phi_Q).$$

Under the conditions that

- 1.) $R_L \ll R$
- 2.) $R^2 \gg \omega^2 L^2$, and
- 3.) $R_L^2 \ll \omega^2 L^2$,

the amplitude errors ϵ_L and ϵ_Q , and the phase errors ϕ_L and ϕ_Q can be computed.

The fractional amplitude inductance error is

$$\epsilon_L \approx \frac{1}{2} \omega^2 \frac{L^2}{R^2},$$

the fractional phase inductance error is

$$\tan \phi_L \approx \omega \frac{L}{R},$$

the fractional amplitude Q-error is

$$\epsilon_Q \approx \frac{1}{2Q^2} = \frac{R_L^2}{2\omega^2 L^2},$$

and the fractional phase Q-error is

$$\phi_Q \approx \frac{1}{Q}.$$

C. Errors for transient input signals

If the derivative of the input signal changes suddenly from zero to $\frac{de_i}{dt}$, the output voltage from an RL differentiator is

$$e_o = \frac{L}{R} \frac{de_i}{dt} \left(1 - e^{-\frac{tR}{L}}\right)$$

in analogy with the behavior of the RC differentiator, if

R in the RC circuit is replaced by $\frac{1}{R}$ in the RL circuit, and

C in the RC circuit is replaced by L in the RL circuit.

3.22 Transformer Differentiator

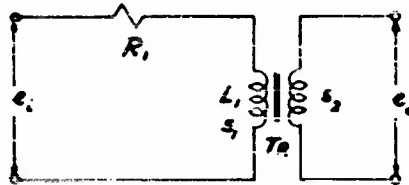

Figure 3.11

The voltage e_i to be differentiated is applied to the primary terminals of the transformer Tr in Figure 3.11. If the voltage across the inductance L_1 is small compared to e_i or to the voltage across R_1 , or if

$$\omega L_1 \ll R_1 \quad \text{or} \quad T_1 \ll T_0$$

where $T_1 = \frac{L_1}{R_1}$ is the time constant of the primary transformer circuit, and T_0 is the time of change of the applied signal, then the primary current i will, at any instant, be proportional to the applied voltage e_i , and so will be the flux Φ . The output voltage induced in the secondary coil (no load applied) is

$$e_o = - \frac{d\Phi}{dt} = \frac{M}{R} \frac{de_i}{dt}$$

where M is the mutual inductance. The output voltage is, therefore, proportional to the time derivative of the primary (input) signal.

If the voltage drop across the primary inductance cannot be neglected, but is still small ($iR \gg L \frac{di}{dt}$), then the output is

$$e_o = \frac{M}{R} \frac{de_i}{dt} - \frac{M}{R} \frac{L}{R} \frac{d^2 i_1}{dt^2}$$

where M is the mutual inductance of the transformer. The second term represents the inductance errors. The Q -error is zero, provided that the load on the transformer output is negligible.

The inductance error can be considerably reduced by an increase of R . A convenient way to accomplish this, consists in arranging the transformer (or an inductance) in the plate circuit of a tube with large plate resistance (pentode).

Reference, O. H. Schmitt and W. E. Tolles, *Rev. Sci. Inst.* 13, 115-118, 1942.

3.23 Feedback Inductive Differentiators

All circuits and considerations of feedback capacitive differentiators can be applied to inductive differentiators when the capacitance is replaced by a resistance and the resistance in the capacitive differentiator is replaced by an inductance.

3.3 Differentiating Circuits Containing L, C, and R.

If the input signal to be differentiated can be represented as a superimposition of sine functions

$$e_i = \sum E_i \sin(\omega_i t)$$

then the derivative has the form

$$\frac{de_i}{dt} = \sum \omega_i E_i \sin\left(\omega_i t + \frac{\pi}{2}\right),$$

i.e. 1. the amplitude of each component is multiplied by the circular frequency ω_i , and 2. the phase of each component is increased by $\frac{\pi}{2}$. The latter condition is not always required; the output wave shape remains undistorted when the phase shift of each component is $\phi = \frac{\pi}{2} - \text{const} \cdot \omega_i$.

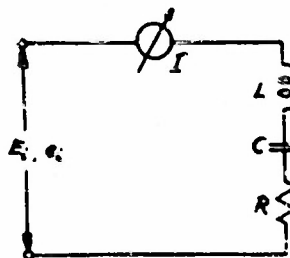

Figure 3.12

The circuit of Figure 3.12 acts as a differentiator, since the current is, within limits;

$$I = \omega_i \cdot E_i \cdot F$$

where

$$F = \frac{C}{(1 - \omega^2 CL)^2 + (\omega RC)^2}$$

The current appears, therefore, proportional to the applied voltage E_i , but multiplied by the circular frequency.

F is constant ($=1$) only when the highest frequency component of ω_i is far below the circular resonance frequency of the circuit, ω_r . The deviation of F and, therefore, the error in the result depends upon the Q -value of the circuit. The smallest amplitude error occurs with a circuit having a Q of $0.707 = (1/\sqrt{2})$ where the amplitude error is below 3 percent, even at frequencies as high as 50 percent of the circuit resonance frequency.

The phase angle between the applied voltage and the circuit is

$$\psi = \frac{\pi}{2} - \phi \text{ (current leading)}$$

where

$$\tan \phi = \frac{R \sqrt{\frac{C}{L}} \frac{\omega_i}{\omega_r}}{1 - \frac{\omega_i^2}{\omega_r^2}}$$

The value of ϕ is constant as long as the applied frequency is far below the resonance frequency of the circuit. The error depends upon the Q -value of the circuit and is smallest for a Q of $0.58, (1/\sqrt{3})$

Reference, see J. Gorner, ATM J. 082-3, July, 1940. The symbol F , above, corresponds to Gorner's symbols C.V.

3.4 Differentiation by Means of Transducers

Any transducer system operating with electromagnetic induction can be used as a differentiating system, since the voltage produced is

$$e_o = - S \frac{dN}{dt}$$

where S is the number of turns connected with a variation of the magnetic flux N .

If a voltage is to be differentiated by means of a transducer, the following system can be used (Figure 3.13).

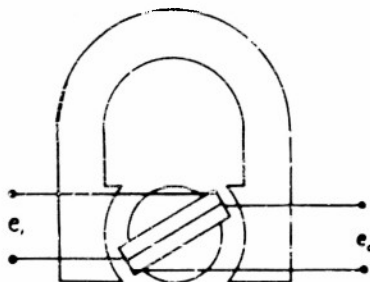

Figure 3.13

The input signal e_i to be differentiated is applied to an ordinary moving coil system. The frame of this system carries two separate coils. The mechanical inertia of the moving system must be small, so that the system follows the variation of the input signal with negligible delay.

The deflection α is, at any time, proportional to the applied signal:

$$\alpha = K_1 e_i,$$

and the angular velocity of the frame is

$$\omega = \frac{d\alpha}{dt} = K_i \frac{de_i}{dt}.$$

The movement of the frame in the magnetic field causes an induction of a voltage in the secondary coil. This voltage is proportional to the velocity

of the movement:

$$e_c = K_2 \frac{da}{dt} = K \frac{de_i}{dt},$$

therefore proportional to the time derivative of the input signal, provided that no current is drawn from the output and that the direct induction from coil 1 to coil 2 is negligible.

Reference Jahnke and Keinath, Gluckauf 57 (1921), p. 168, reported by J. Gorner, ATM J. 682-3, 1940, July.

4. INTEGRATION

4.0 General Considerations

4.1 Capacitive Integrator

4.11 Simple RC Integrators

Errors in RC Integrators

4.12 Capacitive Integrators with Feedback

4.13 Repetitive Acting RC Integrators

4.2 Inductive Integrators

4.3 Transducer - Integrators

4.31 Ballast Galvanometers

4.32 Rate - Servomechanism

4.33 Watt-Hour Meters

4.34 Oscillating Relay

4.4 Electrolytic Integrators (Coulometers)

4.41 Volume Coulometers

4.42 Weight Coulometers

4.43 Concentration Coulometers

4. Integration

4.0 General Considerations

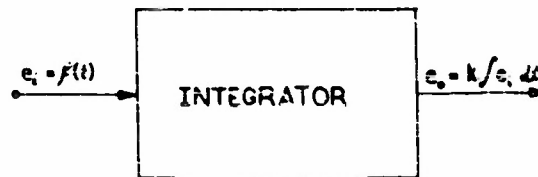

Figure 4.1

The general form of an electric analog integrator is shown in Figure 4.1. The input signal varies with time in the form $e_i = f(t)$. The output signal is $e_o = k \int e_i dt$.

The integrators described in the following perform integration with respect to time. If it is desired to evaluate the definite integral of e with respect to some other variable x , advantage may be taken of the relation

$$\int_{x_1}^{x_2} e dx = \int_{t_1}^{t_2} e \left(\frac{dx}{dt} \right) dt$$

which may be implemented by means of a differentiator, multiplier, and integrator as shown in Figure 4.2.

There are three types of problems which an integrator can solve.

Type A - find $\int e dt$ as a function of t (indefinite integral).

Type B - find $\int_0^{T_1} e dt$ for a particular value of T_1 (definite integral).

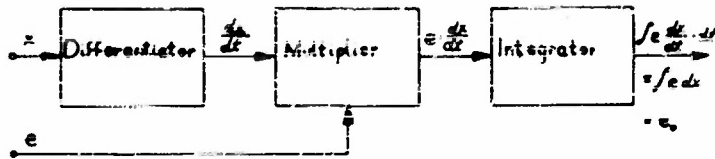

Figure 4.2

Type C - find T_1 for a particular value of $\int_0^{T_1} e dt$.

Integrators vary considerably in their abilities to solve these three types of problems. For example, the ballistic galvanometer is fundamentally incapable of solving Type A problems.

The simplest method of integration for short integration times is the one using a resistance-capacitance network (4.11). The method is likely to cause errors which may be reduced by the use of feedback amplifiers (4.12). Instead of an RC-network, an RL network may be used (4.2).

The use of transducers for integration is described in 4.3; the output appears as a mechanical displacement. For short duration signals, the ballistic galvanometer furnishes satisfactory results (4.31), while for long duration signals the rate servomechanism (4.32) and the ampere-hour meter (4.33) are more satisfactory. The electrolytic integrators (coulometers, 4.4) are simple systems, sometimes useful in experimental work.

All integrating systems, with the exception of the ampere-hour meter, have a limited operating time which can be increased by repetitive action. The RC integrator, for instance, can be used so that the capacitor is discharged when a certain voltage is reached, and the integration process can start over again. Such repetitive systems are described in connection with each system.

4.1 Capacitive Integrators

4.1.1 Simple RC Integrators



Figure 4.3

The capacitor C Figure 4.3 may initially be discharged ($e_o = 0$). The voltage across the capacitor is

$$e_o = \frac{1}{C} \int_{t_1}^{t_2} i dt.$$

Most input signals are available in the form of voltages, rather than currents. A current proportional to a voltage may be obtained by the insertion of a resistance R in the circuit as shown in Figure 4.4.

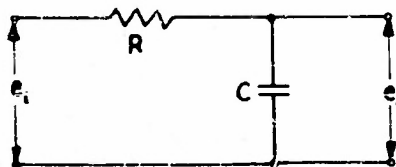

Figure 4.4

If the voltage across the capacitance is negligibly small or, if the impedance of C is small compared to R , i.e. for a sinusoidal input signal of the radian frequency ω

$$\frac{1}{\omega C} \ll R, \text{ or } \frac{1}{\omega CR} \ll 1,$$

or if the time constant of the circuit $T = R \cdot C$ is large compared to the time of integration T_o , $T \gg T_o$, then the current is e_i/R , and the output is

$$e_o = \frac{1}{RC} \int_{t_1}^{t_2} e_i dt.$$

If $R \cdot C$ is large, the integration is nearly correct, but the output e_o is small. Decrease of RC increases the output, but causes a departure from the correct value of the integration.

Errors in Capacitive Integrators

A. General

1. Inherent errors.

If the voltage across the capacitor is not negligibly small, then the current is

$$i = \frac{e_i - e_o}{R}$$

and the output is

$$\begin{aligned} e_o &= \frac{1}{RC} \int_0^t (e_i - e_o) dt \\ &= \frac{1}{RC} \int_0^t e_i dt - \frac{1}{RC} \int_0^t e_o dt. \end{aligned}$$

The error is, therefore,

$$\epsilon = - \frac{1}{RC} \int_0^t e_o dt.$$

If the error is small, then the output is approximately

$$e_o \approx \frac{1}{RC} \int_0^t e_i dt.$$

In this case the error, expressed by the input signal, is

$$\epsilon = -\frac{1}{R^2 C^2} \int_0^t \int_0^t e_i dt dt.$$

The fractional error is, for a definite time T,

$$\epsilon_f = -\frac{1}{RC} \frac{\int_0^T \int_0^T e_i dt dt}{\int_0^T e_i dt}. \quad (1)$$

Since the definite integral $\int_0^T e_i dt$ depends only upon T and does not contain the variable t, the integral can be expressed by K(T) and the fractional error can be expressed by

$$\epsilon_f = -\frac{1}{RC} \frac{\int_0^T K(T) dt}{K(T)dt} = -\frac{T}{RC}.$$

2. Practical errors

a. Dielectric Absorption in Capacitors

Dielectric absorption (residue formation or soaking effect) causes the effective capacitance of any practical capacitor to vary with the time of application of a signal or to vary with frequency, and thus causes a departure from proportionality between voltage and charge. The effect can be reduced through the use of capacitors with polystyrene and polyethylene dielectrics. Satisfactory results have been reported with Western Electric Polystyrene type capacitors, and such of the Condensor Products, Corp., types LA and PA.

b. Leakage in Capacitors

Leakage in practical capacitors causes a departure from proportionality between capacitor voltage and the time integral of charging current,

and should be as small as possible. It is possible to reduce this error with polystyrene and polyethylene capacitors, or to completely compensate for a constant capacitor leakage by means of positive feedback. A discussion of methods and practical circuits is given in Vol. 19 of the M.I.T. Radiation Laboratory Series, "Waveforms," page 659.

c. Stray Input Signals

Any d-c component of a stray input voltage will be continuously integrated and will produce a constantly increasing error. If the magnitude of the stray d-c component is e_n , the error will be

$$\epsilon_s = \frac{1}{RC} \int_0^T e_n dt.$$

B. Errors for Sinusoidal Input

If the input of an RC integrator is sinusoidal,

$$e_i = E_i \sin \omega t$$

then the output will be

$$e_o = \frac{1}{RC} \int_0^t (E_i \sin \omega t) dt - \frac{1}{RC} \int_0^t e_o dt.$$

The solution of this equation is, for the steady state,

$$e_o = \frac{-E_i}{\sqrt{1 + \omega^2 R^2 C^2}} \cos(\omega t + \phi). \quad (1)$$

where $\tan \phi = \frac{1}{\omega RC}$.

The output of a perfect integrator would be

$$e_o^1 = -\frac{E_i}{\omega RC} \cos \omega t \quad (2)$$

e_o approaches the correct value e_o^1 if

$$\omega RC \gg 1.$$

In this case equation (1) can be represented as

$$e_o = \frac{-E_i}{\omega RC} \left(1 + \frac{1}{\omega CR}\right)^{-\frac{1}{2}} \cos(\omega t + \phi)$$

$$\approx \frac{-E_i}{\omega RC} \cos(\omega t + \phi) + \frac{E_i}{2(\omega RC)^2} \cos(\omega t + \phi)$$

i.e. the output deviates from the correct value by the amplitude error:

$$-\frac{E_i}{2(\omega RC)^2}$$

and the phase error:

$$\tan^{-1} \frac{1}{\omega RC}$$

The fractional amplitude error is:

$$\epsilon_f = \frac{e_o^1 - e_o}{e_o^1} = -\frac{1}{2\omega RC}$$

In many practical cases the phase error can be tolerated.

C. Errors for Transient Signals

If the input signal changes discontinuously, as shown in Figure 4.5, the response of a perfect integrator would be linear (dotted line). The actual output of the RC integrator is an exponential curve.

The output corresponds to the correct value only at the start of the transient signal. The output voltage for any time after $t = t_0$ is

$$e_o = \frac{1}{RC} \int_0^t e_i dt - \frac{1}{RC} \int_0^t e_o dt.$$

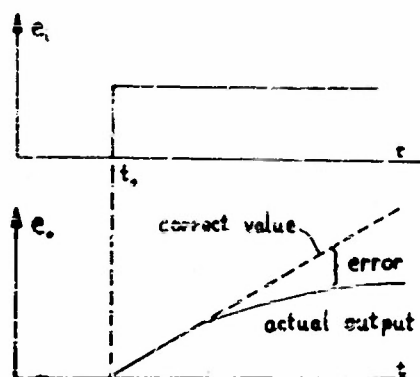

Figure 4.5

The solution of this equation is

$$e_o = e_i \left(1 - \epsilon^{-\frac{(t - t_o)}{RC}} \right).$$

The output from a perfect integrator would be

$$e_o = \frac{e_i \cdot (t - t_o)}{RC}$$

and the error is,

$$\epsilon = -\frac{1}{RC} \int_0^t e_o \, dt.$$

If the error is small, i.e., if

$$e_o \approx \frac{e_i(t - t_o)}{RC}.$$

then

$$\epsilon = -\frac{(t - t_o)^2}{R^2 C^2}$$

and the fractional error is

$$\epsilon_f = \frac{\epsilon}{e_o} = \frac{t - t_o}{RC}.$$

4.12 Capacitive Integrators with Feedback

A. RC Integration with Negative Feedback

Since only a small voltage output can be tolerated with the simple RC integrator, it is usual to follow the integrator with an amplifier having sufficient gain to bring this voltage up to a useful level. The amplifier must be a D.C. amplifier if it is to handle very slow signals. The amplifier can be incorporated with the integrator in a feedback circuit (similar to that used with the RC differentiator), as shown in Figure 4.6.

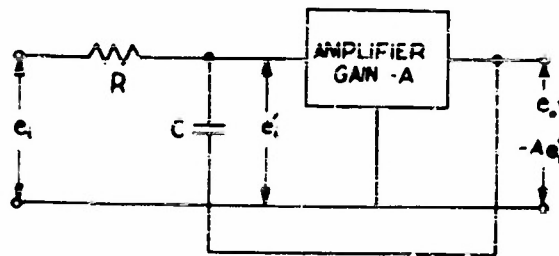

Figure 4.6

The effect of such an arrangement, where the output of the amplifier is reversed with respect to the input, is simply to raise the effective value of C to $C \cdot (A + 1)$. The integrator then appears to have a capacitance of $C \cdot (A + 1)$ and the error as well as the voltage e'_1 are correspondingly reduced. Since the capacitor blocks D.C., the effect of the feedback does not stabilize the D.C. zero-point or gain, but it does allow the use of a considerably smaller capacitor, and smaller capacitors generally have smaller loss factors. For a practical circuit, see Elmore and Sands, *Electronics*, pages 76-78 and pages 198-201.

The gain of the amplifier can be made extremely large, thus producing an extremely large effective capacitance, by supplying the amplifier with an

internal positive (regenerative) feedback loop. For a circuit of this type see The Radiation Laboratory Series, Volume 21, page 81, and Volume 19, pages 665-666.

B. RC Integration with Positive Feedback*

Perfect integration is possible by the use of an RC integrator within a positive feedback loop, as indicated in the block diagram of Figure 4.7.

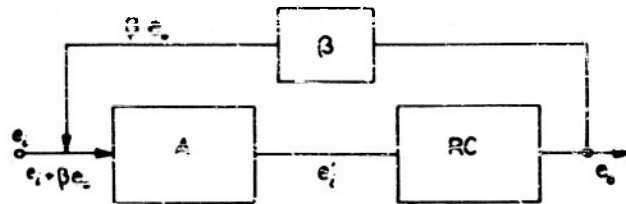

Figure 4.7

The input signal is amplified and fed through an RC integrator. A certain portion, β , is fed back so that it adds to the input. The output of an RC integrator is related to its input by the equation

$$e_o = \frac{1}{CR} \int (e_i' - e_o) dt.$$

In this case,

$$e_i' = A(e_i + \beta e_o).$$

Thus:

$$e_o = \frac{1}{CR} \left[\int (\Delta e_i + A\beta e_o - e_o) dt \right].$$

*So called "boot strap" integrators.

If $A\beta = 1$ then the second two terms disappear and the integration is perfect. The result is clearly unchanged if the amplifier and the RC network are interchanged in position. The condition $A\beta = 1$ is also the condition for oscillation of the system. Thus as A or β are increased the integration of the system improves, but only approaches perfection as the system reaches the limit of stability.

An example of a practical circuit using this principle is shown in Figure 4.8. (See the Radiation Laboratory Series, Volume 19, page 663.)

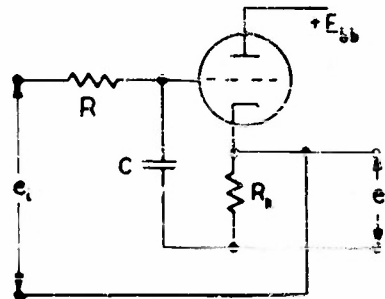

Figure 4.8

Here the amplifier is a cathode follower, so $A \approx 1$, and all of the output is fed back, so $\beta = 1$. This circuit requires a floating input. A circuit embodying essentially the same principle, and useful for grounded inputs, is shown schematically in Figure 4.9. The condition for perfect integration is again $A\beta = 1$, where β is now $R_1 / (R_1 + R_2)$.

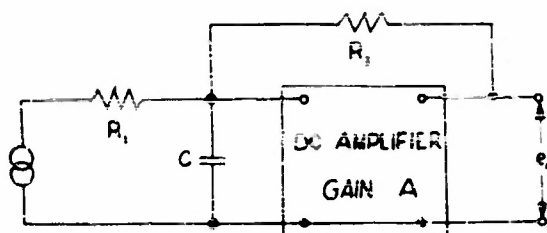

Figure 4.9

4.13 Repetitively Acting RC Integrators

Since the inherent errors of a RC integrator increase with the magnitude of the integral and with time, accurate long-time integration is best accomplished by integrating until the magnitude of the integral reaches a small value, at which time the value of the integral is reset to zero and integration is re-started. The total magnitude of the integral will be equal to this pre-determined unit integral value multiplied by the number of times that the integration is performed. The magnitude of the unit integral, and the time of unit integration, should be small in order to obtain results of good accuracy. An arrangement of this type is shown schematically in Figure 4.10.

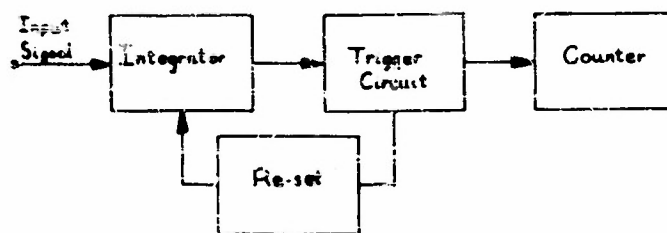

Figure 4.10

The most critical part of this arrangement is the reset device. Accurate integration requires that reset time be reduced to a minimum, but, due to dielectric absorption, it is difficult to completely discharge a condenser instantaneously. Use of a high quality capacitor, and maximum integration time units, should make the method capable of reasonable accuracy.

Many practical circuits have been described using this principle. A simple circuit, using a neon bulb to reset the integrator is described by Watt, RSI 17 (1946), 334.

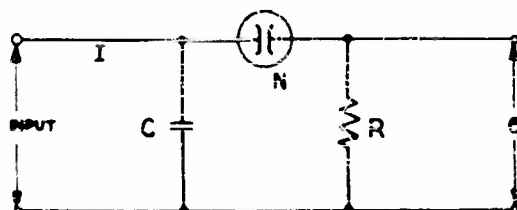

Figure 4.11

The current or the current impulses I to be integrated charges the capacitor C ($1,000 \mu\text{F}$) until the voltage reaches the firing potential of the glow lamp N (General Electric 1/4 watt glow lamp in bulb T 4 1/2). The tube then fires and passes a current through the resistance R ($5,000$ ohms) until the potential of C falls below the minimum discharge voltage of N . The discharge extinguishes and C begins to recharge. A pulse recorder measures the total charge passed through N .

The leakage resistance across the glow lamp should be greater than 10^{12} ohms. The base of the tube should be removed and the bulb coated with Ceresin wax near the leads. For consistent results the tube should be electrostatically shielded and kept in total darkness.

The integrating device works satisfactorily for currents ranging from $4 \cdot 10^{-9}$ to $5 \cdot 10^{-5}$ amps. The average charge for the described setup is 0.0416 ± 0.0004 microcoulombs per count. The voltage impulse e_0 across R reaches an amplitude of 5 volts and a duration of about 50 microseconds. An over all accuracy of 2 percent can be obtained. The integrator is adequate only for current sources or for very high voltage sources.

A more flexible integrator of the repetitive type, using a d-c amplifier, a Miller integrator, and a multivibrator trigger circuit, is described by Lewis and Clark, J.S.I. 26 (1949), 80. This circuit can be used for the time-integration of currents as low as 10^{-8} amperes full-scale and voltages up to 0.5 volts within an accuracy of 3% full scale. The accuracy is limited by the d-c amplifier. If potentials in excess of 10 volts are available the d-c amplifier can be omitted and integration can be performed with an accuracy of 0.02%.

4.2 Inductive Integrators

If a voltage e is applied across an inductance, the current, i , varies as:

$$i = \frac{1}{L} \int e \, dt \quad (1)$$

where t is the time in seconds and L is the inductance in henries. A voltage output may be obtained by using the circuit of Figure 4.12.

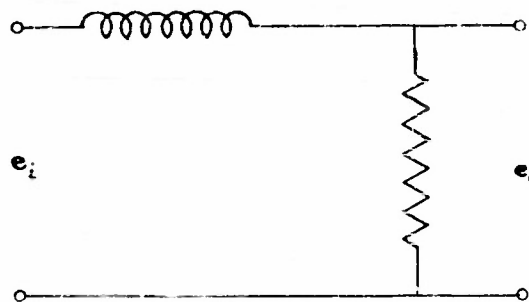

Figure 4.12

The error produced by the resistance will be small if the time constant of the circuit L/R is much larger than the time corresponding to the slowest variations in e_i which are to be measured. More exactly, the analysis of the RC integrator applies if RC is replaced by L/R . Since the inductance must be large, except for very fast signals, it must be iron cored, and is subject to hysteresis, saturation and internal resistance. For this reason, LR integrators are not very practical. For purpose of error analysis, the resistance associated with the inductance can be included in the circuit R.

The use of a negative feedback amplifier as in the circuit of Figure 4.13 has the effect of reducing the effective value of R to $R/(1+A)$. Although this method will reduce R to an arbitrarily small value, the coil resistance is not affected, and will represent the limit to the accuracy of the integration.

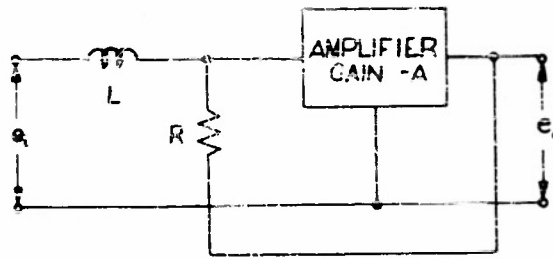

Figure 4.13

Positive feedback systems as in Figure 4.14 are possible, where the error is entirely eliminated as the circuit approaches the limit of stability. The analysis of Sec. 4.12 is analogous.

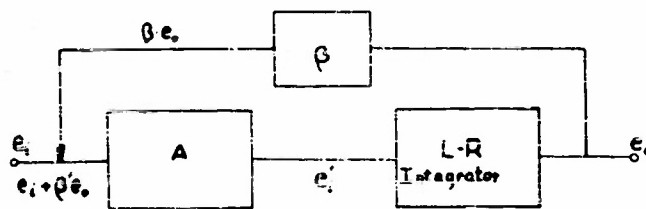

Figure 4.14

4.3 Transducer Integrators

4.31 A. Ballistic Galvanometer*

The instrument consists of a galvanometer system of a long period. A current pulse $\int idt$ or a voltage pulse $\int edt$ is applied to the system. The duration of the pulse should be small compared to the period of the galvanometer system so that the system does not move appreciably for the duration of the pulse. The pulse produces a torque in the system, and the effect, i.e., the initial velocity of the system and the throw (final deflection α), is proportional to this torque

$$\alpha = S_i \int idt \text{ or } \alpha = S_e \int edt$$

where S_i is the ballistic current sensitivity of the system, expressed in radians/ampere seconds, and S_e the ballistic voltage sensitivity in radians/volt seconds. The ballistic sensitivity can be found from the static sensitivity X (X expressed in radians/amp or radians/volt) for undamped conditions.

$$S_i = X \cdot \frac{2\pi}{T}$$

T is the time required for a double swing; i.e. the time between two successive passages in the same direction through the zero point. When a ballistic galvanometer is critically damped the ballistic sensitivity is reduced by $\frac{1}{e}$ (e = Napierian base = 2.718) so that

$$S_i = X \cdot \frac{2\pi}{eT}$$

If the duration of the applied pulse is not small compared to the period of the galvanometer, the deflection is

$$\alpha' = \alpha \left(1 - f \frac{\tau^2}{T^2}\right)$$

*To be described in detail under "output transducers."

where α is the deflection produced by an instantaneous current surge, τ is the duration of the input signal, and T is the period of the undamped galvanometer. The factor f depends on the wave form of the pulse, $f = 1.6$ for a square wave pulse. For other wave forms provided they have no minimum, f is smaller (Diesselhorst, *Annalen der Physik* 9 (1902), 458 and 712).

Moving coil systems are generally preferred, although the ballistic sensitivity of needle galvanometers can be much higher. Long period galvanometers permit the reading of the final deflection relatively easily and accurately. Critical damping of the system is desirable to shorten the waiting time between successive observation.

R. Fluxmeter

A special form of the ballistic galvanometer, well suited for integration, is the fluxmeter. It consists, in principle, of a moving coil type ballistic galvanometer, with very weak torsional restoring force (light suspension) which is greatly overdamped. The deflection of such a galvanometer is independent of the duration of current flow. When a current integral ($\int idt$) is applied, the galvanometer moves rapidly to its final position; it appears to stand deflected for some time and returns extremely slowly to its zero position. In order to bring the galvanometer more rapidly into zero position, it is frequently desired to apply an appropriate current pulse in the opposite direction. (Notes on moving coil galvanometers, Notebook ED2(1), 1950, Leeds and Northrup Company, Philadelphia, Pa.)

4.32. Rate-Servomechanisms

A rate-servomechanism integrator contains a motor controlled by a servomechanism in such a way that the speed of the motor is maintained proportional to the input signal. The total rotation of the motor shaft is equal to the time integral of the shaft velocity and thus is proportional to the time integral of the input signal. A block diagram of a practical system

is shown in Figure 4.15. The tachometer, mechanically coupled to the motor,

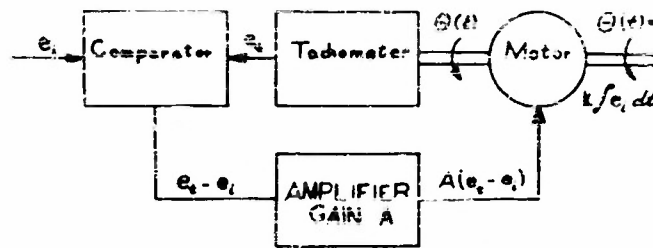

Figure 4.15

produces a voltage e_t which is proportional to the angular velocity $\frac{d\theta}{dt}$ of the motor. This voltage e_t is compared with the signal voltage e_i in a comparing network. Any inequality between e_t and e_i is multiplied by the amplifier and applied to the motor in such a way as to reduce the inequality to zero. Thus e_t is maintained equal to, and the angular velocity is maintained proportional to, the signal voltage e_i . Total shaft rotation, equal to the time integral of the motor speed, will then be proportional to the time integral of the signal voltage e_i .

Due to the finite speed of response of the motor, the mechanism is subject to error if the rate of change of input signal exceeds a critical value. It is possible to eliminate the effect of these errors by integrating them and running the motor at a greater than normal rate until the magnitude of the integrated error is reduced to zero.

The most critical part of a rate-servomechanism is the tachometer, which must produce a voltage proportional to the speed of the motor. The requirements are particularly severe if the signal passes through zero and becomes negative.

For references on rate-servomechanism integrators, see Rad. Lab. Series, Vol. 21, p. 85; on tachometers Vol. 21, p. 74 and Vol. 17, p. 374-376; on practical rate servos Vol. 21, p. 480-489. A practical integrator of this type with a mean error of about 0.1% is described by Buzzell and Sturtevant, RSI 19 (1948), 688. The integrator will accommodate signals from 15 millivolts to 1.5 volts.

4.33 Ampere-Hour and Watt-Hour Meter Integrators*

A. Permanent Magnet Ampere-Hour Integrator

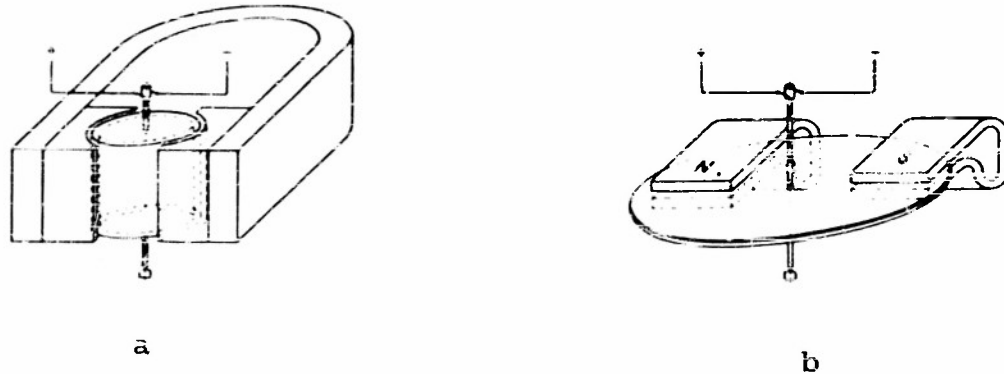

Figure 4.16

The instrument (Figures 4.16 a and 4.16 b) is applicable for DC integration and acts like a DC electrometer. It contains a rotor in the field of one or two permanent magnets. The rotor is either bell- or drum-shaped (Figure 4.16 a) or disk-shaped (Figure 4.16 b), and contains usually three sets of windings. The mechanical torque produced by the interaction of the magnetic field of the windings and the permanent magnet is proportional to the current passing through the windings. Connection to the rotor is made through a commutator and two brushes of precious metal. An aluminum disk suspended between the poles of a magnet produces a retarding moment (through the generation of Eddy currents) so that the rotational speed of the rotor is always proportional to the current. A counter is mechanically connected to the shaft of the rotor and indicates the total number of rotations. The weight of the rotor is in the order of 40 to 85 g, the maximum current is about 100 mA, the torque is generally in the order of 10 gm, and the rotational speed for maximum current about 150 rpm. At currents between 10 and 100 percent of full load, the error is in general between 0.5 and 1 percent. At less than 10 percent of the maximum current the error increases

*To be described in detail under output transducers.

steeply because of friction. The use of an auxiliary current is recommended to reduce this error. Increase of temperature tends to produce a positive error (the instrument runs too fast) of 1 percent for an increase in temperature of 10°C . Reference, see G. Hommel, ATM J728-1, 1932, July.

R. N. Schweiger, RSI 23, (1952), 735, describes a practical integrator of this type in which a modified watt-hour meter is operated from the output of a gain-stabilized current amplifier. The output of the amplifier is made accurately proportional to the input signal by means of a servomechanism. The integrator is able to handle voltages as low as 0.1 volts and currents as low as 0.1 micro-ampere with an error of less than 1% of full scale.

B. Electrodynamic Watt-Hour Integrator

The instrument integrates DC as well as AC currents of variable frequencies. Its principle of operation is shown in Figure 4.17. A current

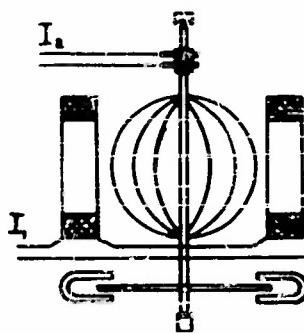

Figure 4.17

I_1 , passes through a pair of fixed coils and produces a magnetic field. Another current I_2 passes through a commutator and a set of (usually three) moving coils, also producing a magnetic field. These two fields interact and produce a torque in the moving coil system which is proportional to the product of both fields. An eddy current retarding disk between the poles of a permanent magnet produces a retarding torque so that the rotational speed is proportional to the product of both currents, and the total number of rotations, read off a mechanical counter, is proportional to the time

integral of this product. The voltage drop in the fixed coil is approximately 1 to 2 volts. The rotor coils are usually built for a current of 15 mA and a voltage of 10 v. The rotor weight is in the order of 100 to 180 g and the torque around 6 to 12 gcm. The minimum current required to turn the rotor is about 1 percent of full load; this limit can be further reduced by the use of auxiliary currents or fields. The error can be kept under 1 percent (except for very small currents) and depends upon temperature and stray magnetic fields.

Reference, see W. Beetz, ATM J752-7, 1938, January.

C. Induction Watt-Hour Integrator

The instrument is applicable only for AC of constant frequency. The system is shown schematically in Figure 4.18 and consists of a rotating aluminum disk between the poles of a laminated iron compound electromagnet.

This electromagnet has a "voltage coil" and two "current coils." By means of a lag coil (usually a short circuit loop around the voltage coil core) the flux of the voltage cores is placed in quadrature to the one produced by the current coils. Eddy currents induced in the disk in front of each pole are in the general form of concentric circles. These currents produce a magnetic field which reacts with the magnetic fields produced by the opposite pole face. The resulting torque turns the disk; a permanent magnet exercises a retarding torque so that the angular velocity is

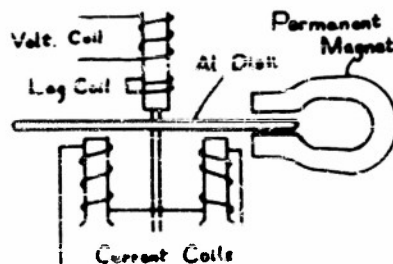

Figure 4.18

proportional to the product $I_1 \cdot I_2 \cdot \cos \theta$. The total number of rotations is, therefore, proportional to the time integral of this magnitude.

The accuracy of the induction type watt-hour integrator is as high as 0.5 percent for a range from 5 to 400 percent of rated load; the weight of the moving element is 13 to 16 g; the torque about 5 gcm. The power requirement for the voltage coil is 0.9 to 1.4 watt, the one for the current coils (rated for 5 amp) is 0.15 to 0.3 watt.

The induction watt-hour integrator may be used for the integration of only one input if a reference voltage or current is applied to the other input. The reference voltage must be of constant amplitude and phase.

Reference on watt-hour meters as integrators, see J. W. Gray, *Rad. Lab. Sev.*, Vol. 21, p. 87 on watt-hour meters, see H. B. Brooks and F. B. Silsbee in Pender-Dei Mar, *Electrical Engineers' Handbook*, 4th ed., J. Wiley and Son, New York and London, 1949, Sec. 5, 48 and W. Beetz, *ATM J752-1* and foll., 1936, January.

4.34 Oscillating Relay

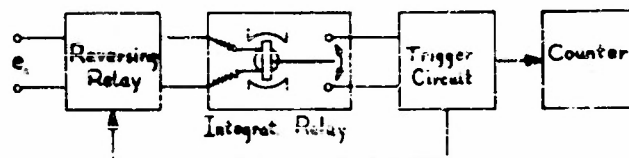

Figure 4.19

The oscillating or integrating relay can be considered as a fluxmeter (Sec. 4.31B) with repetitive action. The instrument consists of a moving coil system with a coil of the frameless type, having negligible restoring torque. The coil moves with a velocity ω proportional to the applied signal voltage e :

$$\omega = \frac{d\alpha}{dt} = k \cdot e.$$

The angle α traversed by the coil is, therefore, proportional to the applied voltage-time integral

$$\alpha = k \int e dt.$$

The coil moves until it strikes a contact stop. Making contact has the effect that the connected trigger circuit reverses the polarity of the input signal; the coil then swings in the opposite direction until another contact is made and the polarity is reversed again. Thus the coil oscillates at a frequency which is proportional to the applied signal voltage, and the total number of oscillations is proportional to the time integral of the signal. Coils are available which give values of the integral for one oscillation from 35 to 2,000 millivolt-seconds. When used as a current integrator, the smallest current that can be integrated is between 5 and 50 microamperes. The integral value is correct to within 1 percent for a range of input levels of 1:400. The optimum operating frequency is 1 cycle in 20 sec. The maximum input impedance is 2,000 ohms. A complete description of the relay (Weston, Model 806) and a reversing circuit is given by R. W. Gilbert, *Rev. Sci. Inst.*, 18 (1947), 328.

4.4 Electrolytic Integrators

The amount of chemical action M produced by the passage of a current i through an electrolyte is proportional to the total charge passing through the electrolytic cell,

$$M = A \cdot Q = A \int i dt.$$

The constant $A = \frac{\mu}{z \cdot e}$, where μ is the mass of an ion deposited or liberated at an electrode, z is its chemical valence, and e is the charge of an electron; or $A = \frac{\alpha}{z \cdot C}$, where α is the gram equivalent of a liberated or deposited ion, and $C = 96,501 \pm 10$ ampere seconds per gram equivalent (see Birge, *Rev. of Mod. Phys.*, 13, (1941), p. 238).

When an electric current passes through an electrolyte the liberated ions tend to react with the electrodes, thus altering their surface and producing a polarization e.m.f. of a polarity opposite to the applied voltage. The effect of this polarization is a non-linearity between applied voltage and current through the electrolyte (as long as the applied voltage is smaller than the polarization voltage) and an apparent increase in resistance of the electrolytic cell.

Electrolytic integrators are based on the measurement of the amount M of the ions deposited or liberated at the electrodes, or at one electrode. Either the volume is measured (4.41) or its mass, by weighing (4.42) or the concentration, by titration (4.43).

A. Water- or Oxygen-Hydrogen Voltameter

The instrument is based on the electrolysis of water. It contains two electrodes in an electrolyte, for instance platinum electrodes in 10 to 20 percent solution of (pure) sulphuric acid, or nickel electrodes in a 15 percent solution of sodium or potassium hydroxide, or a 40 percent solution of phosphoric acid. Two forms of vessels for the voltameter are shown in Figure 4.20 and Figure 4.21. Hydrogen is formed at the cathode, and oxygen at the anode. The volume of gas formed is proportional to the time integral of current passing through the solution.

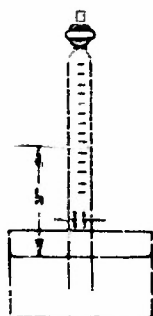

Figure 4.20

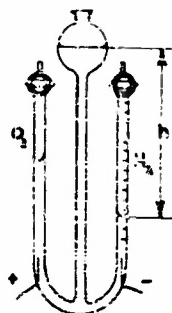

Figure 4.21

For high currents it is advantageous to measure the total amount of the hydrogen-oxygen mixture, as in Figure 4.20. With electrodes of 15 cm^2 area at a small distance, currents of 40 amperes can be sent directly through the cell (Kohlrausch, *Praktische Physik*, Vol. 2, p. 30, 1943, B. G. Teubner, Leipzig and M. S. Rosenberg, 1947, New York.) The liquid meniscus should always remain above the electrodes to avoid interruption of the current, arc formation and explosion. For small currents it is more accurate to measure the hydrogen volume only (Figure 4.21) (because of the formation of O_3 , H_2O_2 and $\text{H}_2\text{S}_2\text{O}_8$ at the anode) and to multiply the volume by $3/2$. An accuracy of a fraction of one percent can be obtained. The instrument is particularly useful in experimental investigations where currents in the order of .1 to 10 amperes are to be integrated during times up to several hours.

Errors are likely to arise at low voltages due to the non-proportionality of the voltage current characteristic and the apparent increase of the resistance of the cell. The coulometer should be operated for some length of time before any measurements are made, so as to saturate the electrolyte with hydrogen and oxygen.

One cubic centimeter of gas ($\text{H}_2 + \text{O}_2$) at 0°C and 760 mmHg is produced by 5.748 ampere seconds. The current-time integral can be found, therefore, from the (reduced) gas volume v_0 , in cc. from

$$\int i dt = 5.75 \cdot v_0.$$

The reduced volume v_0 can be found from the measured volume v from

$$v_0 = v \frac{b + a \cdot h - p_s}{760 \left(1 - \frac{t}{273}\right)}$$

where b is the barometric pressure in mmHg; h is the height of the liquid column in mm of electrolyte solution. The factor $a = \frac{\text{density of electrolyte}}{\text{density of mercury}}$ ($= .083$ for a 15 percent sulphuric acid solution) converts h into mmHg; h is either negative (Figure 4.20) or positive (Figure 4.21); p_s is the vapor pressure of the solution. This is about .9 times the vapor pressure of water at t , the temperature in degrees C of the electrolytically developed gas.

Technical hydrogen electrolytic integrators can be built for continuous and for repetitive operation; such integrators operate, in general, with currents as low as 50 to 100 microamperes; the (apparent) resistance of electrolytic cells is in the order of 100 ohms. A summary of such integrators can be found by W. Beetz, ATM, J772-1, Feb. 1939.

J. Sivertsen, *Electronics* 20, 1947, p. 92, June, describes a repetitively acting oxygen-hydrogen integrating cell. When a certain volume of gas is developed a heated wire explodes the mixture which is thus reconverted into water. The cell is able to handle currents from .05 to 80 mA. One cycle corresponds to the passage of 1.2 coulomb. The accuracy is indicated with .25 percent. The cell has a lifetime of 100,000 cycles.

Van Liempt, van Uden, and Vriend (*Physica* 10, 1943, p. 1) describe a coulometer for AC, consisting of tungsten electrodes in an electrolyte of sodium hydroxide. The volume of gas produced is proportional to the r.m.s. value of the current. A minimum current density of 1.8 amp/cm² electrode surface is required at 50 cps for correct operation. At higher frequencies the current density should be even higher.

C. G. and D. D. Montgomery describe an integrating radiation monitor (J. Franklin Institute, 241 (1946), 55) which consists of a Geiger counter, an electronic circuit, and an electrolytic integrator of the volumetric type. A radiation of $1r$ corresponds to a reading of 92 cm of rise of the level in an electrolytic cell.

B. Mercury Coulometer

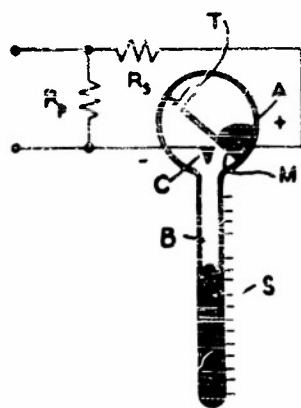

Figure 4.22

A glass vessel contains an aqueous solution of potassium mercuric iodide. The anode A consists of mercury, the cathode C of carbon. A separating membrane M of frosted glass between the cathode and the anode permits the free circulation of the electrolyte, but keeps the mercury separated in the anode space.

If current passes through the cell, mercury will go into solution at the anode and will be deposited on the cathode; it will then drip, through the electrolyte, into the capillary B where its volume can be read on a scale S.

When the capillary is filled, the glass vessel can be inverted, and the mercury runs through the tube T in the membrane, back into the anode space. In order to facilitate the flow of mercury the capillary should have an internal diameter of more than 4 mm, or should have elliptic cross section or internal ribs.

The instrument works best for currents in the vicinity of 20 mA, but can be used for other current ranges by the use of series and parallel resistances R_p and R_s . At less than 2 mA current through the cell, the polarization voltage is likely to cause errors; also the (apparent) resistance of the electrolytic cell varies with current. In the range 1:10, the error is, in general, between 1 and 2 percent. The (negative) resistance-temperature coefficient of the electrolyte can be compensated by a positive temperature coefficient (nickel) of the resistances R_p and R_s .

The instrument has the advantage of relatively high accuracy, freedom from mechanical parts and practically unlimited life.

Reference, W. Beetz, ATM J772-1, Feb. 1939, T-23 to 24, also Schultze, Z. Electrochemie, 27, 475 (1921), and W. von Krukowski, Grundzüge der Zählertechnik, Springer 1930.

4.42 Weight Coulometers

In one of its common forms, the coulometer consists of a platinum crucible used as cathode in which is suspended a pure silver anode surrounded by a porous cup to prevent anode impurities from falling on the cathode (see Figure 4.23). A 10-20% solution of very pure silver nitrate is used as an electrolyte. For accurate results, the cathode current density should be less than 0.02 amp/cm^2 and the anode current density should be less than 0.2 amp/cm^2 . The cathode crucible is carefully dried and weighed before and after plating, and the mass m of silver plated on it is accurately determined.

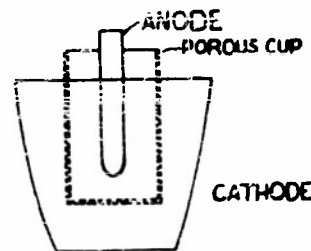

Figure 4.23

If m is the weight gain of the cathode crucible, then

$$\int_0^t i \, dt = 1118 m \text{ (ampere-seconds).}$$

A. Silver Coulometer

This coulometer has been much used in the electrochemical industry for the accurate determination of charge. An extensive discussion of the sources of error and their elimination is given by Rosa and Vinal in the Bull. Bureau of Standards, V. 13 (1916), 479, Sci. Paper #285.

B. Copper Coulometer

This coulometer is not as accurate as the silver coulometer, but will produce results accurate to within a fraction of a percent. In its usual form,

it consists of a sheet copper cathode suspended between two sheet copper anodes. The electrolyte used is made up as follows:

150 gm. $\text{CuSO}_4 \cdot 5\text{H}_2\text{O}$

50 gm. H_2SO_4

50 cc. ethyl alcohol

1000 cc. distilled H_2O .

For proper results, the cathode current density should be greater than 0.002 amp/cm² and less than 0.02 amp/cm². This coulometer is subject to large errors at low cathode current densities due to the presence of side reactions at the electrodes.

If m is the weight gain of the cathode

$$\int_0^t i \, dt = 3040 m \text{ (ampere-seconds).}$$

A complete discussion of the sources of error in this coulometer and attempts at their elimination is given in an article by Datta and Dhar, J. Am. Chem. Soc., 38 (1916), 1156.

4.43 Concentration Coulometers

In titration coulometers, the amount of reaction product produced by electrolysis is determined by means of a chemical reaction with a known quantity of a standard reagent. These coulometers are particularly useful in the integration of small currents because they obviate the errors arising in washing and drying the cathode, necessary in weight coulometers.

Iodine Coulometers

In the form described by E. W. Beiter, Trans. Electrochem. Soc. 88 (1945), 433, the electrolyte consists of a 4 percent aqueous solution of potassium iodide (KI). The cathode is a flat spiral formed from platinum

wire, the anode is a flat foil of platinum of 4 cm² area.

When current passes the cell the following reaction takes place

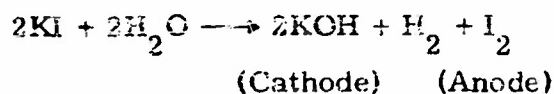

and

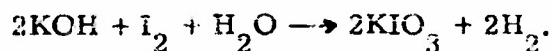

Immediately after the electrolysis the electrolyte is acidified with HCl, and the iodine is set free

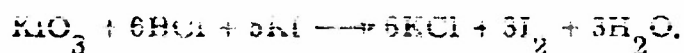

The amount of iodine produced is determined by titration with 1/20th Normal sodium thiosulfate standard solution.



$$1 \text{ cc. } \frac{\text{N}}{20} \text{Na}_2\text{S}_2\text{O}_3 = 0.006346 \text{ gm. I}_2 = 1.34 \text{ milliampere-hours.}$$

The accuracy is within a fraction of one percent over a current range from 2 mA to 200 mA. (See also Washburn and Bates, J. Am. Chem. Soc., 34 (1912), 1341).

ACKNOWLEDGEMENTS

I am much indebted to Mr. E. H. Davis who has collected most of the material and also has helped me in the preparation of this report.

Dr. W. L. Harries and Mr. G. F. Vanderschmidt have given me their valuable assistance in the treatment of the single topics and in the organization of the material. Mr. Paul Meretsky has helped me with the technical work and with proofreading.

My sincere gratitude goes to Mr. F. B. Isakson, Dr. Muckenhoupt, Mr. L. McKenzie, LCDR F. L. Thomas, and LT. D. deGraaf, all of the Office of Naval Research, for their help, their encouragement, and their patience.

Armed Services Technical Information Agency

Because of our limited supply, you are requested to return this copy WHEN IT HAS SERVED YOUR PURPOSE so that it may be made available to other requesters. Your cooperation will be appreciated.

AD

39116

NOTICE: WHEN GOVERNMENT OR OTHER DRAWINGS, SPECIFICATIONS OR OTHER DATA ARE USED FOR ANY PURPOSE OTHER THAN IN CONNECTION WITH A DEFINITELY RELATED GOVERNMENT PROCUREMENT OPERATION, THE U. S. GOVERNMENT THEREBY INCURS NO RESPONSIBILITY, NOR ANY OBLIGATION WHATSOEVER; AND THE FACT THAT THE GOVERNMENT MAY HAVE FORMULATED, FURNISHED, OR IN ANY WAY SUPPLIED THE SAID DRAWINGS, SPECIFICATIONS, OR OTHER DATA IS NOT TO BE REGARDED BY IMPLICATION OR OTHERWISE AS IN ANY MANNER LICENSING THE HOLDER OR ANY OTHER PERSON OR CORPORATION, OR CONVEYING ANY RIGHTS OR PERMISSION TO MANUFACTURE, USE OR SELL ANY PATENTED INVENTION THAT MAY IN ANY WAY BE RELATED THERETO.

Reproduced by
DOCUMENT SERVICE CENTER
KNOTT BUILDING, DAYTON, 2, OHIO

UNCLASSIFIED