

UNCLASSIFIED

AD NUMBER

AD039877

CLASSIFICATION CHANGES

TO: UNCLASSIFIED

FROM: CONFIDENTIAL

LIMITATION CHANGES

TO:  
Approved for public release; distribution is unlimited. Document partially illegible.

FROM:  
Distribution authorized to U.S. Gov't. agencies and their contractors;  
Administrative/Operational Use; 18 DEC 1953.  
Other requests shall be referred to Naval Ordnance Systems Command, Washington, DC 20360.  
Document partially illegible.

AUTHORITY

31 Dec 1965, DoDD 5200.9 NSNSWC ltr dtd 4 Dec 1974

**UNCLASSIFIED**

---

---

---

*Reproduced  
by the*

**ARMED SERVICES TECHNICAL INFORMATION AGENCY  
ARLINGTON HALL STATION  
ARLINGTON 12, VIRGINIA**



**DECLASSIFIED  
DOD DIR 5200.9**

---

---

**UNCLASSIFIED**

# Armed Services Technical Information Agency

Because of our limited supply, you are requested to return this copy WHEN IT HAS SERVED YOUR PURPOSE so that it may be made available to other requesters. Your cooperation will be appreciated.

# AD

# 39877

NOTICE: WHEN GOVERNMENT OR OTHER DRAWINGS, SPECIFICATIONS OR OTHER DATA ARE USED FOR ANY PURPOSE OTHER THAN IN CONNECTION WITH A DEFINITELY RELATED GOVERNMENT PROCUREMENT OPERATION, THE U. S. GOVERNMENT THEREBY INCURS NO RESPONSIBILITY, NOR ANY OBLIGATION WHATSOEVER; AND THE FACT THAT THE GOVERNMENT MAY HAVE FORMULATED, FURNISHED, OR IN ANY WAY SUPPLIED THE SAID DRAWINGS, SPECIFICATIONS, OR OTHER DATA IS NOT TO BE REGARDED BY IMPLICATION OR OTHERWISE AS IN ANY MANNER LICENSING THE HOLDER OR ANY OTHER PERSON OR CORPORATION, OR CONVEYING ANY RIGHTS OR PERMISSION TO MANUFACTURE, USE OR SELL ANY PATENTED INVENTION THAT MAY IN ANY WAY BE RELATED THERETO.

Reproduced by  
**DOCUMENT SERVICE CENTER**  
KNOTT BUILDING, DAYTON, 2, OHIO

# UNCLASSIFIED

**NOTICE: THIS DOCUMENT CONTAINS INFORMATION AFFECTING THE NATIONAL DEFENSE OF THE UNITED STATES WITHIN THE MEANING OF THE ESPIONAGE LAWS, TITLE 18, U.S.C., SECTIONS 793 and 794. THE TRANSMISSION OR THE REVELATION OF ITS CONTENTS IN ANY MANNER TO AN UNAUTHORIZED PERSON IS PROHIBITED BY LAW.**

# DISCLAIMER NOTICE

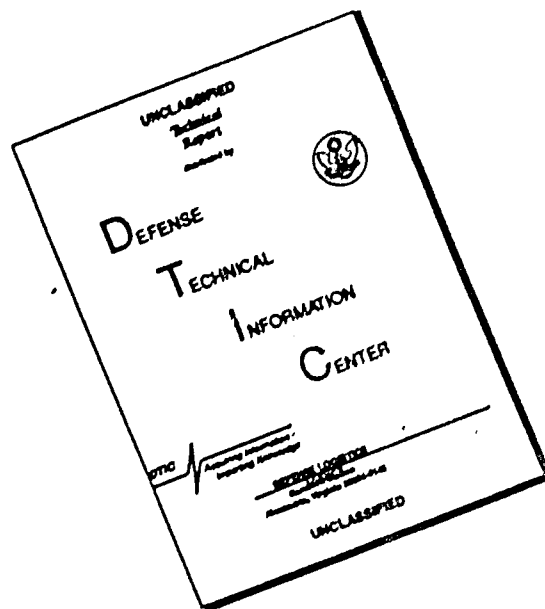

THIS DOCUMENT IS BEST QUALITY AVAILABLE. THE COPY FURNISHED TO DTIC CONTAINED A SIGNIFICANT NUMBER OF PAGES WHICH DO NOT REPRODUCE LEGIBLY.

**NAVORD REPORT**

**3592**

**AD No. 39777**  
**ASTIA FILE**

**FACTORS AFFECTING THE BEHAVIOR OF EXPLOSIVES TO MECHANICAL SHOCK**

*copy 98*

**18 DECEMBER 1953**



**U. S. NAVAL ORDNANCE LABORATORY**  
**WHITE OAK, MARYLAND**

**54AA**

**56440**

~~CONFIDENTIAL~~ 32

**FACTORS AFFECTING THE BEHAVIOR OF EXPLOSIVES TO MECHANICAL SHOCK**

By:  
George Svadeba

Approved by: Russell McGill  
Russell McGill, Chief  
Explosives Properties Division

**ABSTRACT:** The effect of a few of the various factors which influence the apparent sensitivities of explosives to mechanical impact have been investigated. These factors include variation in percent of kinetic energy available to the sample at various distances of fall and with various machines. The apparent sensitivities vary with basis for deciding whether or not each fall of the weight caused an explosion. Explosion may be detected by sound or by measuring volume of gas evolved. The electronic noisemeter is described in detail. The method of preparing the sample and its size also affect apparent sensitivities. This is discussed. Data from various sources is collected and included in this report to present an introduction to more recent work and to provide a collection of data in one source for reference purposes.

Explosives Research Department  
U.S. NAVAL ORDNANCE LABORATORY  
WHITE OAK, MARYLAND

1

~~CONFIDENTIAL~~

54AA

56440

CONFIDENTIAL

NAVORD Report 3592

18 December 1953

The results of investigations of factors affecting impact sensitivity results have been collected. The contributions by Dr. S. J. Jacobs of the discussion of the electronic noise indicator and of Appendix I, "The Electronic Noise Indicator for the Impact Machine", are acknowledged. Mrs. S. F. Duck and Mr. G. W. Reynolds, Physical Science Aides, operated the impact machines during the course of this work. Their patience and attention to detail contributed much to the accomplishment of this investigation. This investigation was authorized by task assignment C2c-23-1-54. The report is issued for information only and is not intended as a basis for action.

EDWARD L. WOODYARD  
Captain, USN  
Commander

  
J. E. ABLARD  
By direction

11  
CONFIDENTIAL

CONFIDENTIAL  
NAVORD Report 3592

Contents

	<u>Page</u>
Introduction .....	1
Apparatus .....	1
Basic Test Procedure and Data Reduction .....	2
Sample Preparation .....	2
Loading .....	3
Evaluation .....	3
A. Criteria .....	3
B. Bruceton Development .....	5
C. NOL Developments .....	5
D. Closed Chamber Testing .....	8
Miscellaneous Studies .....	10
A. Effect of Pressure on Impact Samples .....	10
B. Replacement of Sandpaper by Glass Cloth .....	13
C. Kinetic vs. Potential Energy .....	13
Conclusion .....	15
Appendix 1 .....	16
References .....	23

Illustrations

Table 1. Dependence of Fifty Percent Point on Sample Weight of Explosive .....	4
Table 2. Dependence of Fifty Percent Point on Noise Indicator Gain .....	7
Table 3. Volumes of Gas in cc Produced vs. Height Average of 10 Shots .....	9
Table 4. Volumes of Gas Produced in Successive Tests at 11.5 and 31 cm .....	11
Table 5. Frequency vs. Volume (from Table 4) .....	11
Table 6. Effect of Pressure vs. Sensitivity .....	12
Table 7. Glass Cloth as a Replacement for Sandpaper ...	14
Table 8. Comparison of Potential and Kinetic Energies Available on Impact .....	14
Figure 1. Noise Indicator for Impact Machine .....	22
Figure 2. Functional Parts of Electronic Noise Indicator .....	17
Figure 3. Equivalent Input Circuit .....	18

FACTORS AFFECTING THE BEHAVIOR OF EXPLOSIVES TO MECHANICAL SHOCK

Introduction

The investigation of the sensitivity of explosives to ignition by mechanical shock, as produced by the drop of a hammer, has shown that these materials can be arranged in a general order of behavior, the so-called impact sensitivities. This general order is thought to be of practical value in regard to handling of various explosives. The position of an explosive in this order is thought to reveal its military possibilities relative to safety insofar as general handling is concerned. The method of testing is very important as slight variation in the construction of an impact machine, its tools, strikers and anvils, may change the apparent order of sensitivity of explosives. Studies of the variations in tool designs are covered in reference (a) with reference to the following qualities sought in each design:

- (a) Ability to test all the military explosives
- (b) Simplicity and stability in operation
- (c) Reasonable sensitivity ordering (as related to other experience)

Apparatus

The major part of a drop test machine consists of the mechanism for dropping a weight through a chosen distance upon appropriate tools. The main requirements for a satisfactory design are:

- (a) Heavy bedding, that is unyielding tool support
- (b) Free fall of weight
- (c) Accurate weight release to introduce a minimum disturbance of free fall
- (d) Guides to control the motion of the weight on rebound

The important parts of a drop test machine from the standpoint of the results it will produce are the firing tools. These are usually a hardened steel anvil held rigidly on the bed plate by some anvil holder and a hardened steel plunger moving in an appropriate plunger guide. The details of the tool holders are of no great importance. The design of the tools themselves is of utmost importance.

CONFIDENTIAL  
NAVORD Report 3592

The NOL machine, received from the Explosives Research Laboratory, Bruceton, Pa., has a 337 cm drop height and is equipped with "type 12" tools. Briefly reviewing the design of these tools, the plunger is 1 1/4" diameter and 3 1/2" high. The top of the plunger is slightly rounded with a radius of curvature of 2 1/2". The anvil on which the sample was tested was also 1 1/4" diameter and 1 1/4" high. The tools have been made from Ketos oil hardening tool steel with a hardness between 55-60C, Rockwell. The weight used with this design is 2 1/2 kg. In some preliminary tests 1/2 and 1 kg weights have been employed.

Basic Test Procedure and Data Reduction

The basic unit test employed in this work is the 50 trial Applied Mathematics Panel (MARC) "up and down" method using test heights equally spaced in the logarithm of the height at 0.1 log unit intervals. (The log of a 10 cm drop is taken as 1.0.) The results have been analyzed by the method of reference (b). The application of this experimental procedure and method of analysis to the ERL type 12 machine has been described in detail in reference (c). The nomenclature and significance of symbols employed in this report will conform with those of references (a) through (d) and are briefly as follows:

- m - the 50% explosion height of the normalized (logarithmic) scale
- h - the 50% explosion height in centimeters
- $\sigma$  - the estimated standard deviation of the parent population (in logarithmic units)
- $\sigma_m$  - the estimated standard error of m
- $\sigma_\sigma$  - the estimated standard error of  $\sigma$

Sample Preparation

Those materials which are normally cast loaded are prepared for test by casting in a thin sheet, gently grinding in a mortar and screening. The test sample is a mixture of equal weights of the 16-30 and 30-50 U.S. standard sieve cuts. This preparation gives a sample composed of small cast lumps, large enough so that each contained several crystals of all ingredients. Furthermore, the packing properties (per cent voids in the loose sample) of all samples were similar, thus ensuring essentially constant-weight samples when volumetric loading is employed. In fact the sample weights were probably more nearly proportional to the

CONFIDENTIAL  
NAVORD Report 3592

crystal densities of the various materials, which is even better than having constant weight samples).

Other materials which cannot be cast, such as RDX, PETN, Explosive D, etc., are normally tested as received.

Loading

In routine testing, the sample of explosive, measured volumetrically by means of a small scoop, is placed on a one inch square of 5/0 Armour flint sandpaper which is in turn centered on the 1 1/4" diameter anvil. For sensitivity comparisons, test weighings are first made and scoop sizes chosen so that samples of each explosive weighing  $35 \pm 2$  mg are delivered. Data taken from reference (c) show the dependence of the 50% point on sample weight and are given in Table 1. The selection of the Armour 5/0 flint paper was made, following investigations at ERL, on various grades of sandpaper. It was found that with coarser grades, the apparent sensitivity of PETN became less as the particle size of the explosive decreased. It is believed that with the coarser grades, fine crystals were able to occupy interstitial cavities and were there partially protected from the effect of the blow. One factor introduced with the use of sandpaper was an apparent sensitization of explosives containing large amounts of oxidizing materials such as ammonium perchlorate and ammonium nitrate. It was shown that this apparent sensitization was introduced with any paper square as readily as with sandpaper, hence it was concluded that it was the paper - the organic material itself which permitted explosions with this oxidizing material. In most other cases, the ordering in sensitivity provided by these tests seem satisfactory.

Evaluation

A. Criteria

Having dropped weight on a given sample, one must then decide whether the result was, or was not, an explosion. Various criteria are available, but because of the difference in reactions among the various types of tools, the methods of interpretation used with each have not been uniform. With certain tool types, a sharp crack is usually produced upon explosion to provide a relatively simple criterion in the noise developed. In other designs, many partial explosions occur and consistent decisions over a long period of time and based on the human ear are difficult to make. With cup designs, the damage to the cup is a helpful aid in classifying results. Signs of burning or decomposition of sample residues have also been criteria in many tests.

CONFIDENTIAL  
NAVORD Report 3592

Table 1

Dependence of Fifty Percent Point on  
Sample Weight of Explosive

Explosive	Sample Wt. (MG)	h(cm)	n	$\sigma$	$\sigma_m$	$\sigma_e$
PETN	20	8.60	0.9343	0.1796	0.0347	0.0614
	30	11.15	1.0471	0.1719	0.0327	0.0566
	40	15.11	1.1791	0.0990	0.0199	0.0273
	60	17.66	1.2471	0.0680	0.0145	0.0173
	80	21.18	1.3259	0.1326	0.0263	0.0407
Tetryl	20	18.00	1.2551	0.0855	0.0179	0.0233
	30	21.24	1.3271	0.1796	0.0340	0.0602
	40	23.94	1.3791	0.1766	0.0335	0.0588
	60	33.57	1.5259	0.1192	0.0239	0.0354
	80	38.40	1.5843	0.0647	0.0143	0.0168
Comp A-3	20	31.85	1.5031	0.0571	0.0127	0.0148
	30	45.20	1.6551	0.0822	0.0170	0.0218
	40	49.27	1.6926	0.1237	0.0247	0.0372
	60	63.23	1.8009	0.0574	0.0130	0.0152
	80	71.63	1.8551	0.1127	0.0227	0.0330
HBX	20	62.03	1.7926	0.2843	0.0536	0.1174
	30	62.26	1.7942	0.4483	0.0850	0.2307
	40	103.10	2.0134	0.1251	0.0249	0.0377
	60	116.85	2.0676	0.2910	0.0548	0.1213
	80	199.11	2.2991	0.0703	0.0150	0.0180
TNT	20	65.46	1.8160	0.1559	0.0311	0.0516
	30	66.55	1.8231	0.1177	0.0231	0.0342
	40	85.33	1.9311	0.1250	0.0244	0.0369
	60	95.52	1.9801	0.1430	0.0281	0.0451
	80	115.71	2.0634	0.0571	0.0129	0.0142

B. Bruceton Development

The difficulties experienced at the Explosives Research Laboratory, Bruceton, Pa., in classifying results of individual shots into explosions, partial explosions, doubtful explosions, and non-explosions, by operators attempting subjective assessment of results of individual drop trials were so great that only stability of results were made with the type 12 machine rather than qualitative results. With an explosive so sensitive that there was no interpretation problem such as PETN, some work was done at ERL, reference (a), which showed that even in the absence of interpretational difficulties, a series of 50% heights did not, in general, show as small a variance as would be expected from the estimated standard error of  $m$  values calculated. Accordingly, a phase of study was begun to attempt to develop an objective method for evaluating the results of a single shot. Briefly stated, the output of a crystal microphone, placed at a fixed distance, was amplified, rectified, and the rectified signal impressed on the input of a cathode ray oscillograph with approximately a 1/10 second sweep frequency applied to the x axis. The gain was adjusted to give about full scale deflections (roughly 16 mm measured on the film record of the shot) for the bang from 30 mg of PETN, struck from 300 cm. Under these circumstances a similar blow on a 20 mg sugar sample gave a "weight-noise" deflection of about 0.6 mm measured on the film. For convenience in making "up and down" tests, the rectified output from the amplifier was also introduced into a trigger circuit which differentiated between an "explosion" and an "inert". The pulse from the amplifier-rectifier was introduced in such a fashion as to make the grid voltage of an 884 thyratron more positive. The fixed bias was set enough negative so that the pulse induced by the weight-noise alone would just fail to fire the thyratron. When an explosion occurred the thyratron fired, and a neon tube lit up. This indicating light could be turned off and the circuit reset with a reset switch.

C. NOL Developments

The Bruceton explosion indicator was never completely adapted as a routine indicating device for impact machine tests. When NOL inherited part of the high explosives operations of the ERL, the problem of a simple impact machine indicator to replace the human ear was reconsidered. Electronically the Bruceton indicator had an excess of circuit components. It also was not considered to be as free from sources of variation as might be desired. As a consequence a modified noise indicator was developed for use here, reference (c), (see Appendix 1 of this report.)

Advantage was taken of the wartime experience in the development of piezoelectric gages and circuits for measuring blast pressure in air and under water. As in air blast gages, the crystal microphone was treated as a pressure measuring device. It was coupled into an

amplifier followed by a thyatron without using a signal rectification circuit. (The latter was a complication in the Bruceton detector which was really unnecessary for the measurement of peak amplitude of an explosion. At Bruceton rectification was used to arrive at the envelope of the complex frequency-time relation resulting from reflections of the initial sound pulse on the walls of the room.) The thyatron was triggered when the positive signal resulting from a positive pressure pulse exceeded a given preset level.

The NOL indicator has used another idea borrowed from air blast instrumentation. This is the Q-cal.\* method of establishing the reference loudness. By this method of presetting the noise indicator all circuit elements except the microphone are corrected to a desired signal level. Thus, the effect of changes in amplifiers are minimized and a given microphone located at a given position in a room with the impact machine should give the same results with any noise indicator amplifier to which it might be connected. Two microphones can easily be calibrated relative to each other for the same reason. The NOL noise indicator has proven its reliability and reproducibility over several years of use. About four years ago a barium titanate ceramic microphone was substituted for the Rochelle salt crystal originally used. With the change in microphone, a study found in reference (d) was undertaken to establish the necessary change in padding capacitance necessary to calibrate the system in such a manner that the results obtained in all subsequent work would be in agreement with previous data.

With the grosser aspects, at any rate, of the interpretation problem solved by the electronic noise indicator it has seemed proper to review the selection of the "cut-off" separating results named "explosions" and "inerts" as given in reference (c).

Five different explosives were tested in four successive group tests at four gains lower than one necessary to trigger the meter on inert materials of 35 mg from 320 cm drops. It will be noted in Table 2

-----  
\*Q-cal gets its name from the fact that the coulombs of charge,  $q$  equal to current times time, produced by the crystal microphone when subjected to a bang is calibrated by a capacitor network which can dump a comparable calibrating charge into the input circuit. A millivolt meter has been used to measure the charging voltage on the calibrating capacitor;  $q$  equals capacity times voltage on a capacitor. Since the capacity is fixed for a given set-up it has become habitual for workers using the noise indicator to refer to this charging voltage rather than the number of coulombs of charge used in the calibration.

CONFIDENTIAL  
NAVORD Report 3592

Table 2

Dependence of Fifty Percent Point On  
Noise Indicator Gain

Gain in Millivolts (mv)

Explosive	$\frac{20 \text{ mv}}{h}$		$\frac{40 \text{ mv}}{h}$		$\frac{60 \text{ mv}}{h}$		$\frac{80 \text{ mv}}{h}$	
	m	h	m	h	m	h	m	h
PETN	1.147	(14.0)	1.119	(13.1)	1.079	(12.0)	1.105	(12.7)
Tetryl	1.425	(26.6)	1.367	(23.3)	1.605	(40.3)	1.607	(40.5)
Comp B	1.691	(49.1)	1.703	(50.5)	1.815	(65.3)	1.830	(67.6)
HBX	1.855	(71.6)	1.911	(81.5)	2.023	(106)	2.084	(121)
TNT	1.965	(92.3)	2.068	(117)	2.255	(180)	2.319	(208)

that the PETN value is independent of the gain over this range while each of the other materials shows a rather considerable and fairly regular increase in 50% height with decreasing gain (i.e. increasing in millivolts). The data illustrated in Table 2 plus a desire to match roughly the ERL values affected our decision to set the gain so that the 50% height for TNT would be about 175 cm. A gain value of 50 mv produces this result and has therefore been uniformly employed in all work to date.

#### D. Closed Chamber Testing

A frequent recommendation offered by many people is the use of a closed chamber design wherein the volume of gas produced by an explosion, rather than the noise, would be utilized as a measure of the violence or extent of reaction. Rather than enter a discussion of the general features of the chamber itself, let us observe the merits of such a system together with some of the difficulties encountered.

In Table 3 are recorded the average volumes of gas produced in 10 shots at each height for the several explosives investigated. We note, first of all, that the usual 50% point for PETN (12 cm) corresponds to about 4 cc of gas. Since, normally, only half the shots at this height are considered explosions, on the average each explosion produces only 8 cc or about 25% of the calculated amount of gas which would be produced by the complete conversion of 35 mg of PETN to nitrogen, water vapor, carbon monoxide, carbon dioxide in the stoichiometric quantities. In the case of PETN, particularly, we have generally believed that a single test would result in an obvious inert or in a rather violent explosion.

In the second place, one would expect that, expressed in percentage, the amount of gas produced would vary more rapidly with height than would the percent explosions. That is, the percent explosions is a reasonably definite function of the height, but, in addition, one would expect that the amount of gas produced by each explosion would increase with height or, at worst, be invariant. Superposition of these two effects leads one to expect that the percent gas evolved would increase more rapidly than the percent explosions, or, at worst, the same rate. In Table 3 we presented data of the gas volume evolved vs. the height for each explosive tested. Using the largest observed volume, 23.8 cc, as the maximum available volume under the test, we can calculate the percent gas evolved for each height. If we plot the percentage of gas evolved vs. the drop height in log units on probability paper the curve described by the data does not appear unreasonable. But, when

CONFIDENTIAL  
NAVORD Report 3592

Table 3

Volumes of Gas in cc Produced vs. Height  
Average of 10 Shots

Explosive:	PETN*	RDX	Comp B	HBX	Comp A	TNT
Height (cm)						
8	1.12	0.46	----	----	----	----
12.5	3.58	0.42	----	----	0.64	----
20	6.63	2.26	0.56	0.14	1.13	----
32	11.55	8.23	1.84	0.54	2.15	----
50.5	14.79	11.16	4.62	2.25	5.52	0.66
80.5	16.77	16.65	12.64	4.91	10.08	1.16
127.5	19.45	19.28	18.00	15.55	13.02	2.00
202	21.53	21.28	20.00	16.99	16.58	8.11
320	----	20.25	19.70	17.73	14.89	12.82

\*Subtract 1 cm from each height for PETN

$\sigma$  is calculated from this curve, a value of 0.5 log units is obtained which is four times the  $\sigma$  obtained with the noisemeter.

The introduction of some additional data provides a very simple explanation of these apparent difficulties. In Table 4 are given the volumes of gas produced by 25 shots of PETN at each of two heights, 11.5 and 31 cm. These data are expressed in terms of frequency vs. volume, reduced to groups of 1 cc centered about the mean. The results are shown in Table 5.

The data indicate very clearly that at 11.5 cm, the overwhelming probability is that the sample will fail to explode, with 1 cc or less gas being formed, or will explode with the formation of at least four (generally 5 or 6) cc of gas. At 31 cm, however, the probability of an explosion, as judged by noisemeter or ear, exceeds 0.999 whereas the average volume of gas produced depends only on the height and not on the probability of an explosion, which is essentially constant and equal to one. Thus these two distributions are not superposed except over a very short region. It appears from the data that a similar situation very likely exists in the case of RDX and may exist even for some of the less sensitive materials. Considering the greater time required per shot with the closed chamber, this procedure does not seem to offer any great advantage from the standpoint of precision in the case of PETN, at least, though further refinements in apparatus and technique could improve the time factor considerably. The level of gas evolution to be used to compare explosives also is not easy to decide upon in the case of the closed chamber method as applied to the type 12 machine. Indeed, the basis on which to make the comparison is not clear.

#### Miscellaneous Studies

##### A. Effect of Pressure on Impact Samples

One of the factors frequently discussed in impact testing is the sample presented for test. We have previously discussed the effect of sample weight and the question of conditioning of the sample was neglected. If the sample presented for test is consistent in surface area presented for impact, through the use of pelleting (either cast or pressed depending on the use of the material), one might expect a greater reproducibility from explosive to explosive and from one sample of the same explosive to another. To investigate this possibility a series of samples were prepared using 35 mg samples pressed in a 0.2" diameter mold using various pressures. The results in Table 6 show that although the variables of particle size, sample weight and sample shape were controlled, no real advantage in the use of these pellets is indicated. However, before such a statement

CONFIDENTIAL  
 NAVORD Report 3592

Table 4

Volumes of Gas Produced in Successive Tests at 11.5 and 31 cm

PETN - 35 mg Samples

	<u>11.5 cm</u>		<u>31 cm</u>
5.8 cc	0.6	10.1 cc	7.5
4.5	5.5	12.7	10.4
6.6	1.0	10.9	12.8
0.8	4.7	11.2	11.1
1.0	0.2	11.0	9.5
5.3	0.0	11.8	12.5
6.1	0.1	10.0	15.1
4.0	0.7	11.5	12.3
0.7	5.7	11.1	10.0
6.2	5.0	9.5	10.0
0.5	5.9	10.5	9.9
0.2	0.0	11.8	12.7
5.8	---	11.1	----
	Ave. 3.1		Ave. 11.1

Table 5

Frequency vs. Volume (from Table 4)

<u>Volume</u>	<u>11.5 cm</u>	<u>Volume</u>	<u>31 cm</u>
	<u>No. of Occurrences</u>		<u>No. of Occurrences</u>
0.1 ± 0.5	6 1/2	7.1 ± 0.5	1
1.1	5 1/2	8.1	0
2.1	0	9.1	2
3.1 (mean)	0	10.1	7
4.1	2	11.1 (mean)	7
5.1	4	12.1	4
6.1	6 1/2	13.1	3
7.1	1/2	14.1	0
		15.1	1

CONFIDENTIAL  
NAVCOR Report 3592

Table 6

Effect of Pressure vs. Sensitivity

Explosive	Loading Pressure	TOWER # 1*			TOWER # 2*		
		n	50% Ht(cm)	$\sigma$	n	50% Ht(cm)	$\sigma$
Tetryl	Bulk	1.52	33	0.17	1.49	31	0.11
"	8,000#	1.43	27	0.08	1.64	43	0.35
"	16,000#	1.42	26	0.03	1.59	39	0.26
"	32,000#	1.41	26	0.07	1.70	50	0.50
Comp A-3	Bulk	1.95	88	0.06	1.95	88	0.12
		1.76	58	0.07	1.96	90	0.10
		1.81	64	0.18	2.09	123	0.11
"	8,000#	1.94	87	0.13	1.94	86	0.08
		1.81	64	0.25	2.06	115	0.10
"	16,000#	1.83	68	0.09	1.80	63	0.34
		1.74	56	0.13	2.08	119	0.13
"	32,000#	1.94	86	0.13	1.80	63	0.23
TNT	Bulk#	2.24	175	0.29	2.23	170	0.19
"	8,000#	2.04	109	0.50	2.21	163	0.10
"	16,000#	2.03	108	0.50	2.13	136	0.27
"	32,000#	2.10	126	0.25	2.14	138	0.18

-----  
\*Towers 1 and 2 refer to the two impact machines at NOL.

is made, a study of the effects of density, height to diameter ratio, and sample weight on the pellet should be made, to better understand the behavior of each explosive in this new form.

B. Replacement of Sandpaper by Glass Cloth

One of the disadvantages in the present impact machine is the effect of sandpaper on oxidizing materials. One possibility for replacing sandpaper is glass cloth. Immediately available were samples of glass cloth in rolls of 1/2" and 3/8" widths. A limited number of samples were tested using these two widths of glass cloth, and included both oxygen rich and oxygen deficient materials. The sensitivity of ammonium perchlorate given in Table 7 illustrates the advantage of the glass cloth. The sensitivity of ammonium perchlorate with sandpaper is 44 cm. Tests of ammonium perchlorate without sandpaper give a sensitivity of 101 cm. No change in sensitivity is observed for the other explosives tested. However, the fine glass fibres which filled the air upon explosion, irritated the skin of the operators to such an extent that the experiment was abandoned.

C. Kinetic vs. Potential Energy

If one is interested in a drop weight test as a means for determining only the relative sensitivities of a group of explosives, then any machine which gives a so-called satisfactory order of sensitivity will suffice. We have seen that there are many machines that fulfill this requirement. However, when any attempt is made to compare the results of one machine with another, a lack of knowledge on our part of the controlling factors makes correlation of these results almost impossible. This lack of understanding results from the use of different drop weights, tools, sample weights, etc. One of the considerations for a uniform method of reporting data is the use of energy. Certainly, a comparison of energy necessary to produce a given explosive efficiency would be a common denominator for all machines.

If one considers the use of energy in reporting data, he must further clarify the situation by considering the individual machine. As a step in this direction, we have undertaken a study to determine the amount of energy available for test purposes by considering the loss of energy in the particular system we employ. We note first of all that the coefficient of restitution of the machine varies with the drop height. We have attempted to present in Table 8 one part of the reduction to a uniform method of reporting.

CONFIDENTIAL  
NAVORD Report 3592

Table 7

Glass Cloth as a Replacement for Sandpaper

Explosive	TOWER # 1			TOWER #2		
	m	50% Ht (cm)	$\sigma$	m	50% Ht (cm)	$\sigma$
BTNEN (1/2" glass cloth)	0.89	8	0.11	0.86	7	0.18
BTNEN (3/8" glass cloth)	0.95	9	0.22	0.92	8	0.07
TNETB (1/2" glass cloth)	1.31	20	0.07	1.18	15	0.09
TNETB (3/8" glass cloth)	1.31	20	0.10	1.18	15	0.09
NH <sub>4</sub> ClO <sub>4</sub> (thru 20 mesh)						
NH <sub>4</sub> ClO <sub>4</sub> (1/2" glass cloth)	1.97	94	0.09	2.02	105	0.12
NH <sub>4</sub> ClO <sub>4</sub> (3/8" glass cloth)	1.89	78	0.12	1.89	79	0.07
RDX (1/2" glass cloth)	1.37	23	0.22	1.28	19	0.14
RDX (3/8" glass cloth)	1.37	23	0.09	1.31	21	0.18
TWT (1/2" glass cloth)	2.32	209	0.03	2.38	240	0.09
TWT (3/8" glass cloth)	2.39	246	0.08	2.47	296	0.10

Table 8

Comparison of Potential and Kinetic Energies Available on Impact

Drop Height (cm)	Rebound Height (cm)	% Energy Lost to Machine	(Potential) Initial Energy (kg cm)	(Kinetic) Available Energy (kg cm)
320	218	32	800.0	544.0
202	133	35	505.0	328.2
127.5	82	38	318.7	197.6
80.5	47	42	201.2	116.7
50.5	28	45	126.2	69.4
32	16	50	80.0	40.0
20	8	60	50.0	20.0
12.5	3	76	31.2	7.5
8	2	75	20.0	5.0
5	1	80	12.5	2.5

CONFIDENTIAL  
NAVORD Report 3592

Conclusion

The data presented in this report have served as a basis for making decisions applying to the method of testing employed at NOL. In view of the increasing number of drop weight impact machines which are duplicates of the NOL machine, the data in this report may serve as a guide for other activities in determining sources of variation in data. Certainly if there is any thought of duplicating values obtained by NOL, we must consider a standardization of technique. This in itself is not sufficient for duplication of data. For example, in the "electronic noise indicator", the millivolt setting depends on the padding capacity, microphone output and microphone placement. Since the sensitivities of various explosives at various millivolt settings are known, it is possible to obtain duplicate drop heights by changing the millivolt settings in one machine to correspond with sensitivities of a second machine at a different millivolt setting.

One additional source of variation which can be easily checked is the polarity of the microphone itself. Since in the amplification of the signal, the phase is changed twice, a positive voltage must come from the microphone through the phase changes and into the thyratron to trigger the neon light. If the voltage from the microphone is negative a system of reduced sensitivity would probably result or else the thyratron would never be triggered.

*George Svadera*  
GEORGE SVADEBA

APPENDIX 1\*

The Electronic Noise Indicator for the Impact Machine

S. J. Jacobs

The noise indicator or "noisemeter", as this device is usually called, is a device which gives a visual signal to indicate whether a given noise from the impact test is above or below a given reference level. The instrument uses a piezoelectric microphone (Rochelle salt type) essentially as a peak pressure device. The pressure signal incident on the microphone produces a charge on the microphone which, within the frequency limits of the microphone, is proportional to the pressure. This charge produces a voltage which is proportional to the charge across the capacitance of the microphone, a padding capacitor used for calibration, and the associated input circuit capacitance. The voltage is amplified so that an output of about 40 volts is obtained to correspond to the voltage produced by the microphone at the desired reference level. The amplified voltage is used to trigger a small thyratron biased to about 40 volts below the triggering voltage. Triggering the thyratron causes a neon glow lamp to light, thus indicating that the peak sound level actuating the microphone exceeded the reference level selected. A sound level below the reference level fails to trigger the thyratron and so fails to light the neon indicator lamp. The circuit is arranged so that the only variable not under the control of the operator is the response of the microphone. This response may be a function of the ambient temperature.(1) Operational control is achieved by introducing the calibrating signal at the input of the amplifier. The calibrating signal is introduced as a Q calibration(2) (Q = quantity of charge) which then calibrates the instrument for microphone output independent of capacity in the microphone circuit. Triggering at the desired level is accomplished by adjusting the amplifier gain. The method

-----  
(1) Recently two types of crystal mikes having low temperature coefficients have been commercially introduced. One uses ammonium dihydrogen phosphate, the other a ceramic of barium titanate. Either type in this application might need an additional amplification stage.

(2) For more details of the Q calibration see page 6.

-----  
\*Reprinted from NOLM 10,003

APPENDIX 1

of calibrating is described in reference (c). The schematic of the instrument and the list of parts is shown in Figure 1. The microphone used was an Astatic, Model N-30. The leads to the crystal had to be reversed to supply the proper signal polarity for operating the thyatron through the three stage amplifier. It might have been more desirable to have added an additional phase inverter stage preceding the thyatron. This could be easily accomplished as a cathode-follower, plate follower so that either polarity of input signal could be handled. If that were done provision would also have to be made to invert the voltage of the calibrator signal. Almost any other type of crystal microphone could be used in place of the N-30. It would be most desirable to use a microphone with as large an upper frequency limit as possible; 10 to 15 KC is now commercially available. The frequency limit of the N-30 microphone is probably about 6 KC. It was thought that this limit was still superior to the effective response limit of the human ear.

The functional parts of the instrument are indicated in the following block diagram:

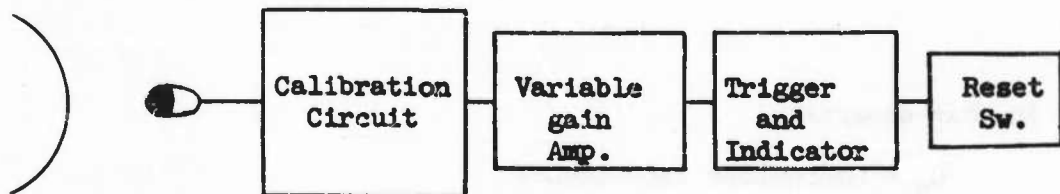

Functional Parts of Electronic Noise Indicator  
Figure 2.

APPENDIX 1

The Q Calibration:

The equivalent circuit for the microphone and input calibration is shown in Figure 3.

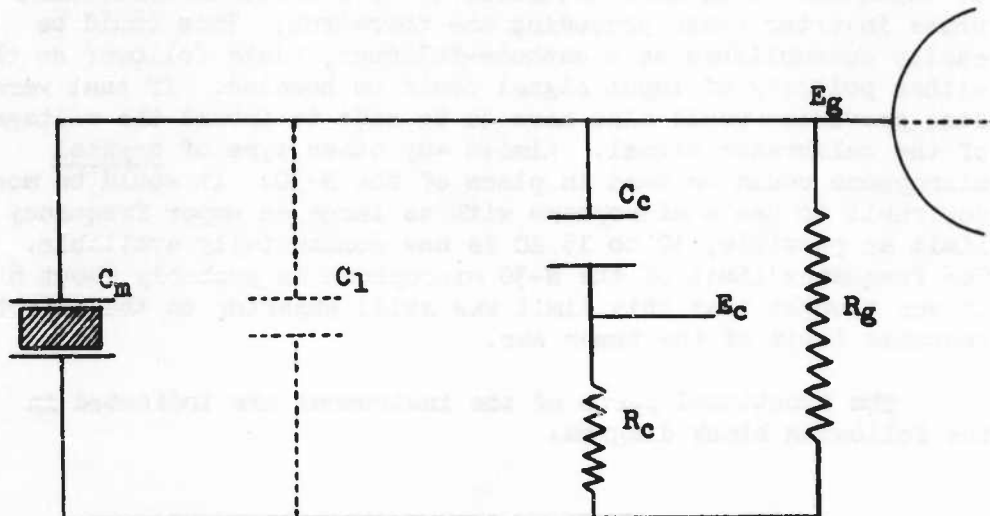

Figure 3. Equivalent Input Circuit

In this diagram:

$C_m$  = microphone capacitance

$C_1$  = line and stray circuit capacitance

$C_c$  = calibration capacitance ( $C_m + C_1$ )

$R_c$  = resistor across which calibration voltage  $E_c$  is developed

$R_g$  = grid resistor

CONFIDENTIAL  
NAVORD Report 3592

APPENDIX 1

$E_g$  = voltage input to amplifier

$E_c$  = calibration voltage

$Q$  = charge developed by microphone for a given acting pressure,  $p$

The microphone may be considered as a charge generator in parallel with a capacitance,  $C_m$ . When a pressure acts on the microphone the charge developed is:

$$Q = K A p$$

If  $p = p(\text{time})$  then  $Q(t)$  is a linear function of  $p(t)$  within the limits of the linear response range of the microphone.  $K$  is the piezoelectric constant and  $A$  is the gage area.  $K$  is a function of temperature but in this application the temperature coefficient seems small enough to be neglected for the ambient range normally encountered\*.

The voltage,  $E_g$ , developed by the sound pressure  $p$  is:

$$E_{g'm} = \frac{K A p}{C_m + C_1 + C_c}$$

(In this equation  $E_c$  is zero and the effect of  $R_c$  and  $R_g$  may be neglected because  $R_c$  is very small and  $R_g$  is very large.)

For calibration; a voltage,  $E_c$ , is applied as a square step by switching a constant current through  $R_c$ . Then:

$$E_{gc} = E_c \frac{\frac{1}{C_m + C_1}}{\frac{1}{C_c} + \frac{1}{C_m + C_1}}$$

-----  
\* In this connection it might be stated that Rochelle salt is far from an ideal material for the microphone because it has a Curie point at 24°C. If more precision were desired it would be well to investigate other P.E. materials such as ADP or tourmaline.

CONFIDENTIAL  
 NAVORD Report 3592

APPENDIX 1

or

$$E_{gc} = E_c \frac{C_c}{C_m - C_l + C_c}$$

In operation a standard capacitance  $C_c$  is plugged into the calibrator,  $E_c$  is selected and the gain is set so the instrument just triggers when  $E_c$  is switched in. This then establishes a minimum level for triggering by the microphone given by:

$$E_{gm} = E_{gc}$$

Then:

$$P_{trigger} = \frac{E_c C_c}{K A}$$

In this equation all circuit variables have been eliminated except the calibrating voltage and capacity. It is thus possible to reproduce trigger settings independent of variation of microphone cable length or variation of microphone capacitance.\*

-----  
 \*There is some evidence that the change of capacitance of a Rochelle salt crystal somewhat parallels its change of piezoelectric constant. This would make a Q calibration less satisfactory than a voltage calibration for this type of microphone. Actual tests with the impact machine over a rather wide range of ambient temperature have indicated satisfactory agreement of 50% points however. An idea of the probable magnitude of the temperature effect on the Rochelle salt microphone may be gained from some data in NOLM 5125 on a Brush Hydrophone. This showed the following response (approximately), at 30 and 150 cycles as a function of T.

T, °F	Response, microvolts/bar (dyne/cm <sup>2</sup> )
50	100
70	130
74	155 (max)
90	125
100	120

CONFIDENTIAL  
NAVORD Report 3592

APPENDIX 1

Notes on Operation:

1. It should be noted that the calibrated level for triggering is proportional to  $E_c C_c$  and not just  $E_c$ . However, after selecting a given value of  $C_c$ ,  $E_c$  then naturally is a measure of the trigger level.

2. The meter marked M.V. on the schematic is fundamentally an 0-1 milliamperemeter. It is used with a 3 position switch, Sw2. In switch position 1 it shows  $E_c$  across a 10 ohm resistor and therefore gives a range of  $E_c$  from 0 to 10 millivolts. In switch position 2,  $E_c$  is across a 100 ohm resistor and the meter then reads a range of  $E_c$  from 0 to 100 millivolts. In switch position 3 the meter is a 0 to 100 voltmeter used to measure the voltage on the cathode of V4 for adjusting the thyratron bias.

Acknowledgement:

The assistance of J. E. Coumihan in constructing and testing of the noise meter is gratefully acknowledged.

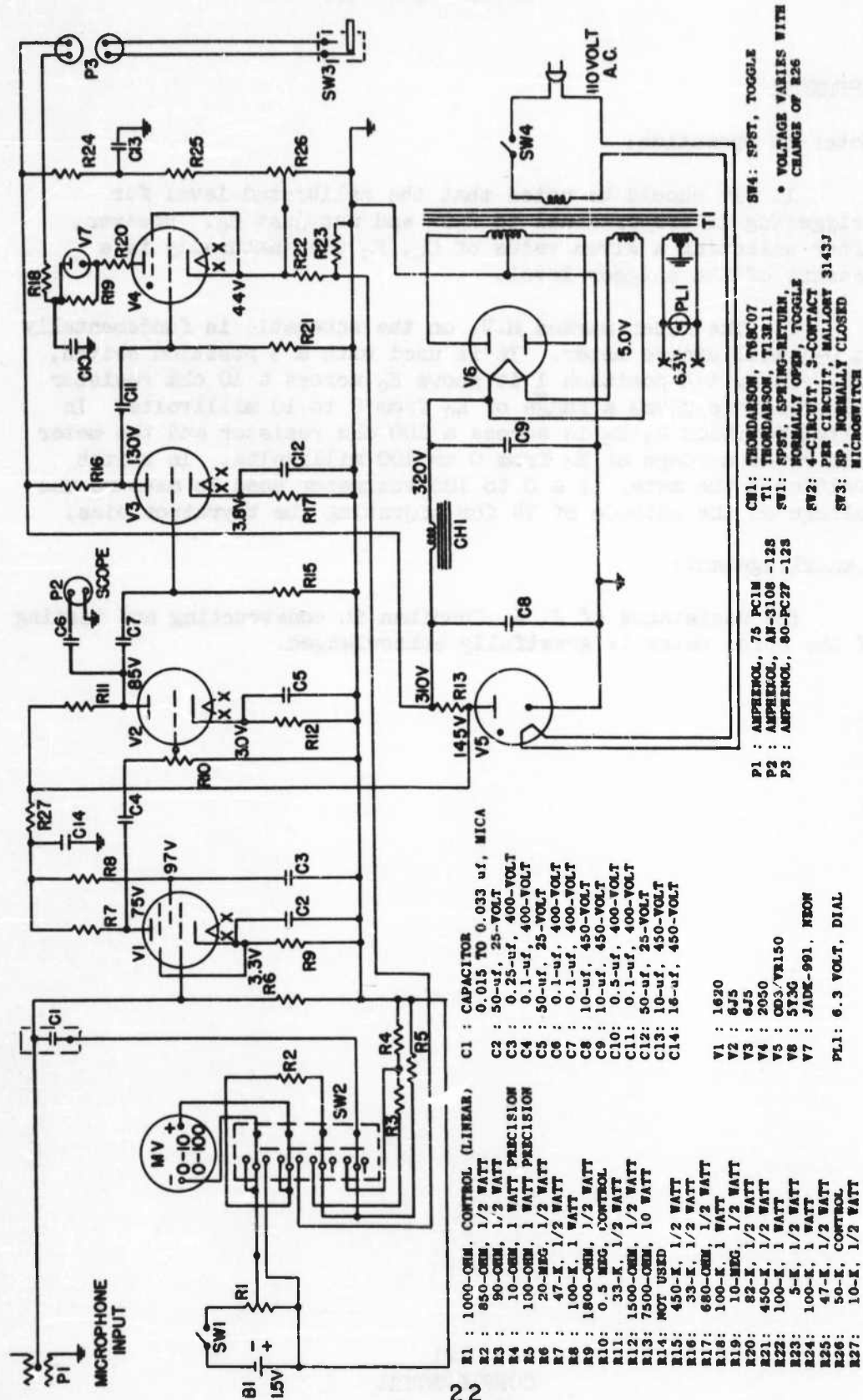

APPENDIX I  
FIG.1 NOISE INDICATOR FOR IMPACT MACHINE (FROM NOL SKB-67695)

References

- (a) OSRD 5744, Physical Testing of Explosives, Part II, 27 December 1945, E.H. Eyster, R.F. Davis
- (b) AMP Report No. 101.1R, Statistical Analysis for a New Procedure in Sensitivity Experiments
- (c) NOLM 10,003, Studies of the ERL Type Drop Weight Impact Machine at NOL, 25 January 1949, E.H. Eyster, L.C. Smith
- (d) NavOrd Report 1589, Impact Sensitivity Determinations of Explosive Compounds Tested During the Period from 1 January 1950 to 1 November 1950, N.D. Mason

~~CONFIDENTIAL~~

Distribution

Chief, Bureau of Ordnance, (Re2b), Wash., D.C.	2 copies
Chief, Bureau of Ordnance, (Re2c), Wash., D.C.	6 copies
Chief, Bureau of Ordnance, AdB, for distribution as follows:	
British Joint Services Mission	5 copies
Defense Research Member Canadian Joint Staff, Wash., D.C.	2 copies
U.S. Naval Attache, London, England	3 copie
Chief, Bureau of Aeronautics, Wash., D.C.	2 copies
Chief, Naval Operations, Wash., D.C.	2 copies
Chief of Ordnance, Department of the Army, Research and Development Division, Wash., D.C., Attention ORDTQ	4 copies
Office, Chief of Ordnance, Department of the Army, Wash., D.C.	
Attention ORDTA - Dr. L. R. Littleton	1 copy
Chief, Bureau of Ships, Wash., D.C.	1 copy
Chief, Naval Research, Navy Department, Wash., D.C. Attention Code 466	3 copies
Commanding Officer, Naval Mine Depot, Yorktown, Va.	3 copies
Commanding Officer, Naval Mine Depot, Yorktown, Va., Attention R&D Division	1 copy
Commander, Naval Proving Ground, Dahlgren, Va.	2 copies
Commander, Naval Ordnance Test Station, Inyokern, Calif.	3 copies
Commander, Naval Ordnance Test Station, Inyokern, Calif., Attention Dr. R.W. Van Dolah	1 copy
Commanding Officer, Naval Powder Factory, Indian Head, Md.	4 copies
Commanding General, Air Material Test Center, Eglin Air Force Base, Fla.	1 copy
Commanding Officer, Norfolk Naval Shipyard, Portsmouth, Va.	1 copy
Commanding Officer, Picatinny Arsenal, Dover, N.J.	3 copies
Commanding Officer, U.S. Army, Redstone Arsenal, Huntsville, Ala.	2 copies
Commanding General, Ordnance Ammunition Center, U.S. Army, Attention ORDLY-R, Joliet, Ill.	1 copy
Director, Ballistic Research Laboratories, Aberdeen, Md.	2 copies
Director, Naval Research Laboratory, Wash., 25, D.C. Attention Dr. Zisman	1 copy
Attention Dr. Fox	1 copy
A.D. Little Inc., Cambridge 42, Mass., via InsMat Attention Dr. W.C. Lothrop	1 copy
Armour Research Foundation, Research Center, Chicago, Ill., via InsMat Attention Dr. W.C. McCrone	1 copy

~~CONFIDENTIAL~~

Distribution

Los Alamos Scientific Laboratory, Los Alamos, N.M., via  
InsMat  
Attention Dr. D.P. MacDougall 1 copy  
Attention Dr. L. C. Smith 1 copy  
Hercules Powder Co., Wilmington 99, Delaware via InsMat  
Attention Dr. Julius Roth 1 copy  
Solid Propellant Information Agency, Applied Physics  
Laboratory, Johns Hopkins University, Silver Spring,  
Md., via InsOrd 2 copies  
Quality Evaluation Laboratory, Army Ammunition Depot,  
Oahu, T.H. c/o Postmaster, San Francisco, Navy #66 1 copy  
Quality Evaluation Laboratory, U.S. Navy Ammunition  
Depot, Crane, Indiana  
Attention Mr. J.C. DeVault 1 copy  
Attention Mr. D.J. Hale 1 copy