

Armed Services Technical Information Agency

Because of our limited supply, you are requested to return this copy **WHEN IT HAS SERVED YOUR PURPOSE** so that it may be made available to other requesters. Your cooperation will be appreciated.

AD

41545

NOTICE: WHEN GOVERNMENT OR OTHER DRAWINGS, SPECIFICATIONS OR OTHER DATA ARE USED FOR ANY PURPOSE OTHER THAN IN CONNECTION WITH A DEFINITELY RELATED GOVERNMENT PROCUREMENT OPERATION, THE U. S. GOVERNMENT THEREBY INCURS NO RESPONSIBILITY, NOR ANY OBLIGATION WHATSOEVER; AND THE FACT THAT THE GOVERNMENT MAY HAVE FORMULATED, FURNISHED, OR IN ANY WAY SUPPLIED THE SAID DRAWINGS, SPECIFICATIONS, OR OTHER DATA IS NOT TO BE REGARDED BY IMPLICATION OR OTHERWISE AS IN ANY MANNER LICENSING THE HOLDER OR ANY OTHER PERSON OR CORPORATION, OR CONVEYING ANY RIGHTS OR PERMISSION TO MANUFACTURE, USE OR SELL ANY PATENTED INVENTION THAT MAY IN ANY WAY BE RELATED THERETO.

Reproduced by
DOCUMENT SERVICE CENTER
KNOTT BUILDING, DAYTON, 2, OHIO

UNCLASSIFIED

AD No. 41545

ADIA FILE COPY

INTERM DEVELOPMENT REPORT

FOR

A LINE OF ANTENNA MATCHING TRANSFORMERS

This report covers the period of January, 1954
to March, 1954

Contractor

Westinghouse Electric Corporation

2519 Wilkens Avenue

Baltimore, Maryland

NAVY DEPARTMENT BUREAU OF SHIPS
ELECTRONICS DIVISIONS

Index Number NE-110915, Attention Code 327
WG 69540 K Nobsr 63020

FURTHER DISSEMINATION IS AUTHORIZED ONLY TO
MILITARY AGENCIES.

QUARTERLY REPORT

WG - 69540

Antenna Matching Transformers

Engineering effort during the first quarter of 1954 has all been spent on the Type II unit. The primary side of this transformer connects to a 600 ohm balanced line. The secondary side connects to load impedances of 25 to 225 ohms, with no change in transformer turns ratio. Rated power is 3 KW, 100% modulated. Three transformers have been tested as follows:

- A. This transformer had four ferrite cores with a total core area of 1.26 sq. inches. Material was Stackpole Ceramag 2280, which is a nickel zinc ferrite of low permeability. The windings at twenty-four turns total in the primary and six turns in the secondary. Both windings were half on one leg of the core and half on the other, connected in the style known as "Hum-bucking", as shown in Fig. 1. This transformer had reasonable core temperature rise over the frequency range of 2.5 to 7.5 mc, but copper loss was excessive at 7.5 mc. Also it was discovered that the windings were not balanced over this frequency range. Therefore, we rewound this transformer, with a larger number of secondary turns on each leg, and connected the windings in parallel. This required that the secondary turns on one leg be wound in opposite direction to those on the other. Now balance was achieved within much better limits, but winding capacitance increased, so that this transformer did not perform as well with the balanced connection.

That is to say, the temperature rise was still greater at the 7.5 mc end of the frequency range.

B. In order to meet the requirements that the transformer operate into an impedance range of 25 to 225 ohms, we decided next to use a larger core. This seemed advisable because at the higher impedance, higher voltage would be necessary, and the core loss would increase to a prohibitive value unless a larger core was used. The core was of the square shape as shown in Figure I, but the core area was 1.89 sq. inches in the unit designated here as B. The windings were also increased in area to accommodate the lower value of impedance. The transformer had size corresponding to nine KW rather than three because of the range in output impedance values. The transformer was first wound on Ferramic A core material which was believed to be similar in composition to that of transformer A. The windings were wound in balanced fashion but with the secondary split into two windings on each leg. With the primary sandwiched between the two secondary windings, the leakage inductance was reduced, but the capacitance was increased. This transformer performed well at 2.5 mc and has acceptable temperature rise at impedances of 33 and 75 ohms, but not at 200 ohms. At that impedance, the core temperature rise was sufficient to reach the Curie point and demagnetize the core. 33 and 200 ohms were the nearest impedance values to 25 and 225 ohms, respectively, which could be made up from laboratory resistors.

C. A transformer was then made with the same size core and windings as B, but with Ferramic G core material. Ferramic G has approximately the same core loss per cu. in. as A, but has much higher permeability. It was hoped that the tighter coupling would improve the frequency response, but tests indicated that the core temperature rise was still too high at 4.5 mc. It was apparent that the four secondary part-windings did not load up equally and therefore the load was divided between them, see Figure 2. Impedance measurements showed the winding capacitance was greater than had been expected from design calculations.

In an effort to reduce the capacitance of this transformer we removed the outer secondary windings on each leg and again ran the transformer at three load impedances of 33 ohms, 75 ohms and 200 ohms. Performance was substantially the same as before at the two lower impedances, and a longer time was required for the core to overheat. But overheating did occur and caused the core to lose magnetization as in the previous transformer. Calculations showed that very little improvement could be expected from different winding arrangements or combinations of transformers so long as the core material had the same loss and Curie point. There is an approximate relation between the length of wire in the primary winding and the highest frequency at which the transformer must operate. We have exceeded this limit in the larger transformer at 7.5 mc. It therefore appears that transformer A is the best design so far, but there was not

sufficient time to discover the reason for high winding temperature at 7.5 mc. The major advantage to be derived from further work on this transformer lies in the smaller dimensions which result in a higher maximum operating frequency.

Because of the excessive temperature rise on these transformers, no tests were made at 100% modulation. Detailed results for all 3 transformers are given in the following tables. Where 2 values are given for primary current and voltage these values are for each side of the center tap. The differences in value indicate the extent of unbalance.

Ferramic Q cores are now on hand. These cores have about 1/2 the loss of Ferramic A. It is planned to test these cores with fewer turns than transformer A in order to extend the frequency range.

Transformer A with 24/8 turns
not balanced.

	Load (DCR)	Quantity	4.0 to 4.46 MC	8.0 MC	
Primary	33 ohms	amps	2.41 to 2.55	1.0 to 1.73	
		volts	780 + 810	275 + 2300	
		VA	3940	3520	
			Input Z	641	1888
		(3KVA) Temp. Rise	97 C°	175 C°	
	82 ohms	amps	1.70 to 1.75	1.25 to 1.45	
		volts	795 + 840	210 + 1850	
		VA	2820	2780	
			Input Z	948	1526
		(3KVA) Temp. Rise	41 C°	177 C°	
	200 ohms	amps	1.37 + 1.45	1.81 + 2.12	
		volts	1080 + 1180	175 + 1600	
		VA	3190	2980	
			Input Z	1605	952
		(3 KVA) Temp. Rise	37 C°	132 C°	
open circuit	amps	0.65 + 0.95			
	volts	1140 + 1270			
	VA	1880			
short circuit	Input Z	3090			
	amps	4.1 + 4.18			
	volts	685 + 725			
	VA	5840			
	Input Z	341			
Secondary	33 ohms	amps	9.1	6.05	
		volts	340	445	
		VA	3095	3670	
		(3KVA) Temp. Rise	96 C°	160 C°	
	82 ohms	amps	5.50	5.85	
		volts	500	500	
		VA	2750	2925	
		(3KVA) Temp. Rise	32 C°	181 C°	
	200 ohms	amps	3.55	3.66	
		volts	750	680	
		VA	2660	2490	
		(3KVA) Temp. Rise	35 C°	128 C°	
		open circuit	Volts	840	
		short circuit	amps	13.9	
	Core	33 ohms (3KVA)	Temp. Rise	45 C°	125 C°
82 ohms (3KVA)		Temp. Rise	21 C°	103 C°	
200 ohms (3KVA)		Temp. Rise	29 C°	57 C°	

Transformer A with 24/6 turns, not balanced.

Temp. Rise measured by thermometer alone
values increased to agree with DCR measurement at 10 MC.

		2.5 MC	4.0 MC	6.0 MC	10 MC	Temp. Rise Measurement changed to DCR - 10 MC
Primary	amps	1.97	2.32	1.7	1.71	1.81
	volts	1555	1235	1570	852	797
	44 ohm load VA	3062	2870	2670	1457	1442
	Input Z (3KVA)Temp. Rise	789	532	924	498	440 71 C°
Secondary	amps	8.0	8.0	8.3	8.8	9.7
	44 ohm load volts	382	382	402	382	389
	VA	3050	3050	3336	3360	3770
	Load Z (3KVA)Temp. Rise	47.7	47.7	48.4	43.4	40.1
core-44 ohm load (3KVA)Temp. Rise	85.4	75.7	67	61	61 C°	

Transformer A as above rewound so as to improve balance 24/6 turns;
2 sec. in each leg and in parallel

		2.5 MC	6.2 MC	8.0 MC	10. MC
Primary	amps	2.0	1.97	2.08	1.22
	44 ohm load volts	1407	1596	1296	1566
	VA	2814	3140	2695	1896
	Input Z (3KVA)Temp. Rise	703.5	810	623.5	1295 1380 C°
Secondary	amps	7.7	7.5	8.0	9.8
	44 ohm load volts	328	407.5	385	315
	VA	2525	3060	3080	3085
	Load Z (3KVA)Temp. Rise	42.7	54.4	48.1	32.1 130 C°
Core 44 ohm load. (3KVA)Temp. Rise	83.5 C°	37 C°	42.5 C°	34 C°	

Transformer B

L-529401 (Ferramic A core material)

		f in MC	
		2.5 MC	8.0 MC
Primary 44 ohm load	amps	2.8	4.7
	volts	1031	668
	VA	2380	3140
	Input Z	368	142
Secondary 44 ohm load (3KVA)	Temp. Rise	110 C°	241 C°
	amps	7.8	8.5
	volts	344	379
	VA	2680	3220
Core 44 ohm load (3KVA)	Temp. Rise	80 C°	120 C°
	Temp. Rise	79 C°	199 C°

Similar transformer to above, but tinned copper channels around cores reduced in size:

Primary 44 ohm load	amps	3.55
	volts	788
	VA	2800
	Input Z	222
Secondary 44ohm load (3KVA)	Temp. Rise	* 684 C°
	amps	8.1
	volts	379
	VA	3070
Core 44 ohm load (3KVA)	Temp. Rise	* 5360 °
	Temp. Rise	* 198 C°

* estimated from 20 minutes of operation; was actual temperature of:
 Pri: 180 C°
 Sec: 143 C°
 Core: 48 C°

4 (sec)		Transformer C		f in MC		
	Load	Quantity	2.5 MC	4.46 MC	8.0 MC	
Primary	33 ohms	amps		2.77		
		volts		515		
		VA		1425 VA		
			Input Z		186 ohms	
			(3KVA) Temp. Rise		53 C°	
	82 ohms	amps	2.40-2.45	2.86-3.02	3.53-3.90	
		volts	655 -670	560 -605	383 -420	
		VA	3210	3420	2980	
			Input Z	546	396	216
			(3KVA) Temp. Rise	54 °C	58 C°	147 C° (91)
	200 ohms	amps		4.1-4.25		
		volts		790 -860		
		VA		1650		
			Input Z	6900		
			(3KVA) Temp. Rise	394.4		
open circuit	amps	1.22-2.5	2.75 - 3.0	1.8-1.9		
	volts	620-630	618 - 845	155		
	VA	2325	4210	2870		
		Input Z	985	508	167.5	
short circuit	amps	1.58-1.62	2.95	1.15-1.46		
	volts	53.5-55.	280-220	140-165		
	VA	173.5	1240	397		
		Input Z	67.8	142.2	234	
Secondary	33 ohms	amps		9.2		
		volts		335		
		VA		3080		
			(3KVA) Temp. Rise		64 C°	
	82 ohms	amps	5.9	5.9	6.0	
		volts	485-500	450-500	390-510	
		VA	2905	2810	2700	
			Temp. Rise	59 C°	62 C°	178C° (111)
	200 ohms	amps		3.68		
		volts		705-760		
		VA		2690		
			(3KVA) Temp. Rise	2.6 C°		
	(Secondary)	open circuit	volts	490-520	525-695	195-250
		short circuit	amps		9.12	
	core	33 ohms	(3KVA) Temp. Rise		27 C°	
82 ohms		(3KVA) Temp. Rise	30.5 C°	35 C°	80 C°	
200 ohms		(3KVA) Temp. Rise		95.5 C° +		

Transformer C

(2 sec)

			f in MC			
			2.5 MC	4.46 MC	8.0 MC	
Primary	33 ohms	amps		2.5 - 2.75		
		volts		670 + 645		
		VA		3450		
	(3KVA)	82 ohms	Input Z		501	
			Temp.Rise		85 C°	
			amps		2.22 - 2.38	
	(3KVA)	200 ohms	volts		605 + 630	
			VA		2840	
			Input Z		537	
	(3KVA)	open circuit	Temp.Rise		84.7 C°	
			amps		2.95 - 3.0	
			volts		770 + 820	
	(3KVA)	short circuit	VA		4730	
			Input Z		535	
			Temp.Rise		115 C°	
Secondary	33 ohms	amps		2.14 - 1.98		
		volts		795 + 915		
		VA		3523		
	(3KVA)	82 ohms	Input Z		930	
			Temp.Rise		269	
			amps		9.1	
	(3KVA)	200 ohms	volts		330-350	
			VA		3090	
			Temp.Rise		109 C°	
	(3KVA)	open circuit	amps		5.9	
			volts		460-490	
			VA		2800	
	(3KVA)	short circuit	Temp.Rise		91 C°	
			amps		3.7	
			volts		715-760	
(3KVA)	Core	VA		2730		
		Temp.Rise		174 C°		
		volts		670-795		
(3KVA)	33 ohms	amps		7.125		
		Temp.Rise		54 C°		
		Temp.Rise		45 C°		
(3KVA)	82 ohms	Temp.Rise		95.1 C°		
		Temp.Rise				
		Temp.Rise				

WESTINGHOUSE ELECTRIC CORPORATION

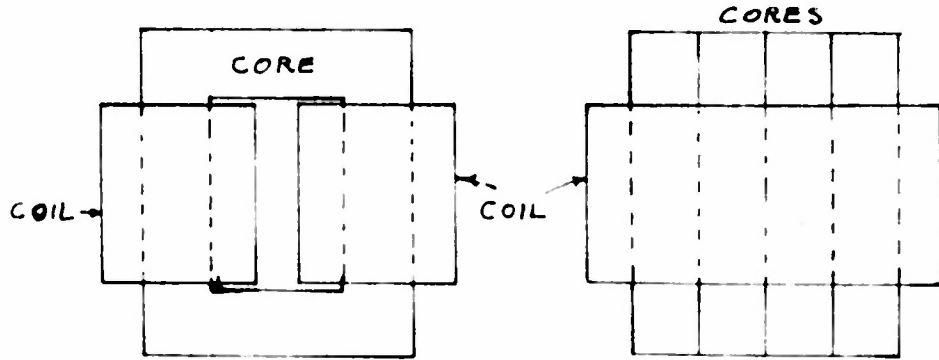

FIG. 1

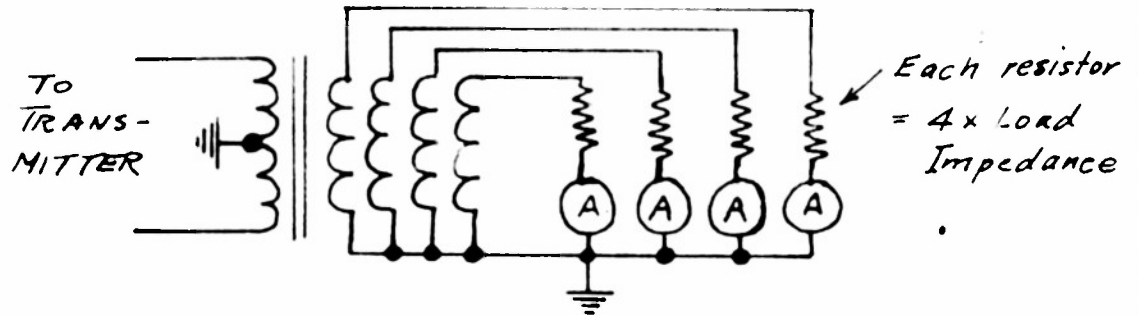

FIGURE 2

CONTRACT NO bsr-63020

INDEX NO. NE-110915

4/5/54

Armed Services Technical Information Agency

Because of our limited supply, you are requested to return this copy WHEN IT HAS SERVED YOUR PURPOSE so that it may be made available to other requesters. Your cooperation will be appreciated.

AD

41545

NOTICE: WHEN GOVERNMENT OR OTHER DRAWINGS, SPECIFICATIONS OR OTHER DATA ARE USED FOR ANY PURPOSE OTHER THAN IN CONNECTION WITH A DEFINITELY RELATED GOVERNMENT PROCUREMENT OPERATION, THE U. S. GOVERNMENT THEREBY INCURS NO RESPONSIBILITY, NOR ANY OBLIGATION WHATSOEVER; AND THE FACT THAT THE GOVERNMENT MAY HAVE FORMULATED, FURNISHED, OR IN ANY WAY SUPPLIED THE SAID DRAWINGS, SPECIFICATIONS, OR OTHER DATA IS NOT TO BE REGARDED BY IMPLICATION OR OTHERWISE AS IN ANY MANNER LICENSING THE HOLDER OR ANY OTHER PERSON OR CORPORATION, OR CONVEYING ANY RIGHTS OR PERMISSION TO MANUFACTURE, USE OR SELL ANY PATENTED INVENTION THAT MAY IN ANY WAY BE RELATED THERETO.

Reproduced by
DOCUMENT SERVICE CENTER
KNOTT BUILDING, DAYTON, 2, OHIO

UNCLASSIFIED