

UNCLASSIFIED

AD NUMBER

AD041982

CLASSIFICATION CHANGES

TO: UNCLASSIFIED

FROM: CONFIDENTIAL

LIMITATION CHANGES

TO:
Approved for public release; distribution is unlimited.

FROM:
Distribution authorized to U.S. Gov't. agencies and their contractors;
Administrative/Operational Use; JUL 1954. Other requests shall be referred to Bureau of Ships, Washington, DC.

AUTHORITY

CFSTI per NAVY 1 Apr 1968 ; CFSTI per NAVY 1 Apr 1968

THIS PAGE IS UNCLASSIFIED

Armed Services Technical Information Agency

Because of our limited supply, you are requested to return this copy WHEN IT HAS SERVED YOUR PURPOSE so that it may be made available to other requesters. Your cooperation will be appreciated.

AD

41982

NOTICE: WHEN GOVERNMENT OR OTHER DRAWINGS, SPECIFICATIONS OR OTHER DATA ARE USED FOR ANY PURPOSE OTHER THAN IN CONNECTION WITH A DEFINITELY RELATED GOVERNMENT PROCUREMENT OPERATION, THE U. S. GOVERNMENT THEREBY INCURS NO RESPONSIBILITY, NOR ANY OBLIGATION WHATSOEVER; AND THE FACT THAT THE GOVERNMENT MAY HAVE FORMULATED, FURNISHED, OR IN ANY WAY SUPPLIED THE SAID DRAWINGS, SPECIFICATIONS, OR OTHER DATA IS NOT TO BE REGARDED BY IMPLICATION OR OTHERWISE AS IN ANY MANNER LICENSING THE HOLDER OR ANY OTHER PERSON OR CORPORATION, OR CONVEYING ANY RIGHTS OR PERMISSION TO MANUFACTURE, USE OR SELL ANY PATENTED INVENTION THAT MAY IN ANY WAY BE RELATED THERETO.

Reproduced by
DOCUMENT SERVICE CENTER
KNOTT BUILDING, DAYTON, 2, OHIO

CONFIDENTIAL

**NOTICE: THIS DOCUMENT CONTAINS INFORMATION AFFECTING THE
NATIONAL DEFENSE OF THE UNITED STATES WITHIN THE MEANING
OF THE ESPIONAGE LAWS, TITLE 18, U.S.C., SECTIONS 793 and 794.
THE TRANSMISSION OR THE REVELATION OF ITS CONTENTS IN
ANY MANNER TO AN UNAUTHORIZED PERSON IS PROHIBITED BY LAW.**

AD No. 661982

ASTIA FILE COPY

CONFIDENTIAL

National Communications Laboratories

A DIVISION OF INTERNATIONAL TELEPHONE AND TELEGRAPH CORPORATION

300 WASHINGTON AVENUE

NEW YORK, N. Y.

CONFIDENTIAL

**NOTICE: THIS DOCUMENT CONTAINS INFORMATION AFFECTING THE
NATIONAL DEFENSE OF THE UNITED STATES WITHIN THE MEANING
OF THE ESPIONAGE LAWS, TITLE 18, U.S.C., SECTIONS 793 and 794.
THE TRANSMISSION OR THE REVELATION OF ITS CONTENTS IN
ANY MANNER TO AN UNAUTHORIZED PERSON IS PROHIBITED BY LAW.**

CONFIDENTIAL

FINAL ENGINEERING REPORT

DEVELOPMENT OF
RATE-DATA STUDIES ON
RADIO SETS AN/URN-6 AND AN/ARN-26

PART I

SECTION A - PURPOSE

1. Contract by Bureau of Ships

1. This contract was initiated by the Bureau of Ships to determine rate and accuracy required of the tactical navigation system (AN/URN-3 and AN/ARN-21) and data transmission link (AN/URN-6 and AN/ARN-26) for automatically positioning aircraft from the ground.

2. It is the purpose of this study to relate navigation, data transmission, and the aircraft in one equation for automatic flight of varying accuracies and rates of navigation and data transmission information. The study has been based on automatic flight because of the difficulty of simulating a human in the loop.

3. To date, radar, flight plans, and voice radio reports have been the chief source of information for the control of carrier aircraft in tactical operations. The TACAN system and data transmission devices now under development permit all carrier aircraft to report their position in three coordinates, as well as report their direction of travel and speed. The same transmission system provides for ship-to-air order messages. The accuracy and rate at which the position and direction of travel are relayed to the ground, and orders sent back to the aircraft, determine the value of this data for automatic flight control. Speed maneuverability and response time of the aircraft to automatic control are other factors closely associated with this problem. This study therefore, considers the effects of rate and accuracy of the Automatic Data Transmission System on the

CONFIDENTIAL

CONFIDENTIAL

control of aircraft.

2. Scope of Study

4. Two aircrafts were to be studied under the provisions of this contract, the Grumman S2F-1 equipped with an Eclipse Pioneer P-1 autopilot, and the Douglas FSD-2 equipped with a General Electric G-3 autopilot. The Grumman S2F-1 is a low-speed, patrol-type aircraft while the FSD-2 is a two-place, high-performance, jet aircraft. Actually, only the S2F-1 aircraft was studied in detail for the following reasons:

5. (a) - It was the only aircraft on which sufficient, detailed information was received in time to make the investigations.

6. (b) - There was reason to believe that a scale factor could be derived that would extrapolate responses for any aircraft from the characteristic responses of the S2F-1.

7. Only the lateral mode of the aircraft behavior has been subjected to full simulator experiments. It was felt that "noise" effects are the most difficult problem in tight control of aircraft via a navigation and data transmission system. This noise is by far most significant in control of the aircraft-to-carrier bearing. Hence, the mode most closely coupled to bearing orders and reports was given the closest scrutiny.

8. The contract provides that simulated flight paths will be obtained using the same response time and characteristics for automatic control of aircraft but substituting in mathematical equations one at a time for the following tasks:

9. (a) - Terms for greater or lesser accuracy in azimuth, range, altitude, and heading.

10. (b) - Terms for greater or lesser rates of determination for azimuth, range, altitude, and heading.

CONFIDENTIAL

CONFIDENTIAL

11. (c) - Terms for greater or lesser accuracy in (air-to-ground) position and heading reporting.

12. (d) - Terms for greater or lesser rate of (air-to-ground) position and heading reporting.

13. (e) - Terms for greater or lesser accuracy in transmission of automatic control information from ground to air.

14. (f) - And terms for greater or lesser rate of transmission of automatic control information from ground to air.

15. Group treatment of some of these tasks turned out to be the most substantial method of attack. For instance, task (a) and (c) present a nearly inseparable error in considering the determination of accuracy in azimuth, range, altitude, and heading and the reporting of these accuracies to the ground. In addition, the error outlined in task (e) is relatively negligible in comparison to the other two accuracy errors. It was assumed, therefore, that a valid system analysis could be obtained by considering tasks (a), (c), and (e) as a lumped error and treating them accordingly.

16. Similarly, the rates of determination and transmission of information as outlined in tasks (b) and (d) fall into a single category.

17. Tasks (d) and (f) are considered one problem by virtue of the philosophy of the ARN/26-URN-6 system. In this system, a message sent from the ground to air initiates a return message instantaneously. These messages (ground to air and air to ground) are transmitted at discrete intervals as determined by the system transmission rate. For the purposes of this study the interval between the ground-to-air and the air-to-ground messages is negligible, and only the transmission rate need be considered. Therefore, these three tasks (b) (d) and (f) may be grouped under one consideration of data rate of transmission.

CONFIDENTIAL

CONFIDENTIAL

18. There is one further investigation not covered by the detailed requirements of the contract that assumes major importance in the consideration of a realistic system. There are seemingly innumerable external disturbances that affect the flight path and performance of the aircraft outside the realm of the measurable quantities of azimuth error, heading errors and the like. These disturbances act as forces on the airframe that tend to wrest the aircraft from its attitude of equilibrium. These disturbances may be in many different forms, the most common of which are wind disturbances. No aircraft is free from the effect of variable winds that act on it at any time and in any direction. It is therefore considered essential that an investigation of these additional disturbing forces be undertaken.

19. The purpose of this study, therefore, can be restated in light of the above: to investigate the effects on an automatic transmission system for the control of aircraft of (1) errors in navigation information, (2) transmission rates and, (3) external disturbing forces.

3. Method of Approach

20. The first objective was to duplicate a closed-loop system that incorporated all the components of a realistic system of automatic aircraft control. When each component was developed to the state where it accurately represented the part of the system for which it was designed, the study portion of the contract was undertaken. The purpose, mentioned previously, was to investigate effects of rate and accuracy of data transmission for the automatic control of aircraft.

SECTION B - GENERAL FACTUAL DATA

1. Identification of Technicians

21. Man-hours of work performed by engineers during the interim period, December, 1953, and January, February and March, 1954, are as follows:

CONFIDENTIAL

CONFIDENTIAL

B. Alexander	22 hours
M. Damon	361 hours
R. Jacobs	46 hours

2. Patents

22. Nothing to report.

3. References

23. Federal Telecommunication Laboratories, a division of International Telephone and Telegraph Corp., Proposal No. 1180, W.O.800 - 36095 and Interim Engineering Report Nos. 1 to 4 of this contract.

SECTION C - DETAIL FACTUAL DATA

1. Development of Components for the Study

a. Introduction

24. In devising a system for the analytic study of flight paths, it became necessary to develop several components that were necessary for a realistic duplication of an automatic flight control system. This system was by nature a closed-loop system and made up of the following components.

25. (1) - A unit which would represent the responses of an aircraft in accomplishing various flight paths.

26. (2) - An auto-pilot configuration by means of which the aircraft was automatically controlled by the ground controller.

27. (3) - A transmission system simulator that duplicated the navigation and data transmission systems.

28. (4) - A configuration of a flight-path computer which computed instantaneous flight-path orders based on information received from the aircraft or the ground.

CONFIDENTIAL

CONFIDENTIAL

29. (5) - A unit which would initiate a stimulus that represented external disturbances on the aircraft (wind, etc.). A blocked diagram of the components for the rate data study is shown in Figure 1.

b. Application of High-Speed Analog Computer

30. For performing such an analysis, a high-speed computer is particularly useful. For this study, Philbrick GAP/R High Speed All Electric Analog Computer components were used. A short discussion of component philosophy, quantitative data, and accuracy of the computer is offered to acquaint the reader of this report with the capabilities of the computer.

(1) Component Philosophy

31. The Philbrick Analog Computer is made up of a group of components capable of a set of operations that combine to make up the desired range of computing structures. The most important of these operations are: addition, multiplication by adjustable constant, and integration in respect to time. Most linear systems may be represented by the connection of components with these three operations with a great deal of authenticity. By adding simple nonlinear elements, such as those having limiting or suppressing properties, certain violent nonlinear systems are incorporated.

32. In its physical form, each component is unidirectional; information flows only from input to output. This does not prevent the study of bidirectional actions, since the two paths may be individually formed. The output signal capacity of each component makes negligible the load imposed by the input of another, so that it may "instruct" any number of others without correction.

33. Electronically, all computing signals are instantaneous d-c voltages with zero neutrals. Initial conditions are established by an external voltage wave - usually a step as has been used in this case - applied as a stimulus, and the responding solutions displayed on the oscilloscope through the

CONFIDENTIAL

appropriate variable voltages.

(2) Quantitative Data and Accuracy

34. The nominal voltage range for all variables is 100 volts, minus 50 to plus 50 volts. Feedback is so heavily applied that electronic variations affect sensitivity very little. Precision circuit elements of highest quality, and specified within tight tolerances, determine component characteristics.

Normal calibrations, fixed or central, are maintained to such accuracy. Thermal drifts within the computing time are negligible. Such accuracies as fidelity to dynamic form (as in integration), resolution, and precision (reproducibility of parameters) are of a high order. In cases under optimum conditions, these are found to be of the order of one per cent or less.

(3) Advantages of GAP/R in This Study

35. The application of a high-speed computer to this project can be easily seen. (By high speed, we mean speeds at which solutions may be presented repetitively on oscilloscope screens at speeds high enough so that flicker does not present a distraction problem to the operator.)

36. One of the more prominent advantages in this application is the use of the compressed time scale inherent in the machine. It has an effective time scale ratio of 2500:1.

37. High-speed computation allows immediate display of entire solutions on an oscilloscope screen. Large areas of useless results may be swept through and discarded in several seconds with the turn of the dial.

38. The instantaneous display on a CRO facilitates recording results by means of a CRO camera. In this connection, a DuMont 304-H CRO was used. It was particularly adaptable because of its high-gain and high-persistivity screen features. A Fairchild Polaroid Oscilloscope Camera F-284 was used to record oscillograms of results.

CONFIDENTIAL

c. Aircraft Simulation

39. Some types of dynamic systems have only one characteristic mode of motion, while others have more complicated systems of two or more at the same time. The airplane, being a somewhat complicated dynamic system, will move in several different modes at the same time. It is essential, therefore, for the aerodynamicist to understand the nature of these modes and to study their importance in relation to the handling qualities of the airplane from the pilot's point of view.

40. In order to determine the characteristic modes of motion for the airplane, it is necessary to set up and solve the airplane's equations of motion. The equations of motion are developed by application of Newton's laws for each of the airplane's degrees of freedom in turn, and the characteristics of the airplane's modes of motion are obtained by solution of the resulting simultaneous differential equations.

41. The airplane, considered as a rigid body in space, is a dynamic system in six degrees of freedom. Its total motion in space may be defined by six components of motion along and about the airplane axis system. Refer to Figure No. 2(A) of this report for a pictorial sketch of axis system.

42. The airplane axis system is a right-hand system of Cartesian coordinates with the X and Z axes in the airplane plane of symmetry and the Y axis perpendicular to the plane of symmetry out of the right wing. The origin of the airplane axis system is taken at the airplane's center of gravity, and the six velocity components are the linear velocities u , v , and w along these axes and the angular velocities p , q , and r about these axes. The airplane axes move with the airplane.

43. The mathematical treatment of airplane dynamics is based on methods introduced many years ago by men such as Bryant, Lanchester and Glauert. (Reference: see W. F. Durand's, "Aerodynamic Theory.") The basic theory through which the dynamic characteristics of the airplane are studied is based on the assumption

CONFIDENTIAL

that the disturbed motion of the airplane is one of small variations about some steady-state flight condition. There is also the assumption that the changes in the external forces and moments acting on the airplane, because of a small departure from the steady-state motion, depend entirely on the displacement and disturbance velocities along and about the airplane axis and do not depend on the accelerations involved. It has been proven that the results obtained correspond with sufficient accuracy to the actual results obtained through flight testing the aircraft.

(1) Evolution of the Equations of Motion

44. The equations of motion for an aircraft with controls locked may be written in accordance with the Newtonian laws of motion. These quantities are all measured in respect to axes fixed in space. Applying the Newtonian laws, the six equations become:

$$\begin{array}{ll} \Sigma F_x = ma_x & \Sigma L = \frac{dH_x}{dt} \\ \Sigma F_y = ma_y & \Sigma M = \frac{dH_y}{dt} \\ \Sigma F_z = ma_z & \Sigma N = \frac{dH_z}{dt} \end{array} \quad (1)$$

where F_x , F_y , and F_z are the summation of external forces and H_x , H_y , and H_z the angular momentum along and about the fixed axes X, Y, Z.*

45. The accelerations and rates of change of angular momentum must all be expressed along axes fixed in space. However, the axes chosen to represent the airplane are moving axes. Therefore, the acceleration and rates of change of momentum about the airplane axis must be referred back to the axes fixed in space.

* For complete definition of all terms in this section, refer to glossary.

CONFIDENTIAL

46. In order to determine the momentum of a body about the X, Y, and Z axes, refer to Figure No. 2(B). Consider a body having an angular velocity ω with components ω_x , ω_y , and ω_z about OX, OY, and OZ. The volume variation of angular momentum can be expressed by:

$$\begin{aligned}dh_x &= \omega_x(y^2 + z^2)dm - \omega_y(xy)dm - \omega_z(zx)dm \\dh_y &= \omega_y(z^2 + x^2)dm - \omega_z(yz)dm - \omega_x(xy)dm \\dh_z &= \omega_z(x^2 + y^2)dm - \omega_x(zx)dm - \omega_y(yz)dm\end{aligned}\quad (2)$$

where dh_x , dh_y , and dh_z are the OX, OY, OZ components of the rates of volume angular momentum.

47. For the whole body, the components of angular momentum about the three axes are the volume integrals of the above equations:

$$\begin{aligned}h_x &= \omega_x \int (y^2 + z^2)dm - \omega_y \int xydm - \omega_z \int zx dm \\h_y &= \omega_y \int (z^2 + x^2)dm - \omega_z \int yz dm - \omega_x \int xy dm \\h_z &= \omega_z \int (x^2 + y^2)dm - \omega_x \int zx dm - \omega_y \int yz dm\end{aligned}\quad (3)$$

The integral $\int (y^2 + z^2)dm$ is the moment of inertia about the X axis and is indicated as I_x . The integral $\int xydm$ is the product of inertia and is indicated as J_{xy} . Similar indications may be given to the other moments of inertia and products of inertia. Rewriting Equations (3) in these terms they become:

$$\begin{aligned}h_x &= \omega_x I_x - \omega_y J_{xy} - \omega_z J_{xz} \\h_y &= \omega_y I_y - \omega_z J_{yz} - \omega_x J_{xy} \\h_z &= \omega_z I_z - \omega_x J_{xz} - \omega_y J_{yz}\end{aligned}\quad (4)$$

CONFIDENTIAL

If axes are chosen as principal axes, the products of inertia vanish by definition. If the body contains a plane of symmetry, then the axis perpendicular to this plane will be a principal axis, thereby eliminating two products of inertia. The airplane is a body with just such a plane of symmetry taken to coincide with X-Z plane. The Y axis which is perpendicular to this plane will be the principal axis and the products of inertia, J_{xy} and J_{yz} , will vanish. In NACA terminology, ω_x , ω_y , and ω_z are called p , q , and r , respectively. Making these substitutions, Equations (4) become:

$$\begin{aligned}h_x &= pI_x - rJ_{xz} \\h_y &= qI_y \\h_z &= rI_z - pJ_{xz}\end{aligned}\tag{5}$$

Equations given in (1) relate to axes fixed in space. If the motion of the airplane is given relative to axes fixed in space, the problem becomes unwieldy, as the moments and products of inertia vary from instant to instant. To overcome this difficulty, use is made of moving Eulerian axes which coincide in some particular manner from instant to instant with a definite set of axes fixed in the airplane.

48. Referring to Figure No. 3(A), the general case with airplane axes rotating with angular velocities p , q , and r , the accelerations relative to fixed space are:

$$\begin{aligned}a_x &= \frac{du}{dt} - vr + wq \\a_y &= \frac{dv}{dt} - wp + ur \\a_z &= \frac{dw}{dt} - uq + vp\end{aligned}\tag{6}$$

CONFIDENTIAL

The rate of change of angular momentum relative to fixed space can be developed in a similar manner. Refer to Figure No. 3(B).

$$\begin{aligned}\frac{dH_x}{dt} &= \frac{dh_x}{dt} - h_y r + h_z q \\ \frac{dH_y}{dt} &= \frac{dh_y}{dt} - h_z p + h_x r \\ \frac{dH_z}{dt} &= \frac{dh_z}{dt} - h_x q + h_y p\end{aligned}\tag{7}$$

In these expressions $ax, ay, az, \frac{dH_x}{dt}, \frac{dH_y}{dt}, \frac{dH_z}{dt}$ are all measured relative to fixed axes and $u, v, w, h_x, h_y,$ and h_z are measured relative to the moving axis.

49. Substituting these quantities for the moving axes into Equations (1), the six equations of motion become:

$$\begin{aligned}\Sigma F_x &= m(\ddot{u} - vr + wq) \\ \Sigma F_y &= m(\ddot{v} - wp + ur) \\ \Sigma F_z &= m(\ddot{w} - uq + vp) \\ \Sigma L &= (\dot{h}_x - h_y r + h_z q) \\ \Sigma M &= (\dot{h}_y - h_z p + h_x r) \\ \Sigma N &= (\dot{h}_z - h_x q + h_y p)\end{aligned}\tag{8}$$

Making use of Equations (5) the equations of motion of the airplane relative to the moving or Eulerian axis become:

$$\begin{aligned}\Sigma F_x &= m(\ddot{u} - vr + wq) \\ \Sigma F_y &= m(\ddot{v} - wp + ur) \\ \Sigma F_z &= m(\ddot{w} - uq + vp)\end{aligned}\tag{9}$$

(CON'T)

CONFIDENTIAL

$$\begin{aligned}\Sigma L &= \dot{p} I_x - \dot{r} J_{xz} + (I_z - I_y) q r - p q J_{xz} \\ \Sigma M &= \dot{q} I_y + r p (I_x - I_z) + (p^2 - r^2) J_{xz} \\ \Sigma N &= \dot{r} I_z - \dot{p} J_{xz} + (I_y - I_x) p q + J_{xz} q r\end{aligned}$$

50. As mentioned before in the study of disturbed motions, only very small displacements or disturbances from some equilibrium flight condition are considered. Under this assumption, the disturbance velocities p , q , r are small. Therefore, it is allowable to disregard their products. Making this assumption Equations (9) become:

$$\begin{aligned}\Sigma F_x &= m(\dot{u} + \omega q) \\ \Sigma F_y &= m(\dot{v} + ur - \omega p) \\ \Sigma F_z &= m(\dot{w} - uq) \\ \Sigma L &= \dot{p} I_x - \dot{r} J_{xz} \\ \Sigma M &= \dot{q} I_y \\ \Sigma N &= \dot{r} I_z - \dot{p} J_{xz}\end{aligned} \tag{10}$$

The moving airplane axis system can be fixed with reference to the airplane in two different ways. One of these is to consider the axes fixed to the airplane under all conditions. These axes are termed body axes, with the X axis along the thrust line or fuselage center line. Another possibility is to consider the X axis always pointing in the direction of the relative wind. These axes are called the wind axes.

51. The wind axes are usually convenient as the component of airplane motion along the X axis will be the airplane's forward velocity $u = V$. Lift and drag forces will be along these axes and the components along the Z axis will be zero ($\omega = 0$).

CONFIDENTIAL

52. If wind axes are chosen as the airplane axes, and the assumption is made that changes of moments of inertia are negligible for small disturbances, the equations of motion in respect to the wind become:

$$\begin{aligned}\Sigma F_x &= m \dot{V} \\ \Sigma F_y &= m(\dot{v} + Vr) \\ \Sigma F_z &= -mV\dot{\gamma} \\ \Sigma L &= \dot{p} I_x - \dot{r} J_{xz} \\ \Sigma M &= \dot{q} I_y \\ \Sigma N &= \dot{r} I_z - \dot{p} J_{xz}\end{aligned}\tag{11}$$

53. Because of airplane's plane of symmetry, small symmetric disturbances will not introduce changes in the external forces and moments along or about the axes outside the plane of symmetry. Conversely, small disturbances in roll, yaw and sideslip will not introduce changes in the symmetric forces and moments. The symmetric degrees of freedom, therefore, do not couple with the asymmetric degrees of freedom, and it is possible to break the problem of the airplane dynamics down into two separate ones. They are called the longitudinal mode and the lateral mode. Only the lateral mode will be considered for the purposes of this investigation.

(2) Dynamic Equations for the Lateral Mode

54. There are five degrees of freedom for the lateral case. These five lateral degrees of freedom are as follows:

- (a) Velocity along the Y axis.
- (b) Rotation about the X axis.
- (c) Rotation about the Z axis.
- (d) Rotation of rudder about its hinge.

CONFIDENTIAL

(e) Rotation of aileron about its hinge.

55. In the study of this mode, it appears that the rudder and aileron hinge moments do not constitute an appreciable effect on the response of the aircraft. Accepting the validity of this assumption, the airplane need only be considered in its first three degrees of freedom as listed above for the purpose of the basic derivation of lateral mode equations. At a later date they will be neglected where feasible.

$$\begin{aligned}\Sigma F_y &= m(\dot{v} + Vr) \\ \Sigma L &= \dot{p}(I_x) - \dot{r}J_{xz} \\ \Sigma N &= \dot{r}I_z - \dot{p}J_{xz} \\ \Sigma H_a &= I_a \ddot{\delta}_a \\ \Sigma H_r &= I_r \ddot{\delta}_r\end{aligned}\tag{12}$$

where ΣF_y is the summation of all forces along the Y (wing) axis, ΣL and ΣN are summation of all rolling and yawing moments, respectively. For purposes of study, the X axis will be considered as essentially the principal one and J_{xz} vanishes. A pictorial view of the airplane axis system is given in Figure No. 4(A).

56. The acceleration along the Y axis, a_y , can be expressed in terms of the sideslip velocity v , and yawing velocity by letting $B = v/V$:

$$a_y = V(\dot{\beta} + \dot{\psi})$$

Applying the above two assumptions, Equations (12) become:

$$\begin{aligned}\Sigma F_y &= mV(\dot{\beta} + \dot{\psi}) \\ \Sigma L &= \dot{p}I_x \\ \Sigma N &= \dot{r}I_z\end{aligned}\tag{13}$$

(CONT)

CONFIDENTIAL

$$\begin{aligned}\Sigma H_a &= I_a \ddot{\delta}_a \\ \Sigma H_r &= I_r \ddot{\delta}_r\end{aligned}$$

57. In developing the lateral equations, the independent variables would be $\beta, \psi, \phi, \delta_a, \delta_r$. The total change in forces from some equilibrium is the sum of the partial derivatives of these forces in respect to each variable plus the rate of change and acceleration of the variables. In many cases, the partials do not exist but for a completely general case the equation may be written in this manner:

$$\begin{aligned}dF_y &= \frac{\partial F_y}{\partial \beta} d\beta + \frac{\partial F_y}{\partial \psi} d\psi + \frac{\partial F_y}{\partial \phi} d\phi + \dots \\ &+ \frac{\partial F_y}{\partial \dot{\beta}} d\dot{\beta} + \dots + \frac{\partial F_y}{\partial \ddot{\beta}} d\ddot{\beta} + \dots \text{ etc.}\end{aligned}\tag{14}$$

58. If the above equation of partials is examined completely, only two of these are important. The development of these two is shown in Figure No. 4(B). This diagram shows the forces along the airplane's Y axis.

59. It is known that any airplane at some angle of sideslip, β , will develop a crosswind or side force. Another component of side force is developed as a result of the airplane's bank angle, ϕ , which introduces the airplane's weight along the Y axis. None of the other variables introduces forces along the Y axis. Assuming small deflections for which derivatives are linear and the sine of the angle equal to the angle in radians, the equation becomes:

$$\Delta F_y = \frac{\partial F_y}{\partial \beta} \Delta \beta + \frac{\partial F_y}{\partial \phi} \Delta \phi\tag{15}$$

CONFIDENTIAL

at $t = 0$ $\beta, \phi, \psi = 0$

In coefficient form

$$F_y = C_y q S$$

substituting

$$C_y = \frac{\partial C_y}{\partial \beta} \beta + \frac{\partial C_y}{\partial \phi} \phi \quad (16)$$

The equation of motion along the Y axis for level flight (equilibrium) becomes:

$$\begin{aligned} C_{y\beta} \beta + C_L \phi &= \frac{mV}{qS_w} (\dot{\beta} + \dot{\psi}) \\ C_{y\beta} \beta &= \frac{\partial C_y}{\partial \beta} \end{aligned} \quad (17)$$

In Equation (17) the left-hand side of the equation is nondimensional. The derivatives $\dot{\beta}$ and $\dot{\psi}$ have dimensions of one over time (1/T), q in the constant on the right-hand side $\triangleq \rho V^2$ making the right-hand side $\frac{m}{\rho S_w V} (\dot{\beta} + \dot{\psi})$. The factor $\frac{m}{\rho S_w V}$ has dimensions of time. Assigning greek letter τ to represent factor $\frac{m}{\rho S_w V}$ and if time is counted in terms of time ratio $(\frac{t}{\tau})$, the right-hand side of the term may be expressed as $\frac{d\beta}{d(t/\tau)} + \frac{d\psi}{d(t/\tau)}$. By letting an operator $d = \frac{d}{d(t/\tau)}$ the right-hand side becomes $d(\beta + \psi)$. Equations (17) become:

$$\begin{aligned} C_{y\beta} \beta + C_L \phi &= 2d(\beta + \psi) && \text{and transposing} \\ (C_{y\beta} - 2d)\beta - 2d\psi + C_L \phi &= 0 \end{aligned} \quad (18)$$

This is the nondimensional equation of motion along the Y axis for level flight.

60. If the equation of motion in roll about the X axis is investigated, the rolling moment is a function of the following:

$$L = f(\beta, \psi, \phi, \delta_a, \dot{\delta}_a)$$

The remaining variables are negligible in respect to these. Writing the sum of the partial derivatives as was done before, the general equation is:

$$\Delta L = \frac{\partial L}{\partial \beta} \beta + \frac{\partial L}{\partial \psi} \psi + \frac{\partial L}{\partial \phi} \phi + \frac{\partial L}{\partial \delta_a} \delta_a + \frac{\partial L}{\partial \dot{\delta}_a} \dot{\delta}_a \quad (19)$$

CONFIDENTIAL

CONFIDENTIAL

In terms of rolling moment coefficient C_l ,

$$C_{l\beta}\beta + C_{l\dot{\psi}}\dot{\psi} + C_{l\dot{\phi}}\dot{\phi} + C_{l\delta a}\delta a = \frac{I_x}{qSb}\ddot{\phi} \quad (20)$$

To clarify our terminology and write the equation in a simple nondimensional form,

C_{lp} is the nondimensional rolling parameter.

$$C_{lp} \triangleq \frac{dC_l}{d(pb/2V)} \quad \text{where } pb/2V \text{ is the nondimensional roll-}$$

ing parameter. Demonstrating this convenient use with the damping derivative in roll

$$C_{l\dot{\phi}}\dot{\phi} = \frac{dC_l}{d(pb/2V)} \times \frac{b}{2V} \times \dot{\phi} \quad (21)$$

Making use of C_{lp} and the airplane density $\mu = m/\rho S b$ and applying the philosophy of the time parameter τ Equation (21) is:

$$C_{l\dot{\phi}}\dot{\phi} = \frac{C_{lp}}{2} \frac{\tau}{\mu} \dot{\phi} = \frac{C_{lp} d\phi}{2\mu} \quad (22)$$

Also the nondimensional yawing parameter $\tau b/2V$ can be applied where

$$C_{lr} = \frac{dC_l}{d(\tau b/2V)} \quad \text{giving} \quad C_{l\dot{\psi}}\dot{\psi} = \frac{C_{lr}}{2\mu} d\psi \quad (23)$$

and if $C_{l\dot{\delta a}}\dot{\delta a}$ be multiplied and divided by τ , then

$$C_{l\dot{\delta a}}\dot{\delta a} = C_{l d\delta a} d\delta a$$

Equation (20) becomes:

$$C_{l\beta}\beta + \frac{C_{lr}}{2\mu} d\psi + \frac{C_{lp}}{2\mu} d\phi + C_{l\delta a}\delta a + C_{l d\delta a} d\delta a = \frac{I_x}{qSb}\ddot{\phi} \quad (24)$$

The airplane's inertia I_x , is given by $m k_x^2$ where k_x is the radius of

CONFIDENTIAL

gyration about the X axis. Making use of μ , airplane density parameter and τ , the time parameter, the right-hand side of Equation (24) is treated as follows:

$$\frac{I_x}{qSb} \ddot{\phi} = \frac{2}{\mu} \left(\frac{k_x}{b} \right)^2 d^2 \phi \quad (25)$$

Finally the equation of motion in roll becomes:

$$\begin{aligned} \mu C_{l\beta} \beta + \frac{C_{lr}}{2} d\psi + \left[\frac{C_{lp}}{2} d - 2 \left(\frac{k_x}{b} \right)^2 d^2 \right] \phi \\ + \mu (C_{l\delta a} + C_{ld\delta a} d) \delta a = 0 \end{aligned} \quad (26)$$

61. A method of approach similar to that applied to the derivation of the last two equations may be applied to find the nondimensional equation of motion in yaw. This equation is:

$$\begin{aligned} \mu C_{nr} \beta + \left[\frac{C_{nr}}{2} - 2 \left(\frac{k_y}{b} \right)^2 d \right] d\psi + \frac{C_{np}}{2} d\phi \\ + \mu (C_{nr} + C_{nd} d) \delta r = 0 \end{aligned} \quad (27)$$

62. In summary, three equations have been derived that represent the lateral mode of an aircraft in level flight. These equations are:

$$(C_{y\beta} - 2d)\beta - 2d\psi + C_L\phi = 0 \quad (28-a)$$

$$\begin{aligned} \mu C_{l\beta} \beta + \frac{C_{lr}}{2} d\psi + \left[\frac{C_{lp}}{2} d - 2 \left(\frac{k_x}{b} \right)^2 d^2 \right] \phi \\ + \mu (C_{l\delta a} + C_{ld\delta a} d) \delta a = 0 \end{aligned} \quad (28-b)$$

$$\begin{aligned} \mu C_{nr} \beta + \left[\frac{C_{nr}}{2} - 2 \left(\frac{k_y}{b} \right)^2 d \right] d\psi + \frac{C_{np}}{2} d\phi \\ + \mu (C_{nr} + C_{nd} d) \delta r = 0 \end{aligned} \quad (28-c)$$

These are the three differential equations of flight. It is the intent of this study to solve these equations simultaneously by means of the analog computer, and

CONFIDENTIAL

to obtain responses that will be indicative of the flight-path responses of a simulated aircraft.

63. The use of the analog computer is justified to solve these equations as they are linear differential equations to which a computer of the type employed is particularly adaptable.

64. For solution, the equations must be set up using the computing structures of the computer. The complete lateral computer configuration for the lateral mode equations is shown in Figure No. 5.

(3) Reduction of the Lateral Mode

65. The configuration of the aircraft, as set up on the Philbrick Analog Computer, has just been demonstrated. While this is a complete configuration, it is rather unwieldy and uses many computing components. While this structure is an exact representation of the aircraft, a reduction in the configuration is desirable from several standpoints. A smaller structure is much easier to handle physically, and the components not used would be free for other computing applications that are necessary further along in the study.

66. This simplified configuration is feasible and valid if certain restrictions are enforced in making the reductions. First of all, there must be no appreciable change seen in the time-constant of the response. Secondly, there must be no appreciable change seen in the transients of the response. With these restrictions in mind, a reduction of the lateral mode configuration was made.

67. Several methods of simplifying are feasible in the reduction of the circuit. These are outlined below.

68. (a) The Philbrick Computer contains coefficient units which have values of amplification ranging from 0 to 100. For values greater than unity, these units are used in the aircraft analogue. However, when the values of amplification required for a setup are less than unity, the Philbrick Coeffi-

CONFIDENTIAL

cient units are replaced by potentiometers. This reduces the size and power requirements of the over-all circuit.

69. (b) Coupling units which introduce the output of any unit into the mixing unit of any other loop circuit may be omitted if the values of coupling are "negligible." Whether or not these values are "negligible" may be determined by turning the value of each coupling unit separately to zero and observing the change in the output of each of the loop circuits in Figure No. 5. In those cases where the coupling value could be reduced to zero without appreciably altering the outputs as viewed on an oscilloscope, the coupling units were omitted in order to simplify the circuits.

70. (c) When two amplifying units are in cascade, they may be replaced by an amplifier whose value is equal to the product of the two amplifiers which were in cascade.

71. (d) A single-degree-of-freedom feedback loop circuit comprising mixing unit, amplifying unit, integrating unit, and feedback-amplifying unit, may often be replaced by a mixer and amplifying unit whose gain is equal to the gain of the original loop circuit, if the time constant of the original loop circuit is very short compared to the delays in elements in tandem with the original loop.

72. The time constant of a feedback loop is equal to the reciprocal of the product of the forward amplifier and the feedback amplifier.

73. The validity of such a simplification must be verified by comparing the oscilloscope response of the original entire loop and the modified loop, and finding them negligibly different.

74. The above outlined reductions were made in the lateral mode configuration. The resulting modified loop is demonstrated in Figure No. 6.

CONFIDENTIAL

CONFIDENTIAL

d. Autopilot Simulation

75. In fighter type aircraft, the autopilot becomes an integral part of the airplane rather than an accessory item. The extreme maneuverability, the rapidly widening range of flight speed and altitude, and the general high-performance characteristics of fighter-type aircraft have imposed increasingly difficult control problems - the solution of which requires consideration of system designs and compatibility between the characteristics of the airplane and the automatic pilot.

76. Fighter-plane automatic pilot performance standards demand immediate and accurate response, rapid maneuvering, proper anticipation, and "tight" positive control of the airplane; i.e., quick sensing and quick reaction, the prerequisites of the fighter pilot himself. With these more stringent dynamic control requirements, the aerodynamics of the airplane and its performance limitations become the automatic pilot design criteria.

(1) Automatic Pilot Configuration for This Study

77. The autopilot used in this system is a heading-sensitive autopilot. This autopilot controls the aircraft in its lateral mode creating a change of heading, through bank, by means of an aileron deflection. The input to the autopilot includes bank angle, the heading, and the ordered input. These last two items combine to give a heading error signal. The response sensitivity is controlled by means of the ratio of the bank angle to the heading gains. This ratio regulates the "snappiness" of response as indicated by the unit change of bank angle per unit of heading error. In this particular case of this study, the sensitivity unit selected is two degrees (2°) of bank angle (ϕ) per degree (1°) of heading error.

78. The above arrangement is deemed suitable for satisfactory control of the aircraft. Any delays that might be inherent in an extremely exact

CONFIDENTIAL

duplication of an autopilot are not incorporated in this configuration, as the time-constant of these delays is considered to be negligible in respect to the aircraft response times. For all practical purposes, the aileron deflection is instantaneous in its response to a given order through the autopilot and the governing time-constant of response is the inherent delay in the responses of the aircraft itself.

e. Transmission Simulation

(1) Concepts

79. The simulation of an aircraft, which was performed using the Philbrick Computer, was for the purpose of computing the flight responses of an aircraft, considering only those delays due to the aircraft's flight characteristics. In the subject contract, the final results must be based upon the delays of the entire loop, which includes not only the aircraft but the communication channel from air to ground and from ground to air.

80. In order to compute the aircraft's flight path with all delays being taken into consideration, a device was developed for simulating delays in the circuit between the air and ground as well as the circuit in the reverse direction. This device is the "data-transmission simulator."

81. The actual data links under development are capable of handling transmissions at any frequency lower than a limiting value, and it is the purpose of the subject contract to determine how low a repetition frequency of this control information may be used before the transmitted intelligence becomes too sparse to properly control the aircraft's flight.

82. The simulation of the entire communications loop was performed by the data-transmission-simulator circuit, which stores amplitudes of a continuously varying correction signal, sampled at time intervals which can be varied by the experimenter. These intervals which separated the instants of amplitude

CONFIDENTIAL

CONFIDENTIAL

measurement are equivalent to data rates varying from ten per second to one each forty seconds in the physical data link. Since the Philbrick Computer with which the data-transmission-simulator circuit was used converts equivalent time by a factor of 2500, and a complete command signal employs one-half a cycle in the simulated system, the sampling (or quantizing) time intervals vary from 1/50 millisecond to 8 milliseconds.

83. At discrete intervals, the transmission simulator measures a correction signal which is a function of the difference between the simulated command signal and the instantaneous value of the aircraft parameter under control as received via the data link.

84. A graphic representation of the operating principal of the data-transmission simulator is demonstrated in Figure No. 7. This shows the detailed relationship between data received at discrete intervals from the aircraft and the ground ordered correction.

85. Consider part (a) as the composite error signal, or proper combination of the deviation of an aircraft from an ordered track and its departure from the proper heading. This error may have developed during an ordered track change.

86. The discrete intervals at which information is transmitted to the aircraft are indicated as divisions along a line (AB) which represents the equilibrium flight path desired. In accordance with the philosophy of the data link, every message from ground to air initiates a return message from air to ground. There is no delay in the return message and the total elapsed time for the two operations is so small in respect to the data rate that they can be considered to happen at the same instant. The response from the aircraft would contain position information of the aircraft.

CONFIDENTIAL

87. Since the position information report of the plane is available only when messages are sent, and no further correction signal can be sent for the discrete interval until the next message transmission, the correction must be computed from the last available data which was received (i.e., at the instant of the last message). This means there is a time delay between the time that position information is received and the time that a correction based on this information can be transmitted to the plane. If the transmission rate is rapid, then the ground is receiving position information and computing and sending correction signals at very short intervals, creating the effect of nearly continuous corrections to the aircraft. On the other hand if the transmission rate is slow, there will be a delay between the time that the position information is received and a correction signal computed, and the time that this correction signal is transmitted to the aircraft. By this time, the aircraft will undoubtedly be in some other position, but the ground must compute its correction on available information which had been stored from the previous (and perhaps prior) message receptions.

88. Part (b) of Figure No. 7 shows the position error signal being measured at discrete intervals. The repetition date of this interval is the message rate but for purpose of discussion, each interval will be indicated numerically: i.e., 0, 1, 2, 3, etc. Part (c) shows the correction signal that is sent to the aircraft. It is desirable from the standpoint of understanding, to follow the procedure for a few intervals.

89. At $t = 0$, the aircraft is given a command to follow a track. The aircraft starts to respond. At interval 1, the ground order is based on the position information received at the previous interval. No position error was recorded here so no correction signal is sent with this message. At interval 1, however, when the message is sent, a position error of the magnitude as shown at interval 1 is measured and sent back to the ground. Now at message 2 a correction

CONFIDENTIAL

signal can be sent, but this is of a magnitude based on error as measured at the previous transmission. (The correction signal is opposite in direction as the measured position error signal.) Similarly, the correction signal sent at message 3 is computed from position error received at 2 and stored until message 3 is sent. The correction signal sent at interval 4 is computed from position error received at 3 and stored until message 4 is sent.

90. From this, it is obvious that the ground order (the computer correction signal) lags the measured position error by one message interval.

91. It is also readily understandable what an effect the rate of transmission has on the position control of the aircraft. By increasing the rate at which the continuously recomputed data signals are transmitted between the ground and the aircraft, the response of the aircraft will show the effects of "tighter" control up to a point beyond which no further improvement may be accomplished, due to the fact that the aircraft's inherent responses are not to be improved despite faster data rates. At slower data rates, the aircraft will show increasing departure from desired flight path due to "looseness" of control to a point where the rate is too slow to give any correction effects whatsoever.

92. It is therefore the objective of the data-transmission simulator to perform operations that will duplicate the concepts of the transmission system as outlined in the preceding paragraphs.

(2) Data-Transmission-Simulator Circuit

93. There are two goals outlined in the previous section that must be attained to create a data-transmission simulator. They are, first, to have the ability to store certain discrete information in the system and to pass this on at certain discrete intervals; and second, to be able to control the repetition rate of these discrete intervals at will over the prescribed range of transmission rates of the data link. A circuit has been developed to accomplish these goals.

CONFIDENTIAL

CONFIDENTIAL

94. Figure No. 8 is a schematic diagram of the data transmission simulator. The principle of its operation lies on its ability to store certain discrete information on condensers and to pass this information on at discrete time intervals. To obtain this goal, there are two separate condensers which are charged to the amplitude of the continuously varying correction signal and discharged at specified intervals. (In this case this signal is $f \int_{(\beta-\eta+\psi)}^{(n-\psi)} + K_f u$) (This will be discussed in detail later in the report.) In Figure No. 8, these condensers are designated as C_1 and C_2 .

95. A typical cycle of operation may be described as follows. Assume for purposes of this consideration that old information is on C_2 and new information on C_1 . In the first step of the cycle, C_2 is gated to ground and the condenser is completely discharged, ready to store new information. In the second step of the cycle, a gate is actuated which allows the voltage on C_1 to control charging of C_2 . In the third step of the cycle, condenser C_1 is discharged to ground and prepared for the new signal. In the fourth and final step of the cycle, a gate is actuated and a new voltage is stored on C_1 .

96. The timing of each step in the cycle, as well as the frequency, is carefully controlled. This is accomplished by the use of a free-running multivibrator and a series of four one-shot multivibrators. The pulses obtained from the consecutive one-shot multivibrators are used to trigger the four operations in each cycle.

97. The free-running multivibrator establishes the frequency of the cycles. This unit is capable of furnishing a square wave with frequencies from 125 cps to 50 kc. It is accomplished in two ranges: the first, from 125 cps to 2.5 kc which will be called the "low range"; and the second, from 2.5 kc to 50 kc which will be called the "high range." These ranges are obtained by switching condensers. Within the ranges, the frequencies are regulated by a ganged one-

CONFIDENTIAL

megohm potentiometer. This changes a governing time constant, and consequently the frequency of operation.

98. The square wave generated by the free-running multivibrator is differentiated, inverted, and used to trigger a one-shot multivibrator. The one-shot multivibrator operates through one cycle furnishing a pulse. The positive pulse is used to activate a gate. This output is also differentiated and the same procedure follows for each of the three remaining one-shot multivibrators.

99. Each of the one shots in sequence furnishes a pulse which actuates one step in the operation of one cycle. It can be noted that the one-shots also have capacitor switching. A two-microsecond pulse is formed for use in the high range, and, by switching, a forty-microsecond pulse is formed which is used in the low range.

100. In this manner, a frequency of operation is established and during each cycle four steps are accomplished. This assures that the condensers C_1 and C_2 are not only charged and discharged in an accurate manner, but also that the frequency of these operations can be accurately governed. This allows the circuit to simulate operations from 125 cps to 50 kc in real time, which in the time scale of the Philbrick Computer will be operations from about 10 times a second to about one every 40 seconds.

101. The data-transmission simulator is packaged for optimum use by the experimenter. A front panel is provided, upon which all control instruments are mounted. The experimenter may control the range over which the unit is to be operated by a "high-" and "low-range" switch, control the frequency of the free-running multivibrator by a potentiometer control, and control the output by means of a potentiometer. The panel also incorporates convenient input and output jacks, plus several test points where important points in the circuit may be reviewed.

CONFIDENTIAL

102. By means of this circuit the operation of the data transmission system is reproduced in the form of a simulator for use in the study.

f. Ground-Controller Simulation

(1) Concepts

103. The objective of this contract is to determine the effect of discrete data transmission rate upon the flight response of an aircraft under closed-loop ground control. As has been previously discussed, the closed loop is made up of analogs of the aircraft, the autopilot, the discrete data link, and the ground controller. The "ground-controller simulator" is the only concept not yet covered. This section outlines in brief the theory of its operation.

104. The ground controller is that element of the closed-loop system that is assumed to be capable of governing the flight path of the aircraft. This is accomplished through orders given to the airplane in form of track changes and correction signals given to the aircraft based on error data. By use of the ground controller, the positioning of the aircraft can be controlled.

105. It is assumed for purposes of this study that the ground controller has available a high-speed flight-path computer, which computes flight-path correction signals based on aircraft position errors. For instance, reservation must be made to provide a place to insert an ordered track change, and also to compute new correction orders to be transmitted to the aircraft that will bring the aircraft finally to the desired track.

(2) Flight-Path Control

106. Ordered heading changes are transmitted to the aircraft system by means of an aileron deflection. If the concept that all turns are coordinated is accepted, which is in fact an extremely valid assumption for these applications, then the rate of change in heading is proportional to the bank angle. On these premises then, the magnitude of the bank angle governs the lateral mode maneuvering

CONFIDENTIAL

CONFIDENTIAL

of the aircraft. The magnitude of the bank angle is determined by two factors, (1), heading error, and (2), track error. It is necessary to evaluate these two magnitudes separately to get accurate flight-path response. Ordering a plane to a new flight path by heading error alone is not sufficient. It is obvious that under certain conditions (external disturbances, large flight path orders, etc.,) that in an aircraft being controlled by heading alone, the heading error would go to zero before the aircraft had actually attained the actual flight path as ordered. For this reason, another component of the bank-angle magnitude is the track error or deflection error from the ordered flight path. With this magnitude present, even if the heading error goes to zero, the deflection error remains and provides the signal necessary to bring the aircraft back to its ordered flight path. By use of the combination of these two errors, the aircraft can be effectively controlled.

(3) Heading-Error Derivation

107. The heading error is simply the difference between the heading of the aircraft (ψ) and the ordered heading of the flight path (γ). The aircraft heading is one of the responses of the aircraft and may be extracted directly. The heading ordered is injected by the ground controller and will be discussed later in the report. To write the heading error in equation form

$$P_e = (\gamma - \psi) \quad (29)$$

where γ = ordered heading and ψ = heading of the aircraft.

(4) Deflection-Error Derivation

108. The derivation of the deflection error is demonstrated graphically in Figure No. 9 entitled "Determination of Rate of Deflection." By considering the forces acting on an aircraft at any instant along its flight path, it is possible to determine by trigonometric analysis the value of the rate of

CONFIDENTIAL

deflection ($\dot{\delta}$). The rate of deflection in ft/sec is:

$$\dot{\delta} = v - u(\eta - \psi) \quad (30)$$

where v is the sideslip velocity and u is the forward velocity. Letting $v = \beta u$ where β is the angle of sideslip, obtained directly from aircraft simulation, and integrating the rate of deflection ($\dot{\delta}$) to find the deflection δ in feet, the equation becomes:

$$\delta = u \int (\beta - \eta + \psi) dt \quad (31)$$

109. The bank angle command is the sum of these two signals, the heading error and the deflection error, with their respective gain factors. In equation form:

$$C\phi = K_A [(\eta - \psi) + K_S u \int (\beta - \eta + \psi) dt]$$

where K_S = position deflection gain

K_A = autopilot gain.

110. Making use of the concepts outlined about the Ground-Control Simulator, exercises distinct control of the aircraft from the ground. This analog is added to the others to complete the closed-loop system for flight-path analysis.

2. Flight-Path Analysis

a. Theory of Flight Paths

111. The purpose of this study is to investigate the effects of transmission rates, azimuth errors and external disturbances on the aircraft response characteristics. To do this, a closed-loop system for flight-path analysis has been set up. Each of the components of the closed-loop system has been evaluated previously in this report. The incorporation of these analogs into a composite,

CONFIDENTIAL

closed-loop system is shown in Figure No. 10. Further discussions of flight-path analysis will be based on this schematic diagram.

112. For the purposes of flight-path analysis, a step input of discrete ordered track direction is used as a forcing function. There are several reasons why this type of forcing function was used: (1), sources are readily available that allow some degree of control to be exercised over the step, such as magnitude control and in application of a square wave, control of the frequency; (2), such a forcing function is completely descriptive; and (3), discrete track-direction step orders are most likely found in procedure maneuvering in actual practice. The magnitude of the input function is calibrated as a function of the magnitude of the ordered track change.

113. For the purposes of this study, a square wave of 10 cycles/sec is used as a step-function input. This function is one-half-cycle positive and one-half-cycle negative. One half of a cycle is studied at a time. Converted to machine time at the ratio of 2500 to 1, and applying τ , the nondimensionalizing time factor of the aircraft (3), this half cycle appears as six minutes in real time as displayed on the CRO. It is this time interval that is used as a base in the study of the responses.

114. The cyclical square wave is especially suited to application in this study. In effect, the aircraft is being given orders of equal magnitude alternately in each direction. This path gives the investigator ample opportunity to study the responses as the aircraft is given a discrete flight path to follow first to the right and then to the left.

115. Perhaps a more graphic demonstration of this principal can be obtained by referring to Figure No. 11. Here the ordered track and flight-path response are sketched for a typical command used in the flight-path evaluation. By investigating the response of the aircraft to such an ordered track, together

CONFIDENTIAL

with certain other conditions (such as wind disturbances, transmission rates, etc.,) analytical results can be obtained.

b. Transmission Rates

116. The study of transmission rates can be accomplished by use of the data-transmission simulator, with varying transmission rates. There are practical limits to the repetition rates that need be explored. The upper limit of the transmission rate is where an increase in repetition rate can not improve the quality of response of the aircraft. The lower limit is where the rate is slower than a practical data link would employ. Generally speaking, the transmission rates were kept within this region. More specifically, rates of $\sqrt{10}$ messages per second, to one message every ten seconds were used for a definite region in which to conduct quantitative measurements.

117. To demonstrate the effect of transmission rate, see Figure No. 12. This shows the effects of transmission rate only on the responses, as in this series no limits were imposed on the system and no external disturbances such as errors or wind were injected into the system. Oscilloscope pictures of bank angle, heading, and deflection responses are displayed. Note that no appreciable change in bank-angle response is apparent. In the heading and deflection responses, however, there are noticeable changes in amplitude and time constant at the lower data rates.

c. Limits on the System

118. In order to simulate the finite bounds of aircraft maneuverability from both a physical and practical viewpoint, certain limits are proposed for the system.

(1) Bank Angle Limit

119. One of these is a limit of bank angle, (indicated as B_2 on schematic diagram). It allows restricting of bank angle called for by error signal

CONFIDENTIAL

so that the plane never assumes an excessive roll attitude. Factors which, in certain circumstances, could indicate a tighter setting of this limit are pilot discomfort due to the effects of noise (see para. d., below) G loading, and landing altitude control. This limit is in effect creating a nonlinear restriction on the system.

120. For the effect of a limit in bank angle on the systems refer to Figure No. 13. In this case the bank angle was limited to a small value of ± 2 degrees. No errors or other disturbing factors were injected. The effects of this limit are prominent in all three of the displayed responses. The display of the limit on the bank-angle response may be observed. It also restricts the rate of turn so a rather well-defined slope of heading response is present. An even more pronounced effect is seen in the deflection response. Note that the response time is much more sluggish due to the limit in bank angle. (Compare Figure Nos. 12 and 13.)

121. Digressing momentarily from the main subject of the report, it is interesting to investigate the effects of the magnitude of bank angle on the rate of turn. Figure No. 14 of this report is a plot of rate of turn verses bank angle for coordinated turns. It is also interesting to observe these results for varying rates of forward velocity. As expressed in graphic form for a given bank angle as the forward velocity of the aircraft increases, the rate of turn in degrees per second becomes progressively slower. It can be seen that for a high-speed aircraft with a small allowable bank angle, the time of response would be prohibitively long for quantitative observation within the capabilities of the present system.

(2) Heading Limit

122. In Interim Engineering Report No. 4, reference was made to the need of having a limit in the heading called for by deviation. At that time,

CONFIDENTIAL

CONFIDENTIAL

considerations were made to insure that for large magnitudes of ordered track change, say 90 to 180 degrees, the aircraft would not return to this track at some impractical heading. If a large track change order were given to the aircraft, it is conceivable that it would fly at a rate of turn limited only by bank angle until there was no longer a heading error, but at this point a large track deviation might still exist. The deviation error would call for a large heading change and the aircraft might well fly back to the ordered track at some unreasonable angle. For such magnitude of orders, the limit in heading called for by deviation is warranted.

123. However, after further study of the criteria for assumptions made in the development of certain components for this study, large magnitude track orders are not feasible. For instance, the aircraft simulation validity depends on the assumption that only small disturbances from an equilibrium flight path are injected. Therefore, for analytical study, only small track orders will be given, on the order of 15 degrees or less. For this magnitude of order, no heading called for by deviation error limit is deemed necessary. No large deviation errors will be developed under these conditions.

d. Error Considerations

(1) Philosophy of Accuracies in Position Information

124. The limiting factor in the tightness of control of the aircraft is the accuracy of position information. If the position information were perfect, the limit would be aircraft maneuverability. However, with present navigation systems, position errors largely overshadow the other limits. In the case of R - θ navigation systems, the uncertainty in θ makes this factor assume particular importance at or near the extreme range of the system. A reasonable figure for the rms error in azimuth information is $\pm 1/2$ degrees. This amounts to about ± 1.7 miles at a two hundred mile range. It has been assumed that the distribution

CONFIDENTIAL

CONFIDENTIAL

of these errors will take the form of a random variation centered very close to the correct position. In addition, the frequency spectrum is considered to be flat (random in time as well as space). The high-frequency cutoff of the spectrum, due to the time constant of the navigation system, may be ignored.

(2) Noise as Used in This Study

125. In the present system, the manner in which these inaccuracies are introduced is by injecting a pure white or random noise source in the deviation loop. The noise injected must be truly random and certain assumptions must be made about it.

126. (a) First the error must be assumed to be random from transmission to transmission. If the noise is sampled at a discrete rate, then each sample must be as random and of the same rms value as any other sample. This also assumes that any other error than that duplicated by the purely random noise, even of the same rms value, creates a less violent perturbation on the aircraft. The manner in which noise creates the disturbance will be discussed later in this section, wherein the above assumption will be held valid.

127. (b) Secondly, in accord with previous criteria determination for this study, it is assumed that the aircraft is flying so that azimuth error will have the most effect. Therefore, the random noise will be used to indicate this error.

128. For purposes of this study, noise was obtained from the phone output of a Hallicrafter SX-28, with the r-f gain turned up. By allowing control of the magnitude of the noise, and injecting it into the deviation loop through a coefficient unit of the computer, it is possible to simulate the magnitude of deviation error due to noise (azimuth error) present at any range.

CONFIDENTIAL

(3) Error Objections and Reduction of Error Effect

129. In order to have the aircraft return to its ordered flight path quickly, the position gain K_S must be large. However, in using this high value of gain for fast response, the effect of the random noise signal is also large and causes the aircraft to maneuver violently. This is most noticeable in bank angle since the plane rolls violently first to one side then to the other. This, of course, is an undesirable situation and some scheme which would effectively limit the effect of the noise signal and still provide some deviation control is desired. There are several methods of attacking this problem. In a sense, these methods are integrating devices to obtain more feasible roll-rate characteristics.

130. The objective is to reduce the violent effect of errors to an acceptable tolerance. For purposes of this study, an acceptable "flutter" of bank angles is taken arbitrarily as ± 2 -degree maximum for ordinary service. One method of obtaining this goal is to reduce the deviation gain until the effect of the random error is within the accepted criteria (± 2 -degree θ). The effect of this small position gain (K_S) with the random error injected on the bank angle (θ), the heading (ψ) and the deflection (δ) is demonstrated graphically in Figure No. 15. The random error of a magnitude which represents this position error at a range of 50 miles was injected for these responses.

131. Compare these results shown in Figure No. 15 with those shown in Figure No. 16. The later gives response of bank angle, heading, and deflection with a deviation gain equal in magnitude to the previous configurations; but with no random error injected.

132. Another method of integrating out the effect of the error signal is to limit the bank angle called for to the acceptable criteria of ± 2 -degree θ . This method has the advantage that the deviation gain does not have to

CONFIDENTIAL

be reduced, and it filters through the limited bank angle by calling for a bank angle more often in one direction than in the other. The deviation gain in this instance is on the order of 10 times its magnitude in the reduced K_S case.

133. A display of the effects of an error signal so limited on the bank angle θ , heading (ψ), and deflection (δ) responses is shown in Figure No. 17. The random error of a magnitude which represents this error at a range of 50 miles was injected for these responses.

134. Comparison can be made with a similar setup using a limited bank angle of ± 2 degrees, but with no error signal injected, by referring to Figure No. 13.

135. As was indicated, both the previous error signals used for the demonstrations of these two methods were of a magnitude that represented errors at a 50-mile range. For further demonstration of the effects of this random error, refer to Figure Nos. 18 and 19. For these runs, a random error signal equivalent to a range of 200 miles was used. Figure No. 18 is a display of bank angle θ , heading (ψ), and deflection (δ) for responses with the reduced position gain (K_S) and the error at 200 miles injected. Figure No. 19 is a display of these same responses with the bank angle limited (± 2 degrees) and the error at 200 miles injected.

e. Consideration of External Disturbances

136. As described earlier in the report, there are other factors which seriously effect the positioning of the aircraft. Heretofore, these factors have been called external disturbances. Probably the most prevalent of these external disturbances is wind and for purposes of further discussion, will be referred to as such. Wind must be investigated as it is a continuous problem in flight.

137. It is possible to duplicate the effect of a crosswind on flight paths by injecting a step, properly calibrated into the deviation loop of this

CONFIDENTIAL

system. (Refer to Figure No. 10 for the point of injection.) This step of wind is injected simultaneously with the ordered track command so as to take effect at the instant the order is given.

(1) Effect of Crosswind on Aircraft Responses

138. To evaluate the effect of crosswind on the flight paths, a signal whose magnitude represents a 10-knot crosswind was injected into the system. It is interesting to observe the effects of this disturbance on the various aircraft responses.

139. Figure No. 20 displays the effects of a 10-knot crosswind on the responses in bank angle (χ), heading (ψ), and deflection (δ) with the bank angle limited to 12 degrees. Note that the predominant effect is in the deflection response. A small constant deviation exists when it reaches the steady-state portion of the response.

140. Figure No. 21 displays the effect of a 10-knot crosswind on responses with small position control (K_{δ}). Here the effect on the deflection response is more noticeable. The deflection is, for the most part, divergent and when it finally reaches an equilibrium flight path, a large deflection error exists.

SECTION D - CONCLUSIONS

1. Procedure Findings

141. If the system as set up for this study could be considered ideally, i.e., with no transmission inaccuracies or external disturbances considered, accurate measurements of rate data for optimum performance could be obtained. Under these conditions, the "snappiness" or "sluggishness" of an aircraft could be determined as a function of rate data for most any maneuver.

CONFIDENTIAL

142. Practically, however, with azimuth errors and other external disturbances being brought into account, the sharp response with short time constants can no longer be hoped for, as the means of restricting the effect of these disturbances also makes the response more sluggish.

143. There are two means of limiting the effect of azimuth errors (noise). Each in effect is a device that smoothes out the violent maneuvers called for by the azimuth errors. One of these methods is to reduce the deviation gain to a point where the random error signal does not have more than an allowable effect (± 2 -degrees ϕ). The second method is to restrict the bank angle of the aircraft so that no response called for can be greater than allowed by the ± 2 degrees of bank angle. In this method, the deflection signal filters through the limited bank angle, calling for a bank angle more often in the direction of the desired flight path than in the other. It is feasible to evaluate these two methods.

144. In evaluating these two systems in the presence of azimuth errors only, refer to Figure Nos. 15 and 17. The following deductions are made from these displays.

145. (a) The case of the bank angle being limited (± 2 degrees), there is a greater path deflection than in the case of small deviation gain (K_g).

146. (b) The case of limited bank angle, however, shows a better damping characteristic to the ordered flight path than does the case of small deviation gain.

147. If this system were evaluated on this basis alone, it would be difficult to decide which of the methods was more effective. A more academic evaluation could be made if only this type of disturbance were present. In a practical system, as has been represented in this study, however, other external disturbances become evident which tend to make the evaluation of the two systems less difficult and on more finite grounds than in the previous case.

CONFIDENTIAL

CONFIDENTIAL

148. In addition to inaccuracies in azimuth information, the effect of wind must be considered. To once again evaluate the two methods of limiting the effect of the disturbances, refer to Figure Nos. 20 and 21. The following results are obtained from this comparison.

149. (a) In the case of limited bank angle ± 2 degrees, a 10-knot crosswind creates a small steady-state deviation in studying the deflection (δ) response of the aircraft.

150. (b) In the case of small deviation gain, the deflection error has a large steady-state value. In this case, a 10-knot crosswind is considered, the steady-state error for small position gain being on the order of ten times the steady error created with the bank angle limited.

151. On the basis of these evaluations it is obvious that in the face of both azimuth inaccuracies (random noise) and winds, better position control is available by use of the limited bank-angle method of reducing effects of the random error signals.

PART II - RECOMMENDATIONS

1. Findings for the Study

a. Transmission Rates

152. In an ideal data link with no navigation system errors or unknown winds, transmission rates could be accurately determined for optimum responses. In the presence of these disturbances, however, the positioning does not depend so crucially on the rate data, the effect of some of the random errors overshadowing their value.

153. In view of the effects of these disturbances, a statement may be made regarding the upper boundary of the transmission rates. In the case where only the azimuth inaccuracies (random noise) is considered, a message rate of one

CONFIDENTIAL

message per three seconds is about as effective as continuous information. (Infinite rate data.) That is, rate data with higher repetition rate than one message per three seconds, produce no appreciable improvement in aircraft positioning control.

154. Where external disturbances such as wind are considered, message rates of one message per ten seconds are about as effective as continuous information.

b. Positioning in the Presence of Errors and External Disturbances

155. Taking all the previous evaluations of the system into account, it is possible to arrive at a suggested means of positioning an aircraft. This means of positioning is derived in the presence of navigation errors and external disturbances, such as wind.

156. For large changes in position, i.e., large ordered tracks, the aircraft is controlled by heading alone. This eliminates the presence of errors that are injected through the deviation loop. The plane is given flight path commands that are a function of the heading error signal. ($\eta - \psi$ where η = ordered track, and ψ = aircraft's heading.) There is good reason why this method should be used. Primarily, no limit is needed in bank angle which ~~would tend to make response extremely sluggish.~~ In discussing methods of integrating out errors, it was seen that the bank angle was limited to $\pm 2^\circ$. This limit would place a serious restriction on the aircraft's ability to make turns. When flying by heading alone, no artificially small limit is placed on bank angle, and only inherent maximum bank-angle characteristic of the aircraft limits the optimum responses allowed.

157. When the aircraft heading is within 15 degrees of the ordered track direction, position control is added. In this region, the combination of position control and heading control is more accurate than heading control alone. Also, the means applied to reduce the effect of error signals do not hamper the aircraft

CONFIDENTIAL

performance and maneuverability as seriously. For instance, the limited bank-angle method of reducing effect of errors, if applied to large commands, would make aircraft response prohibitively sluggish. This restriction is not as prohibitive in the 15-degree region.

158. In the region where position control is applied, the aforescribed method of limiting bank angle (± 2 degrees) is found to be the most effective. The reasons are as follows:

159. This method is least sensitive to errors (random noise) and external disturbances (winds). Responses of the limited bank angle (θ) are as good as small position control in the presence of noise only. In the presence of winds, using small values of position control is practically useless as divergence and large steady-state errors exist. With the limited bank angle, large values of position control may be used which filter through the limited bank angle to position the plane more effectively.

160. In summary, the results of this study show that the most effective way to position an aircraft in the presence of navigation errors and external disturbances are as follows:

161. (a) For large commands of ordered track, heading alone most effectively positions aircraft.

162. (2) For regions of 15 degrees around order track, the combination of heading and position control with a limited bank angle (± 2 degrees) most effectively positions aircraft.

CONFIDENTIAL

Federal Telecommunication Laboratories, Inc.

PROJECT PERFORMANCE AND SCHEDULE

Part III SUPPLEMENTARY DATA

INDEX NO. NE-011015

CONTRACT NO. NObsr- 63071

PERIOD COVERED 12/3/53 TO 3/3/54

	1953												1954					
	J	F	M	A	M	J	J	A	S	O	N	D	J	F	M			
1. Simulation of Aircraft and Autopilots																		
2. Development of Signal Generator																		
3. Generation and Reduction of Data																		

<p style="text-align: center;"><u>LEGEND</u></p> <p>▬ = WORK PERFORMED</p> <p>▬▬▬ = SCHEDULE OF PROJECTED OPERATION</p> <p>PD = PRELIMINARY DESIGN</p> <p>FD = FINAL DESIGN</p> <p>MD = MODEL TO BE DELIVERED</p> <p>T = TEST</p>	<p style="text-align: center;"><u>ESTIMATED COMPLETION</u></p> <p>1. Simulation 100%</p> <p>2. Signal Gen. 100%</p> <p>3. Data 100%</p>	<p>SHEET <u>1</u> OF <u>1</u></p>
---	---	-----------------------------------

CONFIDENTIAL

SECTION B - GLOSSARY OF TERMS FOR RATE-DATA STUDY

<u>CONCEPT</u>	<u>DESIGNATION</u>
Force	F
Moment	M
Airplane Axes	X, Y, Z
Angle of Pitch	ϵ
Angle of Yaw	ψ
Pitch Velocity	q
Roll Velocity	P
Yaw Velocity	r
Linear Velocity along X axis	u
Linear Velocity along Y axis	v
Linear Velocity along Z axis	w
Ordered Track Command	η
Force Components	F_x, F_y, F_z
Moment Coefficients	M, L, N
Elevator Hinge Moment	H_a
Rudder Hinge Moment	H_r
Coefficient of Lift	C_L
Coefficient of Drag	C_D
Normal Moment Coefficient	C_N
Rolling Moment Coefficient	C_l
Yawing Moment Coefficient	C_n
Pitching Moment Coefficient	C_m
Rolling Moment due to Yawing Velocity	C_{lr}
Yawing Moment due to Rolling Velocity	C_{np}

CONFIDENTIAL

CONFIDENTIAL

<u>CONCEPT</u>	<u>DESIGNATION</u>
Yawing Moment due to Rudder Deflection	$C_{n\delta r}$
Yawing Moment due to Rate of Rudder Deflection	$C_{n\dot{\delta} r}$
Angle of Attack	α
Angle of Sideslip	$\beta = \frac{v}{V}$
Wind Area	S_w
Wing Span	b_w
Aerodynamic Chord	c
Relative Density	$\mu = \frac{m}{\rho S b}$
Mass of Airplane	m
Air Density in (slugs/ft ³)	ρ
Dynamic Pressure in lbs per sq ft	q
Time Parameter	τ
Forward Velocity	V
Time	t
Damping Effect in Respect to Yaw	C_{nr}
Direction/Stability	$C_{n\beta}$
Rolling Moment due to Flap Deflection	$C_{l\delta a}$
Change in Rolling Moment due to Rate of Flap Deflection	$C_{l\dot{\delta} a}$
Damping Effect in Roll in Respect to Rolling Velocity	C_{lp}
Dihedral Effect	C_{lr}
Side Derivative	C_{yp}
Airplane's Inertia	I_x
Radius of Gyration about X Axis	K_x
Nondimensional Rolling Parameter	$\frac{pb}{2V}$
Autopilot Gain Factor	K_A
Position Gain Factor	K_S

CONFIDENTIAL

CONFIDENTIAL

<u>CONCEPT</u>	<u>DESIGNATION</u>
Computer Junction Unit	A
Computer Coefficient Unit	C
Computer Integrator Unit	J
Computer Bounding Unit	B
Acceleration Components along and about Fixed Axes x, y, z	a_x, a_y, a_z
Angular Momentum along and about Fixed Axes x, y, z	H_x, H_y, H_z
Components of Angular Velocity ω about Axes o_x, o_y, o_z (also see)	$\omega_x, \omega_y, \omega_z$ p, q, r
Components of the Rates of Volume Variation of Angular Momentum along and about $o_x, o_y,$ and o_z Axis	dh_x, dh_y, dh_z

SECTION C - ILLUSTRATIONS

<u>Fig. No.</u>	<u>Title</u>
1	Block Diagram of Components for Rate Data Study (RX-408844-1)
2	Airplane's Six Degrees of Freedom and Moments of Momentum (RX-408847-1)
3	Acceleration Components and Moment of Momentum (RX-408848-1)
4	Axis System for Lateral Dynamics, Airplane Lateral Force (RX-408849-1)
5	Philbrick Computer Configuration for Lateral Dynamic Equations (RX-407943-2A)
6	Lateral Mode Simplified Circuit (RX-408032-2A)
7	Graphic Display of the Function of the Transmission System Simulator (RX-408846-1)
8	Transmission System Simulator Circuit (RX-408131-14B)
9	Determination of Rate of Deflection (RX-408843-1)
10	Lateral Configuration on Philbrick Computer for Obtaining Flight Path Data (RX-408778-2A)
11	Graphic Representation of Ordered Track and Flight Path Configura- tion as Used in System Evaluation (RX-408845-1)

CONFIDENTIAL

CONFIDENTIAL

<u>Fig. No.</u>	<u>Title</u>
12	Aircraft Responses. No Limits, No Noise
13	Aircraft Responses Bank Angle Limited ± 2 Degrees, No Noise
14	Rate of Turn in Coordinated Turns (RX-408842-1)
15	Aircraft Responses Small K_{δ} Noise Magnitude Equivalent to 50 Miles
16	Aircraft Responses, Small K_{δ} , No Noise
17	Aircraft Responses Bank Angle Limited ± 2 Degrees, Noise Magnitude Equivalent to 50 Miles
18	Aircraft Responses Small K_{δ} , Noise Magnitude Equivalent to 200 Miles
19	Aircraft Responses Bank Angle Limited ± 2 Degrees, Noise Magnitude Equivalent to 200 Miles
20	Aircraft Responses Bank Angle Limited ± 2 Degrees, 10-Knot Crosswind
21	Aircraft Responses, Small K_{δ} , 10-Knot Crosswind

CONFIDENTIAL

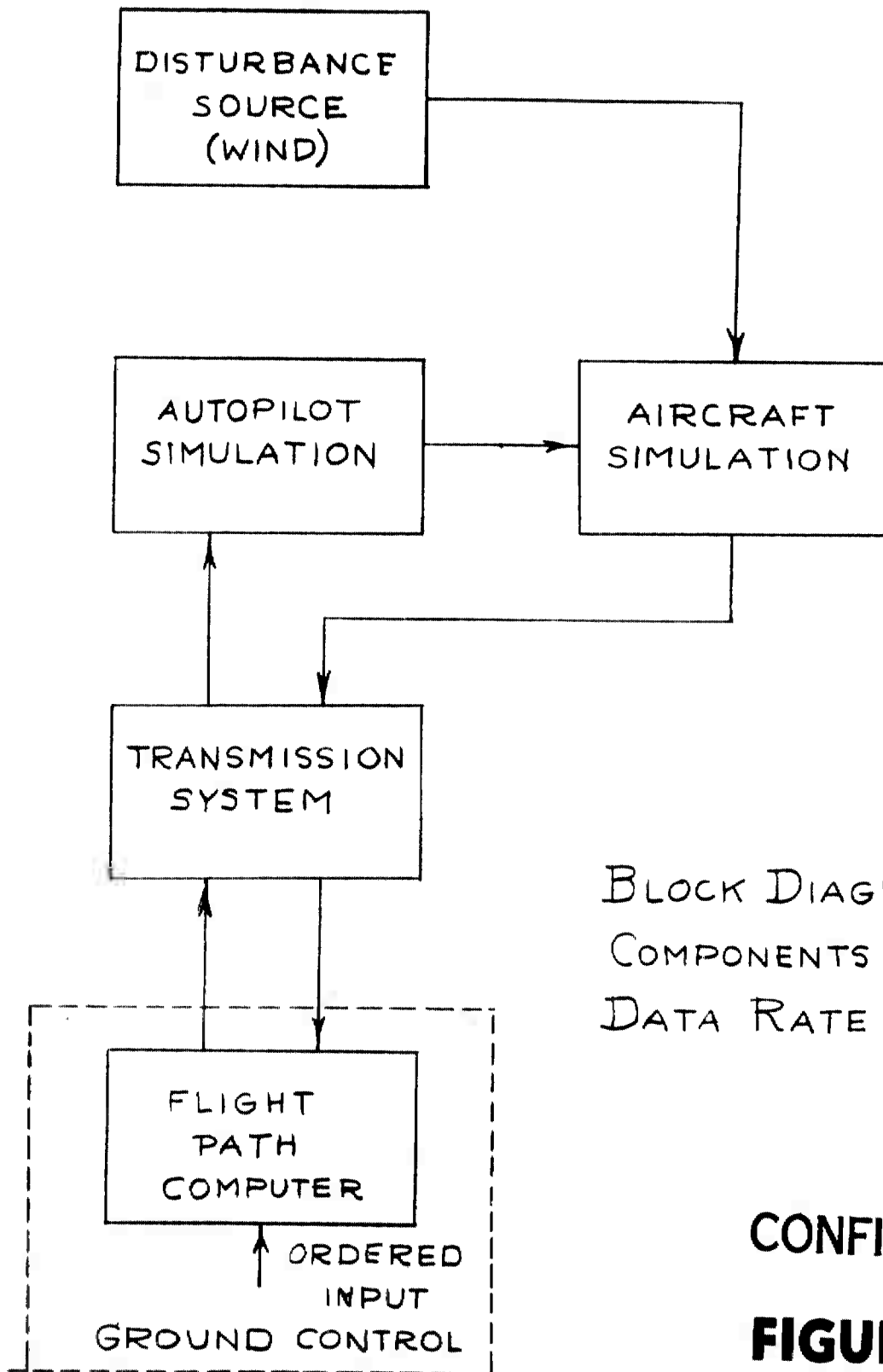

BLOCK DIAGRAM OF COMPONENTS FOR DATA RATE STUDY

CONFIDENTIAL

FIGURE 1

NO 657 63071 F

TOLERANCE UP TO 8 ABOVE 8 TO 24 ABOVE 24 DEC. DIM. $\pm .008$ $\pm .010$ $\pm .012$ FRACT. DIM. $\pm \frac{1}{64}$ $\pm \frac{1}{32}$ $\pm \frac{1}{16}$ UNLESS OTHERWISE SPECIFIED		MATERIAL		TITLE STUDY COMPONENTS			
FINISH		ISSUED	USED WITH	APP'D	DWN.		
Federal Telecommunication Laboratories, Inc.				RX-408844 -1			

NO 657 63071 F

(A)

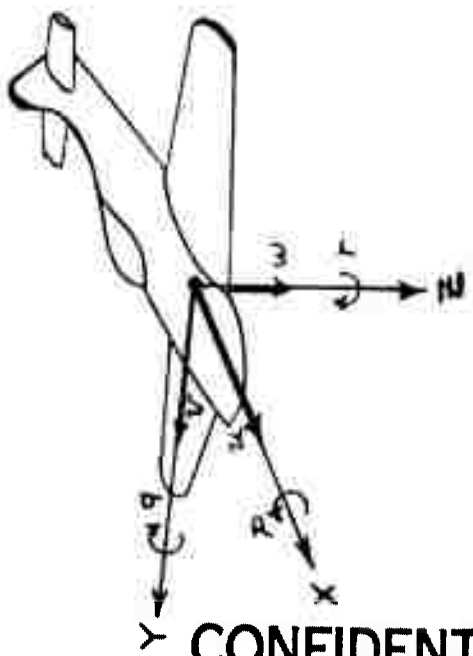

THE AIRPLANE'S SIX DEGREES OF FREEDOM

(B)

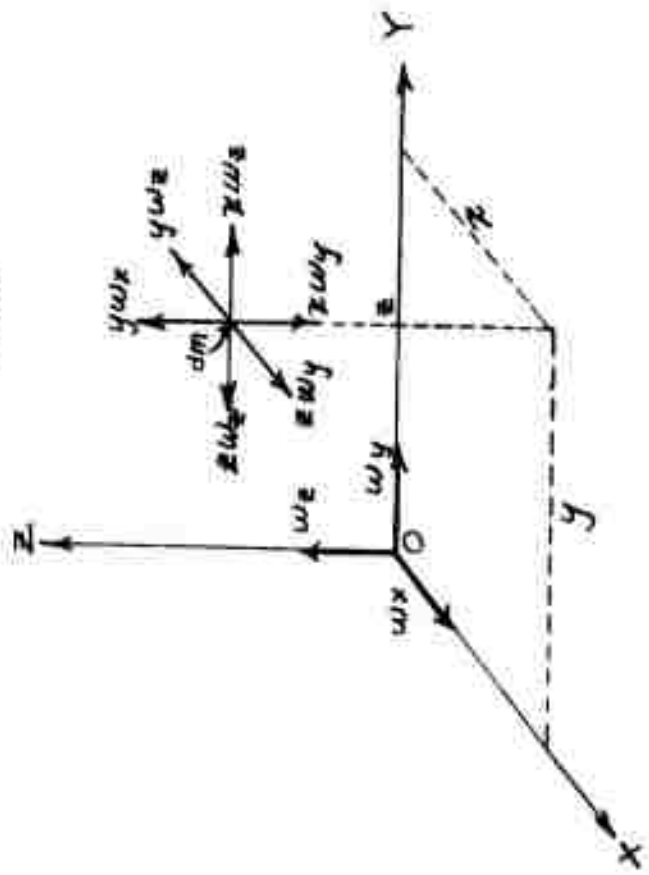

ANGULAR MOMENTUM OF dm

CONFIDENTIAL

FIGURE 2

TOLERANCE UP TO 6 ABOVE 6 TO 24 ABOVE 24 DEC. DIM. $\pm .008$ $\pm .010$ $\pm .015$ FRACT. DIM. $\pm \frac{1}{64}$ $\pm \frac{1}{32}$ $\pm \frac{1}{16}$ UNLESS OTHERWISE SPECIFIED	MATERIAL		TITLE MOMENT CONFIGURATION			
	FINISH		ISSUED	USED WITH	APP'D	DWN.
Federal Telecommunication Laboratories, Inc.					RX-408847-1	

CONFIDENTIAL

NO. 6-3071 F

(A)

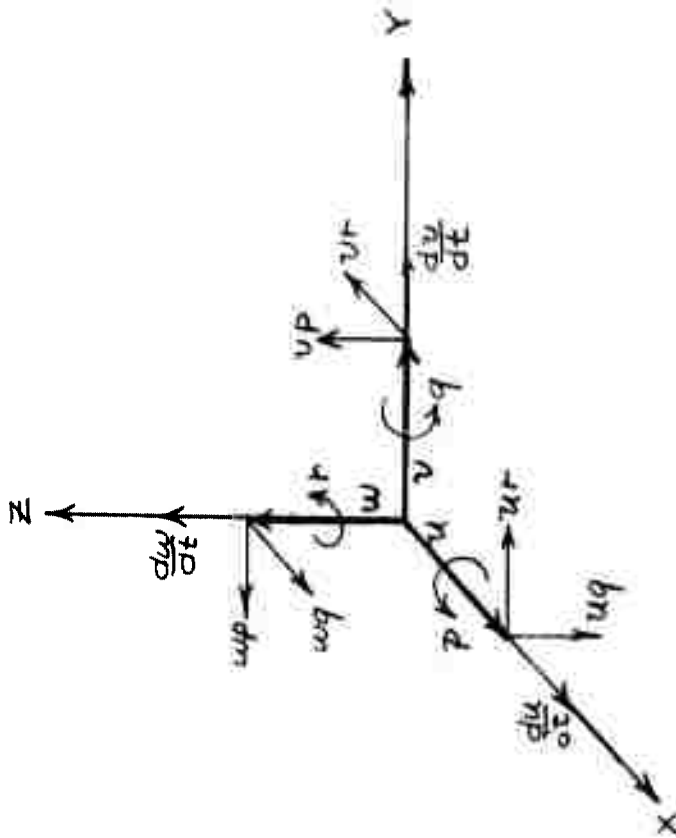

ACCELERATION COMPONENTS
REFERRED TO MOVING AXES.

(B)

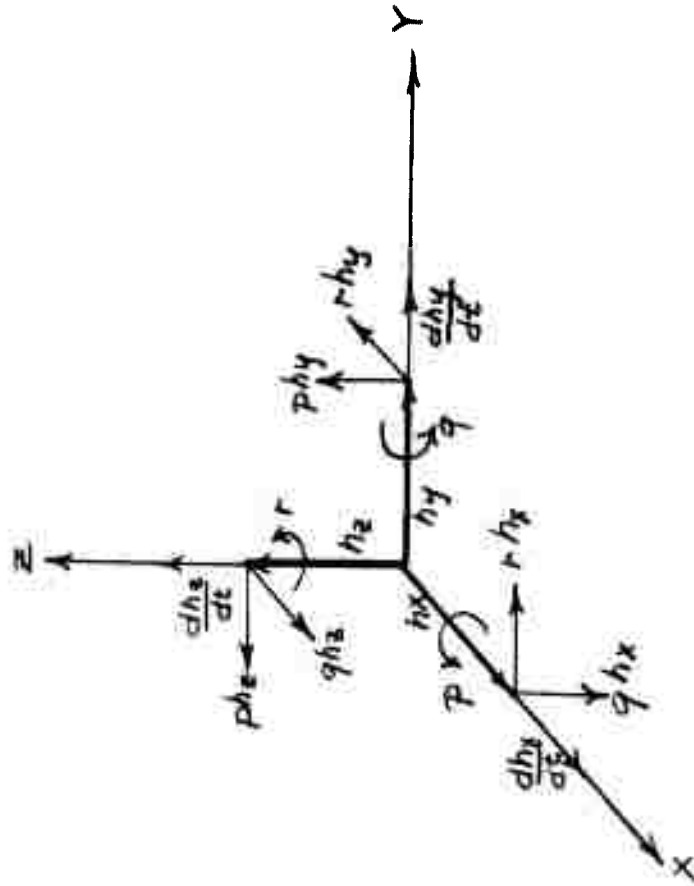

CONFIDENTIAL

ANGULAR MOMENTUM
REFERRED TO MOVING AXES

FIGURE 3

CONFIDENTIAL

TOLERANCE UP TO 6 ABOVE 6 TO 24 ABOVE 24 DEC. DIM. ±.008 ±.010 ±.018 FRACT. DIM. ± 1/64 ± 1/32 ± 1/16 UNLESS OTHERWISE SPECIFIED	MATERIAL		TITLE ACCELERATIONS & MOMENTS			
	FINISH		ISSUED	USED WITH	APPD	DWN.
Federal Telecommunication Laboratories, Inc.					RX-408848 -1	

CONFIDENTIAL

THE AIRPLANE LATERAL FORCE, LEVEL FLIGHT

FIGURE 4

AXIS SYSTEM FOR LATERAL DYNAMICS

CONFIDENTIAL

(B)

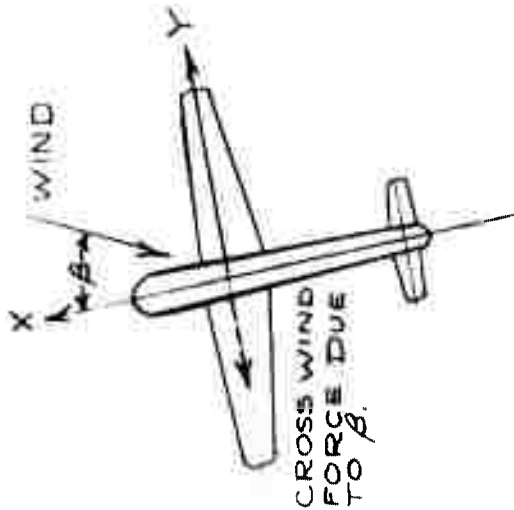
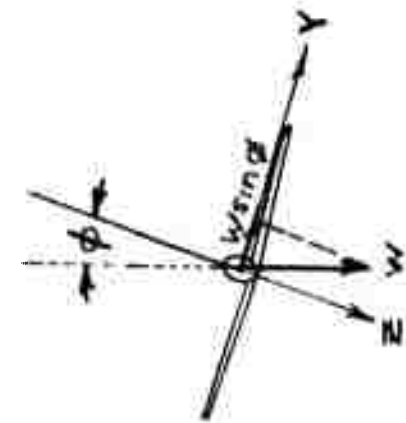

(A)

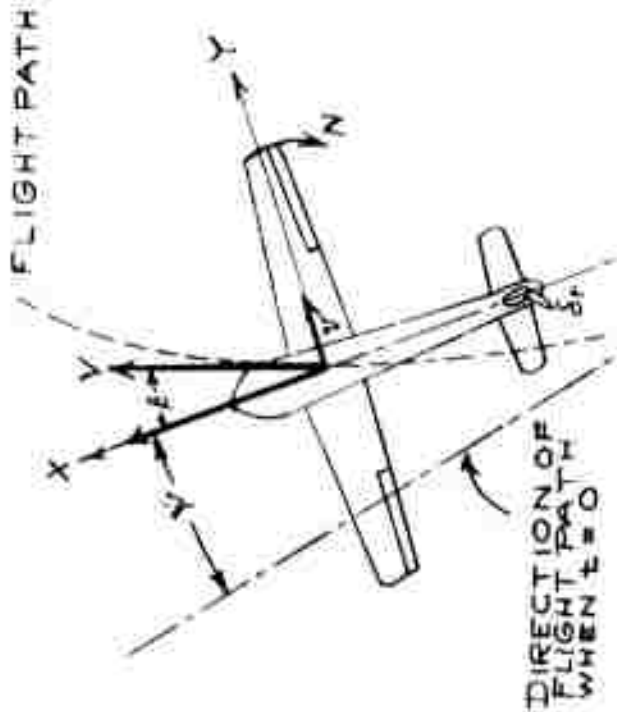

<p>TOLERANCE</p> <p>UP TO 6 ABOVE 6 TO 24 ABOVE 24</p> <p>DEC. DIM. ±.005 ±.010 ±.015</p> <p>FRACT. DIM. ± 1/64 ± 1/32 ± 1/16</p> <p>UNLESS OTHERWISE SPECIFIED</p>			<p>MATERIAL</p>		<p>TITLE</p> <p>LATERAL SYSTEM</p>			
<p>FINISH</p>			<p>ISSUED</p>		<p>USED WITH</p>		<p>AP'PD</p>	<p>DWN.</p>
<p>Federal Telecommunication Laboratories, Inc.</p>							<p>RX-408849 -1</p>	

FTL FORM NO. 100-2

LATERAL MOTION

- (1.) $(C_{y\beta} - 2d)\beta - 2d\psi + CL\phi$
- (2.) $\mu C_{L\beta}\beta + \frac{C_{Lr}}{2}r + \left[\frac{C_{Lp}}{2}\rho\right]$
- (3.) $\mu C_{n\beta}\beta + \left[\frac{C_{nr}}{2} - 2\left(\frac{K_B}{B}\right)^2\right]$

CONFIDENTIAL

SIDE VELOCITY

LEGEND



ϕ BANK ANGLE IN RADIAN



HEADING CHANGE FROM $T=0$ IN RADIAN

β - ANGLE C

ϕ - ANGLE C

ψ - ANGLE C

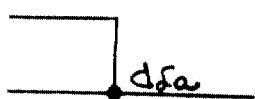

CONFIDENTIAL

THESE DRAWINGS AND SPECIFICATIONS ARE THE PROPERTY OF APPARATUS WITHOUT PERMISSION.

A ORIGINAL ISSUE

REVISIONS

Federal Telecommunication Laboratories, Inc.
NUTLEY, N. J., U. S. A.

PHILBRICK COMPUTER LATERAL
DYNAMIC EQUATIONS

MATERIAL

FINISH

FIGURE -5

M DATE

4-28-53

APPD.

RX-407943-2

ISSUE

DEPLANCE NO. 107H

NO 55r 43071

CONFIDENTIAL

RX-407943-2
DRAWING NO.

LATERAL MOTION EQUATIONS

(1) $(C_{\beta} - 2d)\beta - 2d\dot{\psi} + C_L\dot{\phi} = 0$
 (2) $\mu C_{\beta}\dot{\beta} + \frac{C_{\beta}}{2}r\dot{\psi} + [\frac{C_{\beta}}{2}d - 2(\frac{K_x}{b})^2 d^2]\dot{\phi} + \mu(C_{\beta}a + C_{\beta}d\dot{s}a)d\dot{s}a = 0$
 (3) $\mu C_{\eta}\dot{\beta} + [\frac{C_{\eta}}{2} - 2(\frac{K_x}{b})^2 d]\dot{\psi} + \frac{C_{\eta}}{2}d\dot{\phi} + \mu(C_{\eta}r + C_{\eta}d\dot{s}r)d\dot{s}r = 0$

LEGEND

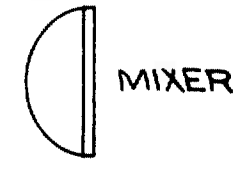

MIXER



INTEGRATOR



MULTIPLIER

β - ANGLE OF SIDESLIP
 ϕ - ANGLE OF BANK
 ψ - ANGLE OF YAW

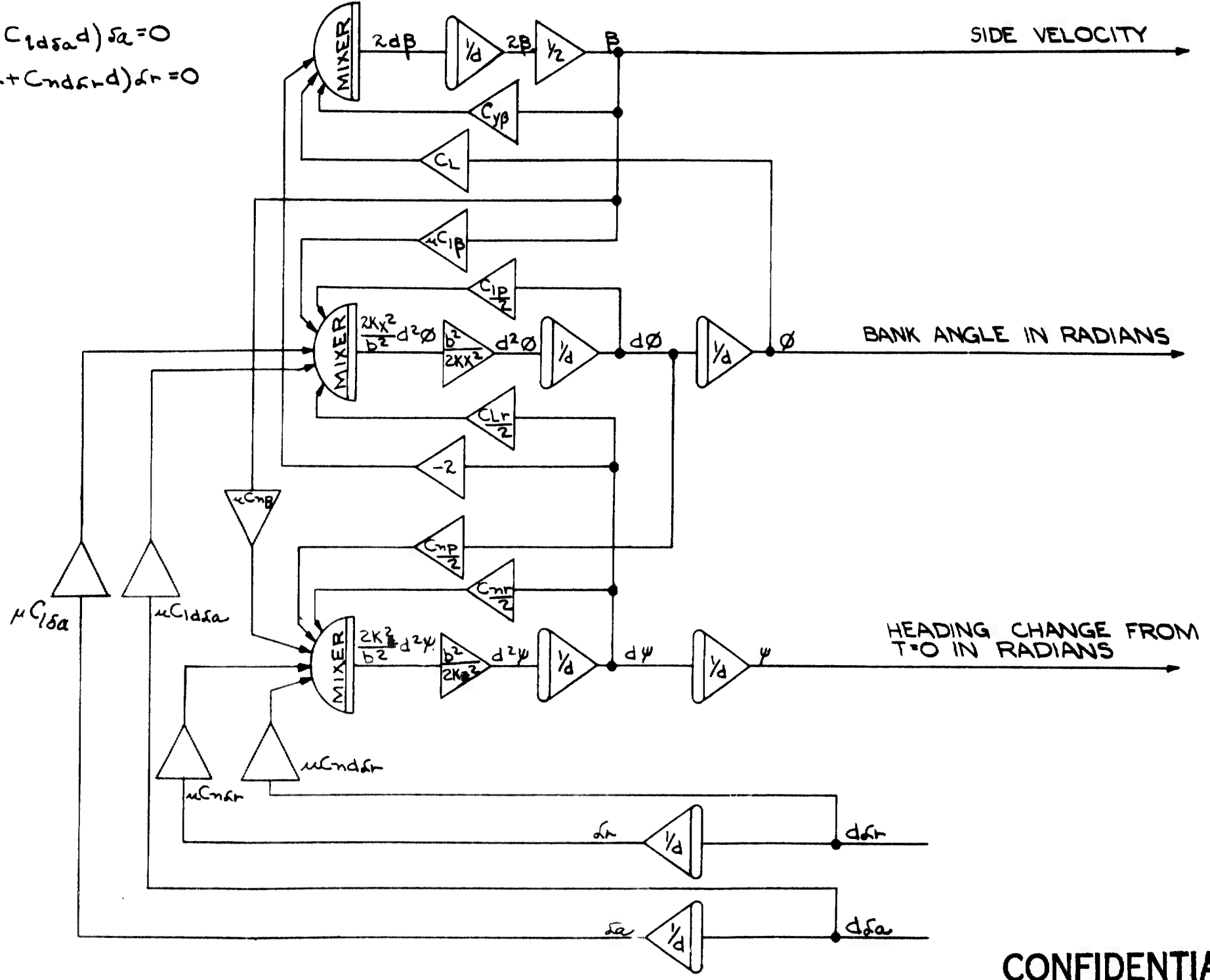

CONFIDENTIAL

THESE DRAWINGS AND SPECIFICATIONS ARE THE PROPERTY OF FEDERAL TELECOMMUNICATION LABORATORIES, INC., ARE ISSUED IN STRICT CONFIDENCE AND SHALL NOT BE REPRODUCED, OR COPIED, OR USED AS THE BASIS FOR THE MANUFACTURE OR SALE OF APPARATUS WITHOUT PERMISSION.

A ORIGINAL ISSUE
REVISIONS

UNLESS OTHERWISE SPECIFIED		
ALL DIMENSIONS IN INCHES		
TOLERANCES		
BASIC DIM.	FRACTIONS	DECIMALS
UNDER 6	± 1/4	± .008
6 TO 24 INCL.	± 1/32	± .010
OVER 24	± 1/16	± .015
ANGLES ±	ECCENTRICITY	TIR.
HOLE DIA. ±	SURFACES	✓
COMMERCIAL TOLERANCES APPLY TO STOCK SIZES		

FIRST USED ON	NEXT ASSEMBLY	BILL OF MATERIAL
SCALE	CHG'D.	DES. ENG.
DRAWN J. PAVELCHAK	ENG.	E OF M

Federal Telecommunication Laboratories, Inc. MUTLEY, N. J., U. S. A.	
PHILBRICK COMPUTER LATERAL DYNAMIC EQUATIONS	
MATERIAL	
FINISH	
FIGURE -5	
DATE 4-28-53	RX-407943-2 A
APPD.	

NO. 63071

CONFIDENTIAL

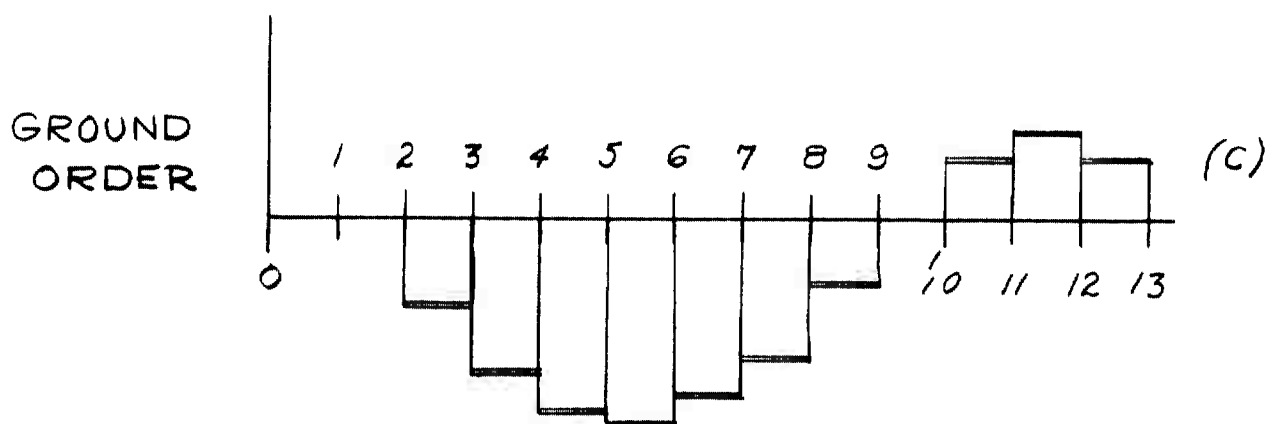
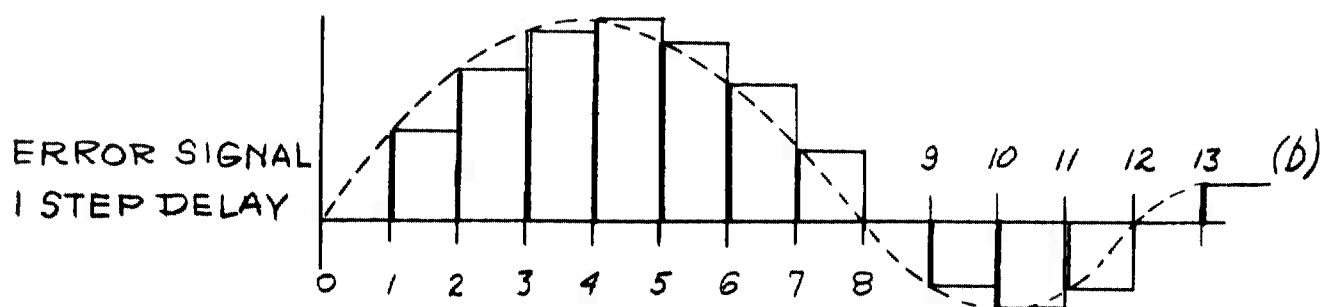
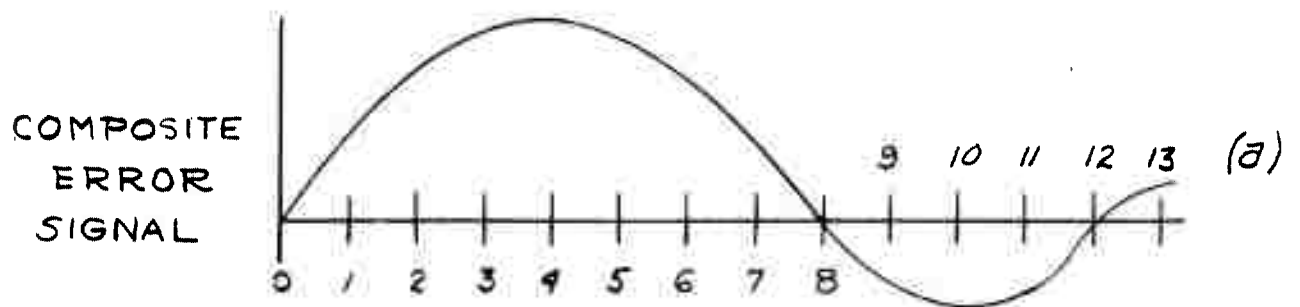

CONFIDENTIAL

GRAPHIC DISPLAY OF THE FUNCTION OF THE TRANSMISSION SYSTEM SIMULATOR

FIGURE 7

<p>TOLERANCE</p> <table border="1"> <tr> <td></td> <td>UP TO 6</td> <td>ABOVE 6 TO 24</td> <td>ABOVE 24</td> </tr> <tr> <td>DEC. DIM.</td> <td>±.008</td> <td>±.010</td> <td>±.018</td> </tr> <tr> <td>FRACT. DIM.</td> <td>± 1/64</td> <td>± 1/32</td> <td>± 1/16</td> </tr> </table> <p>UNLESS OTHERWISE SPECIFIED</p>		UP TO 6	ABOVE 6 TO 24	ABOVE 24	DEC. DIM.	±.008	±.010	±.018	FRACT. DIM.	± 1/64	± 1/32	± 1/16	MATERIAL		TITLE TRANSMISSION SYSTEM			
		UP TO 6	ABOVE 6 TO 24	ABOVE 24														
DEC. DIM.	±.008	±.010	±.018															
FRACT. DIM.	± 1/64	± 1/32	± 1/16															
	FINISH		ISSUED	USED WITH	APP'D	DWN.												
Federal Telecommunication Laboratories, Inc.					RX-408846-1													

N° 07 (507) 5

DRAWING NO. RX408131-14

A ORIGINAL ISSUE	
REVISIONS	
REDESIGNED	B
J.P. 10-7-53	

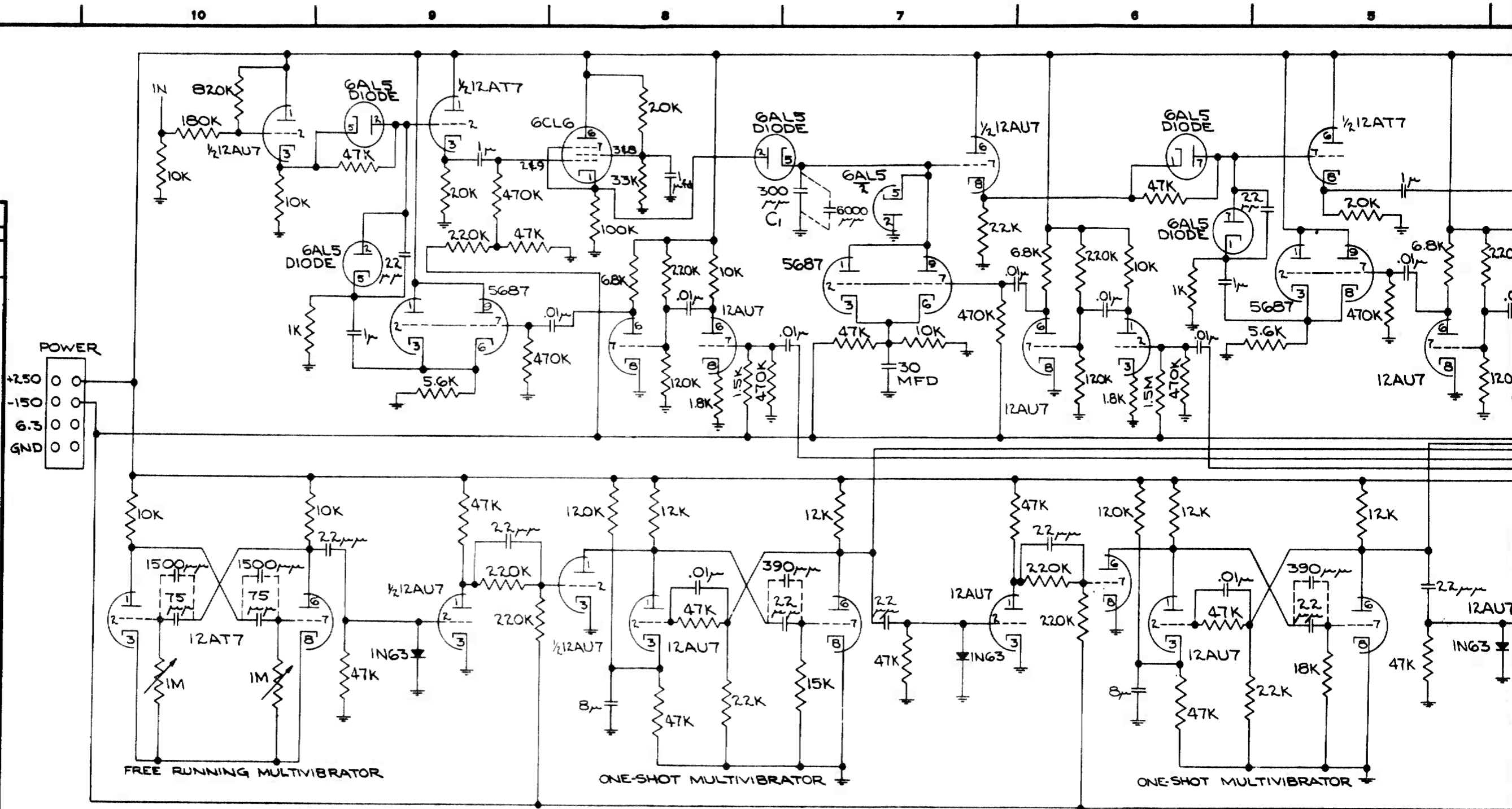

DETERMINATION OF RATE OF DEFLECTION ($\dot{\delta}$)

CONFIDENTIAL

LEGEND:

- u forward velocity (ft/sec)
- v sideslip velocity (ft/sec)
- η command signal (in degrees)
- ψ heading angle (in degrees)
- $\dot{\delta}$ rate of deflection (ft/sec)
- $\alpha = \eta - \psi$

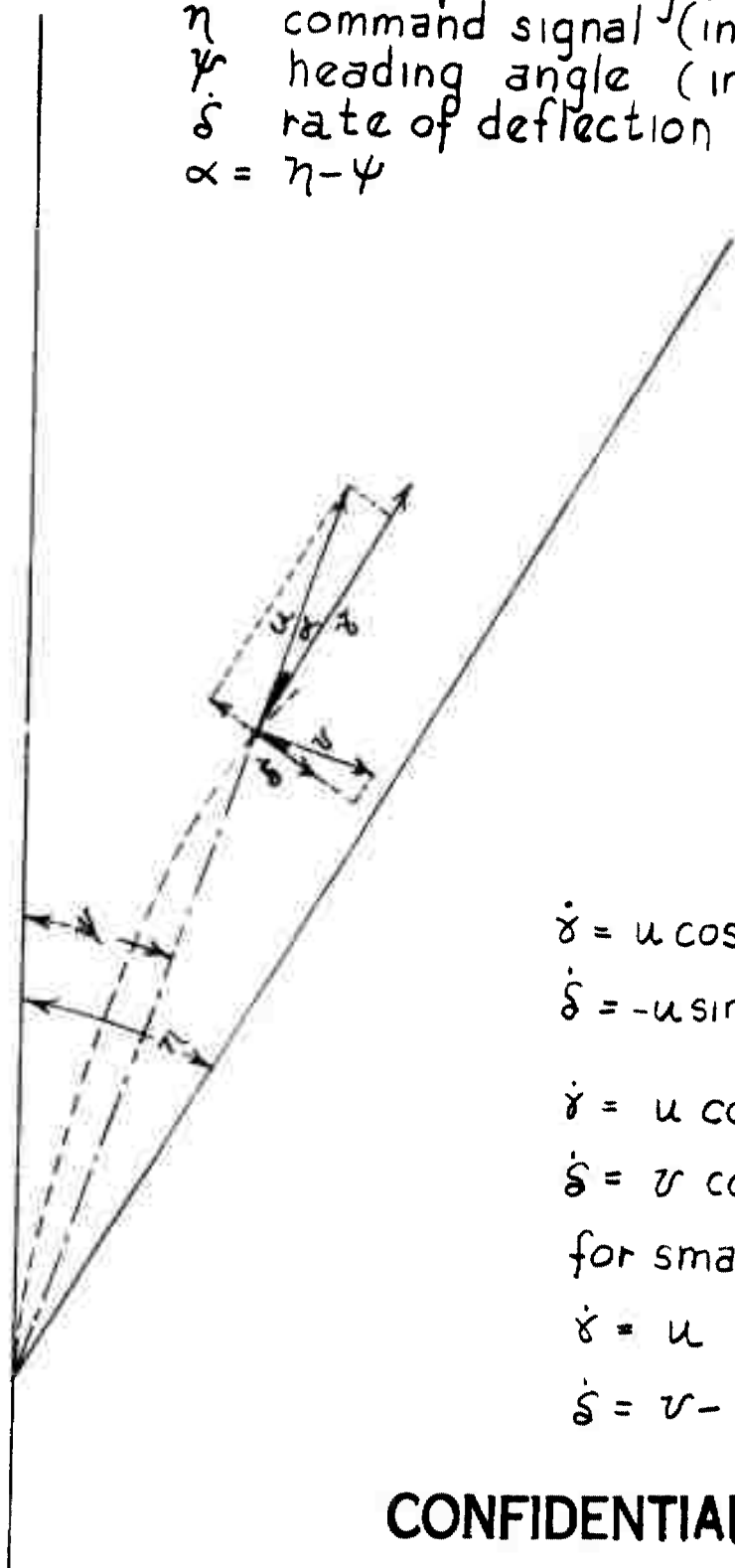

$$\dot{\delta} = u \cos(\eta - \psi) + v \sin(\eta - \psi)$$

$$\dot{\delta} = -u \sin(\eta - \psi) + v \cos(\eta - \psi)$$

$$\dot{\delta} = u \cos(\eta - \psi)$$

$$\dot{\delta} = v \cos(\eta - \psi) - u(\eta - \psi)$$

for small values of $(\eta - \psi)$

$$\dot{\delta} = u$$

$$\dot{\delta} = v - u(\eta - \psi)$$

CONFIDENTIAL FIGURE 9

NCHSR 63071 F

TOLERANCE UP TO ABOVE ABOVE 6 6 TO 24 24 DEC. DIM. $\pm .005$ $\pm .010$ $\pm .015$ FRACT. DIM. $\pm \frac{1}{64}$ $\pm \frac{1}{32}$ $\pm \frac{1}{16}$ UNLESS OTHERWISE SPECIFIED	MATERIAL		TITLE $\dot{\delta}$ DETERMINATION			
	FINISH		ISSUED	USED WITH	APP'D	DWN.
Federal Telecommunication Laboratories, Inc.					RX-408843-1	

RX-408778-2
DRAWING NO.

CONFIDENTIAL

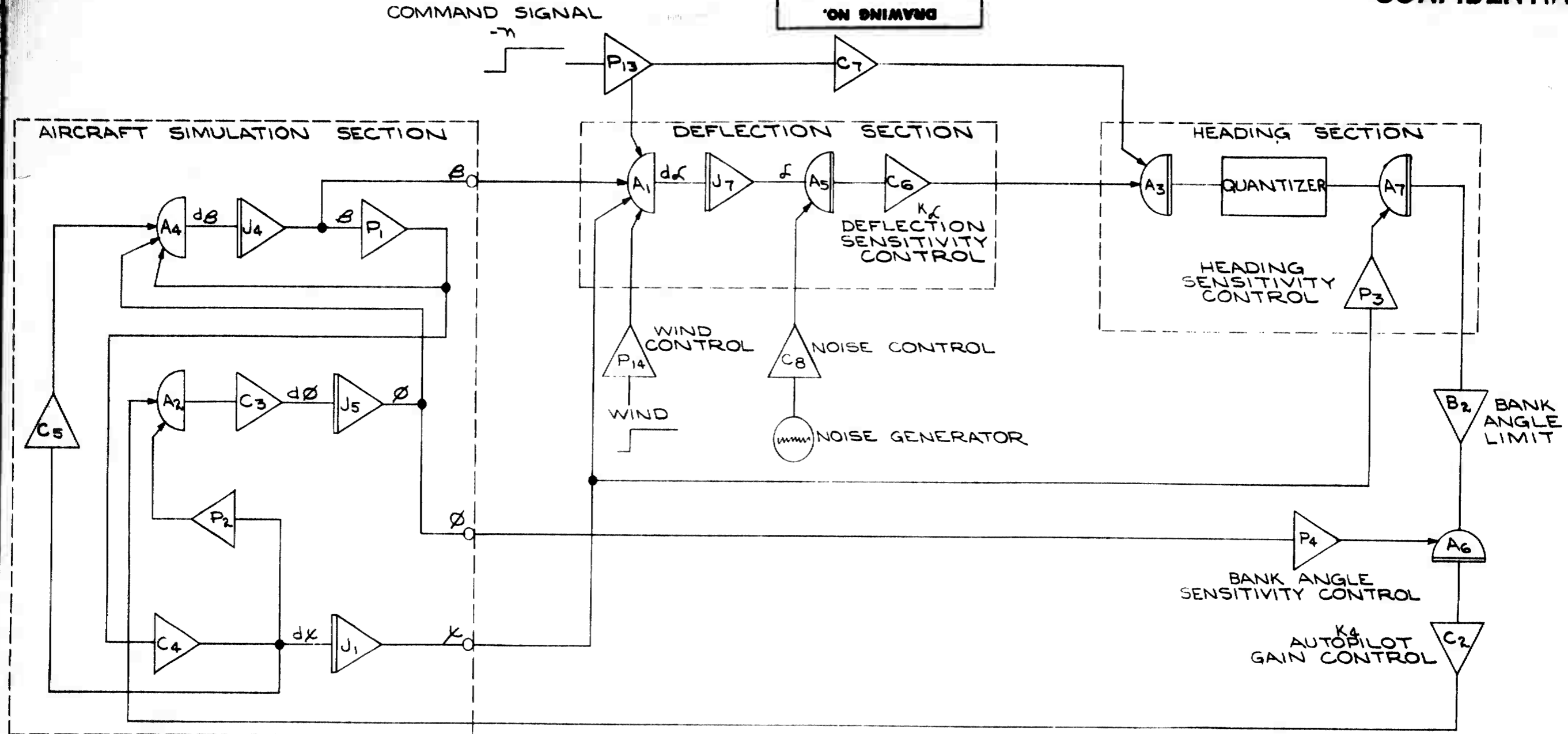

LEGEND:

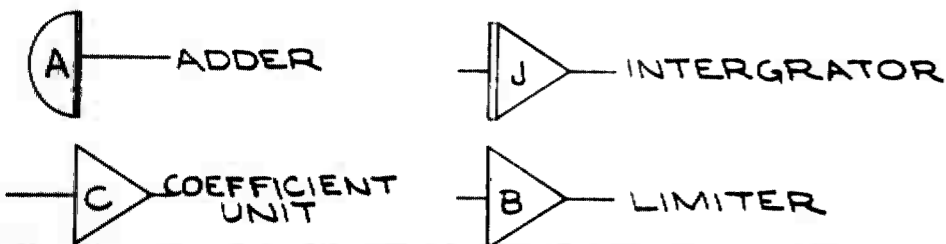

TERMS:
 B = SIDESLIP ANGLE
 Ø = BANK ANGLE
 K = HEADING ANGLE
 ℓ = DEFLECTION IN FT.
 dℓ = RATE OF DEFLECTION IN FT./SEC.
 η = COMMAND SIGNAL

CONFIDENTIAL

THESE DRAWINGS AND SPECIFICATIONS ARE THE PROPERTY OF FEDERAL TELECOMMUNICATION LABORATORIES AND ARE ISSUED IN STRICT CONFIDENCE AND SHALL NOT BE REPRODUCED, OR COPIED, OR USED AS THE BASIS FOR THE MANUFACTURE OR SALE OF APPARATUS WITHOUT PERMISSION.

ITEM NO.	DWS. SIZE	PART NUMBER	PART DESCRIPTION	UNIT QUANTITY PER ASSEMBLY										U OF M	SOURCE																							
				-1	-2	-3	-4	-5	-6	-7	-8	-9																										
UNLESS OTHERWISE SPECIFIED				Federal Telecommunication Laboratories											NUTLEY, N. J., U. S. A.																							
ALL DIMENSIONS IN INCHES				NEXT ASSEMBLY		BILL OF MATERIAL		LATERAL CONFIGURATION ON PHILBRICK COMPUTER FOR OBTAINING FLIGHT PATH DATA MATERIAL						FINISH																								
TOLERANCES				<table border="1"> <tr> <th>BASIC DIM.</th> <th>FRACTIONS</th> <th>DECIMALS</th> </tr> <tr> <td>UNDER 6</td> <td>± 1/64</td> <td>± .005</td> </tr> <tr> <td>6 TO 24 INCL.</td> <td>± 1/32</td> <td>± .010</td> </tr> <tr> <td>OVER 24</td> <td>± 1/16</td> <td>± .015</td> </tr> </table>											BASIC DIM.	FRACTIONS	DECIMALS	UNDER 6	± 1/64	± .005	6 TO 24 INCL.	± 1/32	± .010	OVER 24	± 1/16	± .015	SCALE		DATE		DRAWN		DES.		E OF M		DATE	
BASIC DIM.	FRACTIONS	DECIMALS																																				
UNDER 6	± 1/64	± .005																																				
6 TO 24 INCL.	± 1/32	± .010																																				
OVER 24	± 1/16	± .015																																				
HOLE DIA. ±				DRAWN J. PAVELCHAK		2-19-54		ENG.		SUBJECT		RX-408778-2		A																								
COMMERCIAL TOLERANCES APPLY TO STOCK SIZES				SCALE		DATE		DES.		E OF M		DATE		A																								

A GENERAL ISSUE REVISIONS

6 5 4 3 2 1

CONFIDENTIAL

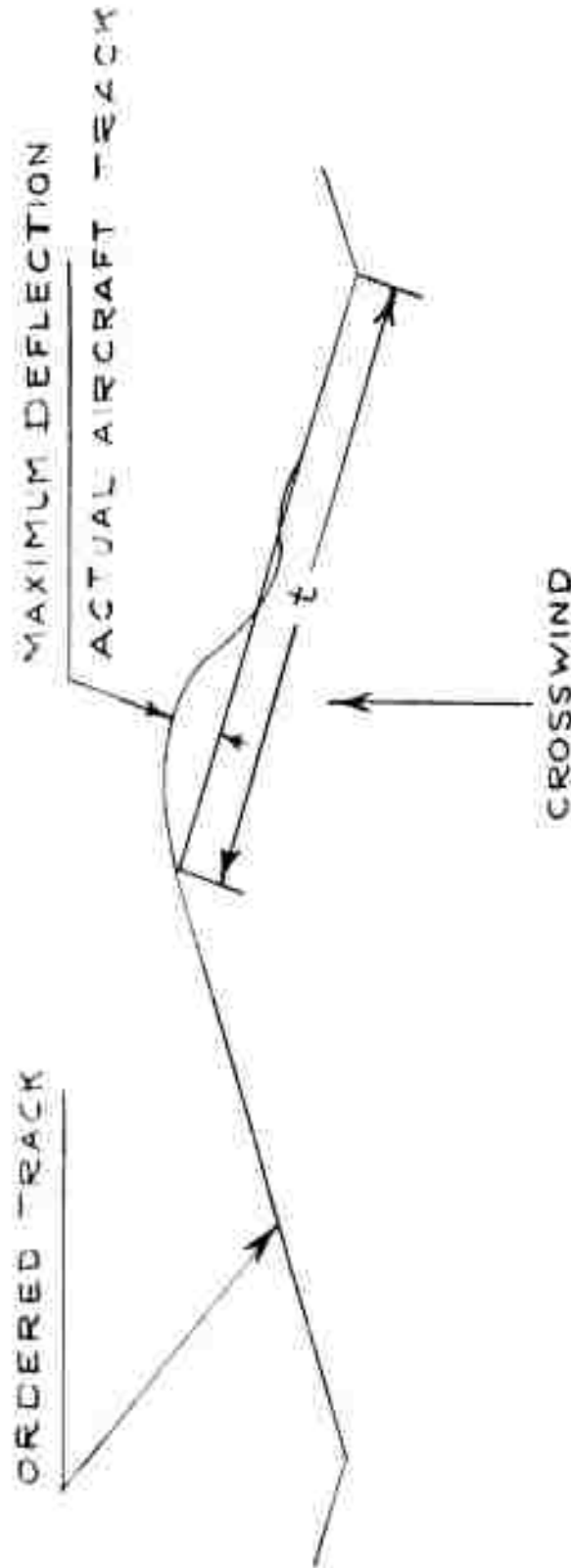

GRAPHIC REPRESENTATION OF ORDERED TRACK
AND FLIGHT PATH CONFIGURATIONS AS
USED IN SYSTEM EVALUATION

CONFIDENTIAL

FIGURE 11

<p>TOLERANCE</p> <p>UP TO 6 ABOVE 6 TO 24 ABOVE 24</p> <p>DEC. DIM. $\pm .005$ $\pm .010$ $\pm .015$</p> <p>FRACT. DIM. $\pm \frac{1}{64}$ $\pm \frac{1}{32}$ $\pm \frac{1}{16}$</p> <p>UNLESS OTHERWISE SPECIFIED</p>	<p>MATERIAL</p>		<p>TITLE</p> <p>TRACK CONFIGURATION</p>			
	<p>FINISH</p>		<p>ISSUED</p>	<p>USED WITH</p>	<p>APP'D</p>	<p>DWN.</p>
<p><i>Federal Telecommunication Laboratories, Inc.</i></p>					<p>RX-408845-1</p>	

CONFIDENTIAL

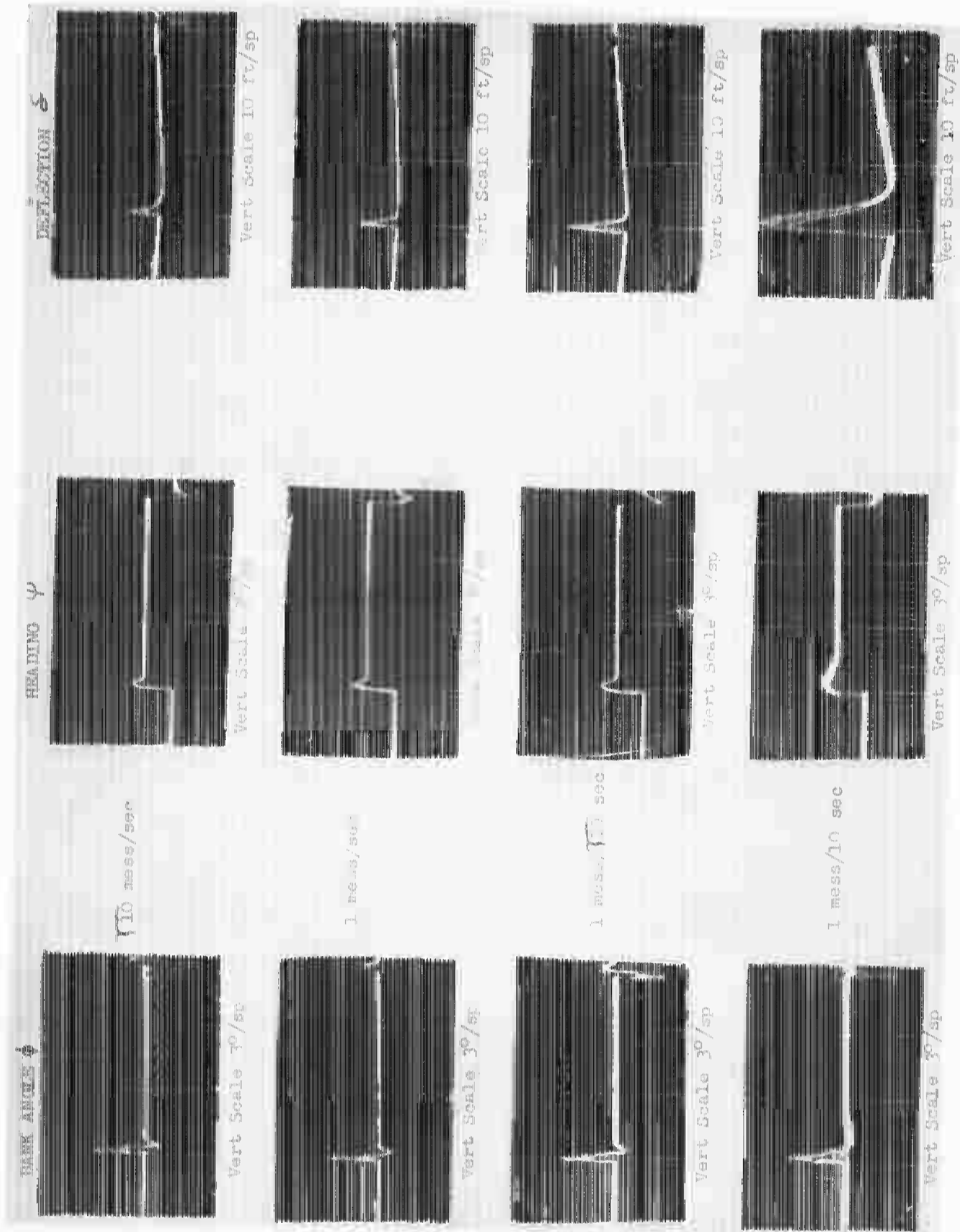

FIGURE 12 - AIRCRAFT RESPONSES TO HEADING ORDER OF 15°, NO LIMITS, NO NOISE, TIME SCALE: 2 MIN PER LARGE SQUARE

CONFIDENTIAL

CONFIDENTIAL

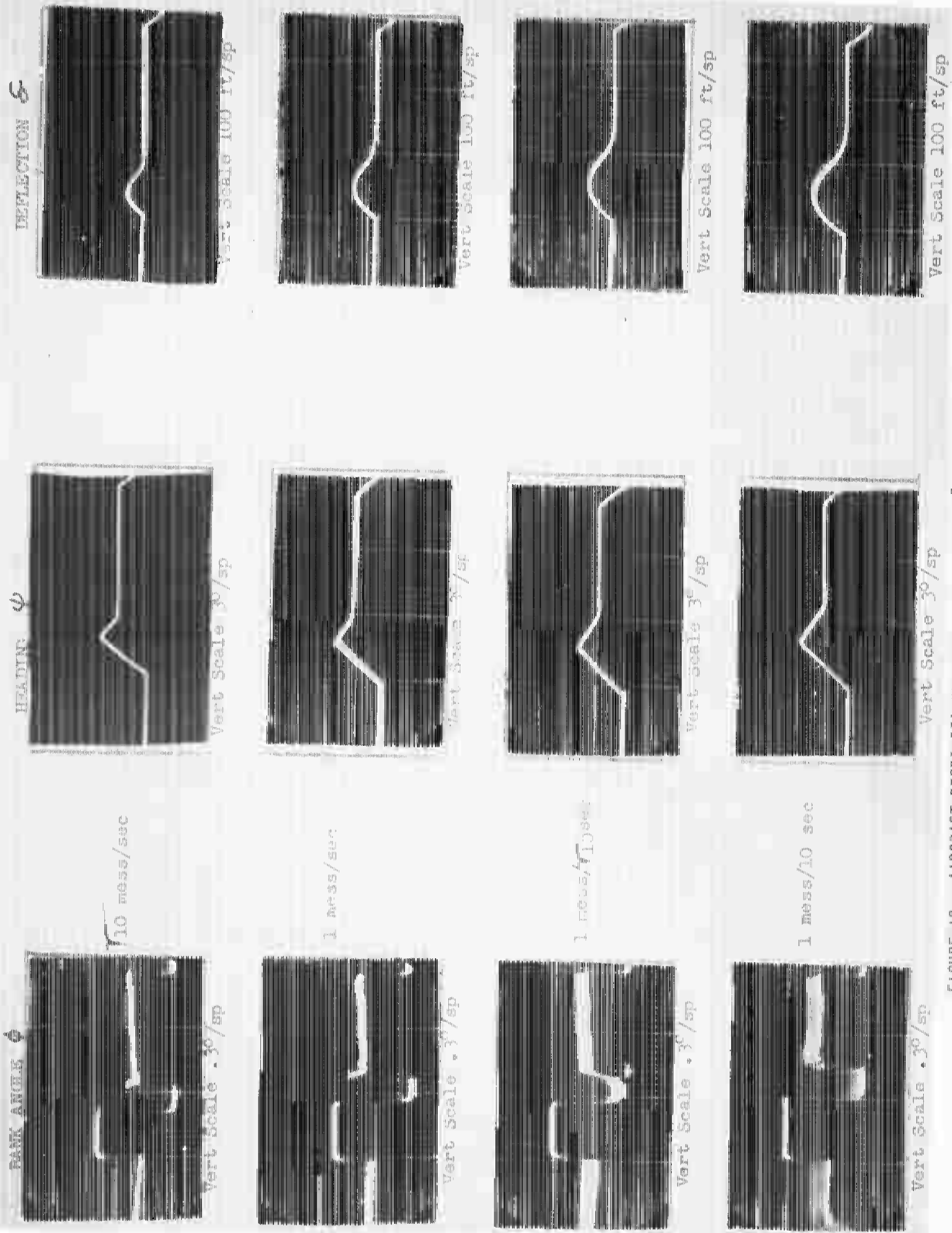
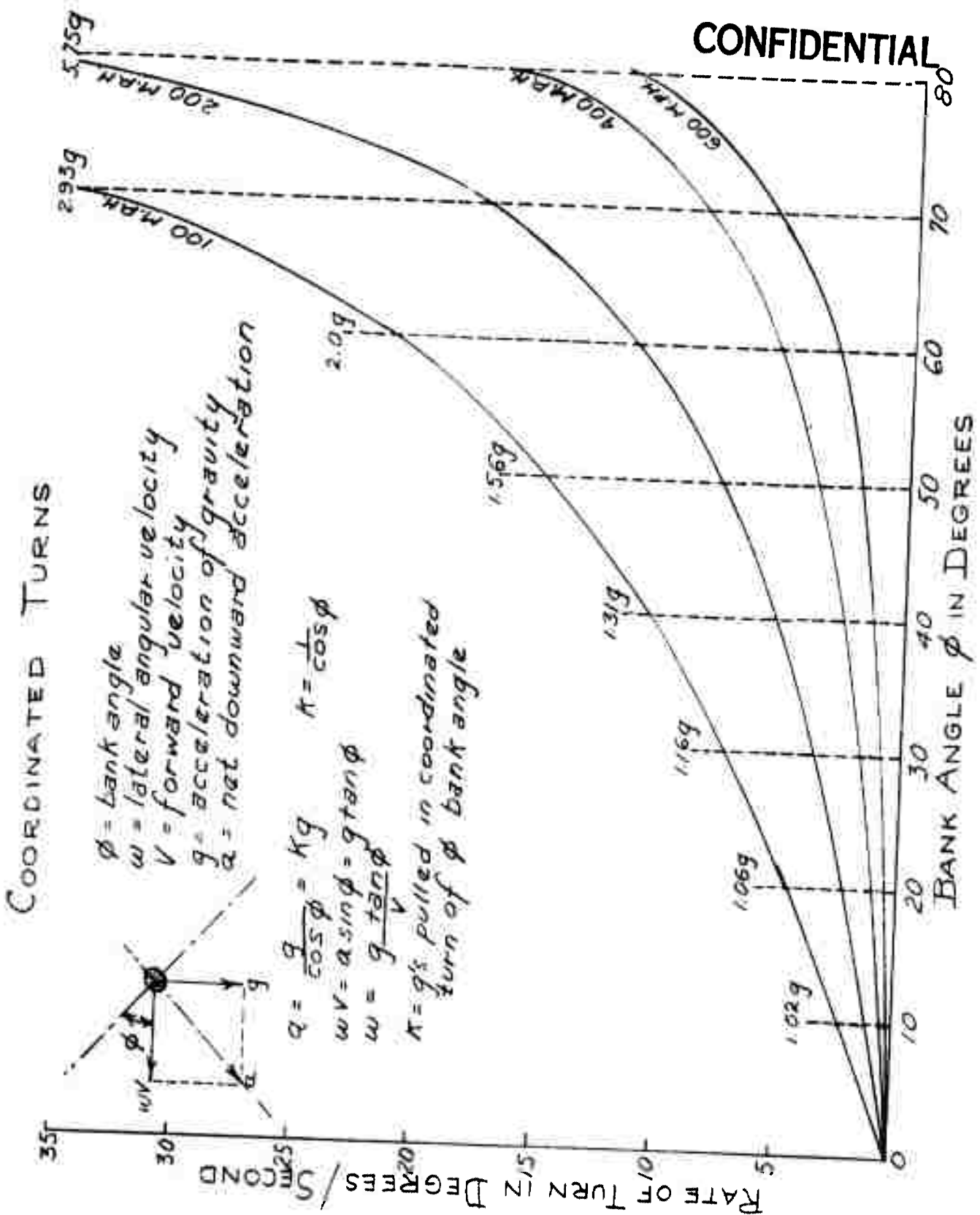

FIGURE 13 - AIRCRAFT RESPONSES TO HEADING ORDER OF 15° , LIMITED $\phi \pm 2^\circ$, NO NOISE, TIME SCALE: 2 MIN PER LARGE SQUARE

CONFIDENTIAL

11-11-54



CONFIDENTIAL FIGURE 14

<p style="text-align: center; margin: 0;">TOLERANCE</p> <table style="width: 100%; border-collapse: collapse; font-size: small;"> <tr> <td style="width: 33%;"></td> <td style="width: 33%; text-align: center;">UP TO</td> <td style="width: 33%; text-align: center;">ABOVE</td> </tr> <tr> <td style="text-align: center;">DEC. DIM.</td> <td style="text-align: center;">$\pm .008$</td> <td style="text-align: center;">$\pm .010$</td> </tr> <tr> <td style="text-align: center;">FRACT. DIM.</td> <td style="text-align: center;">$\pm \frac{1}{64}$</td> <td style="text-align: center;">$\pm \frac{1}{32}$</td> </tr> </table> <p style="margin: 0; font-size: x-small;">UNLESS OTHERWISE SPECIFIED</p>		UP TO	ABOVE	DEC. DIM.	$\pm .008$	$\pm .010$	FRACT. DIM.	$\pm \frac{1}{64}$	$\pm \frac{1}{32}$	<p style="margin: 0;">MATERIAL</p> <hr/> <p style="margin: 0;">FINISH</p>	<p style="text-align: center; margin: 0;">TITLE</p> <p style="text-align: center; font-size: large; margin: 0;">RATE OF TURN</p> <table style="width: 100%; border-collapse: collapse; font-size: x-small; margin-top: 5px;"> <tr> <td style="width: 25%;">ISSUED</td> <td style="width: 25%;">USED WITH</td> <td style="width: 25%;">APPRO</td> <td style="width: 25%;">DWN</td> </tr> </table>	ISSUED	USED WITH	APPRO	DWN
	UP TO	ABOVE													
DEC. DIM.	$\pm .008$	$\pm .010$													
FRACT. DIM.	$\pm \frac{1}{64}$	$\pm \frac{1}{32}$													
ISSUED	USED WITH	APPRO	DWN												
<p style="margin: 0; font-weight: bold; font-size: large;">Federal Telecommunication Laboratories, Inc.</p>		<p style="margin: 0; font-size: large;">RX-408812-1</p>													

CONFIDENTIAL

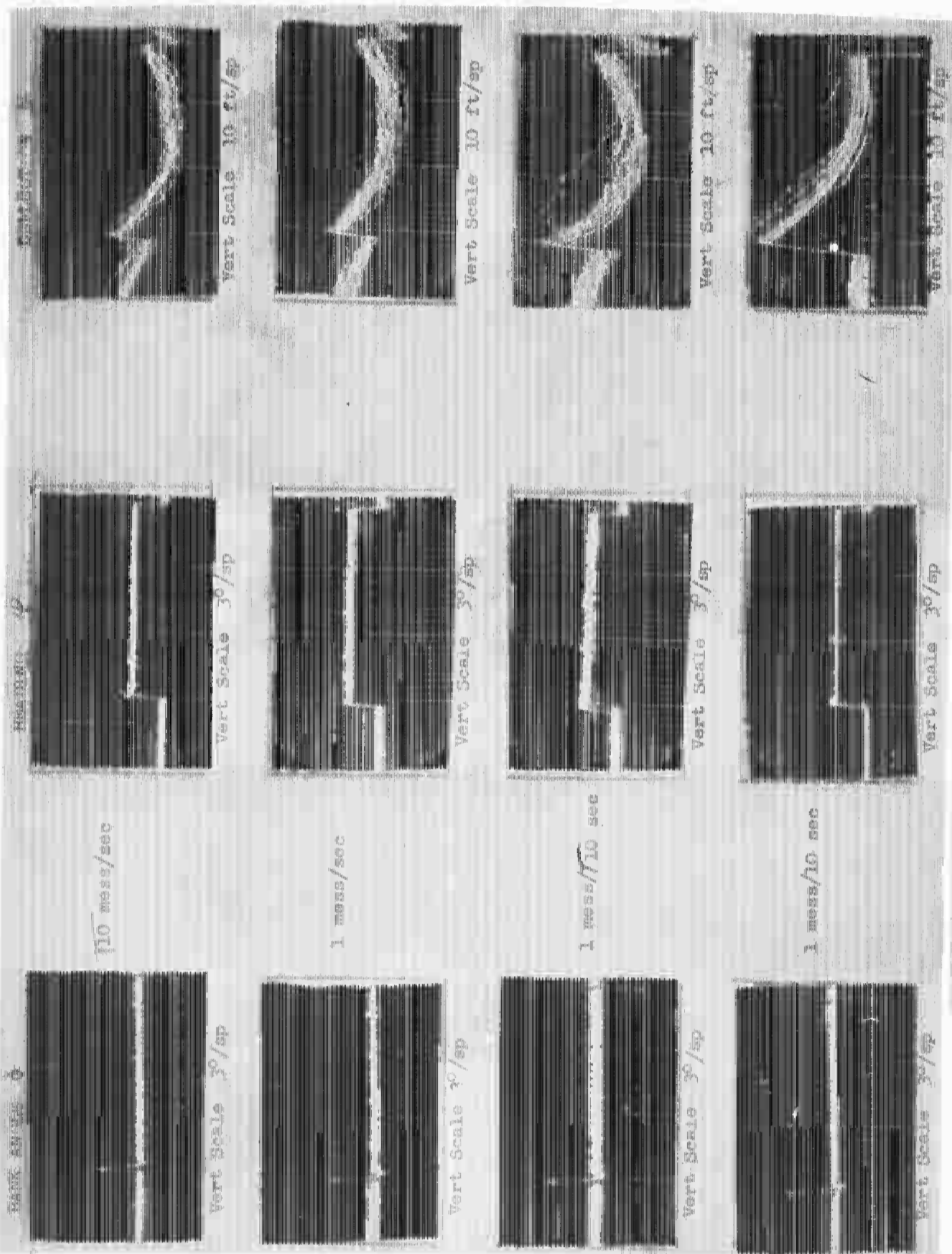

FIGURE 15 - AIRCRAFT RESPONSES TO HEADING ORDER OF 10, 20, 30, 40 MILES NOISE INJECTED, TIME SCALE: 2 MIN PER LARGE SQUARE

CONFIDENTIAL

CONFIDENTIAL

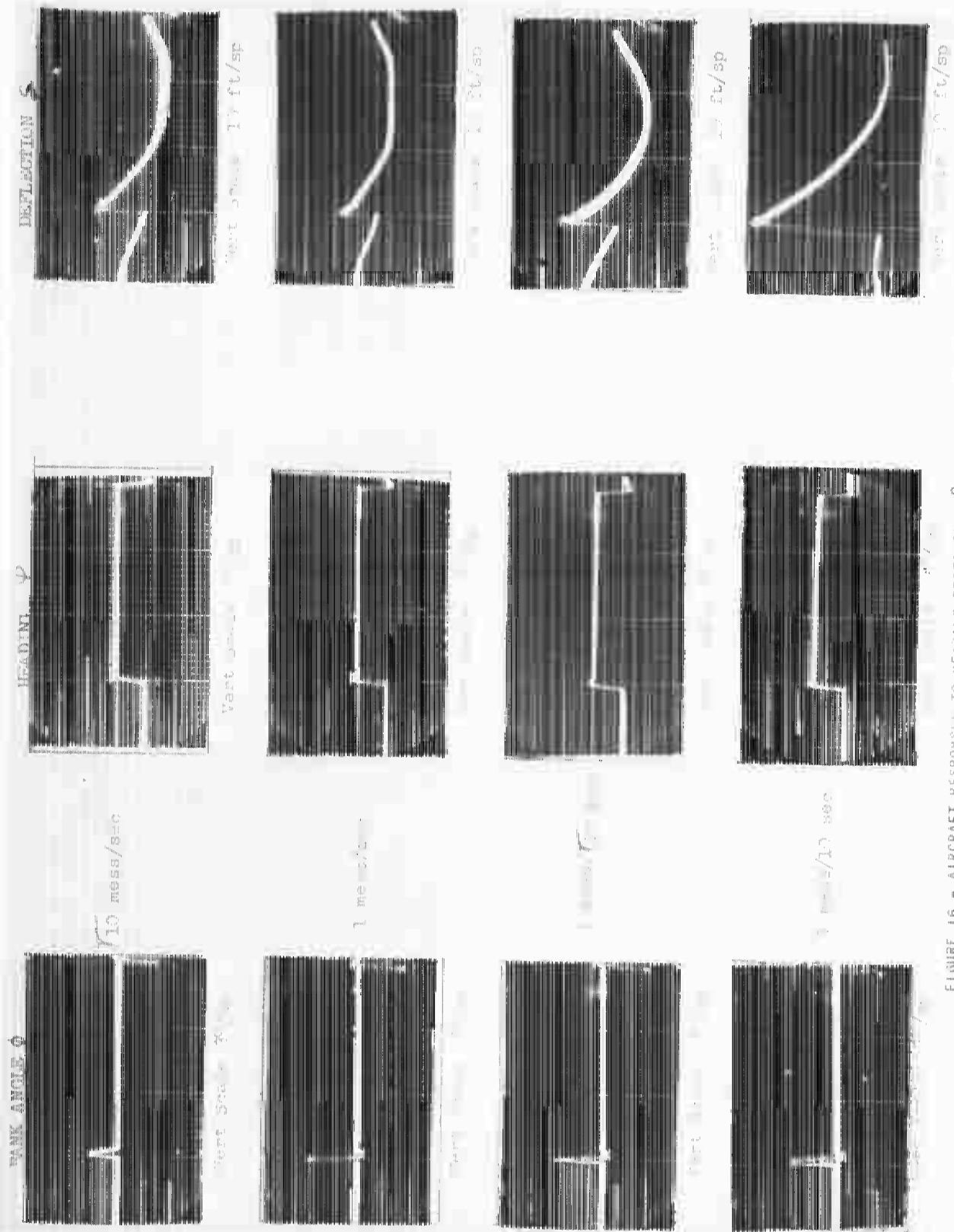

FIGURE 16 - AIRCRAFT RESPONSES TO HEADING ORDER OF 15°. SOFTENED K_s. NO NOISE.
TIME SCALE: 2 MIN PER LARGE SQUARE

CONFIDENTIAL

CONFIDENTIAL

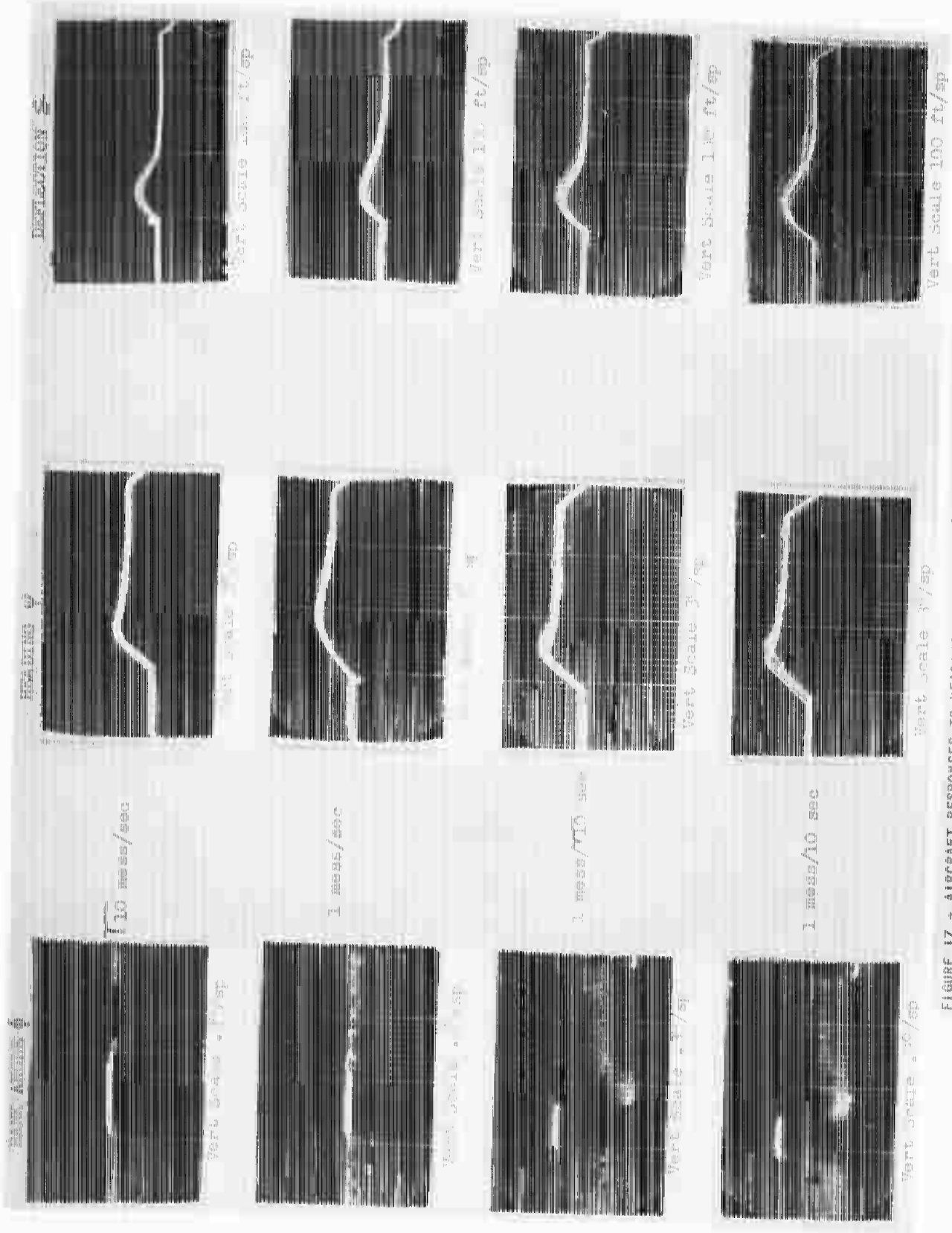

FIGURE 17 - AIRCRAFT RESPONSES TO HEADING ORDER OF 15°, LIMITED $\phi \pm 2^\circ$, 50 MI NCISE INJECTED, TIME SCALE: 2 MIN PER LARGE SQUARE

CONFIDENTIAL

CONFIDENTIAL

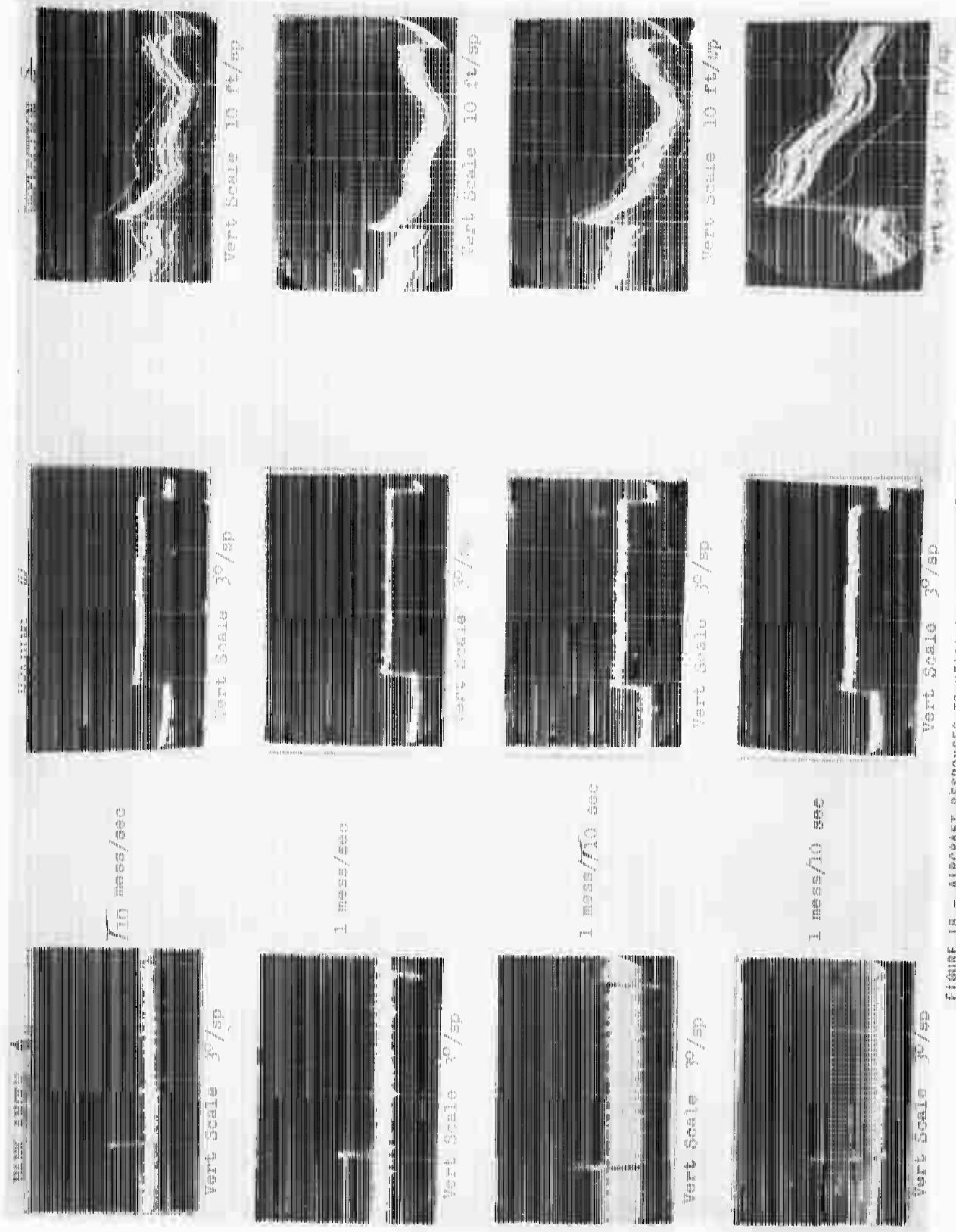

FIGURE 18 - AIRCRAFT RESPONSES TO HEADING ORDER OF 15°, SOFTENED K8, 200 MI NOISE
TIME SCALE: 2 MIN PER LARGE SQUARE

CONFIDENTIAL

CONFIDENTIAL

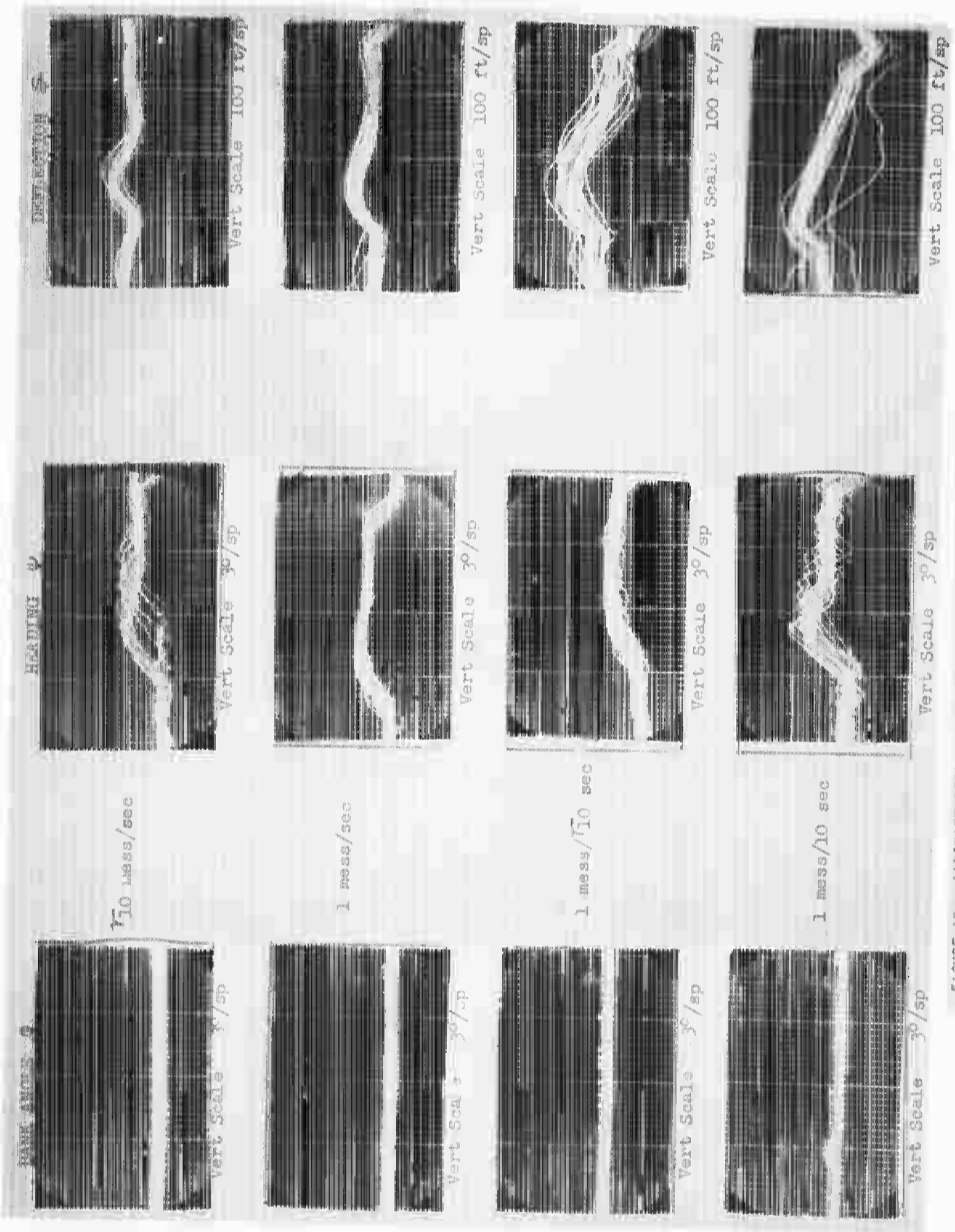

FIGURE 19 - AIRCRAFT RESPONSES TO HEADING ORDER OF 15°, LIMITED $\phi \pm 2^\circ$, 200 MI NOISE INJECTED, TIME SCALE: 2 MIN PER LARGE SQUARE

CONFIDENTIAL

CONFIDENTIAL

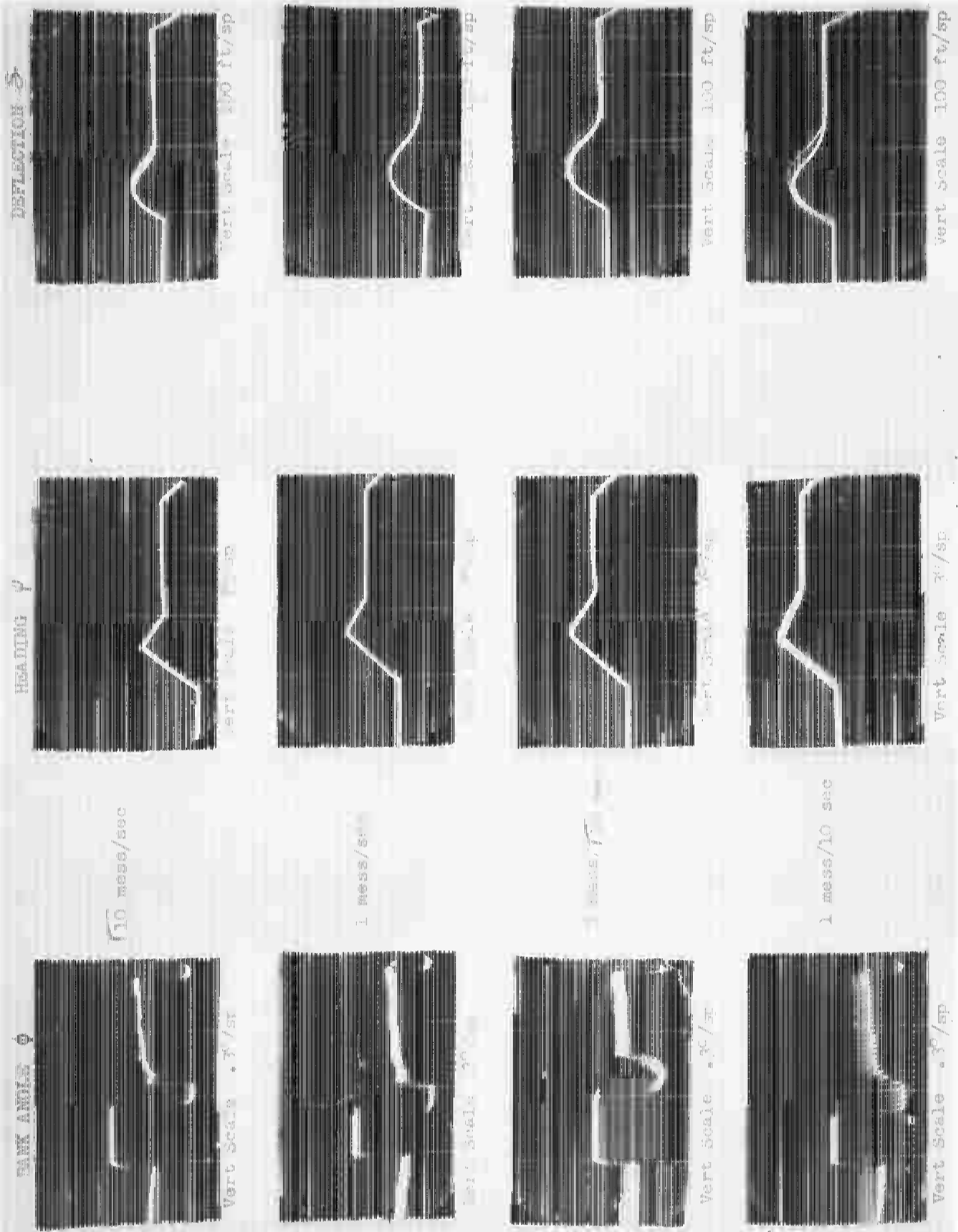

FIGURE 20 - AIRCRAFT RESPONSES TO HEADING ORDER OF 15°, LIMITED $\phi \pm 2^\circ$, 10 K CROSSWIND. NO NOISE, TIME SCALE: 2 MIN PER LARGE SQUARE

CONFIDENTIAL

CONFIDENTIAL

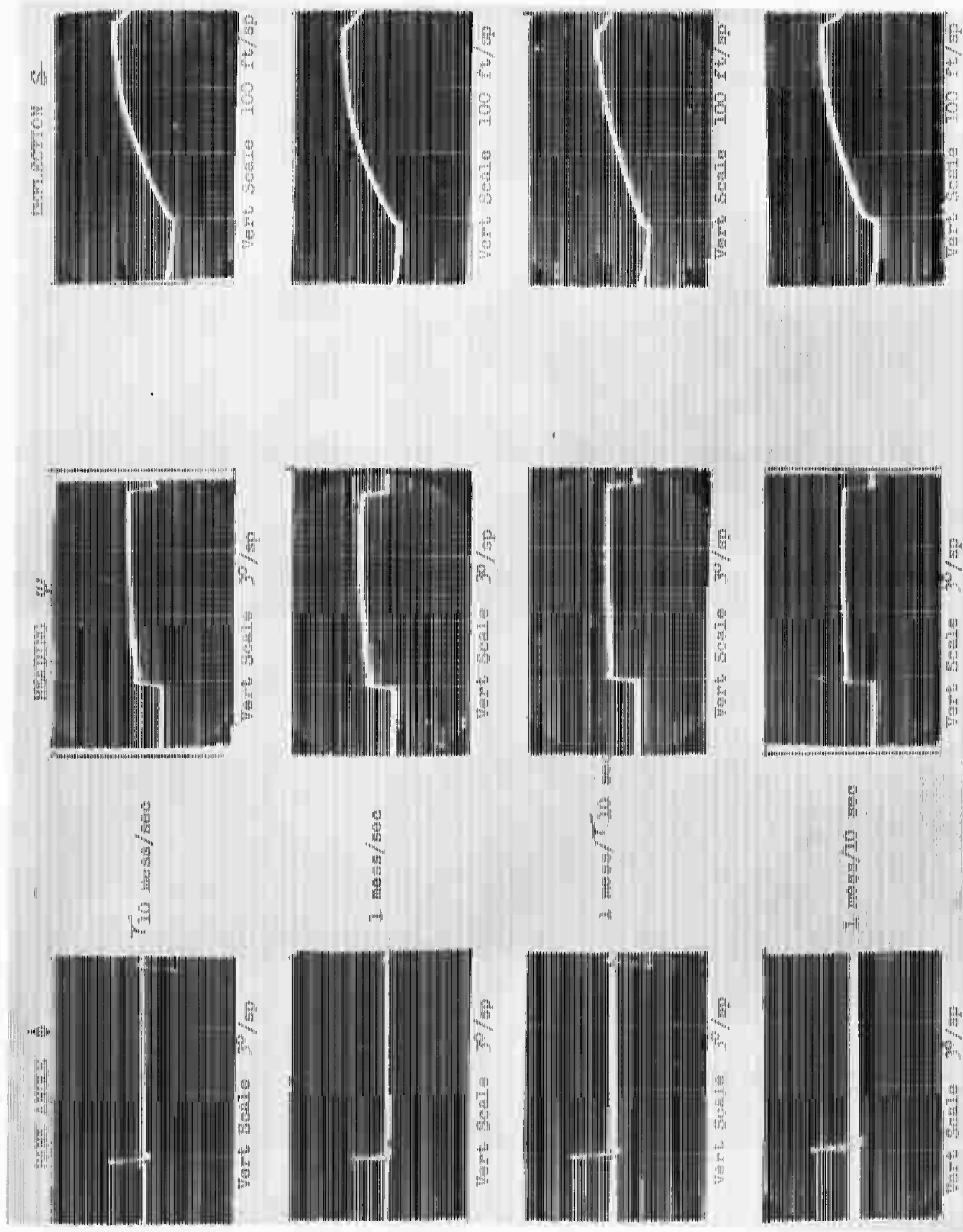

FIGURE 21 - AIRCRAFT RESPONSES TO HEADING ORDER OF 15° . SOFTENED K8, NO NOISE, 10 K CROSSWIND/ TIME SCALE: 2 MIN PER LARGE SQUARE

CONFIDENTIAL

Armed Services Technical Information Agency

Because of our limited supply, you are requested to return this copy WHEN IT HAS SERVED YOUR PURPOSE so that it may be made available to other requesters. Your cooperation will be appreciated.

AD

41982

NOTICE: WHEN GOVERNMENT OR OTHER DRAWINGS, SPECIFICATIONS OR OTHER DATA ARE USED FOR ANY PURPOSE OTHER THAN IN CONNECTION WITH A DEFINITELY RELATED GOVERNMENT PROCUREMENT OPERATION, THE U. S. GOVERNMENT THEREBY INCURS NO RESPONSIBILITY, NOR ANY OBLIGATION WHATSOEVER; AND THE FACT THAT THE GOVERNMENT MAY HAVE FORMULATED, FURNISHED, OR IN ANY WAY SUPPLIED THE SAID DRAWINGS, SPECIFICATIONS, OR OTHER DATA IS NOT TO BE REGARDED BY IMPLICATION OR OTHERWISE AS IN ANY MANNER LICENSING THE HOLDER OR ANY OTHER PERSON OR CORPORATION, OR CONVEYING ANY RIGHTS OR PERMISSION TO MANUFACTURE, USE OR SELL ANY PATENTED INVENTION THAT MAY IN ANY WAY BE RELATED THERETO.

Reproduced by
DOCUMENT SERVICE CENTER
KNOTT BUILDING, DAYTON, 2, OHIO

CONFIDENTIAL