

UNCLASSIFIED

AD NUMBER

AD043286

CLASSIFICATION CHANGES

TO: unclassified

FROM: confidential

LIMITATION CHANGES

TO:
Approved for public release; distribution is unlimited.

FROM:
Distribution authorized to DoD only;
Administrative/Operational Use; FEB 1954. Other requests shall be referred to Bureau of Ships (Navy), Washington, DC 20350.

AUTHORITY

BUSHIPS ltr dtd 1 Apr 1968; BUSHIPS ltr dtd 1 Apr 1968

THIS PAGE IS UNCLASSIFIED

Armed Services Technical Information Agency

Because of our limited supply, you are requested to return this copy WHEN IT HAS SERVED YOUR PURPOSE so that it may be made available to other requesters. Your cooperation will be appreciated.

AD

43286

NOTICE: WHEN GOVERNMENT OR OTHER DRAWINGS, SPECIFICATIONS OR OTHER DATA ARE USED FOR ANY PURPOSE OTHER THAN IN CONNECTION WITH A DEFINITELY RELATED GOVERNMENT PROCUREMENT OPERATION, THE U. S. GOVERNMENT THEREBY INCURS NO RESPONSIBILITY, NOR ANY OBLIGATION WHATSOEVER; AND THE FACT THAT THE GOVERNMENT MAY HAVE FORMULATED, FURNISHED, OR IN ANY WAY SUPPLIED THE SAID DRAWINGS, SPECIFICATIONS, OR OTHER DATA IS NOT TO BE REGARDED BY IMPLICATION OR OTHERWISE AS IN ANY MANNER LICENSING THE HOLDER OR ANY OTHER PERSON OR CORPORATION, OR CONVEYING ANY RIGHTS OR PERMISSION TO MANUFACTURE, USE OR SELL ANY PATENTED INVENTION THAT MAY IN ANY WAY BE RELATED THERETO.

Reproduced by
DOCUMENT SERVICE CENTER
KNOTT BUILDING, DAYTON, 2, OHIO

CONFIDENTIAL

**NOTICE: THIS DOCUMENT CONTAINS INFORMATION AFFECTING THE
NATIONAL DEFENSE OF THE UNITED STATES WITHIN THE MEANING
OF THE ESPIONAGE LAWS, TITLE 18, U.S.C., SECTIONS 793 and 794.
THE TRANSMISSION OR THE REVELATION OF ITS CONTENTS IN
ANY MANNER TO AN UNAUTHORIZED PERSON IS PROHIBITED BY LAW.**

NO. 43286
ASTIA FILE COPY

CONFIDENTIAL



SPERRY GYROSCOPE COMPANY
DIVISION OF THE SPERRY CORPORATION
GREAT NECK, NEW YORK

CONFIDENTIAL



CONFIDENTIAL

FURTHER DISSEMINATION IS AUTHORIZED ONLY TO
MILITARY PERSONNEL

FIRST INTERIM DEVELOPMENT REPORT
FOR
HIGH-POWER MULTIPLE ROTARY JOINT

4050572

THIS REPORT COVERS THE PERIOD 7 OCTOBER 1953 TO 7 JANUARY 1954

WARNING: This document contains information affecting the national defense of the United States within the meaning of the Espionage Laws, Title 18, U.S.C., Sections 793 and 794. The transmission or the revelation of its contents in any manner to an unauthorized person is prohibited by law. Reproduction of this document in any form by other than activities of the Department of Defense and the Atomic Energy Commission is not authorized unless specifically approved by the Secretary of the Navy or the Chief of Naval Operations.

SPERRY GYROSCOPE COMPANY
DIVISION OF THE SPERRY CORPORATION
GREAT NECK, NEW YORK

NAVY DEPARTMENT, BUREAU OF SHIPS, ELECTRONICS DIVISION
CONTRACT NO. N0bsr-63496, INDEX NO. 111616
SUBTASK 6

SPERRY REPORT
NO. 5224-1344-1

COPY NO.-----
FEBRUARY 1954
CONFIDENTIAL

54AA

56095

CONFIDENTIAL

ABSTRACT

This report describes the work performed in the first quarter of the program for the development of a light weight, high-power, multiple TransvarTM rotary joint.

In this quarter, the initial study and development of Transvar channels for a breadboard model were performed. Studies have also been made of corners, terminations, and transitions.

54 AA

56095

CONFIDENTIAL

TABLE OF CONTENTS

<u>Paragraph</u>		<u>Page</u>
	Abstract	1
	List of Illustrations	iv
PART I		
SECTION A - PURPOSE		
1	Purpose of Program	1
2	Breakdown into Working Phases	1
	a. Ereadboard Development Phase	1
	b. Manufacturing Phase	2
SECTION B - GENERAL FACTUAL DATA		
3	References	3
4	Formulae and Definitions	3
	a. Transvar Directional Coupler	3
	b. Transvar Rotary Joint	8
5	Measurement Procedures	10
	a. Introduction	10
	b. Low-Power Measurements	10
	c. High-Power Measurements	12

CONFIDENTIAL

TABLE OF CONTENTS (CONT)

SECTION C - DETAIL FACTUAL DATA

<u>Paragraph</u>		<u>Page</u>
6	Transvar Channels	14
7	Corners	16
8	Step Transition	17
9	Taper Transition	17
10	Terminations	17
11	Project Performance and Schedule	18

SECTION D - CONCLUSIONS

12	Conclusions	19
----	-------------	----

PART II

PROGRAM FOR NEXT INTERVAL

13	Program for Second Interim	20
----	----------------------------	----

CONFIDENTIAL

LIST OF ILLUSTRATIONS¹

Figure

- 1 Transvar Directional Coupler, Cutaway View
- 2 Propagating Modes in Transvar Coupler
- 3 Infinite, Parallel-Wire Grid
- 4 Rotary Joint, Cross Section
- 5 Rotary Joint, Schematic Representation
- 6 Low-Power Setup to Measure VSWR
- 7 Low-Power Setup to Measure Attenuation
- 8 High-Power Setup, Power Breakdown Detected with Viewing Bend
- 9 High-Power Setup, Power Breakdown Detected with Directional Coupler

¹Illustrations are grouped at the rear of the report.

CONFIDENTIAL

PART I
SECTION A

PURPOSE

1. PURPOSE OF PROGRAM

This program has as its purpose the design and construction of a multiple-channel, high-power, rotary joint of the Transvar type, operating from 5235 to 5325 mc. Primary objectives are: light weight, low VSWR, low insertion loss, and high power capacity. The original contract requires construction and delivery of a three-channel joint: two channels to carry 500 kw, the other 250 kw. The contract, however, is being renegotiated at the time of this writing, with the aim of changing the number of separate channels and their power requirements. Since renegotiations are incomplete, the work performed during this quarter was of a nature that applies to either the triple or double rotary joint.

2. BREAKDOWN INTO WORKING PHASES

a. Breadboard Development Phase

The scope of the project requires the construction of a breadboard model to ascertain several empirically

CONFIDENTIAL

determined parameters. The design objectives for this breadboard model are as follows:

- (1) Power-handling ability of channels greater than 250 and 500 kw at atmospheric pressure
- (2) VSWR of each channel less than 1.15
- (3) Insertion loss of each channel less than 0.5 db
- (4) Crosstalk between channels less than -30 db
- (5) Waveguide terminals equivalent to 2" x 1" waveguide
- (6) Speed of rotation to be 90 rpm
- (7) No axial loads carried by joint

b. Manufacturing Phase

Using information obtained from the breadboard model, a final model will be manufactured. This joint must satisfy all the forementioned requirements of the breadboard model, plus the following:

- (1) Minimized weight
- (2) Minimized axial length
- (3) Specification 16E4
- (4) Capability of maintaining a small positive pressure

CONFIDENTIAL

SECTION B
GENERAL FACTUAL DATA

3. REFERENCES

Macfarlane, G. G., "Surface Impedance of an Infinite Parallel-Wire Grid at Oblique Angles of Incidence," Journ. Inst. Elect. Eng., Vol. 93, No. 10, pp. 1523-1527, 1946.

Schelkunoff, S.A., Electromagnetic Waves, New York, D. Van Nostrand, 1943, p 254.

Tomiyasu, K. and S. B. Cohn, "The Transvar Directional Coupler," Proc. I.R.E., Vol. 41, pp. 922-926, July, 1953.

4. FORMULAE AND DEFINITIONS

a. Transvar Directional Coupler

The Transvar directional coupler in its usual form has a variable-length coupling element in the common narrow wall between two waveguides. The coupling element ordinarily consists of a number of closely spaced apertures formed by placing grid wires across the open portion of this common narrow wall. See figure 1. The sum of the two

CONFIDENTIAL

directive powers, P_1 and P_2 , is equal to the input power, P_0 . By suitable design of the coupling region, P_1 can be made zero and P_2 equal to P_0 .

The theory of operation, which has been derived previously¹, is best described by considering the two major propagating modes in the coupling region. Figure 2 illustrates these modes. However, note that figure 2, while it shows the relationship occurring when a maximum of power is in guide I, is primarily intended to illustrate the symmetry and antisymmetry of the two modes.

Let λ_{g1} be the guide wavelength of the symmetrical mode, and λ_{g2} that of the antisymmetrical mode. Since the TE_{10} mode exists in the individual guide (or TE_{20} mode in the composite guide), λ_{g2} is known for any given waveguide size. Because this mode has zero electric field in the plane of the coupling structure, its phase velocity will be unaffected by the structure, and λ_{g2} will remain constant. The symmetrical mode (TE_{10} in composite guide) on the other hand, will be inductively loaded and its phase velocity will be altered, since its electric field is a maximum in the coupling region.

- - - - -
¹K. Tomiyasu and S.B. Cohn, "The Transvar Directional Coupler," Proc. I.R.E., Vol. 41, pp. 922-926, July, 1953.

CONFIDENTIAL

Because the guide wavelengths of the two modes are not the same, when the modes are superimposed, the result is (1) an electric-field maximum at the time the modes are in phase addition and (2) a minimum at the time of phase opposition. The phase reversal can be expressed as follows:

$$\pi = \left[\frac{2\pi d}{\lambda_{g1}} \right] - \left[\frac{2\pi d}{\lambda_{g2}} \right] \quad (1)$$

where

d = distance between the electric-field maximum
and an adjacent minimum in one guide

This equation can be rewritten:

$$d = \frac{1}{2 \left[\frac{1}{\lambda_{g1}} - \frac{1}{\lambda_{g2}} \right]} \quad (2)$$

If the length of the coupling region is made equal to d, then full power transfer from one guide to the other will be realized, since the two modes are approximately equal in amplitude. Full transfer will also be obtained for lengths of 3d, 5d, 7d, and so forth.

The determination of λ_{g1} for use in equation (2) is made on the basis of an infinite, parallel-wire grid as shown in figure 3. This structure is equivalent to the coupling region of the coupler by the reasoning that follows.

CONFIDENTIAL

If two plane waves, E_1 and E_2 (equal in amplitude and phase) impinge upon the grid at equal angles (figure 3a), the incident, transmitted, and reflected waves will result in electric-field minima in planes parallel to the grid and equidistant from it (figure 3b). The location of these planes is dependent upon the angle of incidence of the waves. Since the electric field is zero, or very nearly so, it is possible to insert two perfectly conducting surfaces in these planes without affecting the fields. Furthermore, since the geometry is uniform in the direction of the grid wires, it is possible to add two conducting walls perpendicular to the wires. The enclosure formed by these four walls is in every way identical to the directional coupler. In the actual coupler, the boundary conditions require zero electric field at a specified distance from the grid. This establishes the angle of incidence, θ , from which the wavelength of the symmetrical mode can be determined.

$$\lambda_{g1} = \frac{\lambda_0}{\sin \theta} \quad (3)$$

where

λ_0 = the free-space wavelength

The following equations, (4) and (5), are used to determine θ for use in equation (3):

CONFIDENTIAL

$$\cos \theta = \frac{F\lambda_0}{2\pi a} \quad (4)$$

The value of p is determined from the following relationship:

$$\frac{\tan p}{p} = \left[-\frac{a}{\pi r} \right] \left[\sqrt{1 - \left[\frac{\lambda'}{2\pi r} \right]^2} \right] + F \left[a, \frac{\lambda'}{\lambda_0} \right] \quad (5)$$

where

a = distance from the grid to the plane of E-field minimum; or, wide dimension of one coupler guide

λ' = grid-wire spacing

r = grid-wire radius

$F \left[a, \frac{\lambda'}{\lambda_0} \right]$ = correction term given graphically by Macfarlane¹

Equations (4) and (5) result from an analysis of the reactance presented by the parallel-wire grids, and are

¹G.G. Macfarlane, "Surface Impedance of an Infinite Parallel-Wire Grid at Oblique Angles of Incidence," Journ. Inst. Elect. Eng., Vol. 93, No. 10, pp. 1523-1527, 1946.

CONFIDENTIAL

derived by Tomiyasu and Cohn¹ using techniques outlined by Schelkunoff² and Macfarlane³.

b. Transvar Rotary Joint

The distinguishing feature of the rotary joint is the two cascaded Transvar couplers formed in a circle. In the joint to be developed, the waveguides are formed in an E-plane circle with a common narrow wall. In this narrow wall is the coupling structure, usually of the inductive type. Figure 4 shows a cross section of a two-channel joint. Figure 5 is the schematic representation of each channel. Full power transfer for all angles of rotation is maintained because the sum of the open lengths of each coupler is never less than the length required. In figures 5a and 5c, full power transfer is realized because, in each case, there is one open coupler of the correct length as determined from equation (2). In figure 5b, the sum of the two open portions is equal to the correct length, and that power which does not pass through coupler B will pass through coupler A. In the case represented by figure 5e, all the power passes through the first coupler and never reaches the partially open second coupler.

¹Tomiyasu and Cohn, "Transvar Directional Coupler".

²S.A. Schelkunoff, Electromagnetic Waves, New York, D. Van Nostrand, 1953, p 254.

³Macfarlane, "Surface Impedance."

CONFIDENTIAL

The condition shown by figure 5d is of special interest and will be referred to as the diagonal-arm condition. When the joint is in this position, pseudo resonances occur for certain frequencies. These resonances occur because the wave in the secondary or output arm, impinging upon partially open coupler A, is in such a phase that it adds to the incident wave in the input arm, resulting in an apparent increase in power. Theoretically, these resonances can be avoided by making the mean circumference of the channel such that the returning wave is 90 degrees out of phase with the incident wave. This is expressed mathematically as

$$C_m = \left(n + \frac{1}{4} \right) \lambda_{gs} \quad (6)$$

where

C_m = mean circumference of the Transvar channel
n = any integer

Using data on existing joints, equation (6) has been reduced to the following empirical form:

$$C_m = \left(n + \frac{2}{8} \right) \lambda_{gs} \quad (7)$$

5. MEASUREMENT PROCEDURES

a. Introduction

The measurement procedures to be used in the determination of the various electrical characteristics have not been fully determined. Most measurements (such as VSWR and insertion loss) will be made at low power levels; however, a high-power setup will be used to study the unit under actual operating conditions. In the development of the joint, it is necessary to design a number of individual components, and these will also be tested under low- and high-power conditions. Design will be based on low-power information; performance will be evaluated under high-power tests.

b. Low-Power Measurements

The low-power setup used for the determination of VSWR is a conventionally arranged standing-wave detector (figure 6). The klystron signal source, which is modulated at an audio rate, feeds microwave energy to the test piece through a suitable attenuator and frequency meter. An impedance transformer is used to match the klystron to the line. Since a matched load is placed after the test piece, all reflections will originate in the piece itself. The probe

CONFIDENTIAL

in the standing-wave detector monitors the electric field and a tuned audio amplifier is used to detect the rectified output of the probe.

Measurements of insertion loss and attenuation will probably be made using accepted i-f substitution techniques. The setup used for these measurements is shown in figure 7. The basis for this technique is the calibrated attenuator which is incorporated as part of the Sperry Microline^(R) Microwave Receiver Model 296. The calibration of the attenuator is known accurately at the receiver frequency of 30 mc. It is necessary to mix the microwave signal with that of a local oscillator in order to obtain an intermediate frequency of 30 mc--hence, the klystron local oscillator. The pre-amplifier and the receiver are tuned to this 30-mc frequency, and a meter incorporated in the receiver indicates the power level. When the signals from the source and from the local oscillator have been set to their required frequencies, the i-f level indicated on the VTVM is set to some convenient point by means of the calibrated attenuator. The unknown loss is then added (or subtracted) and the calibrated attenuator readjusted to return the i-f level to its original value. The difference in the attenuator readings, before and after the test piece was changed, represents the loss.

c. High-Power Measurements

The approach to high-power testing can take any one of a number of courses. These courses are basically the same, in that they involve refinements almost entirely in the measurement of power. Necessary in each is a high-power source (power supply, modulator, and magnetron), some means of varying power to the test piece, and a dummy load to dissipate power transmitted through the test piece.

Two such approaches would be: (1) incident power can be completely monitored by locating a calibrated directional coupler and detecting equipment before the test piece, or (2) pulse shape and frequency can be monitored in the fore-mentioned manner, with power being measured beyond the piece calorimetrically or with another calibrated coupler. Further variations are encountered in the detection of breakdown. A directional coupler can be used to monitor the reflected power which, at breakdown, should show a marked increase. Breakdown can also be detected by audible or visual means. Figures 8 and 9 illustrate some of these setups in block-diagram form.

The final setup utilized for high-power testing will depend upon a consideration of accuracies required,

CONFIDENTIAL

applicability of equipment to the test unit, and availability of component parts. Some components that may be required are various bends, and transitions from 2" x 1" to 1-1/2" x 3/4" waveguides.

CONFIDENTIAL

SECTION C

DETAIL FACTUAL DATA

6. TRANSVAR CHANNELS

It has been shown in equations (2), (3), and (7) that the diameter of the channels in the joint is dependent upon the waveguide size and the coupling configuration. The channel diameters are further restricted by such physical limitations as torque-tube diameter, bearings, noninterference of channels, and imposed maximum diameter. One approach to the development of a channel consists of the following steps: First, from equation (7) determine usable diameters for the guide size in question. Second, from equation (2) find the wavelength of the symmetrical mode necessary for these diameters. Third, knowing this wavelength, solve for the coupling structure. This technique was adopted because it allows the guide size to be predetermined, a factor which aids the manufacture of a multiple-channel joint.

In the initial study of the waveguide channels for this unit, the use of 1.372" x 0.622" I.D. waveguide was assumed throughout. This waveguide was chosen because it is the standard size (1-1/2" x 3/4" O.D.) which would make λ_{g2} long at the design frequency of 5280 mc, thereby reducing the circumferential length of coupler required.

CONFIDENTIAL

Refer to equation (2). Later, it was requested that the waveguide terminals be made equivalent to 1.872" x 0.872" I.D. waveguide (2" x 1" O.D.). Calculating the usable diameters for both these guides from equation (7) gives the following results:

n	MEAN DIAMETERS (inches)	
	1.372" x 0.622" I.D. WAVEGUIDE	1.872" x 0.872" I.D. WAVEGUIDE
8	10.276	-
9	11.503	-
10	12.730	-
11	13.957	10.111
12	15.184	10.978
13	16.411	11.865
14	17.638	12.752
15	18.865	13.639
16	20.092	14.526
17	-	15.413
18	-	16.300
19	-	17.188
20	-	18.075
21	-	18.962
22	-	19.849
23	-	20.736

CONFIDENTIAL

In order to obtain the values of d in equation (2) which would satisfy the usable diameters for 1.872" x 0.872" waveguide shown in the preceding table, the configuration of the coupling structure becomes impractical. For this reason, it was decided to use 1.372" x 0.622" waveguide in the coupler portions of the joint, with a quarter-wave-step or a taper transition to the 1.872" x 0.872" external waveguide. Final dimensions for the channels will be selected from the preceding table.

7. CORNERS

Because the Transvar joint will have adjacent concentric channels, it is not feasible to bring the terminals out through E-plane bends, as has been done in the past with some joints. Instead, it becomes necessary to include H-plane transitions, preferably, 90-degree corners which would minimize space requirements. During this interim, such corners were developed for 1.372" x 0.622" I.D. waveguide of both the mitered and post-tuned type. Results are shown in the following table:

CORNER	VSWR		
	at 5235 mc	at 5280 mc	at 5325 mc
Post-Tuned	1.030	1.025	1.035
Mitered	1.025	1.015	1.020

CONFIDENTIAL

8. STEP TRANSITION

A low-VSWR, quarter-wave-step transition is being developed for possible use between the 1.372" x 0.622" I.D. internal waveguide and the 1.872" x 0.872" I.D. external waveguide. Difficulties in the design of this transition may arise because of the wavelength involved, but further study of the problem is expected to yield a satisfactory result.

9. TAPER TRANSITION

Since a quarter-wave-step transition may be unable to carry the required power, the feasibility of using tapers is being considered. Preliminary investigation indicates that these tapers may be 1.750" long, which would increase slightly the over-all axial length of the joint.

10. TERMINATIONS

A preliminary study of medium-power terminations is being made. Because of space limitations, it has been decided to use the quarter-wave-step type. Power requirements warrant the consideration of polyiron and silicon carbide as dissipative materials.

CONFIDENTIAL

11. PROJECT PERFORMANCE AND SCHEDULE

A project performance and schedule chart will be added to later reports when the renegotiation and clarification of the present contract are concluded.

CONFIDENTIAL

SECTION D
CONCLUSIONS

12. CONCLUSIONS

During the first quarter, some initial development work for the Transvar channels in the rotary joint was performed. The theory has been reduced to a table which will permit rapid choice of channel dimensions when the number of required channels is known.

Design of 90-degree H-plane corners for use in the rotary joint has been made. In addition, preliminary study has been made of waveguide transitions and terminations.

CONFIDENTIAL

PART II
PROGRAM FOR NEXT INTERVAL

13. PROGRAM FOR THE SECOND INTERIM

Pending completion of contact revisions, during the next quarter it is planned to complete the design and begin fabrication of the breadboard model. It is also proposed to complete the design of the corners, transitions, and terminations; and subject them to appropriate high-power tests. This will determine their ultimate suitability for use in the joint. For this reason, it will be necessary to activate high-power testing facilities during the quarter.

Mechanical design of the final model will also be studied during the next interim. Prime consideration will be given to oil seals and bearings.



CONFIDENTIAL

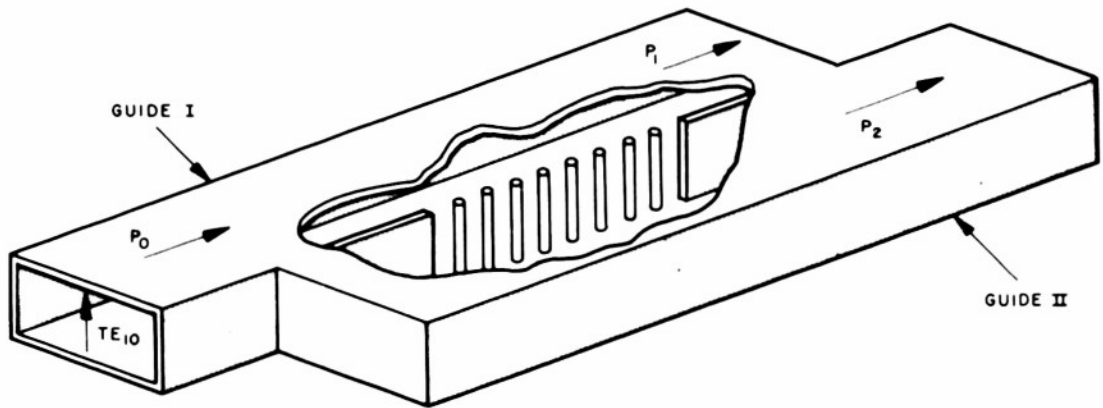
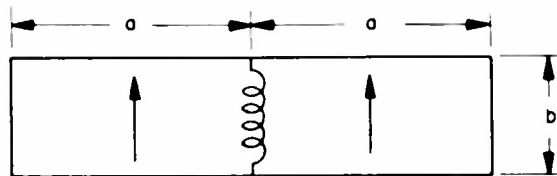

FIGURE 1
TRANSVAR DIRECTIONAL COUPLER,
CUTAWAY VIEW



GUIDE I GUIDE II

SYMMETRICAL MODE

ARROWS INDICATE DIRECTION
OF E-FIELD VECTORS

SCHEMATIC REPRESENTATION OF
INDUCTIVE COUPLING STRUCTURE

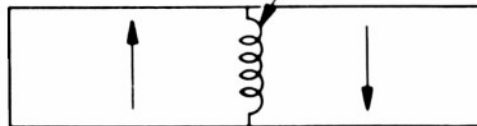

GUIDE I GUIDE II

ANTISYMMETRICAL MODE

FIGURE 2
PROPAGATING MODES IN TRANSVAR COUPLER

CONFIDENTIAL



CONFIDENTIAL

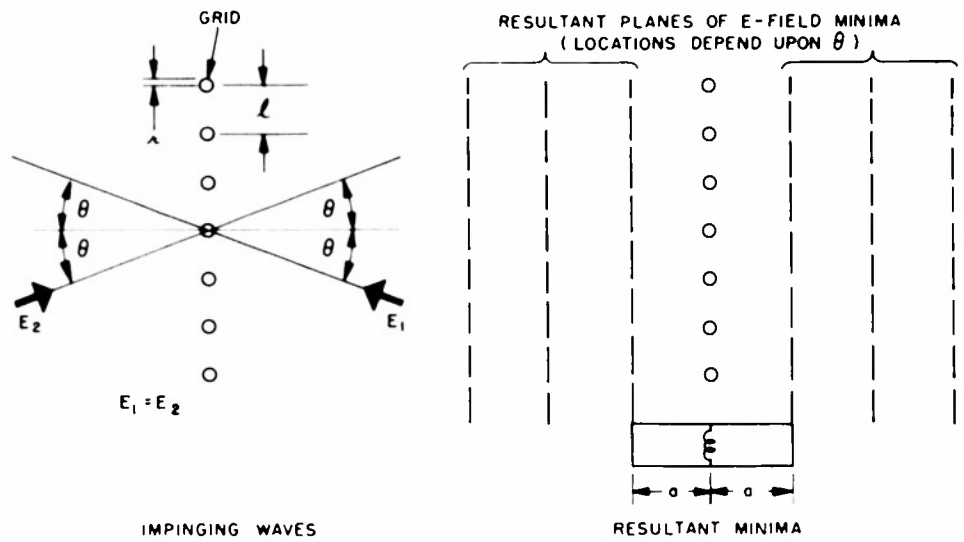

FIGURE 3
INFINITE, PARALLEL-WIRE GRID

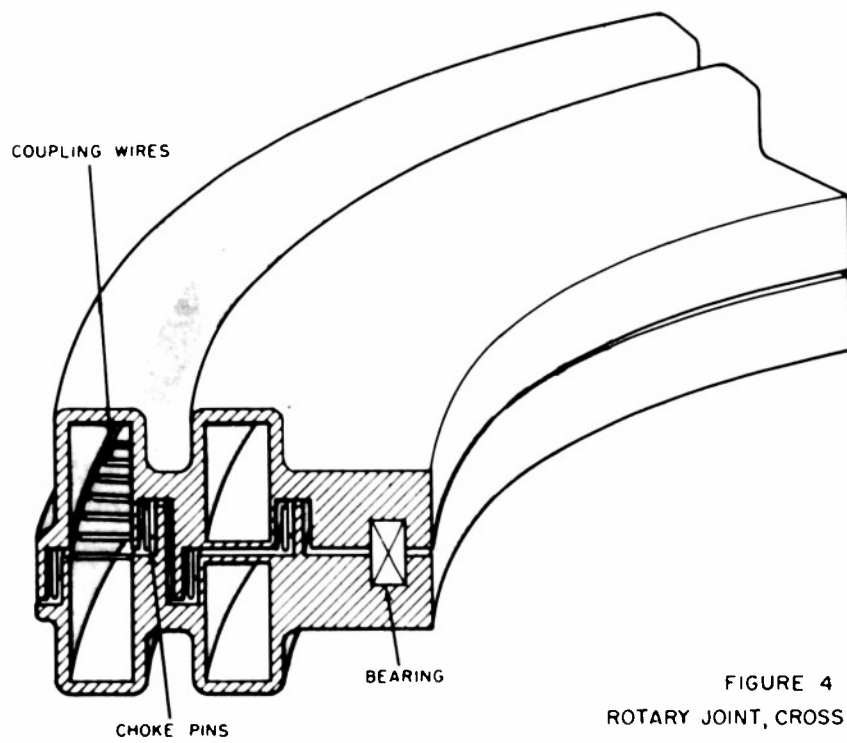

FIGURE 4
ROTARY JOINT, CROSS SECTION

CONFIDENTIAL



CONFIDENTIAL

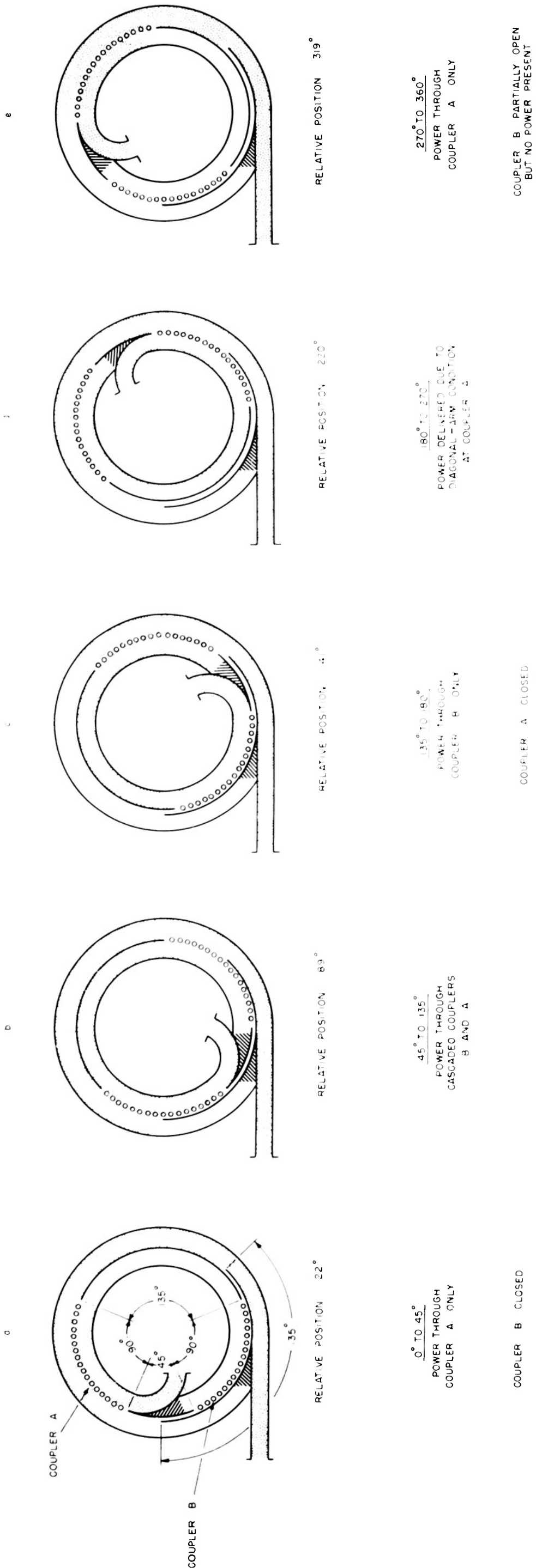

FIGURE 5
 ROTARY JOINT,
 SCHEMATIC REPRESENTATION
 CONFIDENTIAL



CONFIDENTIAL

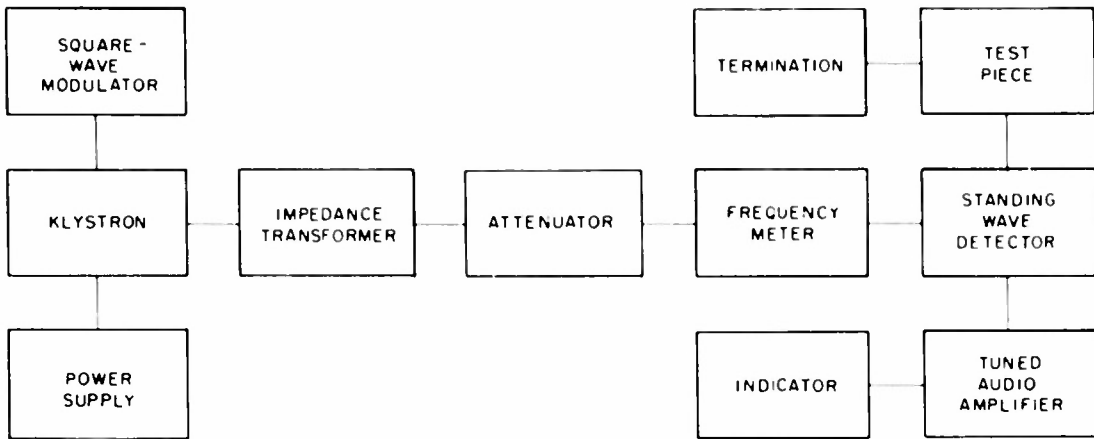

FIGURE 6
LOW-POWER SETUP TO MEASURE VSWR

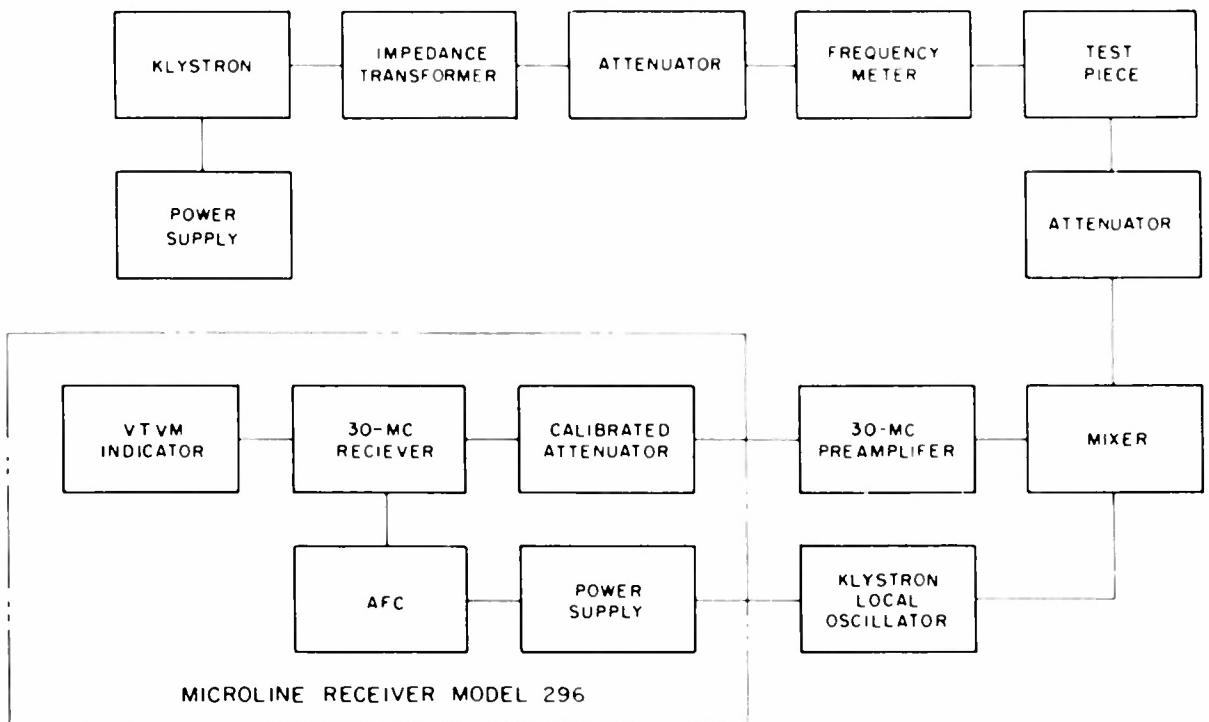

FIGURE 7
LOW-POWER SETUP TO MEASURE
ATTENUATION AND INSERTION LOSS

CONFIDENTIAL

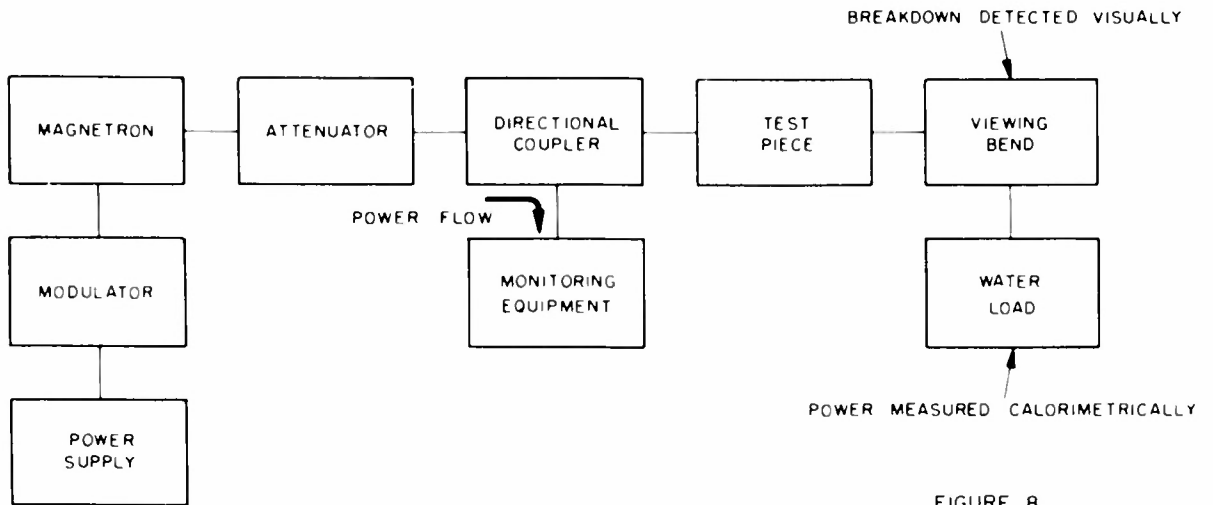

FIGURE 8
HIGH-POWER SETUP, POWER BREAKDOWN
DETECTED WITH VIEWING BEND

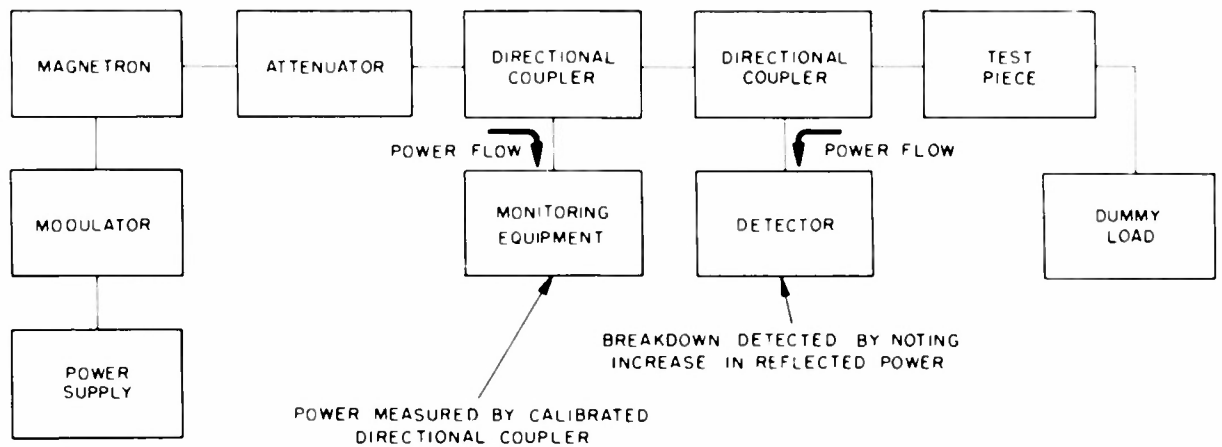

FIGURE 9
HIGH-POWER SETUP, POWER BREAKDOWN
DETECTED WITH DIRECTIONAL COUPLER

Armed Services Technical Information Agency

Because of our limited supply, you are requested to return this copy **WHEN IT HAS SERVED YOUR PURPOSE** so that it may be made available to other requesters. Your cooperation will be appreciated.

AD

43286

NOTICE: WHEN GOVERNMENT OR OTHER DRAWINGS, SPECIFICATIONS OR OTHER DATA ARE USED FOR ANY PURPOSE OTHER THAN IN CONNECTION WITH A DEFINITELY RELATED GOVERNMENT PROCUREMENT OPERATION, THE U. S. GOVERNMENT THEREBY INCURS NO RESPONSIBILITY, NOR ANY OBLIGATION WHATSOEVER; AND THE FACT THAT THE GOVERNMENT MAY HAVE FORMULATED, FURNISHED, OR IN ANY WAY SUPPLIED THE SAID DRAWINGS, SPECIFICATIONS, OR OTHER DATA IS NOT TO BE REGARDED BY IMPLICATION OR OTHERWISE AS IN ANY MANNER LICENSING THE HOLDER OR ANY OTHER PERSON OR CORPORATION, OR CONVEYING ANY RIGHTS OR PERMISSION TO MANUFACTURE, USE OR SELL ANY PATENTED INVENTION THAT MAY IN ANY WAY BE RELATED THERETO.

Reproduced by
DOCUMENT SERVICE CENTER
KNOTT BUILDING, DAYTON, 2, OHIO

CONFIDENTIAL