

UNCLASSIFIED

AD NUMBER
AD045680
NEW LIMITATION CHANGE
TO Approved for public release, distribution unlimited
FROM Distribution authorized to U.S. Gov't. agencies and their contractors; Administrative/Operational Use; Aug 1954. Other requests shall be referred to Office of Naval Research, Arlington, VA.
AUTHORITY
ONR ltr, 26 Oct 1977

THIS PAGE IS UNCLASSIFIED

THIS REPORT HAS BEEN DELIMITED  
AND CLEARED FOR PUBLIC RELEASE  
UNDER DOD DIRECTIVE 5200.20 AND  
NO RESTRICTIONS ARE IMPOSED UPON  
ITS USE AND DISCLOSURE.

DISTRIBUTION STATEMENT A

APPROVED FOR PUBLIC RELEASE;  
DISTRIBUTION UNLIMITED.

# Armed Services Technical Information Agency

Because of our limited supply, you are requested to return this copy WHEN IT HAS SERVED YOUR PURPOSE so that it may be made available to other requesters. Your cooperation will be appreciated.

# AD

# 45680

**NOTICE: WHEN GOVERNMENT OR OTHER DRAWINGS, SPECIFICATIONS OR OTHER DATA ARE USED FOR ANY PURPOSE OTHER THAN IN CONNECTION WITH A DEFINITELY RELATED GOVERNMENT PROCUREMENT OPERATION, THE U. S. GOVERNMENT THEREBY INCURS NO RESPONSIBILITY, NOR ANY OBLIGATION WHATSOEVER; AND THE FACT THAT THE GOVERNMENT MAY HAVE FORMULATED, FURNISHED, OR IN ANY WAY SUPPLIED THE SAID DRAWINGS, SPECIFICATIONS, OR OTHER DATA IS NOT TO BE REGARDED BY IMPLICATION OR OTHERWISE AS IN ANY MANNER LICENSING THE HOLDER OR ANY OTHER PERSON OR CORPORATION, OR CONVEYING ANY RIGHTS OR PERMISSION TO MANUFACTURE, USE OR SELL ANY PATENTED INVENTION THAT MAY IN ANY WAY BE RELATED THERETO.**

Reproduced by *Best Available Copy*  
**DOCUMENT SERVICE CENTER**  
KNOTT BUILDING, DAYTON, 2, OHIO

# UNCLASSIFIED

AD No. 45680

ASTIA FILE COPY

**THE ROTATING ARM RESOLVING ANEMOMETER**

Office of Naval Research  
Contract N7 onr-48705

Navy Department  
Project NR 082-111

Technical Report No. 2

A. & M. Project 59 — Reference 54-56T

Arnold H. Glaser

August 1954

Research Conducted through the  
*Texas A.&M. Research Foundation*  
COLLEGE STATION, TEXAS

THE AGRICULTURAL AND MECHANICAL COLLEGE OF TEXAS  
Department of Oceanography  
College Station, Texas

Research conducted through the  
Texas A & M Research Foundation

Technical Report No. 2

A&M Project 59 Reference 54-56T

THE ROTATING ARM RESOLVING ANEMOMETER

by

Arnold H. Glaser

August 1954

The research reported in this document has been made possible through support and sponsorship extended by the Office of Naval Research under Contract N7onr-48705, NR No. 082-111. It is published for technical information only, and does not necessarily represent recommendations or conclusions of the sponsoring agency.

John C. Freeman, Jr., Project Supervisor

THE AGRICULTURAL AND MECHANICAL COLLEGE OF TEXAS  
Department of Oceanography  
College Station, Texas

Research conducted through the  
Texas A & M Research Foundation

Technical Report No. 2

A&M Project 59 Reference 54-56T

THE ROTATING ARM RESOLVING ANEMOMETER

by

Arnold H. Glaser

August 1954

The research reported in this document has been made possible through support and sponsorship extended by the Office of Naval Research under Contract N7onr-48705, NR No. 082-111. It is published for technical information only, and does not necessarily represent recommendations or conclusions of the sponsoring agency.

John C. Freeman, Jr., Project Supervisor

## CONTENTS

	<u>Page</u>
I. Introduction	1
II. Principle of Operation	3
A. Some Aerodynamic Properties of the Cylinder	3
B. The Rotating Arm	4
C. Obtaining the Wind Velocity	5
D. The Shearing Stress	6
E. Effect of Cross Wind	7
F. Conclusion	8
III. Mechanical Features	9
IV. Electronic Circuitry	10
V. Performance	13
A. General	13
B. Light Winds	13
C. Comparison with Other Instruments	14
VI. Proposed Future Development	14
A. Fluxmeter	14
B. Counter Rotating Arms System	14
VII. Concluding Remarks	15

## I. Introduction

An instrument that can resolve the instantaneous motion at a point into components, or equivalently, indicate the vector direction and magnitude of the instantaneous wind is of great utility in the study of the details of the structure of turbulent motion in the atmosphere and ocean. Time constants should be sufficiently short to permit the resolution of at least the significant range of turbulent eddies (Inoue 1954).

Instruments of this type have their greatest utility, apart from estimates of the statistical properties of the turbulent velocity field, in studies of the vertical flux of heat, moisture, or momentum. These are obtained through the relation

$$F = \overline{\rho w \phi}$$

where  $F$  is the vertical flux of the intensive property  $\phi$ ,  $w$  is the instantaneous vertical component of the wind velocity, and the bar indicates averaging over a period of time sufficiently great to assure representation of significant eddy sizes (Swinbank, 1951; MacCready, 1953b).

Two types of instrument have previously emerged that at least partially satisfy the requirements of rapid response and vector resolution. One is based on the use of the bi-directional vane (Mazzarella, 1952; Gill, 1954b) to determine the direction of the flow and a fast response anemometer of some type (Parson and Bunker, 1952; Gill, 1954a). Velocity components are obtained by appropriate trigonometric calculations. This type of instrument tends to be hampered by the rather complex response of the bivane system.

The other type in use makes use of geometric combinations of hot wire type instruments to determine both direction and velocity. (Shiotani, 1950; Swinbank, 1951; MacCready, 1953a). This type has the advantage of excellent speed of response, but it is somewhat difficult to make the indications of the instrument independent of atmospheric temperature.

Nearly all of these systems suffer from the basic non-linearity of the indicating system. Calculation of the flux of a property from equation (1) calls for the recording of the various instrument outputs, reading from the charts at very close intervals of time, conversion of the non-linear indication to the actual value, performing the trigonometric resolution, and finally the multiplication and integration indicated. If one is seeking the contribution of eddies of 0.1 second passage time, this process must be repeated each 0.05 second. Evaluation of even a 5-minute run becomes a sizeable task.

The extreme amount of calculation required makes it desirable to use some form of automatic calculation, either analog or digital, to permit somewhat more extended observations. Digital calculation can cope with the non-linearity of rapid response instruments, but the problem of sufficiently rapid digitizing of all the quantities has not yet been met by simple means. Analog computers offer more promise of satisfactory performance without undue complication. Various analog methods have been adopted to linearize the indication of hot-wire instruments. Parson and Bunker (1952) used a servo-operated cam system, while MacCready used a somewhat complex electronic system. Neither system gave the flux without further computation.

The original concept of the instrument to be described arose during a discussion with Professor V. E. Suomi of the University of Wisconsin while the author was employed on an Air Force Cambridge Research Center

project under Professor Suomi. Detailed development of the principles and design of the instrument and computers was done by the present project.

This anemometer system was designed to operate directly with an analog computer to give integrated values of the vertical flux of heat, moisture, and momentum. It is intended for continuous operation, with average values of the fluxes presented periodically, although instantaneous values of any of the measured quantities are readily available. The anemometer offers linearity and ruggedness in return for some increase in complication and some anomalies of function that will be described later.

## II. Principle of Operation

### A. Some aerodynamic properties of the cylinder

Let us examine some of the aerodynamic properties of the circular cylinder. If a cylinder be placed in a flow with its axis perpendicular to the direction of flow, it can be shown (Milne - Thompson, 1950, p. 152) that the pressure distribution about the cylinder for the case of non-viscous irrotational flow is

$$p - \pi = \frac{1}{2} \rho U^2 (1 - 4 \sin^2 \theta) \quad (2)$$

where  $p$  is the pressure at the surface of the cylinder,  $\pi$  is the static pressure,  $\rho$  is the air density,  $U$  is the free-stream velocity, and  $\theta$  is the angle between the radius to the point at the surface and the direction of the flow.

Observation shows (Milne-Thompson, 1950, p. 152) that in real viscous flows, the pressure distribution about the forward part, within about  $30^\circ$  of the flow direction, approximates the theoretical distribution.

The pressure distribution shows little relation to the theoretical over the rest of the surface of the cylinder.

If the axis of the cylinder be inclined to the direction of the flow, we find, in theory, that the flow may be resolved into two components, one along the cylinder, producing no change of pressure at the surface of the cylinder; the other perpendicular to the cylinder, producing the pressure distribution of equation (2) but with  $U$  now replaced by  $U_n$ , the normal component of flow. While experimental data is not readily available, it does appear that this resolution is achieved with some accuracy over the region of validity of equation (2), particularly if the flow strikes the cylinder at near right angles.

#### B. The Rotating Arm

Let us take a cylinder such as we have described and rotate it about an axis perpendicular to the axis of the cylinder (Figure 1). Let the axis of rotation be horizontal, and let the direction of the mean wind lie in the plane of rotation of the cylinder. At time  $t$ , the cylinder, being rotated with angular velocity  $\omega$ , is at an angle  $\theta$  to the horizontal. At the same time, the projection  $V$  of the wind vector on the plane of rotation makes an angle  $\alpha$  with the horizontal,  $\alpha$  being positive for winds with an upward component. A small pressure hole is located on the leading edge of the cylinder at distance  $R$  from its axis of rotation.

Let us for the moment ignore winds out of the plane of rotation of the cylinder. In Figure 1, the component of the wind normal to the cylinder is

$$V_n = V \sin(\theta - \alpha) \quad (3)$$

FIGURE 1

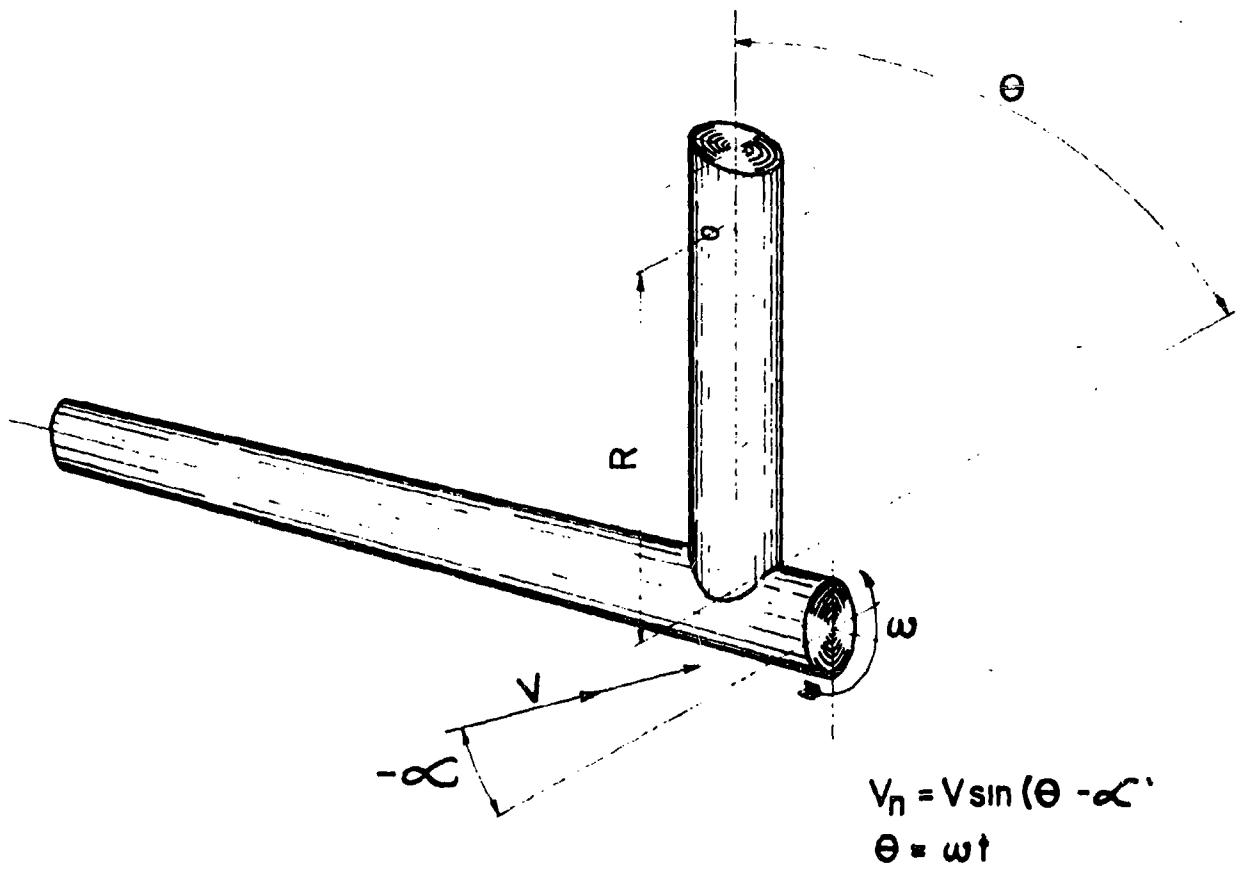

ROTATING ARM ANEMOMETER  
SCHEMATIC

If we let  $\theta = \omega t$  (arm horizontal at  $t = 0$ ), the pressure on the hole will be given by

$$\begin{aligned}
 p &= \frac{1}{2} \rho [\omega R + V_n]^2 = \frac{1}{2} \rho [\omega R + V \sin(\omega t - \alpha)]^2 = \\
 &\frac{1}{2} \rho [\omega^2 R^2 - 2\omega R V \sin \alpha \cos \omega t + 2\omega R V \cos \alpha \sin \omega t + \\
 &\frac{V^2}{2} - \frac{V^2}{2} \cos 2\alpha \cos 2\omega t - \frac{V^2}{2} \sin 2\alpha \sin 2\omega t \quad (4)
 \end{aligned}$$

It will be noted that aside from non-periodic terms, first and second harmonic terms are present, the first harmonic terms linear in  $V$ , the second harmonic quadratic. It is of interest to note that the first harmonic is a linear measure of wind speed; it is from this that the power of this method is derived.

The pressure present at the pressure hole may be piped down hollow shafting and converted to an alternating voltage by an appropriate pressure transducer. Some attention must be paid to the ducting to avoid attenuation of the pressure wave. Since the pressure hole is necessarily small, it is essential that the amount of air movement through the hole be kept as slight as possible to prevent serious pressure drops at that point. This is accomplished principally by the use of a transducer with a stiff diaphragm. Compressibility effects are negligible unless the ducting has large volume. Resonance is avoided by keeping the duct shorter than a quarter-wave organ pipe of the highest frequency to be measured.

The voltage output of the transducer will be  $\mu p$ , where  $\mu$  is the appropriate factor of proportionality.

### C. Obtaining the wind velocity

A number of methods may be used to recover the wind velocity. Filtering is the most obvious, but does not easily permit the recovery of

the angle of the wind. The method chosen here is phase rectification, which makes use of the familiar orthogonality principles:

$$\lim_{T \rightarrow \infty} \frac{1}{T} \int_0^T \sin at \sin bt \, dt = \lim_{T \rightarrow \infty} \frac{1}{T} \int_0^T \cos at \cos bt \, dt = 0 \quad (a \neq b) \quad (5)$$

and  $\lim_{T \rightarrow \infty} \frac{1}{T} \int_0^T \sin at \cos bt \, dt = 0$

$$\lim_{T \rightarrow \infty} \frac{1}{T} \int_0^T \sin^2 at \, dt = \lim_{T \rightarrow \infty} \frac{1}{T} \int_0^T \cos^2 at \, dt = \frac{1}{2} \quad (6)$$

so that if we multiply  $\mu p$  from (3) electrically by  $\sin \omega t$  and obtain an average, we have

$$\frac{1}{T} \int_0^T \mu p \sin \omega t \, dt \approx \frac{1}{2} \mu \omega R (V \cos \alpha) \quad (7)$$

The approximation improves with increase of averaging time  $T$ , but if the spectra of  $V$  and  $\alpha$  do not contain significant harmonic components of frequency  $\frac{\omega}{2\pi}$ , the approximation is excellent after a very few cycles.

The quantity  $V \cos \alpha$  will be recognized as the horizontal component of the wind velocity in the plane of rotation of the cylinder. If we multiply  $\mu p$  by  $\cos \omega t$  and integrate, we have

$$\frac{1}{T} \int_0^T \mu p \cos \omega t \, dt \approx \frac{1}{2} \mu \omega R (V \sin \alpha) \quad (8)$$

where the quantity  $V \sin \alpha$  is the vertical component of the wind velocity.

The horizontal and vertical components may be separately recorded.

#### D. The Shearing Stress

A rather surprising feature of the instrument appears if we isolate the second harmonic component of the pressure signal by multiplying by  $\sin 2 \omega t$  and averaging:

$$\frac{1}{T} \int_0^T \mu p \sin 2 \omega t \, dt \approx -\frac{1}{4} \mu \omega V^2 \sin 2 \alpha \quad (9)$$

Since  $V^2 \sin 2\alpha = 2 V^2 \sin \alpha \cos \alpha$ ,

$$\frac{1}{T} \int_0^T \mu p \sin 2\omega t dt \approx -\frac{1}{2} \mu \rho (V \sin \alpha) (V \cos \alpha) = -\frac{1}{2} \mu \rho u w \quad (10)$$

where  $\frac{\mu \rho u w}{2}$  will be recognized as the shearing stress or the vertical flux of horizontal momentum. Because of calibration difficulties, this relation has not yet been exploited, but it is planned to do so at the earliest opportunity.

#### E. Effect of cross wind

Thus far it has been assumed that the wind is in the plane of rotation of the cylinder. In general, the wind will have an additional component perpendicular to the plane of rotation. It would be desirable that the instrument ignore this component, so that direct readings of  $u$  and  $w$  may be obtained. It can readily be seen that this condition would be satisfied if equation (2) read

$$p_d - \pi = \frac{1}{2} \rho u^2 \cos^2 \beta \quad (11)$$

This differs from equation (2) by

$$p' = -\frac{3}{2} \rho u^2 \sin^2 \beta \quad (12)$$

or fractionally,

$$\frac{p'}{p_d - \pi} = -3 \tan^2 \beta \quad (13)$$

$\beta$  has its maximum value when the cylinder is retreating with the wind

$$\tan \beta_{\max} = \frac{v}{\omega R - V} \quad (14)$$

where  $v$  is the cross-component of the wind, the other notation as before.

The minimum value is found where the cylinder is advancing into the wind

$$\tan \beta_{\min} = \frac{v}{\omega R + V} \quad (15)$$

It will be seen that this varying  $\beta$  gives rise to a spurious pressure alternation of amplitude approximately

$$|P'| = \frac{3}{4} \rho \omega^2 R^2 \left[ \frac{v^2}{(\omega R - V)^2 + v^2} - \frac{v^2}{(\omega R + V)^2 + v^2} \right] = \rho \omega R V \left[ \frac{3\omega^2 R^2 v^2}{(\omega^2 R^2 + V^2 + v^2)^2} \right] \quad (16)$$

and of the same phase (but opposite sign) as the first harmonic  $\rho \omega R V$ .

In a typical case, we may take

$$v_{\max} = 0.3 \bar{v} \quad (\text{Friedman, 1953}) \quad (17)$$

Then the bracketed quantity in equation (16) has the value .053, corresponding to a decrease in instrument response of some 5%.

While this quantity is by no means insignificant, it cannot be considered as a source of major error.

#### F. Conclusion

It will be seen from the foregoing that the principle of operation, while perhaps somewhat involved trigonometrically, is reasonably straightforward. Perhaps the most attractive feature of the instrument is its enforced linearity of operation; any non-linearity appearing at any point in the alternating pressure or voltage system appears as a higher harmonic, and is rejected by the rectification system. Tests of the system have shown such false higher harmonics to be insignificant in magnitude.

### III. Mechanical Features

The first model of the resolving anemometer, which forms the subject of this report, was rather elementary in construction and perhaps somewhat crude.

It consisted of an angle iron framework supporting the rotating arm mechanism at 120 cm from the ground. It was oriented into the mean wind by hand. The mechanism was designed to rotate a short arm at 1500 r.p.m. This relatively high rate of rotation was chosen because of the convenience of the 25 cycles per second frequency produced and because of the availability of standard 25 and 50 cycle components for computational use.

Details of construction:

(1) A hollow shaft (one-half inch outside diameter) supported by bearings at each end, with provision for mounting the rotating arm at the center of the shaft.

(2) One of the bearings forms a rotating shaft seal to permit transmission of the pressure to a stationary pressure transducer.

(3) Drive shafting and gearing to permit rotation of the shaft by a rather bulky motor without interference with the air stream. The right-angle gearing was through unenclosed spiral miter gears, speed reduction at the motor through unenclosed fiber and steel spur gears. Rates of rotation were somewhat excessive for this type of gearing, and it was found impossible to keep even special corn-picker grease on them. As a result they howled distressingly, although wear did not seem serious.

(4) Generator to produce the necessary reference voltage at phases fixed with respect to the position of the rotating arm. An Electric Indicator Co. type F-16 A-C rate generator was used, providing two alternating voltages of excellent harmonic purity and quite accurately in quadrature with each other. This was geared to the drive motor to produce a

frequency of 25 cycles per second. Provision was made for rotational adjustment of the body of the generator to permit accurate phasing.

(5) Drive motor, Bodine synchronous type NSY-55, 1/8 h.p. A synchronous motor was chosen to permit accurate maintenance of rate of rotation, so that calibration would be as stable as possible and rotational transients would be minimized. The synchronous motor is considerably bulkier than an ordinary A-C motor of the same power, and somewhat noisier.

(6) Pressure transducer, Statham Laboratories Model P58-O.15D-1400, chosen for its sensitivity and its high resonant frequency (275 cps), which permits it to follow the relatively high frequency alternating pressure (25 and 50 cps) without attenuation or distortion. The transducer was shockmounted together with its preamplifier and connected to the rotating pressure joint by a short length of stiff plastic tubing. The total pneumatic circuit was about 40 cm in length, which compares quite favorably with the 166 cm length of a 50-cycle 1/4-wave organ pipe.

(7) The rotating arm itself. A number of different configurations were tried, but none seemed any more effective than a simple cylindrical tube of 3/16 inch outside diameter, 15 cm in length, with a .045 inch hole drilled about 12 cm from the axis of rotation. This produced a circumferential speed of the pressure hole of just under 20 m/second at a rotational rate of 25 rps.

The total ensemble was somewhat bulky and distinctly noisy in operation. An improved model, under construction at the time of this report, will have better characteristics.

#### IV. Electronic Circuitry

A wide range of electronic circuits may be used, probably with equal success, to reduce the electrical output of the pressure transducer

(equation 4) to the desired form for recording. Each must perform the following operations:

(1) Amplification of the relatively weak signal from the pressure transducer.

(2) Phase demodulation. This is essentially multiplication by the appropriate trigonometric function. (See equation (7)).

(3) Integration. This may be an actual integration, but resistance-capacitance pseudo-integration is far more convenient for purposes of indication. The time constant of the resistance-capacitance integrator establishes the effective time constant of the instrument.

All circuits that have been used in this first model are quite standard and will not be reproduced here. Figure 2 gives a block diagram of the system.

The pressure transducer is of a strain-gauge bridge type, producing a signal of the order of a few millivolts. Amplification brings it up to a few volts amplitude.

The phase rectifiers chosen were of the type using addition of voltages at the grids of a pair of push-pull cathode followers. This type of rectifier multiplies the input signal by what is essentially a square wave rather than by a sine function. A square wave is composed only of odd harmonics, so that there is nothing in the input signal that will produce spurious response. Any odd harmonics generated by harmonic distortion in the transducer or amplifier will be recovered at this point.

The phase rectifiers contain as an integral part the resistance-capacitance network that produces pseudo-integration (a running mean process). Time constants were set at 0.5 seconds to produce a reasonably smooth record on the recorder used. This relatively large time constant

FIGURE 2

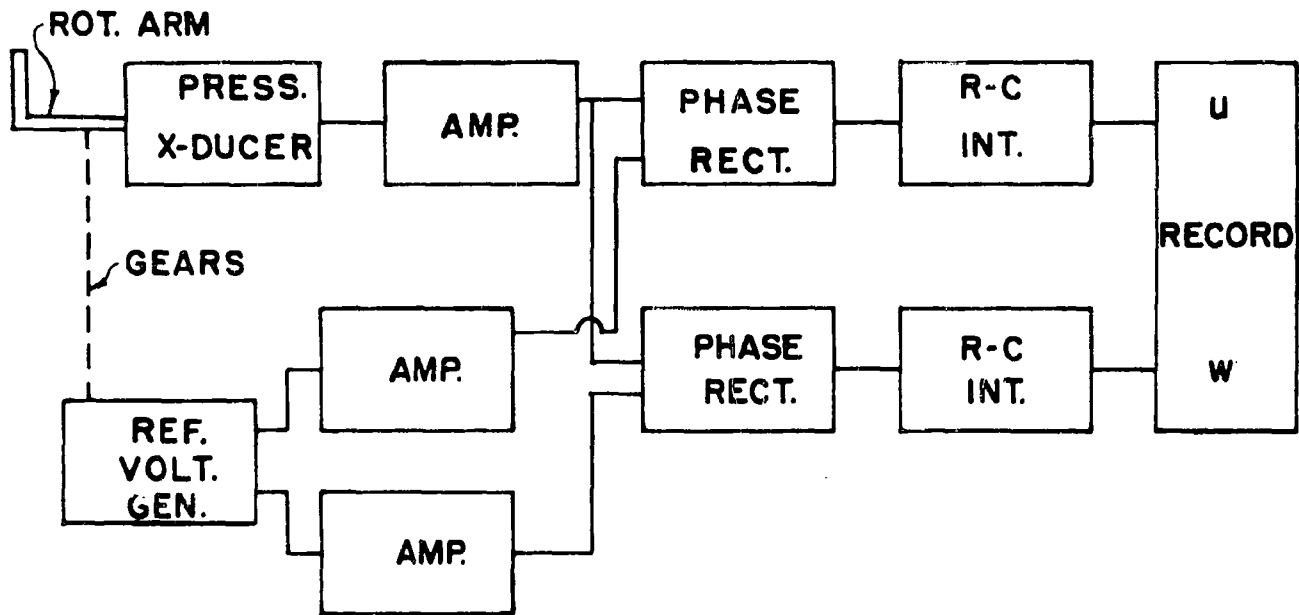

ROTATING ARM ANEMOMETER  
COMPUTER SYSTEM

is a matter of convenience rather than of necessity; it represents 12.5 cycles at 25 cps, which is probably more than enough to make the approximation of equation (7) excellent for most atmospheric conditions.

A two-channel Brush recorder was used to produce a graphic record, with 1 cm of chart length representing one second. The speed of response of the recorder is so high that it does not add appreciably to the time constant of the system. Appropriate scaling voltage dividers were introduced earlier in the system to expand the scale of the vertical component relative to that of the horizontal.

Isolating amplifiers with negligible phase shift were introduced between the reference voltage generator and the phase rectifiers largely as a precautionary measure.

Once the few initial "bugs" were removed, the electronic system performed fairly satisfactorily.

## V. Performance

### A. General

The basic instrument was tested at the Air Force Cambridge Research Center's Great Plains Turbulence Field Program, held at O'Neill, Nebraska, during August and the early part of September 1953. It functioned approximately as calculated under all but light wind conditions, when the rotating arm set up a circulation that gave completely spurious results.

Figure 5 shows a short length of the record obtained with the instrument. The excellent time resolutions will be noted, as well as the relatively open scale for the vertical velocity.

Actual operation of the instrument was somewhat more complex than had been originally hoped. It was found that the D-C output of the phase rectifiers had a strong tendency to drift in spite of the relatively high levels at which they were operated. This necessitated frequent zeroing of the apparatus. The phase rectifiers occasionally overloaded on strong transients and would give obviously spurious indications until they had recovered from the overload. This prevented operation at anywhere near full-scale of the recorder, and required frequent range-switching as wind velocities and turbulence increased or decreased.

### B. Light Winds

Operation in light winds set up a whirl about the rotating arm that gave a record suggesting the wind approaching the instrument at some angle to the horizontal. For not-too-light winds, this angle was not too great, and could fairly well be compensated for by a slight rotation of the phase of the reference voltages. However, it is felt that this procedure has little to recommend it, as it is not known to what extent this may distort the record.

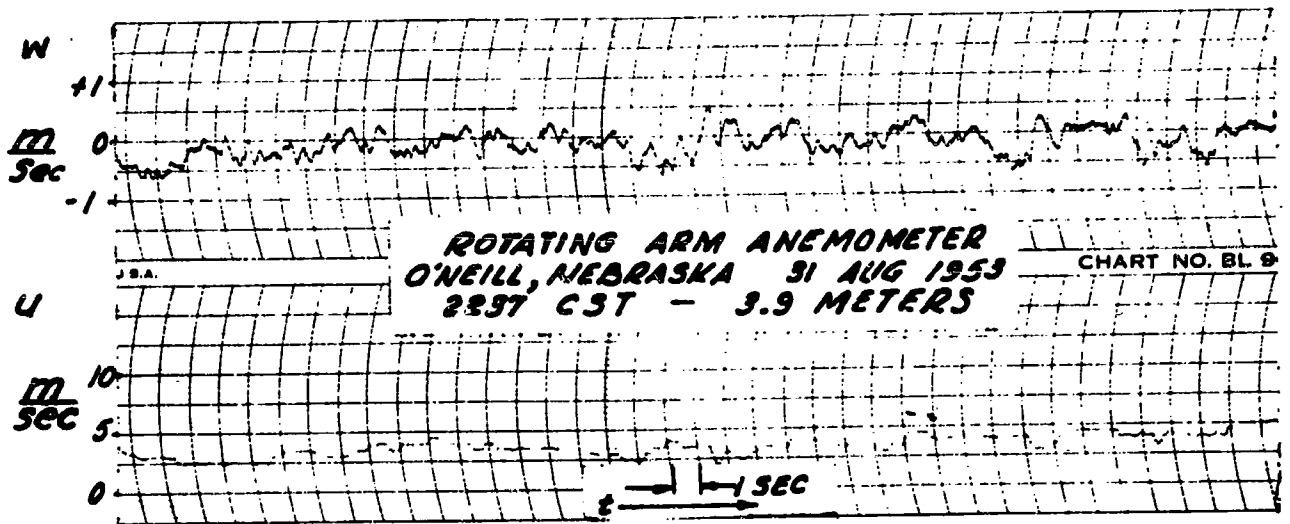

A SAMPLE RECORD - FIGURE 3

Figure 4 shows the apparent angle of the wind found for a 1/4" diameter cylindrical arm. Data are not yet available to indicate the relation of cylinder diameter to this effect. As a rough estimate, it might be anticipated that it will be in proportion to the diameter and would be reduced for a streamlined profile.

#### C. Comparison with other Instruments

Unfortunately, it was not possible to make a side-by-side comparison of the output of the rotating arm anemometer with another instrument measuring the same quantities. An attempt was made to compare it with the Sonic Anemometer of Prof. Suomi of the University of Wisconsin, but because of dissimilar presentations of data, only very general agreement could be established.

The observations made at O'Neill will be the subject of another report.

### VI. Proposed Further Development

#### A. Fluxmeter

The circuit of Figure 2 may be expanded without great increase of complexity to that of a fluxmeter for the measurement of the vertical flux of heat or moisture. In this case, multiplication of the velocity by the temperature or by the mixing ratio may be accomplished by passing the signal from the transducer through an appropriate resistance bridge circuit before phase demodulation.

#### B. Counter-rotating Arm System

Design calculations indicate that much of the error resulting from the circulation caused by the arm in low wind speeds can be avoided by building the instrument with two counter-rotating arms, the difference in

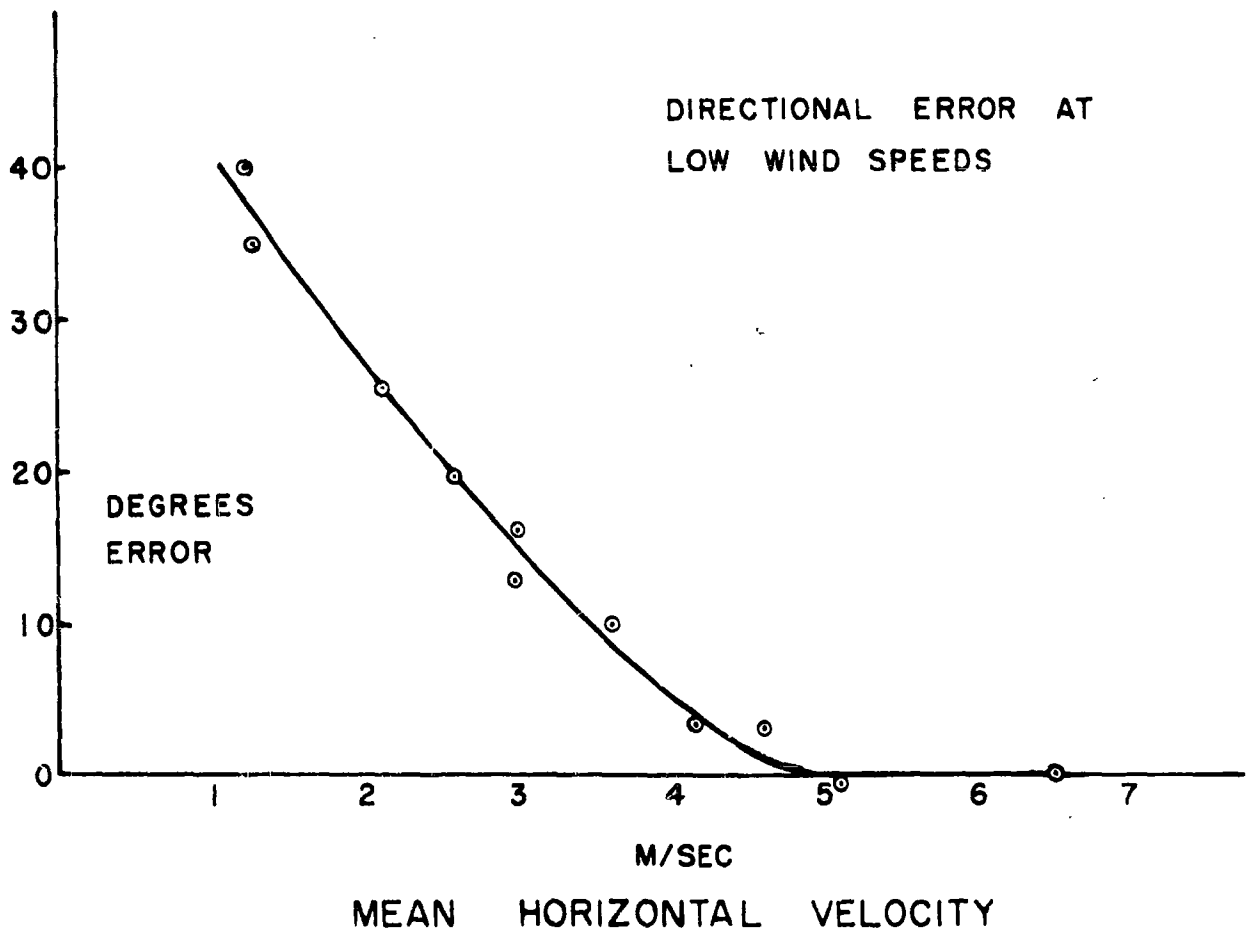

FIGURE 4

pressure between the two leading edges being measured. The signal corresponding to the horizontal velocity is cancelled out, however. This causes some loss of general utility, but is, if anything, desirable for use of the instrument as a vertical fluxmeter. Cancellation of the relatively large horizontal signal permits greater accuracy in the handling of the vertical component. It is found that the only other signal retained after cancellation is that of the shearing stress (see equation (10)), which should become quite manageable. Such a counter-rotating arm system with associated gearing and pressure ducting is under construction.

#### VII. Concluding Remarks

The rotating arm anemometer as presented here, while not a finished instrument, shows enough promise of becoming a useful addition to the instrumentation of micrometeorology to justify the further development outlined above.

Perhaps its greatest utility may come in introducing a somewhat new concept in meteorological instrumentation - that of rotating a sensing element in a field of a variable. A fairly obvious example is the rotation of a thermal element in a large vertical circle to measure the vertical gradient of temperature. The use of a single element eliminates many of the difficulties frequently encountered with this measurement.

It is believed that the completed fluxmeter assembly will be capable of amassing large quantities of useful data in easily assimilable form. If its operation can be reduced to a fairly simple routine, it may become of considerable utility in general micrometeorological research.

#### REFERENCES

- Friedman, Don G., 1953: The height variation of lateral gustiness and its effect on lateral diffusion, *J. Met.* 10, 372-379.
- Gill, G. C., 1954a: A fast response anemometer for micrometeorological investigations, *BAMS* 32, 69-75.
- Gill, G. C., 1954b: A fast response bivane for micrometeorological investigations, (to be published).
- Inoue, Eiich, 1954: On the smallest scale of turbulence in the atmosphere, Texas A & M Research Foundation, ONR contract N7onr-48705, Technical Report No. 1.
- MacCready, Paul B., Jr., 1953a: Atmospheric turbulence measurements and analysis, *J. Met.* 10, 325-337.
- MacCready, Paul B., Jr., 1953b: Structure of atmospheric turbulence, *J. Met.* 10, 434-449.
- Mazzarella, Daniel A., 1952: An all weather, remote recording bivane, *BAMS* 30, 60-66.
- Milne - Thompson, L. M., 1950: "Theoretical Hydrodynamics", New York, MacMillan.
- Parson, D., Jr. and A. F. Burkner, 1952: A recording computer for the direct measurement of the turbulent heat exchange in the atmosphere, International Symposium on Atmospheric Turbulence in the boundary layer, M. I. T., Air Force Cambridge Research Center, Geophysical Research Papers No. 19, 359-379.
- Shiotani, M., 1950: Turbulence in the lowest layers of the atmosphere, *Sci. Rep. of the Tôhoku Univ.*, Ser. 5, 2, 167-201.
- Swinbank, W. C., 1951: The measurement of vertical transfer of heat and water vapor by eddies in the lower atmosphere, *J. Met.* 8, 133-145.

PROJECT 59; Distribution List

Geophysics Branch  
Office of Naval Research  
Washington 25, D.C.  
Attn: Code 416 (2)

Director, Naval Research Laboratory  
Washington 25, D.C.  
Attn: Technical Information Officer (6)

Officer-in-Charge  
Office of Naval Research  
London Branch Office  
Navy No. 100, Fleet Post Office  
New York, New York (2)

Office of Naval Research Branch Office  
346 Broadway  
New York 13, New York (1)

Office of Naval Research Branch Office  
The John Crerar Library Building  
86 East Randolph Street, Tenth Floor  
Chicago, Illinois (1)

Office of Naval Research Branch Office  
1030 East Green Street  
Pasadena 1, California (1)

Office of Naval Research Branch Office  
1000 Geary Street  
San Francisco, California (1)

Office of Technical Services  
Department of Commerce  
Washington 25, D.C. (1)

Armed Services Tech. Information Center  
Documents Service Center  
Knott Building  
Dayton 2, Ohio (5)

Assistant Secretary of Defense for  
Research & Development  
Pentagon Building  
Washington 25, D.C.  
Attn: Com. on Geophysics & Geography (1)

Mr. Francis M. Lucas  
ONR Resident Representative  
University of Texas  
Main Building, Room 2506  
Austin 12, Texas (1)

Department of Aerology  
U. S. Naval Postgraduate School  
Monterey, California (1)

Aerology Branch  
Bureau of Aeronautics (Ma-5)  
Navy Department  
Washington 25, D.C. (1)

Mechanics Division  
Naval Research Laboratory  
Anacostia Station  
Washington 20, D.C.  
Attn: J. E. Dinger, Code 3820 (1)

Radio Division I, Code 3420  
Naval Research Laboratory  
Anacostia Station  
Washington 20, D.C. (1)

Meteorology Section  
Navy Electronics Laboratory  
San Diego 52, California  
Attn: L. J. Anderson (1)

Library, Naval Ordnance Laboratory  
White Oak  
Silver Spring 19, Maryland (1)

Bureau of Ships, Navy Department  
Washington 25, D.C.  
Attn: Code 851, (Special Devices Center)(1)

Bureau of Ships, Navy Department  
Washington 25, D.C.  
Attn: Code 327, (Technical Library) (2)

Chief of Naval Operations  
Navy Department  
Washington 25, D.C.  
Attn: Op-533D (2)

Oceanographic Division  
U. S. Navy Hydrographic Office  
Suitland, Maryland (1)

Library, Naval Ordnance Test Station  
Inyokern, China Lake, California (1)

Project AROWA, U. S. Naval Air Station  
Building R-48  
Norfolk, Virginia (2)

The Chief  
Armed Forces Special Weapons Project  
P. O. Box 2610  
Washington, D.C. (1)

Office of the Chief Signal Officer  
Engineering and Technical Service  
Washington 25, D.C.  
Attn: SIGGCM (1)

Meteorological Branch  
Evans Signal Laboratory  
Belmar, New Jersey (1)

Office of the Quartermaster General  
2nd and T. Sts.  
Washington 25, D.C.  
Attn: Environmental Protection Section(1)

Commanding Officer  
Air Force Cambridge Research Center  
230 Albany Street  
Cambridge, Massachusetts  
Attn: ERHS-1 (1)

Headquarters, Air Weather Service  
Andrews A. F. Base  
Washington 20, D.C.  
Attn: Director Scientific Services (2)

Office of the Chief, Chemical Corps  
Research and Engineering Division  
Research Branch  
Army Chemical Center, Maryland (2)

Commanding General, Air Materiel Command  
Wright Field  
Dayton, Ohio  
Attn: MCREEO (1)

Commanding General  
Air Force Cambridge Research Center  
230 Albany Street  
Cambridge, Massachusetts  
Attn: CRHSL (1)

Commanding General  
Air Research & Development Command  
P.O. Box 4395  
Baltimore 3, Maryland  
Attn: RDDG (1)

Department of Meteorology  
Massachusetts Institute of Technology  
Cambridge, Massachusetts  
Attn: H. G. Foughton (1)

PROJECT 59: Distribution List-Cont'd.

Department of Meteorology  
University of Chicago  
Chicago 37, Illinois  
Attn: H. K. Byers (1)

Institute for Advanced Study  
Princeton, New Jersey  
Attn: J. von Neumann (1)

Scripps Institution of Oceanography  
La Jolla, California  
Attn: R. Revelle (1)

General Electric Research Laboratory  
Schenectady, New York  
Attn: I. Langmuir (1)

St. Louis University  
3621 Olive Street  
St. Louis 8, Missouri  
Attn: J. B. Macelwane, SJ. (1)

Department of Meteorology  
University of California at Los Angeles  
Los Angeles, California  
Attn: M. Neiburger (1)

Department of Engineering  
University of California at Los Angeles  
Los Angeles, California  
Attn: L. M. K. Hoelter (1)

Department of Meteorology  
Florida State University  
Tallahassee, Florida  
Attn: W. A. Baum (1)

Woods Hole Oceanographic Institution  
Woods Hole, Massachusetts  
Attn: C. Iselin (1)

The Johns Hopkins University  
Department of Civil Engineering  
Baltimore, Maryland  
Attn: R. Long (1)

The Johns Hopkins University  
Department of Physics, Homewood Campus  
Baltimore, Maryland  
Attn: G. Plass (1)

New Mexico Institute of Mining & Technology  
Research and Development Division  
Socorro, New Mexico  
Attn: E. Workman (1)

University of Chicago  
Department of Meteorology  
Chicago 37, Illinois  
Attn: H. Riehl (1)

Woods Hole Oceanographic Institution  
Woods Hole, Massachusetts  
Attn: A. Woodcock (1)

General Electric Research Laboratory  
Schenectady, New York  
Attn: V. Schaefer (1)

Geophysical Institute  
University of Alaska  
College, Alaska  
Attn: C. T. Elvey (1)

Blue Hill Meteorological Observatory  
Harvard University  
Milton 86, Massachusetts  
Attn: C. Brooks (1)

Laboratory of Climatology  
Johns Hopkins University  
Seabrook, New Jersey (1)

Department of Meteorology  
New York University  
New York 53, New York  
Attn: S. Haurwitz (1)

Massachusetts Institute of Technology  
Department of Meteorology  
77 Massachusetts Avenue  
Cambridge 39, Massachusetts  
Attn: T. F. Malone (1)

Rutgers University  
College of Agriculture  
Department of Meteorology  
New Brunswick, New Jersey (1)

National Advisory Committee of Aeronautics  
1500 New Hampshire Avenue, N.W.  
Washington 25, D.C. (2)

U. S. Weather Bureau  
24th & M Sts., N.W.  
Washington 25, D.C.  
Attn: Scientific Services Division (2)

Air Coordinating Committee  
Subcommittee on Aviation Meteorology  
Room 2D889-A, The Pentagon  
Washington, D.C. (1)

American Meteorological Society  
3 Joy Street  
Boston 8, Massachusetts  
Attn: The Executive Secretary (1)

Research Professor of Aerological Engineering  
College of Engineering  
Department of Electrical Engineering  
University of Florida  
Gainesville, Florida (1)

Director of Technical Services  
headquarters, Dugway Proving Grounds  
Dugway, Utah (1)