

UNCLASSIFIED

AD NUMBER

AD045850

LIMITATION CHANGES

TO:

Approved for public release; distribution is unlimited.

FROM:

Distribution authorized to U.S. Gov't. agencies and their contractors;
Administrative/Operational Use; 05 AUG 1954.
Other requests shall be referred to Naval Ordnance Laboratory, White Oak, MD 20993.

AUTHORITY

USNOL ltr, 29 Aug 1974

THIS PAGE IS UNCLASSIFIED

med Services Technical Information Agency

Because of our limited supply, you are requested to return this copy WHEN IT HAS SERVED YOUR PURPOSE so that it may be made available to other requesters. Your cooperation will be appreciated.

D

45850

NOTICE: WHEN GOVERNMENT OR OTHER DRAWINGS, SPECIFICATIONS OR OTHER DATA ARE USED FOR ANY PURPOSE OTHER THAN IN CONNECTION WITH A DEFINITELY RELATED GOVERNMENT PROCUREMENT OPERATION, THE U. S. GOVERNMENT THEREBY INCURS NO RESPONSIBILITY, NOR ANY OBLIGATION WHATSOEVER; AND THE FACT THAT THE GOVERNMENT MAY HAVE FORMULATED, FURNISHED, OR IN ANY WAY SUPPLIED THE SAID DRAWINGS, SPECIFICATIONS, OR OTHER DATA IS NOT TO BE REGARDED BY ANY PERSON OR CORPORATION, OR CONVEYING ANY RIGHTS OR PERMISSION TO MANUFACTURE, REPRODUCE OR SELL ANY PATENTED INVENTION THAT MAY IN ANY WAY BE RELATED THERETO.

Reproduced by
DOCUMENT SERVICE CENTER
KNOTT BUILDING DAYTON 2 OHIO

UNCLASSIFIED

AD No. 45850

ASTIA FILE COPY

NAVORD REPORT 3670

A STUDY OF THE EFFECTS OF STATIC ELECTRICITY ON LOW INPUT ENERGY
ELECTRIC INITIATORS OF THE CARBON BRIDGE TYPE

5 AUGUST 1954



U. S. NAVAL ORDNANCE LABORATORY
WHITE OAK, MARYLAND

A STUDY OF THE EFFECTS OF STATIC ELECTRICITY
ON LOW INPUT ENERGY ELECTRIC INITIATORS OF
THE CARBON BRIDGE TYPE

Prepared by:
J. N. Ayres

ABSTRACT: At various ordnance installations, a number of accidents with carbon-bridge electric initiators have been noted. A study of these accidents plus experimentation at the Naval Ordnance Laboratory demonstrate that this type of electric initiator is extremely susceptible to initiation by the electrostatic discharges. Initiations have been caused under the following conditions of application of potential differences to the initiator structure, lead-to-lead, lead-to-case, leads-to-case, and to center of leads with lead ends and case electrically shorted. It has been found that some operator grounding systems such as dangling chains, conductive shoes, and wrist bands are sometimes ineffective. It has been found that an ungrounded operator can accumulate an electrostatic charge not only by friction processes, but also by capacitive induction. It is felt that electric initiators can be handled safely, or at least with minimum risk, by the application of a few basic principles. The principles are not here abstracted since any abridgment could lead to misinterpretation.

U.S. NAVAL ORDNANCE LABORATORY
WHITE OAK, MARYLAND

ACKNOWLEDGEMENTS

Considerable theoretical and practical effort leading to this report can be credited to Mr. H.W.L. Street of this Laboratory. Invaluable assistance has been received from Mr. Westin and Mr. Herd also of this Laboratory. In fact, the author has noted eager assistance wherever he has had occasion to work on this problem in Navy, Army, contractor and research establishments.

5 August 1954

This report is not a complete presentation of all aspects of handling problems arising from the susceptibility of certain electrical explosive initiators to initiation by electrostatic discharge. It has been written to make known and delineate problem areas which, it is felt, have not previously been generally recognized. It is intended as a sort of "storm warning", in the hope that future accident frequencies from such phenomena can be reduced, and in the hope that the recognition of the problems will lead to improved methods for coping with these problems.

This work was performed in connection with Task NOL-B2b-1-1, Problem 3.

JOHN T. HAYWARD

R. E. HIGHTOWER
By direction

CONTENTS

	Page
Introduction	1
Events of 1 October and 8 October Accidents.	3
1 October 1953	3
8 October 1953	3
Environment of 1 October and 8 October Accidents	4
Explanation of 1 October Accident.	8
Explanation of 8 October Accident.	9
20 November Accident	13
2 December Accident.	17
Explanation of 20 November and 2 December Accidents.	18
27 February Accident	21
Accident at Franklin Institute	23
Theory, Fact, and Rumor.	24
Outlook.	25
Modes of Initiation.	25
The Theory and Utilization of the Faraday Shield	29
Problems and Techniques of Grounding	30
Ways in Which Static Charges Can Be Formed	34
Long Range Approaches to the General Problem	36
Safety Concepts.	37
Control of Electrostatic Charges	39

NAVORD Report 3670

ILLUSTRATIONS

	Page
Figure 1. Operation Environment During 1 October and 8 October Accidents	6
Figure 2. Wristlets Worn During 1 and 8 October Accidents	7
Figure 3. Photographs of the Ready Box Involved in the 1 October Accident	10
Figure 4. Suggested Arrangement of Test Set Mk 162-1 Circuit	12
Figure 5. Views of the Assembly and Polythene Bag of the Type That Figured in the 20 November and 2 December Accidents	14
Figure 6. Table Arrangement Prior to First Accident at Plant B	15
Figure 7. Removing Assembly From Plastic Bag	16
Figure 8. Unpackaging Station at Plant B on 2 December	17
Figure 9. Explanation of Charging Action Through Plastic Bag	20
Figure 10. Symbolic Representation and Circuit Analysis of the Essential Factors of the 27 February Accident	22
Figure 11. Physical Arrangement of a Carbon Bridge Initiator	26
Figure 12. Setup to Demonstrate Sensitivity of Initiator With Grounded Case and Leads to Energy Pulses	28
Figure 13. Method of Pulsing Setup Shown in Figure 12	29
Figure 14. Recommended Grounding Wrist Bracelet	33
Figure 15. Capacitive Induction	35

NAVORD Report 3670

A STUDY OF THE EFFECTS OF STATIC ELECTRICITY ON LOW INPUT ENERGY ELECTRIC INITIATORS OF THE CARBON BRIDGE TYPE

INTRODUCTION

1. It is not yet widely enough recognized just how difficult it is to handle certain types of electro-explosive devices safely. Some of the handling hazards are not self-evident nor are the procedures for controlling them. Many of the dangers are insidious in that they do not act except upon a comparatively improbable combination of adverse factors. Many cases are known where the handling of these primers apparently has been accompanied by the most flagrant violation of safe handling requirements without any mishap. A record of low accident rate in the face of poor handling techniques can lead to faulty reasoning, resulting in the decision that the existing techniques are adequate and that better practices represent an unnecessary expenditure of time and money. What is not realized is that a low accident rate under such circumstances may only be proof that the operations have been accompanied by good fortune, in the past. It is not a proof that this good fortune will continue.

2. There are known instances where better than average precautions had been established and observed, and where as a wry twist of fate, these precautions were found to be ineffective. Some of these instances will be reported and the most probable explanation of circumstances will be given. The main purpose of this report is to describe the known hazards and show the principles that can be applied to control these hazards. In this report the descriptions of a number of accidents will be used for emphasis and are not intended to pinpoint responsibility. These accidents will be reviewed briefly in the next paragraph to present an overall picture. Detailed presentations and reconstructions will be given in the following paragraphs. The theoretical aspects of the problem area will then be covered in some detail. Finally, those principles will be set forth which, it is felt, are the best guides presently known by means of which an operational system can be evaluated for its safety.

3. The detailed descriptions of each of the accidents are to be found in the paragraphs referenced.

NAVORD Report 3670

a. In Plant A on 1 October 1953, a girl, wearing a grounded wrist strap, was checking the resistance of Mk 124, carbon bridge primers. As she placed a checked primer into the ready box, the primer exploded, blowing a hole in the side of the box and injuring the operator somewhat. (See Paras. 4, 6-15)

b. On 8 October 1953, at the same plant, another girl was performing the same operation at another station in the line. The primer exploded inside the safety chamber with very slight injury to the operator. As in the previous accident, the operator was wearing a grounded wrist strap. (See Paras. 5-10, 16-21)

c. On 20 November 1953, at Plant B, an accident occurred during the handling of the assemblies manufactured by Plant A. This operation involved the removal of the assembly from a plastic shipping bag. At all times after the assembly is completed the primer is supposedly shorted electrically. Yet, as the assembly was dumped out of the plastic bag, the primer fired, the operator suffering burns and lacerations about the face and chest but without damage to eyes. (See Paras. 22-31)

d. On 2 December 1953, at Plant B, another accident occurred in conjunction with the removal of the plastic bag from the assemblies, except that in this case the assembly was still inside the bag. (See Paras. 26-31)

e. On 27 February 1953, at Plant C, a short across a Mk 121 primer was being unsoldered by a quick heating, trigger action, transformer type soldering gun. After the shorter wire was disconnected, the trigger of the soldering gun was released while the gun tip was still in contact with the terminal leading to the primer. The primer fired at the instant of trigger release. (See Paras. 32-34)

f. At the Franklin Institute in August 1952, an accident occurred under circumstances rather difficult to explain. The head of a T18E4 detonator was inside a firing chamber with the leads coming forward to terminals which were probably ungrounded. The leads, which were twisted together, were clipped below the terminals to cut off the twisted section and thereby unshort the detonator. At the instant of clipping the leads with grounded cutters, the detonator fired. Apparently the detonator and terminal assembly had become charged with respect to ground. The grounding of the leads transferred the potential difference to the case-lead system. (See Paras. 35-37)

NAVORD Report 3670

g. Instances of initiation of primers and detonators have been found during their insertion in or removal from plastic lined metal foil envelopes. The plastic coating on the foil is apparent only on close inspection or by electrical testing. (See Para. 38)

EVENTS OF 1 OCTOBER AND 8 OCTOBER ACCIDENTS

4. 1 October 1953. At Plant A, an accidental explosion of a Mk 124 Primer occurred at one of the stations of the resistance checking line. One operational cycle at this station is as follows:

a. Remove one primer from the foil wrapped bundle of untested primers. (The bundle is in a grounded steel well set into the work table).

b. Place head of primer in safety chamber. (Spring loaded shutter closes chamber automatically.)

c. Untwist primer leads and connect them to "nest" (test set terminals).

d. Reject or accept on basis of meter reading.

e. Remove primer leads from terminals and short by twisting.

f. Remove primer head from safety chamber.

g. (1) If rejected, place primer in disposal box, or

(2) If accepted, place primer in ready box.

As the operator was performing g(2), the primer fired. The operator suffered lacerations and primer case embedment along the right hand and arm. The work enclosure prevented any injury to the rest of the body.

5. 8 October 1953. At the same plant at a different station of the resistance checking line, another explosion occurred involving the same type of primer but with another operator. The exact time of the occurrence in relation to the operational cycle is not known. It did occur at some point between step b and step f since the explosion occurred inside the safety chamber, wedging the lid so tightly that the chamber could be opened only by disassembly. It is almost certain, from statements of the operator and witnesses, that the accident occurred at step c. The safety chamber,

which was made according to the drawings called for by Test Set Mk 162 Mod. 1, was not totally effective although it did prevent serious injury. The operator received three slight cuts on one finger. A suggestion was made that an immediate solution to the missile problem could be achieved by relocating the "nest" terminals to a point that would reduce the time the fingers would be in the missile area. This is, of course, an expedient until the chamber design can be corrected.

ENVIRONMENT OF 1 OCTOBER AND 8 OCTOBER ACCIDENTS

6. In view of the available knowledge about the Mk 124 primer, it is extremely unlikely that any mechanical disturbance it could have received during the handling operation could have fired the primer in either instance. As will be explained later on in this report, this primer is very sensitive to static electricity even though the primer leads may be shorted together. Even so, it would be difficult to conceive of the primer being fired by static electricity if the operators had been adequately grounded. With this in mind, a detailed analysis of the electrical environment and relevant factors surrounding the 1 October accident was made. This analysis was complicated by the fact that extensive modifications on much of the existing setup had been made before the visits to the plant by the NOL representatives. Nonetheless, a reliable reconstruction appears to have been made concerning the important aspects of the problem and will be detailed in the following paragraphs.

7. The primer handling operations at this plant are part of a high volume type production line. Many of the other operations on the line use electrical motors and solenoids whose operations involve transient high power demands on the distribution system. This should lead to generation of wide band electro-magnetic disturbances generally classified as electrical noise or "static". Such disturbances can be transmitted (depending on frequency) both by radiation and along power lines. It is possible that sufficient power could be absorbed by an electric primer by antenna action of the leads. Depending on the frequency of the power signal, it is possible that firing might occur under varying primer lead conditions. With the leads unshorted and extended like TV "rabbit-ears", it might be most sensitive at a frequency quite different from that with the leads shorted together but spread into a loop. The attachment of the leads to firing lines could make a major change in the frequency sensitivity relationship.

NAVORD Report 3670

8. In order to determine if electro-magnetic disturbances might have been a major factor in either the 1 October or the 8 October accident, an attempt was made to make a survey of the electrical noise on 21 and 22 October by means of a Tektronix 513-D CRO during normal working hours. (This survey was made both with capacitive coupling and closed loop connection to a high impedance input. Frequencies from low audio to intermediate RF were detected.) It was not possible to make a comprehensive quantitative analysis, however. Those frequencies detected did not exceed a few millivolts-- a potential level two or three orders of magnitude less than the level at which some chance of firing such primers exists. There was certainly not a "radio silence." Best practice would suggest that there should be better electrical isolation in the areas requiring handling of primers prior to their installation in the end device.

9. The entire operation is carried out in an enclosure of the type shown in Figure 1. This enclosure, known as a "doghouse," has a steel floor and framework. The operator is grounded by a coil spring type wrist bracelet of the type shown in Figure 2. Dangling grounding chains of the bathtub stopper chain type were spaced about every quarter of an inch across the ports into which the operator inserted her hands. It was found by measurement with an electrostatic voltmeter that these grounding chains were in some instances ineffective against static potentials generated by an operator. At the time of the accident it is probable that the doghouses were not connected to the driven ground provided for the purpose. The doghouses did provide a mechanical support for the fluorescent fixtures which are, in turn, referenced to ground via the electrical conduit system. It is not likely that the resistance of the ground return of the doghouses could have exceeded 10 ohms.

10. The ready box in which the 1 October explosion occurred was resting on a steel well which was set into and electrically in contact with the floor of the doghouse. The resistance from a similar ready box, placed in about the same position to the point of attachment of the grounding wire to the wrist bracelet was less than 5 ohms. It was noticed that the resistance between two diametrically opposed points on the bracelet was about 10 ohms. This is due to the resistivity of the stainless steel used in making the watch band. However a 15 ohm ground return resistance can be considered a short circuit in comparison with ordinary body skin contact resistance.

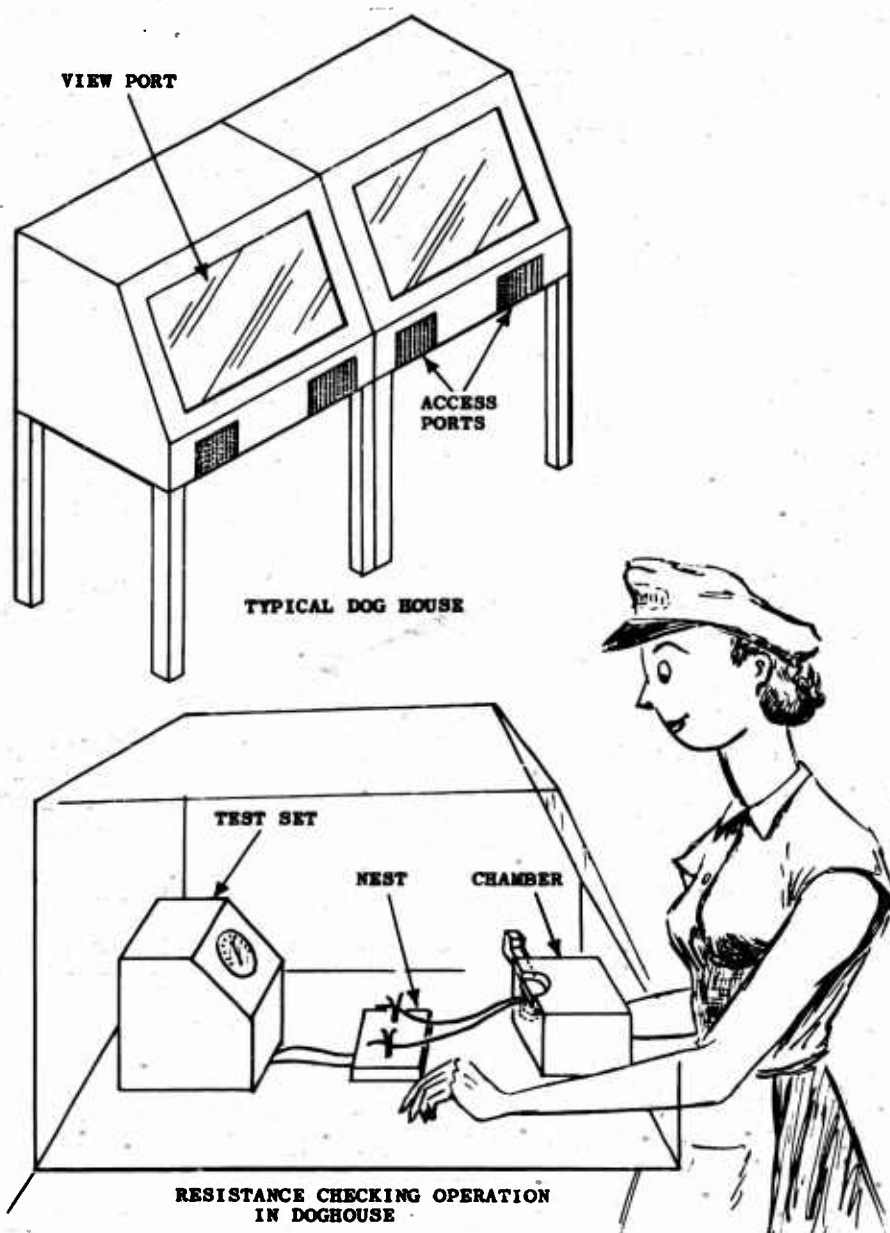
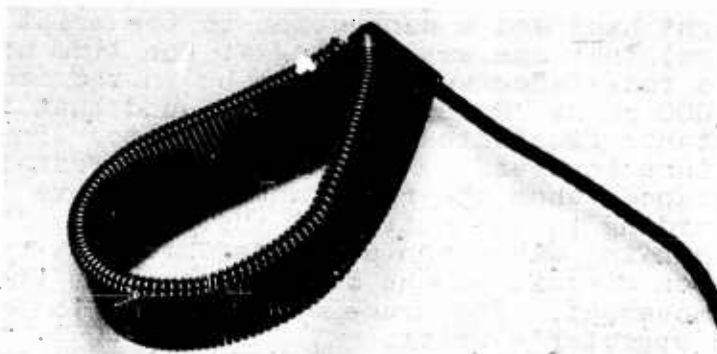
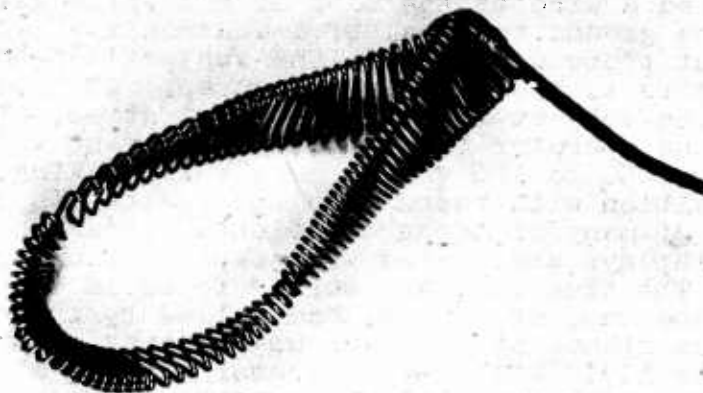

FIG.1 OPERATION ENVIRONMENT DURING 1 OCT AND 8 OCT ACCIDENTS



WRISTLET WORN BY OPERATOR DURING 1 OCT ACCIDENT



WRISTLET WORN BY OPERATOR DURING 8 OCT. ACCIDENT.

FIG. 2 WRISTLETS WORN DURING 1 OCT AND 8 OCT ACCIDENTS

EXPLANATION OF 1 OCTOBER ACCIDENT

11. The operator's body resistance was measured with a battery powered volt-ohm-milliammeter between a test lead held in her right hand and a connection to the wrist band (on her left arm) that she was wearing at the time of the accident. This resistance was found to be in the order of 50,000 to 100,000 ohms. However, it was found that this value of resistance fluctuated when the operator simulated the normal motions involved in checking primer resistance. There were instances when the resistance went above 5 or 10 megohms according to the motion of the needle. It is likely that grounding was momentarily defeated but not indicated as open circuit on the meter because of the inertia of the needle movement. The bracelet was found to fit rather loosely on the operator's wrist.

12. An attempt was made at this Laboratory to show that it is possible, on a dynamic basis, to generate electrical potentials on the body even though a grounding strap was worn. This attempt was made on a qualitative basis but is indicative of the fact that it is possible to generate dynamic "static" potentials. A sheet of lucite was placed on a concrete floor. The subject, standing on the lucite sheet, connected a wire to the band of his wrist watch. The wire led to the ground terminal of a Tektronix 513-D CRO. The scope input probe was held in the subject's hand, usually the hand opposite to the wrist watch strap. Without the grounding of the subject through the wrist strap, it was possible for the operator to generate transient voltages in the order of 50 to 100 volts, merely by making sudden changes of position with respect to the lucite floor plate. The waveshape of many of these transients resembled the exponential displays associated with capacitor charging and discharging. The time constant seemed to be in the millisecond range and was, of course, controlled by the capacity and leakage resistance of the various elements of the electrical assembly. With the operator wearing a grounded, loosely fitting watch band, it was possible to generate similar transient voltages. The amplitude of the transients was usually about one order of magnitude smaller.

13. Under a combination of environmental factors conducive to this effect, it is apparently possible to generate transient voltages on the human body even though the wrist or ankle is surrounded by some form of grounded conductor. This statement is borne out specifically by an instance at the NOP, Crane, Indiana. By use of a "STATICATOR" -- an electronic instrument which senses potential fields -- it

NAVORD Report 3670

was demonstrated that one operator was repeatedly tripping the alarm system even though he had a grounded copper wire wrapped around his wrist.

14. By an application of electrical theory, it would seem that the presence of a conductor closely surrounding the body or a portion thereof, but not in contact with the body, could aggravate the danger. Such an electrical system could augment the electrostatic capacity of the body and therefore make it possible to accumulate a greater electrical charge at the same potential and therefore more energy. Depending on the magnitudes of the controlling parameters, this could be a significant effect and could, if the explosive device is energy discriminatory under the given conditions, increase the likelihood of firing.

15. The ready box in which the 1 October explosion occurred, and the remaining unexploded primers are shown in Figure 3. Inspection of the ready box indicates that the center of the explosion was about 1/2 inch above the bottom of the box and close to the side wall. The operator was in the habit of placing the accepted primer in the ready box by means of the twisted leads. Apparently the head of the primer swung toward the operator as it descended into the box and touched the near side of the box before it had yet reached bottom. Apparently at the moment of contact of the primer to the box, an electrical discharge occurred between the operator and reference ground through the primer leads to case and from the case to the grounded ready box. That the leads were probably twisted together would not make any less likely this reconstruction of the accident. (Ref. a)

EXPLANATION OF 8 OCTOBER ACCIDENT

16. Much less detailed information is available concerning the circumstances of the 8 October accident. The operator was in the habit of wearing her grounding band on her upper arm. That the grounding band was stretched (probably for comfort) is known. How well it maintained contact is not known. Since the accident occurred while the primer was in the safety chamber, it is possible that the test circuitry may have in some way contributed to the firing. The fact that the operator's finger was in the blast area indicates that the hand may have been in some way involved with the primer leads.

Ref. a. NAVORD Report 1762 - Kabik & Ayres

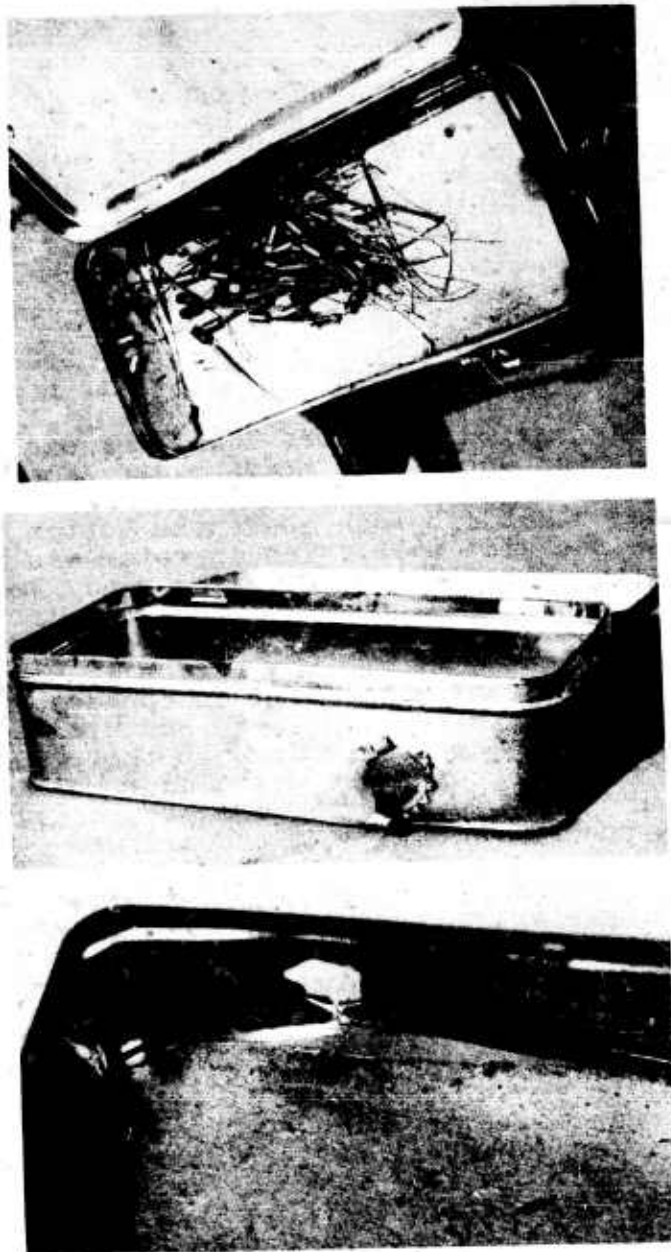

FIG. 3 PHOTOGRAPHS OF THE READY BOX
INVOLVED IN THE 1 OCT ACCIDENT

NAWORD Report 3670

17. Inspection of the test circuitry revealed some interesting facts. The circuit had been constructed in agreement with the specifications for Test Set Mk 162 Mod 1. The wiring in the instrument box, the leads to the "nest", and the nest contacts were well insulated from ground. This means that the entire circuit would have a definite capacitance to ground. The magnitude of this capacitance was not measured but was estimated to exceed 50 micro-microfarads and could perhaps be an order of magnitude greater. Another aspect of this design was noted; the power was on continuously in the test circuit. Thus the meter needle began to move to its final reading as soon as the primer connection to the nest was completed. This was done to speed up testing and to give economy of motion. The insertion of one or two hand operated "read-out" switches would slow up the operation somewhat but should not make much difference in the total cycle time simply because of the inherent sluggishness of other parts of the cycle.

18. The lack of grounding of the circuit of the test set is inherently a dangerous condition. As was pointed out in reference a., this particular arrangement could store enough energy on the insulated circuit to fire a primer. The energy thus stored can be derived at some time previous to a primer handling cycle and is thus a latent source of trouble. Since there are a number of quite different ways in which this arrangement can act adversely, it is possible to conjecture a number of different circumstances attributable to the isolated circuit, whereby the 8 October accident could have happened. In order to eliminate the isolated circuits, it was decided to ground the instrument circuits and cabinets of all the test sets on the line. This led to a new effect. Because of the peculiarities of the circuit, an operator touching the steel floor of the work enclosure and the ungrounded spring brass terminal of the nest, could cause the meter needle to deflect from zero, even with the test set power turned off. This was due to the galvanic action between the steel and brass using skin moisture as the electrolyte and the microammeter as the return path. However, the current that resulted from the galvanic potential was quite small, less than that which could flow through the primer from the test set. In any case, the maximum e.m.f. derivable from a single cell is well below the presently known lowest voltage at which a primer of this type has been fired.

19. It is not good practice to have an electrical test circuit energized at the time an electro-explosive unit is connected to it. True, the basis of the design of the

test circuit is that the maximum current put-through is still safe by a large margin. However, it is normally possible to devise some method, by mechanical interlock or by operational requirement, whereby the power to the primer is applied only after the operator is completely protected. In the present instance, it seems that a good modification of the circuit, as in Figure 4, might be to install two push button, double throw switches, one for each hand, at points that would move the operator's hands well away from the safety chamber and from the primer containers. By this switching arrangement it would insure not only that the

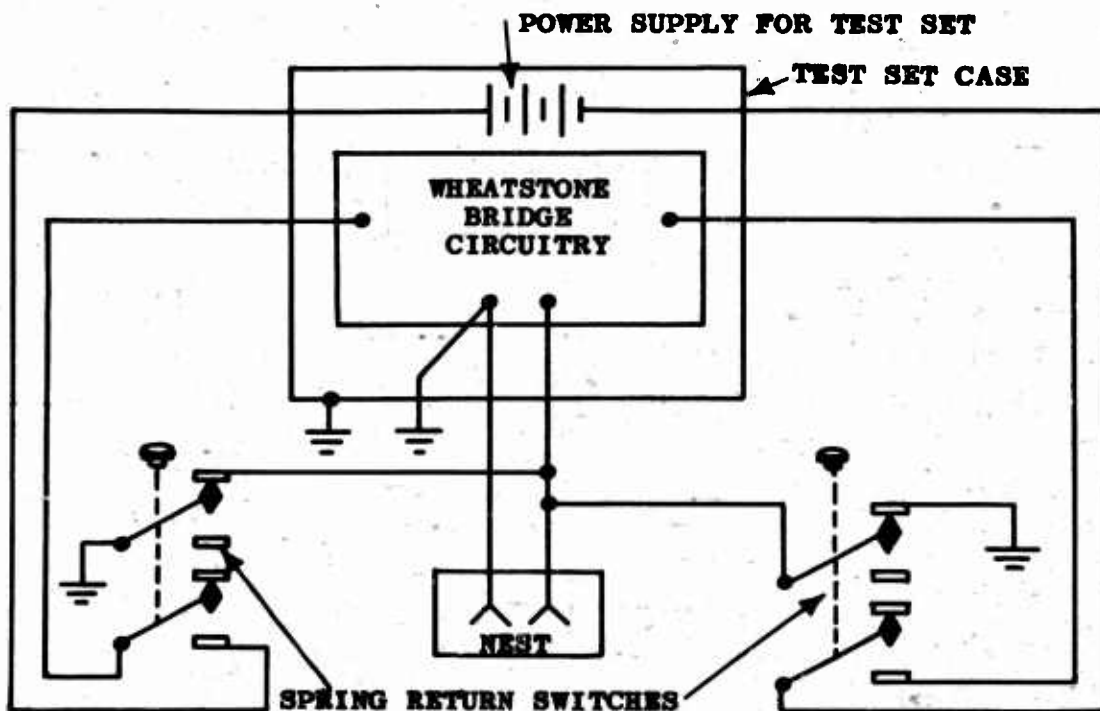

FIG. 4 SUGGESTED ARRANGEMENT OF TEST SET MK 162 MOD 1 CIRCUIT

power to the test circuit would not be turned on till both hands are out of harm's way, but also that both leads would be shorted to ground. This would eliminate the galvanic effect mentioned in the previous paragraph, in addition to giving electrical grounding of the connected primer except during actual testing.

20. It is here emphasized that Plant A had met its responsibilities in regard to the construction and use of the test set. It was made according to specifications. Furthermore,

NAVORD Report 3670

after the 8 October accident, all of the test sets were fully inspected by competent plant personnel and were found to be not defective.

21. While it is not possible to state the most probable cause of this accident, the following possibilities appear equally likely.

- a. Electrical energy stored on test circuit wiring
- b. Energy transmitted from operator through primer to charge the test circuit wiring.
- c. Energy transmitted from operator through primer to ground.

In order for either b. or c. to have been the cause, it would have been necessary that the operator grounding band had been defeated at the instant of the explosion. For a. to have been the cause, the defeat of the arm band, or its complete absence could have occurred prior to the accident. In any case, the mode of initiation could have been leads-to-case, lead-to-case, or lead-to-lead.

20 NOVEMBER ACCIDENT

22. On 20 November 1953 at Plant B, an accident occurred involving the completed assemblies supplied by Plant A. These assemblies are roughly cylindrical in shape, about 1 inch long, and 1-1/2 inches in diameter. They contain various mechanisms which relate to the circuitry leading to the primer as well as housing the primer.

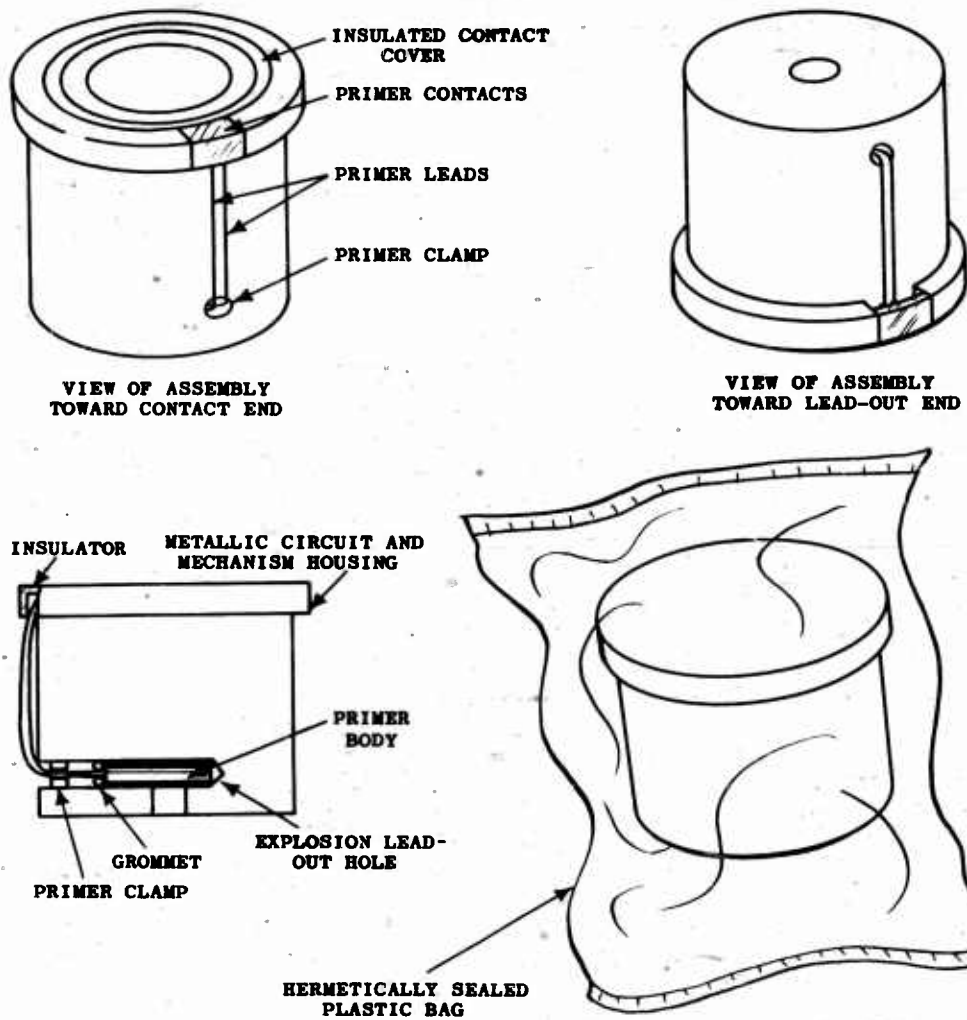

FIG. 5 VIEWS OF THE ASSEMBLY AND POLYTHENE BAG OF THE TYPE THAT FIGURED IN THE 20 NOV AND 2 DEC ACCIDENTS

Among other things, the circuitry provides an electrical short across the primer leads. The grounding is to the metal frame of the assembly. Figure 5 shows an artist's conception of various views of this assembly demonstrating the salient features pertaining to this and the following accident.

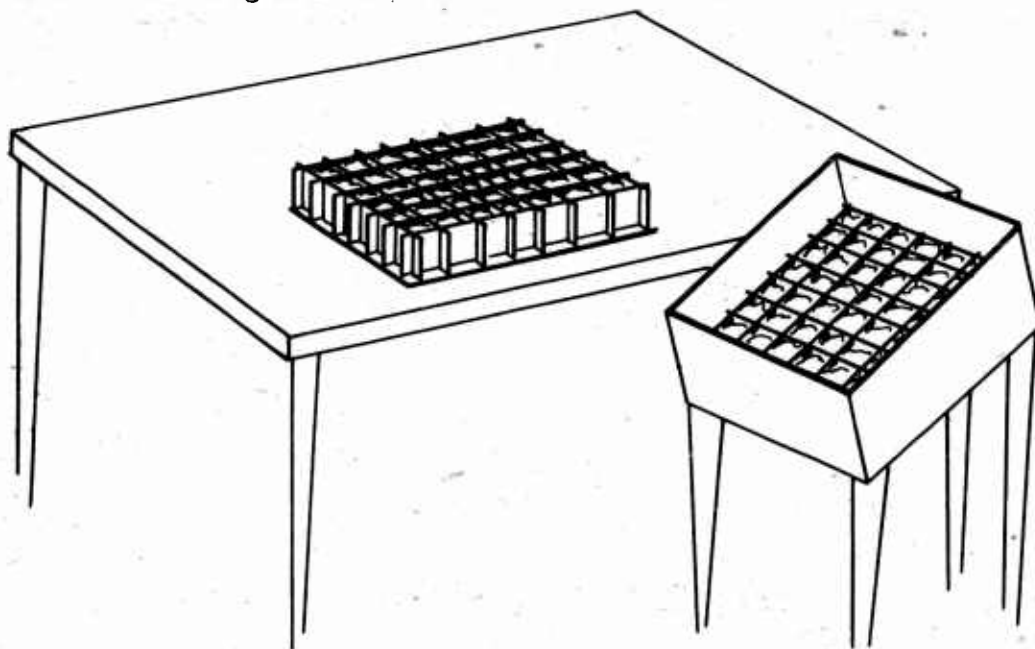

FIG. 6 TABLE ARRANGEMENT PRIOR TO FIRST ACCIDENT AT PLANT B

When these assemblies are completed by Plant A, they are put in heat sealed polythene bags to keep out foreign material and moisture, and then are put into cardboard "egg-crate" type shipping containers, each assembly isolated from the next by a complete surround of cardboard. The first operation in Plant B prior to 20 November in handling these assemblies was to take out a tray of 42 and place it on a felt covered steel bench, as in Figure 6. The next step was to cut open the tops of all the bags and then to remove each assembly from its bag by spilling it out as in Figure 7.

23. As well as the operator can remember, she was involved in the "spilling" process when the primer fired. She received numerous cuts and burns and particle embedment on various portions of the face, embedment just below the left collar bone and some minor cuts and burns on one hand. The sound wave brought about a temporary deafness. Miraculously, she escaped optical injury or cutting of major blood vessels in the neck or forehead.



FIG. 7 REMOVING ASSEMBLY FROM PLASTIC BAG

2 DECEMBER ACCIDENT

24. On 2 December, at the same plant during the same operation, with a different operator, a second accident occurred but under quite different conditions. As a result of the 20 November accident, the felt pad had been removed and a shield built around the work area as in Figure 8.

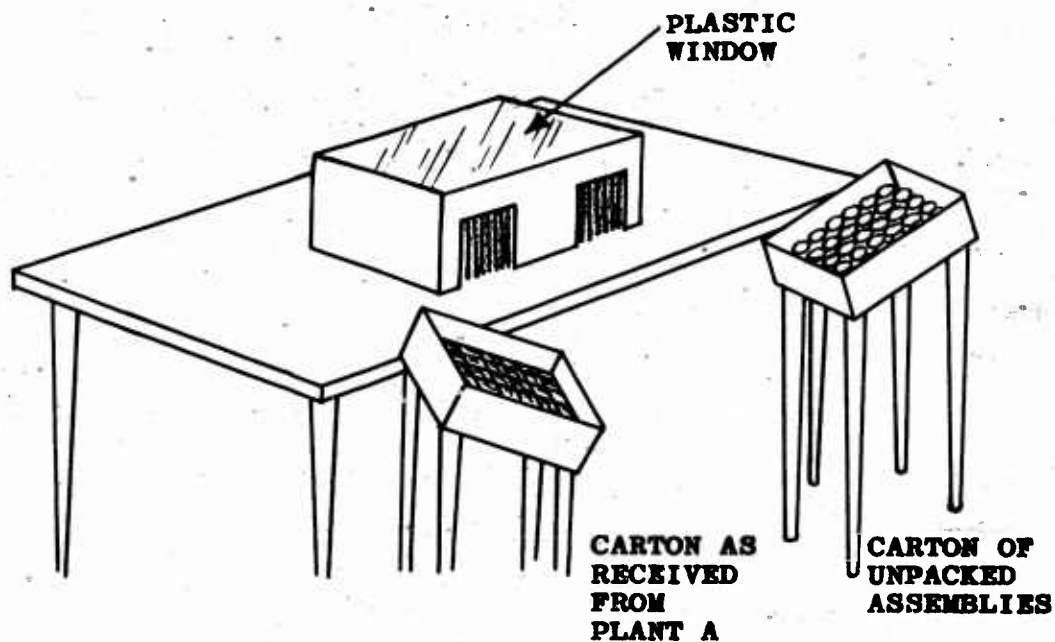

FIG. 8 UNPACKING STATION AT PLANT B ON 2 DEC 1953.

The packaged assemblies were removed singly from the shipping container at the left and set down on the steel table inside the shield. The bag was cut open, the assembly spilled out and then placed with the right hand in the box of unpacked assemblies. The unpacked assemblies are placed touching each other in layers on a cardboard sheet which separates the layers. The box is also cardboard.

25. Although the operator had been instructed to unpack the assemblies one at a time, she picked up three assemblies simply by catching the tops of three bags as they extended above the egg crate divider. This she did in an attempt to speed up her production to keep up with the rest of the line. There is not sufficient evidence to state whether or not the infraction of instructions was a significant factor of the explosion.

NAVORD Report 3670

Either as the operator was setting the three assemblies down, or as she was moving her hand away, one of the primers fired before the bag had been cut open. Her involuntary sudden motions away from the explosion area caused her to scrape the back of her right hand on the enclosure. The location of the assembly at the instant of the explosion can be deduced from the denting of the steel work table surface. The assembly must have been standing with its axis of symmetry vertical and with the lead out hole downwards. The assembly must have been standing very nearly as close to the rear wall of the enclosure as its plastic bag would allow it and no more than a quarter of an inch above the surface of the table. The orientation of the side hole cannot be deduced from the available evidence.

EXPLANATION OF 20 NOVEMBER AND 2 DECEMBER ACCIDENTS

26. A survey of the electrical noise environment was made on 4 December at Plant B similar to the survey made on 21 and 22 October at Plant A. There was good reason to perform this survey since within a few hundred feet of the production line was an installation of transformer test equipment involving high voltage pulsing gear. On the days of the two accidents, 750 kv testing had been under way. Special schedules of similar discharges were set up for the survey. No signals from this source could be detected. The detection level was about 0.1 to 0.5 millivolt. However, the general noise level, derived mostly from machines on the line, was found to be considerably higher than at Plant A with some pulses running as high as 1 volt. It is improbable that radiated energy, tuned to the lead system's resonant frequency, was present in quantity sufficient to fire the primer. To reduce such a probability to a negligible factor, it is possible to shield the working areas completely in the manner used to provide signal free enclosures for set alignment operations on a radio receiver manufacturing production line.

27. From the nature of the injuries, resulting from the 20 November accident, it would seem that the lead out hole of the assembly was pointed directly at the operator's face, and the side hole and therefore the primer lead wires toward the operator's hand. Tests were made at Plant B on 4 December to determine if a detectable charge could form on an assembly when spilled from the plastic bag. An assembly was allowed to slide out of its bag on to an insulator and into contact with the input of an electrostatic voltmeter. Potentials to ground of 250 to 300 volts were frequently observed. The input capacity of the electrostatic voltmeter was about

75 $\mu\mu\text{fd}$. Thus energies in the order of 25 to 100 ergs were readily generated by this mechanism. Before the assembly came in contact with the electrostatic voltmeter its capacitance was less than 10 $\mu\mu\text{fd}$. The initial potential of the charged assembly would have been on occasion over two thousand volts. From the inference that the primer leads were close to the operator's hand, it is reasonable to believe that a charge accumulated on the assembly and then discharged through the primer leads to the operator. In order for this to happen for either lead-to-lead firing or leads-to-case firing either the protective short would have to have been defeated within the assembly itself or else microwave transmission line type phenomena would have to occur wherein on a transient basis a potential difference can exist along the length of a metallic conductor.

28. An inspection of the shorting circuit mechanism was made. Certain contact members which are normally held firmly in place were found to slide. Personnel of Plant B had found that by shaking the assembly it was possible to obtain occasional readings on a volt-ohm-milliammeter of 10 ohms. It is probable that the momentary maximum values of resistance could have been much greater than 10 ohms. Whether this condition of the shorting circuit was brought about by the primer blast or whether it existed before is not known. Subsequently other assemblies of the same lot were tested at the Naval Ordnance Laboratory. A primer was connected by extra leads to the two terminal points to which would be connected the primer installed in the assembly. These two points are normally electrically connected by the internal shorting mechanism. An external battery and resistor were connected in series with the terminal pair. With this arrangement, any momentary opening of the short circuit, even as short a time as a few microseconds, should cause the primer to fire. In one of the assemblies tested, a tap with a light hammer defeated the short. In another instance, the short was defeated by the slight disturbance created by picking up the assembly.

29. In attempting to find a basis for explaining the 2 December accident it is first necessary to find out how the charge could have been formed. The act of removing the bagged assembly from the egg-crate dividers could generate a static charge on the outer surface of the plastic bag and an equivalent opposite charge on the cardboard. The energy flow associated with firing the primer would not necessarily require a dielectric breakdown of the plastic bag, although such an action is most likely. By a change in physical orientation of the various conductors and insulators it is possible, by capacitive induction, that

there would be sufficient displacement currents to fire the primer. Another hypothesis is tenable. If the original charge were to act as if it were on the assembly, it could discharge through the primer lead wires to the rear wall of the enclosure, or to an adjacent assembly, or to the operator's hand. Once a bound charge is accumulated on the outer surface of the bag, the assembly inside the bag would act as a conductor in such a way that a flow of energy to some point on the assembly would be distributed to attempt to neutralize the field due to the bound charges. Figure 9 is an attempt to portray this action. It is barely possible that the charge could have dissipated through the leads to case and then from the case to the work table top through the explosion lead-out hole. If the charge were to have been collected on something other than the assembly in which the explosion occurred -- for instance, the operator or an adjacent assembly -- the discharge could take place through the assembly and primer wiring to the grounding enclosure or to another assembly.

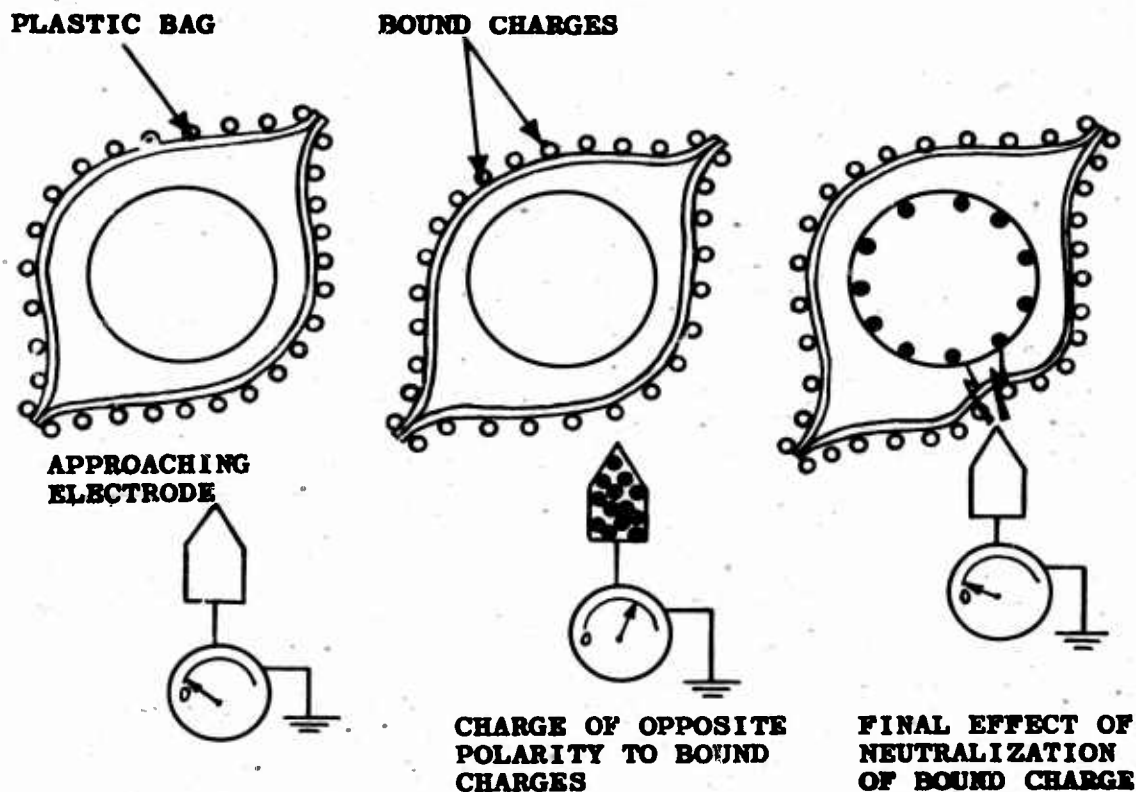

FIG. 9 EXPLANATION OF CHARGING ACTION THROUGH PLASTIC BAG

30. In both the 20 November and 2 December accidents, the fact that the plastic bag is a prolific generator of static or friction electricity provides the most probable basis by far for explanation. That in the first case, the operator was working without either shield or safety glasses is not considered to be a condemnation of company B since the entire philosophy and design intent of the assembly was that it should be safe to handle. However, as was demonstrated on 20 November, it is best policy to provide adequate protection so that the operator cannot be hurt if the device should explode -- EVEN THOUGH IT "CAN'T EXPLODE".

31. The fact that the shorting mechanism within the assembly is far from perfect is unfortunate. An occasional defeat of the shorting feature simultaneous with the transfer of an electrical charge through the critical paths is not difficult to believe since both actions result from motion of the assembly with respect to its environment. However a defeat of the shorting feature is not necessary to allow an explanation of the 20 November and 2 December accidents. As will be brought out in paragraph 45, laboratory tests have shown that the primer could be fired even if the shorting feature were intact at the instant of energy transfer. The fact that the shorting feature can be defeated by an adverse mechanical environment would certainly make the device more prone to this form of trouble and may very well jeopardize the inherent design safety of the device.

27 FEBRUARY ACCIDENT

32. On 27 February, 1953 an accident occurred at Plant C with a Mk 121 primer installed in an assembly of type similar to the one associated with the 20 November and 2 December accidents previously described. The Mk 121 primer is a carbon bridge primer physically larger than but similar to the Mk 124, and with the same type of electrical sensitivity. The assembly involved in this accident differs considerably in detail from that previously described. In particular, the electrical short across the primer is obtained by a spin switch and by a soldered wire which is sheared at a time appropriate to the fuze action. The particular assembly involved in the accident was to be reworked: that is, having been rejected, it was to be partially disassembled and repaired. The operator removed the assembly from a shield enclosure, and without any form of personal protection, proceeded to unsolder the shorting wire. He was using a quick heating, trigger action transformer type of soldering gun. Apparently he had succeeded in detaching part of the shorting circuit wire,

and had then released the soldering gun trigger while the gun tip was in contact with the post to which the primer lead was still fastened. The primer fired. Since the operator was holding the assembly between his left thumb and forefinger with the thumb over the side port leading to the primer, he suffered loss of the nail and a portion of the first joint of the thumb.

33. Tests subsequently performed at the Naval Ordnance Laboratory indicated that peak potentials could be generated across a primer bridge of 80 to 100 volts if one unshorted lead of the primer is in contact with the gun tip and the other lead grounded. Figure 10 shows the electrical physical arrangement and the circuit analog. It is not as likely that the voltage pulse was derived from magnetic coupling as that it resulted from the capacitance existing between the windings. The association of the pulse with trigger action turning the gun either on or off can be explained on the basis of inductive "kick". Due to the induction of the primary winding, the opening or closing of power to the winding usually causes a momentary peak voltage to appear across the winding. This voltage peak may be considerably greater than the normal supply voltage. As part of the test at the laboratory, six Mk 121 primers were fired

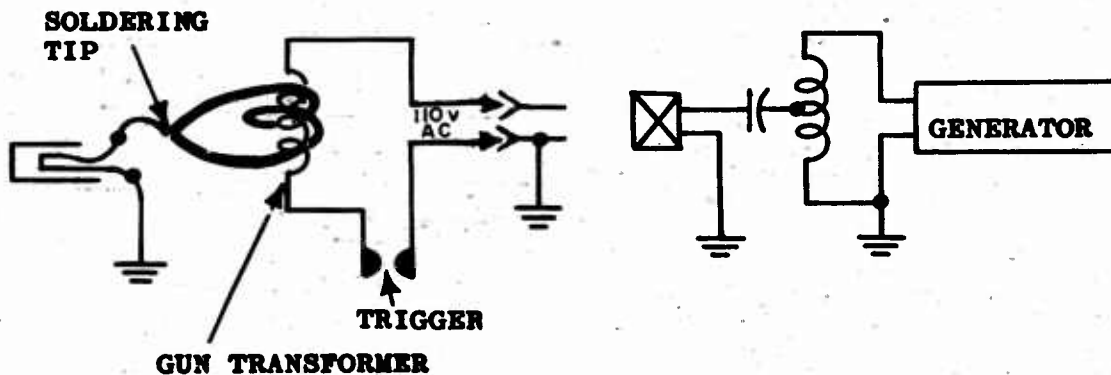

FIG. 10 SYMBOLIC REPRESENTATION AND CIRCUIT ANALYSIS OF THE ACTION OF THE WELLER GUN ON MK 121 PRIMER

in the arrangement shown in Figure 10. It was not possible to fire the Mk 121 primer when the leads were twisted together nor was it possible to fire a Mk 114 primer

(wire bridge type) either with the leads shorted or unshorted. The possibility of firing the primer by heat from the soldering gun has been ruled out in this accident.

34. In reviewing this accident, it is possible to see that two fundamental rules had not been followed. First, the explosive operation had not been carried out in an adequately shielded area. Second, an improper soldering iron had been used. In working with electro-explosive devices, it is imperative that a heating element type soldering iron with grounded tip and element insulated from the tip should be used. Even better would be a grounded iron which does not have any heating element but is kept at the proper temperature by resting in a separate heater. In the case of an iron with a heating element, it should be designed to keep to a minimum the capacitive and magnetic coupled fields due to the wiring contained within the iron. An iron having a thermostat might be dangerous due to switching surges during operation of the thermostat.

ACCIDENT AT FRANKLIN INSTITUTE

35. During August of 1952, an accident occurred at the Franklin Institute in Philadelphia, Pennsylvania with a carbon bridge detonator. The institute is primarily engaged in developing techniques for test firing large numbers of detonators. Their present handling methods are to be commended and are well worth study by other groups who must handle carbon bridge devices even though some of the particular approaches are especially well suited to firing and may not be readily adapted to assembly problems.

36. One of the features worthy of particular note is the present firing chamber. An inner housing surrounds the actual blast. This housing locates the optical system for timing by flash. On the housing is mounted the terminal assembly. Across the face of the housing is a narrow opening between two pieces of plastic. The head of the detonator is slipped behind the plastic pieces with the lead wires coming forward through the slot. The time between removal of the primer from a Faraday-shield type ready box to the instant when the head of the detonator is behind the slot is about 6 seconds. This is the time the operator is exposed to a direct blast hazard. It is possible that with elaborate carrying devices and handling fixtures, this exposure time could be reduced. However, the grounding arrangements presently used made the operation adequately safe, provided the operator is sufficiently grounded. After the detonator head is in position behind

the slot, the leads, still shorted by being twisted together, are slipped into a slotted terminal assembly. An outer chamber totally encloses the inner housing assembly by the closing of a door. The closing and latching of the door automatically shears off the twisted portion of the leads, connects the primer electrically to the testing system, and electrically removes the grounded short across the test terminals.

37. At the time of the accident, the terminal system was not the same in certain aspects. The primer leads, while still twisted, were slipped into a different form of a slotted terminal assembly. These terminals were electrically shorted, but apparently not grounded. The leads were clipped off with a grounded, hand-held cutting tool. The operator was grounded to the conductive floor by a dangling ankle strap. The accident is thought to have occurred at the instant of cutting off of the twisted lead wires. The most credible reconstruction of this accident requires a charge to have been accumulated on the ungrounded circuitry and an actuation through the bridge to the grounded cutters.

THEORY, FACT, AND RUMOR

38. Lead wire carbon bridge primers and detonators are usually shipped in moisture-vapor proof barrier packages. Basically, such packages have been metal foil envelopes bonded to an outer protective shell of paper, fiber, or fabric. The foil envelope inner surface has a continuous thermoplastic coating by means of which a moisture-vapor proof seal of the envelope can be achieved. The primers are put in these envelopes with the leads twisted together. Mk 124 primers are usually packed in bundles of 25 or 50. By written instructions, it is required that the foil envelope be perforated with a grounded metal stylus before opening. In the light of the 20 November and 2 December accidents, pre-existing doubts concerning this packaging method were intensified. A number of alternative mechanisms could be suggested whereby the act of removing or replacing a primer could generate sufficient static potentials to fire the primer. On 14 December 1953, a verbal statement was received of an accident which had occurred some time past at the primer manufacturing plant which supplies Plant A. It was reported that the accident occurred during the insertion of a detonator (probably of the T18 type) into one of the pockets of the multi-pocket foil envelope. It was further reported that the leads were electrically shorted by being twisted together. Other instances of firing of primers at improper times are known

NAVORD Report 3670

with varying knowledge available concerning the circumstances surrounding such instances.

OUTLOOK

39. The accidents reported in the previous paragraphs might appear to be the basis for a severe indictment of the carbon bridge type electro explosive device. The explanations of these accidents have been, with ranging degrees of credibility, of an electrical nature. These explanations are based on the assumption that there has been no significant possibility of some chemical or mechanical phenomena entering in.

40. Using the assumption of electrical causation as a working hypothesis, it is conceivable that there is no way of handling these devices without an occasional unwarranted initiation. Even if such should prove to be the case, it is probable that the demand for them would require that they be used anyway. To handle these primers safely (even though some were due to explode no matter how carefully treated) could still be accomplished. However, the present indications are that it is possible to handle these primers with direct operator physical contact by the application of a few fundamental principles.

MODES OF INITIATION

41. An understanding of the various ways in which electrical energy can induce an explosion will provide a logical basis for the application of the fundamental principles of safe handling. Figure 11 is a schematic representation of a carbon bridge electro-explosive device. In normal use, the primer is fired by applying electrical energy of suitable properties to the leads from which has been removed the external electrical short.

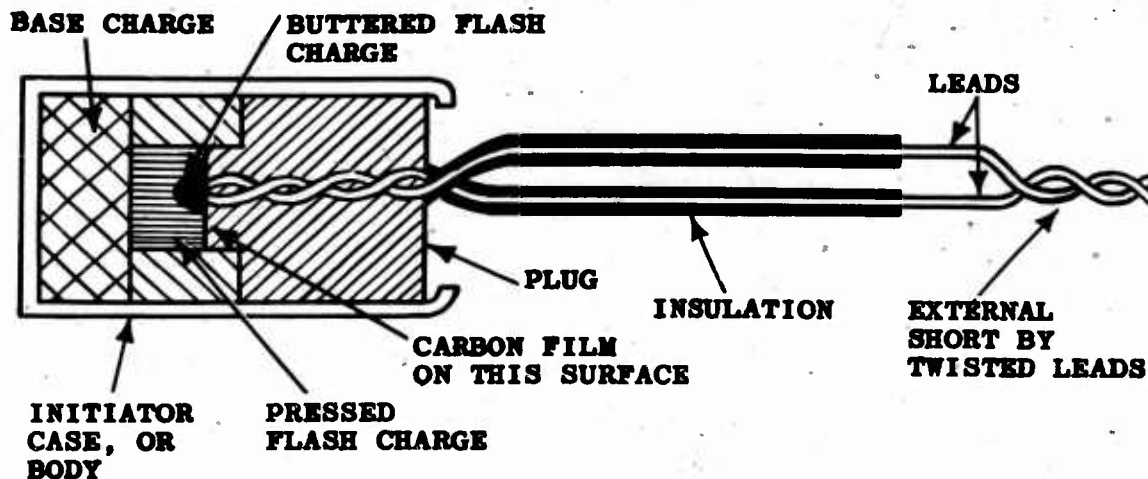

FIG. 11 PHYSICAL ARRANGEMENT OF A CARBON BRIDGE INITIATOR

The circuit is completed through the carbon film on the face of the plug. The electrical energy is dissipated in the carbon film, heating it enough to cause ignition of the flash charge.

42. There are other modes by which electrical energy can be dissipated in the unit in a manner to bring about initiation. Up to potential differences from 300 to 400 volts, the resistance measured between the case and the lead system is in most designs greater than 50 megohms. At some high voltage, failure of the dielectric must occur. Often the failure is accompanied by the initiation of the primer. In such cases, the explosive is likely to be involved in the dielectric failure. At the present time the exact mechanisms whereby the explosive enters into the dielectric failure are not known but well-founded theories do exist.

43. The leads and therefore the carbon film would be at one potential. When the potential gradient between the film and the closest metal parts, other than the leads, is sufficiently great a spark-over can occur. The spark-over, if through the explosive, can initiate the explosive directly, or the passage of energy through the carbon film to the discharge point can heat up the carbon film until the explosive is set off by a hot spot in the carbon film. It is possible to hypothesize another way of initiating an explosive, viz., by mechanically stressing the explosives

crystals by a high potential gradient. It would seem that when the stress is sufficiently great, the mechanical strength of the crystal will be exceeded leading to a fracture or breaking of the crystal which in turn could initiate the crystal. In such case, the actual current flow might be limited to such effects as displacement currents, dielectric absorption, etc. The actual energy dissipated in the system could be much less than the energy required to make the primer function in its normal mode. It is to be noted that any of the mechanisms cited in this paragraph can function even though the leads are externally shorted. The shorting of the leads will prevent firing of the primer in the normal mode, but is not a reliable preventative against the other firing modes.

44. It has been reported by a Navy contractor and subsequently verified at the Naval Ordnance Laboratory that physical arrangement of the leads makes a marked difference in the sensitivity of the initiators. If instead of being twisted along their length, the center section of the leads are opened into a loop about 2 or 3 inches long and 1 or 2 inches across, with the leads still close together at the plug and still shorted at the outer end, all or nearly all will be initiated by case-to-leads spark discharge. With the leads twisted along their entire length many and perhaps the majority of the primers will spark over externally between the leads and the crimp and do not fire. The loop effect mentioned above indicates a high frequency resonance of the loop being excited by the spark discharge. The exact circuit analogs and mechanisms are not clearly understood. Indications are that the bridge itself enters into the system. What might seem at first a logical counter-measure would be to reduce the bridge sensitivity. The energies that are possible in many handling procedures are so great that an adequate desensitization would probably make the initiator of little value for many of the present applications. Work is being done at this laboratory to obtain a quantitative picture of the various sensitivities and the design parameters controlling these sensitivities. This promises to be a complex problem which may not permit an exact solution.

45. It would seem that to cope with any of the mechanisms listed in the previous paragraphs would require only that the leads and case be electrically shorted together. However, with lead wire devices, it is difficult to short the leads and case together effectively under pulse discharge conditions. To prove this, a setup was made at the Naval Ordnance Laboratory to determine the effectiveness of such

a shorting system. Figure 12 shows the method of mounting the primers for this test. In this case the insulated length of lead was about 4 inches. The bare lead ends were clamped to the brass blocks by two roundhead brass screws. The explosive unit case was set in the drilled hole below

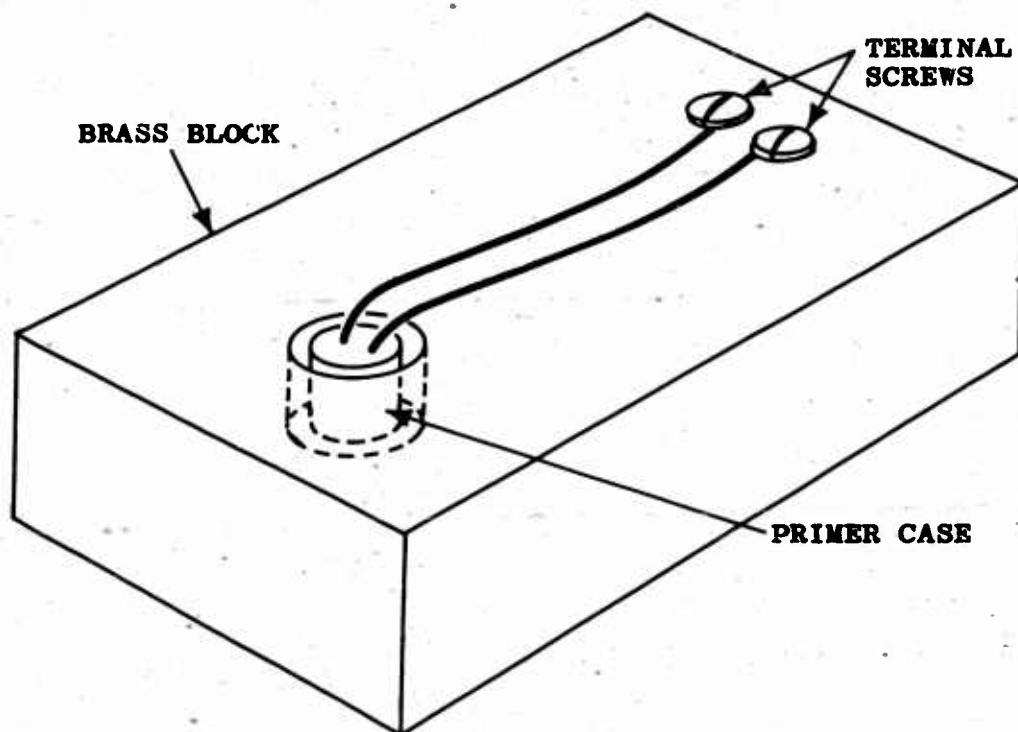

FIG. 12 SETUP TO DEMONSTRATE SENSITIVITY OF INITIATOR WITH GROUNDED CASE AND LEADS TO ENERGY PULSES

the surface of the block. The block was set on a grounded support, as in Figure 13 and a 50 $\mu\mu\text{fd}$ capacitor charged to 10,000 volts was discharged to the center portion of the insulated lead wires through an electrode system. Of 25 primers tested in this setup, one fired. This behavior can be attributed to the fact that under pulse or transient conditions a large potential gradient can be established momentarily on a conductor, the gradient propagating along the conductor in the manner of a micro-wave transmission line. Under this condition the primer initiation might be a normal bridge firing or a lead-to-case breakdown.

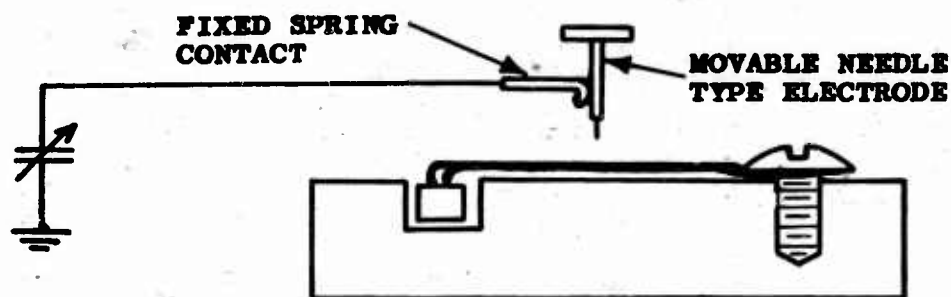

FIG. 13 METHOD OF PULSING SETUP SHOWN IN FIG. 12

THE THEORY AND UTILIZATION OF THE FARADAY SHIELD

46. It now appears that the only way in which this type of electro explosive device can be protected is to surround it completely with a conducting shell with which the unit is in contact. A primer wrapped in aluminum foil falls in this category provided the foil has no anodized or plastic covered surface. Under extreme conditions, of course, the foil wrap could be defeated in that it would not be sufficiently conducting. Such conditions would have to be those used in switch gear testing or its equivalent. Aluminum foil wrap or metal "tote" boxes should be completely effective against high energy micro-wave beams.* The placing of foil wrapped primers in metal carrying boxes, and the boxes in turn inside of metal ammunition cans, thus giving concentric conducting shells, would give much greater electrical protection as well as mechanical isolation. The concept of a totally surrounding conducting shell around the primer affording the necessary protection against external electrical energy is an application of the properties of a "Faraday Electrostatic Shield." A total metallic enclosure about a given volume can be considered to be a Faraday Electrostatic Shield provided all portions of the enclosure are in electrical contact with one another. Any charge arrangement or any field external to the Faraday Shield will have no effect on the enclosed volume. Any electron flow between the shield and any point external to it, will have no effect on the enclosed volume, provided the shield is adequately conducting and provided that the

* At 3000 Mc/sec. the skin depth for copper is about 10^{-3} mm or about .000 04 inches. The skin depth varies as the ratio: specific resistivity.
frequency.

NAWORD Report 3670

electromagnetic phenomena generated by the electron flow are either negligible or else cancelled by the shield action. By two or more concentric Faraday Shields the isolation of the innermost volume becomes highly effective even in the presence of intense electro magnetic fields.

47. A good Faraday Shield is not a 100% guarantee of protection. It can be used improperly. An object within the Faraday Shield can, if not electrically in contact with the shield, assume a potential difference with respect to the shield. The potential difference indicates that an electrical charge has been accumulated on the object. This charge can lead to an electron flow or discharge between the object and the shield structure. Therefore an electroexplosive device can be safely stowed in a Faraday Enclosure only when the leads and case are in electro-mechanical contact with the enclosure structure and when no non-conductors (exclusive of the electro-explosive unit structure) are enclosed.

48. When the electro-explosive device or a vulnerable loaded assembly must be removed from its foil wrap, tote box, or other Faraday device for processing or assembly into the weapon, the explosive unit becomes much more susceptible to initiation by the electrical phenomena under discussion. All faces of the work area enclosure should be conducting. Certain breaches of the enclosure are required -- access ports for the operators' hands, clearance holes for belt feeds. Except for these breaches, and provided there are no non-conductors or energy sources within the enclosure, the enclosure could be considered to be a Faraday Shield. As soon as work is to be performed within the enclosure, the shielding can be defeated. As has been demonstrated in Paragraphs 4-21, the possibility exists of introducing electrical energy using the operator's hand as the conductor. Material moving into the enclosure on an insulated belt could carry an electrical charge into the enclosed volume. (A primer explosion due to this effect has recently been reported by Plant A.)

PROBLEMS AND TECHNIQUES OF GROUNDING

49. Some general principles relating to the design of work enclosures can now be deduced.

a. All structural members, including the windows, must be conducting and must be grounded. There are methods whereby Pyrex, and perhaps other glasses, can be given a permanent, transparent, fused, conductive coating. There

are chemical agents which can be applied to glass and to plastic to give transparent conductive films. These films are probably not permanent, but are readily renewable.

b. Any object introduced into the enclosure must itself be conducting and must be in continuous contact with grounded surfaces. Some objects so introduced, as for instance certain weapon assemblies, may be in part constructed of non-conductors. The risk due to these materials must be considered and either accepted as unavoidable or else minimized by the use of special temporary additions or some other specific adjustment to the problem. If belts are used to carry material through the enclosure, these belts must be conductive and grounded.

c. The most difficult element, that will be introduced into the enclosure is, unfortunately, the operator. There is a wide variability of skin contact resistance from person to person. With low voltage ohmmeter circuits (voltages from 1/2 to 3 volts), resistances from finger tips to arm have been measured on a number of operators ranging from 5,000 ohms to 15 or 20 megohms. The use of a conductive paste such as is used in electrocardiograph work to improve the contact between the wrist and the grounding bracelet, has often been found to reduce the total finger to wrist or skin resistance to about one tenth of the original value. There are a number of instances where little or no reduction of resistance was noted. What the body resistance of the operator would be at higher potentials, such as those normally associated with static electricity, is not known.

50. On a qualitative basis some people consider themselves to be prolific generators of static electricity. Such an evaluation being true, whether it is due to clothing habits or else due to actual physiological differences, is not known. The whole field of body physiology in relation to the problem of static generation and operator grounding is, at least to this author, unknown. It is conceivable that on the basis of some resistance measurement test not yet established, certain people would be found to be satisfactory and others unsatisfactory for performing static-electricity-susceptible operations. It may be that no operator can be adequately grounded.

51. As a best approximation, this laboratory is now recommending the wearing of some such grounding bracelet as the one shown in Figure 14, with the pad worn on the inner surface of the arm since hair is a good insulator. The bracelet should be worn tight enough to cause a depression of the skin all around the pad. The pad should be located

as close as possible to a point at which the body pulse can be felt. If possible, an electrocardiograph paste should be used under the wrist pad. This paste is usually a highly saline material, slightly gritty, which has been found to cause a skin irritation on a minority of the operators after prolonged contact. It is probable that the material loses its efficacy if it dries out. The large contact pad tends to keep the paste wet by inducing perspiration under the pad. Here is another area where physiological aspects of this problem should be studied. L.D. 295547 is the list of drawings of a wrist bracelet similar to the one in Figure 14.

52. An additional method of maintaining operator grounding is gaining acceptance. Grounding is achieved by requiring that the operations inside doghouse type work enclosures be performed by seated employees. The chairs are required to be made entirely of metal. Further all touchable portions of the chairs are required to be unpainted and free of oil, wax, grease, lacquer, corrosion or any other non-conducting films. The chair is grounded either by a braided strap bonded to the system ground or by resting on a conducting floor. The grounding strap may constitute a tripping hazard. For this system to be effective the operators must wear suitable clothing. Consideration should be given to the idea of complete clothing changes as is now standard practice in many explosives plants.

53. Experience has shown that many of the operator grounding techniques now in use are not very reliable unless more-than-usual care is used in their application. Conductive shoes are not effective unless the operator wears conductive socks and unless he stands on a conductive floor. Floor wax, oil, grease, road tar, dirt can cover the sole of the conductive shoe with an insulating film which renders the conductivity feature non-existent. This means that strict rules concerning floor care and permissible areas for wearing of shoes must be established and enforced. Periodic conductivity measurements from the operators to ground must be made. Even with shoes that have had good care and proper use, there is evidence that some may eventually lose their conductivity after a year or so perhaps from repeated flexing or perhaps merely from ageing. In addition to special shoes there are other devices such as booties, dangling ankle straps, and clamp-on arrangements to ground the operator to the floor. The author has insufficient knowledge to evaluate their efficacy or to determine operator reaction to such devices. Any form of conductive footwear will be ineffective if the operator loses contact

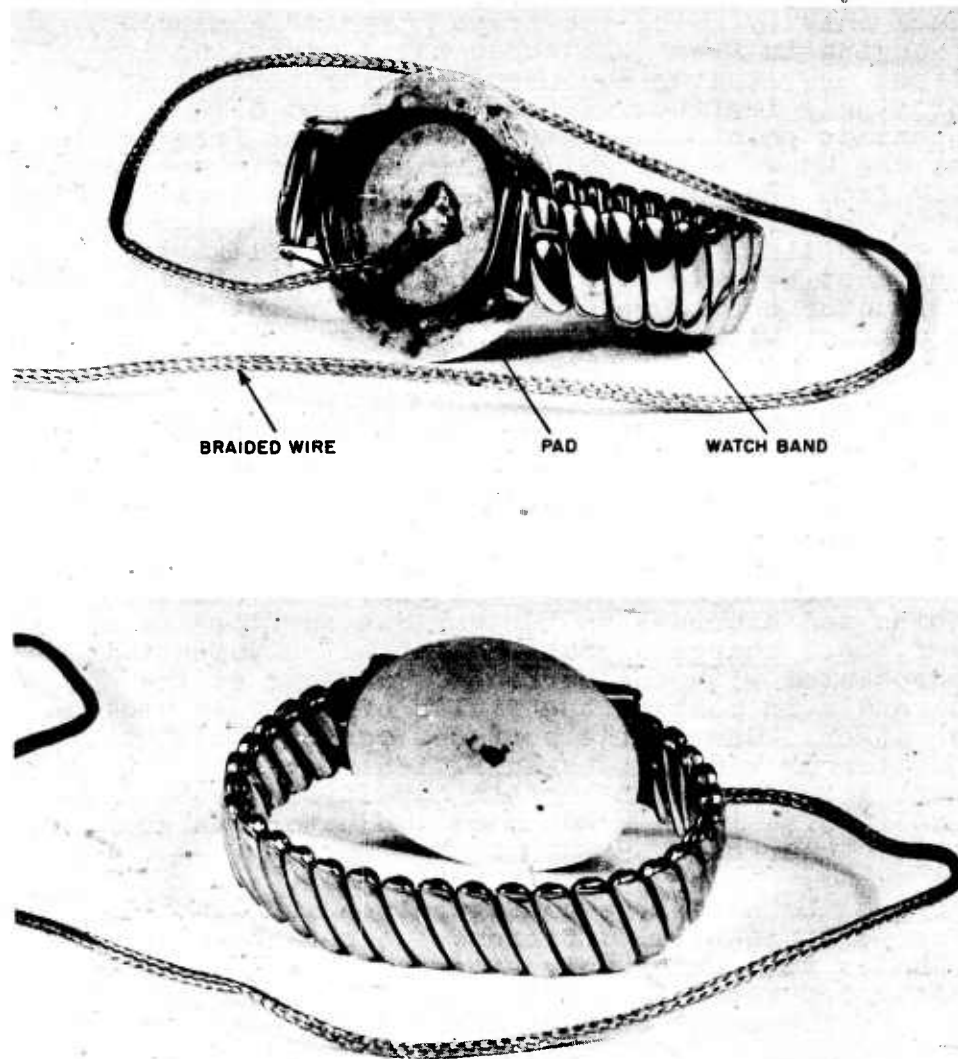

FIG. 14 RECOMMENDED GROUNDING WRIST BRACELET

with the floor by sitting on a stool or by standing on a foot stool or rubber foot-ease pad.

54. A positive grounding of operator or of equipment can be obtained only by using the proper type of conductor. Chains, hanging in front of access ports, dangling from ankle clips, or linking equipment or operators to ground are surprisingly ineffective. Corrosion and dirt films between contact points insulate the links one from another. Instances are known where gold-plated links did not establish continuity from end to end of the chain. The lack of continuity has been found under high voltage conditions and when the chain links have been in tension. Flexible conductors must be made of continuous elements. Each strand of the conductor should reach from ground point to the point of contact with the element to be grounded.

WAYS IN WHICH STATIC CHARGES CAN BE FORMED

55. It is a characteristic of friction or static electricity that the process of generating a charge is two stage;

a. Two non-conductors, rubbed* against each other, suffer a transfer of electrical charges. The electron deficiencies and excesses on the various surfaces as a result of these charge migrations establish potential fields associated with the surfaces. As long as the surfaces remain in contact the fields effectively neutralize each other. One of the surfaces can be a conductor or semi-conductor provided it is sufficiently isolated from environment ground. Under certain conditions systems involving an insulator and a grounded conductor can generate electrostatic charges.

b. Once a bound charge configuration is established on the surfaces, a potential difference measurable at some distance comes into being only after the surfaces are sufficiently separated from each other. The amount of separation of the bound charges need not be very great -- in some cases only a few hundredths of an inch -- before potential differences of hundreds of volts are established.

* A rubbing action is not always a necessary adjunct to static electrification. A transfer of charge (ions or electrons) is necessary. The transfer in some instances occurs upon the act of bringing the surfaces together.

56. Some of the modes of generation of electric charges by an operator are readily seen. When an operator is isolated from ground, (footwear can be made conductive usually only by special effort) the walking of an operator across the floor can generate large potential charges on the operator. The friction of most fabrics against furniture or other objects is a prolific static generator. Apparently cotton and perhaps linen are not offenders on this score. The potentials associated with static electricity can be amazingly high. Potentials as high as 20KV have been measured and as high as 30 KV should be possible.

57. There are other methods by which an ungrounded operator can accumulate a charge. One could be picked up by an ungrounded operator from some object not at ground potential. Usually this object would be a non-conductor or an isolated conductor which had previously become charged. This object might be a conductor connected to a steady source of energy such as a battery. If the transfer of energy to the operator were at a low enough rate or to certain contacts on the body, the operator could accumulate this charge without feeling a "shock" and therefore have no physiological warning.

58. In addition to the accumulation of a charge by friction and by transfer, a charge can be formed by induction. The operator need not touch a bound charge but instead approach fairly closely to become in turn charged. As in Figure 15, electrons will move toward or away from the portion of the body closest to the bound charge in an attempt to neutralize the field of the bound charge. The displacement of electrons within the operator's body will cause a charge distribution to form on portions of the body farther away from the bound charge. This distribution will be of the same polarity as that of the bound charge.

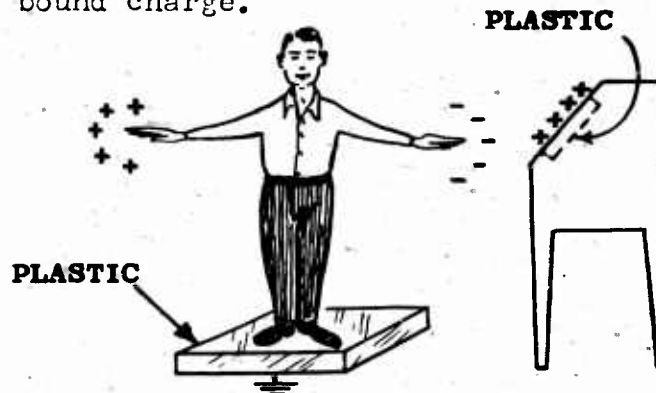

FIG. 15 CAPACITIVE INDUCTION

59. There has been reported an instance of initiation of a carbon bridge primer which can be attributed to capacitive induction. The circumstances were said to be as follows:

The leads of a carbon bridge initiator were attached to a grounded metal rod with the head of the initiator extending beyond the rod. The initiator was moved close to a plastic sheet on which had accumulated a heavy static charge. The initiator fired before it came into physical contact with the plastic sheet.

60. Almost invariably some form of transparent non-conductive viewplate is integral with a work area enclosure. This window should be treated to make it conductive, thereby eliminating the chance of establishing a bound charge configuration on the window. Untreated glass is apt to be less of an offender than the usual plastic windows because the glass tends to adsorb a conductive surface film from the air. On the basis of present knowledge it is difficult to specify just how conductive the treated surfaces should be. Certain films have been observed at this laboratory to measure less than 1000 ohms per square.*

LONG RANGE APPROACHES TO THE GENERAL PROBLEM

61. A consideration of the properties of lead wire carbon bridge initiators in relation to their susceptibility to initiation by electrostatic phenomena leads to some suggestions for design of devices in which these explosive components are to be installed. From an electrical standpoint these components are least dangerous to handle when enclosed in and in contact with a Faraday Shield. Therefore it would seem reasonable to design the weapon subassembly such that it is a total enclosure for the initiator. In the "safe" position the subassembly should provide an electrical short between the case and the leads. Circuits leading to the initiator should be shorted to the subassembly shell. It is likely in many current and future circuits that the achievement of such location features for the initiator will generate new design problems. The benefits to safe handling that could arise from achieving such design features should be worth considerable effort.

* Surface resistance measurements are taken between two, parallel, equal length contacts spaced apart a distance equal to the contact length. As long as the contacts delineate the opposite sides of a square, the resistance measurement for a uniform surface will be independent of the contact length. For this reason the resistance is stated in ohms per square and not in units of ohms per square inch, cm., etc.

62. It is probable that a new external configuration could lead to a major reduction in the susceptibility of carbon bridge initiators. By changing from long leads to prongs or to even shorter button type contacts there would be a smaller target for the spark to hit. If the contact or contacts were to be buried well inside the initiator case, the case would be its own Faraday Shield except for the opening in the case leading to the contact assembly. A new configuration, particularly the recessed contact type, might be difficult to achieve and might be beyond the present state of the art.

SAFETY CONCEPTS

63. An explosive component utilizing primary explosives is apt to be more sensitive to external energy -- mechanical, chemical, thermal, electrical -- than a component which does not utilize primary explosives. Often the main reason for the use of primary explosives is to make the component sufficiently sensitive for the intended use. It is thus sensible to consider explosive initiators, both primers and detonators, to be more apt to explode than leads or boosters since they would be more susceptible to the energy environment. This concept leads to the idea of out-of-line safety in explosives trains. Much ingenuity is displayed in designing the train so that the initiator will not be exploded at the wrong time. But, just in case the initiator should fire, the train is interrupted until the weapon is armed.

64. To be consistent an operator can be considered to be safe from a particular initiator only when there exists the certainty that the operator will not be hurt should the initiator explode. To attain this certainty the operator must be protected from the possible blast by barrier and/or by isolation. The barrier may be a part of the initiator environment or a personnel shield or both. Examples of environment barriers are ammunition cans, tote boxes, complete fuzes, or other containers from which could come no blast, missiles, or flame should the initiator fire. Labyrinth barricades or remote control total enclosures would be examples of personnel shields which would be judged totally safe by the criteria of the previous sentence. Any carriers or storage facilities would be considered safe if they can contain or dissipate the blast from the normal explosive quantity with an adequate safety factor and without hazard to personnel.

65. The design of equipment of the type mentioned in the previous paragraphs can be accomplished in a fairly straight forward manner using engineering techniques. However, when some portion of the operator's body must be placed in a vulnerable location, the situation becomes much more difficult to assess. The condition of vulnerability exists when there is either no barrier or an incomplete barrier between the initiator and some portion of the operator's body. Certain operations are very difficult to carry out with a barrier between the hands and the initiator, as for instance: the transfer of initiators from the initiator manufacturing line to shipping boxes, or from the box to firing chamber, or from box to weapon subassembly. It is a wise investment to analyze an operation sequence to verify the necessity for any zero-barrier steps and to redesign these steps to minimize the time of operator exposure to the unbarriered initiator. For other operations it is possible to give partial, but not complete, protection. Examples of partial protection are: (1) initiator installed in a subassembly which gives partial confinement or moderation; (2) initiators in a "tote box" which achieves a complete Faraday Shield but which would be breached should the normal number of initiators explode.

66. If the initiator were in a partial barrier which acted as a Faraday Shield, it would be tempting to define the operation as one requiring no extra personnel shielding except safety glasses because the Faraday Shield would prevent the firing of the initiators. That the Faraday Shield would prevent the firing of initiators by electrical energy external to the shield is at present an acceptable thesis. But there might be other phenomena that would fire the initiators. By word of mouth, it has been brought to the author's attention that mechanical initiators have been known to explode under very mysterious circumstances -- circumstances which suggest that an unexpectedly small amount of energy fired the initiator. It would thus be conceivable that an initiator inside a Faraday Shield might be fired by something other than electrical energy. To rely on the shield to prevent firing and therefore reduce physical protection of the operator falls in the category of taking a calculated risk. Unfortunately, the figures to use to calculate this risk are for the most part unknown.

CONTROL OF ELECTROSTATIC CHARGES

67. At the present time, there are some operations which require that electric initiators of the carbon bridge type be handled, during which the operator would be vulnerable should the initiator fire. The ideas presented in paragraphs 49 to 54, as they apply, can be used to examine such operations for safeness. These ideas, in part, are conveyed in the following statements:

a. A carbon bridge initiator can be considered safe from firing by electrical energy if these four criteria are satisfied:

- (1) If in a totally enclosed conducting shell
- (2) If the initiator leads and case are in constant contact with the conducting shell.
- (3) If no power sources are simultaneously contained within the conducting shell.
- (4) If there are no insulators within the shell, except those materials of which the initiator is made.

b. When an operator must be exposed to carbon bridge initiators, not in a Faraday Shield under the conditions listed in Paragraph a. above, the following points should be observed:

- (1) All operations should be carried out in a work enclosure which has minimum apertures for operator access and for flow of material.
- (2) All portions of the work enclosure, including the windows, must be conducting and grounded.
- (3) The operator and all conductors within 4 feet of the operator and work enclosure must be grounded during the time of operator vulnerability.
- (4) No non-conductors can be within 4 feet of the operator and work enclosure.

68. How much the safety of a particular situation is compromised by deviations from these statements may be very difficult to assess. It is hoped that the experiences and information set forth in this report will make such assessments easier. It must be remembered that in particular

NAVORD Report 3670

b(3) and b(4) probably cannot be fully attained. It represents a limit towards which effort should be directed. It is here stated, emphatically, that the foregoing paragraphs are not a complete presentation of the handling problems resulting from the susceptibility to static electricity. This is a complex domain. It is the author's opinion that there is much work that can be done profitably in investigating accident records, mechanisms of initiation, methods of sensing and controlling static charges and fields, and improving the recognition and solution of the mutual problems in the design of weapons and the design of their explosive components. It is also pointed out that no attempt has been made to cover all manners of initiation, inadvertent or intentional, of explosives components. Nor has any attempt been made to suggest safeguarding measures to cope with all manners of inadvertent initiations.

NAVORD Report 3670

DISTRIBUTION

	Copies
Chief of the Bureau of Ordnance, Department of the Navy, Washington 25, D. C.	
Technical Library	2
Re2b	1
Ma3a-1	1
Qc-2	2
In,Capt. Criddle	1
In,William Murphy	1
Officer in Charge, Safety Division, OIR, U. S. Navy Department, Pentagon Annex #1, Wash. D. C.	2
Commander, U. S. Naval Ordnance Test Station, Inyokern, China Lake, California	
B. A. Breslow	2
Technical Library	3
Commander, U. S. Naval Proving Ground, Dahlgren, Virginia	
Technical Library	3
Office of Naval Research, Department of the Navy, Washington 25, D. C.	1
Commanding Officer, Naval Ordnance Plant, Macon Georgia	2
Commanding Officer, U. S. Naval Ammunition Depot, Crane, Indiana	2
Chief of Ordnance, Department of the Army, Washington 25, D. C.	
ORDTA	3
ORDTX-AR	1
ORDTU	1
ORDIM	1
ORDGU-SA	2
District Chief, Philadelphia Ordnance District, 1500 Chestnut Street, Philadelphia 2, Penna.	1
Officer-In-Charge, Philadelphia Regional Office, Philadelphia Ordnance District, 16 South Broad St. Philadelphia, Penna.	1
Commanding Officer, Picatinny Arsenal, Dover, N. J.	
<u>Industrial Division</u>	
Production Engineering Br.	1
<u>Technical Division</u>	
Ammunition Dev. Br. A	1
Electrical Fuze Unit	1
Ammunition Dev. Br. B	1
Initiator Unit	1
Technical Library	3
Mr. McIvor	1
Mr. Hazelhurst	1

NAVORD Report 3670

DISTRIBUTION

	Copies
Commanding Officer, Frankford Arsenal, Philadelphia 37, Pennsylvania	
Artillery Ammunition Dept.	1
Pitman-Dunn Laboratories	1
Electronics (VT) Fuze Dept.	1
Technical Library	2
Commanding General, Aberdeen Proving Ground, Maryland	
Ballistic Research Laboratories	1
Development & Proof Service	1
Technical Library	2
Commanding Officer, Redstone Arsenal, Huntsville, Ala.	
Technical Library	2
Commanding General, Ordnance Ammunition Center, Joliet, Illinois	
E. G. Rapp	3
Officer-In-Charge, Office of Ordnance Research, 2127 Myrtle Ave., Duke University, Durham, N.C. .	1
Commanding Officer, Army Chemical Center, Edgewood, Md.	
Technical Library	1
Commanding Officer, Engineer Research & Development Labs, Fort Belvoir, Virginia	
Technical Library	1
Commanding General, Signal Corps Engineering Laboratories, Fort Monmouth, New Jersey	
Chief, Power Sources Branch, Squier Signal Lab. . .	1
Commanding General, Field Command, AFSWP, P.O. Box 5100, Albuquerque, New Mexico	1
Jefferson Proving Ground, Madison, Indiana	1
Milan Arsenal, Milan, Tennessee	1
Commanding General, White Sands Proving Ground, Los Cruces, New Mexico	1
Armed Services Technical Information Agency, Document Services Center, U.B. Building Dayton, Ohio	
DSC-SA	1
Chief of Staff, Department of the Air Force, Washington 25, D. C.	
DCS/D (AFDRD) Armament Division	1
Commanding General, Wright-Air Development Center, Wright-Patterson Air Force Base, Dayton, Ohio	
Armament Laboratory WCEGH	1
Technical Library	1
The Diamond Ordnance Fuze Labs, Wash. 25, D. C.	
ORD Div. Dev 13	1
ORD Div. Dev 16	1
ORD Div. Dev 17	1

NAVORD Report 3670

DISTRIBUTION

	Copies
The Diamond Ordnance Fuze Labs, Wash. 25, D. C.	
Technical Library	2
George Keene	1
Milton Lipnick	1
The Franklin Institute, Philadelphia 3, Penna.	
William Schilling	4
United States Atomic Energy Commission, Technical Information Service, Oak Ridge, Tennessee	
I. A. Warheit, Reference Branch	1
Canadian Arsenals Limited, Box 6112, Montreal, Quebec, Canada	6
Inspector of Naval Material, Ordnance Inspection Officer, 401 Old Post Office Building, Pittsburgh 19, Pennsylvania	1
Inspector of Naval Material, Newark District, Naval Industrial Reserve Shipyard, Bldg. 13 Port Newark, Newark 5, New Jersey	2
Inspector of Naval Material (Ordnance Inspection Officer) Big Four Building, 230 E. Ninth St. Cincinnati 2, Ohio	1
Inspector of Naval Material, Ordnance Inspection Officer, Wells-Gardner & Co., 2701 N. Kildare Ave. Chicago, Illinois	1
Inspector of Naval Material, 310 E. Jefferson Ave., Detroit, Michigan	1
Inspector of Naval Material, Elgin National Watch Co., Lincoln, Nebraska Ordnance Inspection Office	1
Naval Inspector of Ordnance, Eastman Kodak Co., 50 West Main Street, Rochester 14, N. Y.	2
Assistant Inspector of Naval Material, Ordnance Inspection Officer, Hamilton Watch Co., East Petersburg, Pennsylvania	2
Assistant Inspector of Naval Material, Post Office Annex, Room 329, Providence, R. I.	1
Ordnance Inspection Office, c/o Eclipse Machine Div. Bendix Aviation Corporation, Elmira, N. Y.	1
District Chief, Chicago Ordnance District, 209 West Jackson Blvd., Chicago 6, Ill.	1
District Chief, Spring Field Ordnance District Springfield Armory, Springfield, Mass.	1
District Chief, St. Louis Ordnance District, 1016 Olive Street, St. Louis 1, Missouri	1
District Chief, Boston Ordnance District Boston Army Base, Boston 10, Mass.	1

NAVORD Report 3670

DISTRIBUTION

	Copies
District Chief, Rochester Ordnance District, Sibley Tower Building, Rochester 4, N. Y. . .	1
District Chief, New York Ordnance District, 180 Varick Street, New York 14, N. Y. . . .	1
Admiral Corporation, 4150 N. Knox Avenue, Chicago 41, Illinois	2
Allied Plastics Incorporated, Los Angeles, Calif. W. T. Lingard	1
Armour Research Foundation, 34 West 33rd Street, Chicago, Illinois H. C. Miller, Asst. Chairman, Physics Research	1
Atlas Powder Company, Explosives Department, Reynolds Experimental Laboratory, Tamaqua, Schuylkill Co., Pa. R. McGirr	2
Atlas Powder Company, Explosives Manufacturing Div. Wilmington, Delaware George Gabiezda	1
The Baldwin Company, Ancor Plant, Newton, Ohio . .	2
Beckman Instruments, Inc., ARGA Division, Pasadena, California Dr. Taylor	1
Bulova Research & Development Labs, Inc. 40 - 23 Sixty-Second Street, Woodside 77, N.Y. E. F. Shelley	1
Bulova Watch Company, 425 Dexter Street, Providence, R. I. S. Lehrer	2
Chicago Electric Co, Chicago, Illinois Rodwick Oeljen	1
Crosley Division, AVCO Manufacturing Corp., 1329 Arlington St., Cincinnati, Ohio	2
Frank J. Curran Co., Downers Grove, Illinois . . .	1
Eastman Kodak Company, Naval Ordnance Division, 50 West Main Street, Rochester 4, N. Y. John Haas G. Gunnison	1 1
Eclipse-Pioneer Division, Bendix Aviation Corp. Teterboro, New Jersey R. C. Sylvander	1
Eclipse Machine Division, Bendix Aviation Corp. Elmire, New York	2
Elgin National Watch Company, Lincoln, Neb. . . .	2
Emerson Radio and Phonograph Corp, 111 8th Ave. New York, N. Y. D. D. Israel	1

NAVORD Report 3670

DISTRIBUTION

	Copies
Engineering Research Associates, 1902 W. Minnehaha Ave., St. Paul, Minn. W. F. Winget	1
Erie Resistor Company, Erie, Pennsylvania H. I. Oshry	1
Firestone Tire and Rubber Company, Defense Research Division, Akron 17, Ohio E. W. Ford	1
Hamilton Watch Company, Lancaster, Pennsylvania C. F. Brown F. A. Christoffel A. E. Fillinger	1 1 1
Hercules Powder Company, Port Ewen, New York G. H. Scherrer	1
Hercules Experiment Station, Explosives Research Division, Wilmington, Delaware J. Roth	1
International Harvester Company, Refrigeration Div., Evansville, Indiana Contract No. DA-33-008-ORD-378	1
King-Seeley Corporation, Ann Arbor, Michigan	2
Lone Star Ordnance Plant, Texarkana, Texas	1
The Magnavox Company, Fort Wayne 4, Indiana R. H. Severance	1
McQuay-Norris Manufacturing Co., 4100 Forest Park Blvd., St. Louis, Missouri	1
Minneapolis-Honeywell Regulator Co., Minneapolis 8, Minnesota Contract No. DA-11-022-ORD-914	1
National Fireworks Ordnance Corp., West Hanover, Mass. Mr. Condon	1
Ocean City Manufacturing Co., Philadelphia, Pa.	1
Olin Industries, Inc., 275 Winchester Ave., New Haven 4, Conn. Lyle Sheldon Contract DAI-28-017-501-ORD-(P)-1159(1)	1 1
Ordnance Engineering Corp., Rochville, Md.	1
Parke Thompson Associates, 501 South Holmes, Kirkwood 22, Missouri	1
Parker Pen Company, Janesville, Wisconsin Daniel Parker	1
Patterson, Moos and Company, Inc. 90-28 Van Wyck Expressway, Jamaica 18, New York Dr. Moos	1

NAVORD Report 3670

DISTRIBUTION

	Copies
RCA Victor Television Division, Bldg. #40, Canonsburg, Pennsylvania	
P. Collier; Process Engineering	1
C. H. Eisengrein; Safety and Plant Facilities	1
B. O. Heady; Quality Control	1
D. Hill; Incoming Inspection	1
D. K. Obenland; Mgr. Government Engineering	1
R. J. Wiggs; Manufacturing	1
Regal Electronics Corporation, 603 West 130th St., New York 27, N. Y.	
M. Weinstein	1
Rheem Manufacturing Co. R&D Labs., 9236 E. Hall Rd., Downey, California	
Mr. Carson	1
M. H. Rhodes, Inc., 20 Bartholomew Ave., Hartford, Conn.	
M. E. Doyle	1
Stewart-Warner Corporation, 1826 Diversey Parkway, Chicago 14, Illinois	
G. H. Hynard	1
Underwood Corporation, 581 Capitol Ave., Hartford, Conn.	
G. C. Dickerson	1
United States Time Corporation, Waterbury 91, Conn.	
H. S. Brazee	1
United States Time Corporation, Municipal Airport, Little Rock, Arkansas	1
Universal Match Co., Ferguson, Missouri	
H. Ellern	2
R. Feero	1
University of Arkansas, Institute of Science & Technology, Fayetteville, Arkansas	
Z. V. Harvalik	1
Wells Gardner & Co., 2701 N. Kildare Ave., Chicago, Illinois	2
Wesleyan University (ORDWES), Windsor Locks, Conn.	
R. G. Clarke, P.O. Box 647	1
Western Cartridge Co., East Alton, Illinois	1
Westinghouse Electric Corporation, Metuchen, N. J.	2
Zenith Radio Corporation, 6001 W. Dickens Ave., Chicago 39, Illinois	
Dr. Ellett	1
Clarence Wandry	1

Armed Services Technical Information A

Because of our limited supply, you are requested to return this copy WHEN IT HAS YOUR PURPOSE so that it may be made available to other requesters. Your cooperation will be appreciated.

AD

45850

NOTICE: WHEN GOVERNMENT OR OTHER DRAWINGS, SPECIFICATIONS OR OTHER DATA ARE USED FOR ANY PURPOSE OTHER THAN IN CONNECTION WITH A DEFINITELY IDENTIFIED GOVERNMENT PROCUREMENT OPERATION, THE U. S. GOVERNMENT THEREBY ASSUMES NO RESPONSIBILITY, NOR ANY OBLIGATION WHATSOEVER; AND THE FACT THAT THE GOVERNMENT MAY HAVE FORMULATED, FURNISHED, OR IN ANY WAY SUPPLIED SAID DRAWINGS, SPECIFICATIONS, OR OTHER DATA IS NOT TO BE REGARDED AS AN IMPLICATION OR OTHERWISE AS IN ANY MANNER LICENSING THE HOLDER OR USER, OR PERSON OR CORPORATION, OR CONVEYING ANY RIGHTS OR PERMISSION TO MAKE, REPRODUCE, USE OR SELL ANY PATENTED INVENTION THAT MAY IN ANY WAY BE RELATED TO SAID DRAWINGS, SPECIFICATIONS, OR OTHER DATA.

Reproduced by
DOCUMENT SERVICE CENTER
KNOTT BUILDING, DAYTON 2, OHIO

UNCLASSIFIED