

UNCLASSIFIED

AD NUMBER

AD046044

LIMITATION CHANGES

TO:

Approved for public release; distribution is unlimited.

FROM:

Distribution authorized to DoD only; Administrative/Operational Use; FEB 1954. Other requests shall be referred to Bureau of Ships, Washington, DC.

AUTHORITY

BUSHIPS ltr, 1 Apr 1968

THIS PAGE IS UNCLASSIFIED

Armed Services Technical Information Agency

Because of our limited supply, you are requested to return this copy WHEN IT HAS SERVED YOUR PURPOSE so that it may be made available to other requesters. Your cooperation will be appreciated.

AD

46044

NOTICE: WHEN GOVERNMENT OR OTHER DRAWINGS, SPECIFICATIONS OR OTHER DATA ARE USED FOR ANY PURPOSE OTHER THAN IN CONNECTION WITH A DEFINITELY RELATED GOVERNMENT PROCUREMENT OPERATION, THE U. S. GOVERNMENT THEREBY INCURS NO RESPONSIBILITY, NOR ANY OBLIGATION WHATSOEVER; AND THE FACT THAT THE GOVERNMENT MAY HAVE FORMULATED, FURNISHED, OR IN ANY WAY SUPPLIED THE SAID DRAWINGS, SPECIFICATIONS, OR OTHER DATA IS NOT TO BE REGARDED BY IMPLICATION OR OTHERWISE AS IN ANY MANNER LICENSING THE HOLDER OR ANY OTHER PERSON OR CORPORATION, OR CONVEYING ANY RIGHTS OR PERMISSION TO MANUFACTURE USE OR SELL ANY PATENTED INVENTION THAT MAY IN ANY WAY BE RELATED THERETO.

Reproduced by
DOCUMENT SERVICE CENTER
KNOTT BUILDING, DAYTON, 2, OHIO

UNCLASSIFIED

AD-46044



**SECOND INTERIM DEVELOPMENT REPORT
FOR
FERRITE COMPONENTS PROGRAM**

THIS REPORT COVERS THE PERIOD 17 OCTOBER 1953 TO 17 JANUARY 1954

**FURTHER DISSEMINATION IS AUTHORIZED ONLY TO
MILITARY AGENCIES.**

**SPERRY GYROSCOPE COMPANY
DIVISION OF THE SPERRY CORPORATION
GREAT NECK, NEW YORK**

**NAVY DEPARTMENT, BUREAU OF SHIPS, ELECTRONICS DIVISION
CONTRACT NO. NObsr 63312, INDEX NO. NE-111616
SUBTASK 14**

**SPERRY REPORT
NO. 5224-1339-2**

**COPY NO. 3
FEBRUARY 1954**

ABSTRACT

This second interim report summarizes the work accomplished in the experimental and development phases of the ferrite program during the period from 17 October 1953 to 17 January 1954. The following microwave properties of eight commercially available ferrites were investigated in circular waveguide: ferrite absorption loss, VSWR, axial ratio, and rotation of plane of polarization -- each as a function of applied magnetic field, and with length and diameter of the ferrite sample as parameters. The frequency sensitivity of three ferrite samples was examined. Some information was obtained on the microwave properties of ferrites located in rectangular waveguide in an applied transverse magnetic field. Experimental versions of a modulator, attenuator, and switch were built and some performance data were obtained.

TABLE OF CONTENTS

Abstract

List of Illustrations

<u>Paragraph</u>		<u>Page</u>
PART I		
SECTION A - PURPOSE		
1	Purpose of Program	1
2	Breakdown into Working Phases	1
	a. Experimental Phase	1
	b. Development Phase	2
SECTION B - GENERAL FACTUAL DATA		
3	References	4
4	Formulae and Definitions	5
5	Measurement Procedures	8
	a. Introduction	8
	b. Precision Measurement Setup	9
	Used for Studies in Rectangular Waveguide	
	c. Measurement Setup Used to Deter- mine Percent Modulation	10

TABLE OF CONTENTS (CONT)

<u>Paragraph</u>		<u>Page</u>
	SECTION C - DETAIL FACTUAL DATA	
6	Summary of Previous Interims	12
7	Properties of Ferrites in Rectangular Waveguide	13
8	Experimental Data on Ferrites	21
9	Component Development	24
10	Project Performance and Schedule	32
	SECTION D - CONCLUSIONS	
11	Conclusions	33
	PART II	
	PROGRAM FOR NEXT INTERVAL	
12	Program for Third Interim	35
	PART III	
	APPENDIX	
13	Equipment Required for Precision Measurement Setup Used for Studies in Rectangular Waveguide	37
14	Equipment Required for Modulation Measurements	38

LIST OF ILLUSTRATIONS*

<u>Figure</u>	<u>Title</u>
1	Precision Measurement Setup Used for Studies in Rectangular Waveguide, Interconnection Diagram
2	Measurement Setup Used to Determine Percent Modulation, Interconnection Diagram
3	Ferrites in Rectangular Waveguide
4	Magnetic Field in Rectangular Waveguide for TE_{10} Mode
5	Microwave Properties of Ferramic A-106 in Circular Waveguide, with Length as Parameter
6	Microwave Properties of Ferramic A-106 in Circular Waveguide, with Diameter as Parameter
7	Microwave Properties of Ferramic B-90 in Circular Waveguide, with Length as Parameter
8	Microwave Properties of Ferramic B-90 in Circular Waveguide, with Diameter as Parameter
9	Microwave Properties of Ferramic C-159 in Circular Waveguide, with Length as Parameter
10	Microwave Properties of Ferramic C-159 in Circular Waveguide, with Diameter as Parameter
11	Microwave Properties of Ferramic D-216 in Circular Waveguide, with Diameter as Parameter
12	Microwave Properties of Ferramic G-254 in Circular Waveguide, with Length as Parameter
13	Microwave Properties of Ferramic G-254 in Circular Waveguide, with Diameter as Parameter

* Illustrations are grouped in numerical order at the rear of this report.

LIST OF ILLUSTRATIONS (Cont)

<u>Figure</u>	<u>Title</u>
14	Microwave Properties of Ferramic H-419 in Circular Waveguide, with Length as Parameter
15	Microwave Properties of Ferramic H-419 in Circular Waveguide, with Diameter as Parameter
16	Microwave Properties of Ferramic I-141 in Circular Waveguide, with Length as Parameter
17	Microwave Properties of Ferramic I-141 in Circular Waveguide, with Diameter as Parameter
18	Microwave Properties of Ferramic J-472 in Circular Waveguide, with Length as Parameter
19	Microwave Properties of Ferramic J-472 in Circular Waveguide, with Diameter as Parameter
20	Microwave Properties of Ferramic 1331 in Circular Waveguide, with Length as Parameter
21	Microwave Properties of Ferramic 1331 in Circular Waveguide, with Diameter as Parameter
22	Microwave Properties of Ferramic A-106 in Circular Waveguide, with Frequency as Parameter
23	Microwave Properties of Ferramic D-216 in Circular Waveguide, with Frequency as Parameter
24	Microwave Properties of Ferramic 1331 in Circular Waveguide, with Frequency as Parameter
25	Microwave Properties of Ferramic 1331 in Rectangular Waveguide, with Location of Ferrite as Parameter
26	Determination of Planes of Circular Polarization in Rectangular Waveguide using Ferramic 1331
27	Microwave Property of Ferramic A-106 in Rectangular Waveguide at Plane of Circular Polarization

LIST OF ILLUSTRATIONS (Cont)

<u>Figure</u>	<u>Title</u>
28	Type 1 Attenuator, Modulator, and Switch, Cross Section
29	Percent Power Modulation vs Temperature for Type 1 Modulator Using Ferramic 1331, with Frequency as Parameter
30	Total Transmission Loss vs Frequency for Type 1 Modulator Using Ferramic 1331, with Temperature as Parameter
31	Percent Power Modulation vs Temperature for Type 1 Modulator Using Two Samples of Ferramic A-106, with Frequency as Parameter
32	Percent Power Modulation vs Temperature for Type 1 Modulator Using Ferramic D-216, with Frequency as Parameter
33	Total Transmission Loss vs Temperature for Type 1 Switch Using Ferramic 1331, with Frequency as Parameter
34	Total Transmission Loss vs Coil Current for Type 1 Attenuator Using Ferramic 1331
35	VSWR vs Ferrite Position for Type 1 Attenuator Using Ferramic 1331
36	VSWR vs Frequency for Type 1 Attenuator Using Ferramic 1331, at Points of Maximum and Minimum Transmission
37	Total Transmission Loss vs Frequency for Type 1 Attenuator Using Ferramic 1331, at Points of Maximum and Minimum Transmission
38	Project Performance and Schedule

PART I
SECTION A
PURPOSE

1. PURPOSE OF PROGRAM

- This program is concerned with the study of the microwave properties of commercially available ferrites, and the development of microwave components using these ferrites as the active element. This work will be conducted in the frequency range of 8500 to 9600 mc.

2. BREAKDOWN INTO WORKING PHASES

a. Experimental Phase

The properties of existing ferrites will be studied and data obtained on the following characteristics:

- (1) specific rotation
- (2) absorption loss in ferrite
- (3) phase-shift properties
- (4) axial ratio of emergent radiation
- (5) hysteresis effects
- (6) any other pertinent properties discovered
- (7) reproducibility of data

The shapes of the ferrite samples to be investigated are cylinders and plates. The parameters to be varied are as follows:

- (1) dimensions of sample
- (2) dimensions of waveguide
- (3) frequency of microwaves
- (4) level of microwave power
- (5) strength of magnetic field
- (6) orientation of magnetic flux with respect to waveguide axis
- (7) temperature of sample

b. Development Phase

With the aid of the data supplied under the research phase, the following components are to be developed in 1" x 1/2" waveguide for use in the frequency range of at least 8500 to 9600 mc:

- (1) low-power modulator (power level of one watt or less)
- (2) high-power modulator (power level as much above one watt as possible)
- (3) nonbilateral transmission unit (power level as high as possible)
- (4) phase shifter

- (5) variable attenuator having a loss dependent upon
the applied magnetic field
- (6) microwave switch

SECTION B
GENERAL FACTUAL DATA

3. REFERENCES

First Interim Development Report for Ferrite Components Program, furnished by Sperry Gyroscope Company to Bureau of Ships under Contract No. NCbsr 63312.

Kales, M.L., H.N. Chait, and N.G. Sakiotis, "A Nonreciprocal Microwave Component," Journal of Applied Physics, Vol. 24, pp. 816-817, June, 1953.

Polder, D., "On the Theory of Ferromagnetic Resonance," Philosophical Magazine, Vol. 40, pp. 99-115, January, 1949.

Rowen, J.H., "Ferrites in Microwave Applications" Bell System Technical Journal, Vol. 32, pp. 1333-1369, November, 1953.

Sakiotis, N.G. and H.N. Chait, "Properties of Ferrites in Waveguides," Transaction of the I.R.E. Professional Group on Microwave Theory and Techniques, Vol. M.T.T.-1, pp. 11-16, November, 1953.

4. FORMULAE AND DEFINITIONS

a. Ferrite Types

All ferrites mentioned in this report are manufactured by the General Ceramic and Steatite Corporation and will hereafter be referred to by their type designation preceded by the word "Ferramic".

b. Modulation Factor (F_v and F_p)

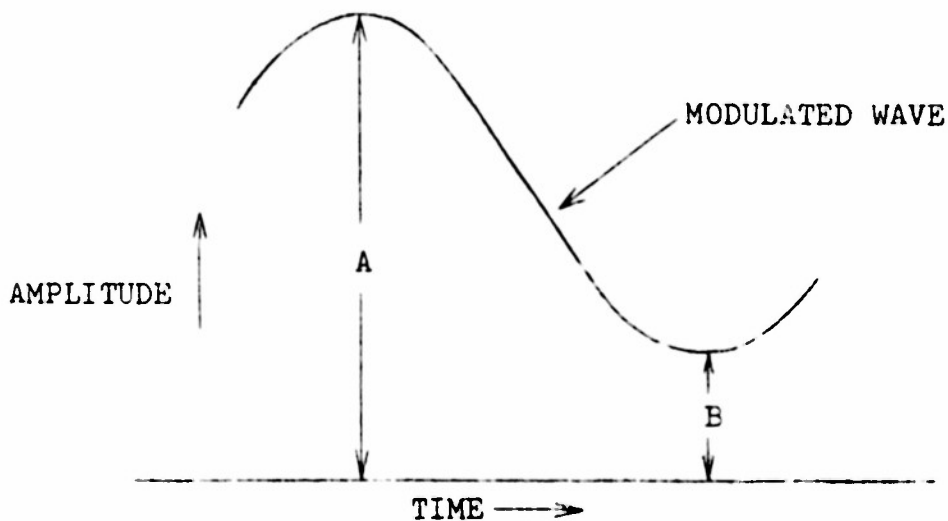

Modulation factor is defined as the ratio of the peak variation actually used ($A-B$) to the maximum possible design variation (A). When A and B are voltage amplitudes:

$$\text{voltage modulation factor} \quad F_v = \frac{A-B}{A} \quad (1)$$

When A and B are power amplitudes:

$$\text{power modulation factor} \quad F_p = \frac{A-B}{A} \quad (2)$$

In the case of microwave modulators, note that amplitude A is not variable. The percent modulation is obtained by multiplying F_v or F_p by 100.

c. Harmonic Distortion (D_v and D_p)

For the n^{th} harmonic, the percent voltage distortion D_v and the percent power distortion D_p are defined as the ratio of the maximum amplitude of the n^{th} harmonic to the maximum amplitude of the fundamental, multiplied by 100 (where these amplitudes are voltages for D_v and powers of D_p). In the case of hysteresis, the criterion for distortion would involve a Fourier series with phase and amplitude for each harmonic component. The quantities defined above should be considered as approximate figures of merit in view of the difficulty and expense of obtaining the phase information.

It should be noted that when power modulation is being considered, only the definition of power distortion will be used; for voltage modulation, only that of voltage distortion will be used.

d. Hysteresis of Total Transmission Loss (α_h)

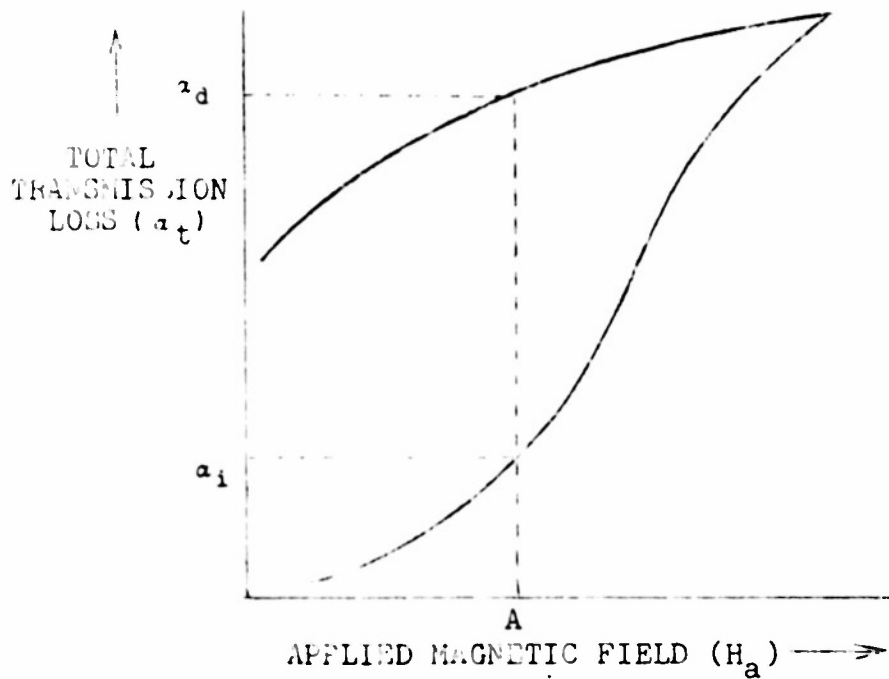

The hysteresis of total transmission loss (for a given ferrite component and for any value of applied magnetic field, A) is defined as the magnitude of the difference in decibels between (1) the value of total transmission loss at A when the applied magnetic field is increasing and (2) the total transmission loss at A when the applied magnetic field is decreasing. Therefore,

$$\alpha_h = \alpha_d - \alpha_1 \quad (3)$$

where

$$\alpha_d = \alpha_t \text{ when } H_a \text{ is decreasing}$$
$$\alpha_i = \alpha_t \text{ when } H_a \text{ is increasing}$$

Not only does the value of α_h depend upon A but also upon the magnetic history of the ferrite sample.

5. MEASUREMENT PROCEDURES

a. Introduction

As a part of the ferrite components development program, it is necessary to study ferrite samples located in rectangular waveguide with an applied transverse static magnetic field. These samples are being tested for total transmission loss, VSWR, and phase shift --each as a function of the frequency and of the strength and direction of the applied magnetic field. The effects of temperature, ferrite shape, and the location of sample in the waveguide are also being studied. These tests are performed using both a precision measurement setup (for detailed information) and an automatic setup (for rapidly surveying general behavior). The automatic setup that is used is the same as the one described in the first interim report. The new precision measurement setup will be described in the following paragraphs. A new setup used to determine percent power modulation is also described.

b. Precision Measurement Setup Used for Studies in
Rectangular Waveguide

The precision measurement setup used for obtaining data on ferrite cylinders and rectangular slabs located in rectangular waveguide is shown in figure 1. In the discussion of this setup, a numeral in parenthesis following an item refers to the same item pictured in figure 1. A detailed list of the equipment required is given in the Appendix.

The test chamber consists of a 5" section of X-band rectangular waveguide situated in a 1/2" gap in the core of an electromagnet. The ferrites are placed in the chamber along the direction of propagation, and microwave energy in the dominant TE_{10} mode is passed into the cell.

The pole face of the electromagnet has an area of 1-1/4" x 3-3/8" and a separation of 1/2". The magnet is capable of generating a field continuously variable from 0 to 5500 gauss as the coil current is varied from 0 to 3 amperes. This magnetic field is applied perpendicular to the direction of propagation of the microwaves. Measurements show that the field varies only ± 1 percent over a length of 3".

A heterodyne method, using a microwave receiver (11) and calibrated couplers, is used to measure the total transmission loss of the ferrite (figure 1). These measurements are made by first obtaining a reference level P_i at one directional coupler (6a), and then measuring the power difference in decibels between P_i at the first coupler (6a) and P_o at the second coupler (6b). The VSWR due to the reflected power P_r is measured by using an r-f impedance meter (5) and microwave receiver (11).

The absorption loss of the ferrite (a_f) is determined by measuring the power difference in decibels between the two couplers (6a and b), and then measuring and subtracting the power loss due to reflections:

$$a_f = 10 \log \frac{P_i - P_r}{P_o} \quad (4)$$

Absorption losses measured with this setup are accurate to ± 0.1 db.

c. Measurement Setup Used to Determine Percent Modulation

Figure 2 shows the setup used in measuring the percent modulation. Because of the square-law properties of the crystal detector (8), this system indicates power; hence, the power definitions of modulation and distortion given in paragraph 4 of this report apply. A coupler (12) is used to

monitor the power to assure operation in the square-law region of the crystal. A power level of 1 mw is set on a bridge (7) giving a -20-dbm level at the crystal. In order to reduce distortion, a constant-current generator (13) is used to maintain the waveshape of the applied current independent of the load; in this case, the load is non-linear because of the ferrite. The actual measurement of power modulation was performed on an oscilloscope (9) by measuring the detected envelope. Harmonic distortion was measured on a harmonic analyzer (11).

SECTION C
DETAIL FACTUAL DATA

6. SUMMARY OF PREVIOUS INTERIMS

Two systems have been described so far: one being especially suited for precise measurements, and the other for rapidly surveying general behavior. Sample curves were submitted to demonstrate the performance of the rapid (automatic) setup. By means of the precision setup, microwave properties have been determined and presented for Ferramic D-216 in circular waveguide, with length of sample as a parameter.

With reference to statements made in paragraph 6 of the first interim report, note the following additions and corrections which are represented by the underlined words:

Only those ferrites in which M is magnesium, copper, manganese, lithium, nickel, cobalt, calcium, lead, or iron are ferromagnetic.

Ferrites in which M is zinc or cadmium display certain magnetic properties, but are not ferromagnetic.

7. PROPERTIES OF FERRITES IN RECTANGULAR WAVEGUIDE

In an article published in 1949^{*}, Polder developed a theory which described the behavior of microwaves propagating in an infinite ferromagnetic medium saturated by a static magnetic field. He showed that the intensity of the r-f magnetic field and the r-f flux density are related by a tensor permeability. Polder's solution of Maxwell's equations for a plane wave incident on such a ferromagnetic medium (magnetized to saturation by an applied static magnetic field directed parallel to the direction of propagation) was discussed in the first interim report. The case of a ferromagnetic medium saturated by an applied static magnetic field transverse to the direction of propagation will be treated in this report.

In general, for a plane wave propagating in a saturated ferromagnetic medium of infinite length magnetized in any arbitrary direction with respect to the direction of propagation, Maxwell's equations yield two solutions which represent two elliptically polarized waves, propagated in the same direction but with different velocities.

- - - - -
* D. Polder, "On the Theory of Ferromagnetic Resonance," Philosophical Magazine, Vol. 40, pp. 99-115, January, 1949.

The special solution for the case of a plane wave propagating in a saturated ferromagnetic medium magnetized parallel to the direction of propagation represents two circularly polarized waves rotating in opposite directions. If, instead of an infinite ferromagnetic medium, a finite length of material is used, the emergent wave will be elliptically polarized and its major and minor axes will be rotated through a certain angle with respect to the incident wave. The ellipticity is produced by the differential attenuation of the two circularly polarized waves. The differential phase shift of the two waves gives rise to the observed rotation.

For the case of an infinite medium magnetized perpendicular to the direction of propagation, the solution of Maxwell's equations for plane waves represents two orthogonal linearly polarized waves. One wave has its E-vector polarized parallel to the direction of magnetization and has a phase velocity which is a function of magnetization of the medium. This is the "extraordinary" wave. The other wave is polarized perpendicular to the direction of magnetization and has a phase velocity which is not a function of the magnetization of the medium. This represents the "ordinary" wave.

Polder's theory was derived for plane waves propagating in an infinite ferromagnetic medium, homogeneously magnetized to saturation. In the case of propagation in rectangular waveguide, these conditions do not hold completely. The infinite ferromagnetic medium does not exist. Also, plane waves do not exist in waveguide; rather, cylindrical waves are present in several modes of propagation. In any waveguide, one mode will be the dominant mode; in 1" x 1/2" O.D. rectangular waveguide, this is the TE_{10} mode.

In a ferrite-loaded waveguide, the ferrite piece, though small in cross section, may excite higher-order modes. These modes will be either transverse electric or transverse magnetic, but the TE_{10} mode will always be present. The higher-order modes can propagate only in the section of waveguide containing the ferrite.

Polder's theory can be used as a reasonable approximation for the case of a static magnetic field applied perpendicular to the broad dimension of rectangular waveguide which is propagating energy in the dominant TE_{10} mode. In X-band waveguide, the wave polarized perpendicular to the direction of magnetization sees a waveguide which is beyond cutoff, and therefore cannot be propagated past

the ferrite section. This leaves only the extraordinary wave; its characteristics can be controlled to a certain degree by varying the magnetization of the medium since its properties are functions of this magnetization.

The phase velocity and absorption of a wave being propagated in a ferrite-loaded rectangular waveguide, depend upon the geometry, type, magnetization, temperature, and position of the ferrite in the waveguide.

For the case shown in figure 3, the direction of propagation is along the y axis and the magnetic field is applied along the z axis. Under these conditions, it is possible to construct either a reciprocal or nonreciprocal element, depending upon the location of the ferrite in the waveguide. The reciprocal or nonreciprocal properties of a ferrite-loaded waveguide situated in a transverse magnetic field have been shown theoretically for all modes which are independent of the z coordinate.* According to this analysis, with the static magnetic field applied along the z axis as shown in figure 3, the microwave components of B and H can be written as follows:

- - - - -

* M.L. Kales, H.N. Chait, and N.G. Sakiotis, "A Nonreciprocal Microwave Component," Journal of Applied Physics, Vol. 24, pp. 816-817, June, 1953.

$$B_x = \mu H_x - j \mu' H_y \quad (5)$$

$$B_y = j \mu' H_x + \mu H_y \quad (6)$$

$$B_z = \mu H_z \quad (7)$$

where μ = low-frequency portion of the initial permeability

μ' = high-frequency portion of the initial permeability

The dielectric constants and permeabilities of the empty waveguide and those of the ferrite-loaded waveguide are represented by ϵ_1, μ_1 and ϵ_2, μ_2 respectively. Let

$$\mu_2 = \mu \left[1 - \left(\frac{\mu'}{\mu} \right)^2 \right] \quad (8)$$

and assume an $e^{-j\beta y}$ y dependence. It has been shown that the propagation constant β then satisfies the following equation:

$$\left[\mu_2^2 K_1^2 - \mu_1^2 \left[K_2^2 + \left(\beta \frac{\mu'}{\mu} \right)^2 \right] \tan K_1 d \tan K_1 d' \right] \tan K_2 t + \mu_1 \mu_2 K_1 K_2 [\tan K_1 d + \tan K_1 d'] - \beta \frac{\mu'}{\mu} [\tan K_1 d - \tan K_1 d'] \tan K_2 t = 0 \quad (9)$$

where

$$K_1^2 = \omega^2 \epsilon_1 \mu_1 - \beta^2$$

$$K_2^2 = \omega^2 \epsilon_2 \mu_2 - \beta^2$$

If the ferrite piece is symmetrically located within the waveguide, $d=d'$, and the last term vanishes. The propagation constant will then have the same value for either direction of propagation. However, for the asymmetric case, where $d \neq d'$, the last term does not vanish and the equation is no longer symmetrical in β . In the latter case, the propagation constant will not be the same for the two directions of propagation.

Therefore, in the asymmetrical case, a change in the direction of propagation will result in a change in the attenuation and phase constant. This permits the construction of a nonreciprocal component with a ferrite piece as the active element. The relationship of a to a' in figure 3b and d to d' in figure 3a controls the nonreciprocal properties of the component. Thus, in considering the effects of ferrites in rectangular waveguide, the location of the ferrite in the waveguide is of major importance. For studies of the symmetrical properties of the ferrite-loaded waveguide, the ferrite sample is located at the center of the waveguide or at the center of the broad wall of the

waveguide (see figure 3). In the study of the asymmetrical properties, tests show that if the ferrite is placed in the waveguide where H vector of the normal waveguide mode is circularly polarized, for certain values of applied magnetic field the component has a very large attenuation for one direction of propagation and a much smaller attenuation for the opposite direction. An explanation of this effect has been obtained from the theory of gyromagnetic resonance.* If the r-f magnetic field is circularly polarized in a plane perpendicular to the direction of magnetization of the ferrite, a large absorption of power will occur at that value of applied magnetic field and frequency which will bring the ferrite into gyromagnetic resonance (provided the sense of polarization is positive with respect to the direction of the applied magnetic field). This large resonant absorption of power does not take place for the negative sense of polarization.

In the case of a rectangular waveguide propagating energy in the dominant TE_{10} mode, there are two parallel planes so located (equidistant from the narrow faces of the

- - - - -
* N.G. Sakiotis and H.N. Chait, "Properties of Ferrites in Waveguides," Transactions of the I.R.E. Professional Group on Microwave Theory and Techniques, Vol. M.T.T.-1, pp.11-16, November, 1953.

waveguide) that, at any point in these planes, the H vector of the normal waveguide mode is circularly polarized. In either plane, the circular polarization is of one sense for one direction of microwave propagation and of the opposite sense for the opposite direction of propagation. This arises from the fact that, at the two planes, the longitudinal and transverse components of the H vector are in phase quadrature and of equal amplitude (see figure 4). These are, by definition, the conditions for circular polarization. However, the longitudinal components are 180 degrees out of phase at one plane as compared with the same component at the other plane (see figure 4). This change in sign is equivalent to a 180-degree phase shift, and the H vector of the wave is circularly polarized in the positive sense in one plane and in a negative sense in the other plane. If either the direction of propagation or the direction of applied magnetic field is reversed, the senses of polarization are reversed.

The presence of a ferrite in waveguide effects the location of the planes of circular polarization of the H vector. For the case of an air-filled waveguide, the planes of circular polarization are located at a distance one quarter of the broad dimension from the narrow wall. For the case of a ferrite-loaded waveguide, the planes of circular

polarization will be shifted by a small amount. The amount the planes are shifted is determined by the size and geometry of the inserted ferrite, and also by a change in frequency of the incident radiation.

8. EXPERIMENTAL DATA ON FERRITES

Data on the microwave properties of ferrites in circular waveguide with an applied longitudinal magnetic field has been obtained on several samples of commercially available ferrites. This data consists of ferrite absorption loss, VSWR, axial ratio, and rotation of plane of polarization; each property has been taken as a function of the intensity of applied magnetic field, with length and diameter of the ferrite samples as parameters. Measurement of the above properties was made on the following types of Ferramics: A-106, B-90, C-159, D-216, G-254, H-419, I-141, J-472, and 1331. The frequency and temperature were held constant at 9600 mc and 23°C (73°F), respectively. The data is shown in figures 4 through 21. Of the ferrites tested, Ferramics A-106 and 1331 have the lowest ferrite absorption loss. Ferramic 1331 is the better rotator of the two, but Ferramic A-106 has a more predictable set of characteristics. In the case of Ferramic A-106 magnetized to saturation, the rotation of the plane of polarization increases linearly with increasing frequency, and the ferrite absorption

loss decreases with increasing frequency. At a length of 3.00" and a diameter of 0.375", Ferramic 1331 has a VSWR of seven and a ferrite absorption loss of approximately 8 db over a very narrow region of applied magnetic field (figure 21). Also, a similar effect has been observed in Ferramic 1331 for a length of 1.13" and a diameter of 0.250". In both cases, the effect was observed with an applied magnetic field of 100 to 150 gauss. A reversal of the direction of rotation for various sample diameters has been observed for Ferramics B-90, C-159, G-254, H-419, and J-472 (figures 8, 10, 13, 15, and 19, respectively). This reversal of rotation was observed for Ferramics H-419 and C-159, having diameters of 0.250" and 0.375", and for Ferramics B-90, G-254, and J-472 having a diameter of 0.375". The length of all samples was 3.00".

Data taken on the microwave properties of ferrites in an applied longitudinal magnetic field with frequency as the parameter is shown in figures 22 through 24. This data was obtained from cylindrical samples of Ferramics A-106, D-216, and 1331, all 3.00" long and 0.250" in diameter. The rotation of plane of polarization at saturation varies over the following limits: from 640 degrees at 9600 mc to 230 degrees at 8500 mc in Ferramic D-216, from 575 degrees at 9600 mc to 220 degrees at 8500 mc in Ferramic 1331, and from

240 degrees at 9600 mc to 140 degrees at 8500 mc in Ferramic A-106. This change in the rotation of plane of polarization is approximately linear with respect to changes in frequency. The ferrite absorption loss, VSWR, and axial ratio also change as a function of frequency, but in a nonuniform manner. It is significant that in contrast to other ferrites, the absorption loss in Ferramic A-106 shows a definite increase with a decrease in frequency (figure 22).

The microwave properties of ferrite cylinders located in rectangular waveguide in an applied transverse magnetic field are being investigated. Measurements of ferrite absorption loss vs applied magnetic field, using Ferramic 1331, with the location of the ferrite in the waveguide as a parameter, are shown in figure 25. When the ferrite sample is located along the center of the broad dimension of the waveguide, the ferrite sample exhibits symmetrical-propagation characteristics for any value of applied static magnetic field. This is also approximately true for the case of the ferrite sample located in one corner of the waveguide. However, with the sample located in the plane of circular polarization, a large differential absorption loss is observed (figures 25 and 26). The point of circular polarization, determined at 9000 mc, using a ferrite cylinder 0.122" wide and 3.00" long, was found

to be 0.210" from the narrow wall of the waveguide (figure 26).

The nonreciprocal properties of a component of this type (that is, with the ferrite located along the plane of circular polarization of the H vector) are of special interest.* Using Ferramic A-106 as the active element, a one-way transmission system can readily be obtained with an attenuation of 2.4 db in the forward direction and 32 db in the opposite direction (figure 27). If Ferramic 1331 is used as the active element, an attenuation of 3.4 db is observed in the forward direction and 41 db in the opposite direction (figure 26).

9. COMPONENT DEVELOPMENT

a. Introduction

The development phase during the second quarter consisted of testing various units for use as modulators, attenuators, and switches. The information furnished in the following paragraphs was obtained on experimental models and should not be considered as final; as new techniques and

* Sakiotis, "Ferrites in Waveguides."

materials are developed, changes can be expected. All components were tested in a crossed-waveguide position as shown in figure 28.

The operation of all units to be described in this report depends upon the rotation of the emergent wave with respect to the incident wave due to the applied magnetic field (Faraday effect, described in first interim report).

When the symbol H_a is used, it is understood to mean the applied magnetic field.

b. Ferrite Modulators

A microwave modulator is a device which can cause a prescribed change in the microwave signal passing through it. These changes can be made to occur in the amplitude, phase, or frequency, depending upon the application.

Although frequency modulation is feasible by means of variable phase shifting, only amplitude modulators have been considered here, as this type has more immediate application.

The modulator shown in figure 28, hereafter called the type 1 modulator, is an amplitude modulator of the simplest design. It uses a piece of ferrite located along

the axis of a section of circular waveguide. The resistor card absorbs that component of the rotated wave whose E vector is in the plane of the card. Hence, if the applied magnetic field H_a is varied, the rotation of the plane of polarization θ is varied, and the emergent microwave energy will be modulated. The manner in which H_a and θ are related for Ferramic 1331 is shown in figure 24.

Three of the basic criteria for a modulator are the percent modulation possible, the harmonic distortion present, and the frequency of modulation possible. Other criteria are hysteresis, insertion loss, microwave-frequency sensitivity, and temperature variations.

The percent modulation is determined by such characteristics as those shown in figure 24. These curves define the applicable operating range of the total transmission loss (in decibels) of the ferrite component. For a sample of Ferramic 1331, 3.00" long and 0.250" wide, the maximum range of applied magnetic field, H_a , over which H_a and the rotation of plane of polarization are linearly related, is about 20 gauss. Over this range, the following relation exists: $\theta = KH_a$. The constant, K, relates the axial rotation to the applied magnetic field, and is expressed in degrees/gauss. The important fact is that

rotations of at least 90 degrees are obtainable in this range. A modulator using this ferrite sample can not be expected to function properly unless its operating point is about 10 gauss, with a maximum signal swing of 10 gauss.

Harmonic distortion results if the modulation signal swings beyond the linear region. It can be shown that harmonic distortion also results when a sinusoidal modulation is applied even if the ferrite modulator is not "overdriven". This is true, since the output of the modulator, assuming ideal ferrite characteristics, is related to the modulation signal, H_a , by the expression

$$E_{out} = E_{in} \sin KH_a \quad (10)$$

where E_{in} is the incident microwave signal. Thus, if the output is to be sinusoidal, H_a must be a linear function of time. The distortion introduced by using a sinusoidal modulating signal will depend upon the magnitude of θ and hence the percent modulation being used. This effect has been observed in most cases. Results of tests performed on the type 1 modulator, for a sinusoidal modulation signal and a sample of Ferramic 1331, are shown in figure 29. The measurement setup used is shown in figure 2.

While the variations in temperature and frequency are large, the harmonic distortion does not seem excessive. On the average, the modulation reaches 90 percent. Before figure 29 was plotted, the operating point and the amplitude of the modulation signal were varied to obtain a minimum harmonic distortion. Variations in the operating point were effected by biasing the unit with magnets. Figure 30 shows the plot of total transmission loss vs frequency, with temperature as a parameter. It is noted that the variation in operating point with frequency and temperature is significant. Similar effects were observed when Ferramic A-106 and D-216 were used (figures 31 and 32), except that, generally, the criteria are not satisfied as well as when Ferramic 1331 is used. The distortion at room temperature is smallest for Ferramic 1331. Note that disagreement between samples can be large (figure 31). The percent harmonic distortion at 9200 mc for various ferrite samples used in the type 1 modulator is given in the following table:

PERCENT POWER HARMONIC DISTORTION (D_p)

FERRITE SAMPLE	HARMONIC	TEMPERATURE		
		-40°F	72°F	150°F
Ferramic 1331 (refer to figure 29)	2nd	10.5	0.9	6.2
	3rd	3.4	5.2	4.2
	4th	0.5	0.4	0.75
Ferramic A-106, Sample No. 1 (refer to figure 31)	2nd	4.0	8.2	10.5
	3rd	5.6	5.5	3.0
	4th	0.6	1.0	2.5
Ferramic A-106, Sample No. 2 (refer to figure 31)	2nd	7.2	8.0	5.4
	3rd	12.1	1.5	1.8
	4th	1.8	0.6	1.5

The applied modulation signal was 50 cps. The upper limit in modulation frequency is primarily determined by the coil impedance and the modulation driving impedance. Relaxation effects may be a factor at high modulation frequencies, but have not been investigated.

c. Ferrite Switch

A ferrite switch can be of two different forms:
 (1) a component that passes or reflects all power incident

upon it, or (2) a component that passes or absorbs all power incident upon it. The advantages of ferrite switches in general, is that they have no moving parts, have switching times faster than conventional switches, and are compact. The switching time is limited by the external switching circuits rather than the ferrite material.

A switch of the first type, hereafter known as the type 1 switch, was built (figure 28). The results of tests performed on this unit using Ferramic 1331 are shown in figure 33. The microwave properties seem satisfactory in view of the reasonable temperature and frequency characteristics, in addition to the particular advantages previously mentioned. It may be observed that the switch exhibits a 28-db differential between "on" and "off" positions (at room temperature). Unfortunately, the ferrite must be degaussed each time; several trials showed only a 15-db differential for the samples that had not been degaussed.

d. Ferrite Attenuator

A ferrite attenuator is a device whose insertion loss depends in some way upon the intensity of the applied magnetic field. The model shown in figure 28 will hereafter be called the type 1 attenuator. Figure 34 shows the results

of tests made on a single unit and on two identical units in series. This data was obtained by means of the automatic measurement setup described in the first interim report. Samples of Ferramic 1331 were used as active elements in each case. Figure 34b shows hysteresis, a_h to be small, amounting to a maximum of approximately 3 db, and an average of 1 db over a range of about 30 db. The spike shown in figure 34b has been observed several times; its cause has not yet been investigated. Figure 34a shows the good agreement between two identical units measured separately.

The match obtained for the single type 1 attenuator gave an average VSWR of two. This match was obtained by placing the ferrite at various positions along the axis in its circular-waveguide housing. Figure 35 shows the change in VSWR as a function of ferrite position for a single unit. Evidently, this parameter is only moderately effective. Plots of VSWR vs frequency and total transmission loss vs frequency, with the ferrite near the position of minimum VSWR, are shown in figures 36 and 37, respectively. Figure 36 shows the variation in VSWR vs frequency for the two values of applied magnetic field at which the total transmission loss is a maximum and minimum. For the same conditions, figure 37 shows the variation in total transmission loss vs frequency.

For example, zero at the ordinate in figure 37 represents a 1.5-db minimum transmission loss for the one curve and a 32-db maximum transmission loss for the other. The VSWR never exceeds three over the band, and the maximum variation in a_t is approximately ± 3 db over the entire operating range and frequency band.

10. PROJECT PERFORMANCE AND SCHEDULE

See figure 38 for a chart showing the project performance and schedule.

SECTION D
CONCLUSIONS

11. CONCLUSIONS

The data obtained on several types of ferrites indicate that Ferramics A-106 and 1331 have the lowest ferrite absorption loss, and that both ferrites are good rotators. In addition, Ferramic A-106 has characteristics which follow a predictable pattern, making it adaptable to component development. With proper broadbanding techniques, Ferramic 1331, with its low absorption loss, should also be readily adaptable to component development.

Ferrite-loaded rectangular waveguide located in an applied transverse magnetic field exhibits either reciprocal or nonreciprocal properties (determined by the location of the ferrite in the waveguide). Several interesting possibilities are suggested by the curves in figure 26. The non-reciprocal properties illustrated define a unidirectional component with a loss differential of approximately 37 db and a VSWR of 1.15 at 9000 mc. This same curve contains a region of a_t and H_a in which a power modulator, attenuator, or switch may well be designed. A preliminary test showed the hysteresis to be very small. The difficulty is that

with the present ferrites the magnet size required to obtain the fields needed is much too large for component use.

The type 1 modulator exhibited a modulation capability of 90 percent with an rms harmonic distortion (D_p) of 5 percent at room temperature. Ferramic 1331 is superior to Ferramics A-106 and D-216 in this application.

The type 1 switch exhibited a change in attenuation from 1 to 29 db. Hysteresis effects, however, can amount to a 10-db change unless the ferrite is degaussed between trials.

Two type 1 attenuators in series had an average hysteresis of 1 db and a maximum of 3 db. The range of this combination extends from 8 db to approximately 30 db, whereas the single unit has a range of 4 db to 23 db. More accurate measurements using a heterodyne precision measurement setup showed the range to extend above 50 db for two units in series. On the basis of the tests on the two units, reproducibility is within approximately 1 db.

In general, the study of the broadbanding problem has been postponed until more progress is made in initial developments.

PART II
PROGRAM FOR NEXT INTERVAL

12. PROGRAM FOR THE THIRD INTERIM

a. Research Phase

In the research phase additional tests will be made to determine any changes in ferrite absorption loss due to the absorption of water vapor by the ferrite samples. Also, data will be obtained on the microwave properties of ferrites in circular waveguide as a function of frequency and temperature. Tests on ferrites in rectangular waveguide located in an applied transverse magnetic field will continue. Determination of the effect of temperature on the microwave properties of ferrites in rectangular waveguide will be made.

b. Development Phase

The development program will consist of improving existing designs and investigating new techniques. Further checks will be made on the type 1 attenuator.

The design implications of the unidirectional characteristics of ferrites in rectangular waveguide shown

in figure 26b will be investigated for application to devices for modulation, attenuation, switching, and non-reciprocal transmission.

Studies of broadbanding devices will be initiated.

PART III

APPENDIX

13. EQUIPMENT REQUIRED FOR PRECISION MEASUREMENT SETUP
USED FOR STUDIES IN RECTANGULAR WAVEGUIDE

The following list of items and item numbers refer directly to figure 1:

- 1 Sperry Microline^R Klystron Signal Source, Model 555
- 2 Sperry Klystron, 2K39
- 3 Sperry Variable Attenuator, Model 152
- 4 Sperry Cavity Frequency Meter, Model 273
- 5 Sperry Impedance Meter, Model 145 with R-F Head
- 6 Sperry Directional Coupler, Model 235
- 7 Ferrite Cell, Consisting of 5" length of X-band waveguide in traverse magnetic field
- 8 Sperry Termination, Model 150
- 9 Sperry Adapter, Model 167-A
- 10 Sperry Mixer, Model 379
- 11 Sperry Microline Receiver, Model 296-A (used with a preamplifier)
- 12 Weston D-C Ammeter, Model 430
- 13 Rheostats for varying magnet-coil current

14. EQUIPMENT REQUIRED FOR MODULATION MEASUREMENTS

The following list of items and item numbers refers directly to figure 2.

- 1 Sperry Microline Klystron Signal Source, Model 555
- 2 Sperry Klystron, 2K39
- 3 Sperry Adaptor, Model 486
- 4 Sperry Attenuator, Model 152A
- 5 Sperry Frequency Meter, Model 126
- 6 Sperry Barretter Mount, Model 184
- 7 Sperry Wattmeter Bridge, Model 123B
- 8 Sperry Crystal Detector, Model 360-H
- 9 DuMont Oscilloscope, Model 304-H
- 10 Hewlett-Packard Audio Oscillator, Model 400C
- 11 General Radio Harmonic Analyzer, Type 736A
- 12 Sperry Directional Coupler, Model 235

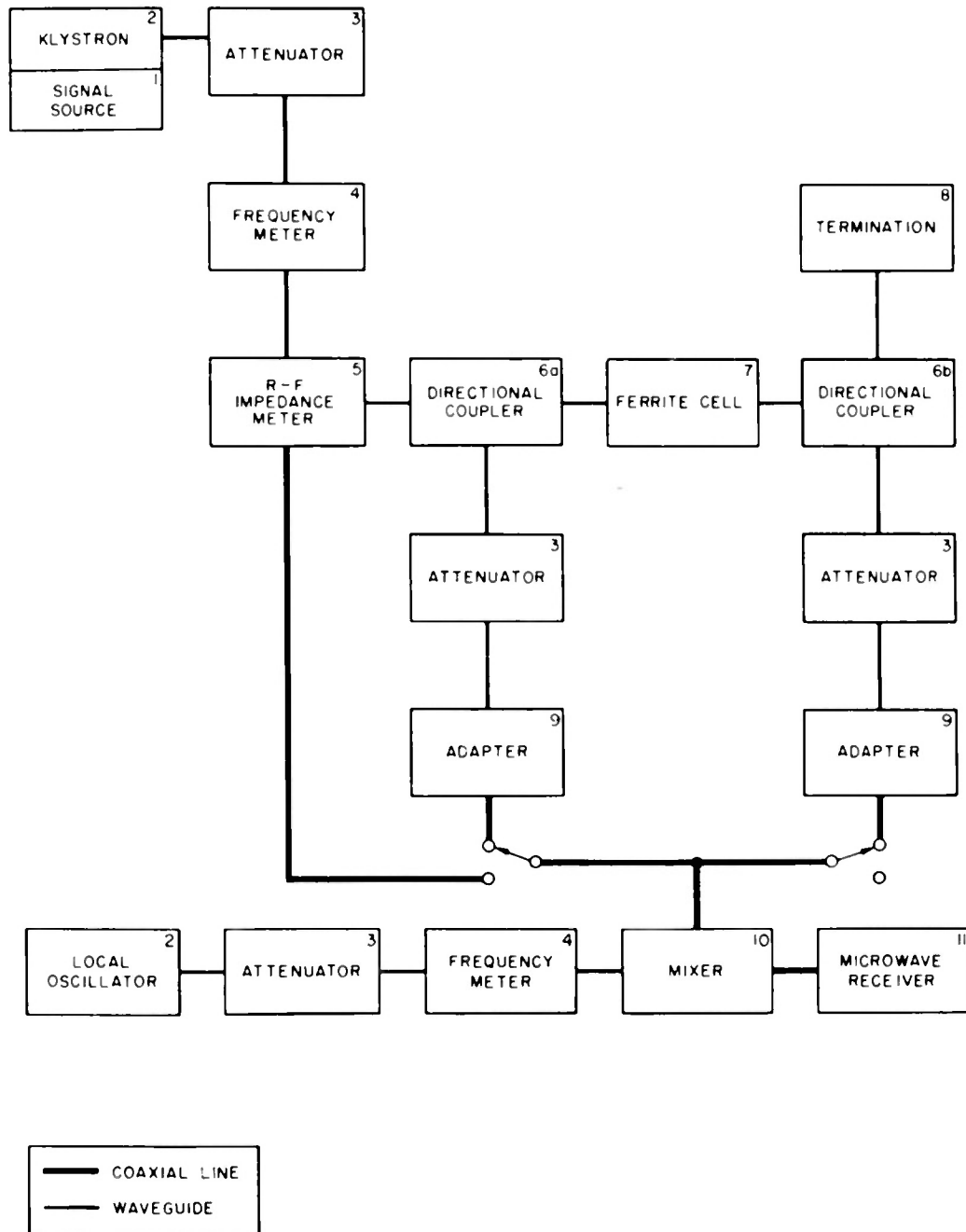

FIGURE 1
PRECISION MEASUREMENT SETUP
USED FOR STUDIES IN
RECTANGULAR WAVEGUIDE

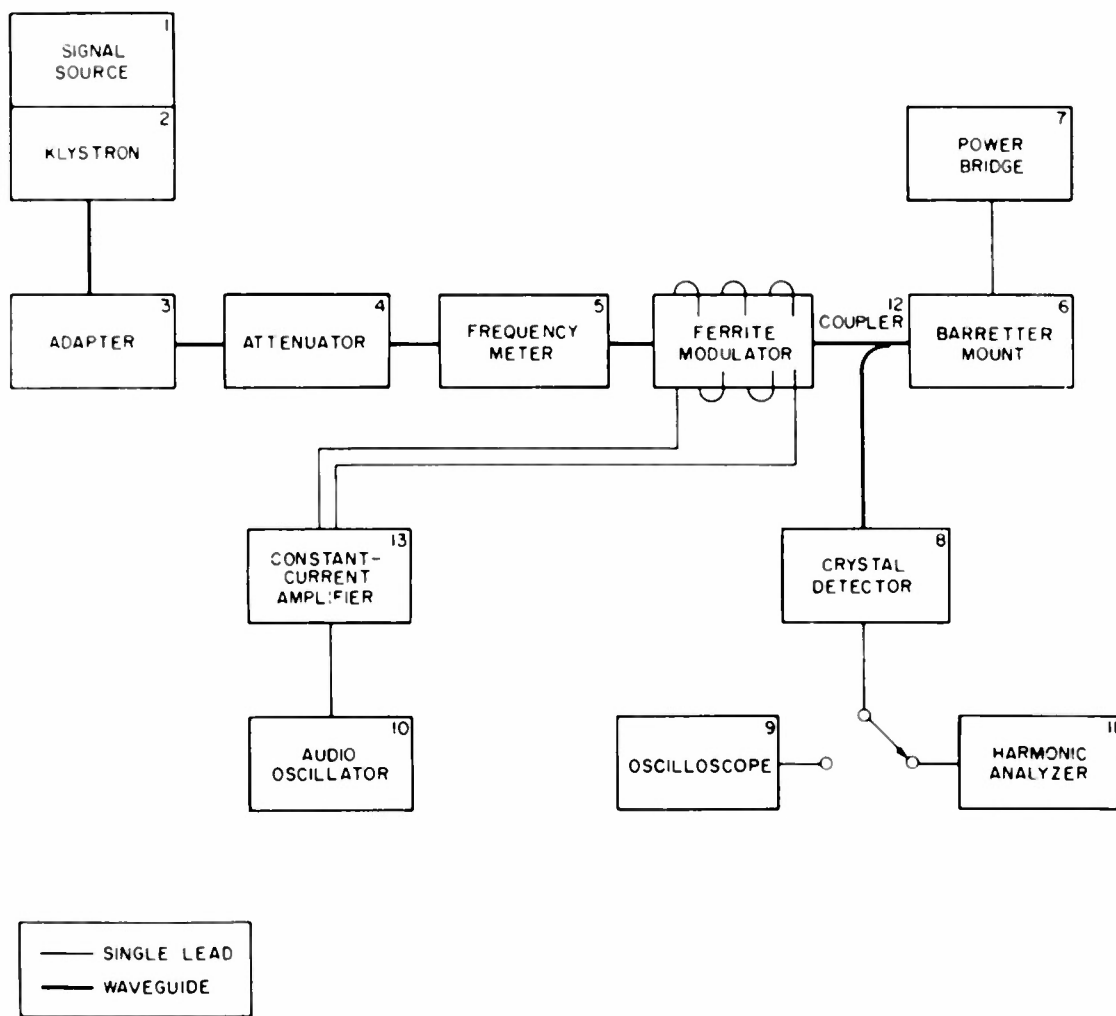
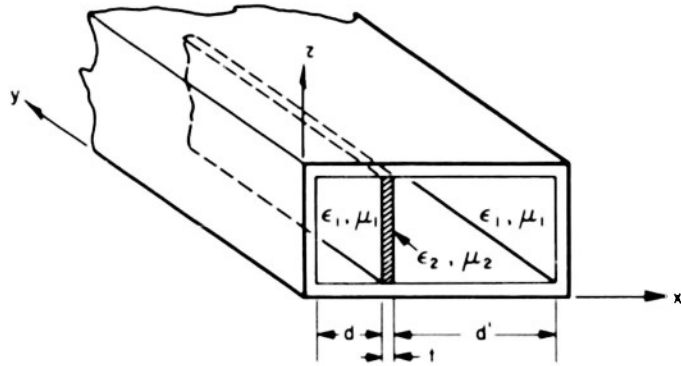
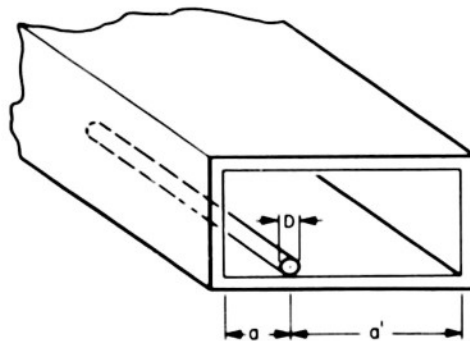

FIGURE 2
MEASUREMENT SETUP USED TO
DETERMINE PERCENT MODULATION



(a) FERRITE SLAB IN RECTANGULAR WAVEGUIDE



(b) FERRITE CYLINDER IN RECTANGULAR WAVEGUIDE

FIGURE 3
FERRITES IN
RECTANGULAR WAVEGUIDE

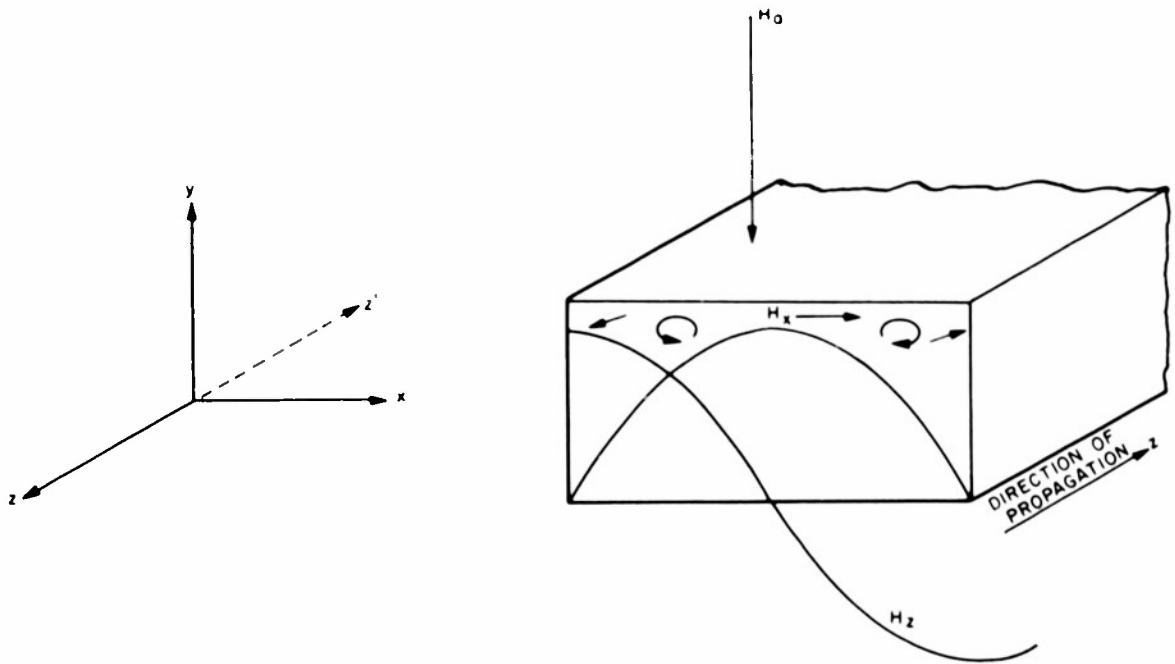
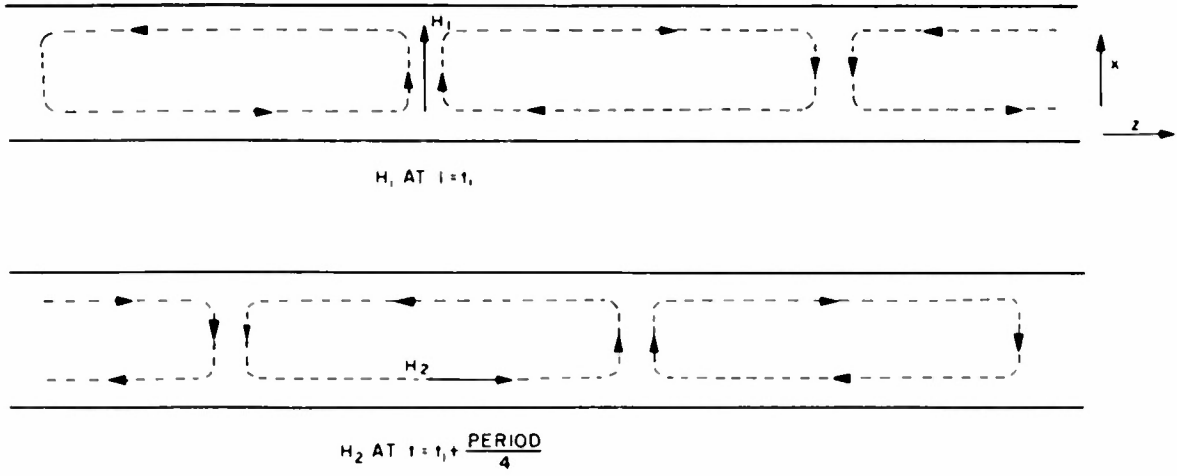
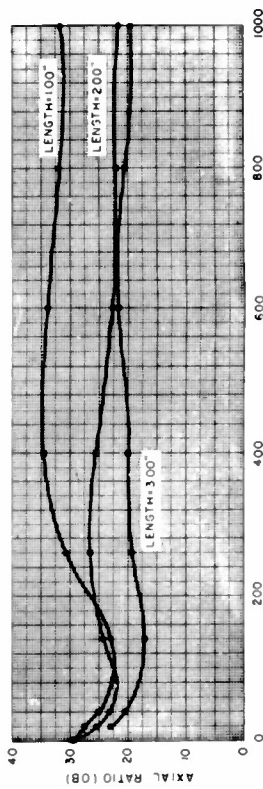
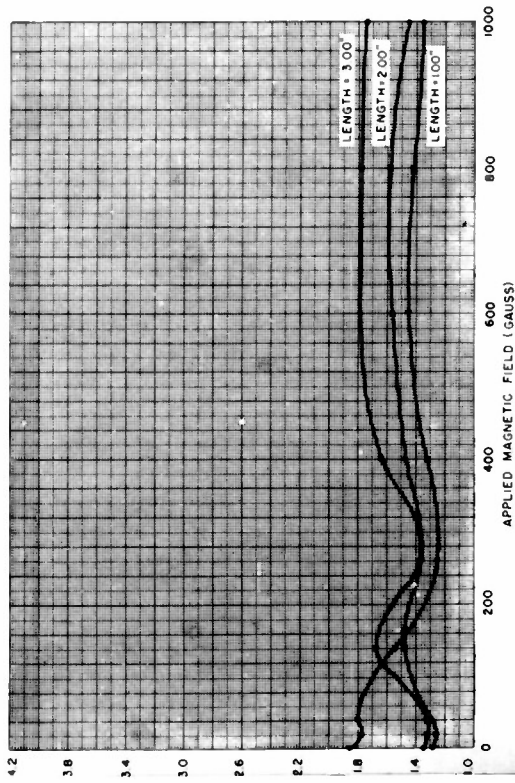
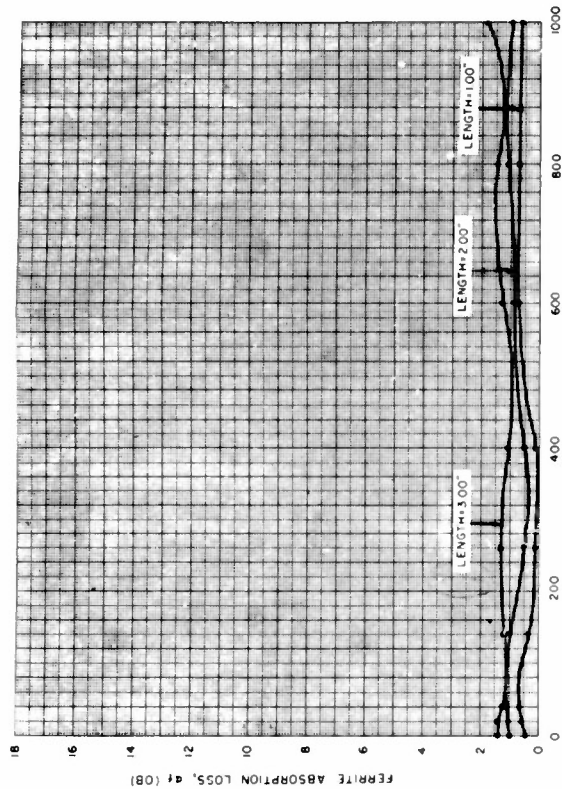
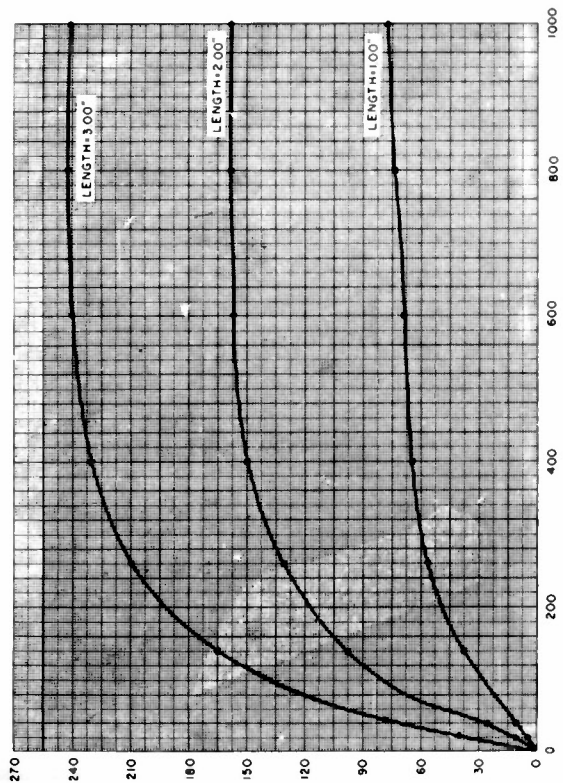

FIGURE 4
MAGNETIC FIELD IN
RECTANGULAR WAVEGUIDE
FOR TE_{10} MODE



APPLIED MAGNETIC FIELD (GAUSS)

TEMPERATURE = 23°C (73°F)
FREQUENCY = 9600 MC
DIAMETER = 0.262"

FIGURE 5
MICROWAVE PROPERTIES OF FERRIMIC A-1
WITH LENGTH AS PARAMETER

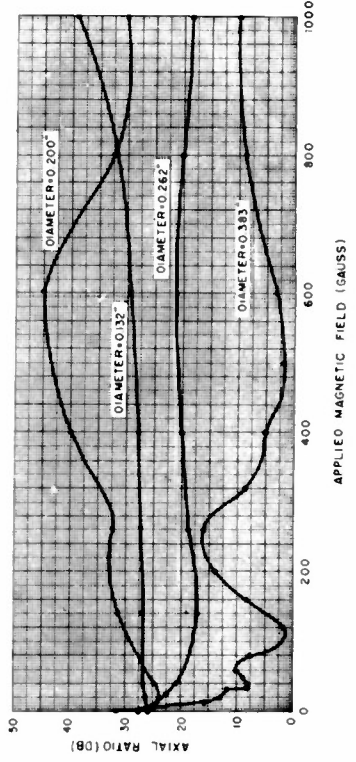
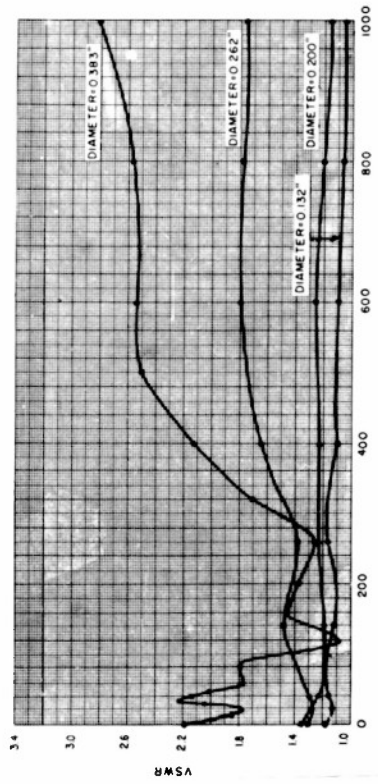
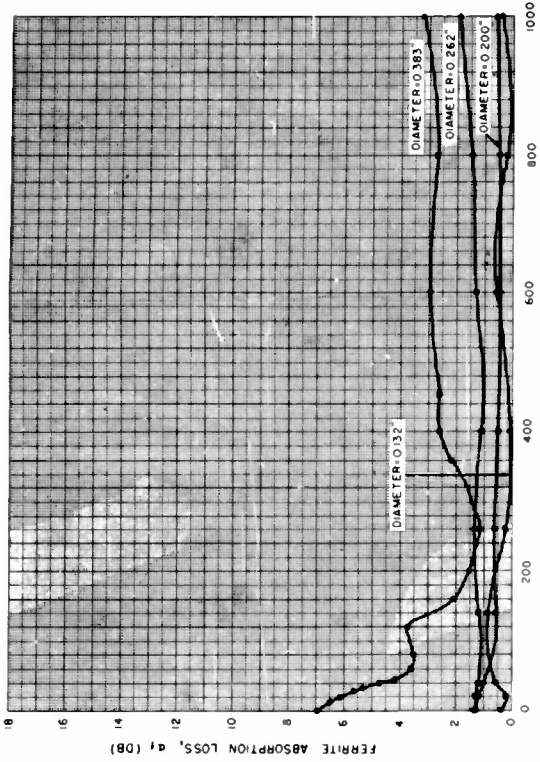
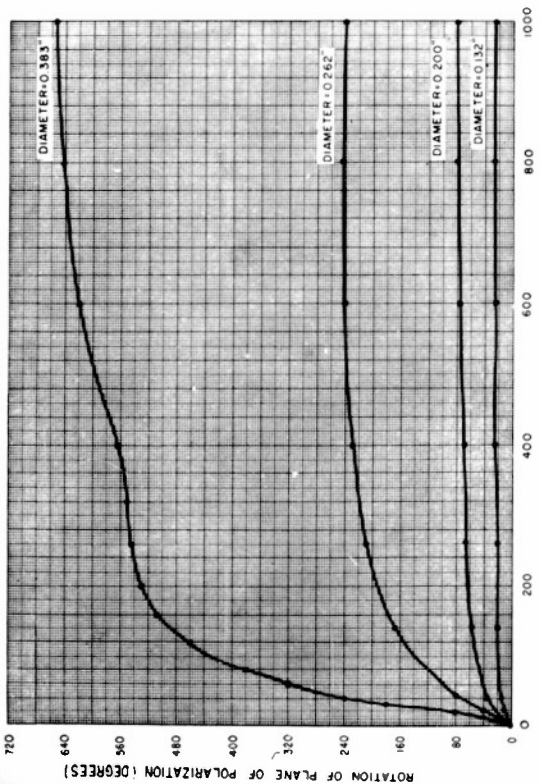
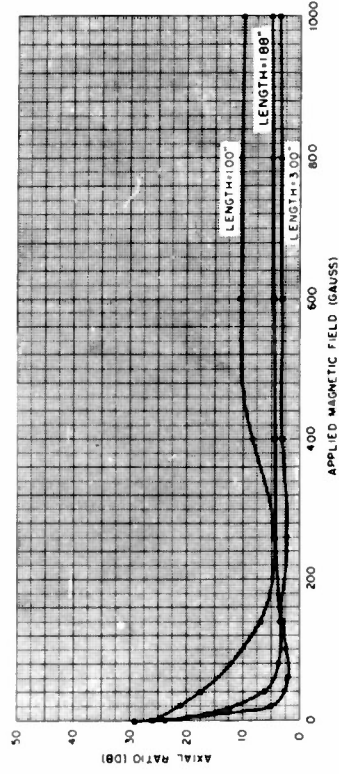
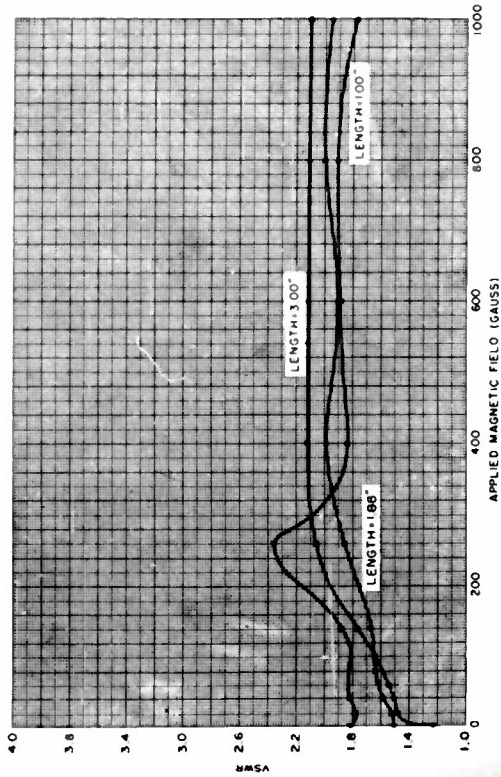
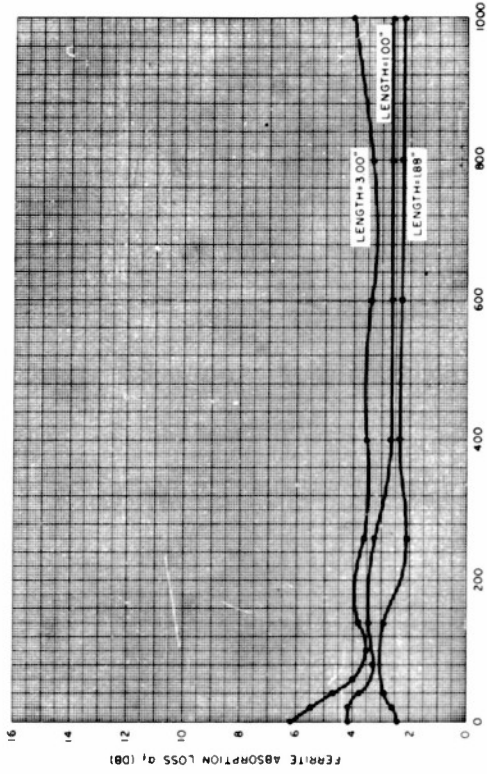
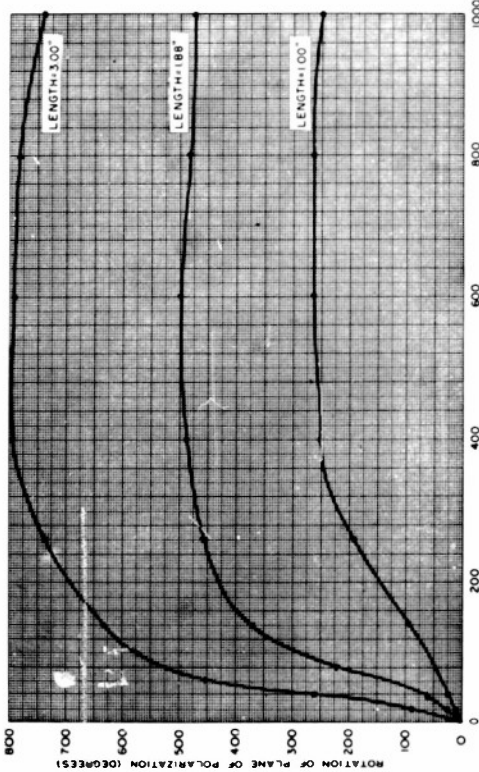

FIGURE 6
MICROWAVE PROPERTIES OF FERRIMIC A-106,
WITH DIAMETER AS PARAMETER

TEMPERATURE = 21°C (73°F)
FREQUENCY = 9600 MC
LENGTH = 3.00"



TEMPERATURE = 23°C (73°F)
FREQUENCY = 9600 MC
DIAMETER = 0.266"

FIGURE 7
MICROWAVE PROPERTIES OF FERRIMIC B-9
WITH LENGTH AS PARAMETER

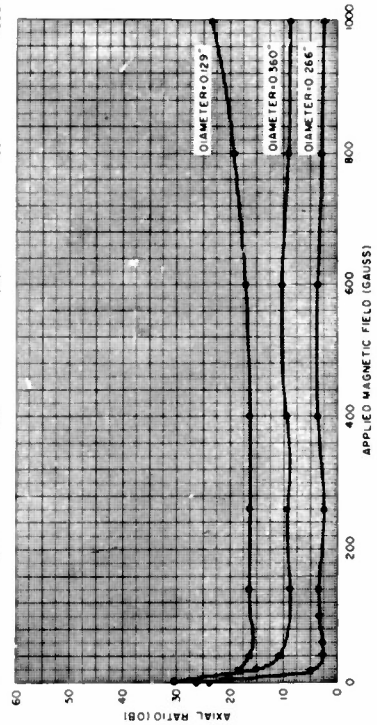
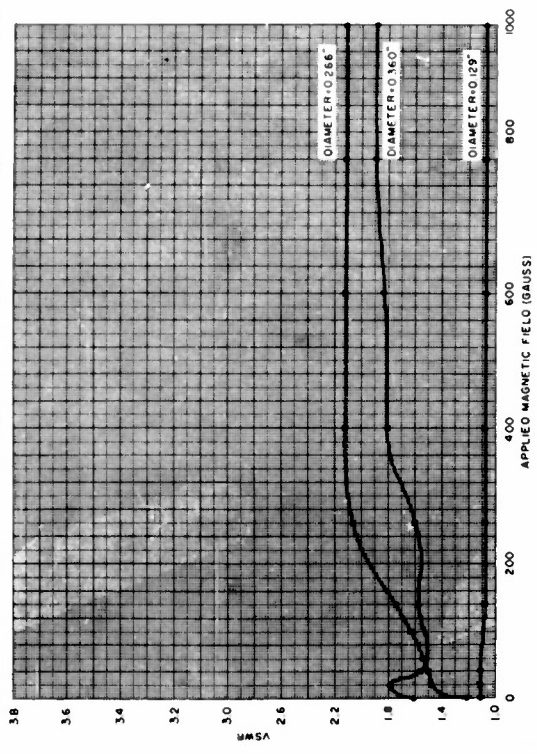
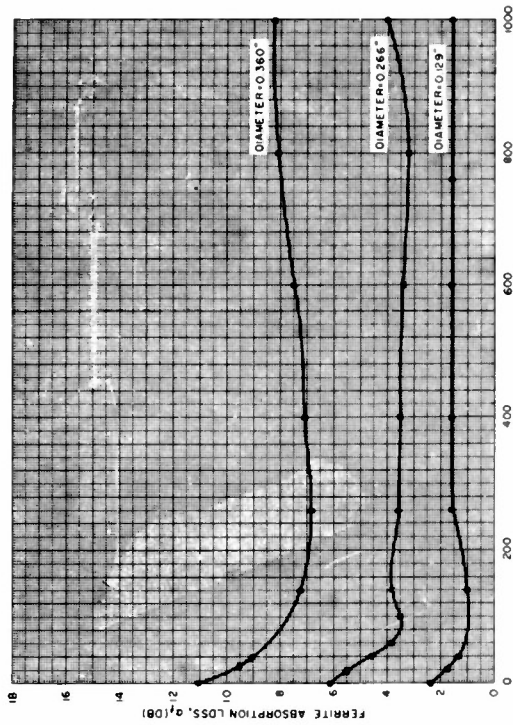
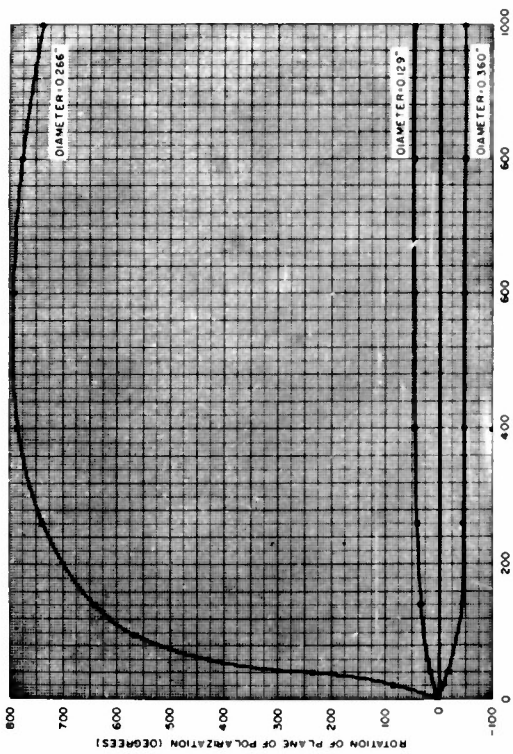

FREQUENCY * 9600 MC
TEMPERATURE * 23°C (73°F)
LENGTH * 3.00"

FIGURE B
MICROWAVE PROPERTIES OF FERRIMIC B-90,
WITH DIAMETER AS PARAMETER

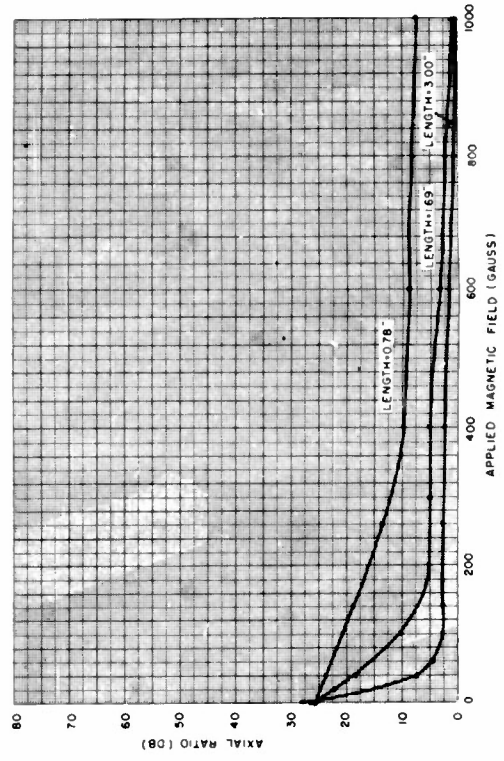
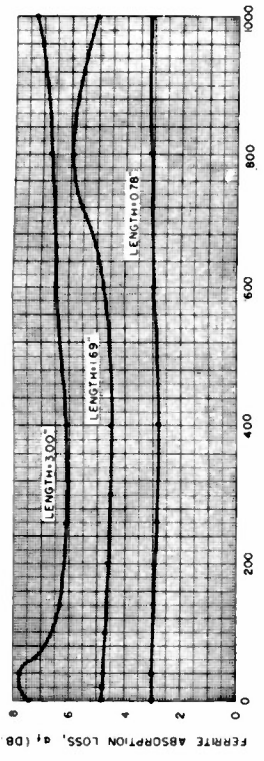

TEMPERATURE = 23°C (73°F)
FREQUENCY = 9600 MC
DIAMETER = 0.246"

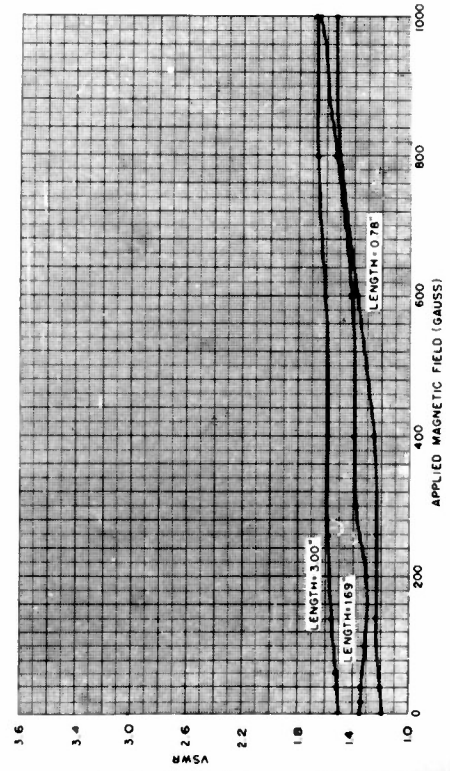
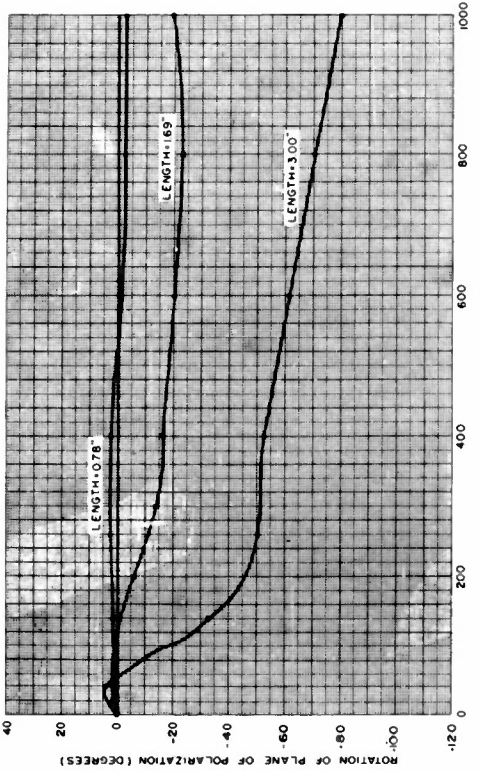
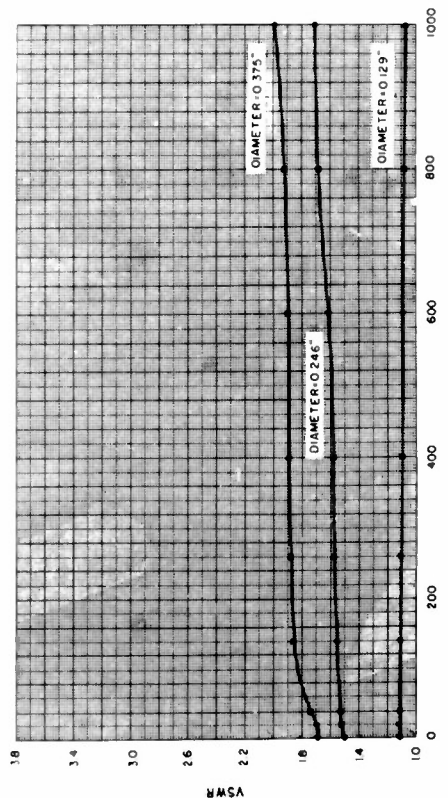
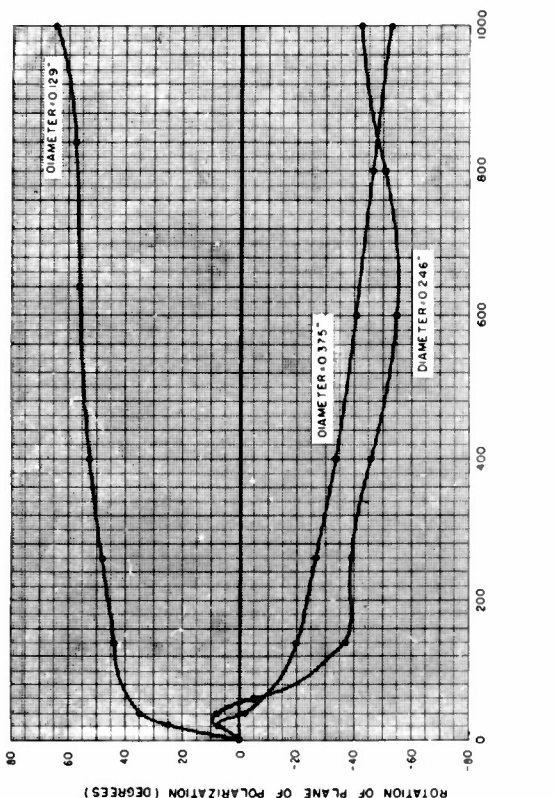
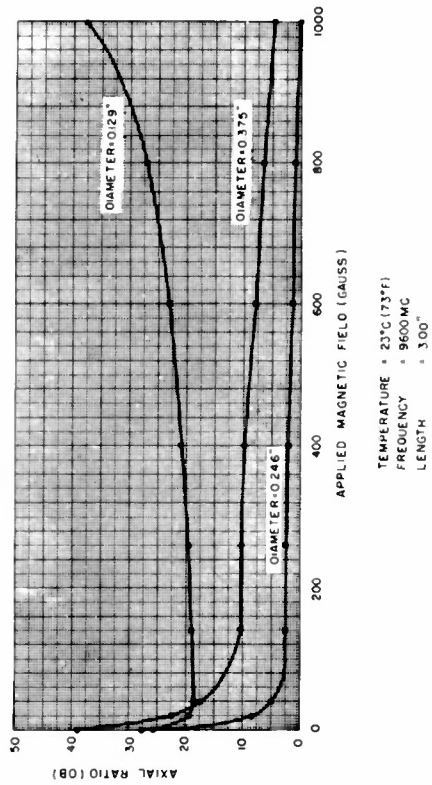
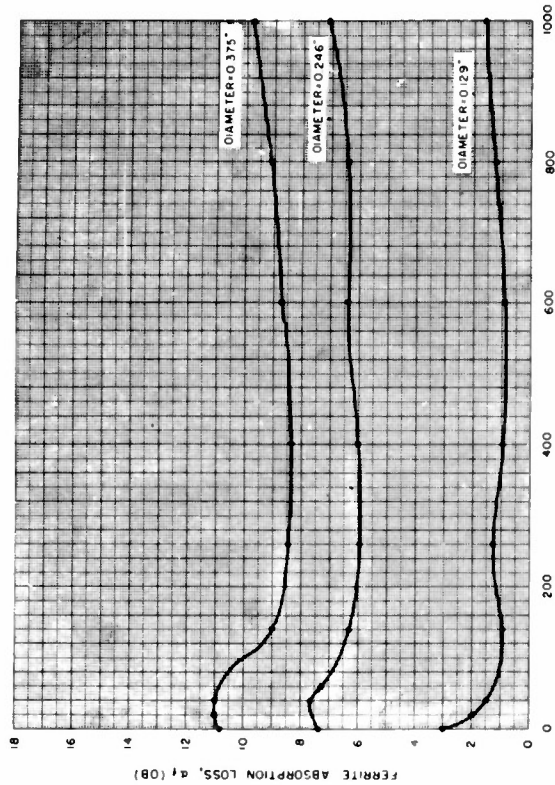

FIGURE 9
MICROWAVE PROPERTIES OF FERRIMIC C-159
WITH LENGTH AS PARAMETER



TEMPERATURE = 23°C (73°F)
FREQUENCY = 9600 MC
LENGTH = 3.00"

FIGURE 10
MICROWAVE PROPERTIES OF FERRIMIC C-159
WITH DIAMETER AS PARAMETER

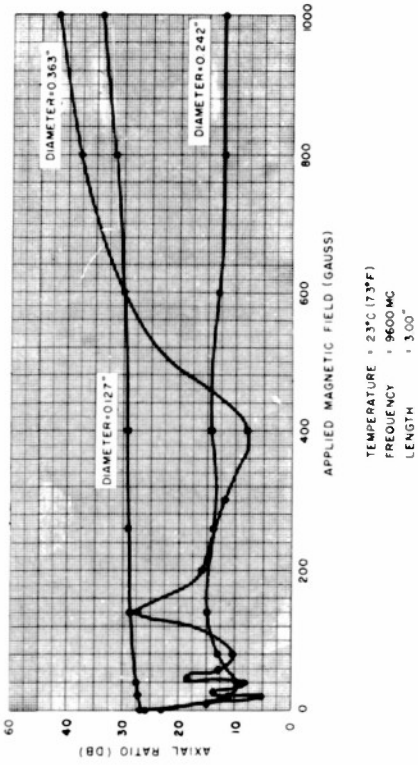
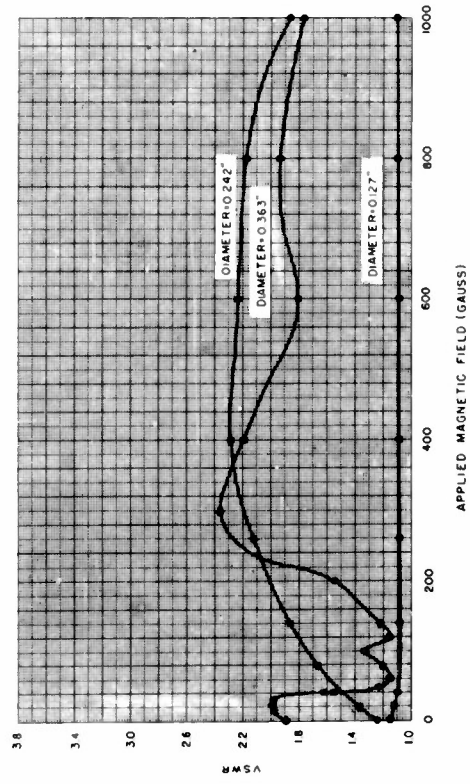
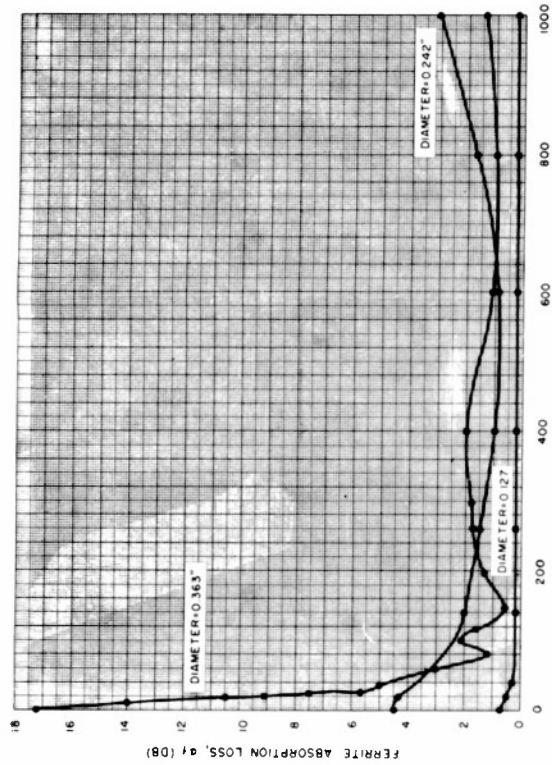
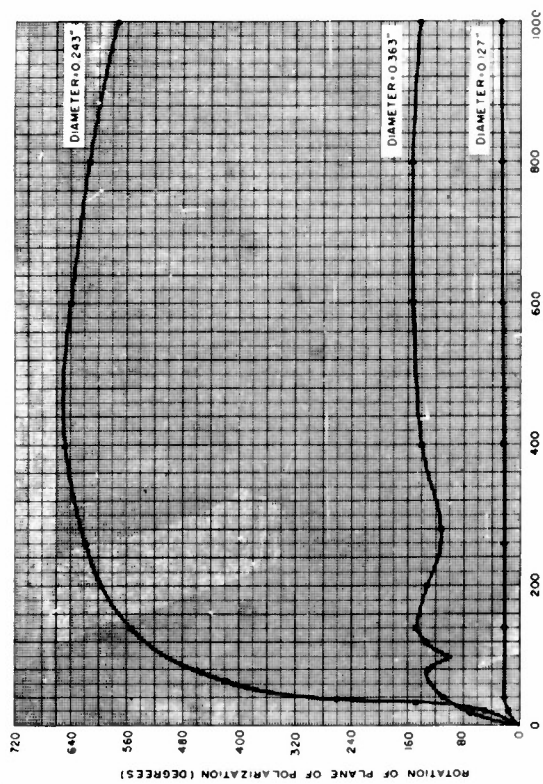
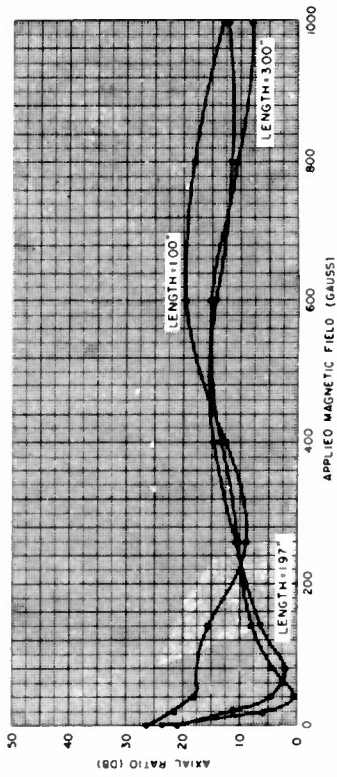
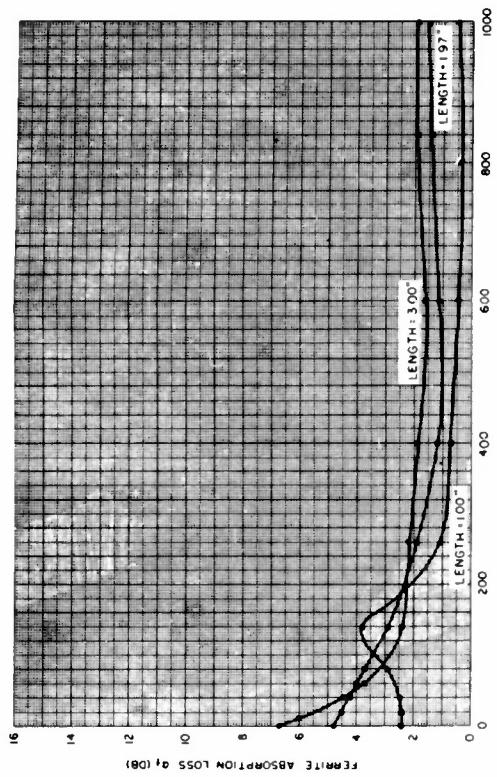

FIGURE 11

MICROWAVE PROPERTIES OF FERRIMIC O-2 WITH DIAMETER AS PARAMETER

TEMPERATURE = 23°C (73°F)
FREQUENCY = 9600 MC
LENGTH = 3.00"



TEMPERATURE = 23°C (73°F)
FREQUENCY = 9600 MC
DIAMETER = 0.241"

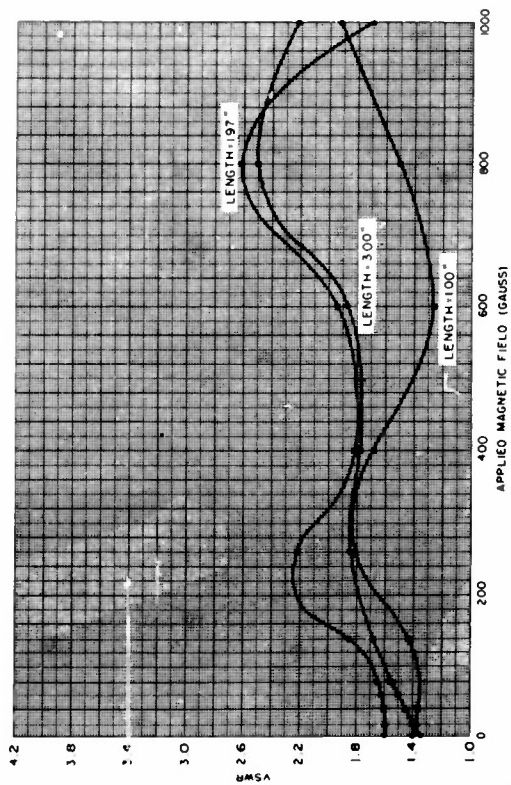
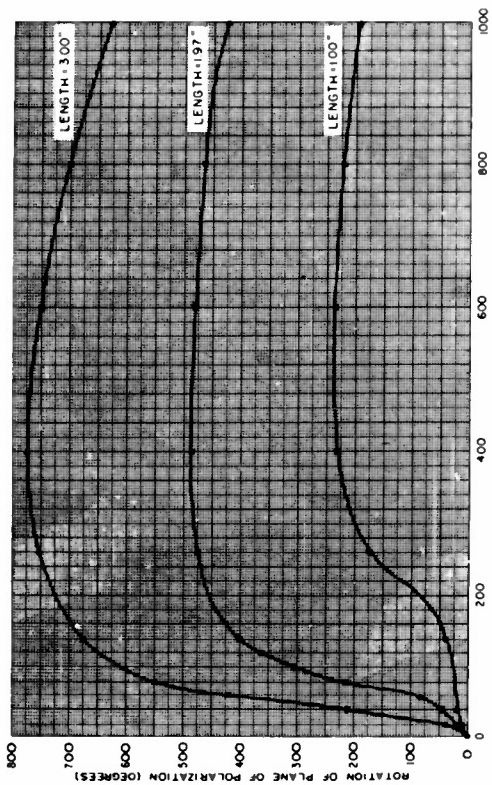
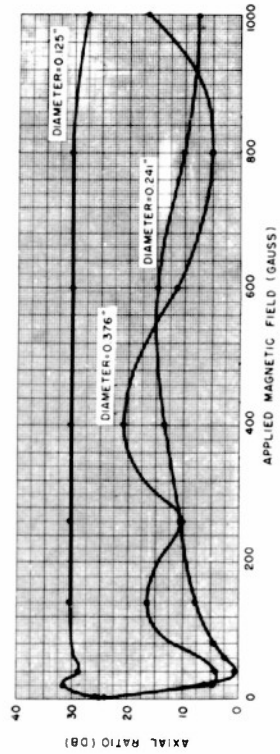
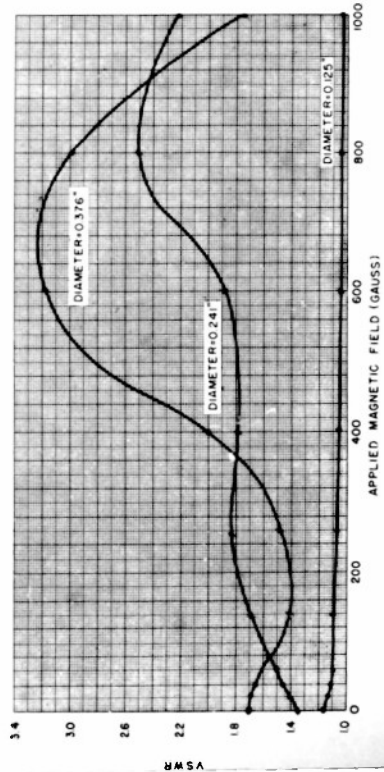
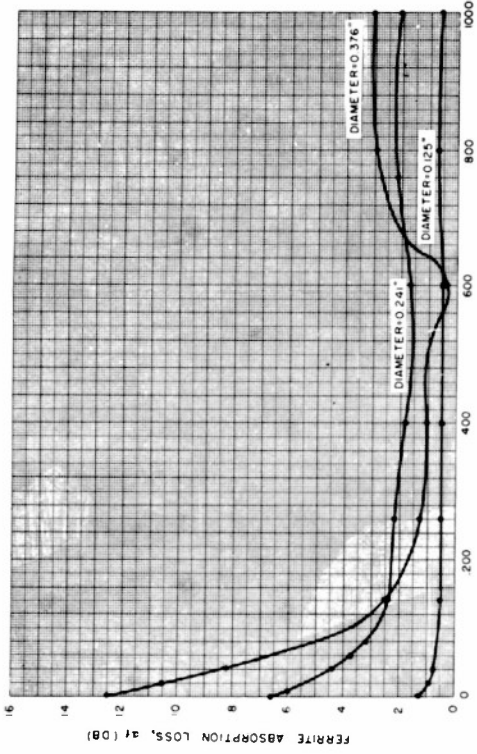
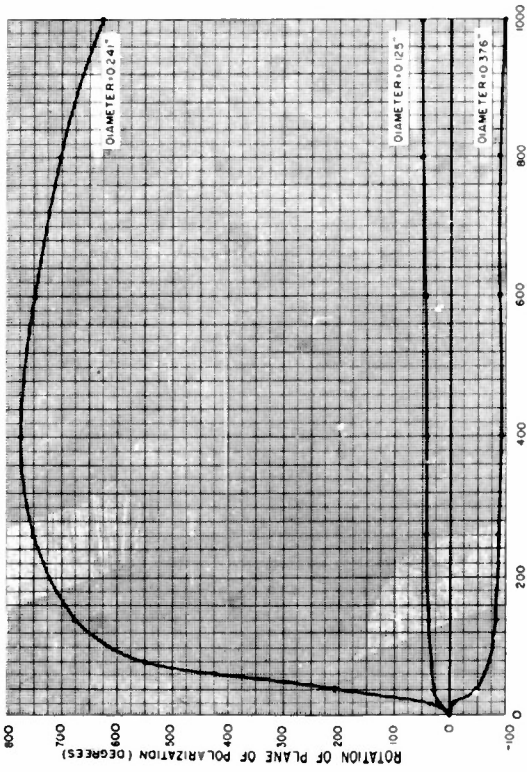
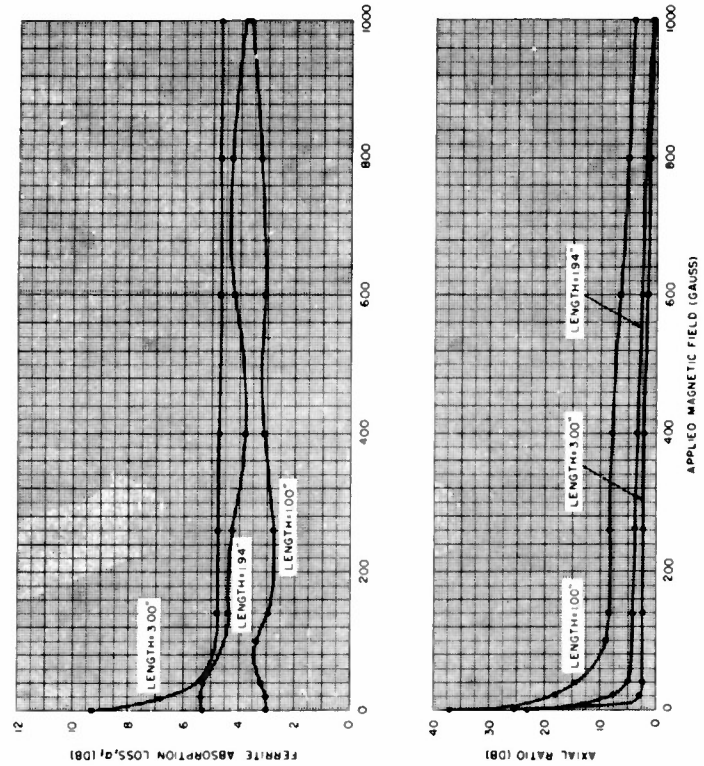

FIGURE 12
MICROWAVE PROPERTIES OF FERRIMIC G-25
WITH LENGTH AS PARAMETER



TEMPERATURE = 23°C (73°F)
FREQUENCY = 9600 MC
LENGTH = 300"

FIGURE 13
MICROWAVE PROPERTIES OF FERRIMIC G-254,
WITH DIAMETER AS PARAMETER



TEMPERATURE = 23°C (73°F)
FREQUENCY = 9600 MC
DIAMETER = 0.249"

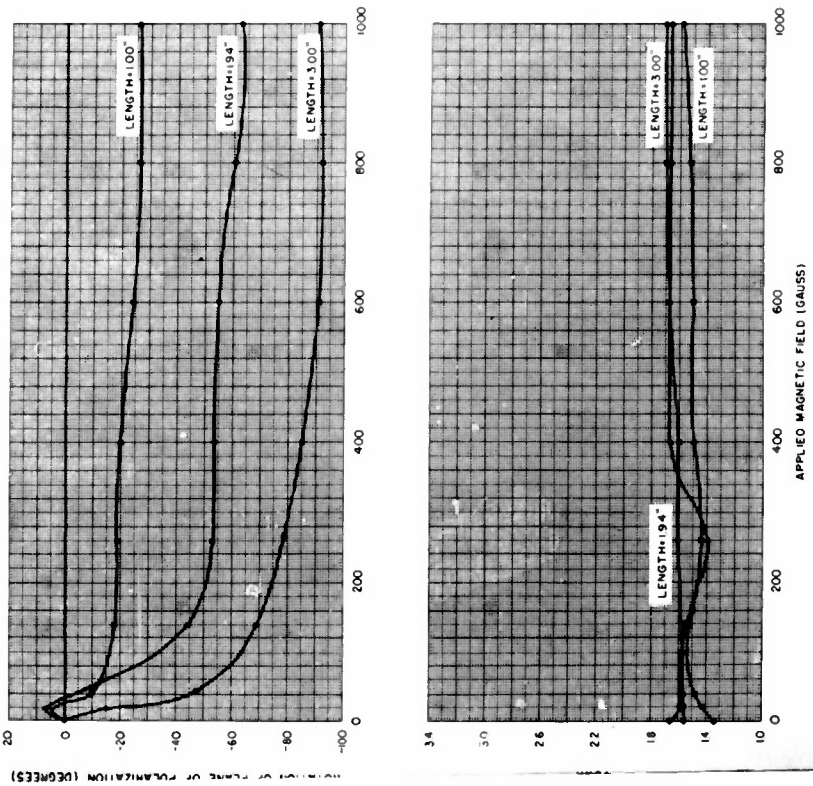
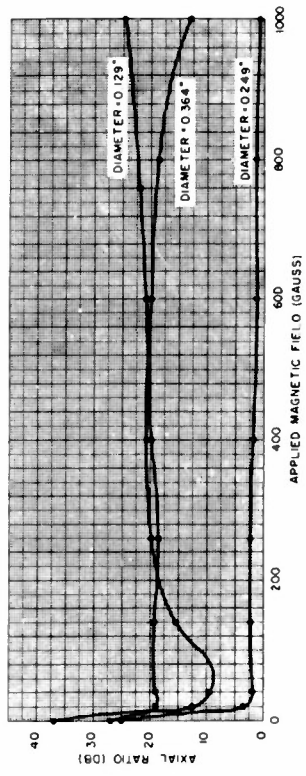
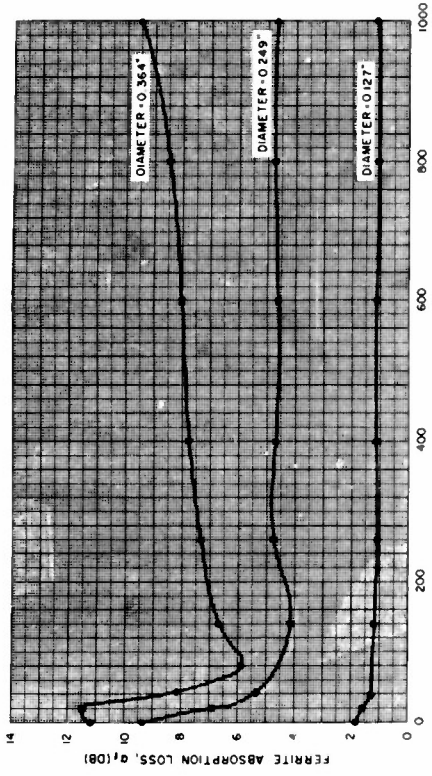

FIGURE 14
MICROWAVE PROPERTIES OF FERRIMIC N-419,
WITH LENGTH AS PARAMETER



FREQUENCY - 9600 MC
 TEMPERATURE - 23°C (73°F)
 LENGTH - 3.00"

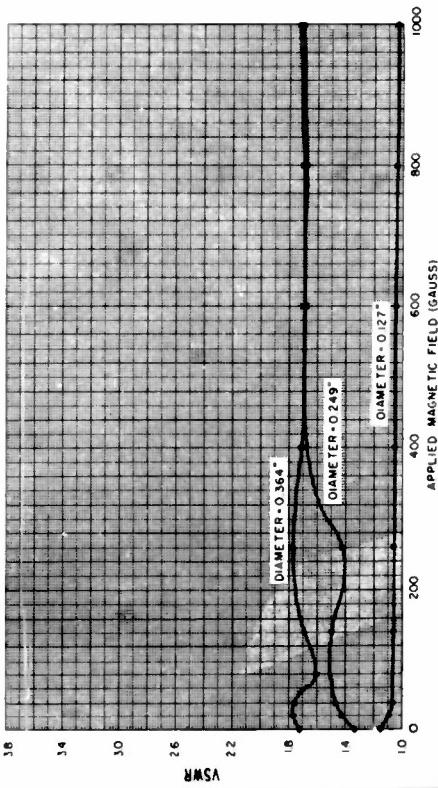
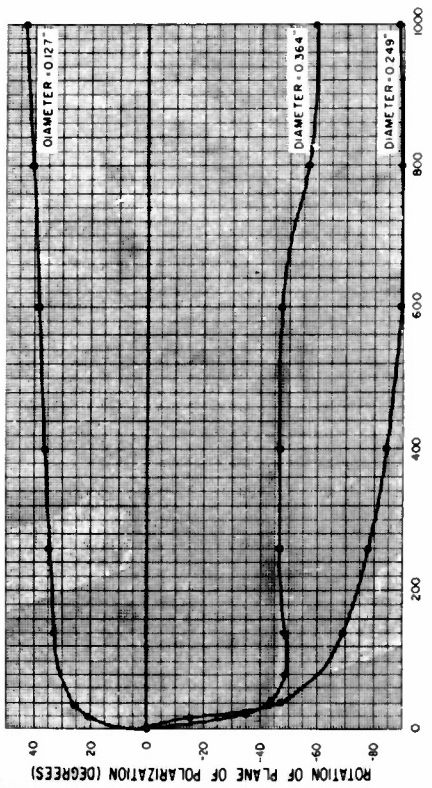
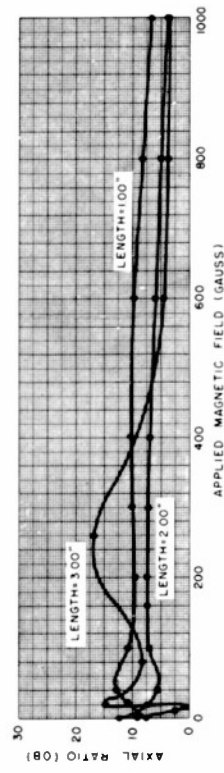
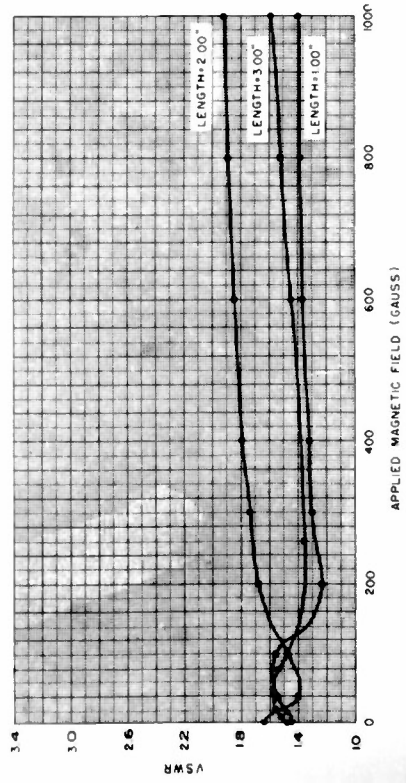
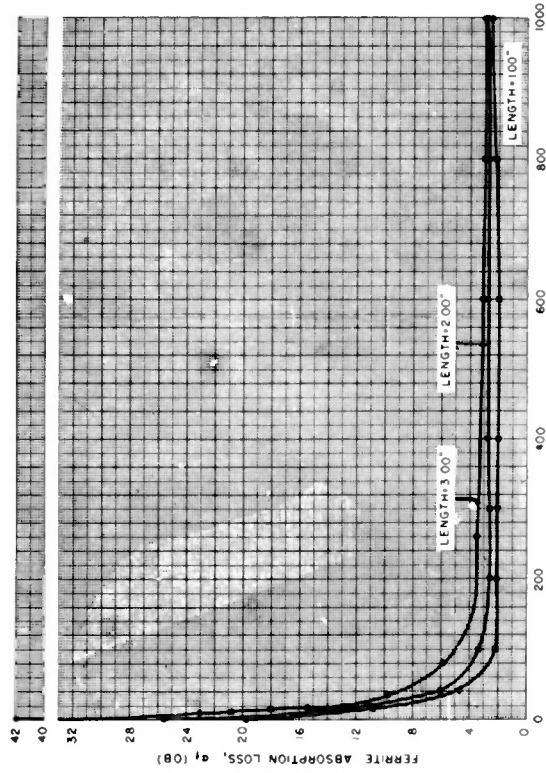
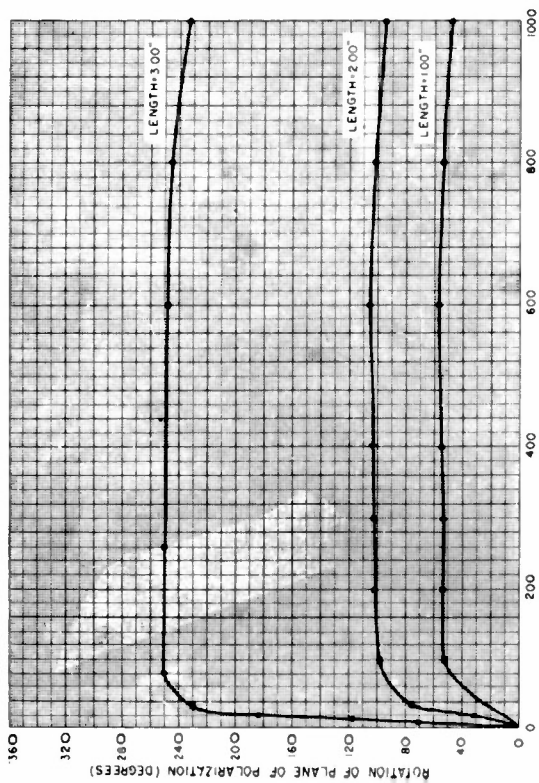

FIGURE 15
 MICROWAVE PROPERTIES OF FERRIMIC H-419
 WITH DIAMETER AS PARAMETER



TEMPERATURE = 23°C (73°F)
FREQUENCY = 9600 MC
DIAMETER = 0.250"

FIGURE 16
MICROWAVE PROPERTIES OF FERRIMIC I-14,
WITH LENGTH AS PARAMETER

Handwritten marks: a checkmark and a squiggle.

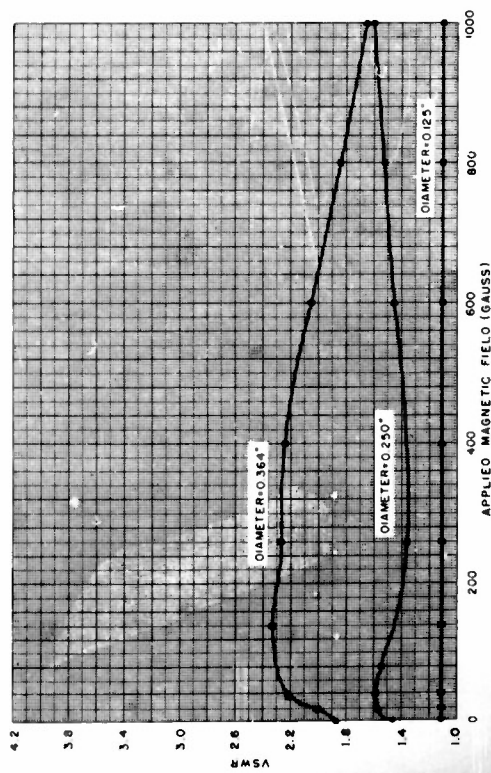
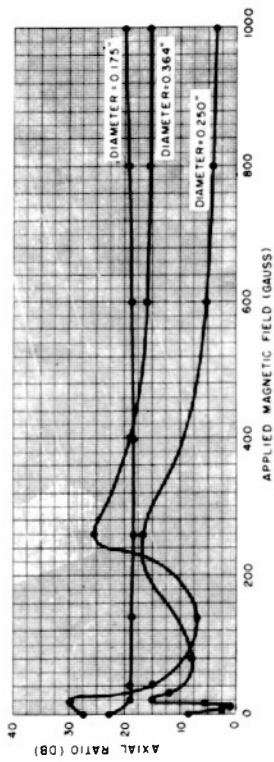
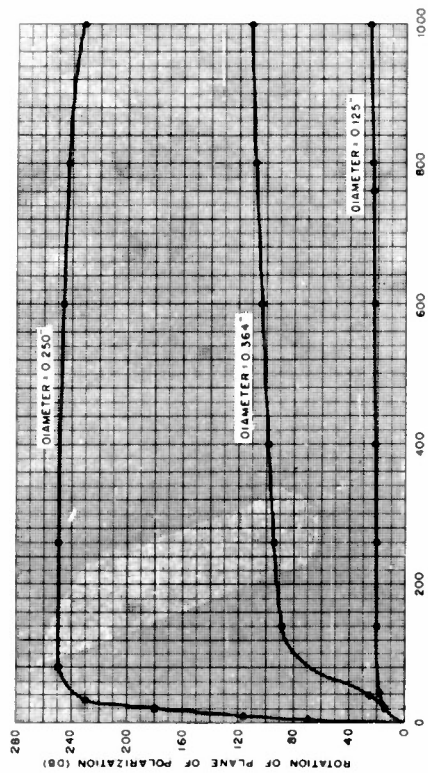
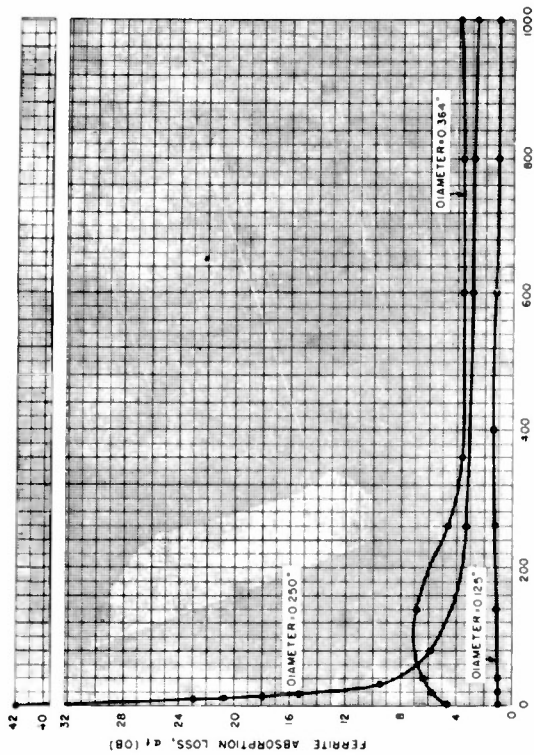

TEMPERATURE = 23°C (73°F)
 FREQUENCY = 9600 MC
 LENGTH = 3.00"

FIGURE 17

MICROWAVE PROPERTIES OF FERRIMIC 1-141
 WITH DIAMETER AS PARAMETER

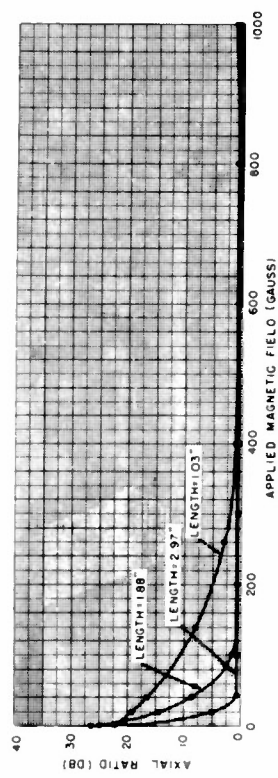
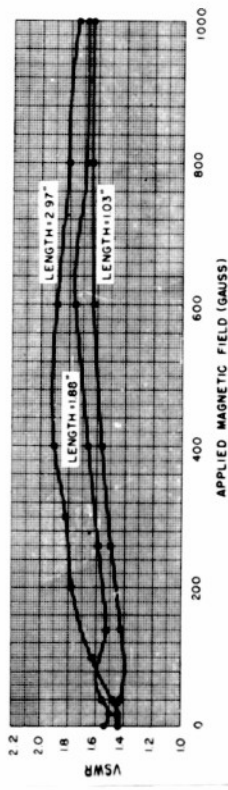
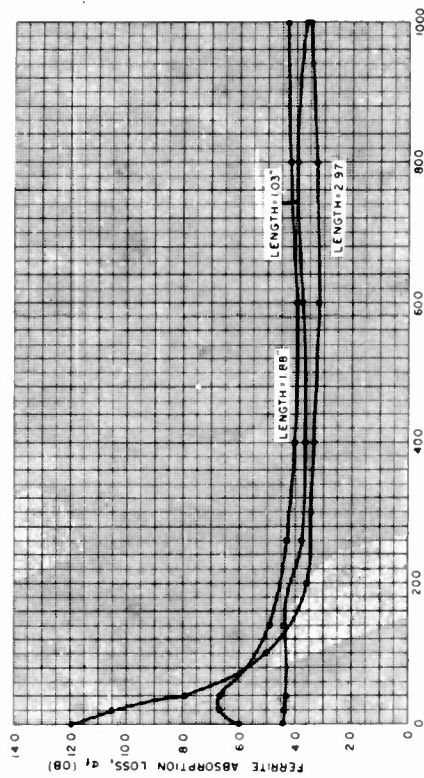
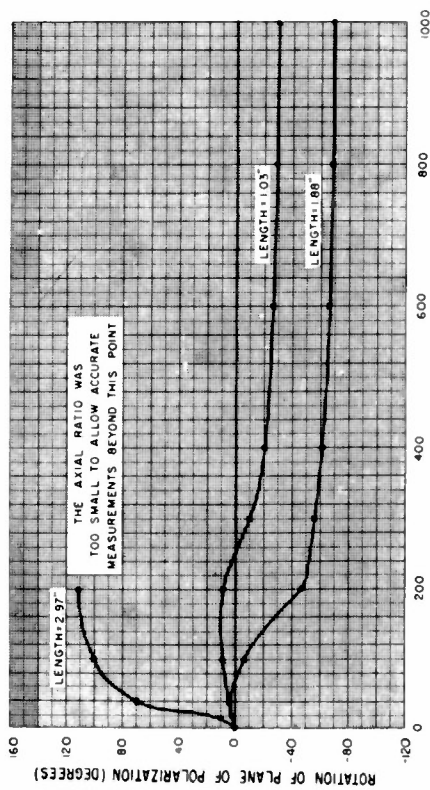

TEMPERATURE = 23°C (73°F)
FREQUENCY = 9600 MC
DIAMETER = 0.242"

FIGURE 18
MICROWAVE PROPERTIES OF FERRIMIC J-472,
WITH LENGTH AS PARAMETER

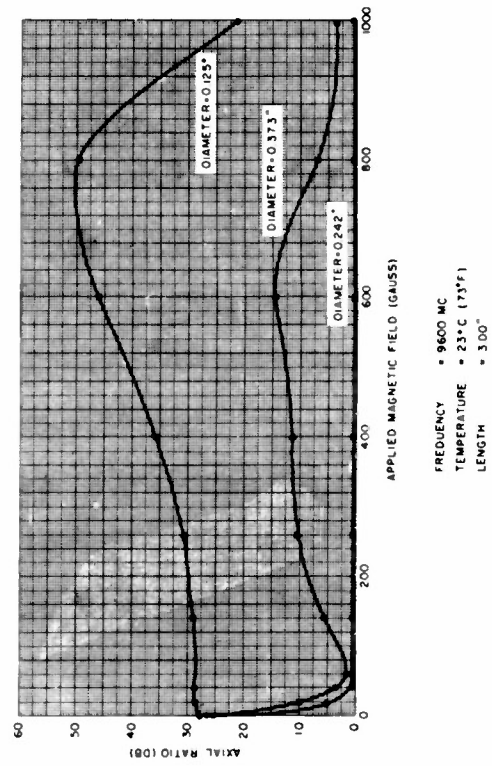
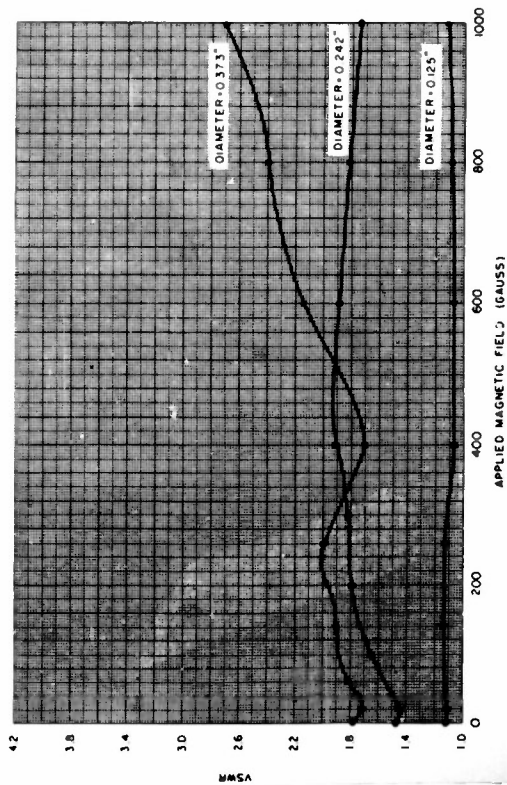
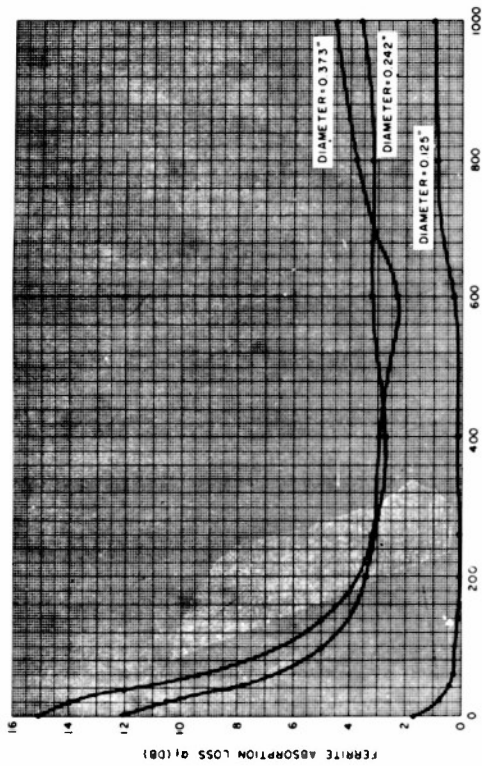
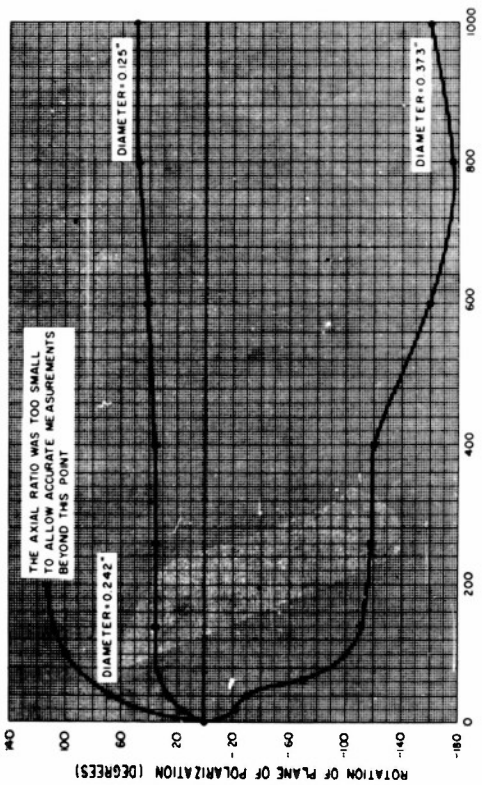

FREQUENCY = 9600 MC
TEMPERATURE = 23°C (71°F)
LENGTH = 3.00"

FIGURE 19
MICROWAVE PROPERTIES OF FERRIMIC J-472
WITH DIAMETER AS PARAMETER

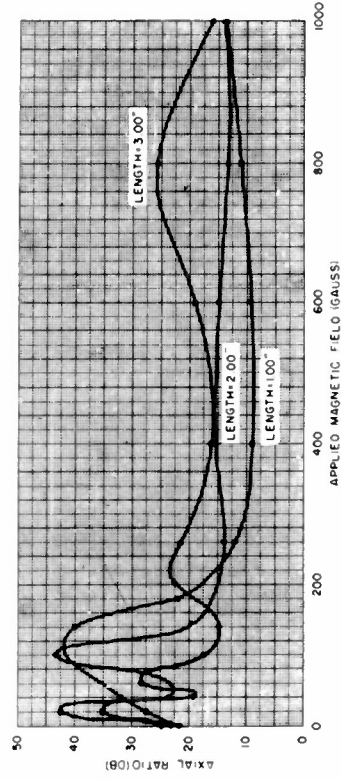
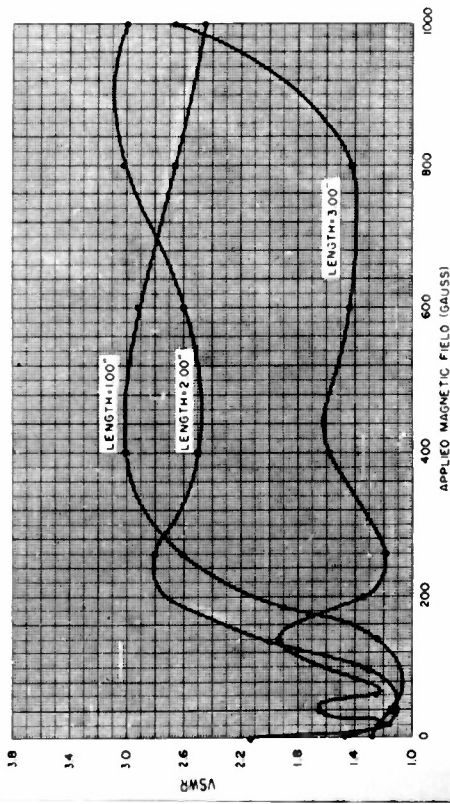
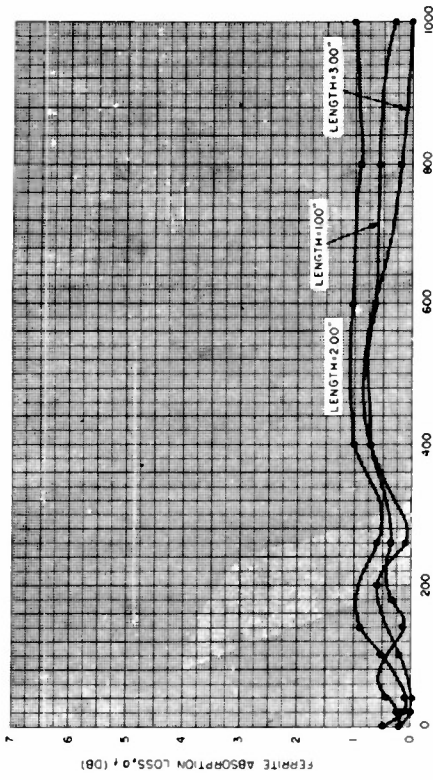
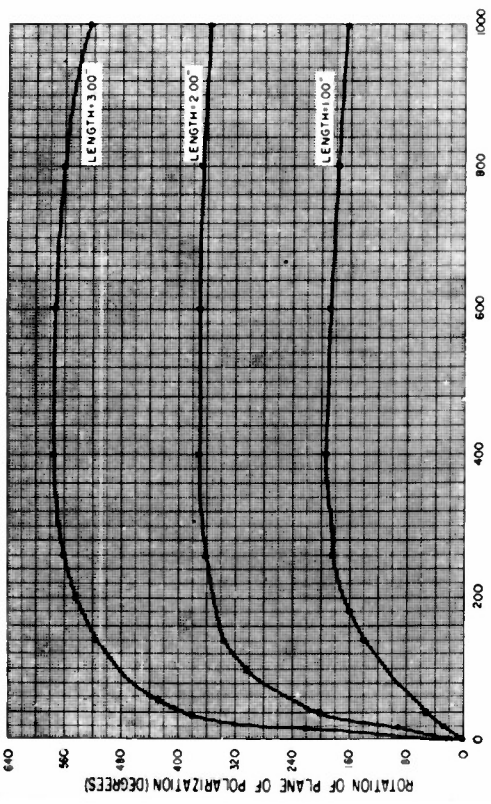

TEMPERATURE 123°C (173°F)
FREQUENCY 19600 MC
DIAMETER 1.0240"

FIGURE 20
MICROWAVE PROPERTIES OF FERRIMIC 1331,
WITH LENGTH AS PARAMETER

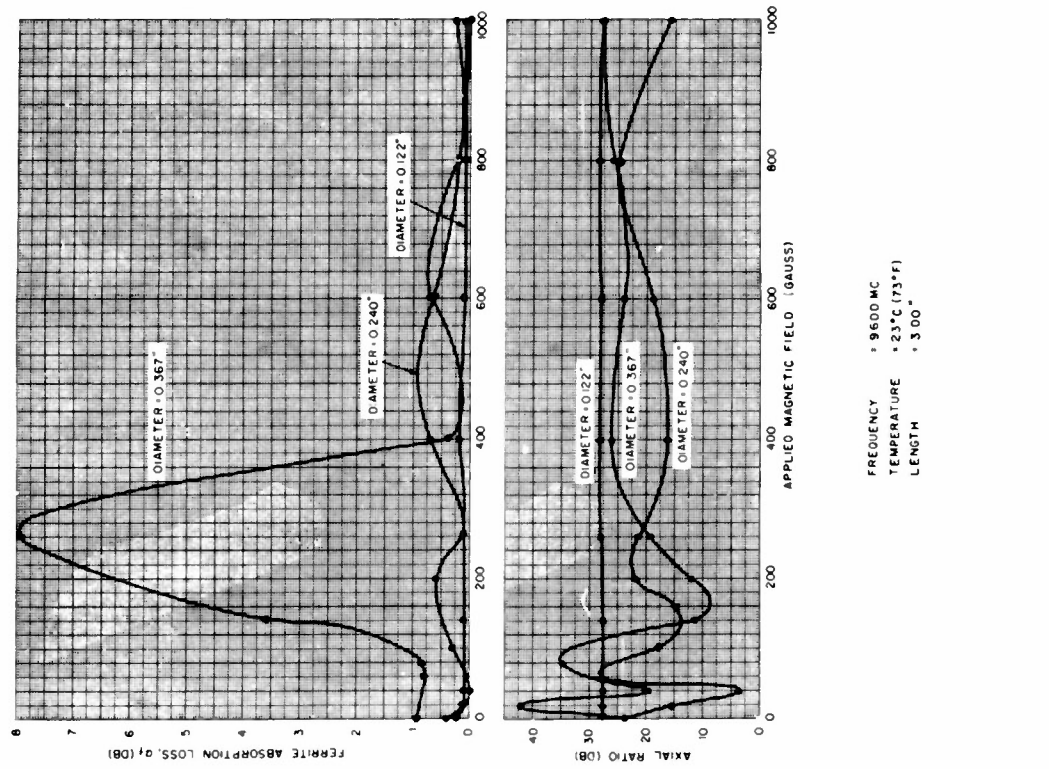
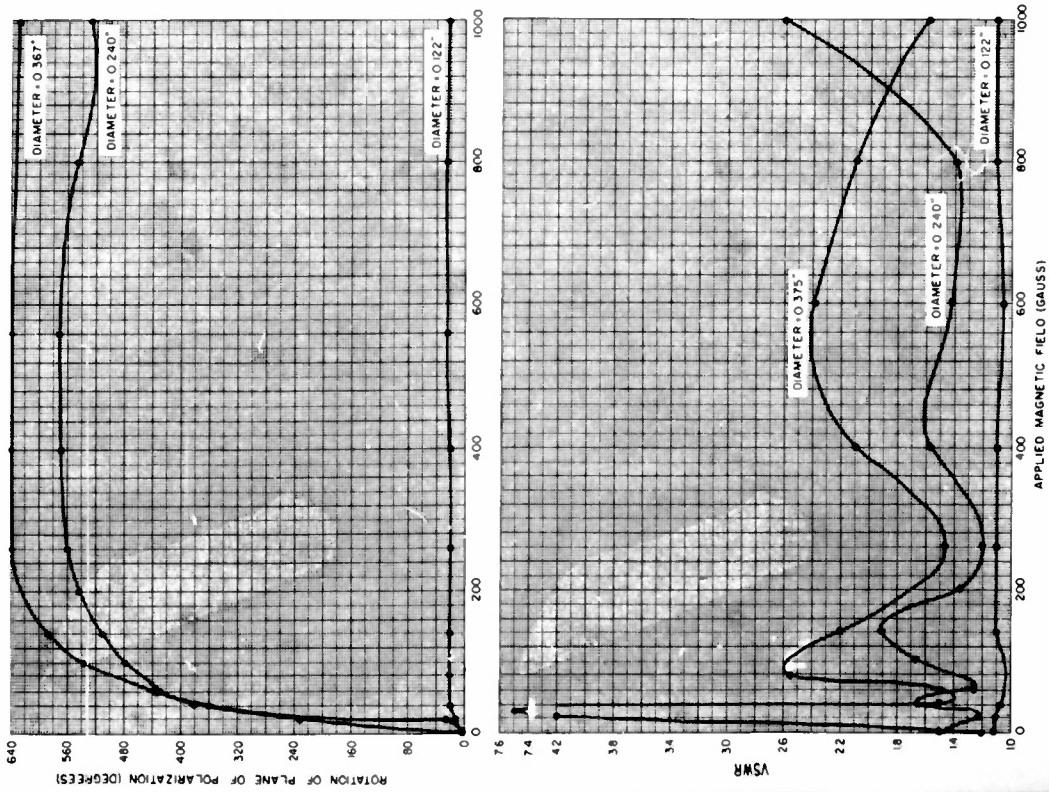

FREQUENCY : 9600 MC
TEMPERATURE : 23°C (73°F)
LENGTH : 3.00"

FIGURE 21
MICROWAVE PROPERTIES OF FERRIMIC 1331
WITH DIAMETER AS PARAMETER

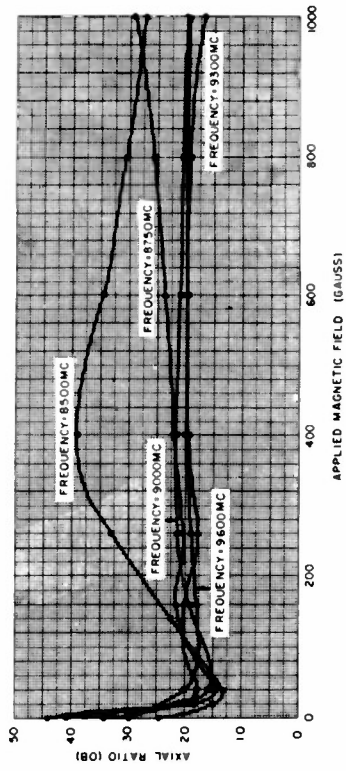
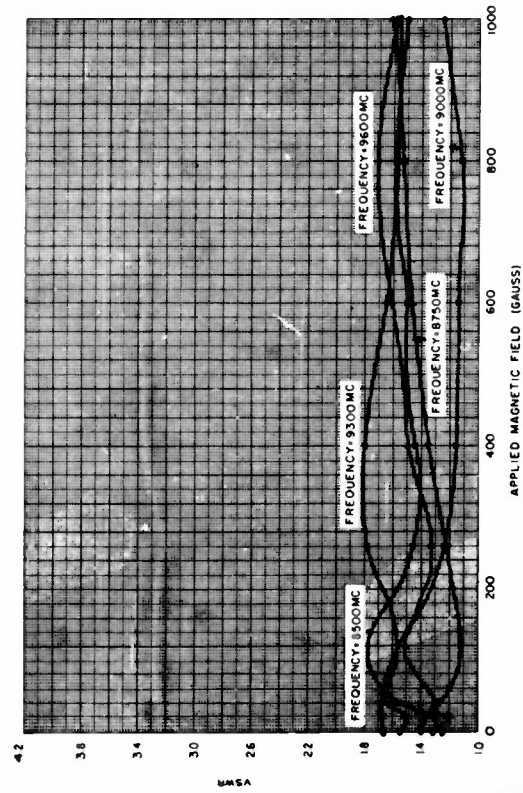
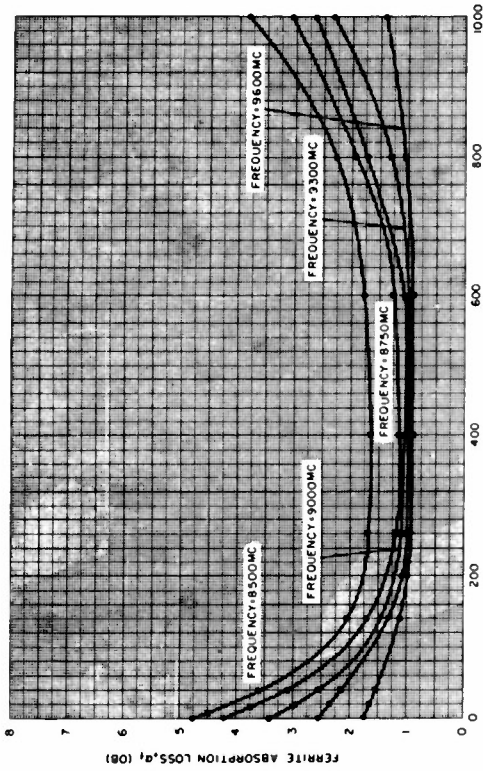
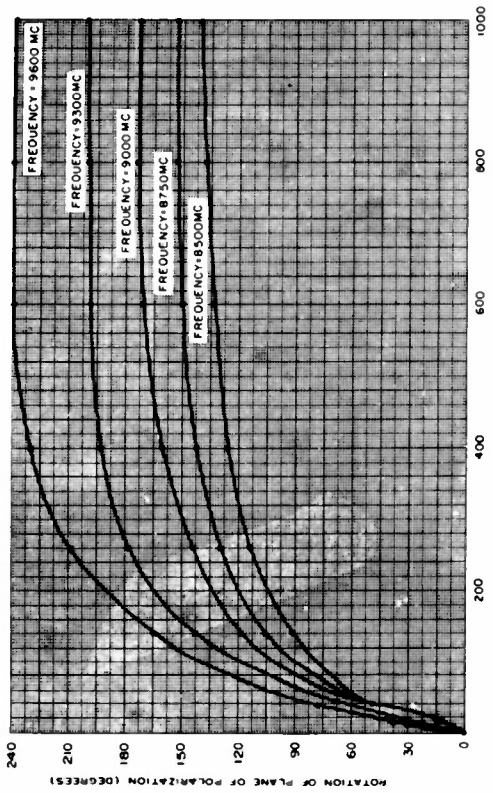

DIAMETER = 0.263"
 TEMPERATURE = 23°C (73°F)
 LENGTH = 3.00"

FIGURE 22
 MICROWAVE PROPERTIES OF FERRIMIC A-10
 WITH FREQUENCY AS PARAMETER

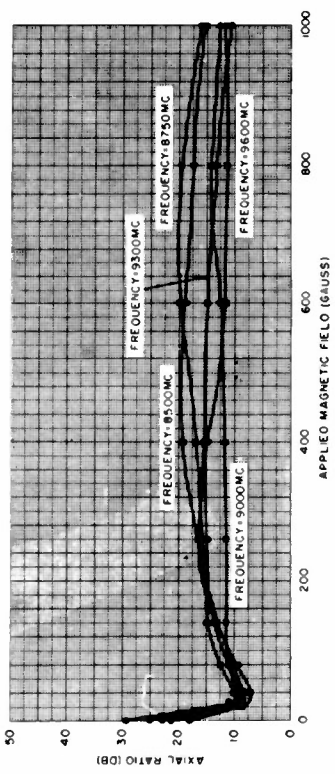
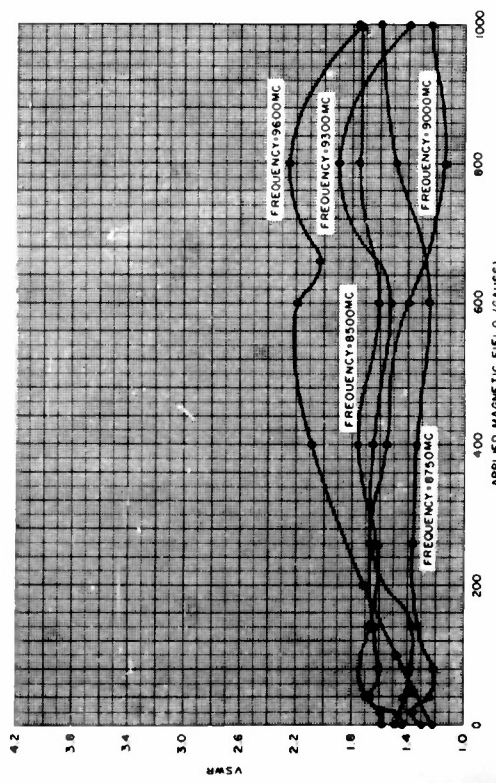
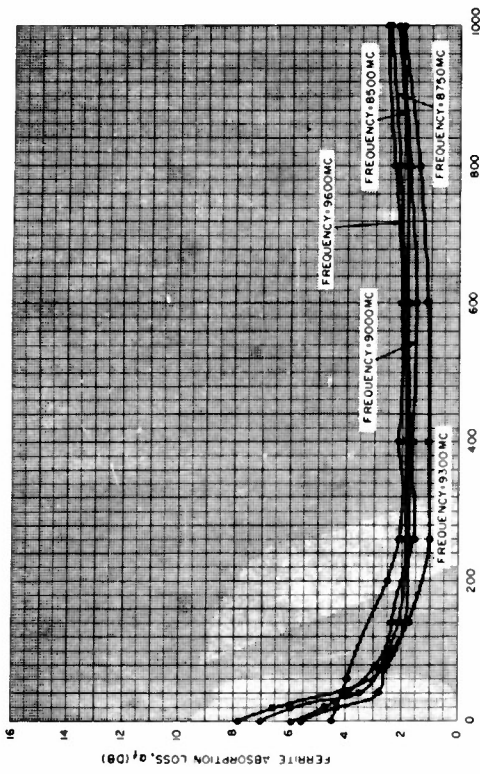
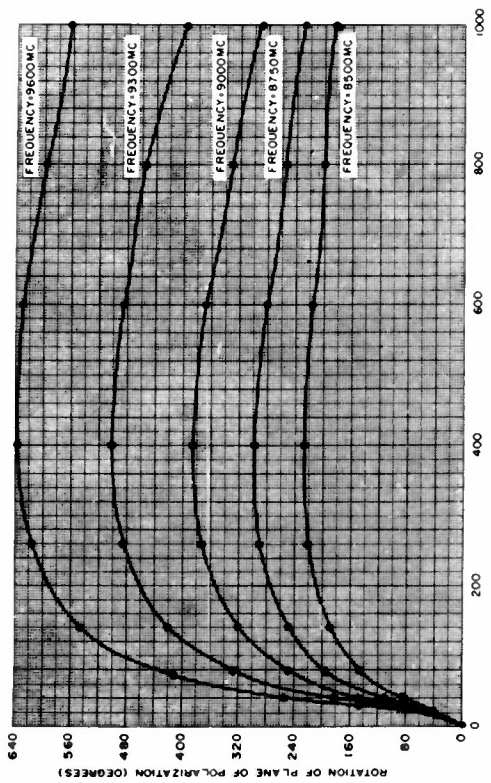

DIAMETER .0242"
TEMPERATURE 125°C(13°F)
LENGTH .500"

FIGURE 23
MICROWAVE PROPERTIES OF FERRIMIC D-21
WITH FREQUENCY AS PARAMETER

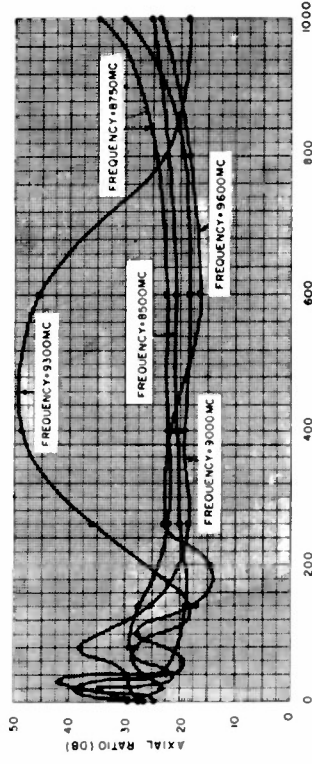
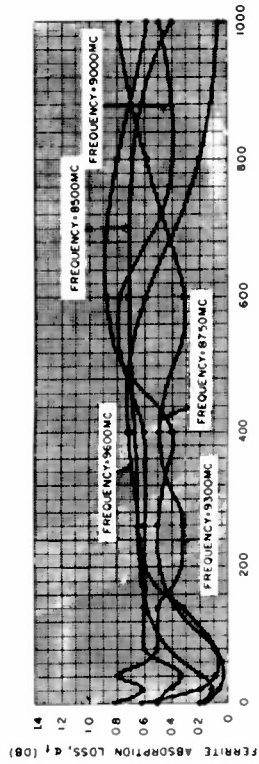
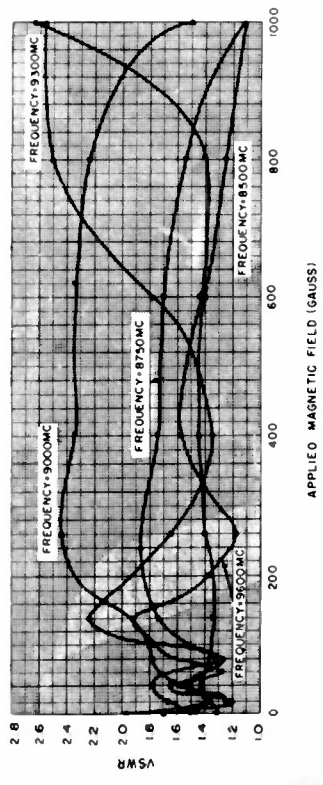
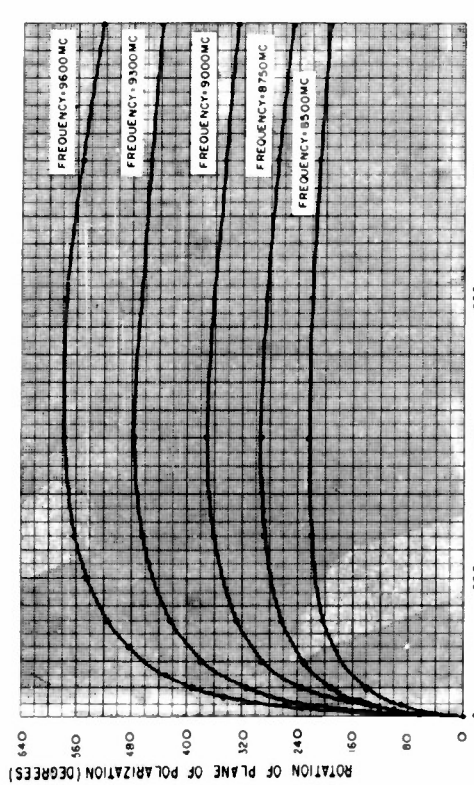

TEMPERATURE = 23°C (73°F)
 DIAMETER = 0.240"
 LENGTH = 3.00"

FIGURE 24
 MICROWAVE PROPERTIES OF FERRIMIC
 WITH FREQUENCY AS PARAMETER

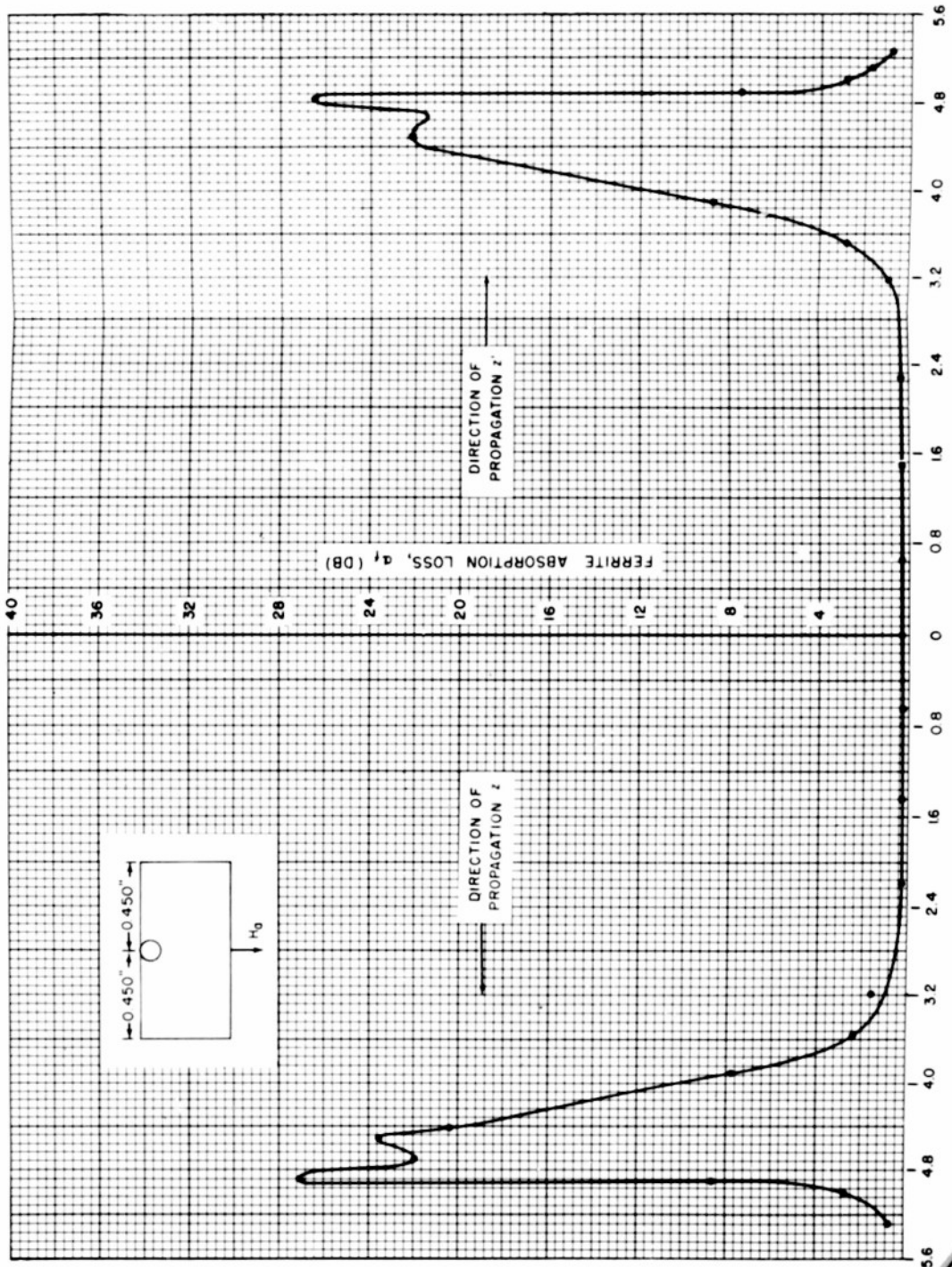

APPLIED MAGNETIC FIELD (KILOGAUSS)



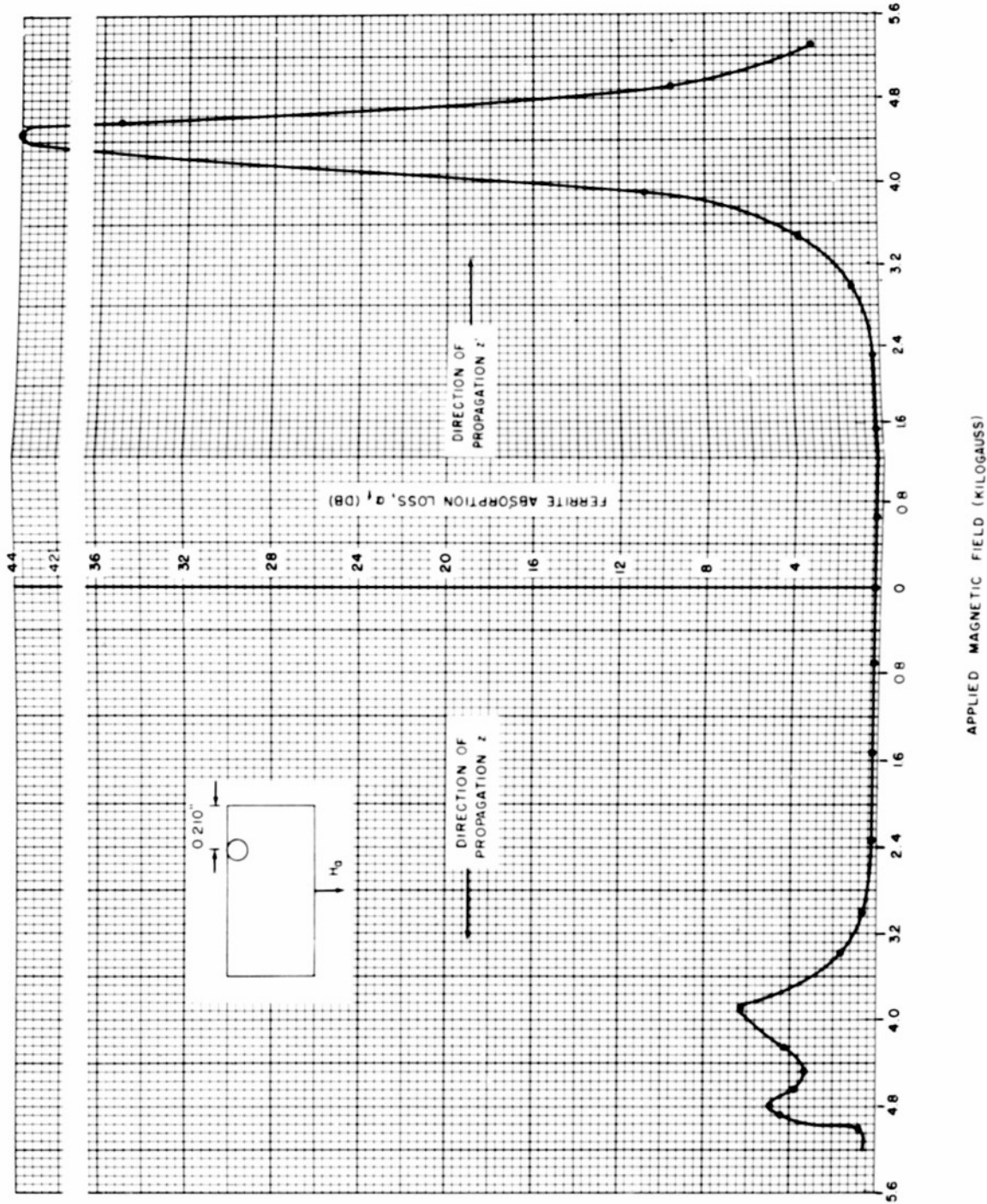

2

FIGURE 25
 MICROWAVE PROPERTY OF FERRAMIC 1331
 IN RECTANGULAR WAVEGUIDE, WITH
 LOCATION OF FERRITE AS PARAMETER

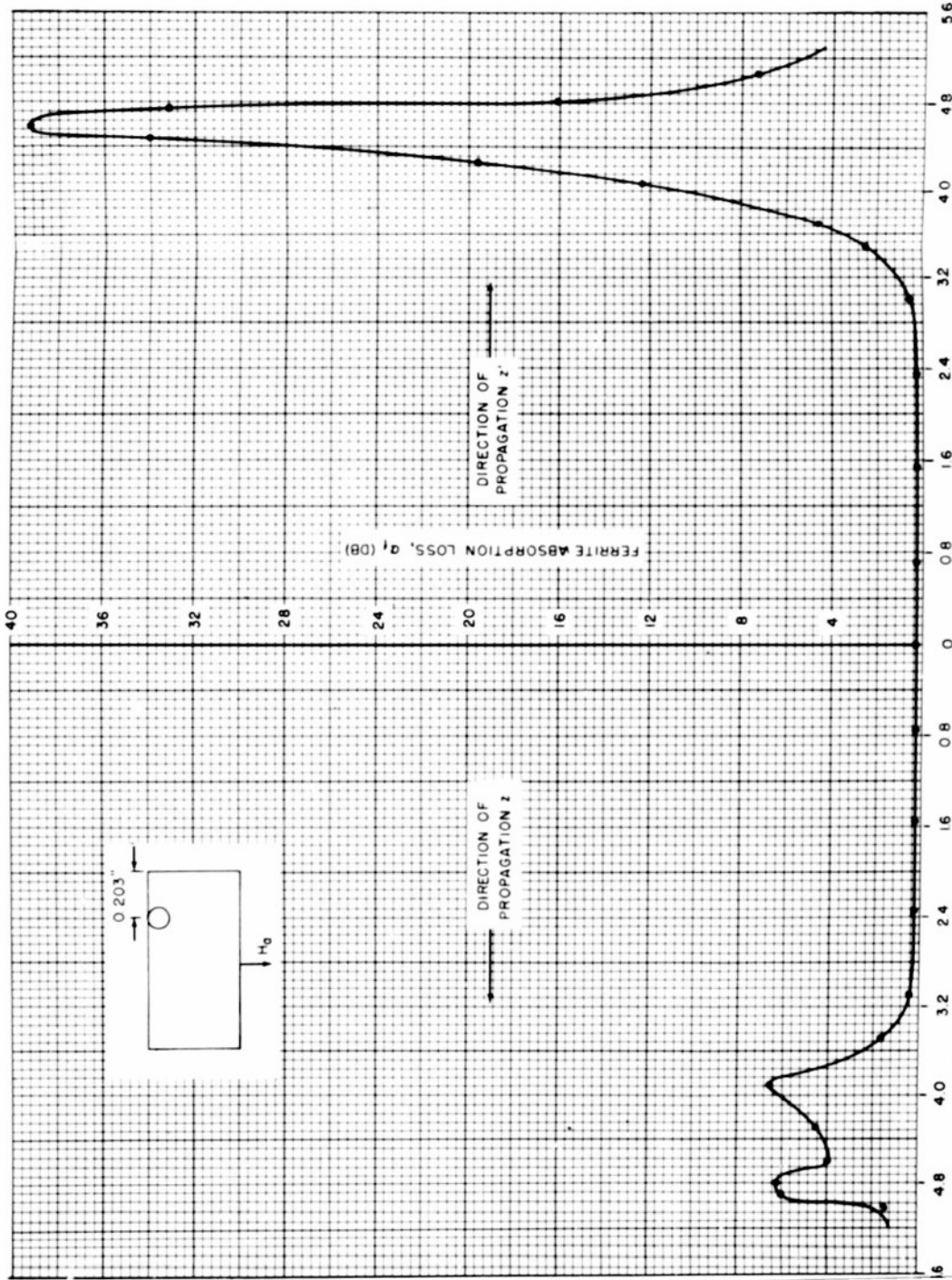

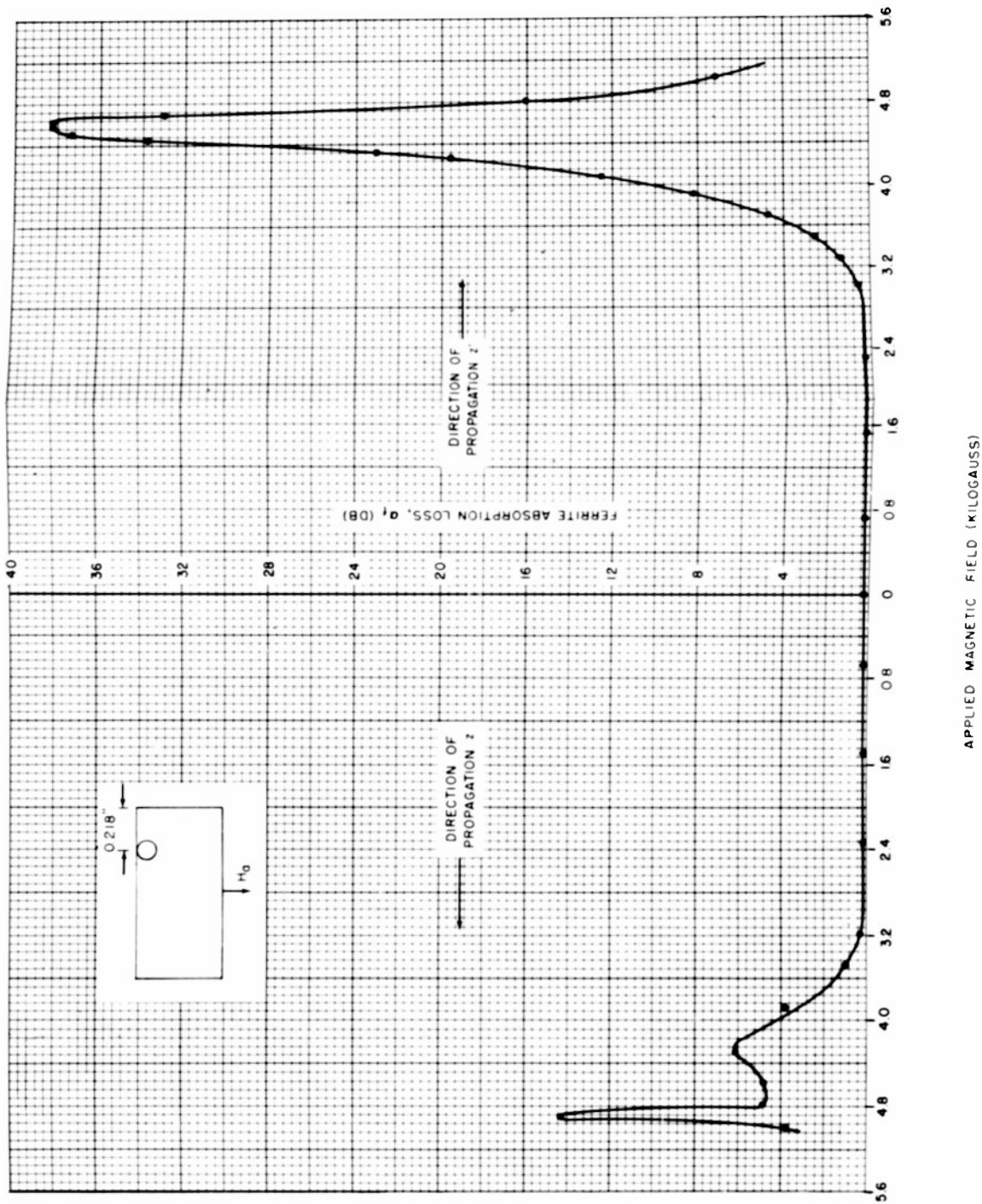

2

FIGURE 26
 DETERMINATION OF PLANES OF CIRCULAR
 POLARIZATION IN RECTANGULAR WAVEGUIDE
 USING FERRAMIC 1331

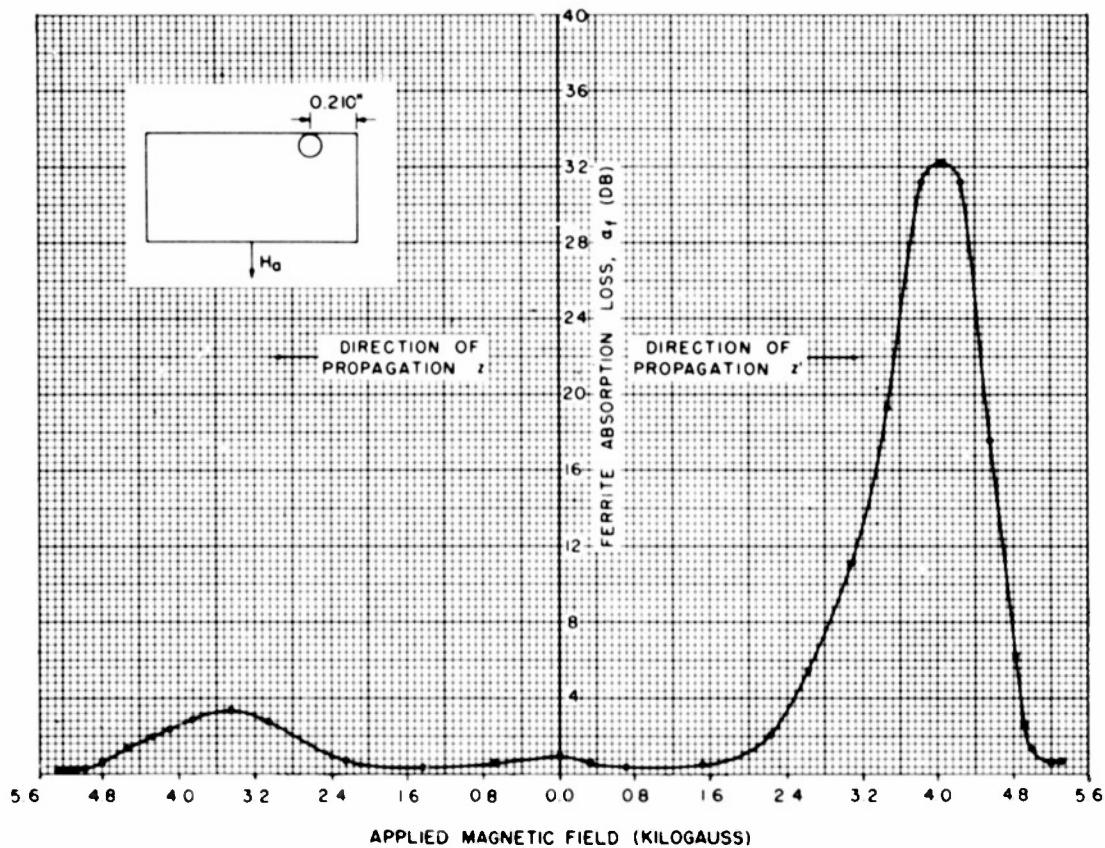

TEMPERATURE • 23°C (73°F)

FREQUENCY • 9000 MC

DIAMETER • 0.125"

LENGTH • 3.00"

FIGURE 27
MICROWAVE PROPERTY OF FERRAMIC A-106
IN RECTANGULAR WAVEGUIDE AT
PLANE OF CIRCULAR POLARIZATION

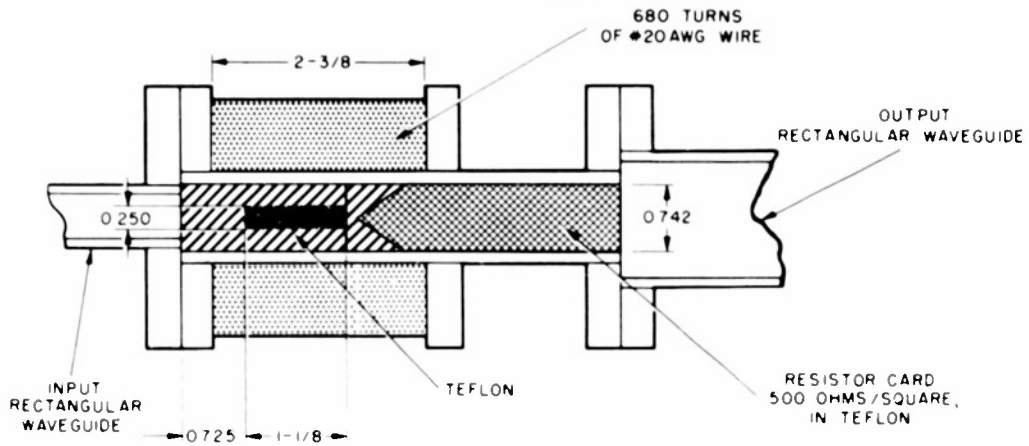

ATTENUATOR

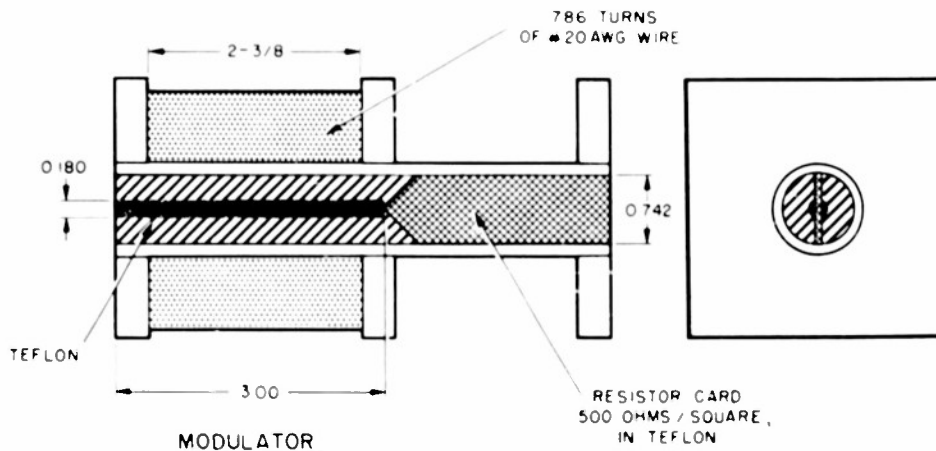

MODULATOR

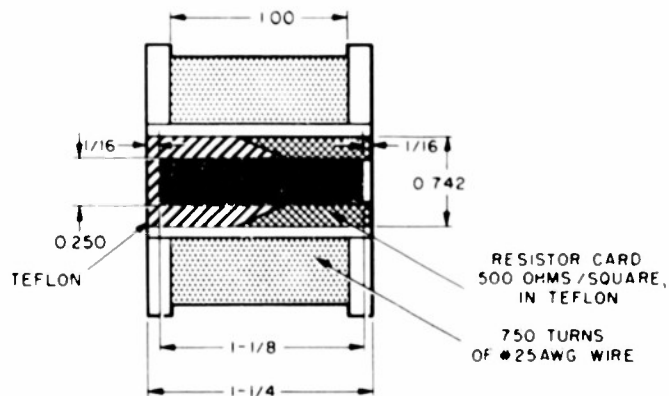

SWITCH

FIGURE 28
DIMENSIONS OF
TYPE I COMPONENTS

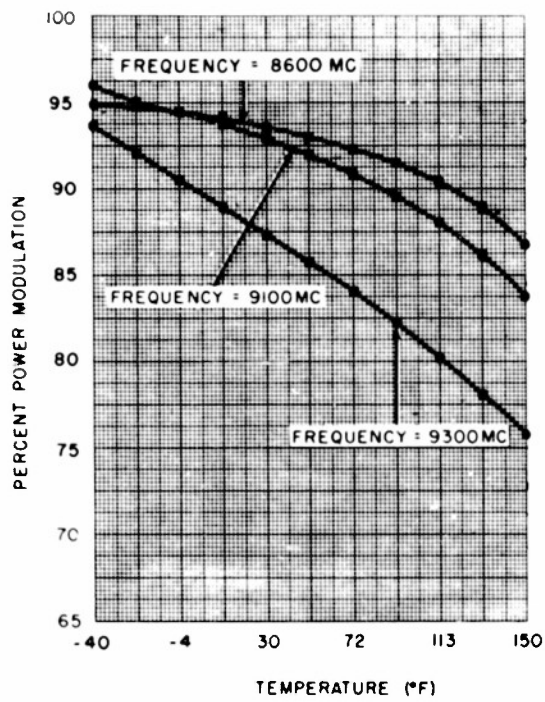

FIGURE 29
PERCENT POWER MODULATION VS TEMPERATURE
FOR TYPE I MODULATOR USING FERRAMIC 1331,
WITH FREQUENCY AS PARAMETER

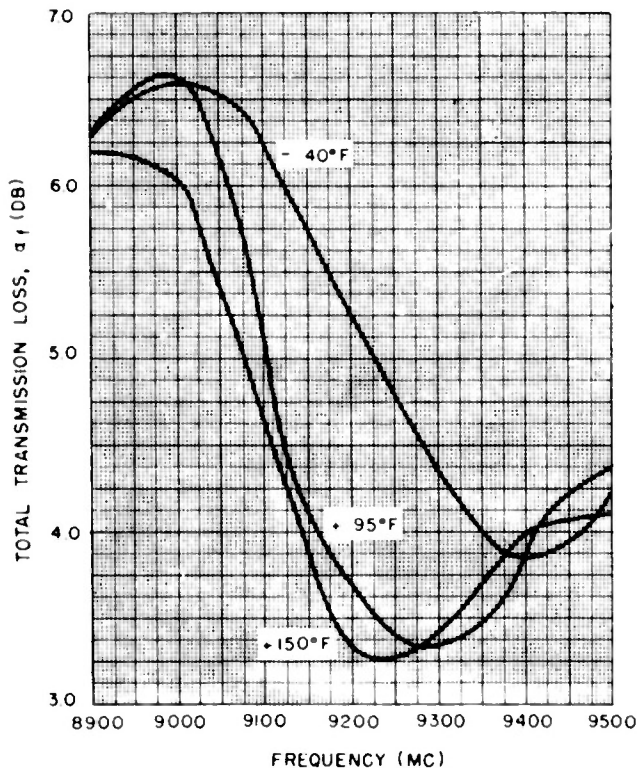

FIGURE 30
TOTAL TRANSMISSION LOSS VS FREQUENCY
FOR TYPE I MODULATOR USING FERRAMIC
1331, WITH TEMPERATURE AS PARAMETER

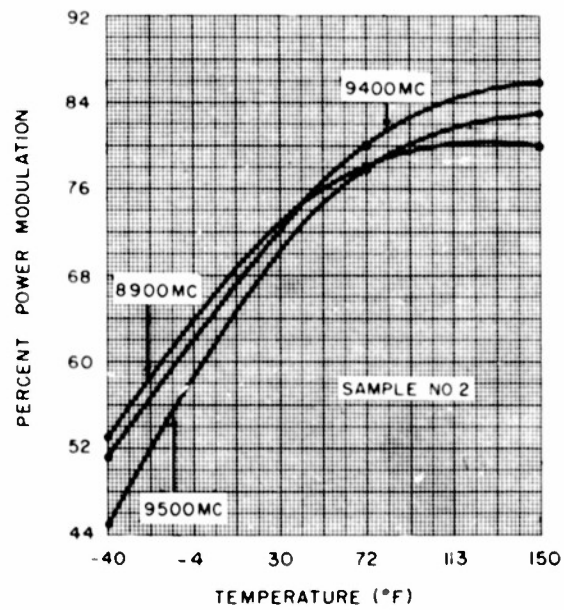
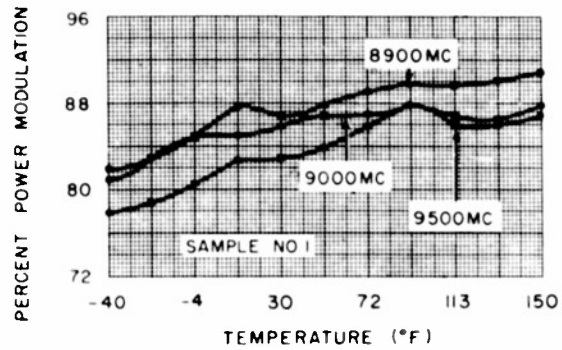

FIGURE 31
PERCENT POWER MODULATION VS TEMPERATURE
FOR TYPE I MODULATOR USING TWO SAMPLES
OF FERRAMIC A-106, WITH FREQUENCY
AS PARAMETER

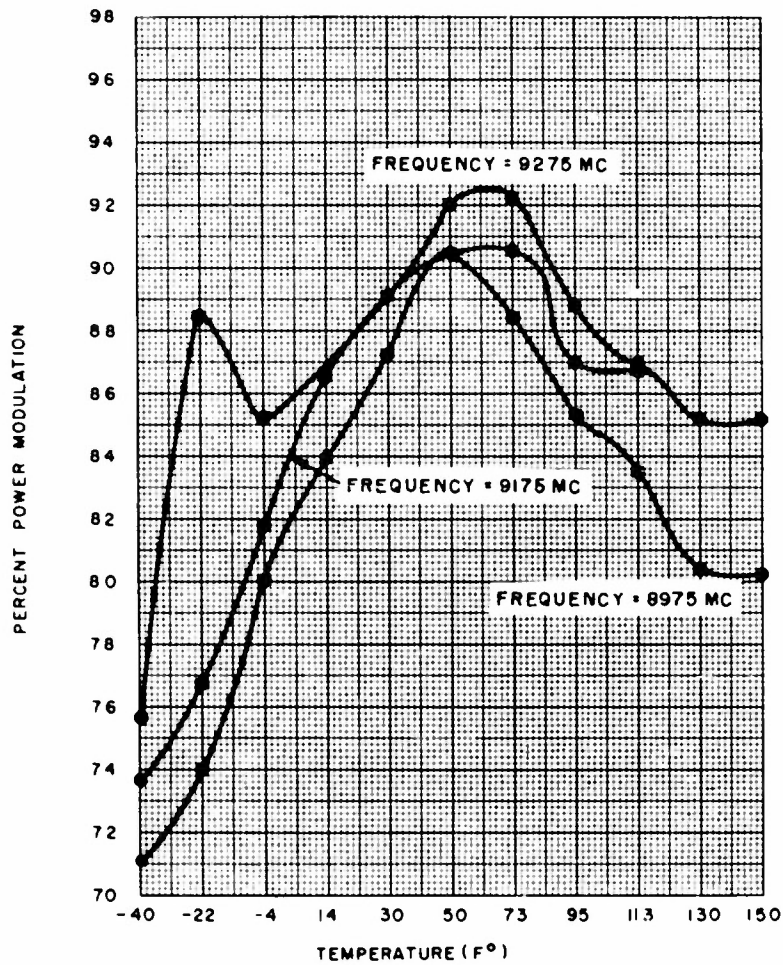

FIGURE 32
PERCENT POWER MODULATION VS TEMPERATURE
FOR TYPE I MODULATOR USING FERRAMIC D-216,
WITH FREQUENCY AS PARAMETER

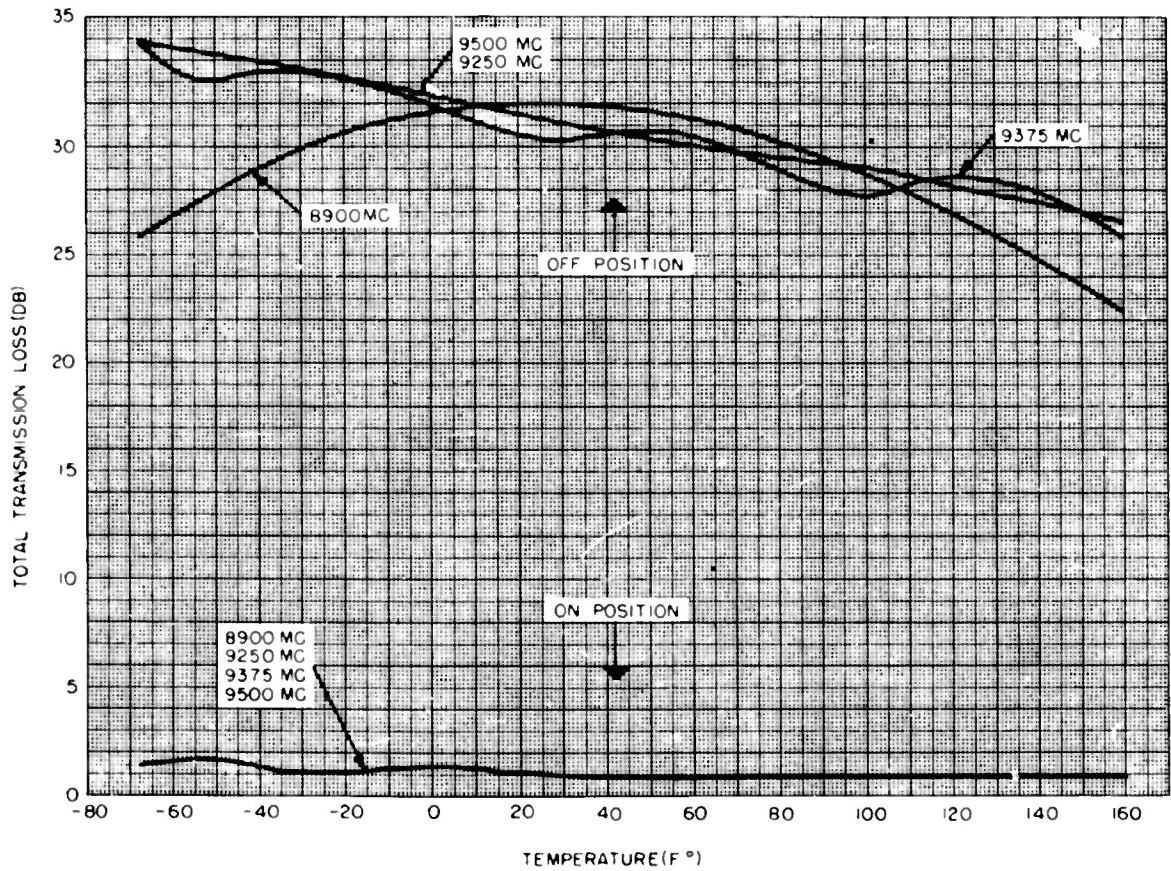
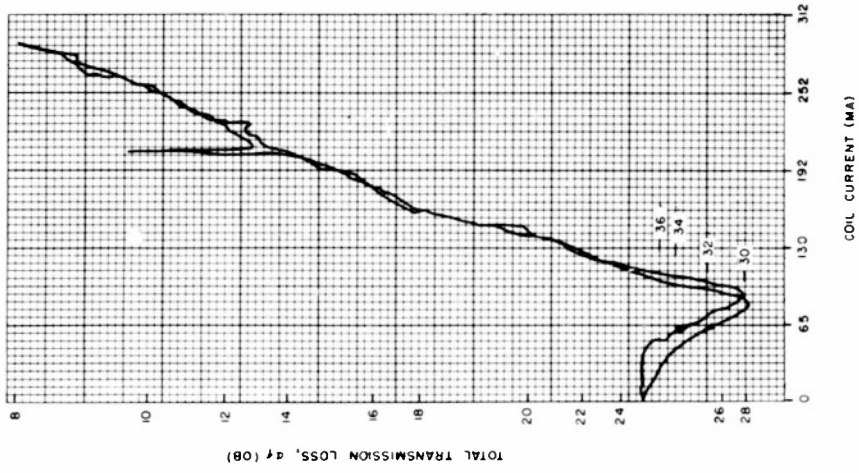
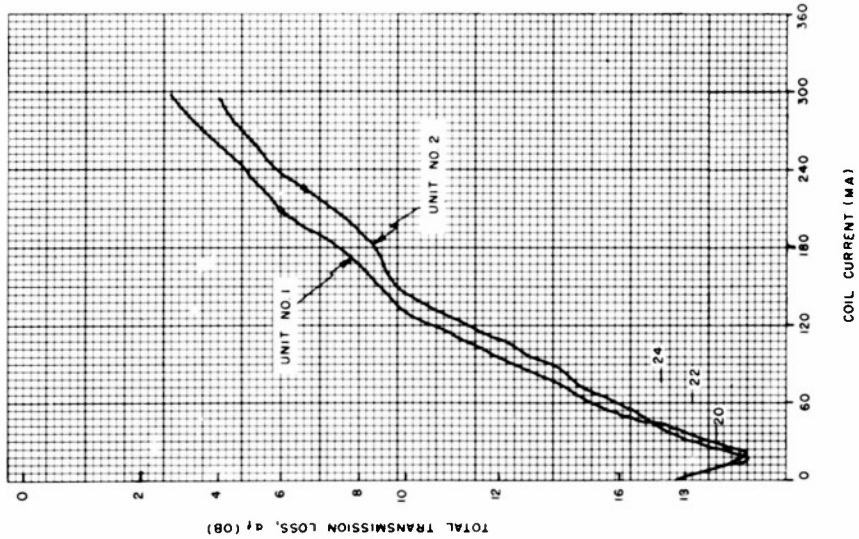

FIGURE 33
TOTAL TRANSMISSION LOSS VS TEMPERATURE
FOR TYPE I SWITCH USING FERRAMIC 1331,
WITH FREQUENCY AS PARAMETER



b
TWO UNITS
IN SERIES



a
SINGLE UNIT

FIGURE 34
TOTAL TRANSMISSION LOSS VS
COIL CURRENT FOR TYPE I
ATTENUATORS USING FERRAMIC 1331

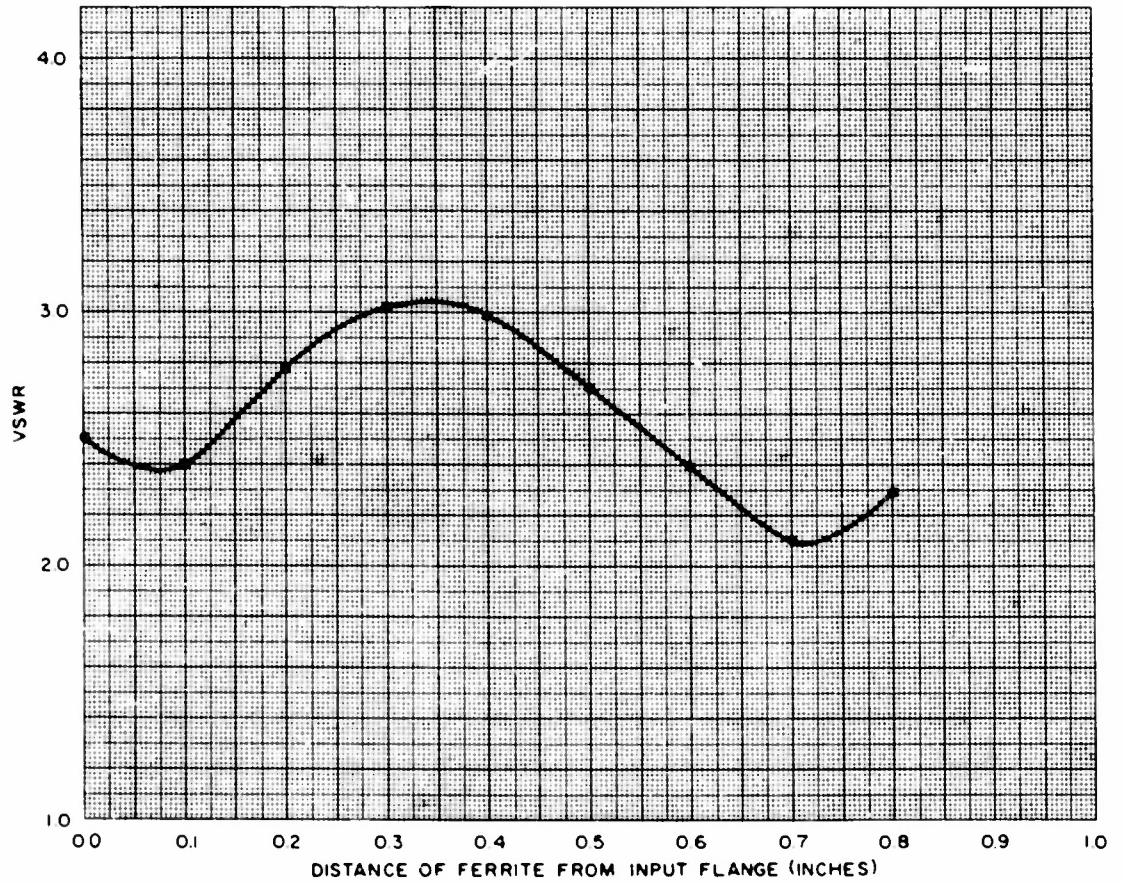

FIGURE 35
VSWR VS FERRITE POSITION FOR TYPE I
ATTENUATOR USING FERRAMIC 1331

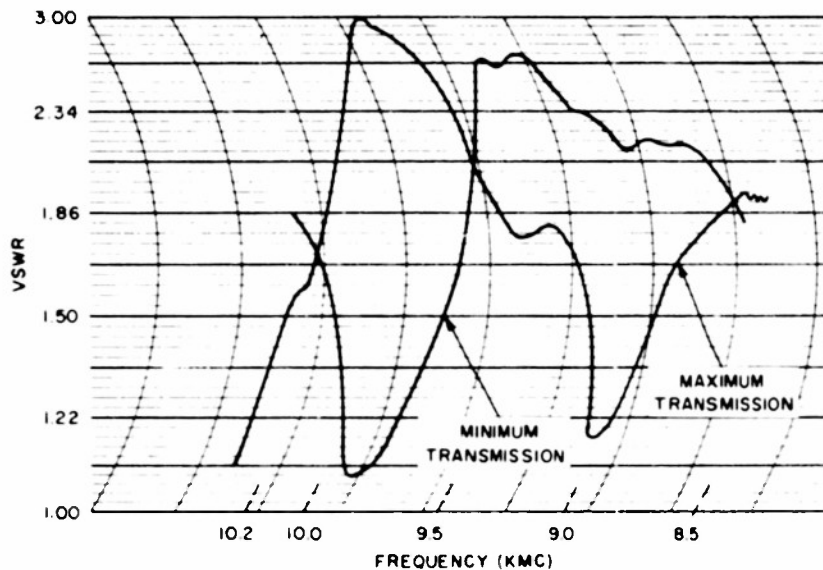

FIGURE 36
VSWR VS FREQUENCY FOR TYPE I ATTENUATOR
USING FERRAMIC 1331, AT POINTS OF MAXIMUM
AND MINIMUM TRANSMISSION

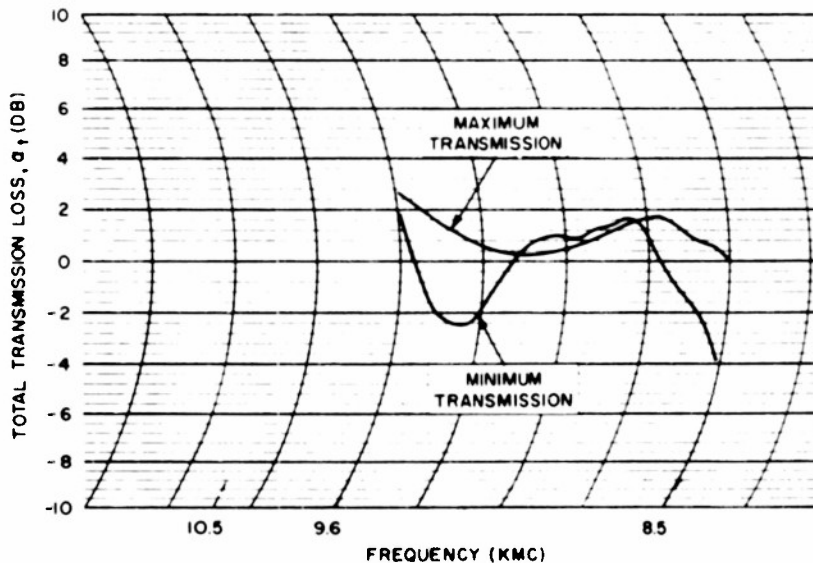
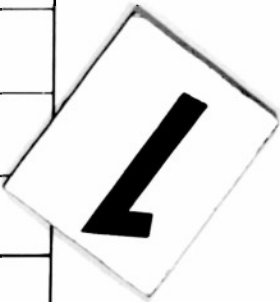

FIGURE 37
TOTAL TRANSMISSION LOSS VS FREQUENCY FOR TYPE I
ATTENUATOR USING FERRAMIC 1331, AT POINTS OF
MAXIMUM AND MINIMUM TRANSMISSION



PERIOD COVERED: 10/17/53 TO 1/17/54

	1953					1954												
	JULY	AUG	SEPT	OCT	NOV	DEC	JAN	FEB	MARCH	APRIL	MAY	JUNE	JULY	AUG	SEPT	OCT	NOV	
(1) SURVEY STUDY OF AVAILABLE LITERATURE																		
ASSEMBLY AND CALIBRATION OF MEASUREMENT EQUIPMENT SETUP																		
(2) EXPERIMENTAL INVESTIGATION STUDY OF FERRITE PROPERTIES IN CIRCULAR WAVEGUIDE																		
STUDY OF FERRITE PROPERTIES IN RECTANGULAR WAVEGUIDE																		
(3) DEVELOPMENT OF COMPONENTS STUDY AND DEVELOPMENT																		
CONSTRUCTION AND TEST OF UNITS TO BE DELIVERED																		
(4) PUBLICATIONS																		



Armed Services Technical Information Agency

Because of our limited supply, you are requested to return this copy **WHEN IT HAS SERVED YOUR PURPOSE** so that it may be made available to other requesters. Your cooperation will be appreciated.

AD

46044

NOTICE: WHEN GOVERNMENT OR OTHER DRAWINGS, SPECIFICATIONS OR OTHER DATA ARE USED FOR ANY PURPOSE OTHER THAN IN CONNECTION WITH A DEFINITELY RELATED GOVERNMENT PROCUREMENT OPERATION, THE U. S. GOVERNMENT THEREBY INCURS NO RESPONSIBILITY, NOR ANY OBLIGATION WHATSOEVER; AND THE FACT THAT THE GOVERNMENT MAY HAVE FORMULATED, FURNISHED, OR IN ANY WAY SUPPLIED THE SAID DRAWINGS, SPECIFICATIONS, OR OTHER DATA IS NOT TO BE REGARDED BY IMPLICATION OR OTHERWISE AS IN ANY MANNER LICENSING THE HOLDER OR ANY OTHER PERSON OR CORPORATION, OR CONVEYING ANY RIGHTS OR PERMISSION TO MANUFACTURE, USE OR SELL ANY PATENTED INVENTION THAT MAY IN ANY WAY BE RELATED THERETO.

Reproduced by
DOCUMENT SERVICE CENTER
KNOTT BUILDING, DAYTON, 2, OHIO

UNCLASSIFIED