

UNCLASSIFIED

AD NUMBER

AD056138

LIMITATION CHANGES

TO:

Approved for public release; distribution is unlimited.

FROM:

Distribution authorized to U.S. Gov't. agencies and their contractors;
Administrative/Operational Use; MAR 1965. Other requests shall be referred to National Aeronautics and Space Administration, Code AO, 300 "E" Street, SW, Washington, DC 20546-0001.

AUTHORITY

NASA TR server website

THIS PAGE IS UNCLASSIFIED

UNCLASSIFIED

AD NUMBER

AD056138

CLASSIFICATION CHANGES

TO:

UNCLASSIFIED

FROM:

CONFIDENTIAL

AUTHORITY

1 May 1959, per ASTIA TAB No. U59-9, per document marking

THIS PAGE IS UNCLASSIFIED

UNCLASSIFIED

A D

56138

Armed Services Technical Information Agency

ARLINGTON HALL STATION
ARLINGTON 12 VIRGINIA

CLASSIFICATION CHANGED FROM
CONFIDENTIAL TO UNCLASSIFIED
PER AUTHORITY LISTED IN ASTIA
TAB NO. U59-9 1 MAY 59

NOTICE: WHEN GOVERNMENT OR OTHER DRAWINGS, SPECIFICATIONS OR OTHER DATA ARE USED FOR ANY PURPOSE OTHER THAN IN CONNECTION WITH A DEFINITELY RELATED GOVERNMENT PROCUREMENT OPERATION, THE U. S. GOVERNMENT THEREBY INCURS NO RESPONSIBILITY, NOR ANY OBLIGATION WHATSOEVER; AND THE FACT THAT THE GOVERNMENT MAY HAVE FORMULATED, FURNISHED, OR IN ANY WAY SUPPLIED THE SAID DRAWINGS, SPECIFICATIONS, OR OTHER DATA IS NOT TO BE REGARDED BY IMPLICATION OR OTHERWISE AS IN ANY MANNER LICENSING THE HOLDER OR ANY OTHER PERSON OR CORPORATION, OR CONVEYING ANY RIGHTS OR PERMISSION TO MANUFACTURE, USE OR SELL ANY PATENTED INVENTION THAT MAY IN ANY WAY BE RELATED THERETO.

UNCLASSIFIED

CONFIDENTIAL

Copy 74
RM L54L02

NACA RM L54L02

AD NO. 56138

ASTIA FILE COPY



SEARCH MEMORANDUM

MODEL INVESTIGATION OF THE EFFECT OF MOUNTING

HYDRO-SKIS ON SHOCK ABSORBERS

By Edward L. Hoffman and Lloyd J. Fisher

Langley Aeronautical Laboratory
Langley Field, Va.

CLASSIFIED DOCUMENT

This material contains information affecting the National Defense of the United States within the meaning of the espionage laws, Title 18, U.S.C., Secs. 793 and 794, the transmission or revelation of which in any manner to an unauthorized person is prohibited by law.

NATIONAL ADVISORY COMMITTEE FOR AERONAUTICS

WASHINGTON

March 1, 1955

CONFIDENTIAL

55A A

9890

MAR 17 1955

NATIONAL ADVISORY COMMITTEE FOR AERONAUTICS

RESEARCH MEMORANDUM

MODEL INVESTIGATION OF THE EFFECT OF MOUNTING

HYDRO-SKIS ON SHOCK ABSORBERS

By Edward L. Hoffman and Lloyd J. Fisher

SUMMARY

A rough-water landing investigation of a model of a hydro-ski seaplane design was conducted in Langley tank no. 2 to determine the effect on the landing motions and vertical accelerations of mounting the hydro-ski on shock-absorber struts. The tests were made at one landing trim and wave height over a range of wave length for three hydro-ski configurations (fixed, translating, and pivoting). In addition, the effect of stabilizing the model in trim was investigated.

By mounting the hydro-ski on a shock-absorber strut, the rough-water vertical landing accelerations and rise of the test model were significantly reduced. In general, for the particular hydro-ski configurations tested, the translating-ski arrangement gave slightly lower maximum vertical accelerations than the pivoting-ski arrangement. The shock-absorber struts reduced the vertical landing accelerations most at the shorter wave lengths tested. Only minor improvements in rough-water landing characteristics of the model were realized by the trim stabilization used in these tests, but fixed-trim landings indicated that considerable improvements were available if the amount of trim control could be made great enough.

INTRODUCTION

Hydro-skis are a means of reducing the rough-water landing impacts of water-based airplanes. The present investigation concerns the mounting of hydro-skis on shock-absorber struts as a method for further reduction of hydrodynamic landing impacts. The investigation was made to compare the landing impacts of a seaplane model having a hydro-ski mounted on shock-absorber struts with those of the same model having the hydro-ski mounted on rigid struts.

A rough-water landing investigation was conducted by using an existing model of a Navy seaplane design (Langley tank model 280) as a test

CONFIDENTIAL

55A A

9890

vehicle. The model was equipped with a hydro-ski that could be mounted on rigid struts, on a shock-absorber strut so that the ski moved normal to its keel without changing trim (translated), or on a shock-absorber strut so that the ski changed trim when a load was applied (pivoted near bow).

Landings were made at a trim of 90° and at a landing speed of 53 feet per second (155 knots, full scale) in waves 3 inches high (6 feet, full scale). The wave length-height ratios were varied from 30 to 70. Most of the landings were made with the trimming of the model damped aerodynamically by an artificial stabilization device that incorporated a rate-sensitive gyroscope to control the elevators. In addition, landings were made with the usual fixed-elevator configuration and with the model fixed in trim.

SYMBOLS

b_s	beam of hydro-ski, ft
C_{Δ_0}	gross load coefficient of hydro-ski, Δ_0/wb_s^3
\bar{c}	wing mean aerodynamic chord, ft
g	acceleration due to gravity, 32.2 ft/sec ²
H_w	wave height, in.
L_w	wave length, in.
q	trimming angular velocity of model, deg/sec
V_h	horizontal hull velocity, fps
V_v	vertical hull velocity, fps
w	specific weight of water, 63.2 lb/cu ft used for these tests
Δ_0	initial load on water, gross weight, lb
δ_e	elevator deflection, deg
τ	trim, angle between hull reference line and smooth water surface, deg

CONFIDENTIAL

APPARATUS

This investigation was conducted in the Langley tank no. 2 with the main towing carriage. An existing 1/24-scale model of a Bureau of Aeronautics, Department of the Navy, 160,000-pound seaplane design (fig. 1) that had previously been tested (ref. 1) was used as a test vehicle. Pertinent dimensions of the tank model (designated Langley tank model 280) and an equivalent full-scale seaplane are listed in table I. A photograph of the dynamic model attached to the Langley tank no. 2 fore-and-aft gear is shown as figure 2. The wing tip floats were removed to meet gross-weight requirements for these tests. For landing tests with this gear, the model had approximately 3 feet of fore-and-aft freedom with respect to the towing carriage in order to absorb longitudinal accelerations introduced by impacts and to permit the model to act as a free body in the longitudinal direction. The model was free to trim about a pivot located at the center of gravity and was free to move vertically but was restrained laterally and in roll and yaw. The vertically moving weight of the model and gear was 11.57 pounds which corresponds to a full-scale gross weight of 162,000 pounds. The longitudinally moving weight was approximately 65 percent higher than the design gross weight because of the additional moving weight of the fore-and-aft gear.

An 18-channel recording oscillograph located in the towing carriage was used to record data. A strain-gage type of accelerometer mounted on the towing staff of the model was used to measure vertical accelerations (static condition considered zero). The natural frequencies of the accelerometer and recording galvanometer were 165 cps and 150 cps, respectively. Both were damped to about 65 percent of critical damping. Slide-wire pickups were used to measure trim, rise of the center of gravity, and fore-and-aft position of the model and to measure deflection of the shock strut. An electrically actuated trim lock which was attached to the towing staff fixed the trim of the model in the air during the landing approach. The trim lock was automatically released when an electrical contact at the sternpost of the model or at the trailing edge of the hydro-ski touched the water. When fixed-trim landings were desired, the actuating mechanism was disconnected so that the trim lock was not released.

The artificial stabilization device used to provide damping in trim consisted of a pneumatic elevator servoactuator and a rate gyroscope. A photograph of the control system is shown as figure 3. Air was supplied to the gyroscopic rotor to produce a given speed and to the servoactuator to provide the force required to move the elevators. Air was also supplied to the gyro pickoff valve which varied the signal pressure to the servoactuator. The gearing ratio of elevator deflection to trimming velocity δ_e/q used for these tests was approximately 4. Additional information on this type control system may be found in reference 2. For fixed-elevator landings the air supply was stopped and the elevators were locked at the desired positions.

A drawing of the hydro-ski is shown in figure 4 and pertinent dimensions of the ski are listed in table I. Figure 5 shows the shock-absorber-strut—hydro-ski configurations investigated and indicates the limits of motion of the hydro-ski. For the translating-ski configuration (fig. 5(a)), the ski had an angle of incidence of 0° with respect to the hull reference line and 1-inch (model-scale) normal travel. The pivoting-ski configuration (fig. 5(b)) was pivoted near the bow of the ski and the ski had an initial angle of incidence of 4° . Full compression of the shock-absorber strut allowed the ski to change its angle of incidence to -4° . Since the strut fastenings to the model fuselage were rigid, it was necessary to allow the bow pivot a small amount of fore-and-aft motion. The fixed-ski configuration was obtained by locking the pivoting ski at an angle of incidence of 0° .

A drawing of the shock-absorber strut used for both the translating and pivoting skis is shown in figure 6. The linear-motion ball bushings were used to reduce strut friction and were especially necessary to reduce binding in the translating-ski configuration. Distilled water was used in the strut instead of shock-absorber fluid in order to approximate more closely the scale Reynolds number of the flow through the orifice. Pertinent dimensions of the model strut and a comparable full-scale strut are listed in table I; the shock-absorber characteristics that were obtained from bench tests are presented in figure 7. Figure 7(a) is a plot of spring force against stroke; figure 7(b) is a plot of the stroke obtained from test drops of various heights; and figure 7(c) is a plot of hydraulic force against telescoping velocity that was obtained from the drop tests. The weight used for the drop tests was equal to the gross model weight. For telescoping velocities above 1.5 feet per second, turbulent damping was obtained (comparable to full scale).

The Langley tank no. 2 wave maker was used to produce the rough-water conditions. The wave generator consisted of an oscillating plate hinged at the bottom of the tank. The frequency and stroke of the plate oscillations were changed to vary the wave conditions.

PROCEDURE

The rough-water landing investigation was made perpendicular to oncoming waves. The model was locked at the desired landing trim of 90° , and the desired elevator condition was introduced either by locking the elevators or by supplying air to the elevator servoactuator and the rate gyroscope. The towing carriage was brought up to a speed sufficient to make the model fly and was then decelerated at a constant rate. As the carriage decelerated, the model glided to a landing at a speed of 53 feet per second (155 knots, full scale). The carriage deceleration was selected to keep the model between the fore-and-aft limits of travel during the landing.

CONFIDENTIAL

Landings were made in waves 3 inches high (6 feet, full scale) with length-height ratios varying from 30 to 70. Previous experience with the model (ref. 1) showed that the time-history records of vertical acceleration of the model impact with a wave generally had two peaks. The first peak was caused by the hydro-ski contacting the wave. As the ski continued through the wave, the model trimmed up and the afterbody of the hull contacted the wave so that a second peak acceleration was formed that sometimes was higher than the acceleration caused by the ski impact.

Trim control appeared to be a means of reducing the number of maximum accelerations caused by hull impacts and, since the object of the current investigation was to evaluate hydro-ski impacts, most of the landings were made with the model damped in trim. Fixed-trim and fixed-elevator landings were made in waves having a length-height ratio of 40 so that a comparison could be made of the effect of introducing damping in trim.

RESULTS AND DISCUSSION

The landing results obtained with the model artificially stabilized in trim are presented in figure 8 as plots of maximum vertical accelerations, maximum trim, and maximum rise against wave length-height ratio, and the envelope of these values is shown. The vertical accelerations plotted are the maximum values obtained from a landing run, regardless of whether they were caused by a hull impact or a ski impact. From the plots of maximum vertical accelerations presented in figure 8, the advantages of using shock-absorber struts are particularly noticeable at a wave length-height ratio of 30, where both shock-absorber configurations reduced the maximum acceleration about 60 percent as compared with the fixed-ski configuration. At a wave length-height ratio of 45 where the highest accelerations were indicated for the shock-absorber configurations, reductions of 33 percent for the translating ski and 29 percent for the pivoting ski were obtained. An examination of the maximum trim and rise envelopes of figure 8 shows that both shock absorbers gave a general reduction in maximum rise throughout the wave length-height ratios investigated; whereas, reductions in maximum trim are more apparent in the longer waves.

Although the purpose of artificially stabilizing the model in trim was to reduce the number of maximum landing accelerations caused by hull impacts, examination of accelerometer and motion-picture records indicated that hull impacts were not completely eliminated. Inasmuch as figure 8 contains both hull and ski impacts, figure 9 is presented with hydro-ski impacts only. Comparison of figures 8 and 9 for the fixed and pivoting skis shows that the maximum accelerations are generally caused by ski impacts, because most of the acceleration values are the same in both

CONFIDENTIAL

figures and the envelope of maximum accelerations remained the same. With the translating ski, however, a large number of maximum accelerations were caused by hull impacts, as shown by comparing figures 8(b) and 9(b). The large number of maximum accelerations caused by hull impacts for this configuration can be attributed to the proximity of the ski to the hull when the shock-absorber strut was compressed. A comparison of the maximum accelerations for hydro-ski impacts for the fixed- and translating-ski configurations (figs. 9(a) and 9(b)) shows the same reduction as figure 8 at a wave length-height ratio of 30 (approximately 60 percent). At a wave length-height ratio of 45, however, the maximum ski accelerations (fig. 9) are reduced 50 percent, as compared with 33 percent when both the hull and ski accelerations are considered (fig. 8). In figure 9(b) there is a tendency for the maximum-acceleration envelope to hold a fairly constant value over the wide range of wave length tested.

The results of damping in trim on the rough-water landing behavior are presented in figure 10 as plots of maximum acceleration, maximum trim, and maximum rise. The amount of damping in trim that was used in these tests had little effect on maximum accelerations and maximum trim but did cause a noticeable decrease in maximum rise. An indication of the extensive improvements in rough-water landing characteristics that could be realized by extreme increases in trim control can be seen from the fixed-trim results in figure 10.

In the foregoing comparisons of vertical accelerations to show the effect of shock-absorber struts, the maximum values obtained from landing runs have been considered. As a further comparison, time histories of vertical acceleration of individual impacts with similar initial-landing conditions are presented in figure 11 for wave length-height ratios of 40 and 70. The data presented are initial-landing impacts that occurred at the oncoming flank of a wave and are not necessarily the maximum accelerations obtained during the landings. The reductions in vertical accelerations that are realized by using shock-absorber struts are greater at the shorter wave length as was the case in figures 8 and 9. From the time-history records, it can be seen that the shock-absorber struts delay the time of maximum acceleration in addition to reducing the peak values.

CONCLUSIONS

The results of the rough-water landing investigation of a seaplane model equipped with a hydro-ski mounted rigidly and with shock-absorber struts lead to the following conclusions:

1. By mounting the hydro-ski on a shock-absorber strut, the rough-water vertical landing accelerations and rise of the test model were significantly reduced.

2. In general, for the particular hydro-ski configurations tested, the translating-ski arrangement gave slightly lower maximum vertical accelerations than the pivoting-ski arrangement.

3. The shock-absorber struts reduced the vertical landing accelerations most at the shortest wave length tested.

4. Only minor improvements in rough-water landing characteristics of the model were realized by the trim stabilization used in these tests, but fixed-trim landings indicated that considerable improvements were available if the amount of trim control could be made great enough.

Langley Aeronautical Laboratory,
National Advisory Committee for Aeronautics,
Langley Field, Va., November 19, 1954.

REFERENCES

1. Fisher, Lloyd J., and Hoffman, Edward L.: A Brief Hydrodynamic Investigation of a Navy Seaplane Design Equipped With a Hydro-Ski. NACA RM L53F04, 1953.
2. Schade, Robert O., and Hassell, James L., Jr.: The Effects on Dynamic Lateral Stability and Control of Large Artificial Variations in the Rotary Stability Derivatives. NACA Rep. 1151, 1953. (Supersedes NACA TN 2781.)

TABLE I.- PERTINENT DIMENSIONS OF LANGLEY TANK MODEL 280 AND
EQUIVALENT FULL-SCALE SEAPLANE DESIGN

	Full scale	Model
General:		
Design gross weight, lb	162,000	11.57
Pitching moment of inertia, slug-ft ²	1,400,000	0.18
Overall length, ft	103	4.29
Overall height, ft	36.25	1.51
Center-of-gravity location:		
Mean aerodynamic chord, percent	26	26
Height above keel, ft	9.5	0.40
Hull:		
Length, ft	91.78	3.83
Maximum beam, ft	10.33	0.43
Height, ft	13	0.54
Angle of dead rise, deg	30	30
Length-beam ratio	8.88	8.88
Wing:		
Area, sq ft	1,600	2.78
Span, ft	98	4.08
Sweepback of 25 percent chord line, deg	35	35
Airfoil section	NACA 64A410	NACA 64A410
Incidence, deg	3	3
Mean aerodynamic chord, ft	17.33	0.72
Root chord, ft	23.33	0.97
Tip chord, ft	9.34	0.39
Aspect ratio	6	6
Flap landing position, deg	50	50
Horizontal tail:		
Area, sq ft	384	0.69
Span, ft	41.5	1.73
Elevator area, sq ft	139	0.24
Vertical tail:		
Area, sq ft	240	0.42
Hydro-ski:		
Length, ft	21.28	0.89
Beam, ft	5.32	0.222
Area, sq ft	100	0.17
Length-beam ratio	4	4
Gross loading, lb/sq ft	1,600	66.7
Gross-load coefficient, C_{Δ_0}	16.8	16.8
Shock-absorber strut:		
Stroke, in.	24	1
Piston diameter, in.	10.5	0.44
Air-volume ratio	3	3
Initial air pressure, lb/sq in.	1,224	51
Extension rate, fps	6	1.22

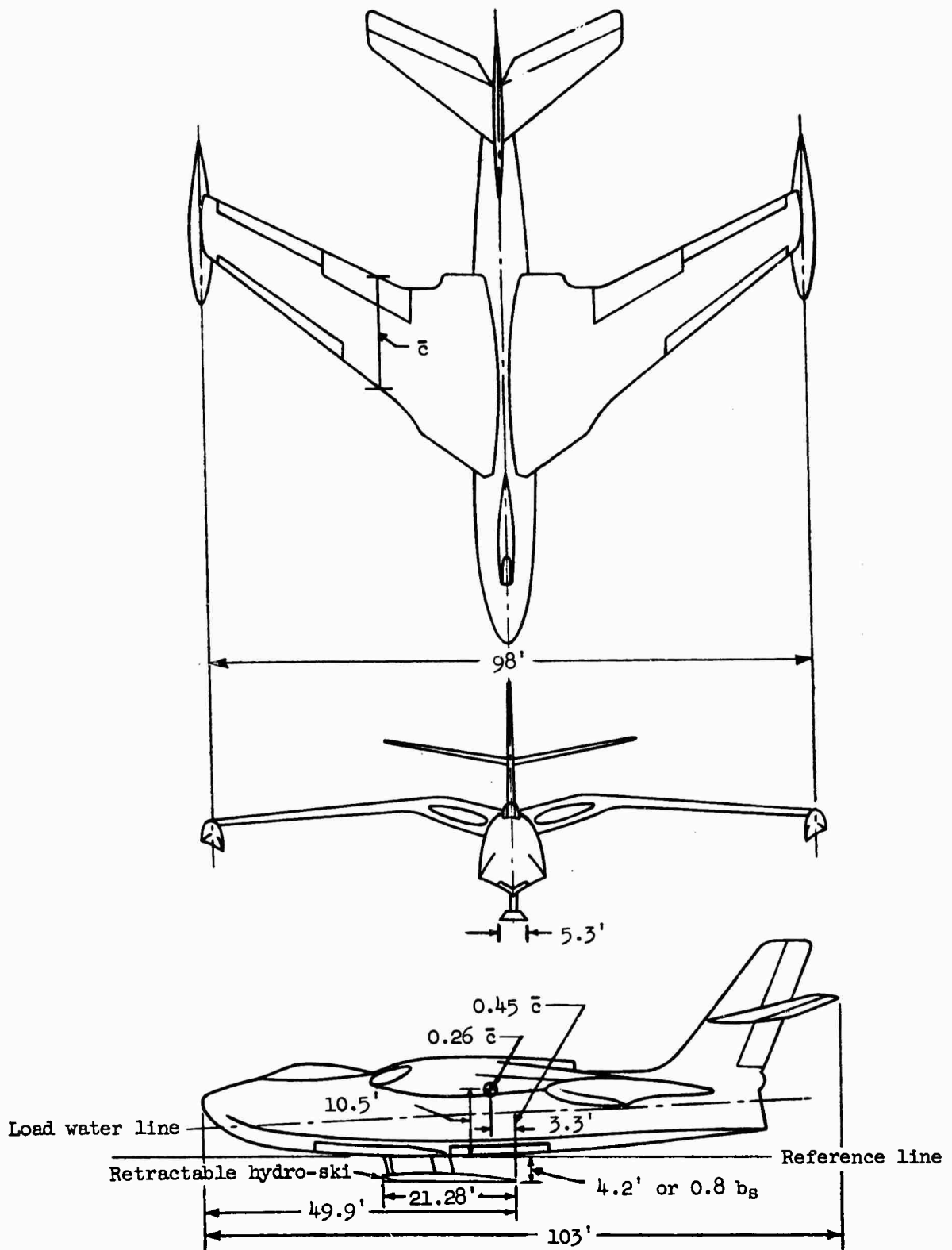
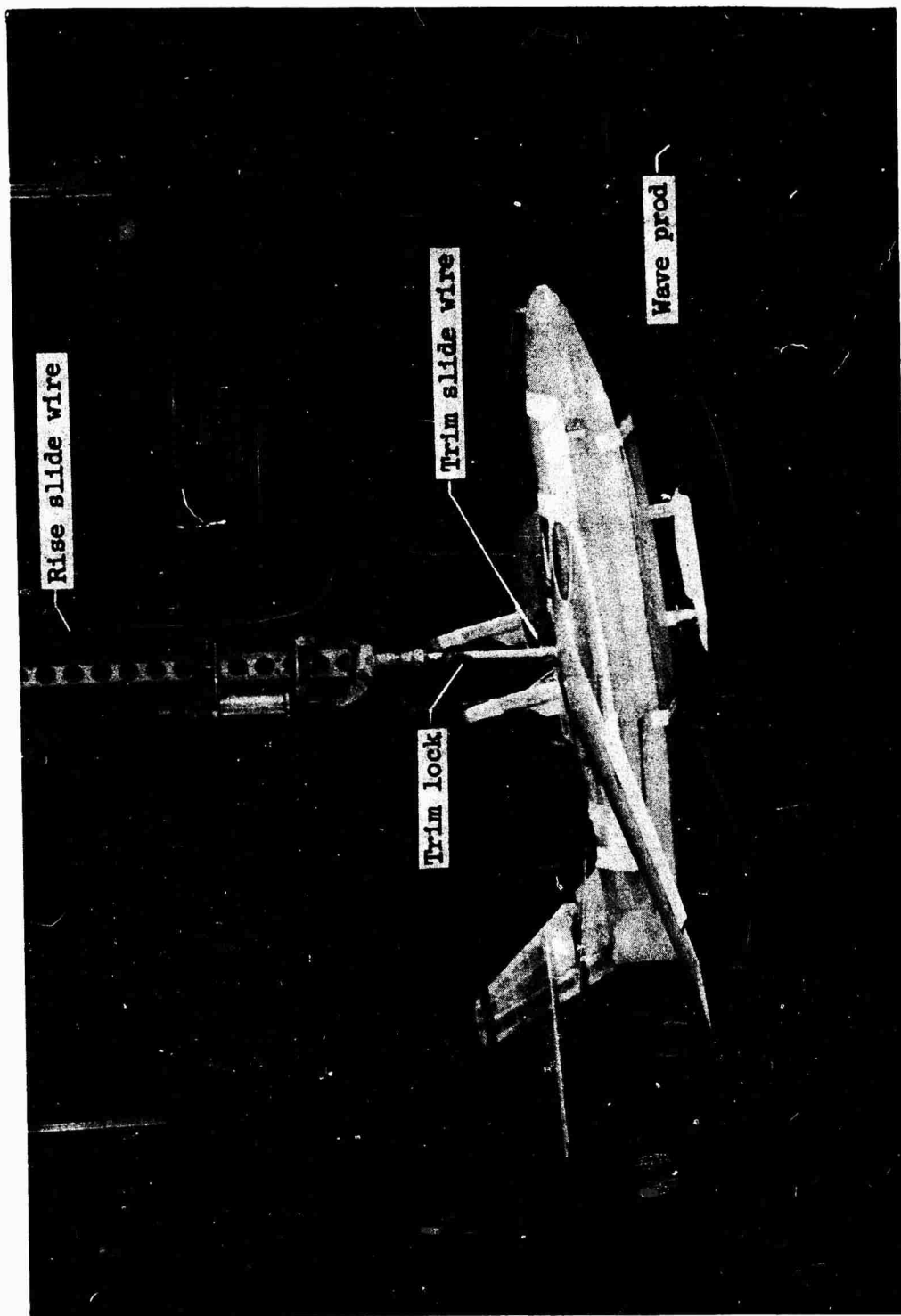

Figure 1.- General arrangement of full-scale seaplane design.



L-81784.1

Figure 2.- Setup of Langley tank model 280 on fore-and-aft gear.

PNEUMATIC SERVOACTUATOR



RATE-GYRO SENSING ELEMENT



Figure 3.- Artificial-trim stabilization control. L-86487

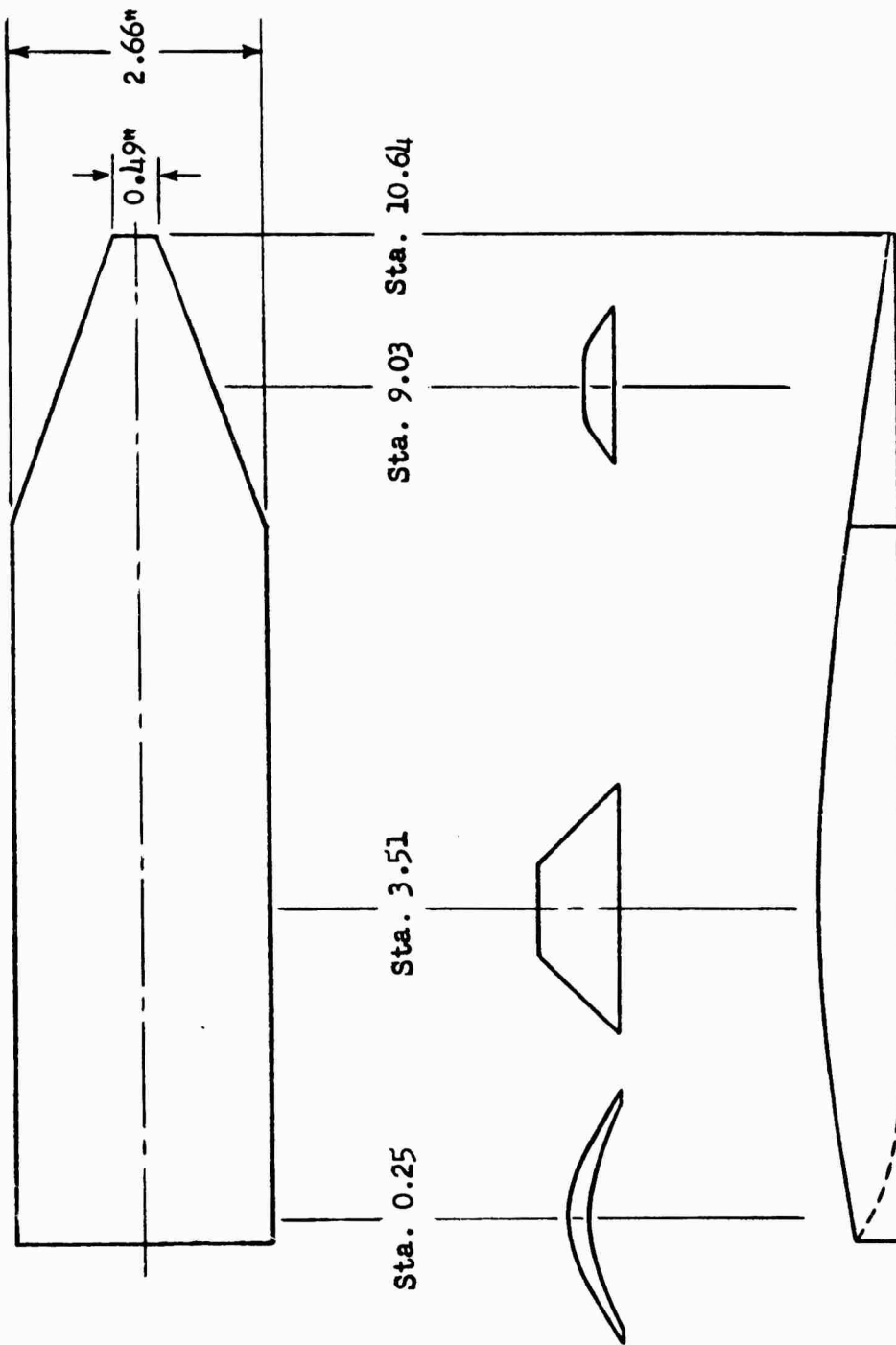
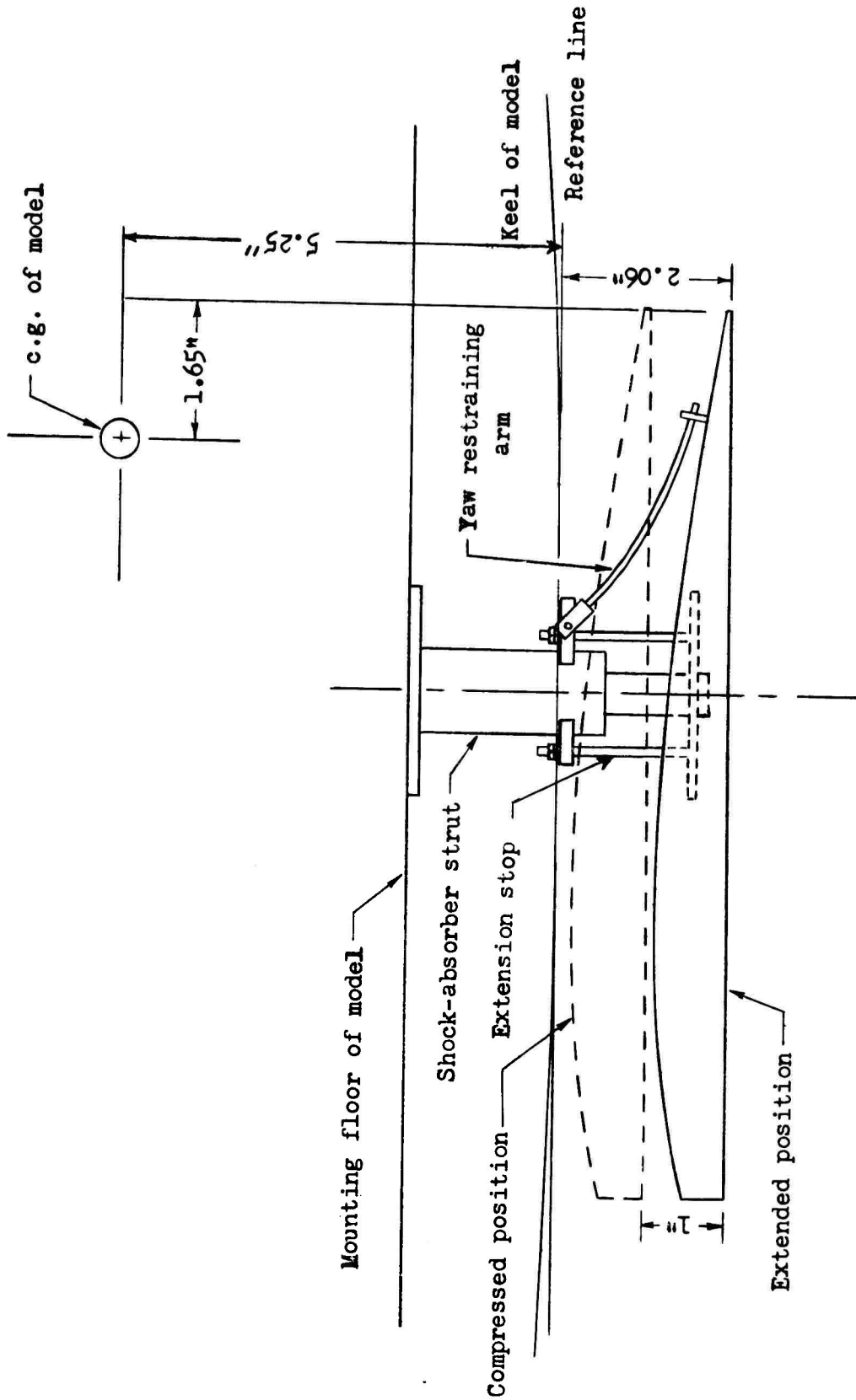
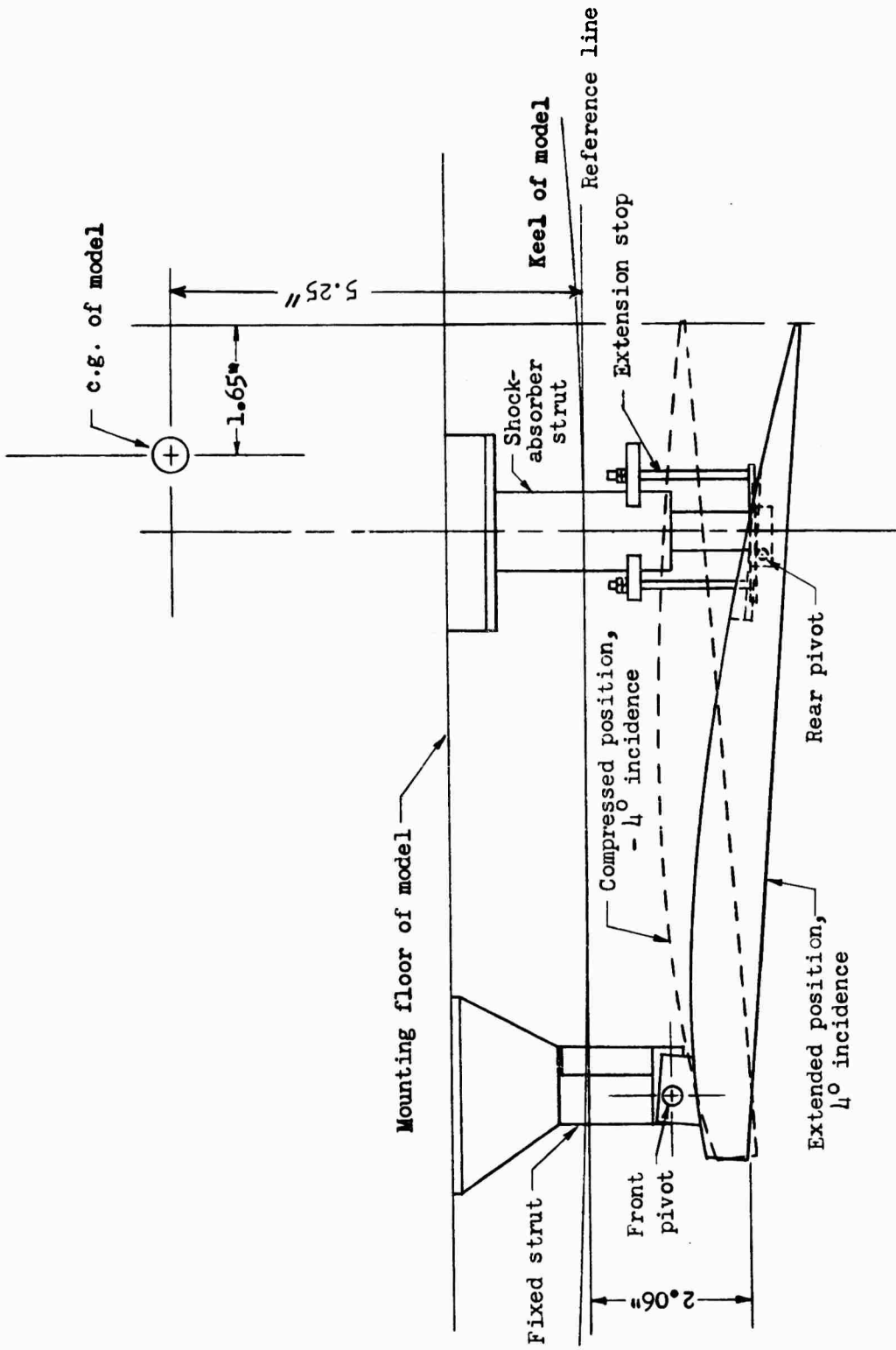

Figure 4.- Flat-bottom hydro-ski of Langley tank model 280.



(a) Translating ski.

Figure 5.- Hydro-ski-strut configurations.



(b) Pivoting ski.
Figure 5.- Concluded.

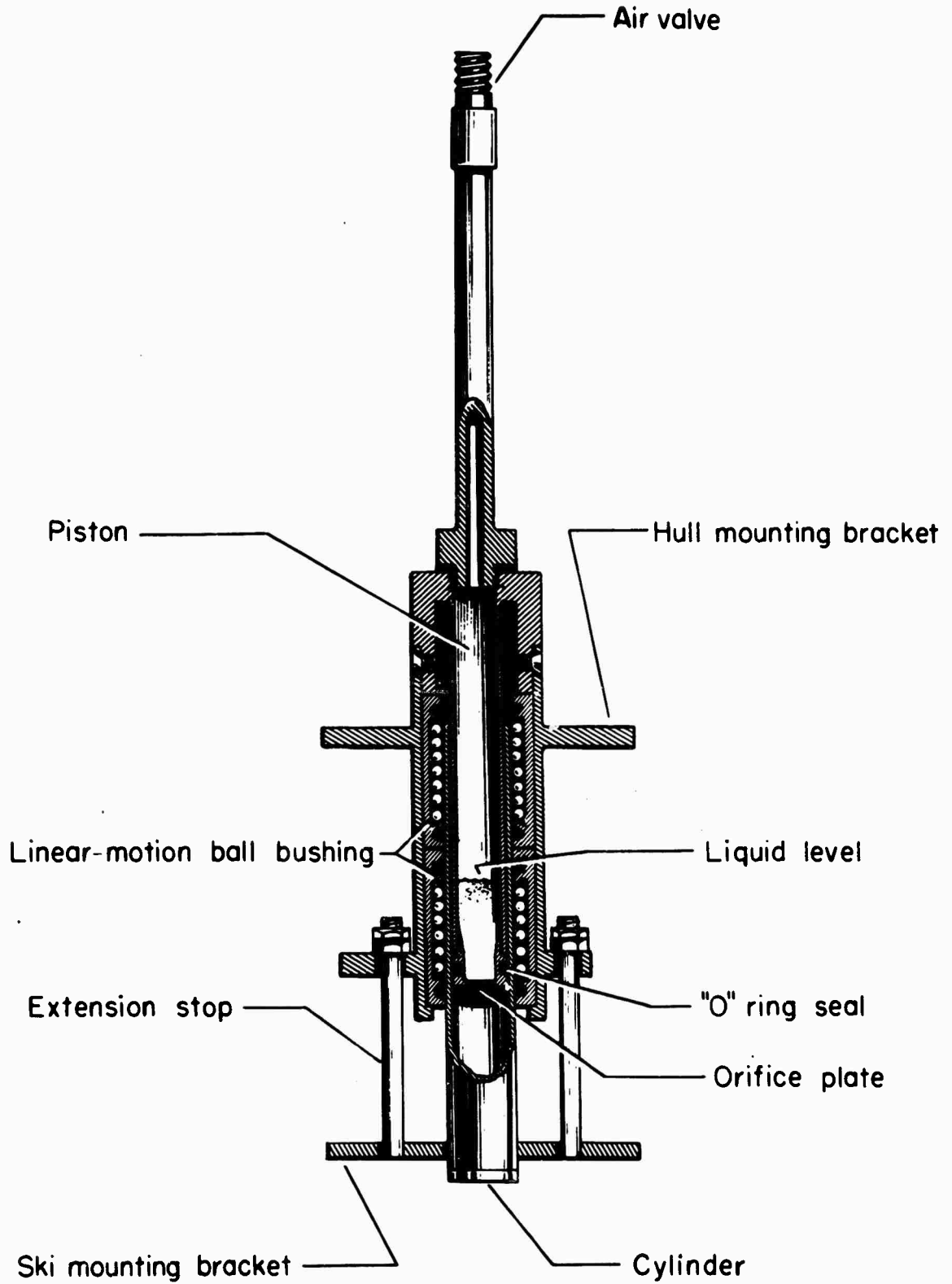
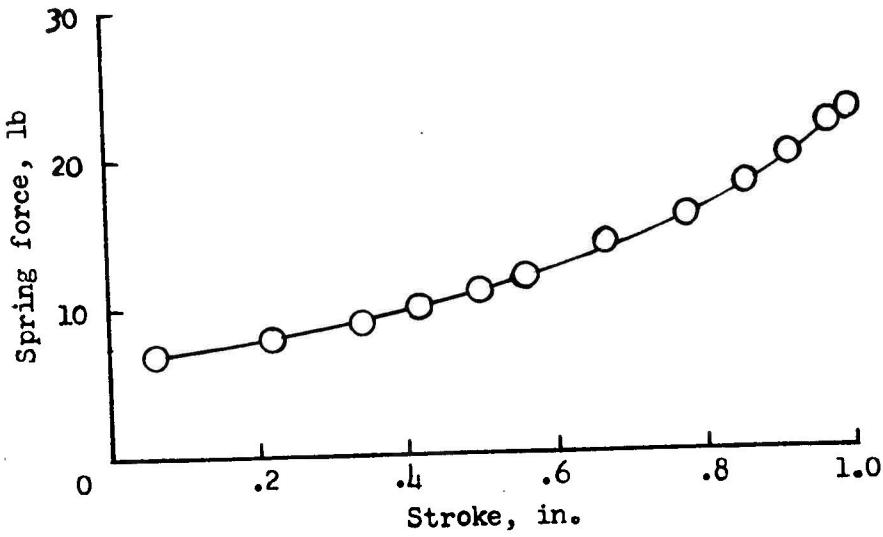
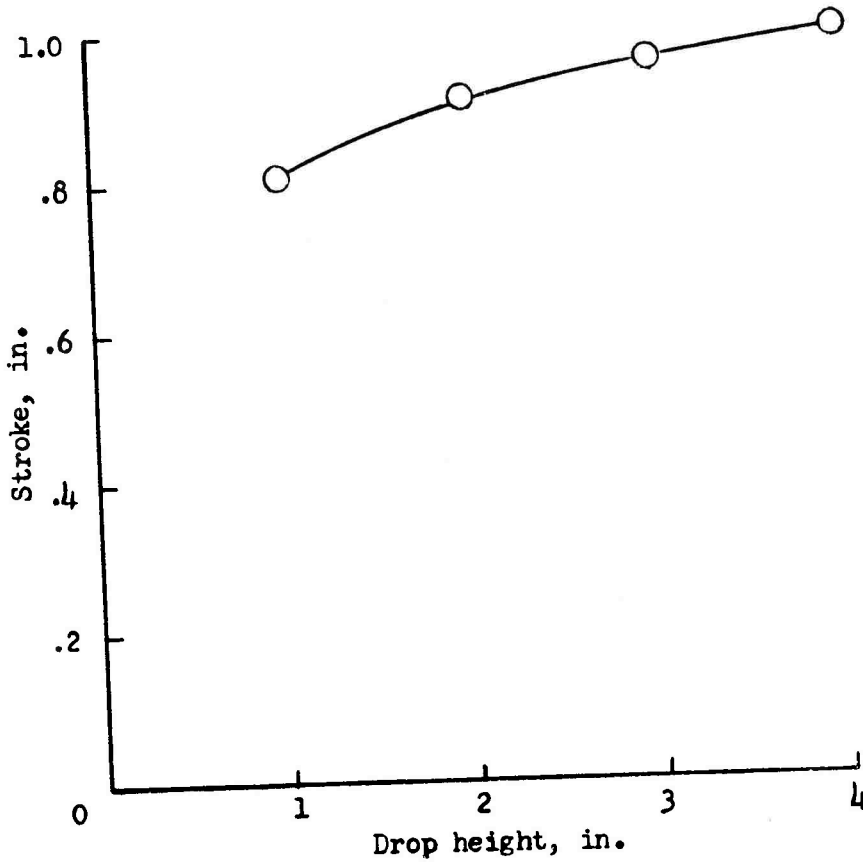

Figure 6.- Shock-absorber strut.



(a) Force-stroke diagram.



(b) Stroke-drop height diagram for a drop weight of 11.57 pounds.
Figure 7.- Shock-absorber characteristics obtained from bench tests.

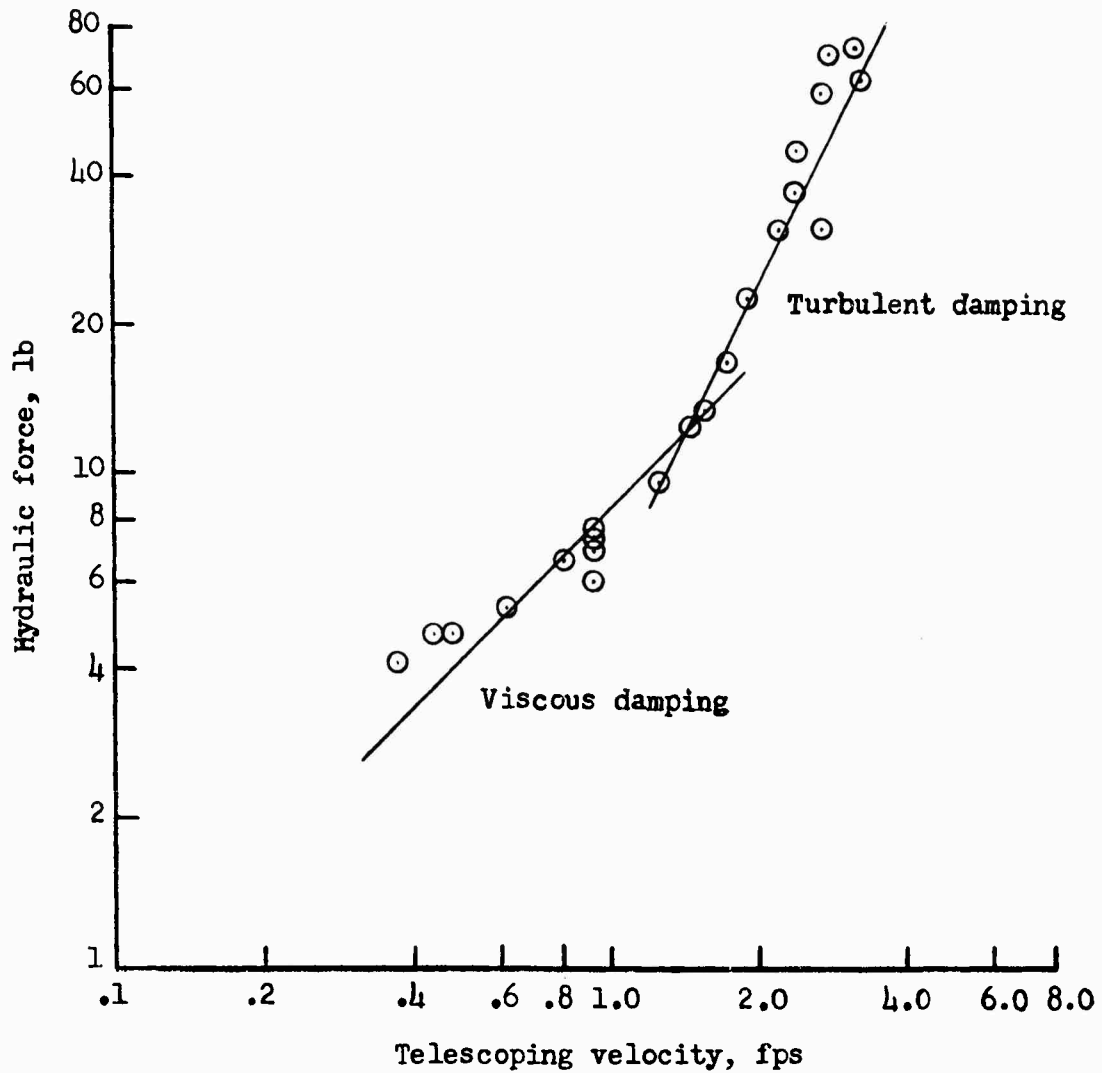

(c) Hydraulic force against telescoping velocity. Drop weight, 11.57 lb; drop height, 4 in.

Figure 7.- Concluded.

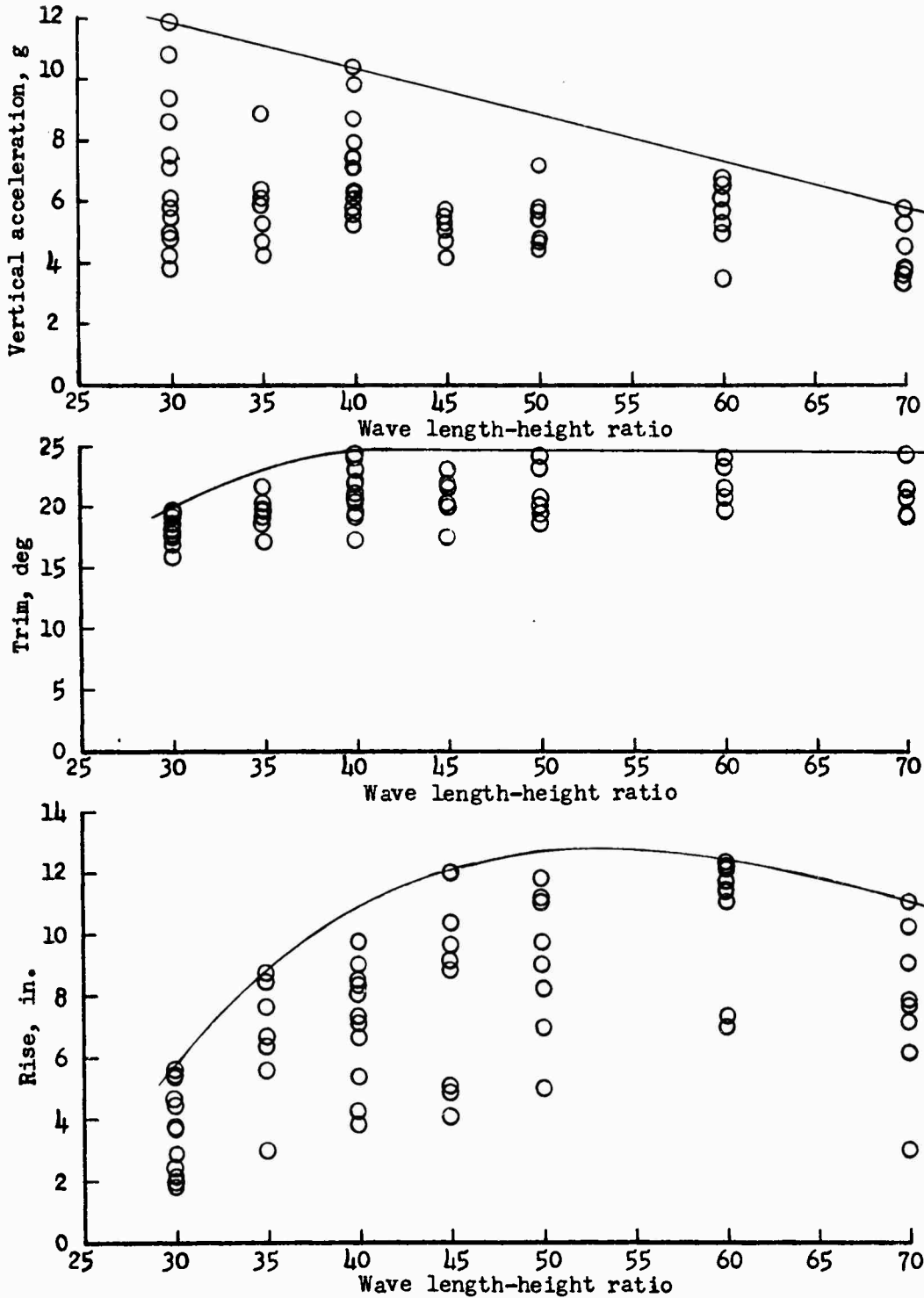

(a) Fixed ski.

Figure 8.- Maximum values of acceleration, trim, and rise at various wave length-height ratios. $\tau = 9^\circ$; $H_w = 3$ in.; stabilized trim. (Both hull and hydro-ski impacts are included.)

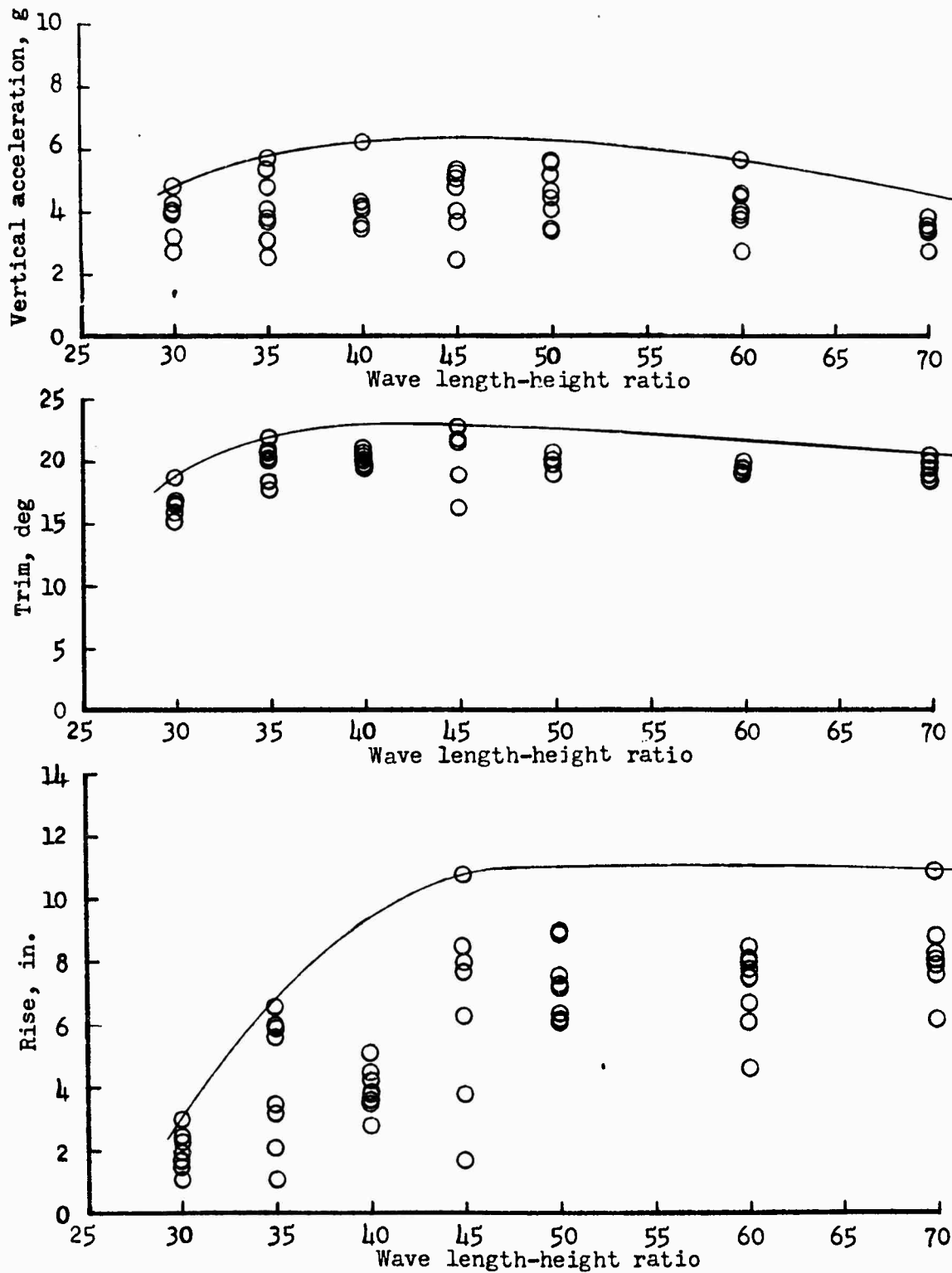

(b) Translating ski.

Figure 8.- Continued.

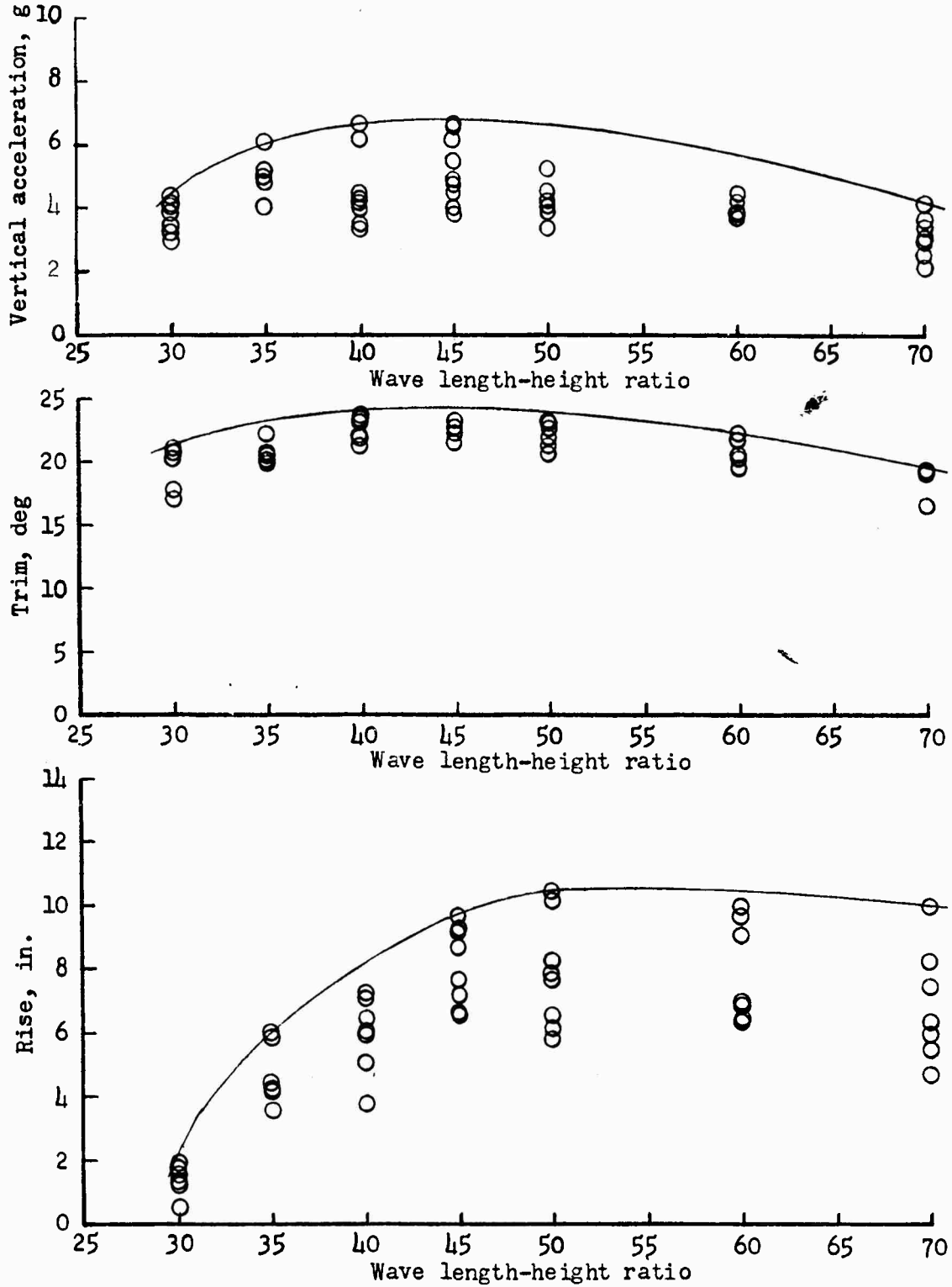

(c) Pivoting ski.

Figure 8.- Concluded.

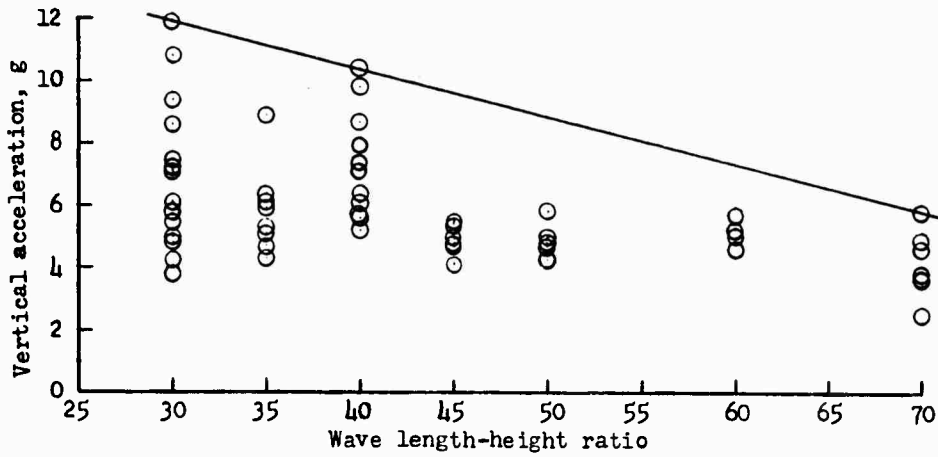

(a) Fixed ski.

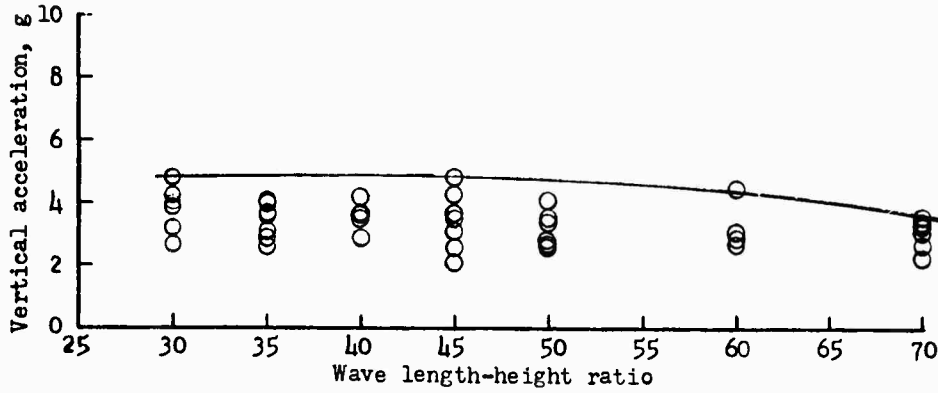

(b) Translating ski.

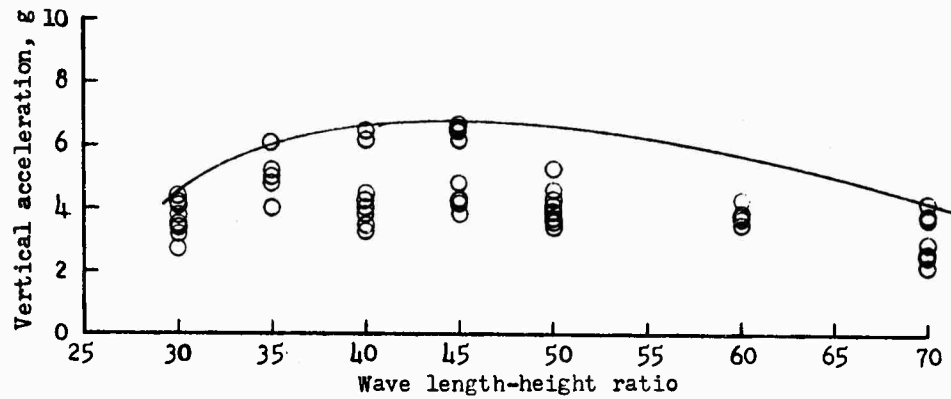

(c) Pivoting ski.

Figure 9.- Maximum acceleration of hydro-ski impacts at various wave length-height ratios. $\tau = 9^\circ$; $H_w = 3$ in.; stabilized trim.

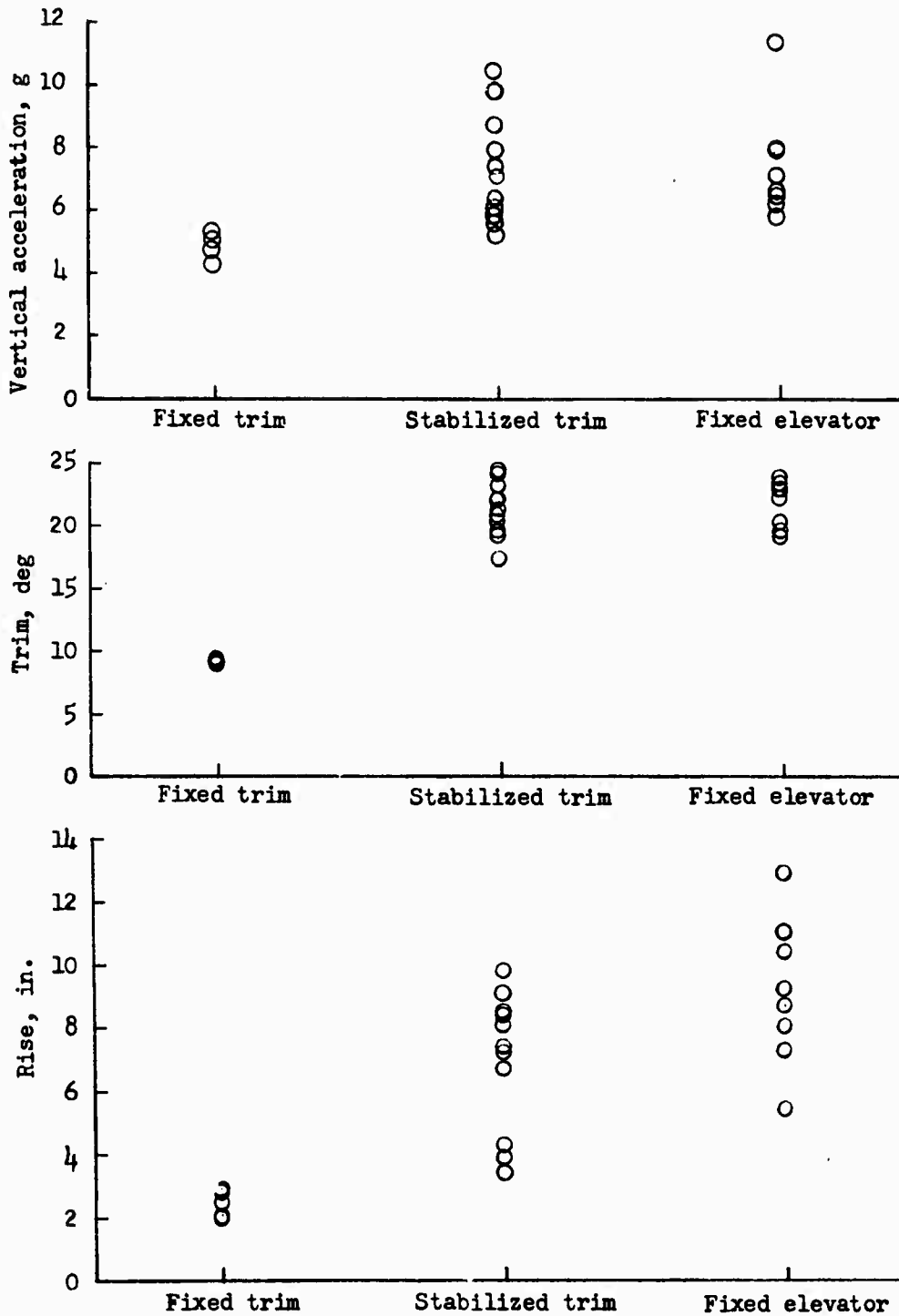

(a) Fixed ski.

Figure 10.- Maximum values of acceleration, trim, and rise for three conditions of trim control. $\tau = 9^\circ$; $H_w = 3$ in.; $L_w/H_w = 40$. (Both hull and hydro-ski impacts are included.)

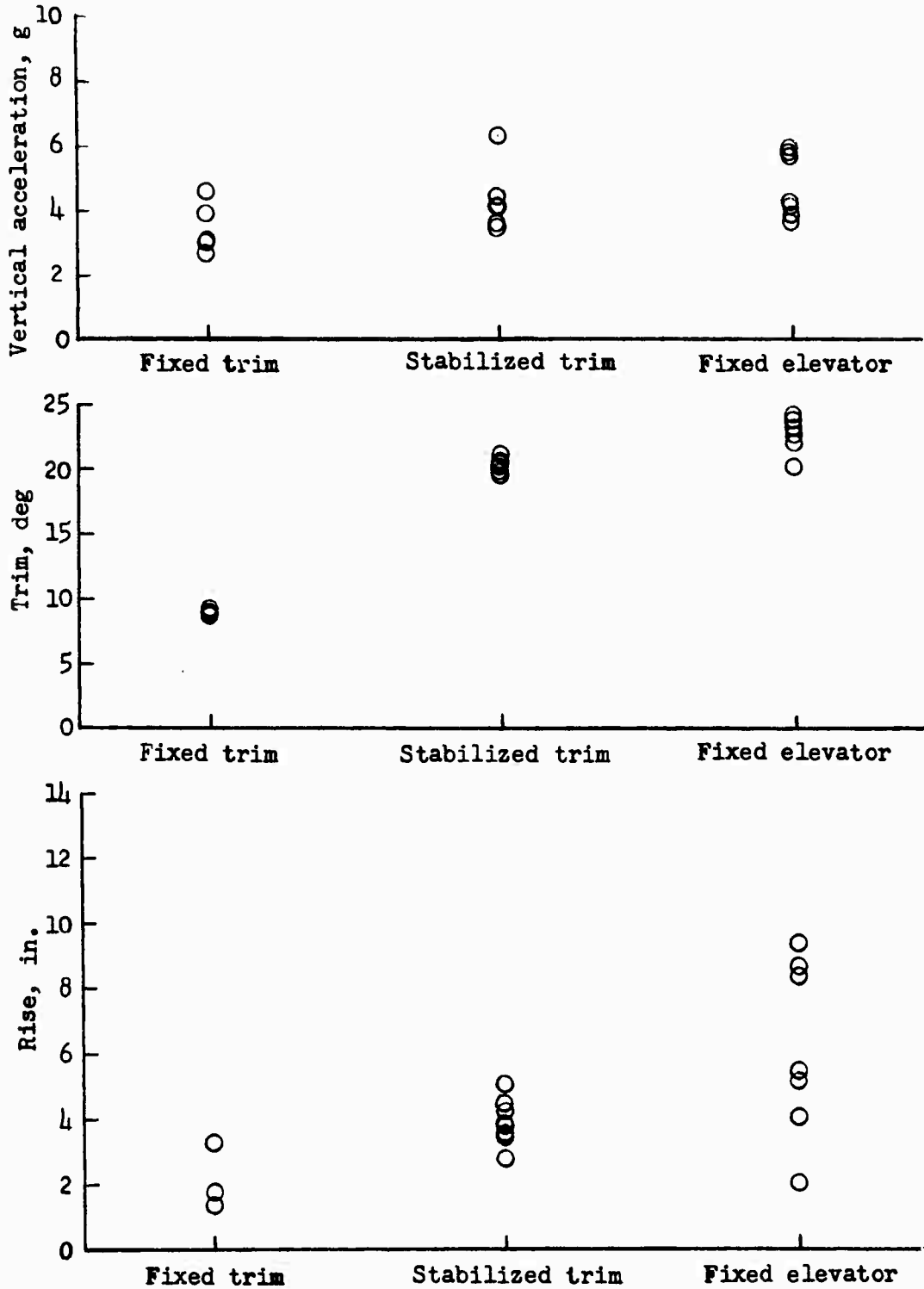

(b) Translating ski.

Figure 10.- Continued.

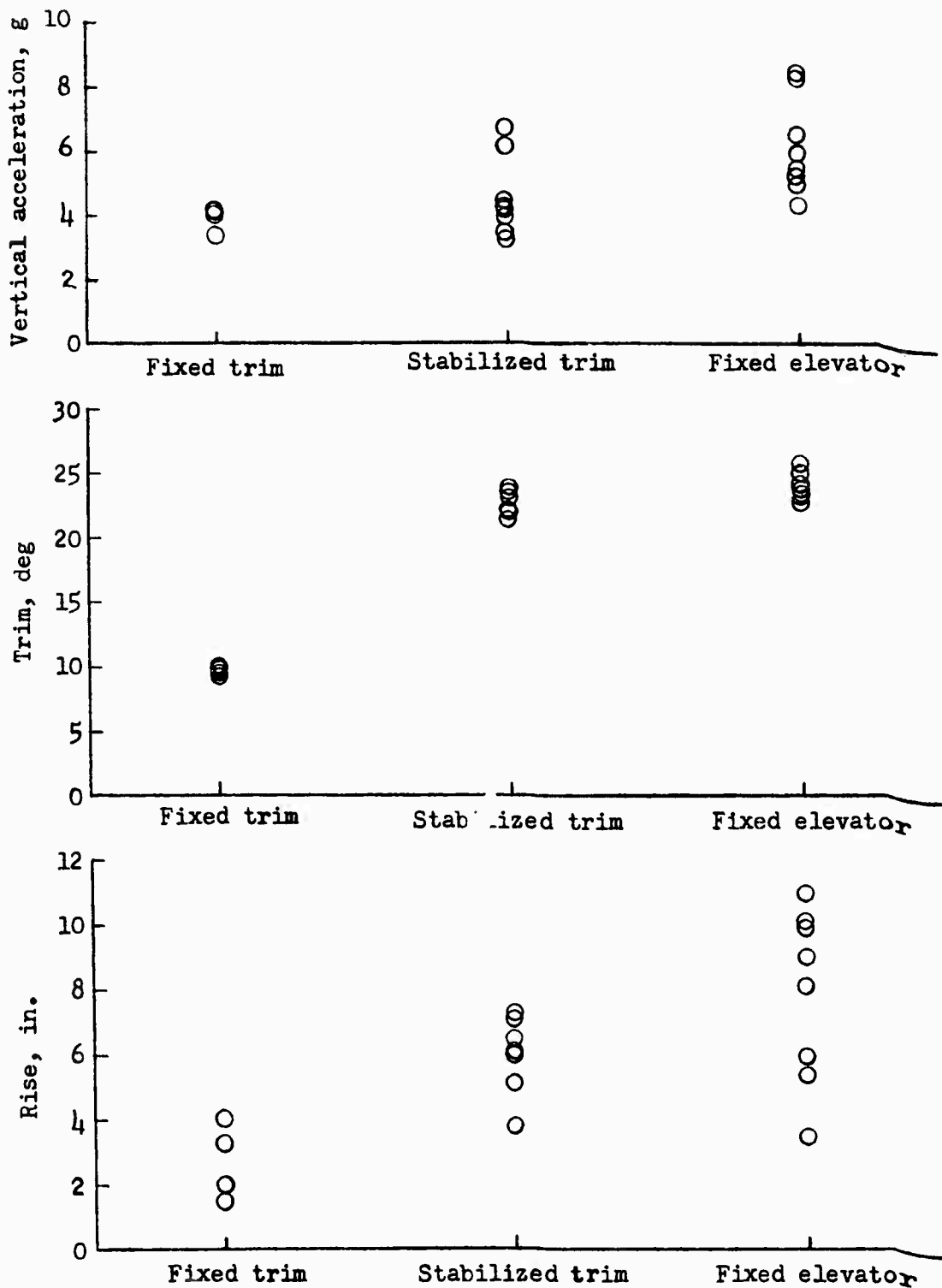

(c) Pivoting ski.

Figure 10.- Concluded.

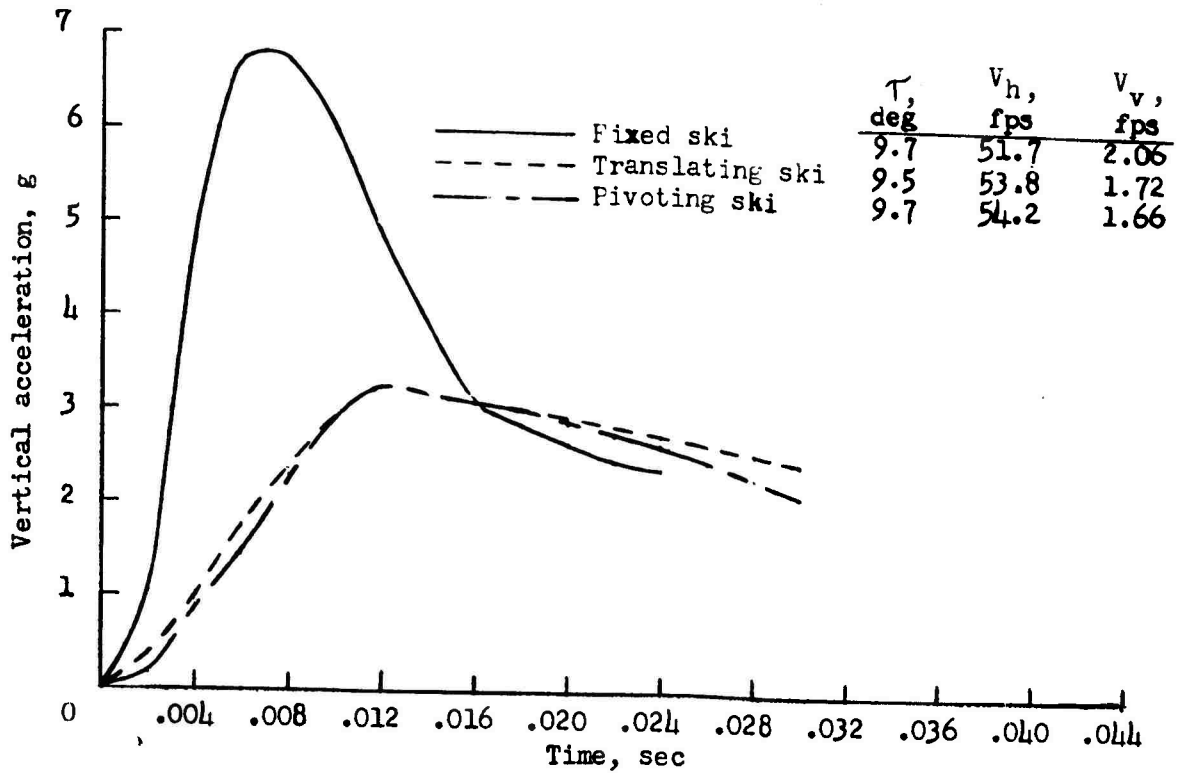

(a) Wave length-height ratio, 40.

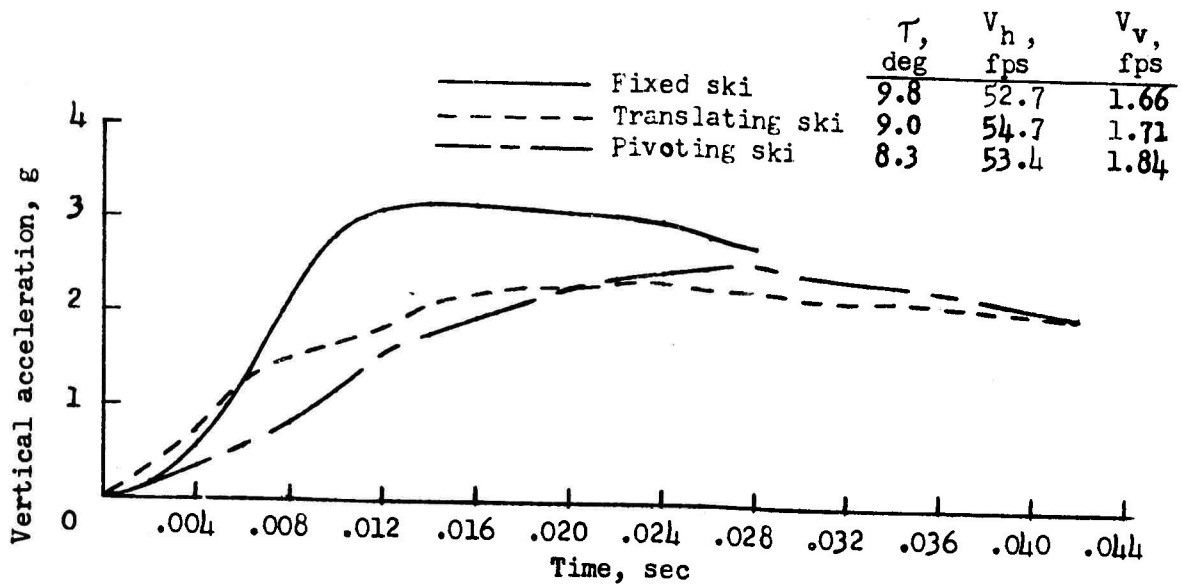

(b) Wave length-height ratio, 70.

Figure 11.- Typical time histories of vertical accelerations of hydro-ski impacts. $H_w = 3$ in.; stabilized trim.

NACA RM L54L02
National Advisory Committee for Aeronautics.
MODEL INVESTIGATION OF THE EFFECT OF
MOUNTING HYDRO-SKIS ON SHOCK ABSORBERS.
Edward L. Hoffman and Lloyd J. Fisher.
March 1955. 25p. diagrs., photos., tab. (NACA
RM L54L02) CONFIDENTIAL

A rough-water landing investigation of a model of a hydro-ski seaplane design was conducted to determine the effect on landing motions and vertical accelerations of mounting the hydro-ski on shock-absorber struts. The tests were made at one landing trim and wave height over a range of wave length for three hydro-ski configurations (fixed, translating, and pivoting). In addition, the effect of stabilizing the model in trim was investigated. The data are presented in plots of maximum vertical acceleration, rise, and trim against wave length-height ratio and against three conditions of trim control. The plots include hull impacts as well as hydro-ski

Copies obtainable from NACA, Washington (over)

CONFIDENTIAL

1. Hydrodynamic Configurations - General Studies (2. 2)
2. Planing Surfaces, Hydrodynamic (2. 6)
3. Stability and Control, Longitudinal - Hydrodynamic (2. 10. 1)
4. Loads, Landing - Impact, Water (4. 1. 2. 1. 2)
- I. Hoffman, Edward L.
- II. Fisher, Lloyd J.
- III. NACA RM L54L02



CONFIDENTIAL

NACA RM L54L02
National Advisory Committee for Aeronautics.
MODEL INVESTIGATION OF THE EFFECT OF
MOUNTING HYDRO-SKIS ON SHOCK ABSORBERS.
Edward L. Hoffman and Lloyd J. Fisher.
March 1955. 25p. diagrs., photos., tab. (NACA
RM L54L02) CONFIDENTIAL

A rough-water landing investigation of a model of a hydro-ski seaplane design was conducted to determine the effect on landing motions and vertical accelerations of mounting the hydro-ski on shock-absorber struts. The tests were made at one landing trim and wave height over a range of wave length for three hydro-ski configurations (fixed, translating, and pivoting). In addition, the effect of stabilizing the model in trim was investigated. The data are presented in plots of maximum vertical acceleration, rise, and trim against wave length-height ratio and against three conditions of trim control. The plots include hull impacts as well as hydro-ski

Copies obtainable from NACA, Washington (over)

CONFIDENTIAL

1. Hydrodynamic Configurations - General Studies (2. 2)
2. Planing Surfaces, Hydrodynamic (2. 6)
3. Stability and Control, Longitudinal - Hydrodynamic (2. 10. 1)
4. Loads, Landing - Impact, Water (4. 1. 2. 1. 2)
- I. Hoffman, Edward L.
- II. Fisher, Lloyd J.
- III. NACA RM L54L02



CONFIDENTIAL

CONFIDENTIAL

1. Hydrodynamic Configurations - General Studies (2. 2)
2. Planing Surfaces, Hydrodynamic (2. 6)
3. Stability and Control, Longitudinal - Hydrodynamic (2. 10. 1)
4. Loads, Landing - Impact, Water (4. 1. 2. 1. 2)
- I. Hoffman, Edward L.
- II. Fisher, Lloyd J.
- III. NACA RM L54L02



CONFIDENTIAL

NACA RM L54L02
National Advisory Committee for Aeronautics.
MODEL INVESTIGATION OF THE EFFECT OF
MOUNTING HYDRO-SKIS ON SHOCK ABSORBERS.
Edward L. Hoffman and Lloyd J. Fisher.
March 1955. 25p. diagrs., photos., tab. (NACA
RM L54L02) CONFIDENTIAL

A rough-water landing investigation of a model of a hydro-ski seaplane design was conducted to determine the effect on landing motions and vertical accelerations of mounting the hydro-ski on shock-absorber struts. The tests were made at one landing trim and wave height over a range of wave length for three hydro-ski configurations (fixed, translating, and pivoting). In addition, the effect of stabilizing the model in trim was investigated. The data are presented in plots of maximum vertical acceleration, rise, and trim against wave length-height ratio and against three conditions of trim control. The plots include hull impacts as well as hydro-ski

Copies obtainable from NACA, Washington (over)

NACA RM L54L02
National Advisory Committee for Aeronautics.
**MODEL INVESTIGATION OF THE EFFECT OF
MOUNTING HYDRO-SKIS ON SHOCK ABSORBERS.**
Edward L. Hoffman and Lloyd J. Fisher.
March 1955. 25p. diags., photos., tab. (NACA
RM L54L02) CONFIDENTIAL

A rough-water landing investigation of a model of a hydro-ski seaplane design was conducted to determine the effect on landing motions and vertical accelerations of mounting the hydro-ski on shock-absorber struts. The tests were made at one landing trim and wave height over a range of wave length for three hydro-ski configurations (fixed, translating, and pivoting). In addition, the effect of stabilizing the model in trim was investigated. The data are presented in plots of maximum vertical acceleration, rise, and trim against wave length-height ratio and against three conditions of trim control. The plots include hull impacts as well as hydro-ski

Copies obtainable from NACA, Washington (over)

CONFIDENTIAL

1. Hydrodynamic Configurations - General Studies (2. 2)
 2. Planing Surfaces, Hydrodynamic (2. 6)
 3. Stability and Control, Longitudinal - Hydrodynamic (2. 10. 1)
 4. Loads, Landing - Impact, Water (4. 1. 2. 1. 2)
- I. Hoffman, Edward L.
 - II. Fisher, Lloyd J.
 - III. NACA RM L54L02



CONFIDENTIAL

NACA RM L54L02
National Advisory Committee for Aeronautics.
**MODEL INVESTIGATION OF THE EFFECT OF
MOUNTING HYDRO-SKIS ON SHOCK ABSORBERS.**
Edward L. Hoffman and Lloyd J. Fisher.
March 1955. 25p. diags., photos., tab. (NACA
RM L54L02) CONFIDENTIAL

A rough-water landing investigation of a model of a hydro-ski seaplane design was conducted to determine the effect on landing motions and vertical accelerations of mounting the hydro-ski on shock-absorber struts. The tests were made at one landing trim and wave height over a range of wave length for three hydro-ski configurations (fixed, translating, and pivoting). In addition, the effect of stabilizing the model in trim was investigated. The data are presented in plots of maximum vertical acceleration, rise, and trim against wave length-height ratio and against three conditions of trim control. The plots include hull impacts as well as hydro-ski

Copies obtainable from NACA, Washington (over)

CONFIDENTIAL

1. Hydrodynamic Configurations - General Studies (2. 2)
 2. Planing Surfaces, Hydrodynamic (2. 6)
 3. Stability and Control, Longitudinal - Hydrodynamic (2. 10. 1)
 4. Loads, Landing - Impact, Water (4. 1. 2. 1. 2)
- I. Hoffman, Edward L.
 - II. Fisher, Lloyd J.
 - III. NACA RM L54L02



CONFIDENTIAL

NACA RM L54L02
National Advisory Committee for Aeronautics.
**MODEL INVESTIGATION OF THE EFFECT OF
MOUNTING HYDRO-SKIS ON SHOCK ABSORBERS.**
Edward L. Hoffman and Lloyd J. Fisher.
March 1955. 25p. diags., photos., tab. (NACA
RM L54L02) CONFIDENTIAL

A rough-water landing investigation of a model of a hydro-ski seaplane design was conducted to determine the effect on landing motions and vertical accelerations of mounting the hydro-ski on shock-absorber struts. The tests were made at one landing trim and wave height over a range of wave length for three hydro-ski configurations (fixed, translating, and pivoting). In addition, the effect of stabilizing the model in trim was investigated. The data are presented in plots of maximum vertical acceleration, rise, and trim against wave length-height ratio and against three conditions of trim control. The plots include hull impacts as well as hydro-ski

Copies obtainable from NACA, Washington (over)

CONFIDENTIAL

1. Hydrodynamic Configurations - General Studies (2. 2)
 2. Planing Surfaces, Hydrodynamic (2. 6)
 3. Stability and Control, Longitudinal - Hydrodynamic (2. 10. 1)
 4. Loads, Landing - Impact, Water (4. 1. 2. 1. 2)
- I. Hoffman, Edward L.
 - II. Fisher, Lloyd J.
 - III. NACA RM L54L02



CONFIDENTIAL

NACA RM L54L02
National Advisory Committee for Aeronautics.
**MODEL INVESTIGATION OF THE EFFECT OF
MOUNTING HYDRO-SKIS ON SHOCK ABSORBERS.**
Edward L. Hoffman and Lloyd J. Fisher.
March 1955. 25p. diags., photos., tab. (NACA
RM L54L02) CONFIDENTIAL

A rough-water landing investigation of a model of a hydro-ski seaplane design was conducted to determine the effect on landing motions and vertical accelerations of mounting the hydro-ski on shock-absorber struts. The tests were made at one landing trim and wave height over a range of wave length for three hydro-ski configurations (fixed, translating, and pivoting). In addition, the effect of stabilizing the model in trim was investigated. The data are presented in plots of maximum vertical acceleration, rise, and trim against wave length-height ratio and against three conditions of trim control. The plots include hull impacts as well as hydro-ski

Copies obtainable from NACA, Washington (over)

CONFIDENTIAL

1. Hydrodynamic Configurations - General Studies (2. 2)
 2. Planing Surfaces, Hydrodynamic (2. 6)
 3. Stability and Control, Longitudinal - Hydrodynamic (2. 10. 1)
 4. Loads, Landing - Impact, Water (4. 1. 2. 1. 2)
- I. Hoffman, Edward L.
 - II. Fisher, Lloyd J.
 - III. NACA RM L54L02



CONFIDENTIAL