

UNCLASSIFIED

AD NUMBER

AD065577

LIMITATION CHANGES

TO:

Approved for public release; distribution is unlimited.

FROM:

Distribution authorized to U.S. Gov't. agencies and their contractors;
Administrative/Operational Use; 07 AUG 1931.
Other requests shall be referred to National Aeronautics and Space Administration, Washington, DC.

AUTHORITY

NASA TR Server website

THIS PAGE IS UNCLASSIFIED

REPORT No. 406

DROP AND FLIGHT TESTS ON NY-2 LANDING GEARS INCLUDING MEASUREMENTS OF VERTICAL VELOCITIES AT LANDING

By W. C. PECK and A. P. BEARD

SUMMARY

This investigation was conducted at the request of the Bureau of Aeronautics, Navy Department, to obtain quantitative information on the effectiveness of three landing gears for the "NY-2" (Consolidated training) airplane. The investigation consisted of static, drop, and flight tests on landing gears of the oleo-rubber-disk and the "Mercury" rubber-cord types, and flight tests only on a landing gear of the conventional split-axle rubber-cord type.

The results show that the oleo gear is the most effective of the three landing gears in minimizing impact forces and in dissipating the energy taken. The flight results indicate that in pancake landings with a vertical velocity at contact of 8 feet per second the maximum accelerations experienced are approximately 3.2g, 4.9g, and 4.4g with the oleo, the Mercury, and the split-axle rubber-cord gears, respectively.

The results also show that, in the good landings, larger impact forces were experienced subsequent to contact (generally less than 2.8g) than experienced at contact (generally less than 2.0g).

The oleo landing gear permitted severe landings to be made without violent rebound, but the Mercury and the split-axle rubber-cord gears caused very violent and dangerous rebounds.

A comparison of the results of the drop tests, based upon equal heights of free drops, does not show the relative merits of the landing gears as realized in flight tests. However, a comparison made upon a basis of equal heights of total drop (free drop plus vertical movement of the load during the initial stroke of the landing gear) is indicative of them.

INTRODUCTION

A series of tests was started in 1929 at the request of the Bureau of Aeronautics, Navy Department, to determine quantitatively the relative shock-absorbing and energy-dissipating merits of both rubber and oleo types of landing gears, with a view to the possibility of redesigning the structure affected by the loads imposed in landing. To date, three of these investigations have been completed at the Langley Memorial Aeronautical Laboratory, Langley Field, Va. Reference 1 gives the results of the first investigation, tests on two F6C-4

landing gears; reference 2, those of the second investigation, tests on a pair of air wheels. The third investigation, reported herein, was conducted during the period from May, 1930, to February, 1931, and consisted of static, drop, and flight tests on two NY-2 landing gears and flight tests only on a third.

The static tests were made to determine the depressions and compressions or elongations of the various elastic units of the shock-absorbing systems under static loads. The drop tests were made to obtain information on the depressions of the tires, the elongations of the rubber cords, the compressions of the rubber disks, the pressures built up in the oleo cylinders, the work done on the various units, the degree of rebound, and the maximum accelerations experienced

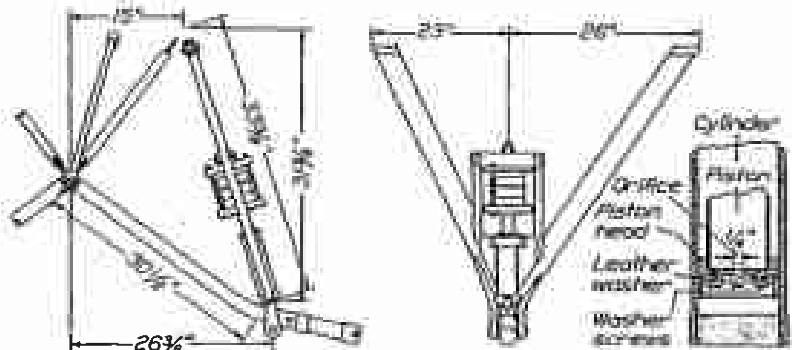

FIGURE 1.—Oleo-rubber-disk type of landing-gear chassis

under impact forces. The flight tests were made to determine the maximum accelerations and the vertical velocities of the airplane during different types of landings.

APPARATUS

Landing gears.—The landing gears subjected to tests in this investigation were an oleo-rubber-disk type (figs. 1 and 2), a Mercury rubber-cord type (figs. 3 and 4), and a split-axle rubber-cord type (fig. 5). The respective weights of these landing gears, less wheels and tires, were 94 pounds, 80 pounds, and 65 pounds. These landing gears were constructed for use on an NY-2 (Consolidated Naval Training) airplane and during the flight tests were mounted successively on this airplane.

loadings of 2,690 and 2,530 pounds, respectively, for the Mercury and the oleo landing gears. The tests were carried to such a point that further increase in the height of free drop probably would have resulted in failure of the landing gears. During the tests on both gears the height of free drop, the total vertical displacement of the load, the rebound, the elongation of the rubber cords, or the compressions of the rubber disks, and the maximum accelerations (in multiples of the static load) were recorded. With the oleo gear, records of the stroke of the oleo cylinder and the pressures built up in it were also made.

The test rig (described in reference 1), two control-position recorders, a pressure-displacement recorder, a recording accelerometer, and a timer were used during the drop tests.

One control-position recorder (reference 5) was used during all the drop tests, in conjunction with a suitable reduction linkage, to record the vertical displacement of the load. A second control-position recorder was used during the drop tests on the Mercury gear only, to record the elongation of the rubber cords.

The recording accelerometer, a single-component type (reference 5), was mounted on the load platform of the test rig with its actuating mechanism in the vertical plane containing the center of gravity of the load. This instrument was used to record the ratio between the static load and the impact forces at the *c. g.* of the load.

The timer (reference 6), a commutator circuit-breaker-type instrument, was used to provide a time scale on the instrument records.

The pressure-displacement recorder (fig. 6), a modified air-speed recorder, was used to record the pressures built up in the oleo cylinder and the displacement of the oleo cylinder with respect to the piston. The recording range of the instrument was 0 to 2,000 pounds per square inch. The records obtained with this instrument gave the relative displacement of the oleo cylinder as abscissa and pressures as ordinates.

Flight tests.—The flight tests were made with the landing gears successively mounted on an NY-2 airplane (weight approximately 2,700 pounds). The tests consisted of normal (3-point), tail-high (2-point), and "pancake" landings and take-off and taxi runs, all of which were made on an average grass-covered landing field. The pancake landings were of two types—one in which the airplane was leveled off at approximately 5 feet above the ground and allowed to "drop" in, and the other one in which the landings were made by gliding onto the ground without any attempt being made to level off.

During these tests, records of the air speed, wind speed, vertical displacements, and accelerations developed were taken from the time the airplane was about 15 feet above the ground until a few seconds after

contact had been made. In the taxi and take-off runs, records were taken of the accelerations developed.

The instruments used during the flight tests were a control-position recorder, a motion-picture camera, a recording accelerometer, an air-speed recorder, an anemometer, and a timer.

The control-position recorder, mounted in the front cockpit of the airplane, was used in conjunction with a trailing arm to record the history of the vertical displacement of the airplane.

The trailing arm (figs. 2 and 7) had an over-all length of 16½ feet, but because it trailed to the rear in flight it did not make contact with the ground until the wheels of the airplane were within 10 feet of the ground.

The motion-picture camera was employed to record the attitude of the airplane at landing. At the outset of the flight tests the motion-picture camera was mounted on a tripod erected and leveled on the landing field about 50 yards from the path of the landing airplane, and was operated at 32 exposures per second. During the latter portion of the flight tests the camera was mounted in the forward cockpit of the airplane

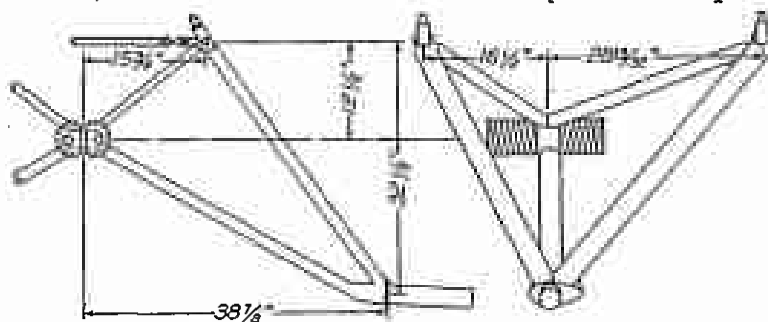

FIGURE 3.—Mercury (rubber-cord type) landing-gear chassis

and motion pictures of the horizon were taken at 16 exposures per second. These motion-picture records were used to correct the trailing-arm records for the change in attitude of the airplane during the time the arm was in contact with the ground. The instant of contact of the wheels with the ground, which was clearly indicated by the air-speed, accelerometer, and motion-picture records, was used to synchronize the records.

The accelerometer was mounted as close as practicable to the *c. g.* of the airplane, and was used to record the forces experienced in the landings. This instrument was the one used during the drop tests.

The timer, the one used during the drop tests, was employed to provide a time scale on the film records so that histories could be made.

The air-speed recorder (reference 4) was used during the flight tests in conjunction with a swiveling Pitot-static head to record the air speed of the airplane during the landings. The swiveling head was mounted one chord length ahead of the leading edge of the upper wing on a boom secured to the left interplane strut. (Fig. 7.) The air-speed recorder was secured in the forward cockpit of the airplane.

The anemometer, a vane-type instrument, was used to measure the average ground-wind velocity during the landings. It was mounted about 6 feet above the ground on a vane erected on that portion of the field whereon the landings were being made.

PRECISION

Static tests.—The accuracy with which the measurements were taken during the static tests was such that the errors in the results do not exceed 1 per cent.

Drop tests.—The records of the vertical displacement of the load (total drop) and the elongation of

Flight tests.—The accuracies of the records obtained from the instruments in the flight tests are of approximately the same order as those obtained in the drop tests.

Previous tests employing the combination swiveling Pitot-static head and air-speed recorder installed on an airplane in a manner similar to that employed in this investigation indicate that the error in recorded air speed does not exceed ± 4 per cent.

It is believed that the recorded value of the wind speed is within 3 miles per hour of the instantaneous wind speed at the time the airplane made contact with

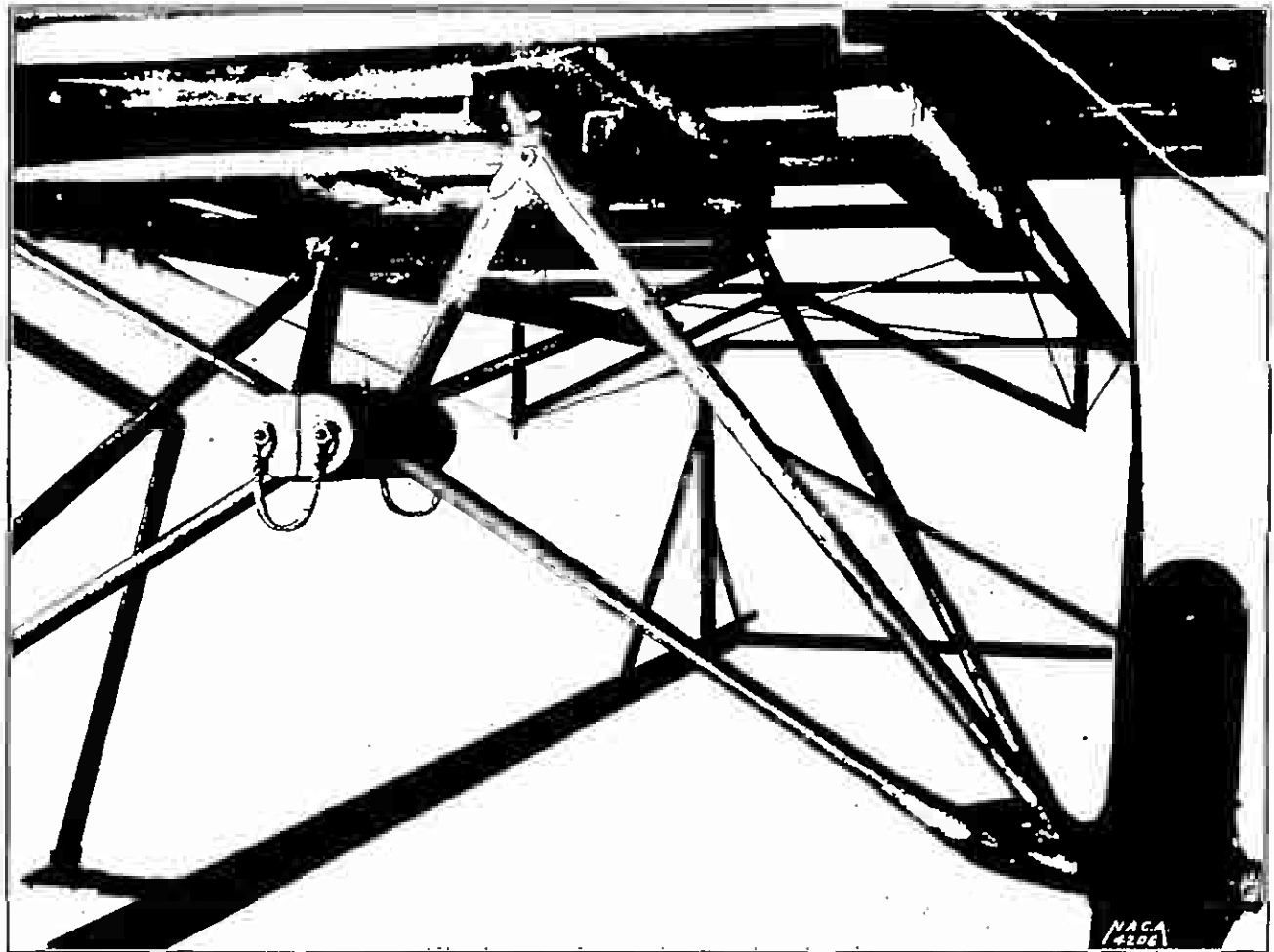

FIGURE 4.—Mercury landing gear mounted on test rig

the rubber cords are estimated to be accurate within ± 0.25 inch and ± 0.10 inch, respectively. The maximum compression of the rubber disks and, consequently, the maximum stroke of the oleo unit were indicated mechanically and measured within ± 0.01 inch. The pressures generated in the oleo cylinders were determined within ± 40 pounds per square inch.

The faired curves of maximum accelerations developed indicate that the accelerations recorded are correct within $\pm 0.25g$.

The time intervals recorded on all the instrument records were determined to be within ± 2 per cent.

with the ground. Thus, the computed ground speed at contact is believed to be correct within ± 5 miles per hour.

The change in attitude of the airplane during the landings while the airplane was within 10 feet of the ground was determined from the motion-picture records within $\frac{1}{2}^\circ$.

The indicated height of the airplane above the ground was recorded by the trailing-arm combination within ± 2 inches. It is estimated that this accuracy enabled the determination of the vertical velocity of the airplane within ± 0.5 foot per second.

RESULTS

General.—The total load on the landing gear in the static and drop tests was considered equally divided between the tires. In the calculation of the impact forces it was assumed that the instantaneous accelerations throughout the landing gear and at the center of the load platform were of the same magnitude. This assumption, obviously, is not exactly true; but, since the load used in these tests may be considered a concentrated mass and since the weight of the complete landing gear is small in comparison with the load used, the use of this assumption involves a very small or

the hydraulic unit and the instantaneous compressive load on the rubber disks.

The total work done on the landing gear during the drop tests was calculated by taking the product of the static load and its total vertical displacement during the drop. The work done on each of the shock-absorbing units was determined by taking the integral of the curve of instantaneous forces on it against the linear distortions of the unit during its first stroke.

Static tests.—The results of the static tests on the Mercury and the oleo gears are shown in Figures 8 and 9. The areas under the curves of increasing load



FIGURE 5.—Rubber-cord gear mounted on NY-2 airplanes

negligible error. By the use of the above assumptions, the maximum forces on the tire were calculated by multiplying the static load on the tire by the maximum acceleration at the center of the load. The load, on the elastic unit of the landing gear was calculated from the load on the tire and the geometric relation existing between the elastic unit and the tire. The load, or restraining force, set up in the hydraulic unit of the oleo gear was calculated by multiplying the effective piston area by the recorded pressure in the unit. The instantaneous load on the oleo unit was determined by taking the sum of the instantaneous retarding force set up by

indicate the capacity of the various units to receive energy. The areas under the curves of decreasing load represent the amount of energy returned by the unit in resuming its normal condition and is indicative of the tendency of the unit to cause bouncing. The difference between the areas under the curves of the increasing and the decreasing loads represents the energy dissipated by the unit. The results indicate that the rubber cords, the rubber disks, and the tires dissipated approximately 30 per cent, 30 per cent, and 10 per cent, respectively, of the total energy received by them.

Drop tests.—The results of the drop tests (figs. 10 to 18) furnish a means of comparing the action of landing gears under impact forces. Such a comparison should be made upon a basis of equal heights of total drop of the load. This is the same as making the comparison upon the basis of equal amounts of energy

in which the *c. g.* of the load was above the datum plane at the start of the drop; in those noted as negative the *c. g.* of the load was below the datum plane at the start of the drop.

The total drop is the vertical displacement of the *c. g.* of the load from the start of the drop to the maxi-

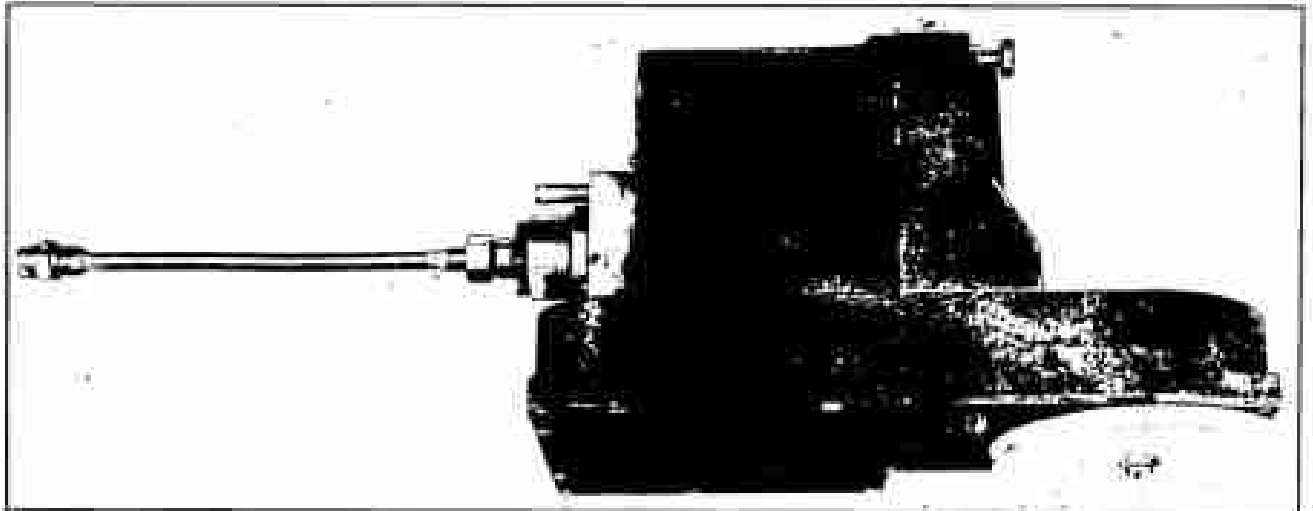

FIGURE 6.—Pressure-displacement recorder

received by the landing gears. For ease in the presentation and discussion of the results, a datum plane for zero height of free drop was established. This datum plane was the horizontal plane occupied by the center of gravity of the load when the test rig was in such position that the shock-absorbing units were completely

in maximum contraction of the shock-absorbing units. The total rebound is the vertical displacement of the *c. g.* of the load from maximum contraction of the shock-absorbing units to the crest of the first rebound. The free rebound is the vertical distance between the *c. g.* of the load at the crest of the first rebound and the



FIGURE 7.—NY-3 airplane with swivelling Pitot-static head and trailing arm installed

extended and the tires were merely in contact with the landing platform.

The free drop, noted in the results, is the vertical distance between this datum plane and the horizontal plane occupied by the *c. g.* of the load at the start of the drop. The free drops noted as positive are those

datum plane. Those noted as positive are from tests in which the position of the *c. g.* of the load at the crest of the rebound was above the datum plane while for those noted as negative the rebound was not sufficient to bring the *c. g.* of the load up to the datum plane. In the latter case the tires did not leave the landing

platform. The percentage rebound is the ratio, expressed in per cent, of the total rebound to the total drop. The maximum accelerations, expressed in terms of g , are the ratios of the maximum retarding forces to

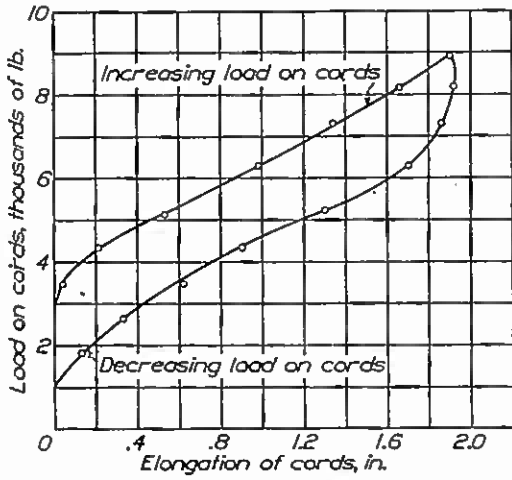

FIGURE 8.—Hysteresis curve of rubber cords on Mercury-type gear. Work done on rubber cords, 12,100 in.-lb.; work returned by rubber cords, 8,460 in.-lb.; work absorbed by rubber cords, 3,640 in.-lb. or 30.1 per cent

the static load. The stroke of the oleo unit is the relative displacement of the oleo cylinder with respect to the oleo piston. The cylinder pressure is the maximum unit pressure recorded in the oleo cylinder during

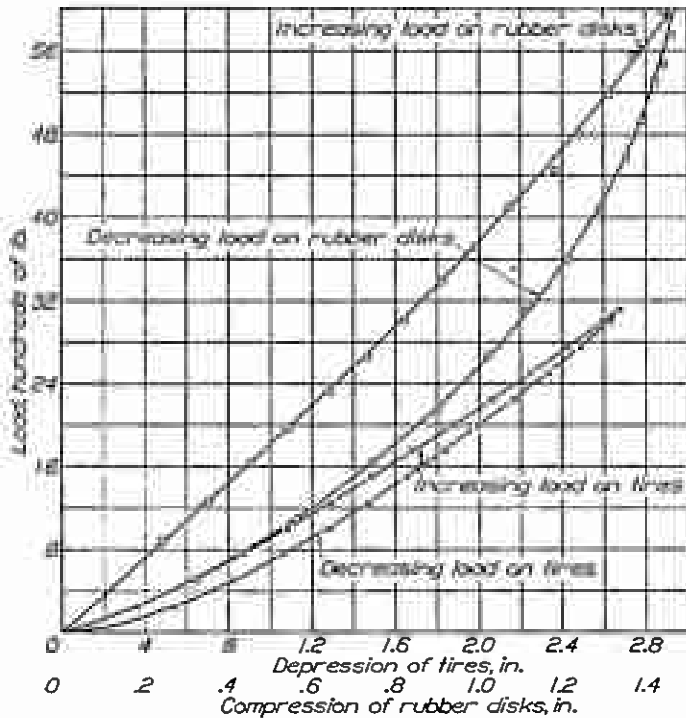

FIGURE 9.—Hysteresis curves of tires and rubber disks on NY-9 oleo gear. Work done on disks, 4,040 in.-lb.; work returned by disks, 2,840 in.-lb.; work absorbed by disks, 1,200 in.-lb. or 30.1 per cent. Work done on tires, 1,830 in.-lb.; work returned by tire, 1,625 in.-lb.; work absorbed by tire, 205 in.-lb. or 11.2 per cent

its initial contraction stroke. The cord elongation is the average elongation of the rubber cords as indicated by the relative displacement of the units on which they were wrapped.

Figure 10 shows the relations that exist between the free drop, the free rebound, and the total drop for the oleo and the Mercury landing gears. It will be noted that the free-rebound curve for the oleo gear is wholly negative, indicating that the tires of this landing gear did not leave the landing platform during drop tests.

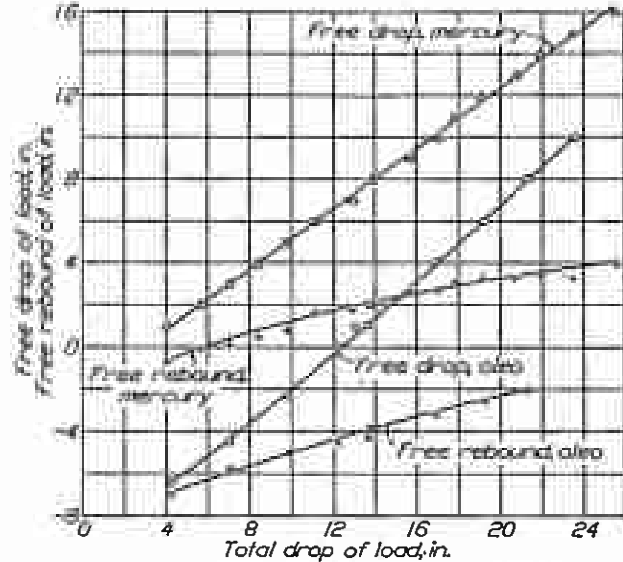

FIGURE 10.—Free drop and free rebound during drop tests

The total drops on the oleo gear greatly exceeded those on the Mercury gear for equal heights of free drop owing to the longer contraction stroke of the oleo shock-absorbing unit.

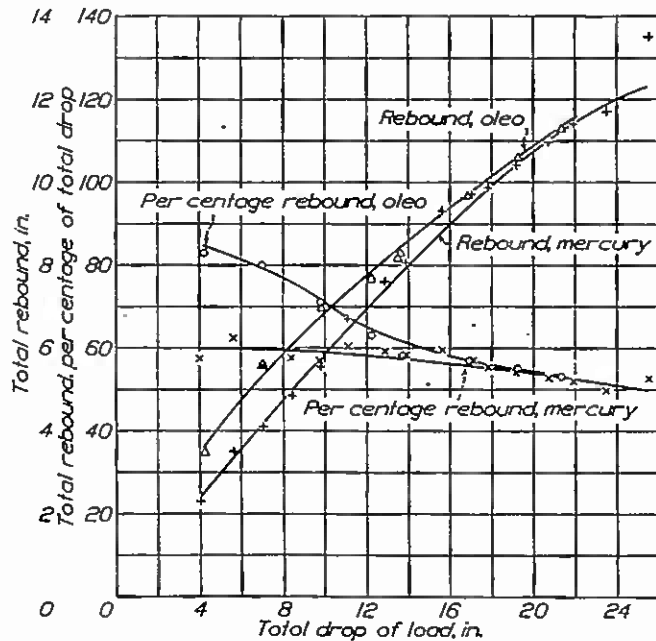

FIGURE 11.—Total rebound and percentage total rebound during drop tests

The curves of rebound and percentage rebound (fig. 11) indicate that the rebound was greater with the oleo gear than with the Mercury gear. This result appears contradictory to the curves of free rebound (fig. 10), but it must be remembered that the greater portion of the total drop with the Mercury gear was

an unrestrained drop; whereas with the oleo gear, the greater portion occurred with the tires in contact with the landing platform. Conversely, the rebound with the oleo gear occurred during the extension stroke of

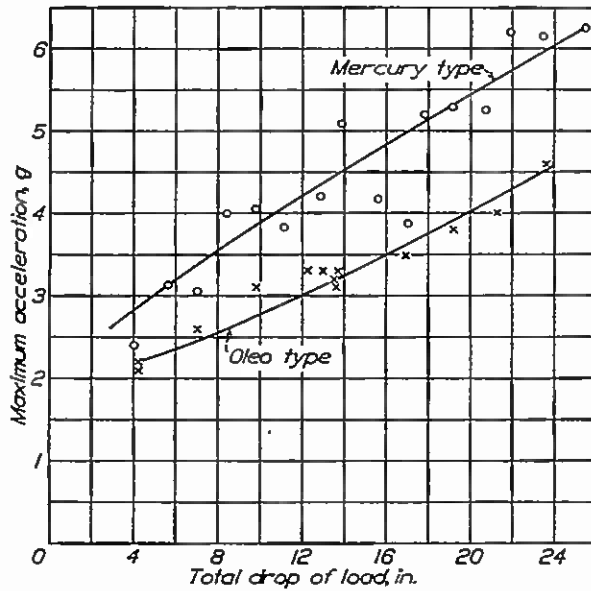

FIGURE 12.—Maximum accelerations developed in drop tests

the shock-absorbing unit; whereas only a small portion of the rebound with the Mercury gear occurred during the extension stroke of the shock-absorbing units. Since there were no rebounds causing complete extension of the shock-absorbing units of the

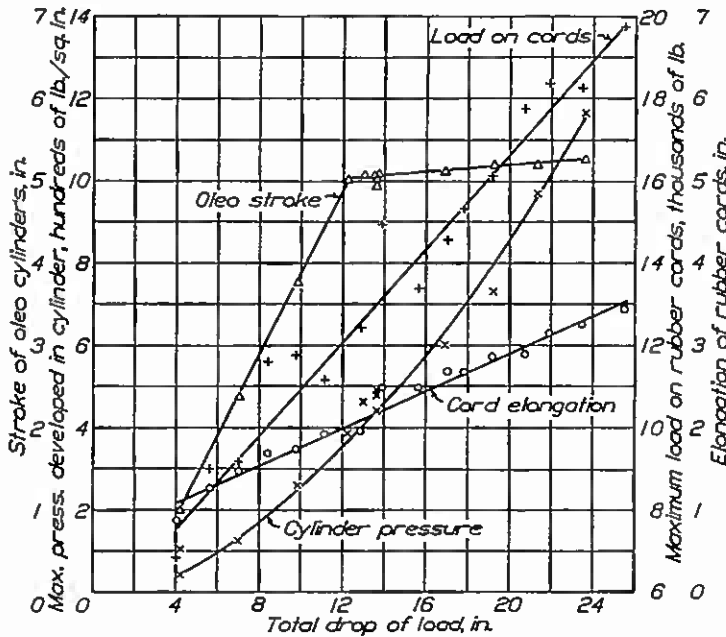

FIGURE 13.—Strokes of oleo cylinder, maximum pressure in cylinder, elongation of rubber cards, and load on rubber cards during drop tests

oleo gear the tires did not leave the landing platform; therefore there were no positive free rebounds in the drop tests on this landing gear. The rebounds on the Mercury gear were, however, large enough during some of the tests that the height attained by the tires

above the landing platforms represented as much as 25 per cent of the free drop. Thus, although the actual vertical displacement of the load during the rebounds was greater with the oleo gear, the fact that the tires did not leave the landing platforms would indicate that rebounds with this gear would be less hazardous than with the Mercury gear.

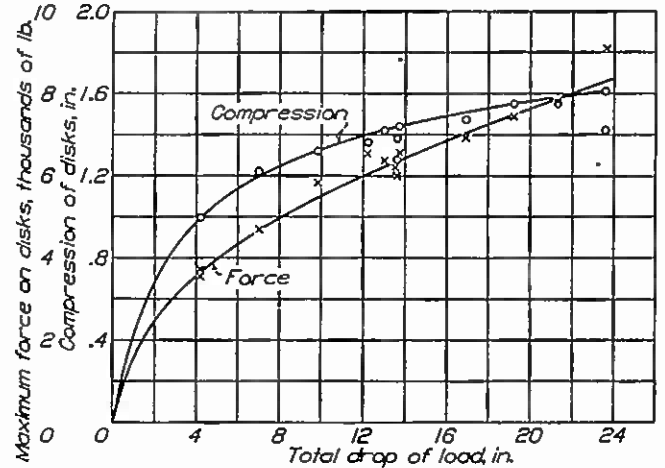

FIGURE 14.—Compression of rubber disks and forces on them during drop tests

Figure 12, curves of maximum accelerations against total drop of load, shows that the qualities of the oleo gear for minimizing impact forces were better than those of the Mercury gear.

Figures 13 and 14 show the relative maximum distortions and maximum loads on the shock-absorbing

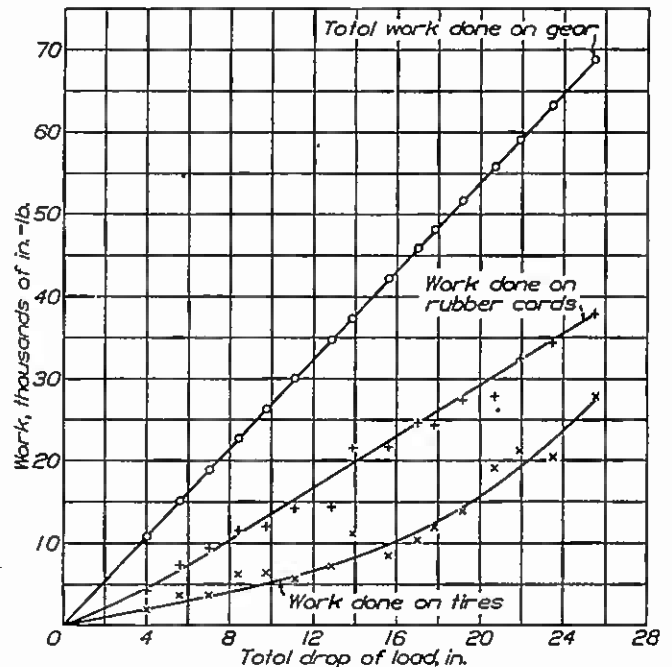

FIGURE 15.—Total work and distribution of work on Mercury-type landing gear

units of the two landing gears in the drop tests. The relative magnitudes of these values are not only dependent upon the impact-minimizing qualities of the landing gears but also upon the geometric relation of the members of the chassis.

Figures 15 and 16 are furnished primarily to show the distribution of work among the shock-absorbing units of the two landing gears. In this work-distribution treatment, it was not possible to account for all of the work done by the load in its initial drop

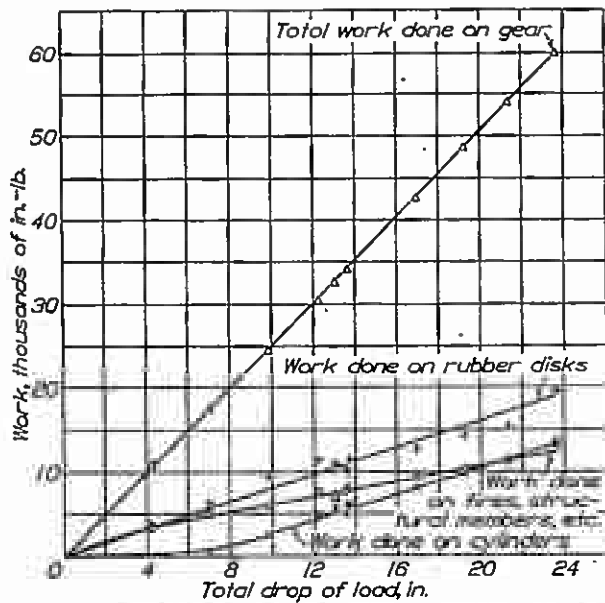

FIGURE 16.—Total work and distribution of work on oleo-type landing gear

as a portion of this work was taken by the bending of the axles and the distortions of the structural members of the landing gears and test rig. As no attempt was made to measure these distortions during the drop

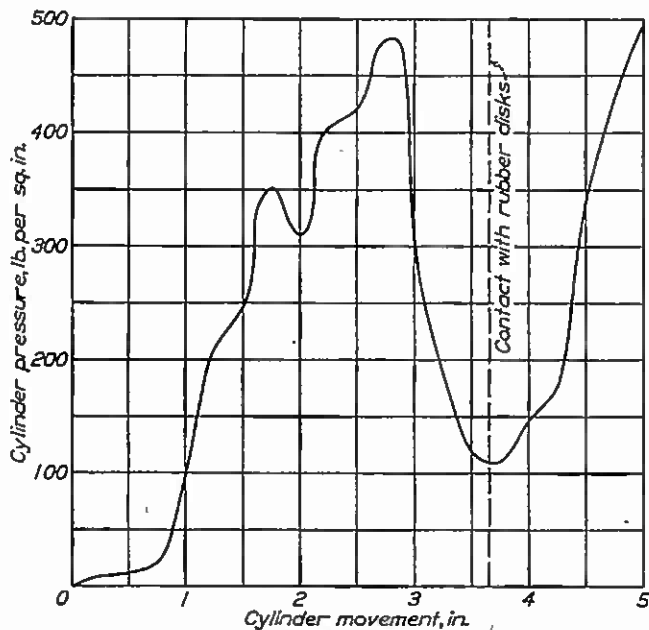

FIGURE 17.—Variation of cylinder pressure with cylinder displacement for an NY-3 oleo gear. Free drop of 1 inch. Oil level 4 3/8 inches from top of piston with full load on gear.

tests, the amounts of energy taken by them could not be computed.

The figures show that when the tires were used on the Mercury gear they took a larger percentage of the total work done by the load than when they were

used on the oleo gear. This fact indicates that with complete depression of the tires a smaller amount of work would be done on the Mercury gear than on the oleo gear. As complete depression of the tires is usually the limiting factor of the useful capacity of a landing gear, it appears that the useful capacity of the Mercury gear is considerably less than that of the oleo gear.

Figure 16 shows that the amount of energy absorbed by the hydraulic unit is less than that taken by the rubber disks. This condition, and the fact that the stroke of the hydraulic unit was considerably longer than the linear compression of the rubber disks, shows that the average retarding force offered by the hydraulic units was much smaller than that offered by the disks. In an efficient shock-absorbing system, the hydraulic unit should offer the larger retarding force and should also absorb the major portion of the

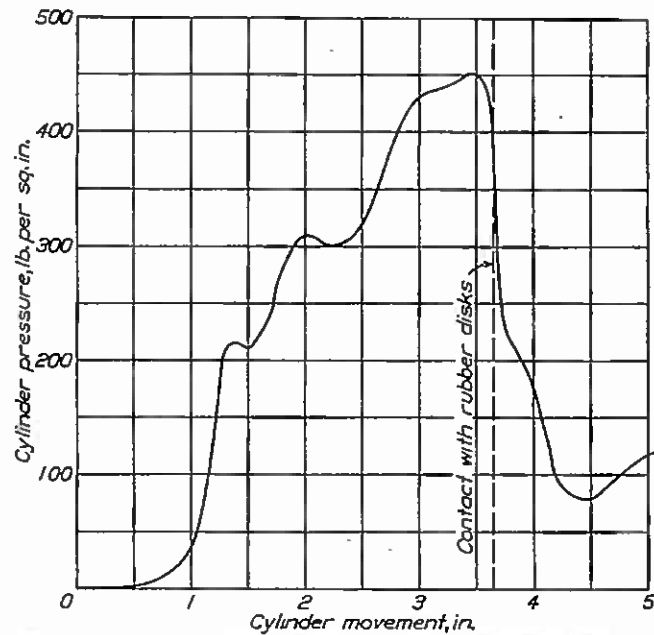

FIGURE 18.—Variation of cylinder pressure with cylinder displacement for an NY-8 oleo gear. Free drop of 1 inch. Oil level 5 3/8 inches from top of piston with full load on gear.

work done on the system, leaving the rubber disks to fulfill their function of reducing the taxiing loads. As the results show that the oleo gear does not approach this condition, it is evident that an improvement of the design of the hydraulic system should be made.

Figures 17 and 18 furnish histories of the pressures in the oleo cylinders obtained from a 1-inch free drop with the oleo landing gear. Figure 17 shows the pressure history when the cylinder was charged with oil to the level indicated by the oil gage furnished with the unit, and Figure 18 shows the pressures, under the same test conditions, with cylinder charged with oil to a level approximately 1 inch below that recommended. It will be seen that when the oleo unit is charged with too much oil, the pressure at the end of the stroke becomes excessive.

Flight tests.—The results of the flight tests are presented in Tables I, II, and III and in Figures 19 to 25.

The results presented in the tables and Figure 19, with the exception of the wind speed and the maximum acceleration subsequent to contact, are results obtained during the initial stroke of the shock absorber of the airplane. The wind speed is the average taken over a short period of time (usually one minute) immediately preceding and succeeding the landing of

in the maximum impact forces from $3\frac{1}{4}$ to 5 times the static load. In these landings the oleo gear was superior to the other gears in reducing the maximum impact forces. The curves indicate that for vertical velocities of 8 feet per second at contact the maximum accelerations developed with the different landing gears are approximately $3\frac{1}{4}$, $4\frac{1}{2}$, and 5 times the static load with the oleo, rubber-cord, and Mercury landing gears, respectively.

Tables I, II, and III show that the effectiveness of the three landing gears to reduce impact forces during the ground runs was approximately the same. The results also show that, in general, the maximum accelerations developed in good landings (1.8g, 2.35g, and 2.1g) were less than those developed in the ground runs (2.65g, 2.95g, and 2.75g) with the oleo, Mercury, and rubber-cord gears, respectively. These results indicate that the unevenness of the landing field governs, to a large degree, the maximum forces encountered in good landings.

In the pancake-landing tests all but three of the landings were made by gliding onto the ground without leveling off. The three pancake land-

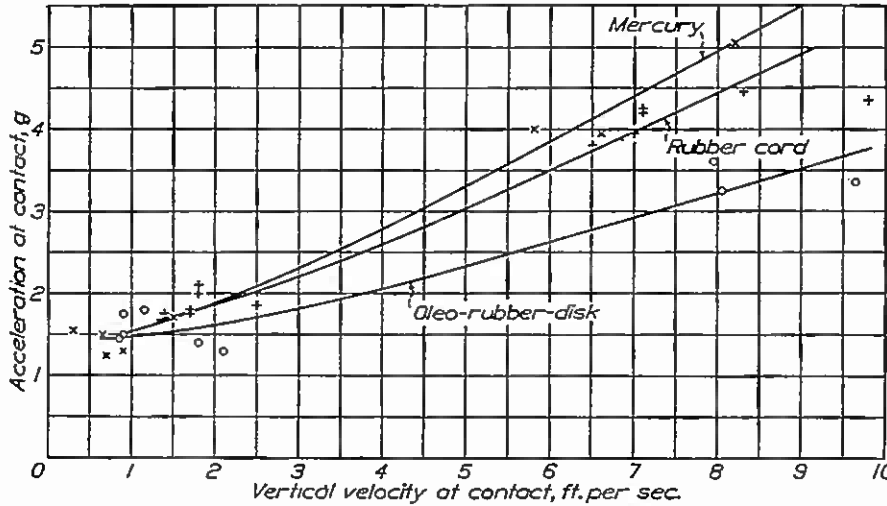

FIGURE 19.—Comparison of flight tests results of NY-2 landing gears

the airplane. The maximum accelerations subsequent to contact are the maximum accelerations experienced in the ground runs.

The results presented in Figures 20 to 25, inclusive, are histories of some of the landings taken for approximately the last 10 feet of vertical descent of the airplane prior to making contact. These results provide a means of directly comparing the effectiveness of the three landing gears. This effectiveness is based upon the maximum accelerations developed at contact (ability to minimize landing forces) and the observed bouncing tendencies of the gears (ability to dissipate the energy taken in minimizing the landing shocks). By making the comparison of the effectiveness of the landing gears on the basis of maximum accelerations at the *c. g.* of the airplane, the attitude of the airplane at contact does not enter into the consideration.

Figure 19 shows the comparison of the maximum accelerations developed with the different landing gears for various vertical velocities of the airplane at contact. The visually good landings (normal and 2-point) had vertical velocities at contact of less than $2\frac{1}{2}$ feet per second. In these landings the effectiveness of the various landing gears was approximately the same; the maximum impact forces varied from $1\frac{1}{4}$ to $2\frac{1}{4}$ times the static load. For the visually bad or pancake landings, the vertical velocities varied from approximately $5\frac{1}{2}$ to 10 feet per second with a variance

ings made by leveling off at approximately 5 feet above the ground and allowing the airplane to "drop in" from that altitude were made on the rubber-cord gear and are indicated in Table III by index a. It will be noted

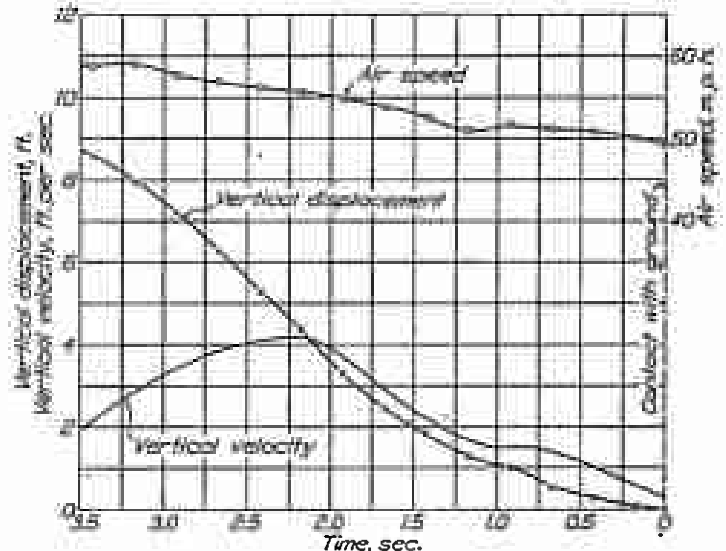

FIGURE 20.—Normal landing

that the severity of the glide landings and that of the "dropped-in" landings were approximately the same.

In most of the pancake landings the attitude of the airplane was such that at the instant of contact of the

tires with the ground the tail of the airplane was less than 1 foot above the ground.

No attempt was made to measure the rebound of the airplane during the flight tests but visual observations enable a very general comparison to be made of the energy-dissipating qualities of the shock-absorbing units. In most of the landings made with the oleo gear, there was very little rebound, but with the Mercury and rubber-cord gears it was practically impossible to make any type of landing without an appreciable rebound. In the severe pancake landings with the two latter gears the rebounds became so violent that it was considered unsafe to make landings of greater severity.

The pilots preferred the oleo gear because it "felt smooth" in landing, while the other two made the landings feel "stiff" and "snappy."

Figures 20 to 25, inclusive, show representative histories of the vertical displacement, vertical velocities, and air speeds of the airplane for the various types of landing tests made. The landings from which these histories were made are indicated in the tables by index h. It will be noted from the vertical-displacement histories that the flight paths of the airplane in the normal and 2-point landings were very similar. These histories also show

pancake landing is shown in Figure 25. It will be noticed that the vertical velocity at contact for the "glide" landing was less than that for the "dropped-in" landing.

Comparison of drop and flight tests.—Inasmuch as

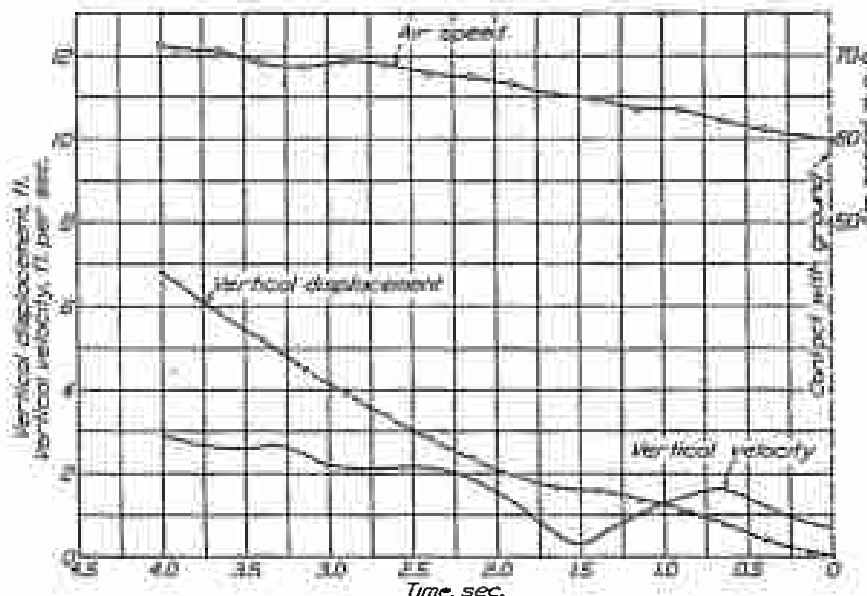

FIGURE 22.—Two-point landing

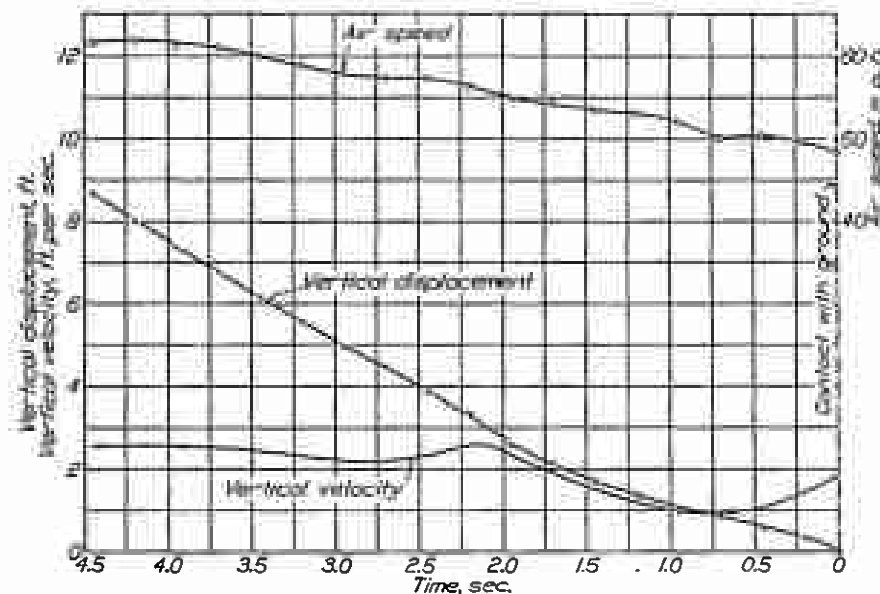

FIGURE 21.—Normal landing

that in landings of these types there is a tendency of the airplane to "drop in" just prior to contact.

The vertical-velocity history of a pancake landing in which the airplane was "dropped in" a short distance is shown in Figure 24. The history of a "glide"

test requirements for landing gears are specified upon a basis of free drops, it is interesting to compare the results of the flight and drop tests. In the most severe landings experienced in the flight tests (those in which the vertical velocities at contact were 7.95 and 8.2 feet per second) maximum accelerations of 3.6g and 5.05g were developed with the oleo and the Mercury gears, respectively. If it be assumed that the energy received by the landing gears varied as the square of the vertical velocity at contact, the ratio of the energies received by the oleo and the Mercury landing gears was 1 to 1.06. The drop-test results indicate that maximum accelerations of the above magnitude would be realized with total drops of 16.8 inches and 17.4 inches or free drops of 3.8 inches and 10.4 inches with the oleo and the Mercury landing gears, respectively. The ratios of such heights of drop are 1 to 1.03 for the total drops and 1 to 2.74 for the free drops. Thus, it is evident that if the results of the drop tests are used to predict the

action of the landing gears under flight conditions with respect to their impact force-reducing qualities, the results on the basis of total heights of drop would approximate those of the flight tests, while the results on a basis of free drop would give very erroneous results.

CONCLUSIONS

1. The oleo gear is the most effective of the three landing gears tested in minimizing impact forces and in dissipating the energy taken in so doing.

2. The flight-test results indicate that in pancake landings with a contact vertical velocity of 8 feet

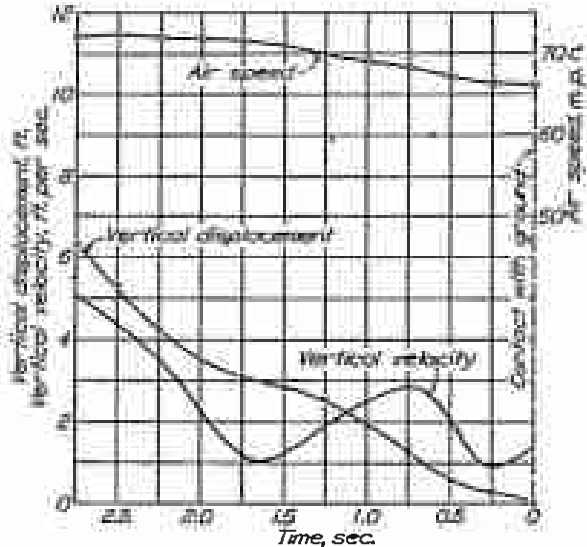

FIGURE 23.—Two-point landing

per second the maximum accelerations experienced are approximately 3.2*g*, 4.9*g*, and 4.4*g* with the oleo,

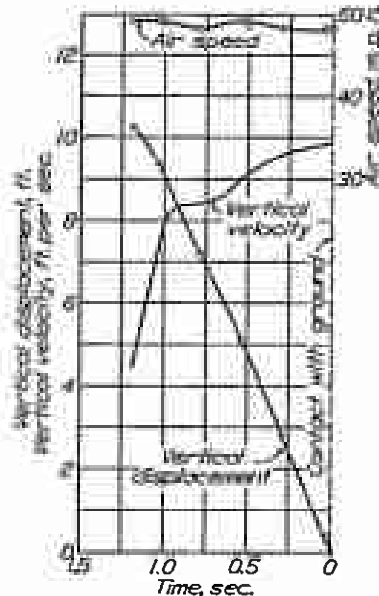

FIGURE 24.—Pancake landing

the Mercury, and the split-axle rubber-cord gears, respectively.

3. The rebounds, or bounces, in the severe landings with the Mercury and the rubber-cord landing gears were very violent and at times put the airplane in a very dangerous attitude.

4. The maximum accelerations at contact in the good landings were, in general, less than 2*g* and were of approximately the same magnitude with the three landing gears.

5. The maximum accelerations realized in the ground runs were, in general, less than 2.8*g* and were essentially of the same magnitude for the three gears.

6. The vertical velocities at contact were from 0.3 to 1.8 feet per second, 0.9 to 2.5 feet per second, and

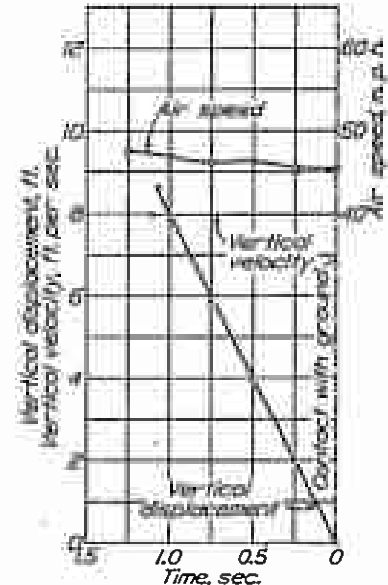

FIGURE 25.—Pancake landing

5.8 to 9.8 feet per second for the normal, 2-point, and pancake landings, respectively.

7. Results of drop tests should be compared upon a basis of total drop of load rather than upon one of equal free drop.

LANGLEY MEMORIAL AERONAUTICAL LABORATORY,
NATIONAL ADVISORY COMMITTEE FOR AERONAUTICS,
Langley Field, Va., August 7, 1931.

REFERENCES

1. Peck, W. C.: Dynamic and Flight Tests on Rubber-Cord and Oleo-Rubber-Disk Landing Gears for an F6C-4 Airplane. T. R. No. 366, N. A. C. A., 1930.
2. Peck, W. C., and Beard, A. P.: Static, Drop, and Flight Tests on Musselman-Type Airwheels. T. R. No. 381, N. A. C. A., 1931.
3. Norton, F. H.: N. A. C. A. Control-Position Recorder. T. N. No. 97, N. A. C. A., 1922.
4. Norton, F. H.: N. A. C. A. Air-Speed Meter. T. N. No. 64, N. A. C. A., 1921.
5. Reid, H. J. E.: The N. A. C. A. Three-Component Accelerometer. T. N. No. 112, N. A. C. A., 1922.
6. Brown, W. G.: The Synchronization of N. A. C. A. Flight Records. T. N. No. 117, N. A. C. A., 1922.

TABLE I.—RESULTS OF FLIGHT TESTS ON NY-2 OLEO GEAR MOUNTED ON NY-2 AIRPLANE, WEIGHT 2,730 POUNDS

Type of landing	Speed (m. p. h.)			Vertical velocity at contact (ft./sec.)	Acceleration (g)		Remarks
	Air	Wind	Ground		At contact	Subsequent to contact	
Normal.....	45	--3	48	0.9	1.75	2.10	Normal landings made with wind. Do. Do.
Do.....	45	-2	47	.85	1.45	2.65	
Do.....	47	-3	50	1.15	1.8	2.45	
2-point.....	59	6	53	1.8	1.4	2.15	Rather severe glide landing. Ordinary pancake. Glider in from about 15 feet.
Do.....	55	7	48	2.1	1.3	1.9	
Do.....	54	6	48	.9	1.5	1.95	
Pancake.....	46	6	39	0.65	3.35	2.95	
Do.....	46	7	39	3.05	3.25	1.95	
Do.....	48	8	38	7.95	3.6	2.15	
Taxi-run.....						1.8	
Do.....						1.7	
Take-off.....	63	9	54			2.3	
Do.....	69	9	50			2.35	

^b Landing used in history plotted in Figure 25.

TABLE II.—RESULTS OF FLIGHT TESTS ON NY-2 MERCURY LANDING GEAR MOUNTED ON NY-2 AIRPLANE WEIGHT 2,715 POUNDS

Type of landing	Speed (m. p. h.)			Vertical velocity at contact (ft./sec.)	Acceleration (g)		Remarks
	Air	Wind	Ground		At contact	Subsequent to contact	
Normal ^b	49	7	42	0.8	1.55	1.7	Tail slightly off ground. "Perfect" 3-point landing. Good landing.
Do.....	47	6	41	.9	1.3	1.9	
Do.....	45	7	39		1.45	2.15	
2-point.....	61	8	53	1.5	1.7	2.45	Attitude of airplane changed very little. Do. Glider from about 12 feet. Wheels slightly first. Very little bounce.
Do.....	60	7	53	.7	1.25	2.9	
Do.....	62	6	56		1.5	2.3	
Pancake.....	45	9	35	6.6	3.95		Smooth pancake. Very severe. Glider from about 15 feet. Rather fast taxi-run.
Do.....	45	11	35	5.8	4.0		
Do.....	42	10	32	3.2	5.05		
Taxi-run.....						1.85	
Do.....						2.0	
Take-off.....	48	12	36			2.1	Comparatively smooth. Fairly rough.
Do.....	50	12	38			2.4	

^b Landings used in histories plotted in Figures 20 and 22.

TABLE III.—RESULTS OF FLIGHT TESTS ON NY-2 RUBBER-CORD LANDING GEAR MOUNTED ON NY-2 AIRPLANE, WEIGHT 2,700 POUNDS

Type of landing	Speed (m. p. h.)			Vertical velocity at contact (ft./sec.)	Acceleration (g)		Remarks
	Air	Wind	Ground		At contact	Subsequent to contact	
Normal.....	50	8	42	1.7	1.75	2.4	Tail low 2-point; bounced considerably but not violently; wind steady. Excellent 3-point; no bounce. Slightly tail high, smooth landing, very little bounce; wind steady.
Do.....	45	10	36	1.7	1.8	1.95	
Do.....	43	8	40	1.8	2.0	2.3	
2-point.....	62	6	56	2.5	1.95	2.1	Tail somewhat low. Seemed to float in with tail low. Tail well up.
Do.....	59	6	53	1.8	2.1	2.05	
Do.....	56	7	59	1.4	1.75	1.85	
Pancake ^a	48	10	33	7.1	4.2	2.3	Floated to within 5 feet of ground and dropped abruptly, fairly severe; bounced about 1 foot. Fairly severe, no sharp change in vertical velocity; bounced about 1 foot. Very pronounced drop from about 4 feet; bounced about 1 foot.
Do.....	44	9	35	8.8	4.45	2.05	
Do.....	40	7	33	7.0	3.55	2.2	
Do.....	48	10	36	9.8	4.35	4.1	Glider in from about 30 feet, wheels first; bounced about 2 feet, bucked. Wheels first, fairly mild; bounced about 1 foot, bucked. Wheels first, quite violent, bucked; bounced 2 feet or more.
Do.....	46	12	34	6.5	3.8	2.75	
Do.....	48	7	41	7.1	4.25	3.2	
Taxi-run.....						1.85	Fairly rough run. Representative run.
Do.....						1.75	
Take-off.....	45	9	36			1.9	Smooth take-off. Airplane started bucking and had to be pulled off ground.
Do.....	40	9	31			2.75	

^a"Drop-in" landings from about 5 feet altitude.

^b Landings used in histories plotted in Figures 21, 23, and 24.