

UNCLASSIFIED

AD NUMBER	
AD071692	
CLASSIFICATION CHANGES	
TO:	unclassified
FROM:	restricted
LIMITATION CHANGES	
TO:	Approved for public release, distribution unlimited
FROM:	Distribution authorized to DoD only; Foreign Government Information; MAY 1955. Other requests shall be referred to British Embassy, 3100 Massachusetts Avenue, NW, Washington, DC 20008.
AUTHORITY	
DSTL, AVIA 6/19483, 31 Jul 2008; DSTL, AVIA 6/19483, 31 Jul 2008	

THIS PAGE IS UNCLASSIFIED

UNCLASSIFIED

TECH. NOTE
ARM.566

Decl OADR (may 55)R

TECH. NOTE
ARM.566



U.S.

~~CONFIDENTIAL~~

Per Auth. Da Circular
#127, 23 Dec 53
~~RESTRICTED~~



ROYAL AIRCRAFT ESTABLISHMENT

FARNBOROUGH, HANTS



TECHNICAL NOTE No: ARM.566

REVIEWED ON:

11-21-85 R. W. Foman
Date Signature

THE DEVELOPMENT AND TRIALS OF A MODIFIED 500 lb M.C. BOMB FITTED WITH A NEW FIXED FIN TAIL

by

M.O.HOOK, B.Sc., A.F.R.Ae.S.

OIN 11017

MAY, 1955



1. THIS INFORMATION IS DISCLOSED FOR OFFICIAL USE BY THE RECIPIENT GOVERNMENT. DISCLOSURE TO ANY OTHER GOVERNMENT OR RELEASE TO THE PRESS OR IN ANY OTHER WAY WOULD BE A BREACH OF THIS CONDITION.
2. THE INFORMATION SHOULD BE SAFEGUARDED UNDER RULES DESIGNED TO GIVE THE SAME STANDARD OF SECURITY AS THAT MAINTAINED BY HER MAJESTY'S GOVERNMENT IN THE UNITED KINGDOM.
3. THE INFORMATION CONTAINED IN THIS DOCUMENT SHOULD NOT BE CIRCULATED OUTSIDE GOVERNMENT DEPARTMENTS WITHOUT THE PRIOR PERMISSION OF THE MINISTRY OF SUPPLY.
4. THE RECIPIENT IS WARNED THAT INFORMATION CONTAINED IN THIS DOCUMENT MAY BE SUBJECT TO PRIVATELY OWNED RIGHTS.

PICATINNY ARSENAL

TECHNICAL INFORMATION SECTION

MINISTRY OF SUPPLY

INV 90

THIS DOCUMENT IS THE PROPERTY OF H.M. GOVERNMENT AND ATTENTION IS CALLED TO THE PENALTIES ATTACHING TO ANY INFRINGEMENT OF THE OFFICIAL SECRETS ACT, 1911-1939.

It is intended for the use of the recipient only, and for communication to such officers under him as may require to be acquainted with its contents in the course of their duties. The officers exercising this power of communication are responsible that such information is imparted with due caution and reserve. Any person other than the authorised holder, upon obtaining possession of this document, by finding or otherwise, should forward it, together with his name and address, in a closed envelope to:-

THE SECRETARY, MINISTRY OF SUPPLY, LONDON, W.C.2

Letter postage need not be prepaid, other postage will be refunded. All persons are hereby warned that the unauthorised retention or destruction of this document is an offence against the Official Secrets Act

Free #1
13-43
988886

Best Available Copy

~~RESTRICTED~~

~~CONFIDENTIAL~~

Per Auth. Da Circular
#127, 23 Dec 53

20080207324

~~RESTRICTED~~

UNCLASSIFIED

U.D.C. No. 623.451.746.1

Technical Note No. Arm 566

May, 1955

ROYAL AIRCRAFT ESTABLISHMENT, FARNBOROUGH

The development and trials of a modified 500 lb M.C. bomb fitted with a new fixed fin tail

by

M.O. Hook, B.Sc, A.F.R.Ae.S.

RAE Ref: Arm 3506/3/A

SUMMARY

A Naval requirement exists for the use of 500 lb M.C. bombs on the new higher speed fighter-bombers now coming into Service. To meet this requirement existing World War II bombs have been modified and a new fixed fin tail has been designed for use with these modified bombs. The modified bombs and new tail are described in this note, which also gives details of the development trials which have been carried out. Recommendations for additional trials are given.

UNCLASSIFIED

AD-071692

LIST OF CONTENTS

	<u>Page</u>
1 Introduction	3
2 Description of bomb and tail	3
2.1 Bomb	3
2.2 Tail	3
3 Development trials	4
3.1 Tail strength	4
3.2 Stability trials	4
3.3 Trials of Naval Safety Catch	5
3.4 Tail endurance trials	6
3.5 General functioning trials	7
4 Further work	8
5 Conclusions	8
6 Recommendations	8
References	9
Advance Distribution	9
Detachable Abstract Cards	

LIST OF APPENDICES

	<u>Appendix</u>
Description of Bomb Tail No. 112 (Experimental Type XT1)	I
Strength Test of Tail	II
Physical Data: Calculation of Time Period Factor	III
Stability Trial: Analysis of Film	IV
Tests of Naval Safety Catch	V
Functioning Trial Results	VI

LIST OF ILLUSTRATIONS

	<u>Fig.</u>
500 lb M.C. Bomb with Tail Type XT1	1(a)
500 lb M.C. Bomb Mk.18 showing Aft end and Lifting Plate	1(b)
General view of Tail (XT1) showing Arming Vane and Fairing detached	2(a)
Interior view of Tail (XT1) showing Arming Mechanism and Bolts	2(b)
Diagram of Arming Release Mechanism (Tail No. 112)	3
Strength Test on Bomb Tail (XT1)	4
Load Distribution for Strength Test	5
Bomb Oscillation Curves (Stability Trial)	6(a)-(f)
Typical Views of Bomb (500lb M.C.) Oscillating in Flight	7
Naval Safety Catch - Plot of Release Torque Setting against Maximum Speed	8

1 Introduction

1.1 A Naval requirement exists for the use of 500 lb M.C. bombs on new Naval fighter bomber aircraft. To meet this requirement it had been decided to use existing World War II bombs modified to allow external carriage on wing pylons fitted with the new type release units.

1.2 The tails originally provided for these existing bombs were of the cone and drum type. It was considered that this type of tail was unsuitable for use with bombs carried externally on, and released at high speed from the new naval ground attack aircraft such as the Sea Hawk. The reasons were:-

- (a) drag would probably be excessive;
- (b) stability was doubtful;
- (c) attachment of tail to bomb was known to be unsatisfactory.

Since low drag is important for the higher speed aircraft now coming into Naval Service and since the tail loading conditions will be severe, a new fixed radial fin tail has been developed for use with the modified 500 lb M.C. bombs.

1.3 The modified bombs and new tail are described in this note. Details are given of development trials which have been carried out. Recommendations for additional trials are also included.

2 Description of bomb and tail

2.1 Bomb

Four marks of bomb were suitable for conversion for Naval use, i.e. Mks.7,8,10 and 14. These different marks of bomb vary from one another mainly in the method of construction, i.e. forged, cast or fabricated by welding. There is a nominal variation of $\frac{1}{2}$ " in outside diameter and a difference in the form of the nose, i.e. solid or plugged. The base end, to which the tail is attached is, however, the same for all marks. To make them suitable for carriage on pylons, the existing welded-on suspension lugs were removed and an external lug housing (Housing, Lug, Suspension No. 1 Mk.1) as used on the 1000 lb M.C. Mk.6¹ and Mk.9 bombs, was fitted. This takes the No. 27 suspension lug and the combination is suitable for use either with external pylon stowage or for internal stowage with the new No. 1 release unit, if this is ever required. If it is desired to use these modified bombs on aircraft fitted with the old Type N release units, the No. 27 lug is replaced by the No. 29 lug. The modified bombs become the Mks.18 to 22 inclusive. Figs.1(a) and 1(b) give views of the Mk.18 bomb.

2.2 Tail

The new design of tail consists of two main parts, the tail proper (No. 112) which is bolted to the end of the bomb and a fairing (No. 30). The latter is attached to the base ring of the tail and bridges the gap between the end of the tail proper and the bomb to give a clean aerodynamic shape. A detailed description of the experimental tail (Type XT1) used in the development trials is given in Appendix I; the experimental tail differs from the production tail (No. 112) only in minor respects. The experimental fairing used in the trials differed from the production version in that no positive adjustment to suit varying bomb diameters was provided. Experience in the trials showed that without this positive adjustment,

slackness between the bomb and fairing could occur. The production fairing incorporates a screw adjustment which ensures a tight fit between the fairing and bomb; in this way expected variations in diameter are accommodated. Views of the experimental tail and fairing are shown in Figs.1(a), 2(a) and 2(b). The arming gear fitted to this tail, which includes a Naval Safety Catch, is similar to that fitted to the 1000 lb M.C. bomb tail No. 107¹ many of the details being common. A diagram of the Release Mechanism is given in Fig.3.

3 Development trials

3.1 Tail strength

Two versions of the experimental tail were tested, the first having a plain cone and the second having longitudinal stiffening swages formed in the cone. The first version failed by buckling of the cone at less than the specified ultimate load. The second, with stiffening swages, satisfactorily met the specified ultimate load. Full details of this test and the results obtained are given in Appendix II. The loads² applied were based on the conditions applying when the bomb is released at 550 knots in air at standard sea level density, an initial pitch on release of 30° incidence being assumed. Fig.4 shows the bomb and tail in the test rig during this test, and a loading diagram is given in Fig.5.

3.2 Stability trials (R.A.E. Trial Ref. BD/16/54)

3.21 Stability trials were carried out to determine the non-dimensional factors for the bomb with this tail, using the Low Altitude Technique³. A large initial disturbance was artificially imparted to each store by the clip and wire method. Six Mk.18 bombs with Type XT1 tails were released singly from a Lincoln aircraft flying at 169 knots T.A.S. and at altitude of about 1500 ft. The flight of each store was recorded from the ground by means of a high speed cine camera situated about 500 yards horizontally from the line of flight of the aircraft. The camera speed was 64 exposures per second.

3.22 Physical constants

Preliminary laboratory readings were taken, before the trial, to determine the dimensions, weight, centre of gravity position and moment of inertia (about a diameter through the centre of gravity and normal to the axis) for each complete store. The results of these readings are tabulated in Appendix III.

3.23 Results

It has been shown⁴ that the Time Period Factor can be calculated from the physical constants. Calculations for these six bombs, using formulae previously derived^{2,4}, are given in Appendix III.

The graphical analysis of the films, showing angular oscillations against time is given in Fig.6(a)-(f). Detailed calculations of the Non Dimensional Stability Factors, i.e. Time Period Factor and Damping Factor, from the experimental data are given in Appendix IV.

These results are summarised in the table below:-

/Table

Ref. No.	Weight of Store lb.	C.G. Distance from Nose ft.	Moment of Inertia - lb/ft ²	Stability Factors		
				Damping	Time Period	
					Exptl.	Theortl.
Criterion	-	-	-	Not less than 6.0	Not more than 2.5	
1	482	2.13	553	15.2	1.44	1.34
2	488	2.15	579	12.7	1.32	1.34
3	476	2.13	555	9.75	1.50	1.36
4	487	2.15	632	11.7	1.37	1.46
5	482	2.17	612	11.6	1.42	1.43
6	490	2.17	622	10.8	1.48	1.45
Mean	484.2	2.15	592	12.0	1.42	1.40
Standard Deviation	4.7	0.017	31.5	1.71	0.062	0.053

3.24 Discussion of results

Reference to this table shows that the readings of weight and centre of gravity are quite consistent among the six bombs used for this trial. There is, however, appreciable scatter in the moment of inertia readings.

It is to be noted that, owing to the prevailing conditions some difficulty was experienced in keeping the camera on the bomb during its fall. Consequently the plotting of the oscillation curves (Figs.6(a)-(f)) is not quite continuous; the missing parts have been interpolated from the general trends of the curves and are shown by broken lines in Figs.6(a) to (f).

In spite of these factors, the Time Period Factor readings, both experimental and theoretical are remarkably consistent, the greatest deviation from the mean being about 7%. There is also close agreement between the experimental and theoretical values. All the time period readings are well within the permissible maximum⁴.

A considerable scatter will be noted in the Damping Factor values. This is partly due to the fact that the logarithmic factor is very sensitive to small variations in the amplitude readings (see Appendix IV). The values are, however, all well above the required minimum⁴.

Visual observation of the bombs showed that they were very stable. The pitching had virtually disappeared after four or five oscillations. This is well shown by the still pictures, in Fig.7, which are taken from the film of store No.4. The views are at approximately quarter period intervals showing the bomb in its extreme and mean attitudes starting immediately on release.

3.3 Trials of Naval Safety Catch (R.A.E. Trial Ref. BD/15/54)

3.31 Description

The Naval Safety Catch forms part of the arming gear of the tail. It is very similar to the mechanism in the Tail No. 107 for 1000 lb M.C. bombs

which is described elsewhere⁵. The particular safety catch fitted to the tails tested in this trial is described in Appendix I and illustrated in Figs. 2(b) and 3. Its function is to ensure that arming cannot take place below a forward speed of 140 knots while not preventing arming at speeds of 170 knots and above. This safety feature is incorporated to ensure that when an aircraft lands on a carrier deck, with bombs on, the bombs will not become armed if accidentally released with the fuze gear in the 'fuzed' position.

3.32 Flight tests

Flight tests were carried out to determine the range of torque setting required to ensure that the Naval Safety Catch operated correctly in the specified speed range. Nine flights were made with the bombs and tails carried on the pylons of a Venom aircraft; six different tails with various torque settings were used. The method of test and tabulated results are given in Appendix V and a plot of torque setting against maximum speed in Fig. 8. The two lines AA and BB in Fig. 8 demarcate three zones which have the following significance:-

- (a) Co-ordinates in the zone above AA show the torque/speed combination which would be expected to prevent any operation of the arming gear.
- (b) Co-ordinates in the zone below BB show torque/speed combinations which would be expected to allow operation of the arming gear.
- (c) The zone between AA and BB is a region where the effect of any torque/speed combination lying in that zone would be unpredictable.

From Fig. 8 it appears that the required torque setting for the Tail No. 112 lies between $7\frac{1}{4}$ lb in. and 9 lb in. These settings have therefore been adopted as the minimum and maximum settings for production tails.

3.4 Tail endurance trial (R.A.E. Trial Ref. BD/18/54)

3.41 Purpose of trial

Under conditions of high speed flight with external pylon stowage, bombs and tails are subjected to considerable vibration and buffeting. Failure of tails and tail fastenings have occurred in the past under these conditions. To investigate the endurance of the new tail it was considered necessary to carry out extended flight trials at high speed. It was desired in particular to check that (a) there was no loosening of the tail attachment to the bomb, (b) the arming vane attachment and arming gear were not adversely affected, and (c) there was no sign of failure in the structure of the tail, such as cracking of the shell etc.

3.42 Method of test

Two Mk. 18 bombs, with Type XT1 tails were mounted on the pylons of a Venom aircraft. One tail had longitudinal stiffening swages incorporated in the cone; the other had no stiffening swages. The fuze wires were connected in the usual way with the fuze units set to the 'safe' position. The aircraft made several flights in this condition, the total flying time being 6 hours 10 minutes. The maximum speed attained was 440 knots, this being the maximum speed limitation in force for the aircraft used at the time of the trial.

3.43 Details of flights

It was planned to start the trial with flights of comparatively short duration and low speed. If there were no sign of any damage or loosening of the tail, both duration and speed of flight were to be increased by steps.

Details of the flights are given below:-

<u>Flt. No.</u>	<u>Duration (Minutes)</u>	<u>Max. Speed (knots)</u>
1	30	300
2	40	350
3	40	300
4	70	420
5	90	440
6	100	440

The trial was interrupted by poor weather conditions during flight No.3; for this reason the duration and speed of this flight were limited. A maximum height of 23,000 ft, where the ambient temperature was -20°C , was reached on flights 4, 5 and 6.

3.44 Results of trial

The tails were critically examined after each flight and at the end of the trial, and no sign of damage or incipient failure could be found. There was no loosening of attachments. It can be concluded therefore that the Tail No. 112 is suitable for external carriage on high speed aircraft in prolonged flights, at speeds up to at least 440 knots. Further trials at the higher speeds possible with the Sea Hawk aircraft should be carried out when this aircraft is available.

3.5 General functioning trials (R.A.E. Trial Ref. BD/17/54)

3.51 Limited flight dropping trials of 500 lb Mk.18 bombs fitted with Type XT1 experimental tail units were carried out at B.T.U. West Freugh. Use was made of the Luce Bay sea target and Lincoln aircraft. The bombs were H.E. filled and fitted with No. 75 tail pistols and instantaneous detonators. The aims of these trials were:-

- (a) to check that bombs dropped 'live', would explode satisfactorily on impact;
- (b) to check that bombs could be dropped 'safe';
- (c) to check visually the stability of the bombs under the dropping conditions.

3.52 Altogether twenty bombs were dropped singly from altitudes varying from 10,000 ft to 29,000 ft. Twelve were 'live' drops and eight were 'safe' drops. The detailed results of this trial are given in Appendix VI from which it will be seen that all functioned correctly except for one 'live' fuzed bomb which failed to explode. Examination of the aircraft after the single failure did not provide any evidence on the cause of the failure; the fuzing unit appeared to have functioned correctly. The stability of the store appeared to be good at all heights of release.

3.53 No dropping trials have been carried out under the conditions of release applicable to the Sea Hawk aircraft as no suitable aircraft was available at R.A.E. during the period of these trials. It is desirable that such trials be carried out up to the maximum speed of release of the Sea Hawk aircraft to check:-

- (a) that the bomb with the new tail can be satisfactorily released, without damage to the aircraft, at all speeds;

- (b) that these bombs and tails can be released, either 'live' or 'safe', at all speeds;
- (c) that recovery from initial pitch at release, and subsequent stability are satisfactory.

It is suggested that such trials be included in the armament clearance trials of the Sea Hawk aircraft now pending at A & AEE.

4 Further work

End point ballistic trials of this bomb and tail have been carried out at O.R.S. The results of these trials will be published separately. Apart from these ballistic trials, no further work is proposed at R.A.E.

5 Conclusions

The limited development trials carried out appear to show that the 500 lb M.C. bomb Mks. 18 to 22 fitted with the fixed-fin tail No. 112 will be satisfactory for Naval use. The trials show that:-

- (a) the strength of the tail is adequate for speeds of release up to 550 kts EAS in conditions of 30° incidence at release;
- (b) stability is satisfactory;
- (c) the bomb and tail can be carried externally on pylon stowages for extended periods at speeds up to at least 440 kts without damage or loosening of fastenings;
- (d) functioning of bombs, released from heights up to 29,000 ft, appears to be satisfactory in either the 'live' or 'safe' condition; there is no evidence to show whether the one failure in 12 live drops is attributed to faulty tail mechanism, fuze or bomb; the sample is too small to allow any conclusion to be drawn;
- (e) the setting for the Naval safety catch forming part of the arming gear, should be between 7 $\frac{3}{4}$ and 9 lb in. to ensure arming between 140 kts EAS and 170 kts EAS.

6 Recommendations

The A & AEE armament clearance of the Sea Hawk aircraft should include the following trials of the 500 lb M.C. Mks. 18 to 22, fitted with Tail No. 112 and Fairing No. 30:-

- (a) endurance trials up to maximum aircraft speed (see para 3.44),
- (b) further 'live' and 'safe' dropping trials (see para 3.53).

REFERENCES

<u>No.</u>	<u>Author</u>	<u>Title, etc.</u>
1	Ross, A.C.	Development and testing of a new range of 1000 lb H.E. aircraft bombs (H.A./H.S. series) RAE Tech Note No. Arm 524
2	Hook, M.O.	Stressing Conditions for Bomb Tails RAE Tech Memo No. Arm 1311
3	Bomb Ballistics Group, RAE	Low Altitude Technique for Measurement of Stability Factors of Bombs Tech Note No. Arm 349
4	Hills, R.	The Aerodynamics of Armaments: Part I: Stability of Bombs and Rockets RAE Tech Note No. Aero 2255
5	Hook, M.O. and Crane, J.F.W.	1000 lb M.C. Bomb Mk.6 with fixed fin tail Type R. Trials of Naval Safety Catch and Arming Fan Torque RAE Tech Memo No. Arm 1509

Attached:

Appendices I-VI
Sk Arm 47002,3 47059-61
Neg Nos. 120,003-120,006
Detachable abstract cards

Advance Distribution

D Arm RD (Air)
NA/D Arm RD (Air)
AD Arm RD 2
A & AEE - 2
Sec OB
TPA3/TIB - 60
RD Arm 4 - 2
RD Arm 6
Director, RAE
DDRAE(E)
Pats 1/RAE
Library
Head of Arm Dept
Head of Bomb Armt. Divn
ARL
Mr. A.C. Ross
Mr. Hook

APPENDIX I

Bomb Tail Type No. 112
(Experimental Type XT1 - 500 lb M.C.)

1 General description

This tail consists of a conical body with four radial fins. The taper of the cone is about 7° , the overall length of the tail is 38.1" and the diameter at the large or base end 11.8". The fins have a leading edge sweepback of 45° . They have a total span of 18.2" and a gross projected area of about 198 sq in. per pair.

2 Construction

2.1 The body and fins are made in four sheet steel (20 s.w.g.) pressings joined together by swaged seams in the cone and by spot welding at the fin edges. Eight swages or cannelures are provided along the slant length of the cone to stiffen it. These swages were not provided in the first few Type XT1 tails, but were introduced because on test the cone failed by buckling. The stiffening swages are clearly shown in Figs.1(a) and 4. Fig.2(a) shows a tail without swages.

2.2 The cone has a cast aluminium alloy base ring to which it is riveted and by which the tail is attached to the bomb.

2.3 The fins have internal stiffeners, and a number of ring formers are provided for the cone. The internal structure is secured partly by riveting and partly by welding.

3 Attachment to bomb

3.1 The tail is attached to the bomb body by means of four Hook Bolts, shown in Fig.2(b). One of these is shown removed from its hole to show its shape and the special nut. These nuts are operated through holes in the side of the cone, which can be seen in Figs.1(a) and 2(a), by means of a hexagon Allen type wrench. When the nut is tightened the head of the bolt is thrown forward by the wedge formation shown and the hook falls into the appropriate one of four slots in the side of the base of the bomb. These slots can be clearly seen in Fig.1(b). The bolt at the bottom of Fig.2(b) is shown in this tightened position, while each of the remaining two is held back, to clear the appropriate slot, by a piece of wire passing through the hole provided in the head.

3.2 As can be seen from Fig.4, there is a recess at the aft end of the bomb forward of the base of the tail. It is therefore necessary to provide a fairing, which is shown in position in Fig.1(a). This fairing is also shown separately in Fig.2(a). The fairing shown is one which was produced for the Type XT1. It was found that there was a tendency for this fairing to be loose after the tail was fitted to the bomb. The production tails will therefore be provided with an improved fairing (No. 30) with a more positive method of tightening.

4 Arming

4.1 The tail is provided with an air vane operated mechanism for arming a pistol in the tail end of the bomb. This mechanism is identical, in principle, with that provided for the tail Type No. 107¹, except that:-

- (a) No Delayed Arming Device is fitted and there is no Safety Pip-Pin. This pin was provided in the Type 107 and other tails to prevent accidental pull-off on the ground which would involve detaching and resetting the delay device. The resetting of the pull-off gear itself is a comparatively simple matter.
- (b) The Arming Vane, which is detachable, as shown in Fig.2(a), is secured on the arming spindle by a bayonet socket arrangement instead of a Pip-Pin.
- (c) There is no provision for jettisoning the arming vane.

4.2 Details of the mechanism are indicated in Fig.3 viz. pull-off lever (7), control spring (8), locking lever (3) and arming fork (4). These, together with the pull-off wire are well shown also in Fig.2(b).

5 Naval Safety Catch

This device, designed to prevent arming at any speed below 140 knots, is exactly similar in principle and operation to that built into the Type 107 tail which is fully described elsewhere⁵. The relevant parts, i.e. control spring (1), washers (2), locking lever (3), arming fork (4), roller (5) and safety catch lever (6) are indicated in Fig.3 and can also be seen in Fig.2(b).

APPENDIX II

Strength Test on 2nd Prototype Bomb Tail Type XT1

(500 lb M.C. Bomb)

(Extract from Armament Stress Section Report No. 591)

1 Specimen

The tail tested was the second (modified) prototype tail with eight stiffening swages along the cone. The first tail, without the swages, had failed at a load somewhat below the required ultimate.

2 Loading

2.1 Load distribution

The loading condition corresponds to the air load on a pair of opposite fins when the bomb is flying at 550 knots at sea level, the incidence of the bomb axis to the direction of flight being 30° .

Unit load on gross fin area : 8.95 lb per sq in.

Gross fin area : 198 sq in.

Total unit load : 1770 lb

This is divided between "fin area" (C.P. at R, R¹) and "cone area" (C.P. at Q) (see Fig.5) in the proportion

74.5% C.P. at R, R¹, i.e. 1320 lb

25.5% C.P. at Q, i.e. 450 lb.

2.2 Factors and test loads

Proof Factor : 1.0

Ultimate Factors : 1.33 for Fins
1.5 for Cone and Attachment

Material Correction Factor : 1.2

Hence:-

Total Test Proof Load : 2120 lb

Total Test Ultimate Load
for Fins : 2840 lb

Total Test Ultimate Load
for Cone : 3190 lb

3 Tabulated results

% of Cone Ultimate Load	Deflection of Fin Tips Relative to Cone		Deflection of Rear End of Cone Relative to Rig ins.	Remarks
	Port Fin ins.	Starboard Fin ins.		
0	0	0	0	Initial Condition
66.7	0.22	0.15	0.57	Proof load
0	0.06	0.02	0.18	Load removed
89	0.27	0.22	0.98	Ultimate load for Fins
0	0.12	0.07	0.46	
100	0.27	0.25	1.22	Ultimate load for Cone. Note (1)
0	0.12	0.05	-	Note (2)

- Notes: (1) At this load there was 0.28 in. movement of the cone away from the rear face of the body.
- (2) The tail appeared undamaged after test. The top attachment bolt was slightly bent. These bolts were of steel of ultimate strength of 65 tons per sq in.

APPENDIX III

Physical Data

and

Calculation of Time Period Factor

(500 lb M.C. Bomb, H.A./H.S.)

Symbols

The following symbols are used in this appendix and in Appendix IV:-

- A Gross fin area, per pair (ft²),
- a_N Slope of normal force coefficient for body of store (including tail cone) = $\frac{\partial C_N}{\partial \alpha}$,
- a_P Slope of normal force coefficient for fins = $\frac{\partial C_P}{\partial \alpha}$,
- B Moment of inertia of store about a diameter passing through its centre of gravity and normal to its axis (lb ft²),
- C_N Normal force coefficient of body of store (including tail cone) referred to its cross sectional area = a_Nα
- C_P Normal force coefficient of fins referred to area A = a_Pα
- d Overall diameter of body of store (ft)
- e Base of Napierian logarithms
- g Acceleration due to gravity (32.2 ft sec⁻²)
- H Constant depending on the physical properties of the store such that
- $$-VM_w = H\left(\frac{1}{2}\rho V^2\right) \quad (\text{unit of } H : \text{ft}^3)$$
- K Damping factor
- ℓ Overall length of store (ft)
- ℓ_G Distance of C.G. from nose (ft)
- M_w Pitching moment characteristic of store defined such that - α VM_w = restoring moment (lb ft) on complete store at α radians displacement from the tangent to the trajectory and speed V along the trajectory (lb sec)
- N Normal force on body (i.e. complete store less fins) (lb)
- P Normal force on fins (equivalent to one pair) (lb)
- T Time period of oscillation of store about the tangent to its trajectory (sec)
- t Time variable (sec)

- V Speed of store along its trajectory (ft sec⁻¹)
- W Weight of store (lb)
- x_N Distance of line of action of N forward of c.g. (ft)
- x_P Distance of line of action of P aft of c.g. (ft)
- α Incidence of axis of store to airflow (i.e. angle of axis of store to tangent to trajectory) (radians)
- ϵ An arbitrary constant (angle in radians)
- θ Angular displacement of axis of store, from tangent to trajectory at time t (radians)
- θ_0 Amplitude angle at arbitrary datum - value of θ when $t = 0$
- θ_1 } Numerical values of any two successive amplitudes
- θ_2 } (on opposite sides of mean or equilibrium line)
- μ Relative density factor, $\frac{W}{\rho \left(\frac{\pi}{4} d^2 \right) l g}$
- ρ Density of air (0.00238 slugs - ft⁻³ at sea level)

Physical Constants

Before carrying out the Stability Trial measurements were made of weight, centre of gravity, moment of inertia (B), and the main dimensions of each store. These measurements, which are tabulated below, enable the non-dimensional Time Period Factor⁴

$$\frac{VT}{l \sqrt{\mu}}$$

to be calculated. The method is shown below.

Period of Oscillation

It has been shown⁴ that the time period of a falling bomb, oscillating about a diametral axis is given by the formula

$$T = 2\pi \sqrt{\frac{B}{-VM_w g}} \tag{1}$$

It is shown below that equation (1) can be written

$$T = 2\pi \sqrt{\frac{B}{H \left(\frac{1}{2} \rho V^2 \right) g}} \tag{1a}$$

where H is a constant depending on the physical properties of the store; hence

$$\frac{VT}{\ell \sqrt{\mu}} = \frac{2\pi}{\ell \sqrt{\mu}} \sqrt{\frac{B}{\frac{1}{2}\rho Hg}} \quad (2)$$

Evaluation of H

By definition,

$$-\alpha VM_w = Px_P - Nx_N$$

Also

$$N = C_N \left(\frac{1}{2}\rho V^2\right) \left(\frac{\pi}{4} d^2\right)$$

and

$$P = C_P \left(\frac{1}{2}\rho V^2\right) A$$

Hence

$$-\alpha VM_w = \left(C_P Ax_P - C_N \frac{\pi}{4} d^2 x_N\right) \frac{1}{2}\rho V^2$$

i.e.

$$-VM_w g = \left(a_P Ax_P - a_N \frac{\pi}{4} d^2 x_N\right) \frac{1}{2}\rho V^2 g$$

which can be written

$$-VM_w g = H\left(\frac{1}{2}\rho V^2\right) g$$

where

$$H = a_P Ax_P - a_N \frac{\pi}{4} d^2 x_N \quad (3)$$

Hence equation (1a)

By Ref.2 $a_P = 2.3$ for a store of this shape

By Ref.4 for a ratio $\frac{d}{\ell} = 0.17$, $a_N = 1.0$.

A is taken as constant for all tails of one type, i.e. in this case $A = 1.375 \text{ ft}^2$ (198 in.²).

The remaining quantities in equation (3) were measured individually for each store.

We can therefore rewrite equation (3), for this store,

$$H = 3.165 x_P - \frac{\pi}{4} d^2 x_N \quad (3a)$$

Centres of Pressure

For the ratio $\frac{d}{\ell} = 0.17$, distance of c. of p, in front of nose⁴ is 0.49ℓ.

Hence

$$x_N = 0.49l + l_G \quad (4)$$

The c. of p. of the fins is taken at 7.5 ins. from the tail end (about $\frac{1}{3}$ of the mean chord behind the leading edge of the fin), i.e. $l - 0.62$ ft from the nose of the bomb.

Now by definition of μ ,

$$l \sqrt{\mu} = \sqrt{\frac{Wl}{\frac{\pi}{4} d^2 \rho g}} \quad (5)$$

and reading equation (2) in conjunction with equation (5) it can be seen that l occurs only as a square root. Also the overall length, l , varies very little from store to store; therefore very little error will result if l is regarded as constant for all stores

$$\left. \begin{aligned} & l \text{ is taken as } 6 \text{ ft } 7 \text{ ins. or } 6.58 \text{ ft} \\ \text{Hence } x_P &= l - l_G - 0.62 \text{ ft} \\ &= 5.96 - l_G \text{ ft} \\ \text{and from equation (4) } x_N &= 3.23 + l_G \text{ ft} \end{aligned} \right\} \quad (6)$$

Calculation of $\frac{VT}{l \sqrt{\mu}}$

Putting the value of $l \sqrt{\mu}$ from equation (5) in equation (2)

$$\begin{aligned} \frac{VT}{l \sqrt{\mu}} &= 2\pi \sqrt{\frac{\frac{\pi}{4} d^2 \rho g}{Wl}} \cdot \frac{B}{\frac{1}{2} \rho Hg} \\ &= \pi^2 \sqrt{\frac{2}{l}} \cdot \sqrt{\frac{B}{WH}} \cdot d \end{aligned}$$

Putting in the values of l and π

$$\frac{VT}{l \sqrt{\mu}} = 3.065d \sqrt{\frac{B}{WH}} \quad (7)$$

Values of $\frac{VT}{l \sqrt{\mu}}$

In the following table the individual values of $\frac{VT}{l \sqrt{\mu}}$ for the six stores used in the trial are calculated. The values of d , l_G , B , W were found by experiment.

x_P, x_N are calculated from equations (6)

H is calculated from equation (3a)

$\frac{VT}{\ell \sqrt{\mu}}$ is calculated from equation (7)

Store No.	1	2	3	4	5	6
ℓ_G (ft)	2.13	2.15	2.13	2.15	2.17	2.17
x_P (ft)	3.83	3.81	3.83	3.81	3.79	3.79
x_N (ft)	5.36	5.38	5.36	5.38	5.40	5.40
d (ft)	1.088	1.075	1.095	1.102	1.088	1.102
H (ft ³)	7.14	7.19	7.09	6.95	6.98	6.86
W (lb)	482	488	476	487	482	490
B (lb ft ²)	553	579	555	632	612	622
$\frac{VT}{\ell \sqrt{\mu}}$	1.34	1.34	1.36	1.46	1.43	1.45

APPENDIX IV

Low Altitude Stability Trial

Evaluation of Constants

Analysis of Film

(500 lb M.C. Bomb H.A./H.S.)

All symbols used in the following are defined in Appendix III.

It has been shown⁴ that the oscillation of the bomb approximately follows the law

$$\theta = \theta_0 e^{-Kt} \cos\left(\frac{2\pi t}{T} + \epsilon\right) \quad (1)$$

From equation (1) the numerical value of the constant

$$K = \frac{2}{T} \log_e \frac{\theta_1}{\theta_2} \quad (2)$$

By taking several values of θ_1 and θ_2 from the curve, Fig. 6, plotted from the film, a mean value of K can be found⁴.

The readings and calculations for T and K for a sample of six bombs are given in Table I. T is read direct from the scale of the curve and K is calculated from equation (2).

Calculation of the non-dimensional stability constants is given in Table II.

The value of μ is, by definition, $\frac{W}{\rho \frac{\pi}{4} d^2 \ell g}$.

Hence

$$\mu = \frac{W}{d^2} \times \frac{1}{0.00238 \times \frac{\pi}{4} \times 6.58 \times 32.2}$$

i. e.

$$\mu = 2.535 \frac{W}{d^2} \quad (3)$$

It is noted that V is assumed to be the same as the speed of the aircraft at release; the value of $\frac{VT}{\ell \mu}$ is, therefore, not strictly comparable with that calculated in Appendix III, where V represents the actual speed of the bomb. The error involved, however, is not considered to be great.

TABLE I

Store No.	θ_1 (Degrees)	θ_2	$\log \frac{\theta_1}{\theta_2}$	$\frac{T}{2}$ (secs)	K (sec ⁻¹)	Mean Values	
						T (secs)	K (sec ⁻¹)
1	34	25	0.308	0.515	0.597	1.03	0.640
	25	18.5	0.300	0.50	0.600		
	18.5	13.5	0.315	0.50	0.630		
	13.5	9.5	0.351	0.545	0.640		
	9.5	6.5	0.378	0.515	0.735		
2	19	14.3	0.284	0.515	0.552	0.99	0.517
	14.3	11.2	0.243	0.485	0.502		
	11.2	8.5	0.278	0.50	0.555		
	8.5	6.8	0.223	0.485	0.461		
3	14	12	0.157	0.53	0.462	1.13	0.422
	12	10	0.182	0.595	0.307		
	10	8	0.221	0.53	0.440		
	8	6.2	0.255	0.61	0.418		
4	27	21	0.253	0.515	0.490	1.00	0.502
	21	15.5	0.304	0.47	0.647		
	15.5	12	0.255	0.515	0.495		
	12	9.5	0.233	0.47	0.498		
	9.5	8	0.174	0.53	0.327		
5	18	14	0.251	0.515	0.487	1.05	0.489
	14	11	0.243	0.53	0.458		
	11	8.5	0.259	0.53	0.457		
	8.5	6.5	0.270	0.515	0.524		
6	14.5	11	0.278	0.61	0.455	1.09	0.460
	11	8.7	0.231	0.53	0.442		
	8.7	7	0.218	0.515	0.422		
	7	5.3	0.278	0.53	0.522		

θ_1 θ_2 $\frac{T}{2}$ are read direct from the curves, Fig.6(a) to (f)

$K = \frac{2}{T} \log \frac{\theta_1}{\theta_2}$ from equation (2).

TABLE II

Store No.	T (secs)	K (sec ⁻¹)	W (lb)	μ	$\frac{K \mu \ell}{V}$	$\frac{VT}{\ell \sqrt{\mu}}$	$\frac{VT}{\ell \sqrt{\mu}}$ by App. III
1	1.03	0.640	482	1028	15.2	1.44	1.34
2	0.99	0.517	488	1066	12.7	1.32	1.34
3	1.13	0.422	476	1002	9.75	1.50	1.36
4	1.00	0.502	487	1012	11.7	1.37	1.46
5	1.05	0.489	482	1028	11.6	1.42	1.43
6	1.09	0.460	490	1028	10.8	1.48	1.45

T, K are mean values taken from Table I

W = weighed weight as recorded in Appendix III

μ = $2.535 \frac{W}{d^2}$ (equation (3))

ℓ = 6.58 ft (see Appendix III)

V = 286 ft per sec (169 knots, see para 3.21)

$\frac{VT}{\ell \sqrt{\mu}}$ in the last column is that calculated in Appendix III

APPENDIX V

Naval Safety Catch: Air Tests
(500 lb M.C. Bomb: Tail Type XT1)

Trial No. BD/15/54

1 The results of air tests to check the Naval Safety Catch Release Torque are given in the table below. For each flight the catch of each tail was set to a given measured arming vane release torque; the aircraft was then flown, the speed being limited to an arranged figure.

Flight No.	Tail Type XT1 Serial No.	Torque Setting lb in.	Max. Speed Knots	Catch Released?	See Note
1	19	6.0	140	Yes	
2	19	6.15	140	Yes	
2	16	7.1	140	Yes	
3	19	7.1	140	No	
3	16	7.35	140	No	
4	19	7.1	150	Yes	
4	16	7.35	150	No	
5	16	7.35	155	Yes	
6	12	8.75	160	No	A
6	28	8.75	160	Yes	B
7	12	8.75	170	Yes	A
8	33	7.65	140	Yes	C
8	2	8.75	140	No	C
9	2	8.75	170	Yes	C

- Notes: A: The torque at this setting was rechecked after flight No. 7, the reading being 9.3 lb in.
- B: The torque at this setting was rechecked after the flight, the reading being 9.0 lb in.
- C: These two tails were set as indicated before being flown on the 6 hour Endurance Trial (BD/18/54). The checks indicated at flights 8 and 9 were carried out immediately after the endurance trial, without any further adjustment.

2 The results tabulated above are plotted in Fig.8. This figure thus indicates the approximate torque setting required to release at any given speed. Any plot above the line AA indicates a torque/speed combination which would be expected not to allow release. Any plot below BB indicates a combination in which release would be expected. Between the two lines the result would not be predictable.

Note:

In almost every case, after release of the catch, when the vane had been rotating at high speed for some minutes, considerable wear at the rear bearing of the arming spindle was noted. In the last flight both vanes broke away. In one case whipping of the spindle had caused it to rub against one of the structural diaphragms about 7" from the bearing, causing the severance of the spindle at this point. The other vane had broken away at the bearing; in this case release of the catch had occurred in the previous flight.

Wear at the bearing is to be expected in the particular circumstances of this trial, when the bomb is retained on the aircraft. In normal dropping conditions such wear would not be expected to cause loss of the vane during the flight of the bomb. Even if this did occur it would certainly be at a point well clear of the aircraft, and would not affect the arming function.

Similar wear takes place on the types 100 and 107 tails, although a breakaway of the vane of this kind has not been previously reported.

	Yes	140	7.5	10	1
	Yes	140	7.5	10	2
	No	140	7.5	10	3
	No	140	7.5	10	4
	Yes	150	7.5	10	5
	No	150	7.5	10	6
	Yes	155	7.5	10	7
A	No	160	8.75	15	8
B	Yes	160	8.75	30	9
A	Yes	170	8.75	15	10
D	Yes	180	7.5	10	11
E	No	180	8.75	10	12
C	Yes	180	8.75	10	13

RESTRICTED

Technical Note No. Arm 566

APPENDIX VI

Functioning Trials

(500 lb M.C. Bomb: Tail Type XT1)

Trial No. BD/17/54

1 The results of Live and Safe drops are given in the table below. Details of the stores were:-

Bomb : 500 lb M.C. Mk.18
Tail : Type XT1
Pistol : No. 75
Tail fuizing : Instantaneous detonators.

Number of Flight	At Height (ft)	Speed Kts. (T.A.S.)	Dropped Live		Dropped Safe		Number Satisfactory
			Number	Failures	Number	Failures	
6	10,000	190	4	1	2	-	5
3	19,000	204	2	-	1	-	3
3	20,000	205	2	-	1	-	3
2	27,000	210	2	-	-	-	2
6	29,000	227	2	-	4	-	6

2 Observation from the ground and aircraft gave indication of good ballistic properties.

3 After the first flight during which the one failure occurred, the aircraft was examined to discover any apparent explanation. None was, however, discovered. The fuizing unit on the aircraft appeared to have functioned correctly.

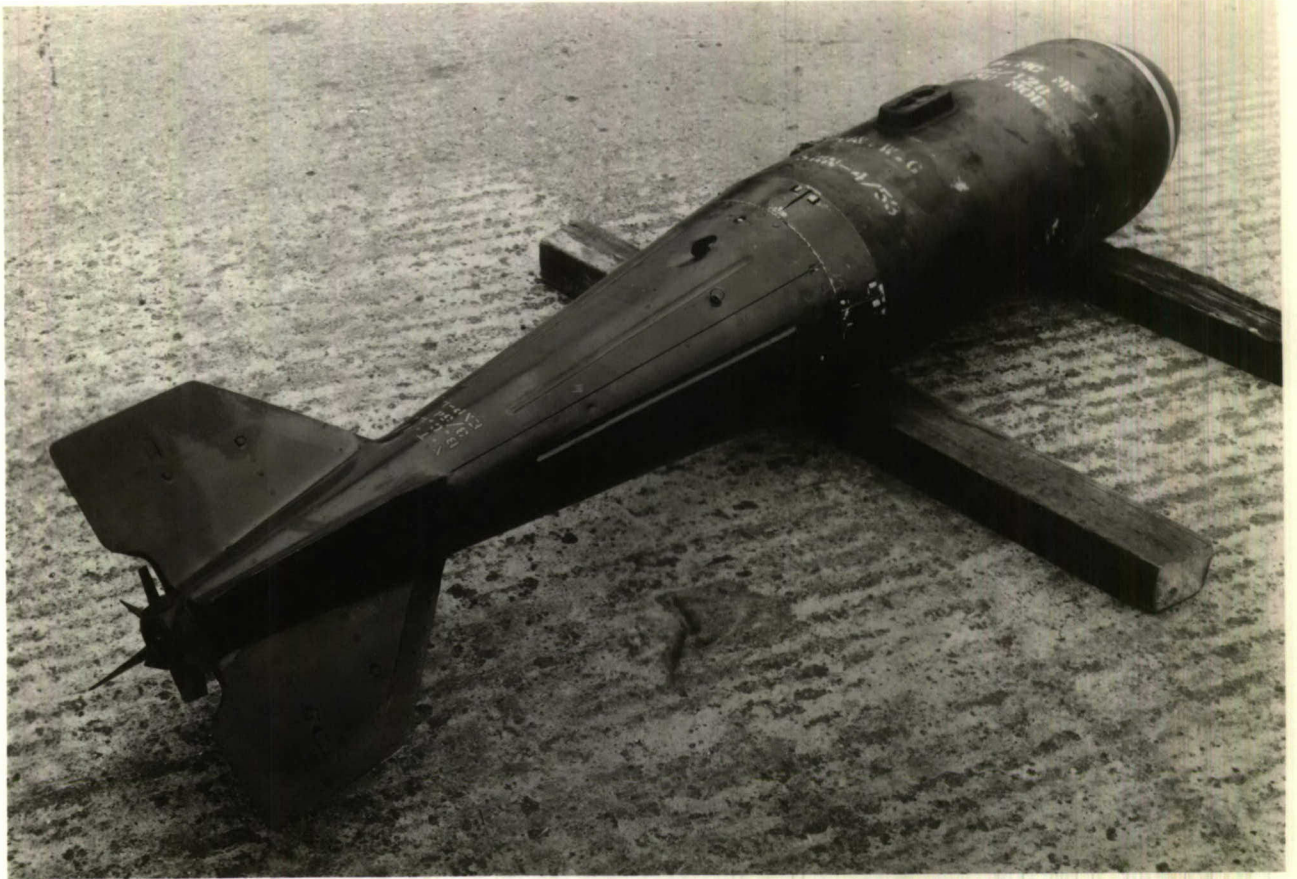

FIG.1a. 500 lb M.C. BOMB WITH TAIL TYPE XTI



FIG.1b. 500 lb M.C. BOMB BODY Mk.18 SHOWING AFT END AND LIFTING PLATE

FIG.2

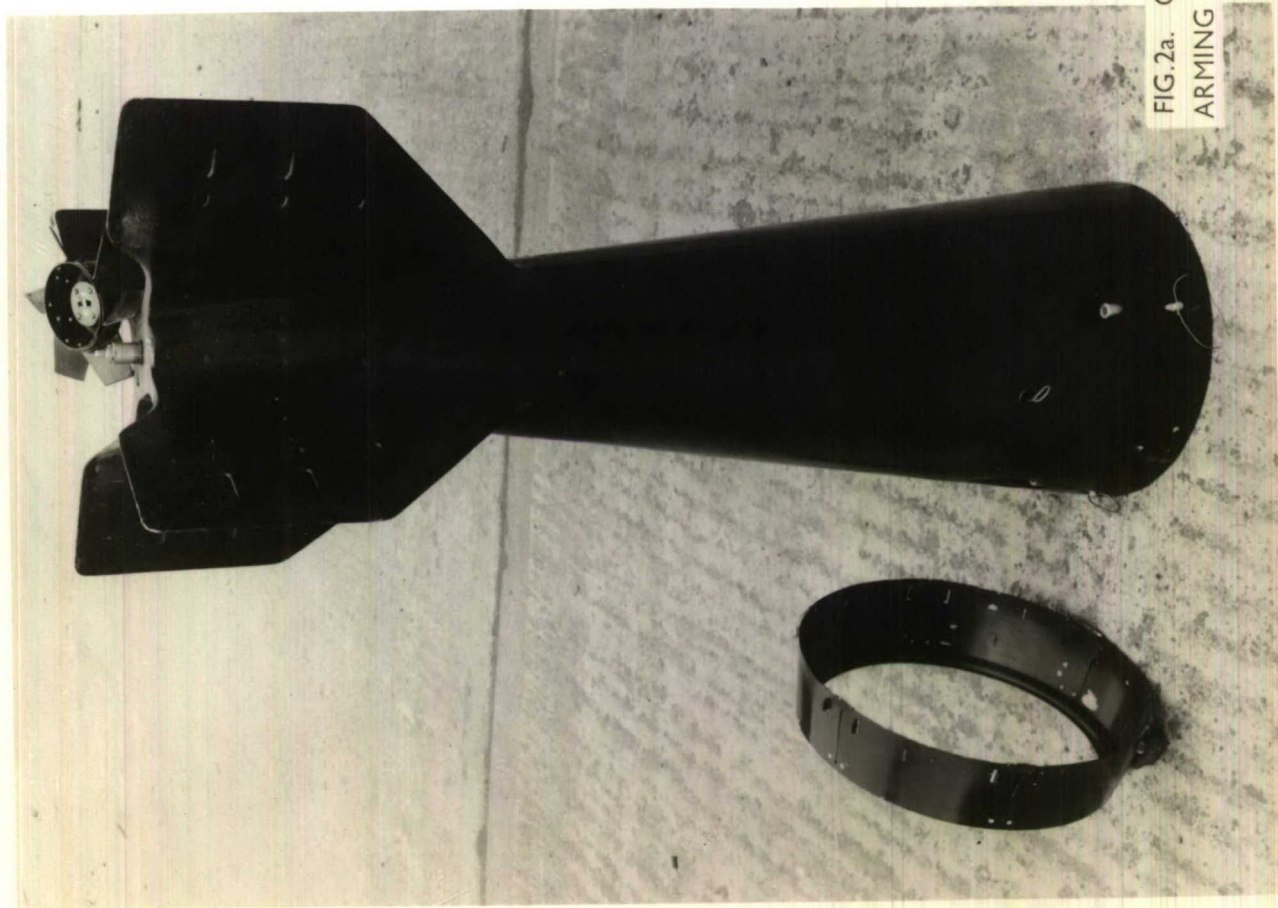

FIG.2a. GENERAL VIEW OF TAIL SHOWING
ARMING VANE AND FAIRING DETACHED

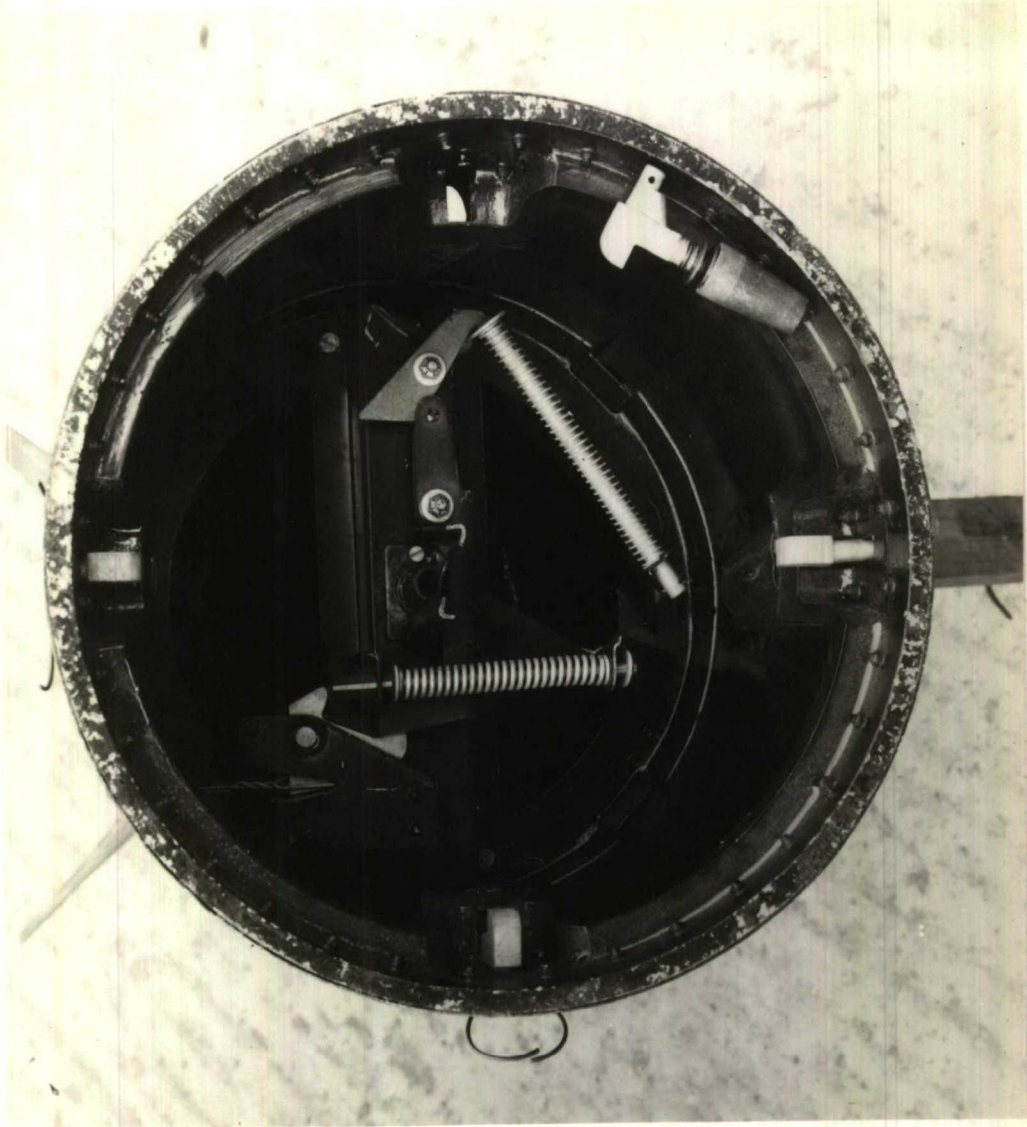
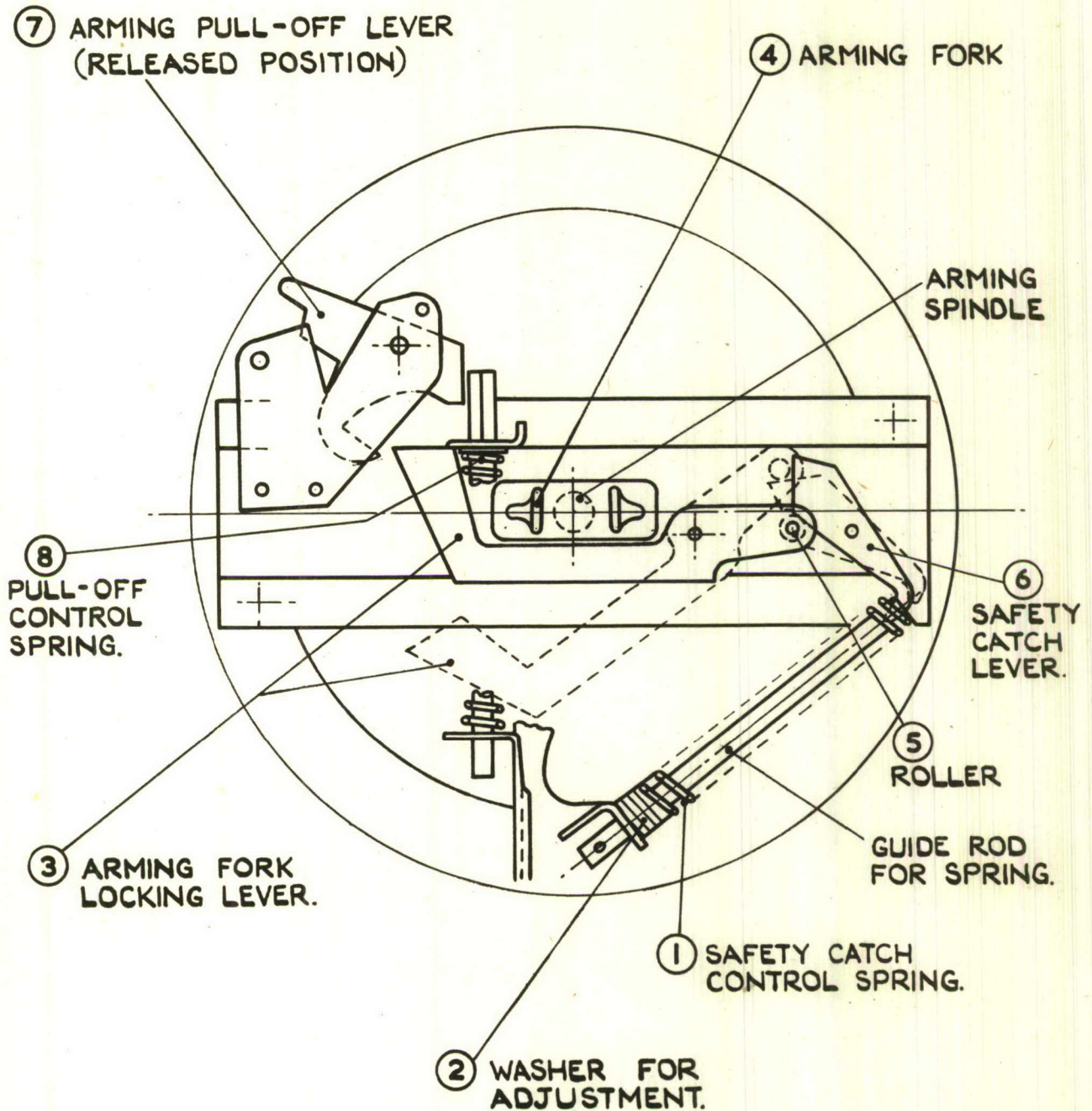

FIG.2b.
INTERIOR VIEW SHOWING ARMING MECHANISM AND ATTACHMENT BOLTS

500 lb M.C. BOMB TAIL EXPERIMENTAL TYPE XT1
(EXPERIMENTAL VERSION OF TAIL No.112)



RELEASED POSITIONS OF LOCKING LEVER AND SAFETY CATCH LEVER SHOWN IN BROKEN LINES.

FIG. 3. DIAGRAM OF ARMING RELEASE MECHANISM FOR BOMB TAIL TYPE NO. 112. (500 LB. M.C.)

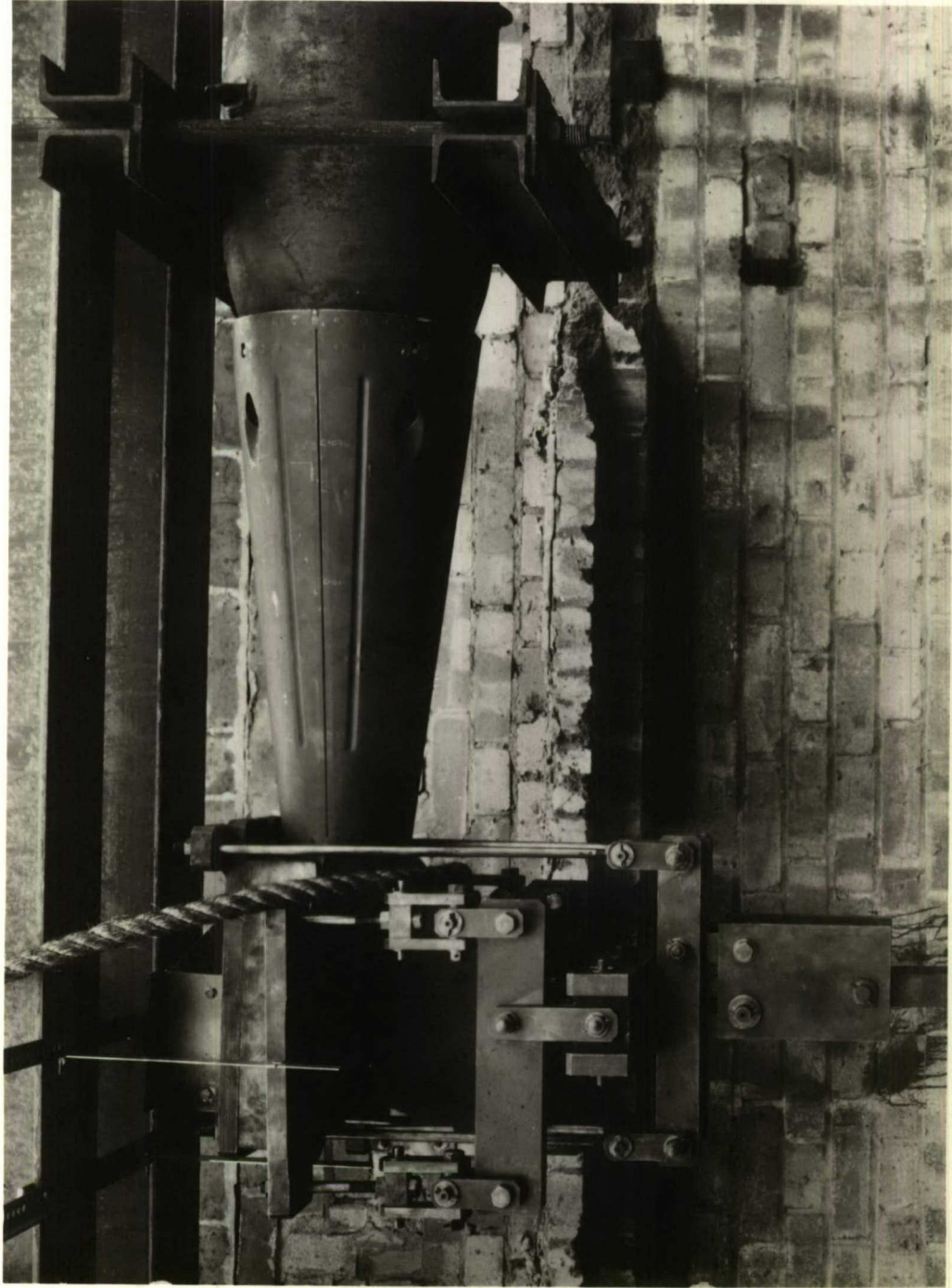
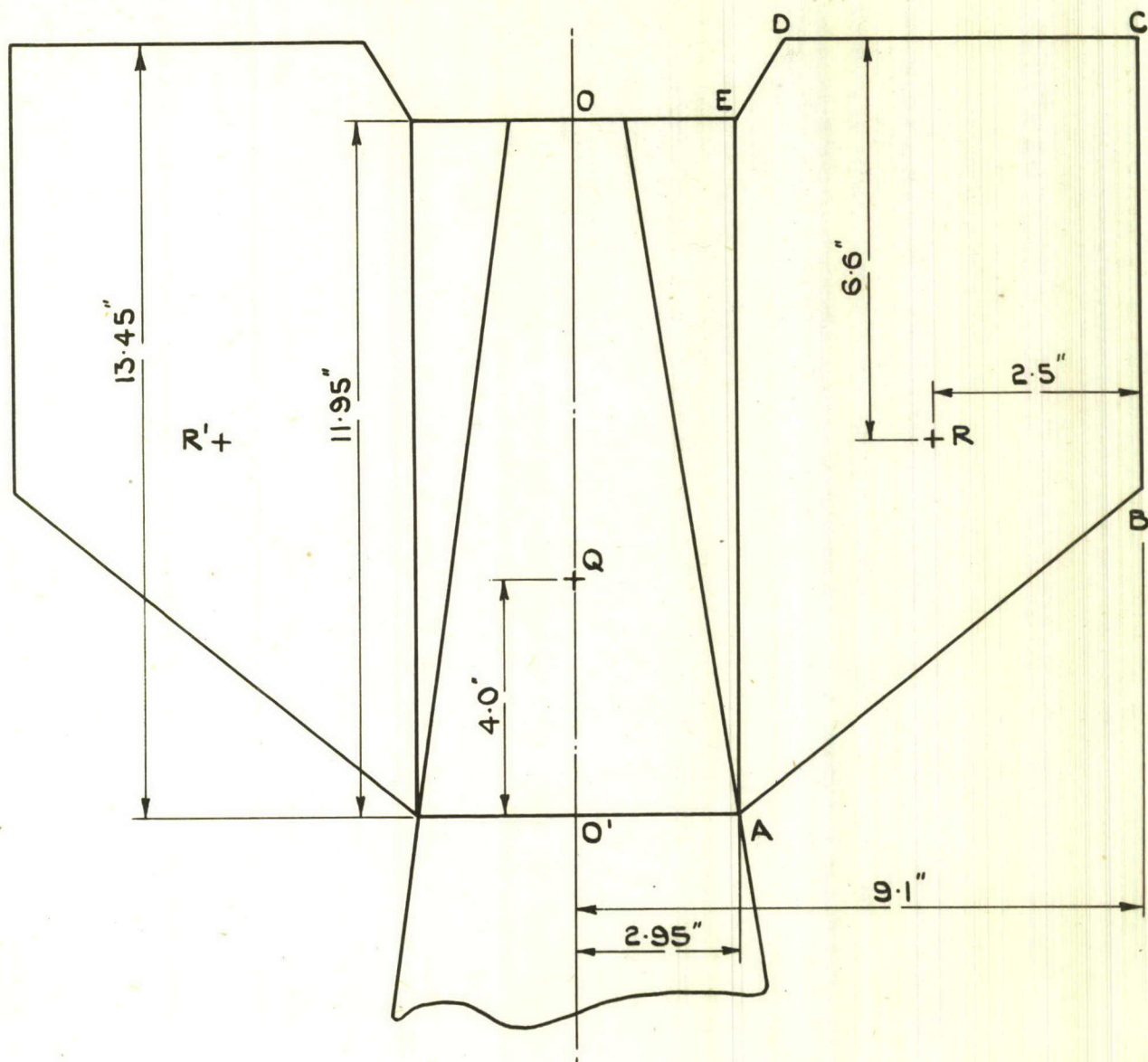

FIG.4. STRENGTH TEST ON 500 lb M.C. BOMB TAIL (TYPE XTI)



CONE REGION AREA (OO'AE)	:	35.3 SQ.IN. PER SIDE
FIN AREA (ABCDE)	:	63.4 SQ.IN. PER SIDE
TOTAL GROSS FIN AREA	:	<u>98.7</u> SQ.IN. PER SIDE

LOAD DISTRIBUTION

LOAD ON CONE REGION (C.P. AT Q)	}	25.5 %
LOAD ON FINS (C.P. AT R, R')		

FIG. 5. LOAD DISTRIBUTION FOR STRENGTH TEST ON 500 LB. M.C. BOMB TAIL TYPE XTI.

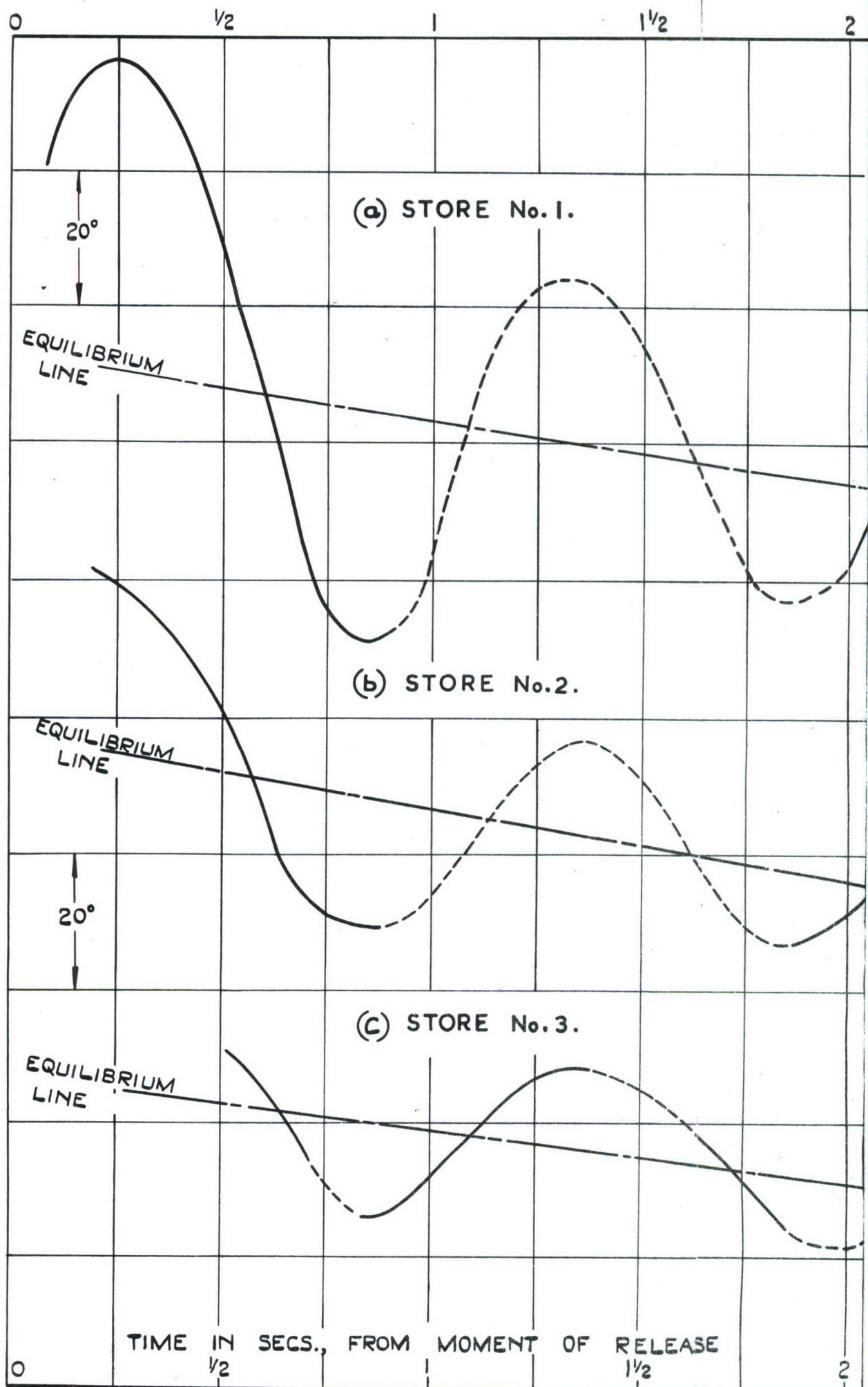
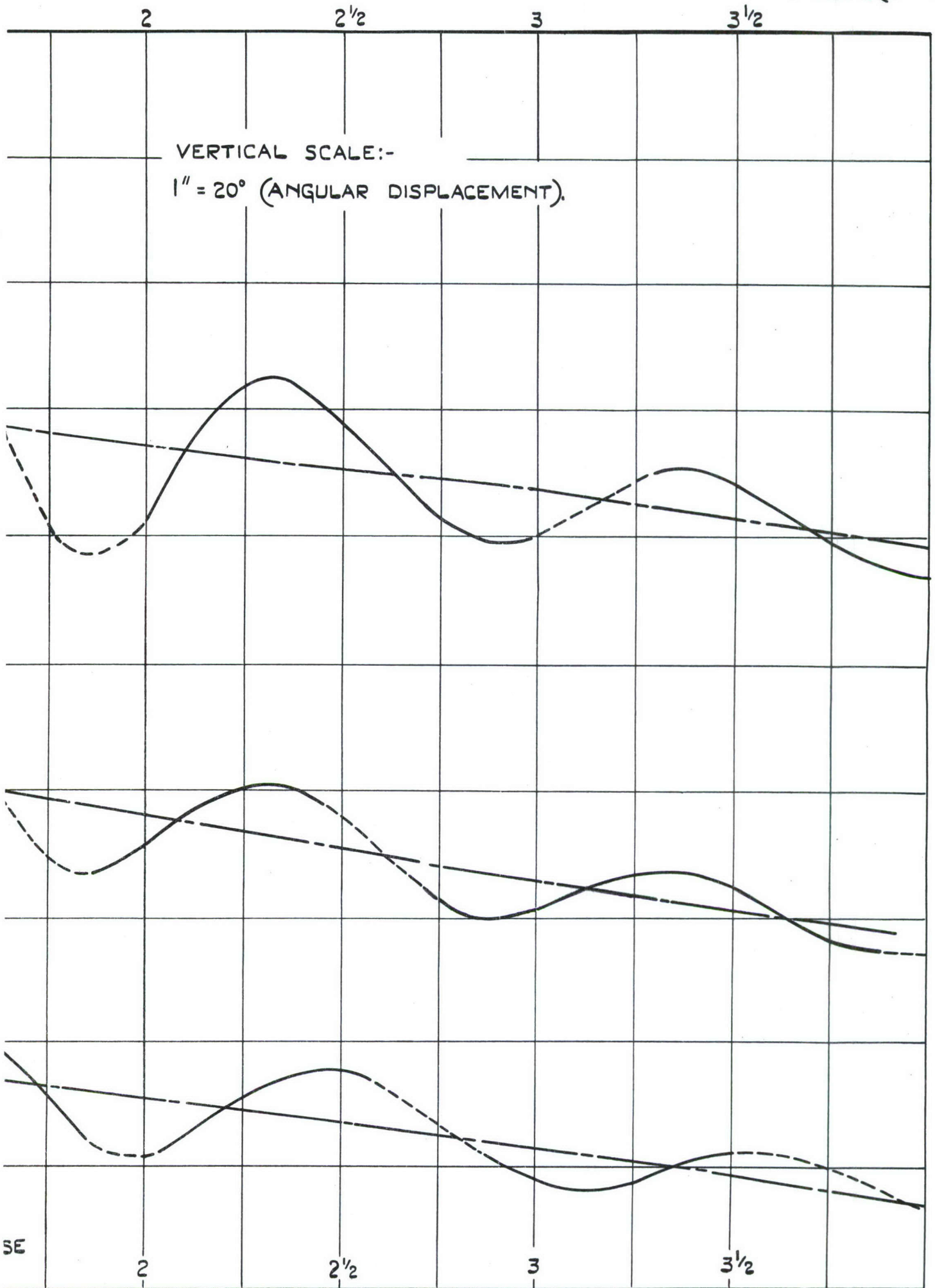

FIG. 6. (a-c). BOMB OSCILLATIONS
500 LB. M.C. BOMB. - TAIL TYPE



IB OSCILLATION CURVES.
TAIL TYPE XT1 (112).

2

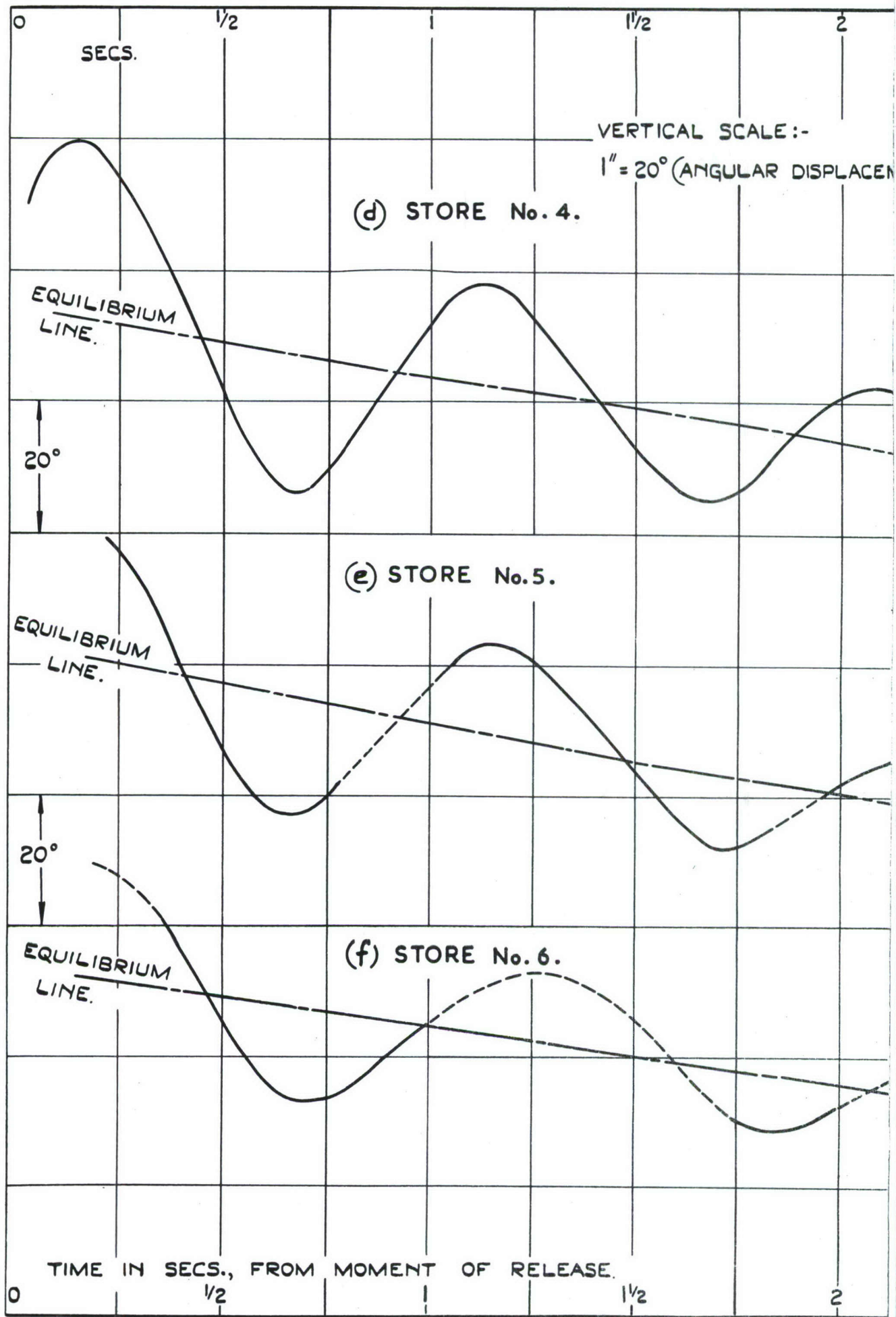
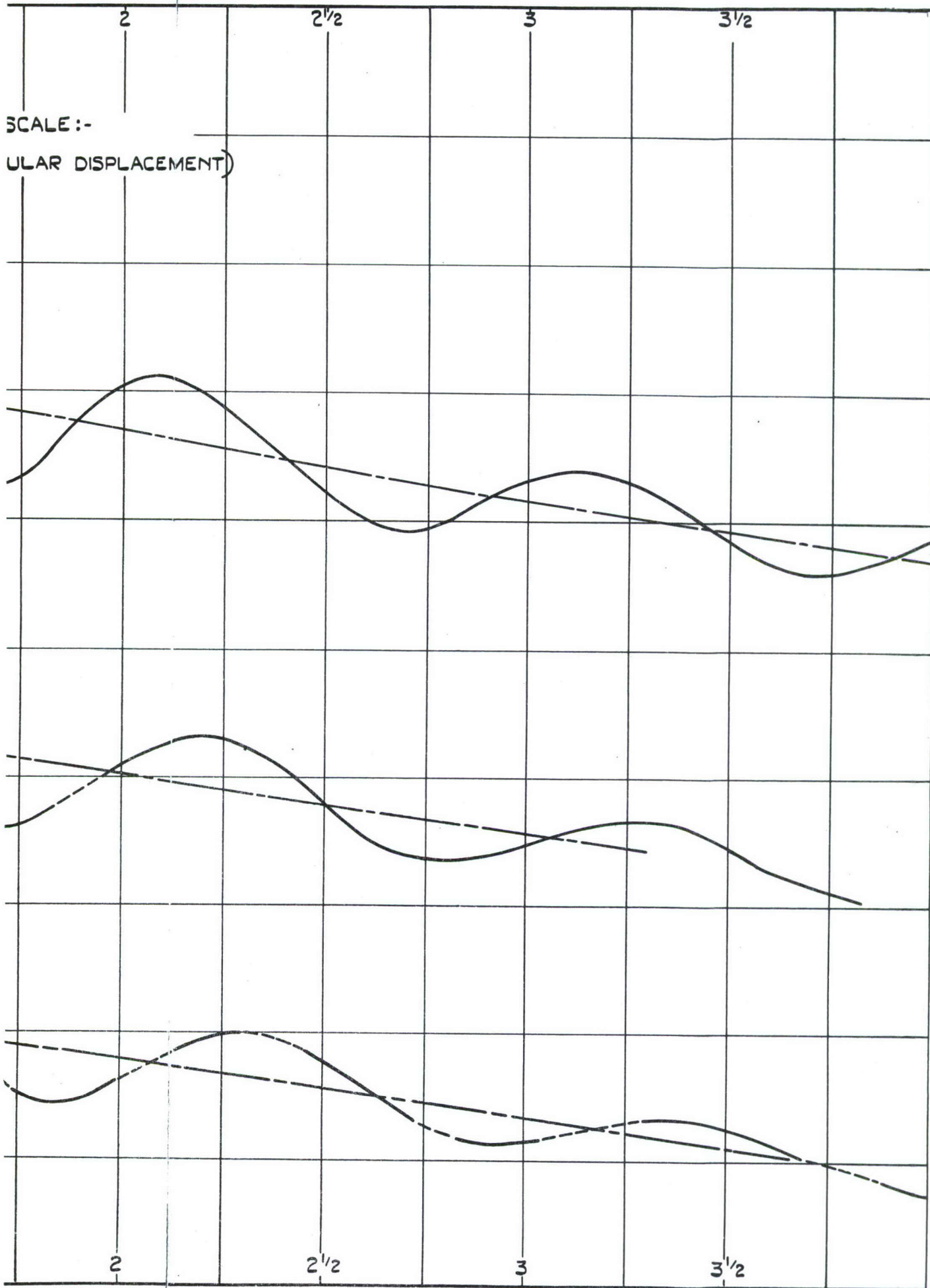

FIG. 6.(d-f). BOMB OSCILLATIONS
500 LB. M.C. BOMB TAIL - TYPE XT

FIG. 6. (d-f).

2



OSCILLATION CURVES.

- TYPE XTI (112).

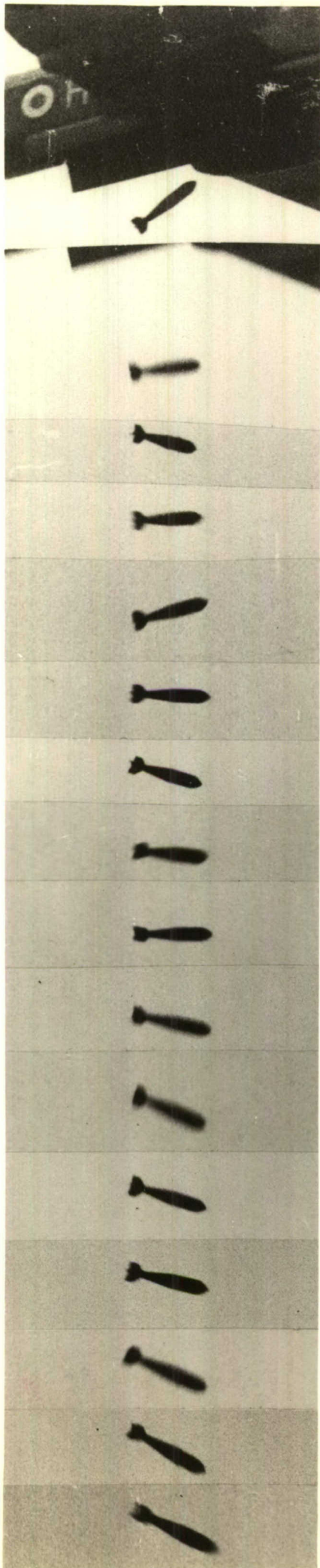

TIME FROM RELEASE	APPARENT ANGLE TO HORIZONTAL OF EQUILIBRIUM POS'N.	APPARENT ANGULAR DISPLACEMENT OF STORE
sec./64	Degrees	Degrees
12	+12	+27
29	+9	0
44	+7	-21
60	+4	0
75	+2	+15½
90	0	0
108	-3	-12
123	-5	0
138	-8	-9½
155	-11	0
172	-14	-7½
188	-17	0
205	-19	+6
222	-22	0
238	-24	-5
252	-26	0

FIG. 7. VIEWS OF OSCILLATING BOMB (500 lb M.C.)
SUCCESSIVE MAXIMUM DISPLACEMENT AND MEAN
POSITIONS SHOWING DECAY OF OSCILLATION

x INDICATES CATCH RELEASED
 o INDICATES CATCH DID NOT RELEASE.

FOR ANY PLOT ABOVE LINE AA
 CATCH WOULD BE EXPECTED NOT
 TO RELEASE; BELOW BB IT WOULD
 BE EXPECTED TO RELEASE.
 FIGURES IN () INDICATE N^o. OF PLOTS
 AT PARTICULAR POINTS.

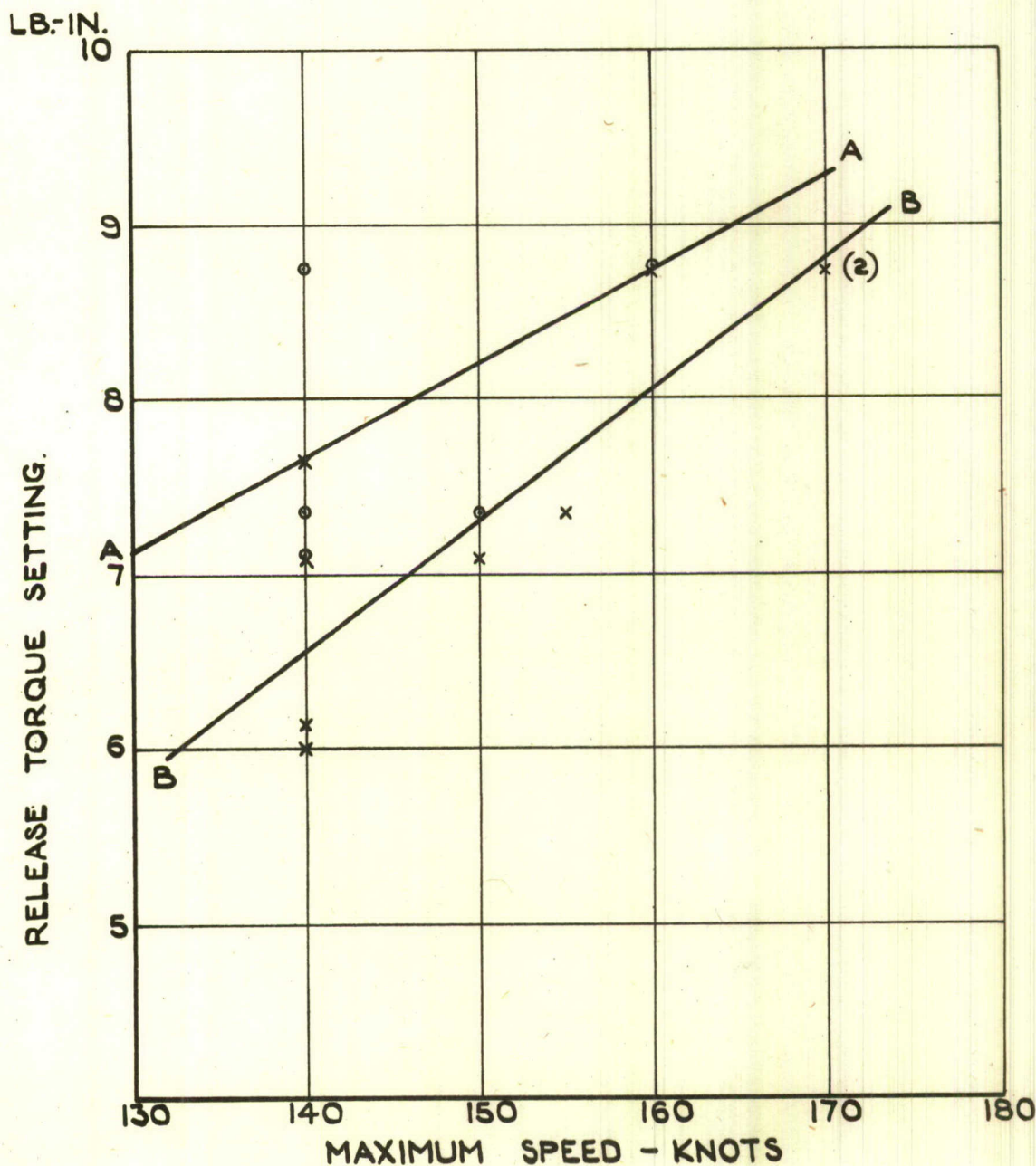

500 LB. M.C. BOMB TAIL TYPE XTI
 NAVAL SAFETY CATCH AIR TEST.

FIG. 8. RELEASE TORQUE SETTING

v
 MAXIMUM SPEED.
 (INDIVIDUAL PLOTS.)

UNCLASSIFIED

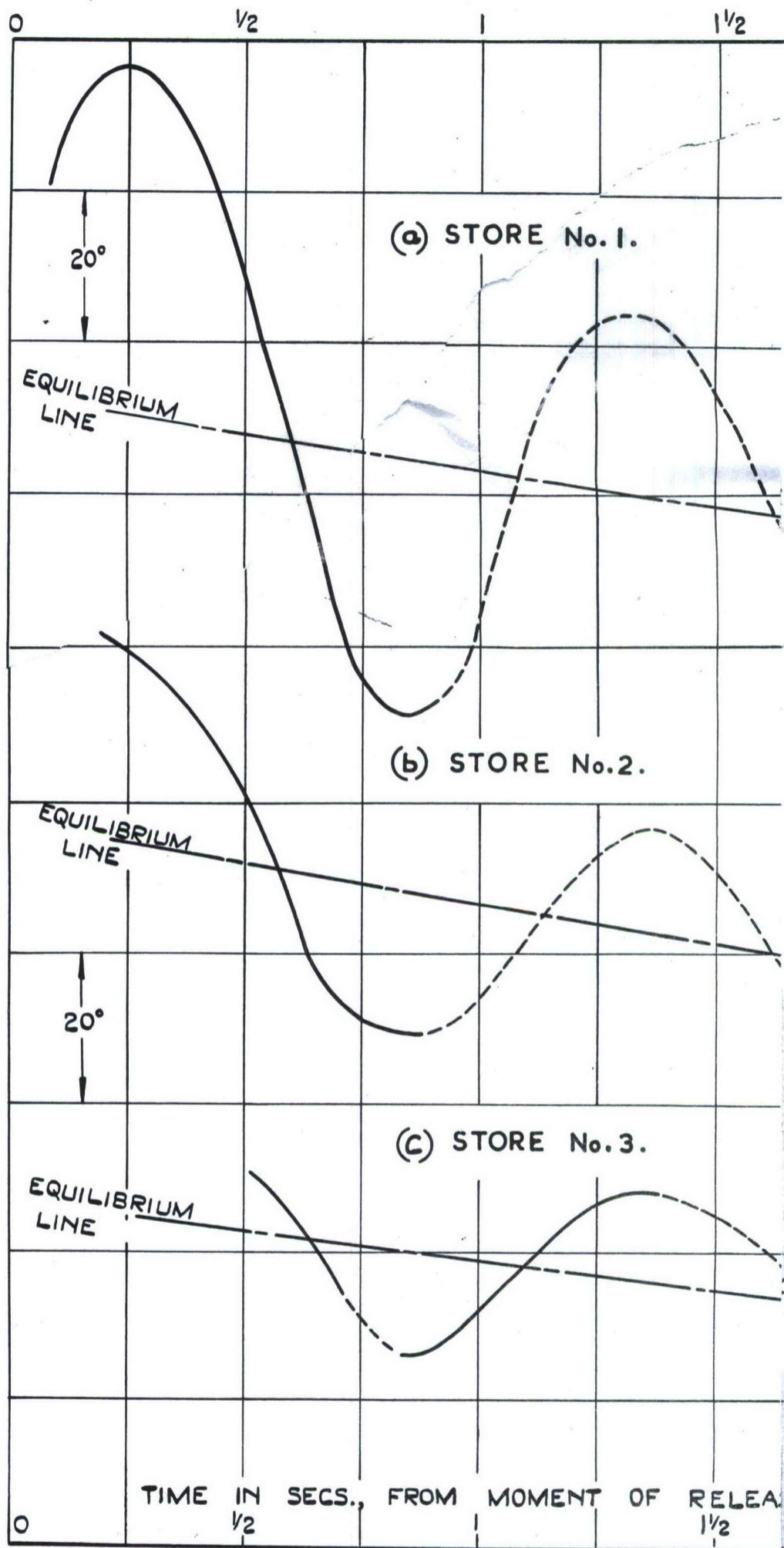

UNCLASSIFIED

FIG. 6. (a-c). BOMB
500 LB. M.C. BOMB.

2

2½

3

3½

VERTICAL SCALE:-

1" = 20° (ANGULAR DISPLACEMENT).

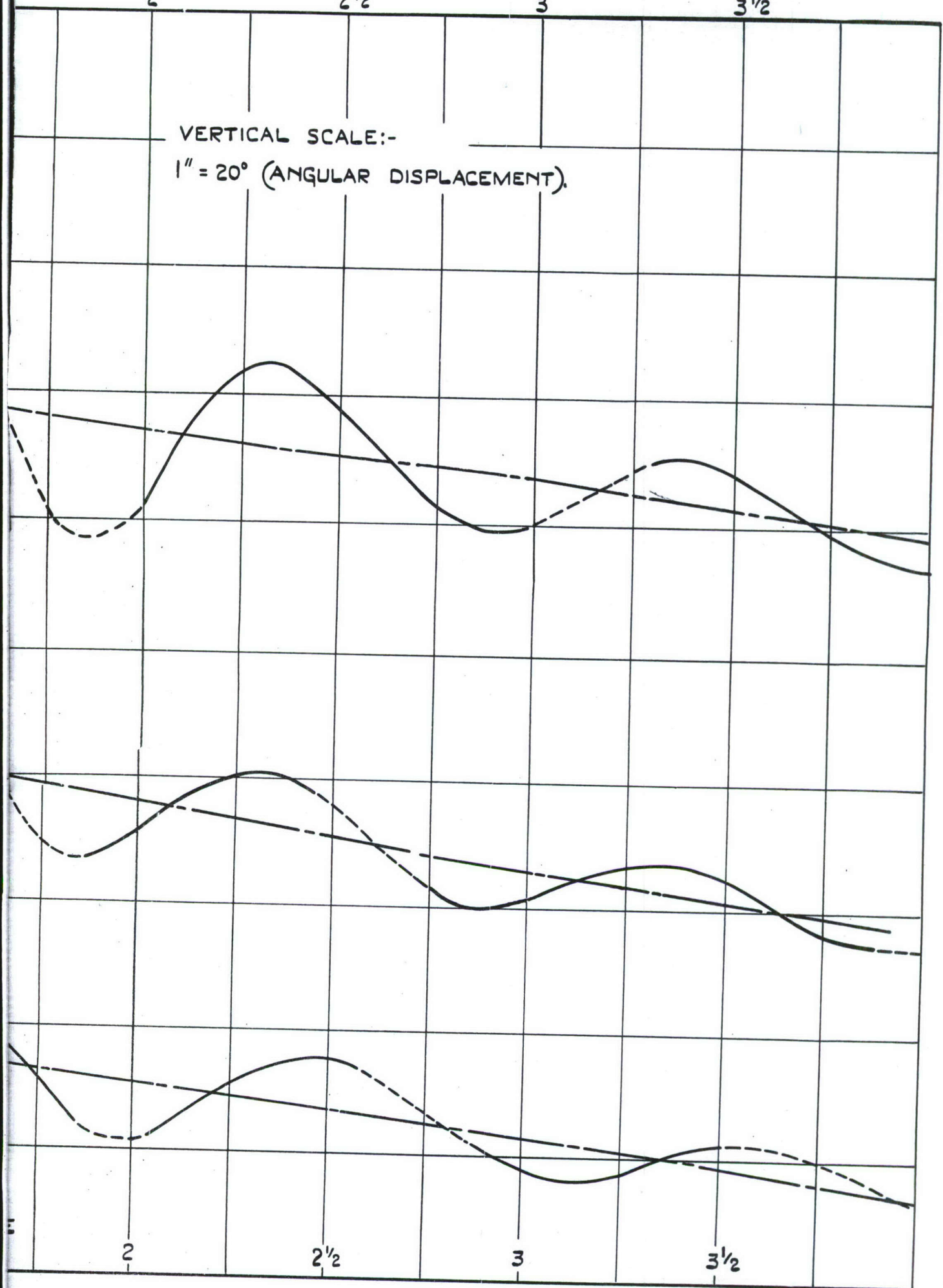

B OSCILLATION CURVES.

TAIL TYPE XTI (112).

UNCLASSIFIED

2

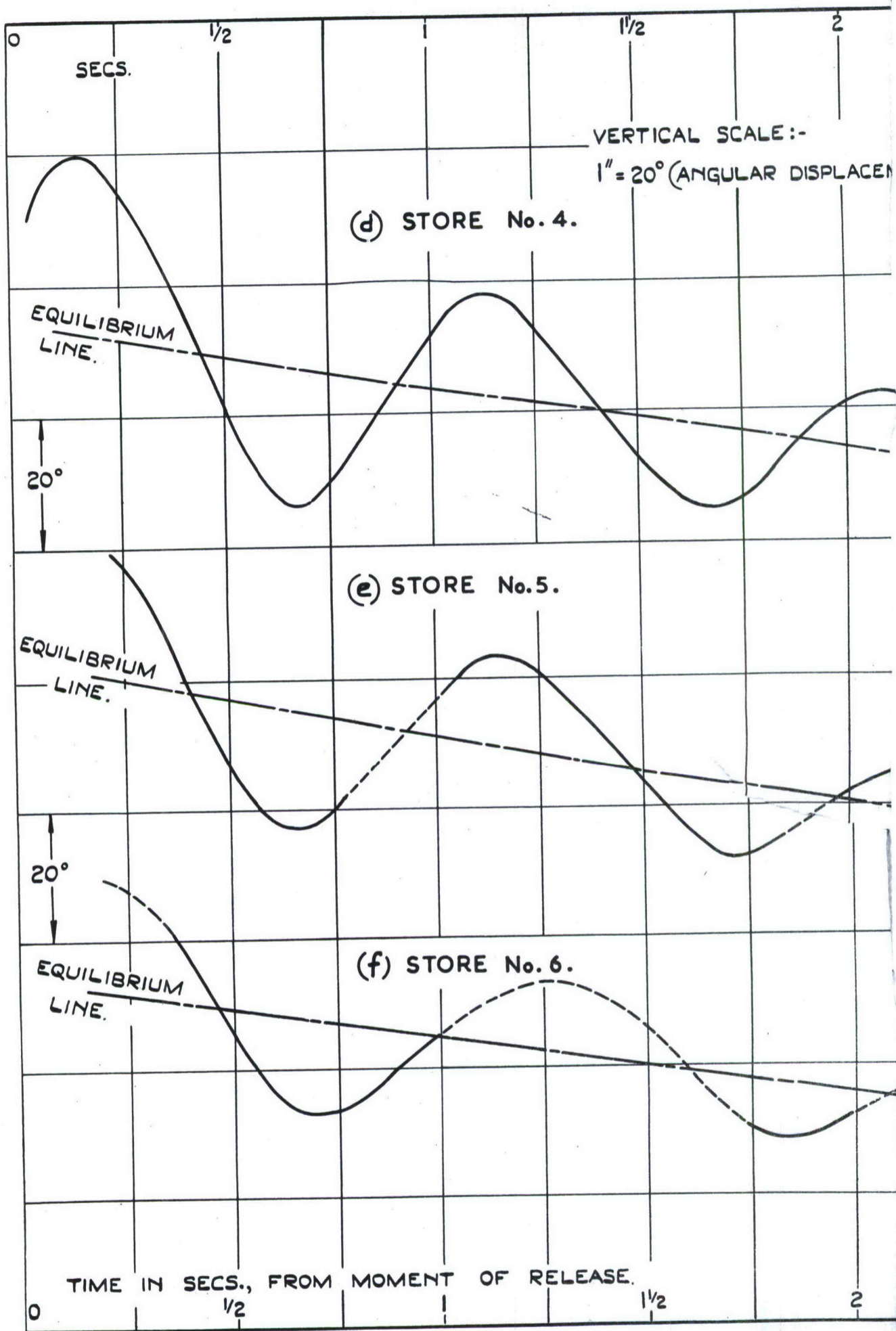
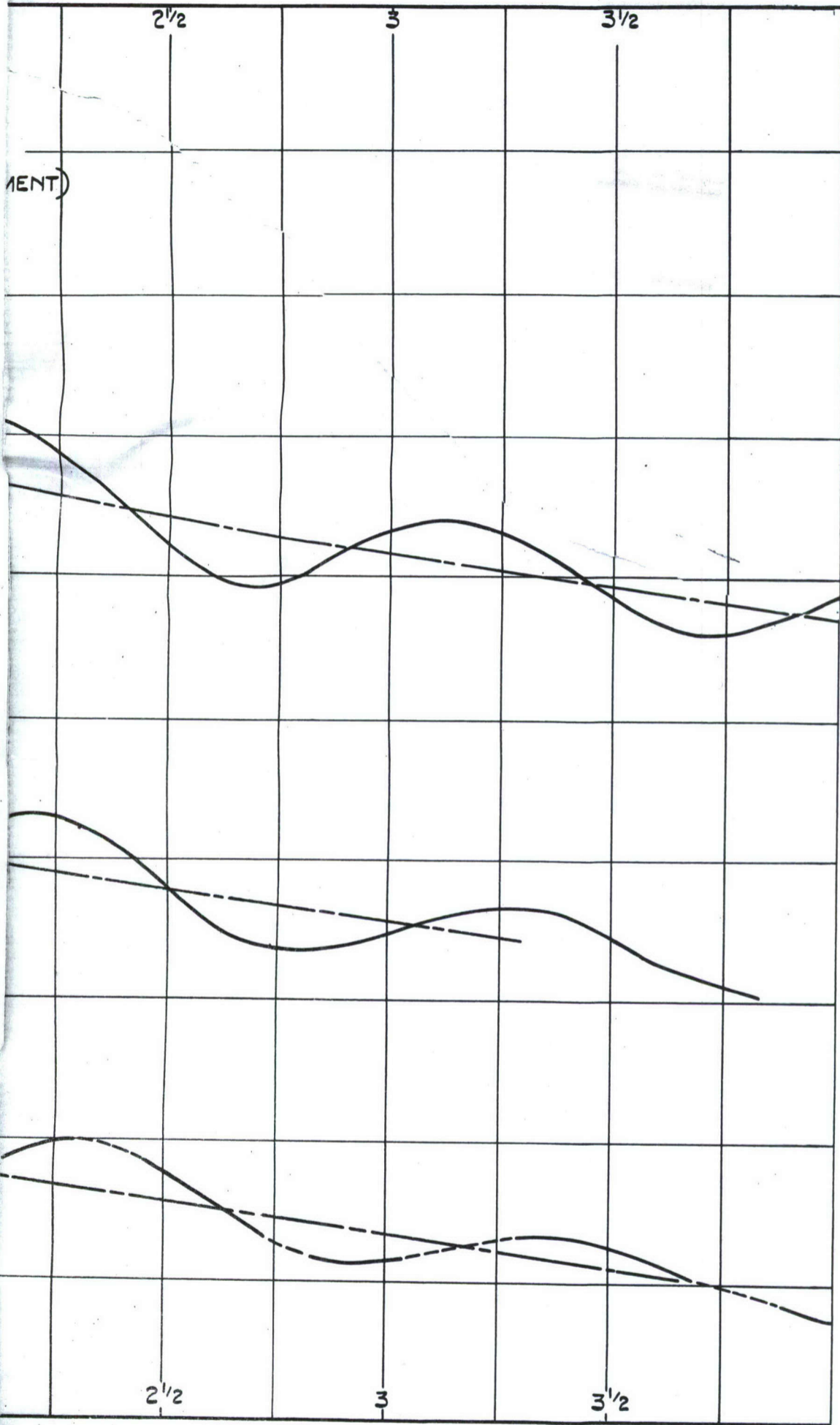

FIG. 6.(d-f). BOMB OSCILLATIONS
500 LB. M.C. BOMB TAIL - TYPE XT
UNCLASSIFIED

FIG. 6. (d-f).



ATION CURVES.

1 (112).



*Information Centre
Knowledge Services*
[dstl] Porton Down,
Salisbury
Wiltshire
SP4 0JQ
22060-6218
Tel: 01980-613753
Fax: 01980-613970

Defense Technical Information Center (DTIC)
8725 John J. Kingman Road, Suit 0944
Fort Belvoir, VA 22060-6218
U.S.A.

AD#: AD071692

Date of Search: 31 July 2008

Record Summary: AVIA 6/19483

Title: Development and trials of a modified 500lb medium charge bomb fitted with a new fixed fin tail

Availability Open Document, Open Description, Normal Closure before FOI Act: 30 years

Former reference (Department) TECH NOTE ARM 566

Held by The National Archives, Kew

This document is now available at the National Archives, Kew, Surrey, United Kingdom.

DTIC has checked the National Archives Catalogue website (<http://www.nationalarchives.gov.uk>) and found the document is available and releasable to the public.

Access to UK public records is governed by statute, namely the Public Records Act, 1958, and the Public Records Act, 1967.

The document has been released under the 30 year rule.

(The vast majority of records selected for permanent preservation are made available to the public when they are 30 years old. This is commonly referred to as the 30 year rule and was established by the Public Records Act of 1967).

This document may be treated as **UNLIMITED**.