

UNCLASSIFIED

AD NUMBER
AD072618
NEW LIMITATION CHANGE
TO Approved for public release, distribution unlimited
FROM Distribution authorized to U.S. Gov't. agencies and their contractors; Administrative/Operational Use; Dec 1953. Other requests shall be referred to US Naval Civil Engineering Research and Evaluation Lab, Port Hueneme, CA.
AUTHORITY
NCBC ltr, 24 Oct 1974

THIS PAGE IS UNCLASSIFIED

AD 7 26118

Armed Services Technical Information Agency

**Reproduced by
DOCUMENT SERVICE CENTER
KNOTT BUILDING, DAYTON, 2, OHIO**

Because of our limited supply, you are requested to
RETURN THIS COPY WHEN IT HAS SERVED YOUR PURPOSE
so that it may be made available to other requesters.
Your cooperation will be appreciated.

**NOTICE: U. S. GOVERNMENT OR OTHER DRAWINGS, SPECIFICATIONS OR OTHER DATA
HEREIN ARE FOR YOUR USE ONLY AND ARE NOT TO BE REPRODUCED OR TRANSMITTED IN ANY
MANNER FOR ANY PURPOSE OTHER THAN IN CONNECTION WITH A DEFINITELY RELATED
GOVERNMENT PROCUREMENT OPERATION, THE U. S. GOVERNMENT THEREBY INCURS
NO LIABILITY, NOR ANY OBLIGATION WHATSOEVER; AND THE FACT THAT THE
GOVERNMENT MAY HAVE FORMULATED, FURNISHED, OR IN ANY WAY SUPPLIED THE
SAID DRAWINGS, SPECIFICATIONS, OR OTHER DATA IS NOT TO BE REGARDED BY
IMPLICATION OR OTHERWISE AS IN ANY MANNER LICENSING THE HOLDER OR ANY OTHER
PERSON OR CORPORATION, OR CONVEYING ANY RIGHTS OR PERMISSION TO MANUFACTURE,
USE OR SELL ANY PATENTED INVENTION THAT MAY IN ANY WAY BE RELATED THERETO.**

UNCLASSIFIED

ASNCER/ TM M074
AD No. 22618

FILE COPY

NY 300 007-2
Technical Memorandum M-074

ASTIA
PROTECTION OF BUILDINGS AGAINST
BIOLOGICAL WARFARE

10 December 1953



FC

U. S.
naval
civil
engineering
research
and
evaluation
laboratory
port hueneme,
california

U.S. Naval Civil Engineering Research and Evaluation Laboratory,
Port Hueneme, California

Project NY 300 007-2
Technical Memorandum M-074

PROTECTION OF BUILDINGS
AGAINST BIOLOGICAL WARFARE

10 December 1953

Warren Viessman, E.N. Hellberg, and H.M. Whippo, Jr.

SUMMARY

As part of the Navy's program for developing protective techniques against ABC warfare, the Bureau of Yards and Docks assigned NY 300 007-2 which superseded project NY 300 01B, "Operational Test of Protection for Buildings under BW Attack," to the U.S. Naval Civil Engineering Research and Evaluation Laboratory. The project was developed by the Laboratory with the assistance of the Army Chemical Corps Biological Laboratories.

A protective shelter was pressurized by the Laboratory. Attacks using BW simulants were made against the building by the Chemical Corps Biological Laboratories and evaluated. Their data appear in Special Report No. 171, "BW Evaluation of the Pressurized Building No. 7-635 at the Naval Civil Engineering Laboratory (1952)," and indicate that a pressure of 0.1 in. of water will give adequate protection. It is recommended that further tests be conducted to confirm this fact.

Investigations conducted by the Engineering Experiment Station of the University of Minnesota under contract to the Navy have produced a group of sealing materials which can be applied easily to the inside of structures for protection against infiltration of contaminants and for pressurization.

Pressurized filter plenums designed by the Bureau of Yards and Docks, the Chemical Corps E-35 collective protector, and the electrostatic precipitators developed by the Naval Research Laboratory were tested or evaluated. Personnel shower requisites and techniques were developed at Port Hueneme. As a part of the Bureau's program of slanting construction of buildings toward conversion to protective shelters in an emergency, a portable air lock with shower developed by the Bureau of Yards and Docks was tested, evaluated, found satisfactory and practical. It was found practical to seal and pressurize a 50,000-cu ft frame building.

CONTENTS

	page
INTRODUCTION	1
MATERIALS AND METHODS OF SEALING	2
THE PROTECTIVE SHELTER	5
General Construction	5
Modifications	6
PRESSURIZED FILTER PLENUMS AND FILTER FRAMES	6
PRESSURIZATION AND LEAKAGE CHARACTERISTICS OF THE TEST BUILDING	8
Climatic Data	8
Natural Ventilation Characteristics	9
Occupancy	10
Building Pressurization	10
SIMULATED BW ATTACKS ON TEST BUILDINGS	12
DETERMINATION OF OPTIMUM PRESSURIZATION	13
Conclusions from Optimum Pressurization Tests	13
CHEMICAL CORPS TYPE E-35 COLLECTIVE PROTECTOR	14
SAND AND SOIL FOR AIR FILTRATION	15
SHOWER TESTS	15
Syrup Tests	16
Spot Contamination Tests	17
Results of Spot Contamination Tests	19
PORTABLE AIR LOCK WITH AND WITHOUT SHOWER	20
Description	20
The Test	20
Construction Recommendations	20

CONTENTS, cont'd.

	page
ELECTROSTATIC PRECIPITATOR TEST	21
RESULTS AND DISCUSSION	23
Sealing	23
Pressurization	23
Optimum Pressurization	24
Filter Frames and Collective Protectors	24
Decontamination Showers	24
Portable Air Locks and Showers	24
Electrostatic Precipitator	25
CONCLUSIONS	25
RECOMMENDATIONS	26
REFERENCES	28

ILLUSTRATIONS

figure	page
1 - Spraying window crack with cocoon material	30
2 - Window crack sealed with cocoon	30
3 - Sealing ground pipes passing through celotex ceiling	31
4 - General appearance of the test building	31
5 - Floor plan of the pressurized test building	32
6 - Sliding type window construction	33
7 - Isometric view of pressurized filter plenum	34
8 - Pressurized filter plenum in place	35
9 - Isometric view of unit pressurized filter frame	36
10 - Construction of unit type pressurized filter frame	37
11 - Quick acting cam and lever filter-retaining device	37
12 - Weather instrumentation installed adjacent to test building	38
13 - Weather instrumentation installed within the test building	38
14 - Cambridge helium analyzer.	39
15 - Air-lock exhaust valve	39
16 - Interior of air-lock exhaust valve	40
17 - Air-lock pressure- and flow-regulator valve	40
18 - Entrance to outer air-lock and flow-measurement duct of air-lock exhaust	41

ILLUSTRATIONS, cont'd.

figure	page
19 - Wind pressure chart	42
20 - Pressurization fan	43
21 - Pressurization airflow-measuring duct	43
22 - instrumentation for the determination of electrical power input to pressurization fan motor	44
23 - Inclined manometers and valved manifold for measuring pressurization	44
24 - Resistance to airflow of 21 filters and adsorbers in plenum	45
25 - Building-pressurization characteristics	46
26 - E-35 collective protector	47
27 - Resistance to airflow of E-35 collective protector	48
28 - Approximate shower-spray water-temperature-loss from head	49
29 - Coarse spray from shower head	50
30 - Shower head arrangements used during tests	50
31 - Pressure-flow characteristics of various shower heads	51
32 - Price-Pfister "Perfect Spray" shower head.	52
33 - Speakman "Emergency" shower head and spray.	52
34 - Speakman "Anystream" shower head and spray.	53
35 - Logan Standard "Wizard" shower head and spray	54
36 - Instrumentation used in shower tests	54

ILLUSTRATIONS, cont'd

figure	page
37 - Evaluation of shower techniques	55
38 - Portable air lock and shower connected to test building	56
39 - Portable air lock from shower end, showing canvas connection to building	56
40 - Portable air lock from outer air lock end	57
41 - Portable air lock under test	57
42 - Portable air lock in use during test, showing discarded contaminated clothing	58
43 - Temporary protective shelter equipped with electro- static precipitator	58
44 - Air intake fan mounted on temporary protective shelter	59
45 - Air duct and flow control valve in temporary protective shelter	59
46 - Electrostatic precipitators installed in temporary protective shelter for test	60
47 - Resistance to airflow of two electrostatic precipitators	61

INTRODUCTION

In modern warfare it is imperative that personnel, supplies, equipment, and vital operations be protected from contamination by biological, chemical, and radiological agents. Supplies and equipment can be protected easily in sealed buildings. Where personnel are involved, sealing and pressurization of shelters are required against infiltration of contaminants. Air introduced into the shelter from outside for pressurization and to avoid vitiation must be relieved of harmful bacteria, poisonous gases and vapors, and radioactive particulates. A means of filtering out the solid and liquid particulates is employed in connection with an adsorber for vapors and gases. This is called collective protection.

Where entrance to the shelter must be available during an attack, air locks and decontamination facilities are provided. Previously the Laboratory had made tests on a 20-ft wide by 50-ft long arched corrugated steel temporary shelter¹⁴. As a result of these tests it was considered advisable to further study air leakage, sealing materials for pressurization, air locks, showering techniques, relief damper development, air-purification equipment, decontamination techniques, and to extend the study to include the pressurization of larger buildings of a more or less permanent nature.

In recognition of the need for more information on the above items and in order to extend the study to frame buildings that might be typical of those existing in any theater of operation, the Bureau of Yards and Docks assigned Project NY 300 01B, "Operational Test of Protection for Buildings Under BW Attack," which was superseded by Project NY 300 007-2, to this Laboratory. This project has been developed by the Laboratory with the assistance of the Army Chemical Corps Biological Laboratories. The plan of development for the program was as follows:

1. Investigate materials and methods of sealing.
2. Modify a 50,000-cu ft, one-story, frame building for test as a pressurized personnel shelter, equipping it with relief valves, filtering and pressurization equipment, air locks and decontamination showers.

3. Develop, manufacture, and test a pressurized filter frame or plenum in accordance with the design proposed by the Bureau of Yards and Docks for accommodation of Chemical Corps filters and adsorbents. Make improvements as found necessary.
4. Determine pressure and leakage characteristics of the 50,000-cu ft building, unsealed and sealed.
5. Determine the effectiveness of sealing materials and pressurization by biological attack at 0.6-in. water pressure.
6. Test Chemical Corps type E-35 collective protector in connection with 50,000-cu ft building.
7. Conduct decontamination-showering studies.
8. Construct and evaluate portable air lock and shower developed for use in converting standard barracks type and other buildings into protective shelters.
9. Equip a 20-ft by 50-ft arched, steel, temporary protective shelter with special electrostatic precipitators and test with biological simulant.
10. Determine optimum pressurization required for protection of personnel in a sealed 50,000-cu ft building.

MATERIALS AND METHODS OF SEALING

A study of typical frame buildings that might be found in a theater of operation and might possibly require pressurization and sealing was made by the Engineering Experiment Station of the University of Minnesota¹⁹. This investigation revealed that the principal types of air leakages to be encountered were:

1. Continuous surfaces.

These consist of uninterrupted wall, ceiling, and floor surfaces of concrete, plaster, or similar construction materials.

2. Surface joints.

- a. Flat surface joints such as joints between sheets of plywood.
- b. Intersecting surface joints such as joints between wall and ceiling.

3. Window cracks
4. Door cracks
5. Wall openings such as electrical outlets, plumbing fixtures, etc.

A survey of applicable sealing materials for these various openings, cracks, and joints was made. The materials which appeared to be of practical value were classified in five categories:

1. Calking compounds and fillers.
2. Paints, varnishes, and lacquers.
3. Plastics.
4. Tapes.
5. Weatherstripping and gasket material

Various calking compounds, plastics, and tapes were obtained, applied, and tested under five aging cycles, each cycle consisting of the following exposures:

- 48 hours to dry air at 150 F
- 24 hours to air at -10 F
- 24 hours to air at 150 F and 60 to 90 per cent relative humidity

A strippable plastic material applied with high-pressure spray gun and known as Navy "cocoon" was tested by the Laboratory. It was placed in a low-temperature test cabinet and subjected to -65 F. At this temperature the material became so brittle that it would crack if bent or shatter if struck.

The materials most successfully meeting the Minnesota tests and retaining their desirable sealing and adhesive properties were:

Calking Compounds

<u>Trade Name</u>	<u>Manufacturer</u>
Pecora Architectural Calking Compound	Pecora Paint Co.
Tite-Life Glazing Compound	Truscon Laboratories
Elastic Compound Tape No. 155	Presstite Engineering Co.

Plastic Materials

<u>Trade Name</u>	<u>Manufacturer</u>
Vinyl Coating No. 311-30	American Resinous Chemical Corp.
Geon Vinyl Resin No. 200x20	B.F. Goodrich Chemical Co.
G.E. Cocoon	R.M. Hollingshead Corp.
Auto Paint Shield	Ramsell Products, Inc.
Navy Cocoon No. 52-C-44 (Manufacturer's No. 5049)	R.M. Hollingshead Corp.

Tapes

<u>Trade Name</u>	<u>Manufacturer</u>
Polyken Tape No. 113	Bauer and Black
Permacel Metal Foil Tape No. 11	Industrial Tape Corp.
3-M Wet or Dry Masking Tape No. 202	Minnesota Mining & Mfg. Co.
3-M Flat Back Masking Tape No. 250	Minnesota Mining & Mfg. Co.

These materials have been found most suitable for sealing buildings to be pressurized, where temperatures within the building are commonly maintained between -10 and 150 F. Selection depends on the particular type of crack or opening to be sealed and upon the facilities available. Specimen windows in the test building were sealed with the architectural caulking compound, with Polyken 113 cloth tape, with 3-M wet or dry masking tape and with Navy cocoon. The caulking compound was applied with a gun and was quite effective for windows to be sealed permanently. Both tapes were found to adhere poorly on dusty surfaces, and had a tendency to tangle during the application. Where a suitable air compressor and spray gun were available, the cocoon material was found to be the most satisfactory sealing agent.

All sealing materials should be applied to the pressure side or inside of the buildings, preferably at temperatures between 50 and 90 F. With the exception of the doors which were weatherstripped, the 50,000-cu ft test building was sealed almost entirely with Navy cocoon No. 52-C-44. This was applied with a Binks Model 10 spray gun with a No. 66 fluid nozzle and No. 63PB air cap. The application was made in accordance with the manufacturer's recommendations¹³. Figure 1 shows the cocoon material being sprayed over a window crack, Figure 2 the window crack sealed with cocoon. Figure 3 shows sealing of a large opening around heating pipes that pass through a Celotex ceiling.

THE PROTECTIVE SHELTER

A study made by the Laboratory of the protective shelter, herein referred to as the test building, has been described in a previous report¹⁵. The building's dimensions are: 161 ft long by 31 ft wide, 9 ft high under the eaves and 15 ft under the ridge. The total floor area is about 4800 sq ft and its gross volume approximately 52,000 cu ft. The net volume, less construction, filter-plenum chamber, air locks, undressing room, and decontamination showers, is approximately 48,000 cu ft.

General Construction

The building is rectangular, one-story, and has a pitched roof with the ridge centered longitudinally with the building. It is erected on a concrete slab on grade construction. Figure 4 shows the general appearance of the building, Figure 5 the floor plan and location with respect to the prevailing winds. The framework is of the usual 2x4 wood studding, and the external and internal walls are of 1/2-in. painted gypsum board. Joints were made over the studding, and no sealing tape or caulking material was used on the outside, except in a few instances where large openings existed. Originally, the outside joints were made reasonably watertight by covering with wood stripping. No effort was made to seal the base plate except that the gypsum board overlaps the foundation to form a weather barrier. The roof overhangs the walls and affords them some weather protection. No special provision was made to seal between the roof and walls. The ceiling in the small rooms and corridor in the front half of the building is 9 ft high. The ceiling in the main portion of the building is covered with Celotex instead of gypsum board and vaulted to a height of 14 ft at the center. The two small rooms in the rear of the building have no ceiling.

The outside doors are of the conventional wood-panel type, single or double, are metal weatherstripped, and each contains a single pane of glass. The windows in the wash and utility rooms are small, hinged at the bottom, and swing in. The majority of the windows are the large Japanese sliding type, running in loosely fitting wooden grooves (see Figure 6).

The roof is fabricated from 1-in. gypsum board nailed to 2x6 rafters and covered with an asphaltic roofing paper cemented at the joints. The roof space is vented at the front of the building through a louver.

Modifications

In order to utilize the building for pressurization and BW investigations, some repairs and alterations were necessary. The outside walls were repaired where damaged, and a solid closure installed to seal the attic louver ventilator. The interior walls were repaired and all electric, plumbing, and heating outlets placed in good condition. Every effort was made to insure tightness consistent with good construction.

Some interior partitions and utilities were removed and the space made available for the pressurization fan, ducts, and test equipment. Partitions were erected and space was provided for the filter-plenum chamber, air locks, showers, and other equipment.

The filter-plenum chamber was constructed for two specially constructed filter frames and was 15 ft 7 in. wide by 11 ft 8 in. deep and was provided with air-intake, louvered, double doors. The Chemical Corps E-35 collective protector was also installed in this room when it was tested.

A six-station intercommunication system was provided including a master station in the dressing room and substations outside the building at the air-lock entrance, in the filter-plenum chamber, in the outer and inner air locks, and in the undressing room. A public address system with speakers on the roof was installed and controlled from the dressing room. A field telephone was provided between the dressing room and the preparation building upwind in the clean area. The building was also provided with telephone service and additional electric outlets, both inside and out.

PRESSURIZED FILTER PLENUMS AND FILTER FRAMES

The pressurized filter plenums used in these tests were designed by the Bureau of Yards and Docks⁴, and were modified to facilitate fabrication. These two units, each accommodating 21 sets of Chemical Corps filters and carbon adsorbers, were constructed of 18-gage steel formed in hollow sections and electrically welded to insure tightness. Considerable warpage difficulty was experienced during construction of the frames, and reworking of the materials was required to obtain proper seating of the filters. The design is not considered practical for production because of space, weight, and fabrication difficulties.

Leakage of contaminated air around the filters and through welds on this frame is minimized by pressurizing the filter frame and the small

space around the filters to 4 in. of water or more with uncontaminated air taken from inside the building. Thus, any leakage, whether internal or external, is clean, safe air.

A test conducted on one of these units at a pressure of 10 in. of water indicated a total leakage for a plenum with 21 filters of approximately 5.25 cfm.

Figure 7 shows isometric sections of the pressurized filter plenum, and Figure 8 the pressurized filter plenum in place.

A light-weight section frame² had been developed by the Army Chemical Corps. This was an integral frame, and not developed as increments of standard units. It was constructed of a special shape, "H" section, extrusion of magnesium. While the frame was of light weight, it was considered that magnesium would be in critical supply in the event of an emergency requiring filter frame construction.

Figure 9 is an isometric view of a pressurized filter frame developed under the direction of this Laboratory for wall or partition mounting. It was designed in an attempt to meet the following requirements:

1. Be compact and lightweight.
2. Be readily portable.
3. Minimize use of critical materials.
4. Provide positive seal around filter mounts and frame connections.
5. Provide for pressurization against possible leakage.
6. Provide for ease in installation and removal of filters.
7. Be suitable for installation in multiple.

The prototype shown in Figure 10 meets most of these requirements. It is constructed basically of a standard 6x4-in., 8-1/2-pound, lightweight steel joist¹⁶. Based on the prototype a complete frame including 21 filters would weight approximately 2800 pounds, which compares with 2640 pounds for the 21 filter Bureau plenum. It is compact and portable, can be assembled into large sizes from standard units and fastening plates, and can be pressurized. Its greater versatility offsets its slight weight disadvantage, which could possibly be improved by further development.

Two types of filter clamping devices were developed. Both appear to be superior to ordinary nuts for quick action in changing filters. One type employs an Acme screw, "U" clamp and wing nut, the other a

cam-operated lever clamp. When the nut is loosened, the "U" clamp which is unbalanced assumes a vertical position so that all vertical fastenings are clear of the filters. It is not necessary to remove the clamps or wing nuts. The horizontal ones have to be turned to clear the filter. The other clamping device shown in Figure 11 makes use of a quick acting cam and lever with the "U" clamp. Some additional minor modifications are in progress which will further expedite the seating and clamping of the filters.

The Laboratory prototype frame was tested for air leakage at 10 in. of water pressure. Leakage was found to be 0.09 cfm per filter or 1.89 cfm on the basis of 21 filters.

This filter frame can be arranged in straight line, U, Z, or other offset shapes as desired, to create a large filter area within a limited space.

PRESSURIZATION AND LEAKAGE CHARACTERISTICS OF THE TEST BUILDING

The natural leakage ventilation of a closed building depends primarily on the type of construction, the state of repair, the temperature difference between outside and inside air, the wind pressure or velocity, and the orientation of the building with respect to the prevailing winds. These factors affect the nature and extent of sealing required for pressurization and the amount of forced or additional ventilation required for a given occupancy. The test-building construction and state of repair has been described previously under the caption THE PROTECTIVE SHELTER, and the orientation with respect to the prevailing winds is shown in Figure 5.

Climatic Data

Wind velocities and direction, and air temperature and humidity were determined by weather station instrumentation at the building. Figure 12 shows the equipment installed adjacent to the test building to obtain outside weather data. Figure 13 shows indicators and recorders within the building for outside wind velocity and direction, a hygrometograph for inside temperature and humidity, and a microbarograph for barometric data.

During the tests the prevailing winds were from the northwest and wind velocity ranged from 4 to 8 miles per hour. The outside

temperature for these periods ranged between 55 and 69 F and the inside temperature between 70 and 82 F. The outside humidity varied between 56 and 90 per cent RH and the inside humidity between 52 and 74 per cent RH. The barometric pressure ranged between 29.79 in. and 29.98 in. of mercury.

Natural Ventilation Characteristics

Under these climatic conditions tests were made on the natural leakage-ventilation characteristics of the test building before and after sealing. The method selected to determine the natural ventilation of the closed building utilizes the helium tracer gas technique¹⁰. The equipment employed is known as the Cambridge Helium Analyzer (Figure 14). The tracer gas is injected to about 2 per cent concentration and thoroughly mixed with the room air by means of fans. Its subsequent rate of decay in concentration is then measured. If there is a complete mixing between the replacement air and the mixed air and gas of the room, the number of air changes in a unit time can be determined from the relationship:

$$R = \frac{\log_e C_0 - \log_e C}{t}$$

where R = number of air changes per hour

t = time, hours,

C_0 = initial concentration of gas, per cent by volume

C = concentration of gas at time t, per cent by volume

By plotting the natural logarithm of the concentration against time, the rate of air change is obtained from the rate of dilution of the helium.

In order to compare leakage ventilation of the unsealed and sealed building, the results were corrected for differences in wind velocities, the airflow being directly proportional to the wind velocity¹². Corrections for temperature difference were not made in accordance with the prevailing assumption that airflow varies as the square root of the temperature difference.

With a wind velocity of six miles per hour, and a temperature difference of 10 F, the natural leakage ventilation rate of the unsealed 48,000-cu ft test building was 0.260 air changes per hour or 208 cfm. The sealed-building-leakage air-change rate was 0.141 per hour or 103 cfm.

Occupancy

As has been shown in a previous report¹⁵, the test building can accommodate 280 persons engaged in light sedentary pursuits, or 230 persons engaged in moderate activity if 5000 cfm of fresh air is provided. This is a rate of 17.8 cfm per person at rest, an occupancy of 171 cu ft per person, and floor area of 13.6 sq ft per person.

For a limited period the population could be doubled, but body odor levels might become nauseating after an extended period. With a loading of 600 persons, 8.35 cfm per person would be supplied by the 5000 cfm fresh air unit. But while the carbon-dioxide content would be below 0.6 per cent and the oxygen supply ample for existence, still, under these conditions, an excessive amount of lung action or fatigue would result.

Building Pressurization

Pressurization with purified air to avoid vitiation and infiltration of contaminants is a desirable protection that has become standard practice. Pressurization is also an advantage in reducing contamination by persons entering the shelter through air locks from a contaminated area.

The amount of pressurization would appear to be a function of the wind velocity or pressure that might be experienced in the area. Ideal pressurization would be such that the building pressure would be equal to or greater than the highest wind pressure to be expected in the area. Pressurization to 0.6 in. of water is the currently accepted design figure. This pressure is applied to the main shelter area. Reduced pressures of 0.5 are used in the shower and undressing rooms, 0.4 in the inner air lock, and 0.3 in the outer air lock.

An airflow of 400 cfm is considered desirable through the air locks. This air exhausts overboard carrying with it a certain amount of contamination picked up by shake-off from persons entering the air lock from the outside. In the pressurization tests conducted by the Laboratory the air-lock relief valve shown in Figures 15 and 16

and designed by the Army Chemical Corps, was adjusted for a flow of approximately 400 cfm. An additional 250 cfm was exhausted through the shower-room ventilation duct which helped control humidity. Airflow between the dressing room, showers, undressing room, and air locks was regulated by wall valves of the type shown in Figure 17. In addition a small relief valve was provided in the exterior wall of the contaminated clothing room to relieve and control the pressure in that compartment. Figure 18 shows the entrance to the outer air lock, the air-relief-valve housing and the back-draft elbow and airflow measuring duct. Two larger air relief valves, of BUDOCKS and Chemical Corps design, were installed at the ends of the building and adjusted to maintain the required air pressure and flow in the building.

A pressure of 0.6 in. of water within the building is equivalent to an external wind pressure of about 35 miles per hour (Figure 19), and would protect a poorly sealed building from infiltration due to winds of that magnitude. A pressure of 0.4 in. would afford protection by infiltration from a wind of 29 miles per hour.

Ventilation and pressurization air was drawn into the building through two pressurized filter plenums (Figure 8), with a total capacity of 6300 cfm. The pressurization fan taking its suction from the filters is shown in Figure 20. The size, weight, and cost of this particular equipment are not to be considered typical as the equipment was for general laboratory use and was oversized. The manometer panel mounted on the discharge duct, Figure 20, serves to determine the pressure drop across the filters and airflow of the fan. Figure 21 shows the fan discharge and air measuring duct. A pitot-venturi tube is utilized to measure airflow. The electrical power requirements of the motor were determined with instruments shown in Figure 22. The small centrifugal blower on the floor was used to pressurize the hollow frame of the filter plenum with purified air from the building. Pressure differentials were measured with inclined manometers connected through a valved manifold to tubing as shown in Figure 23.

The pressure drop across the filters in the plenum was determined for various rates of flows (Figure 24). At the rated capacity of 3150 cfm or 37-1/2 fpm, for a plenum, the pressure drop was found to be 4.6 in. This data was taken after about 500 hours use. New filters would have given lower resistance.

With air discharge valves and relief dampers closed, the building was pressurized unsealed and with various amounts of sealing. It had

been determined by survey and estimates³, that 90 per cent of the natural leakage of the building was through the large visible cracks around the sliding windows. It was also considered that interior surfaces of the building would not allow sufficient leakage to warrant further painting or sealing. The doors had already been weather-stripped, so further sealing was devoted to surface cracks, utility outlets, and window cracks.

The results of the pressurization studies are shown (see Figure 25) for the unsealed building with 298 ft of window crack; for the partially sealed building with 217 ft of crack; with 117 ft of crack; and completely sealed. Note that for 5000 cfm, a pressure of 0.3 in. was obtained in the completely unsealed building, and that for 5000 cfm in the sealed building a pressure in excess of 0.8 in. was obtained. These tests were made with inside temperatures from 72 to 76 F, outside temperature from 60 to 66 F, and a barometric pressure of 30.060 to 30.114 in. mercury. Westerly winds prevailed at 4 to 8 mph. Since it was desired to supply a total of approximately 5000 cfm with 400 cfm exhausted through the air lock and 250 cfm through the shower vent, the building relief valves were adjusted to exhaust the excess air.

During the tests using simulated contaminants and 0.6-in. pressurization with approximately 5000 cfm, the air was disposed of as follows:

Air lock	400 cfm
Shower vent	250 cfm
Building relief valve	500 cfm
Building leakage	<u>3850 cfm</u>
Total	5000 cfm

This is equivalent to 6.25 air changes per hour.

The large amount of leakage under pressurization after all visible cracks and openings have been sealed indicates that the minute cracks and pores, negligible around atmospheric pressures, become important as the pressure is increased.

SIMULATED BW ATTACKS ON TEST BUILDINGS

The BW evaluation of a pressurized protective shelter, Building No. 7-635 and re-evaluation of a temporary protective shelter was conducted by the Chemical Corps Biological Laboratories, Camp Detrick, Frederick, Maryland. The complete report on the BW evaluation

and the conclusions are contained in Special Report No. 171 issued by Camp Detrick⁹.

DETERMINATION OF OPTIMUM PRESSURIZATION

Since a properly constructed unpressurized building affords a relatively high degree of protection against a biological attack that could not be expected to last more than 5 minutes, the necessity for expensive pressurization fans and air purifiers or collective protectors may be questionable for some applications. Also, since the power required for pressurization increases with the degree of pressurization, and since a pressure of more than 0.1 in. does not appear necessary from these tests, the question may be asked what is the optimum pressurization?

In order to obtain more information and thus verify or discredit the above hypotheses, further pressurization tests were made at 0.6 in., 0.4 in., 0.2 in., and at a pressurization approaching zero with a very small quantity of air. As in the previous tests, the simulated BW attack was performed by personnel from the Biological Laboratories at Camp Detrick. The results and conclusions of these tests are reported in Special Report No. 171⁹.

Conclusions from Optimum Pressurization Tests

The results of the tests show that when little or no wind is blowing, a pressure of 0.03 in. of water will give satisfactory protection against BW attack. The maximum wind velocity in which a BW attack is practical is assumed to be 15 mph and for this wind pressure, pressurization to 0.1 in. water will afford protection against infiltration. About 1000 cfm is required for the protective shelter tested, if no air is discharged out the relief valves, the air locks, or the vents. For the 0.6-in. pressurization with 5000 cfm, 7 kw of power were required by the 7-1/2-hp motor on the fan. For 1000 cfm at the lower pressurization, less than one-half that power would be required.

As a shelter for a larger number of people, rather than as a work space or control center, it has already been indicated under Occupancy of THE PROTECTIVE SHELTER section, that 600 persons could expect safe shelter without ventilation for over 3 hours in the building when it is hermetically sealed. The 1000 cfm would improve conditions appreciably over minimum requirements and also make possible the use of air locks for entrance and exit during attack. These air locks should exhaust at least 200 and preferably 400 cfm. The effectiveness

of air locks at pressurized stages below 0.1 in. has not been investigated, but it is considered that results would be favorable as long as the locks are continuously washed by at least 200 cfm of purified air.

CHEMICAL CORPS TYPE E-35 COLLECTIVE PROTECTOR

As previously indicated under SIMULATED BIOLOGICAL ATTACKS ON TEST BUILDINGS, the 48,000-cu ft test building was tested and pressurized by a fan and Chemical Corps filters and adsorbers in a pressurized filter plenum of the Bureau of Yards and Docks design. Since the initiation of the project, the Chemical Corps had developed a new 5000-cfm collective protector consisting of a 5000-cfm axial flow fan with 7-1/2-hp motor and a plywood enclosed filter and adsorber unit. This unit, known as the E-35 collective protector weighs approximately 3000 pounds and can be enclosed in a space 14 ft by 5 ft by 5 ft high and minimizes space, weight, and critical material requirements. It is shown on Figure 26 mounted on a wheel truck and rails, ready to be connected to the forced air duct. Changeover was made with the building under pressurization through one plenum while the collective protector was put in place and connected. The pressure drop across the collective protector was measured by inclined manometer shown mounted on the side of the unit.

The pressure drop through the E-35 collective protector is shown on Figure 27 for various airflows after approximately 200 hours' use. It is to be noted that its resistance at a rated load of 5000 cfm after 200 hours was about 3.2 in. water as compared to 4.6 in. at 3150 cfm for 21 Chemical Corps filters and adsorbers mounted in the pressurized filter plenum (Figure 24).

While the gas life and weight of charcoal per cfm of filtered air is not as favorable as that of the M8 carbon units installed in the pressurized filter plenum, its adsorber air resistance is only 1 in. as compared to 5 in. for the M8 at capacity ratings⁸. The lower power requirements and ample gas life, together with the compactness and portability, make it a very suitable unit.

The power requirements of the E-35 collective protector at a flow rate of 5000 cfm and 0.6 in. pressure, was 7.0 kw. The pressure drop across the filter and adsorber unit was initially 2.9 in. of water. This increased to 3.3 in. after two days and remained near this value to the conclusion of the test. These figures may be compared with 7.1 kw for the 15-hp laboratory variable-speed fan and a drop of 3.7 in. across the pressurized filter plenums. The comparison is not absolute, as the

Laboratory fan was operating through a relatively inefficient drive, and at about one-half its rated capacity. Also the filters were only about 7% per cent loaded. In the case of the E-35 collective protector, the duct resistance was excessive for normal applications.

As far as performance was ascertained during these tests, the E-35 collective protector appears to be a development in the right direction, and a unit of desirable capacity, space, weight, and construction, for application to shelters similar to the test building where a high degree of protection or "absolute" filtration is desired.

SAND AND SOIL FOR AIR FILTRATION

Background literature studies made by the Laboratory revealed that some possibility of using natural soil for air filtration existed. A field test setup, for filtering air through a natural soil depth of 3 ft was improvised by the Laboratory. This indicated that a very high resistance to flow existed. Subsequent laboratory testing showed that a dry sand would be the only type of soil that would allow a reasonable airflow. The effect of moisture in the sand was adverse, increasingly so with smaller particle sizes.

The laboratory experiments using various sizes of sand indicated that a sand made up of 0.2 - 0.4-mm diameter particles was the finest material allowing reasonable airflows. With a filter constructed of this sand an airflow rate of 4 cfm per sq ft of filter surface would require a 5 in. water-pressure drop through 12 in. A 5-in. pressure drop is required for a 36-in. deep filter to produce a flow of 2 cfm per sq ft.

No attempt was made to determine the filtration effectiveness of the sand. For practical applications a prepared bed of sheltered dry sand would be required. Additional information on the efficiency and reliability of sand as an air filtration medium is required before it can be used for the purposes of this project.

SHOWER TESTS

Test results of personnel showers at the simulated BW test on the temporary protective shelter at Port Hueneme in 1949 indicated that the showering technique was inadequate¹⁴. In order to determine the most effective technique for the cooperative tests with Camp Detrick, a study of the factors influencing the efficiency of showering was made.

The variables influencing showering efficiency include water pressure, temperature, flow rate, spray pattern or particle size, the

method of scrubbing and rinsing, and the time available. Since the availability of water in many potential operational areas is limited, special consideration was given to developing low-water-consumption methods. In many cases showering time is an important element. Techniques that would be effective in four minutes were assumed adequate.

Two preliminary sets of tests were made on various shower arrangements to determine the most suitable nozzles, number of nozzles, location and arrangement, pressure, temperature, water consumption, and scrubbing techniques.

Syrup Tests

The first preliminary set of tests was made with the subjects coated with dark Karo syrup. The time required to remove the syrup with various temperatures and pressures was determined. The amount of water required, fine and coarse sprays, and washing methods were evaluated and compared.

The results of these tests indicated that shower water temperatures as measured in the supply pipe just before the nozzle should be between 85 F as a minimum and 100 F as a maximum with 95 F the desirable temperature for a comfortable shower. Reasonably warm water was found desirable for adequate quick cleaning. The temperature of the shower spray striking the body was found to be 5 to 15 degrees lower than the temperature at the nozzle, depending on the distance of the parts of the body from the nozzle, as shown in Figure 28.

A coarse spray with water pellets at a relatively high velocity, as shown in Figure 29, was found to be most effective. The flow pressure at the head should be at least 20 psi, which is required for satisfactory operation of most spray heads. Special low-pressure heads are available and should be obtained for conditions where the static pressure is 15 psi or less.

With the proper spray, 3.5 gpm per shower head is satisfactory for decontaminating. When one head is used, it should be shoulder to 6 ft high with an angle 30 degrees from the wall. If water can be spared, a second nozzle is helpful at waist height. When three nozzles are to be used, the most effective location for the third one is directly overhead, as shown in Figure 30. A washcloth or brush was found to be more effective in removing the contaminant than hand washing.

A maximum cleaning time of 4 minutes and 23 seconds was taken for a test regardless of the nozzle or cleaning methods used.

The general approach in all these tests was to progressively test the factors thought to affect the efficiency of bacterial removal, and to eliminate the least effective methods. This was done in order to decrease the number of variables involved. For instance, as soon as testing showed that the use of a brush was more effective than hand scrubbing, all subsequent tests were run using a brush.

Spot Contamination Tests

The next test was to develop a method using bacteria without contamination by an aerosol to reduce the control problem. The method developed used a spot contamination of the body with a suspension of A. aerogenes in buffered dilute nutrient agar. It is thought that this method results in a tenacious contamination at least as difficult to remove as an aerosol contamination.

In this second set of studies, a series of tests was run using spot contamination on the chest and one leg. Bacterial counts were obtained from the contaminated spots before and after showering. The after-showering samples were taken before drying to eliminate the toweling variable. Another series was run using a single spot contamination on the center of the chest, with bacterial counts being obtained at the contaminated area and on three uncontaminated areas at various locations on the upper body. These areas were located at a point five inches to the left and above the center of the chest; five inches directly below center chest; and twelve inches below and to the right of the center chest.

The single spot contamination series was much more valuable as this test method showed whether contamination had been effectively loosened and rinsed away or had been merely spread around.

Bacterial counts were obtained by swabbing the selected skin areas with sterile cotton swabs which then were placed in sterile water bottles. The bottles were shaken thoroughly and samples plated in nutrient agar and incubated at 30 C for 24 hours before counting. Counts recorded were the total count for the area swabbed which was approximately 2 sq in.

Duplicate tests of each shower technique were run. Although this gave insufficient data for confirmed conclusions, the results were indicative and the more complete tests made during the simulated BW attack were based on these results.

The following sequence of scrubbing and rinsing was used for all showering tests. The entire body was soaped and scrubbed, starting with the head hair and working down. Each body area was completely

scrubbed before moving to the next area so that there was no opportunity for missing any parts. Rinsing was deferred until soap scrubbing was completed. The same sequence was followed during rinse scrubbing and each area being rinsed was turned directly toward the water stream and the area thoroughly scrubbed with the hand, washcloth, or brush. Approximately one minute was devoted to rinsing. Hexachlorophene bar soap was used throughout the test whenever soap was used.

The shower stall used during the tests was approximately 34 in. sq. While this is ample for normal use, it proved annoyingly small when used for determined scrubbing. A 36" x 42" stall is recommended as minimum size.

Of the spray nozzles tested, all were of 1/2-in. pipe size, except the Speakman "Emergency" head which was 1-in. Flow-pressure characteristics for most of the shower heads and spray nozzles were obtained and the results are plotted in Figure 31. On this Figure the spray nozzles tested are indicated as follows:

- A - Logan Standard "Wizard" - fine spray
- B - Reocal "April Shower" B-1147 - medium spray
- C - Logan Standard "Wizard" - coarse spray
- D - Chicago Faucet "Brownie" 620-B - medium spray
- E - Logan Low Pressure "Wizard" - fine spray
- F - American-Standard "Boyd" B-266 - medium spray
- G - Reocal "Presto" - medium spray
- H - Crane 9-221 "Economy" - medium spray
- J - Crane 9-238 "Rainbeau" - coarse spray
- K - Wizard "Low Pressure" - coarse spray
- L - Price-Pfister "Perfect Spray" - coarse spray
- M - Speakman "Anystream" - coarse spray
- N - Speakman "Emergency" - deluge type (1-in. IPS)

The Price-Pfister "Perfect Spray" is shown in Figure 32, the Speakman 1-in. IPS "Emergency" head with spray is shown in Figure 33. Figure 34 shows the Speakman "Anystream" with coarse spray pattern. The Logan Standard "Wizard" is displayed with coarse spray pattern in Figure 35.

The instrumentation for the shower tests is shown on Figure 36. It includes integrating and indicating flow meters for three showers, a hot-and-cold-water mixing valve, a pressure regulator, thermometers, and indicating and recording pressure gages

Results of Spot Contamination Tests

Figure 37 indicates the approximate effects of various methods of soaping and scrubbing at various water pressures and flows with continuous and intermittent operation.

These tests indicated that contamination was not properly removed from the legs when a single, shoulder-high, shower head is used and that a scrub brush with soap is the most effective way to cleanse the body. No final conclusions may be drawn regarding exact water temperatures, pressures, or flow rates, although certain minimums are discernible. It is felt that, although no decisive results were obtained, it is important that the water temperature be warm enough for comfort. It is also concluded that at least 4 minutes is required.

The sponge and bucket method was fairly effective but required a longer time and saves only about 1.5 gallons of water. It is awkward and requires greater care in execution.

During the spot contamination tests, the following shoulder-high single shower heads produced the best results with soap and brush washing, 95 F water, and a coarse, high-velocity spray:

1. Logan "Standard," 3.5 gpm at 40 psi, continuous operation.
2. Crane "Rainbeau," 4.8 gpm at 20 psi, continuous operation.
3. Logan "Standard," 4.4 gpm at 60 psi, continuous operation.
4. Logan "Standard," 3.5 gpm at 40 psi, intermittent operation, wet-down period - 15 sec, rinse period - 1 min.

Since the performance ratings of the shower heads and spray nozzles are not based on a particular design but on flow-pressure characteristics, shower nozzles of other manufacturers which have similar flow rates and spray patterns may be equally acceptable.

PORTABLE AIR LOCK WITH AND WITHOUT SHOWER

The Bureau of Yards and Docks has developed a portable air lock designed to be attached to the entrance of a standard barracks or other building designated as a protective shelter under the Slanting Construction Program for protective shelters. A portable collective protector, installed to pressurize all or part of the building, will complete the protection of such a building.

Description

The air locks both with and without shower are made of plywood and mounted on skids. Figure 38 shows a portable air lock with shower connected to the test building by an adjustable canvas and frame connection. This canvas connection is shown in Figure 39. Figure 40 shows the air lock entrance, while Figure 41 shows personnel entering the portable air lock during the simulated BW attack. The manner in which contaminated clothing was discarded from the outer air lock is shown in Figure 42. The air relief valve can be seen above the clothing door and the hose drain is shown on the ground. Power, water, and sampling connections were also provided. Details of the construction features may be obtained from the drawings^{6,7}.

The Test

The portable air lock with shower was used for entrance of personnel to the pressurized building in the same manner as entrance was made through the permanent air-lock system during the previous tests. Building pressure was 0.6 in. water and the pressures through the portable air lock were successively reduced to 0.3 in. water in the outer chamber. Air was exhausted through the air lock at the rate of approximately 350 cfm. Little difficulty was experienced with this structure.

The BW evaluation of the portable air lock was conducted by Camp Detrick personnel. The results of these tests may be found in their report, but it can be stated that the tests were favorable.

Construction Recommendations

The prototype was constructed to evaluate its performance and design prior to final approval and quantity production. The following paragraphs list a number of recommendations for improvement:

The hinges and socket for the anti-back-draft pressure-relief valve should be spot welded in order to minimize buckling of the door plate⁶. The hood should be designed for a 30-degree opening of the door. This would provide ample capacity and decrease back-draft problems.

The clothing pass-door frame should be redesigned to mount the spring catch on the wall and the keeper on the door. A handle should be provided on the door for positive closure. The clothing pass-door in the inner air lock can be eliminated as it is not required in the decontamination process.

The air regulators, shown in Figure 39, between the inner air locks and the shower have metal wing screws threaded into a fiber-board frame. These would not hold. It is suggested that the fiber-board frame be replaced with a metal frame.

The air-lock doors had a 1-in. lap door stop, Detail DCC, Elevation F on the drawing⁷. It is recommended that this overlap be reduced to 1/2 in. which is standard, as the 1-in. overlap interfered with the operation of the door knob and necessitated a cutout as shown in Figure 40. Weatherstripping of the exterior door only is required, and could be eliminated on the inner doors as a matter of economy if the doors are well fitting.

The air locks were designed to use a standard 8-ft length of plywood. This provides greater weight and bulk and because of the increased size, lowers the air velocity through the locks which is undesirable. The structure would be more effective if its height were reduced by 12 inches. This would still permit the use of 6-ft 8-in. doors and a canvas frame and connection to a building door of 7-ft height.

The shower-head outlet is shown on the drawing at 6 ft 1 in. above the floor. This should be specified at 5 ft 8 in. for more efficient showering. A soap dish and brush hook should be provided in the shower.

The portable air lock with shower in other respects appears well-constructed for the purpose intended. Its field of application is extensive and it should be effective in the accomplishment of its objective.

ELECTROSTATIC PRECIPITATOR TEST

The electrostatic precipitator is especially well adapted for the removal of small particulate matter from air streams. It offers advantages of high capacity, high efficiency of removal of small particulates, and low cleaning and replacement costs. High efficiencies are obtained by allowing suitable time for contact in the collector zone, and by proper ratio of airflow velocity to that of transmission velocity of the negatively charged particles toward the positive-charged collector plates. Commercial designs available were not intended for absolute filtration, but some have given efficiencies as high as 99 per cent at velocities of about 100 fpm using special cleaning methods^{17, 18}.

The Naval Research Laboratory, in cooperation with the Westinghouse Corporation, developed a prototype high-performance electrostatic filter based on commercial design¹¹. Through arrangements made by the Bureau of Yards and Docks, two modified Westinghouse V-22 vertical-type precipitators were obtained for tests at this Laboratory. These units, when used separately and without the modifications, have a commercial rating of 1330 cfm at 90 per cent efficiency. The cross-sectional area is 4 sq ft. The rating is, therefore, at a velocity of 332 fpm. The modification consists principally of sponge-rubber packing intended to reduce or eliminate bypassing of the air stream around the ionizer and plate sections. No prefilters were provided for the units.

The building selected for the field test of these units was a 20x50-ft Armco Ammunition Hut, modified for use as a temporary protective shelter¹⁴. It is shown in Figure 43. The sealed building was to be pressurized to 0.6 in. of water at airflow rates of 800 and 1200 cfm, corresponding to 200 and 300 fpm. Figure 44 shows the installation of the double-inlet, double-width centrifugal blower mounted over a variable-speed motor drive.

This blower delivers air to a duct and control valve within the building, as shown on Figure 45. To this duct is connected a 9-in.-diameter measuring section equipped with pitot tube and inclined manometer for measuring airflow in accordance with ASME and ASHVE standards. Beyond the measuring duct are the two electrostatic filters, connected in series and discharging into the shelter (Figure 46). The over-all length of the duct from the fan, and including the precipitators, is 25 ft. A type S power pack is shown on the stand with the manometer. All controls were located within the building.

Since the air-lock system was inoperative for these tests, it was necessary to install Chemical Corps anti-back-draft relief valves to discharge the air in excess of the normal building leakage. It has been determined by previous tests¹⁴ that the air leakage of this structure was approximately 200 cfm.

During the test, the ionizer voltage was 14,000 and the plate 6,000. Every effort was made to seal around high-tension external-casing bushings and between the filters to prevent leakage. The collector plates were sprayed with Type F adhesive in accordance with the manufacturer's recommendations.

Two simulated BW attacks were conducted on the building pressurized to 0.6 in. water at airflow rates of 800 and 1200 cfm, with the protective features, as described above, in operation. This work was completed by Camp Detrick personnel. Their comments and the results of these tests are recorded in Special Report No. 171. The pressure drop across the precipitrons at various airflows is given in Figure 47.

It is recommended that for practical purposes of maintenance and application of the adhesive, this type of precipitator be installed for vertical airflow. It is further recommended that any installation include prefilters to protect the electrostatic filters from overloading by larger dust particles.

RESULTS AND DISCUSSION

The scope of the tests and the results obtained were much more extensive than those of the original tests on the temporary protective shelter. A number of comparisons can be made and conclusions drawn.

Sealing

A selection of sealing materials suitable for various applications have been tested and found suitable for sealing requirements. The results obtained from these tests proved that strippable plastic cocoon material is the most satisfactory sealing agent, and can be applied by inexperienced personnel in the shortest time.

The tests indicated that almost any semipermanent or permanent type building, even of relatively large size can be sealed effectively. Sealing was not found necessary over surfaces or normal construction joints, but was required around loosely fitting windows, utility piping, and wiring outlets.

Pressurization

The results obtained from pressurization studies showed that under pressurization, the whole structure acts somewhat like a sieve or strainer and air is forced out through fissures and crevices not visible to the eye. The higher the pressurization, the higher the leakage. Even with no pressurization and with cracks and joints sealed, there is a considerable air change by leakage ventilation amounting to about one-half an air change per hour for normal frame construction.

This value depends on wind pressure and temperature difference. The leakage is sufficient to provide the necessary air for considerable personnel in a building closed for the short periods of an attack.

Optimum Pressurization

These tests were unique (former tests were confined to pressurization of 0.6 in.) and indicated that pressurization of considerably less than 0.6 in. of water would provide the desired protection with a saving in operating and fan and filtering equipment cost. The optimum pressure is probably about 0.1 in. unless future tests determine that a higher pressure is required for operation of the air locks.

Filter Frames and Collective Protectors

The Bureau of Yards and Docks pressurized filter plenum is difficult to construct, requires too much space, and is too heavy.

The filter frame developed by the Laboratory has these advantages: space, flexibility, and fabrication.

The Chemical Corps E-35 collective protector, delivering 5000 cfm at approximately 3.0 in. water pressure drop, equipped with a 7.5 hp, L.J. Wing Form 15A45 axial fan, proved satisfactory and preferable for the pressurization of the 50,000-cu ft test building. It afforded the desired protection under the simulated BW attacks. Some further minor developments and product design may be desirable for quantity production.

Decontamination Showers

A definite technique of showering, soaping, brush scrubbing, and rinsing has now been developed and proven effective. Suitable shower heads and spray patterns have been determined together with desirable water quantities, temperatures, pressures, and nozzle arrangements.

Generally a 4-minute shower from a single coarse spray head located at shoulder height in an angular position, and delivering a minimum of 3.5 gpm of water at 40 psi and 95 F is necessary, together with brush scrubbing and antiseptic soap.

Portable Air Locks and Showers

The prototype portable air lock with shower that was tested was found generally acceptable and effective. A number of minor construction

features have been recommended for change before distribution of plans for manufacture in quantities.

This equipment should be most effective in the program of starting new permanent type construction toward emergency conversion to personnel shelters for ABC defense and for the adaptation of existing structures for that purpose.

Electrostatic Precipitator

The electrostatic precipitator tested was the result of development initiated by the Naval Research Laboratory. It represents an improvement over commercial designs, with particular emphasis on the sealing of air passages which bypass the elements. Simulated BW tests were run at 800 and 1200 cfm and confirmed the fact that adequate protection against particulate matter or bacteria could be obtained with equipment of this type if velocities were not over 200 to 300 fpm.

CONCLUSIONS

A number of conclusions may be drawn as a result of these investigations and tests:

1. Framed structures not originally intended to be used as protective shelters can be converted for this use when sealed and pressurized. Sealing materials are available for the various applications and can be applied readily with unskilled help at low cost. Collective protector designs are available in various sizes up to 5000 cfm for supplying uncontaminated pressurized air. They are compact, lightweight, and flexible, for use singly or in batteries as the need demands.
2. Where pressurization of structures is to be accomplished by the use of separate filters and fans, the partition-type filter frame, using materials low on the critical list, has been developed to give negative leakage around the filter.
3. Considerably less air is needed for pressurization as the pressurization requirement is lowered: less air and lower pressurization mean a saving in power and equipment cost. Many installations using low ventilation rates and selected commercial filters can now be designed or converted to provide protection, for round-the-clock operation, against hazardous particulate matter. Since attacks are usually of short duration, alarm arrangements could be made to shut down and

close the ventilation system during an attack, or to bypass ventilation air through a gas and vapor adsorber. Such a system would be of particular advantage in critical government offices or military headquarters of a permanent nature, and would afford limited protection against a sneak chemical or biological attack by filtration through commercial filters currently on the market.

4. Pressurization in the order of 0.1 in. of water was effective in the protective shelter tested. This pressurization may be adequate for other applications.

5. Evaluation tests of the portable air lock indicate that a satisfactory design, subject to minor modifications, is ready for standardization and production. These air locks may be used for the ready conversion of buildings into protective shelters in the slanting construction program for ABC defense.

6. Results of the shower tests indicate that effective showering techniques and shower equipment for decontamination purposes have been developed.

7. The electrostatic precipitator as developed and tested for protection against solid and liquid particulates is effective. Although tests within the scope of this report were made only with a BW simulant, the statement made relative to particulate matter in general should hold. Liquid particulates of high vapor pressure may be expected to vaporize and pass through the precipitator. This device affords a means of filtering a relatively large quantity of air in a small cross-sectional area and gives commensurate performance to that of the Chemical Corps paper filter. It has low resistance and power requirements, and has an efficiency of 99.9 or more at velocities of 200 to 300 fpm, depending on the humidity and arrangement of the precipitators. It should, however, be used with a commercial prefilter to remove coarse material and lengthen the period between cleaning.

RECOMMENDATIONS

It is recommended that the program of slanting design and construction of new military buildings toward later conversion into personnel shelters be emphasized.

The prototype portable shower and air lock should be modified in accordance with suggestions contained herein, and the portable air locks or the plans for them made available to all interested activities.

It is recommended that approximately four air changes per minute be provided in the entrance air locks.

The Chemical Corps E-35 collective protector, capacity 5000 cfm, should be developed in a series of sizes and standardized for production with either motor or engine drive. A commercial prefilter of the coated impingement type, or equivalent, should be provided in the device. Prefilter studies should be made for this and related collective protectors.

Additional research to test the electrostatic precipitators with radioactive tracers, and to investigate and determine the most suitable prefilter for this equipment, is indicated.

An investigation should be made to determine the effectiveness of commercial impingement and self-charging electrostatic filters for use in ABC warfare. This should be done with a view to substituting a commercial, lower-efficiency filter for continuous use in lieu of an absolute paper filter or collective protector, either of which is suitable only for limited operation during periods of imminent biological attack.

Research relative to sealed, closed shelter occupancy and effects on subjects over periods should be undertaken to study various methods of oxygen supply, carbon-dioxide removal, and odor control.

Tests should be conducted on various other types of buildings to prove or disprove that pressurization to 0.1 in. of water effective in the building tested, is valid.

Subsequent editions of the U.S. Navy Biological Warfare Defense Manual, NAVDOCKS TP-PL-4⁵, and similar publications, should include the recommendations on sealing, pressurization, and showering.

REFERENCES

1. Armour and Company, Industrial Soap Division, Product Information Bulletin 8-A, Antiseptic Soap for Hospital Use, 5 November 1950.
2. Army Chemical Center, Protective Division, Technical Command, TCIR 625 (SECRET) Evaluation of Air Purification System of "T" Building, Mound Laboratory, by A. A. Cooke, 5 March 1951.
3. Bureau of Standards, Special Report to the American Society of Heating and Ventilating Engineers, Appendix II, Summary of Results on Infiltration Measurement, June 1952.
4. Bureau of Yards and Docks Drawing No. 476644, Building Pressurization Studies - Filter Plenum Details, 20 December 1949.
5. Bureau of Yards and Docks, NAVDOCKS TP-PL-4 (RESTRICTED), U.S. Navy Biological Warfare Defense, 1 June 1952.
6. Bureau of Yards and Docks Drawing Nos. 566814 and 566815, Portable Air Lock for First Class Shelter, Preliminary, 23 April 1952.
7. Bureau of Yards and Docks, Drawings 575412 and 575413, Portable Air Lock with Shower, Preliminary, 8 August 1952.
8. Chief, Bureau of Yards and Docks (F. F. Kravath), Confidential letter P-312B:vhi/A16-11, serial YD 8689, 5 November 1952, "Collective Protector, 5000 CFM, EMD # -35" to Officer in Charge, U. S. Naval Civil Engineering Research and Evaluation Laboratory, enclosures (1) Data, (2) Blueprints from ACC.
9. Chemical Corps Biological Laboratories, Physical Defense Div., Special Report No. 171, BW Evaluation of Pressurized Building No. 7-635 at the Naval Civil Engineering Laboratory (1952), in publication.
10. Dick, J. B., "Measurement of Ventilation Using Tracer Gas Technique," Heating, Piping and Air Conditioning, vol. 22, May 1950, p. 131.
11. Director, NRL, Confidential letter C-3240-129/50 ahds, 19 December 1950, "NRL-Modified Electrostatic Precipitators, Performance of" to Chief, Bureau of Ships (Code 688), enclosure (1), "Performance of NRL-Modified Electrostatic Precipitators" by George H. Fielding and Edward L. Jones.

12. Heating, Ventilating and Air Conditioning Guide, 1952, Chap. 10, "Infiltration and Ventilation," American Society of Heating and Ventilating Engineers, 1952, p. 220.
13. Hollingshead, R.M., Corporation, Report No. 5041, Hollingshead Cocoon, Procedure for Interior Vapor Sealing of Buildings Fabricated of Corrugated Aluminum Alloy Sheet, Wood, or Plywood, Revised 15 April 1952.
14. NAVCERELAB Technical Report No. R-002 (RESTRICTED), Temporary Protective Shelter - Construction and Performance Tests, by E.P. Donoghue, E.H. Moser, and W. Viessman, 1 August 1950.
15. NAVCERELAB Technical Memorandum No. M-035, Building Protection Against Biological Warfare Attack, by Warren Viessman and E.N. Hellberg, 1 February 1952.
16. NAVCERELAB Drawings D-52-4, D-52-5, and D-52-6, Pressurized Filter Frame, 22 April 1952.
17. NAVCERELAB Technical Memorandum M-017, Personnel Shelters in Modern Warfare, by W. Viessman, 1 July 1951, Figure 25.
18. Trion, Inc. (RESTRICTED) Report on High Efficiency-High Velocity Electrostatic Precipitator, Navy Contract NObS-54753, Index NS-130-003, Codes 324 and 549, by George F. Landgraf, 12 September 1951.
19. University of Minnesota Engineering Experiment Station Summary Report No. 1, Pressurization of Buildings, Contract NOy-22273, by C.E. Lund, W.T. Peterson, and T.F. Irvine, Jr., 1 October 1951.

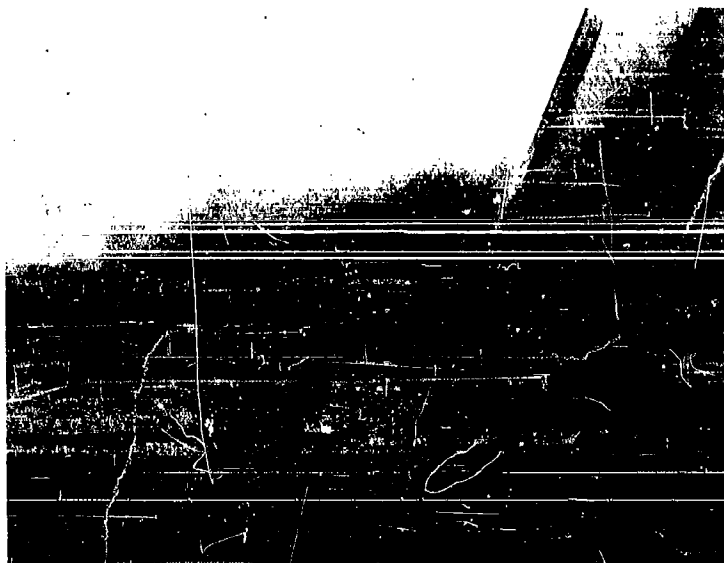

Figure 2. Window crack sealed with cocoon.



Figure 1. Spraying window crack with cocoon material.

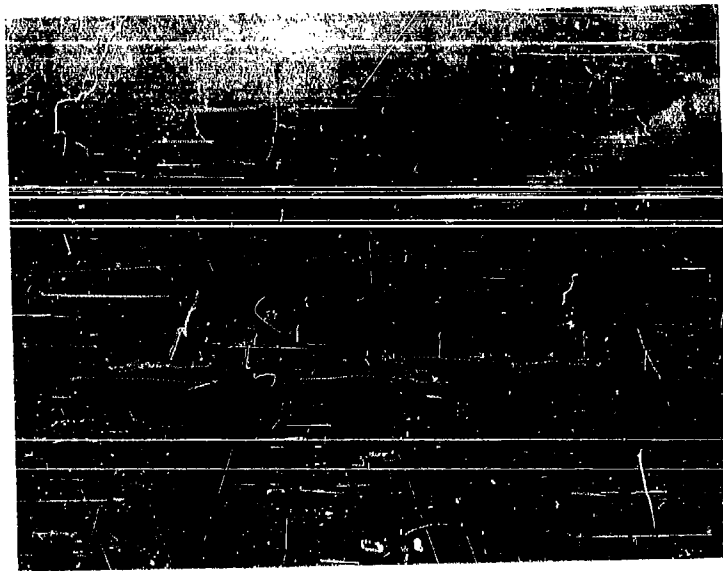

Figure 3. Sealing around pipes passing through celotex ceiling.

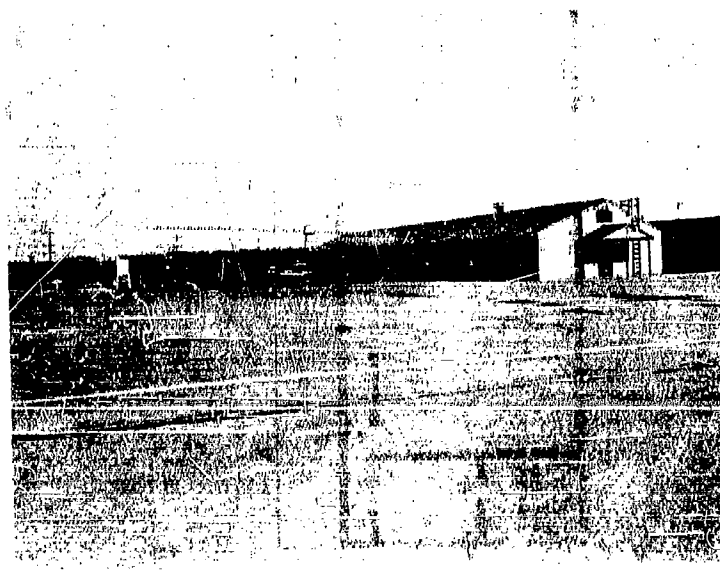
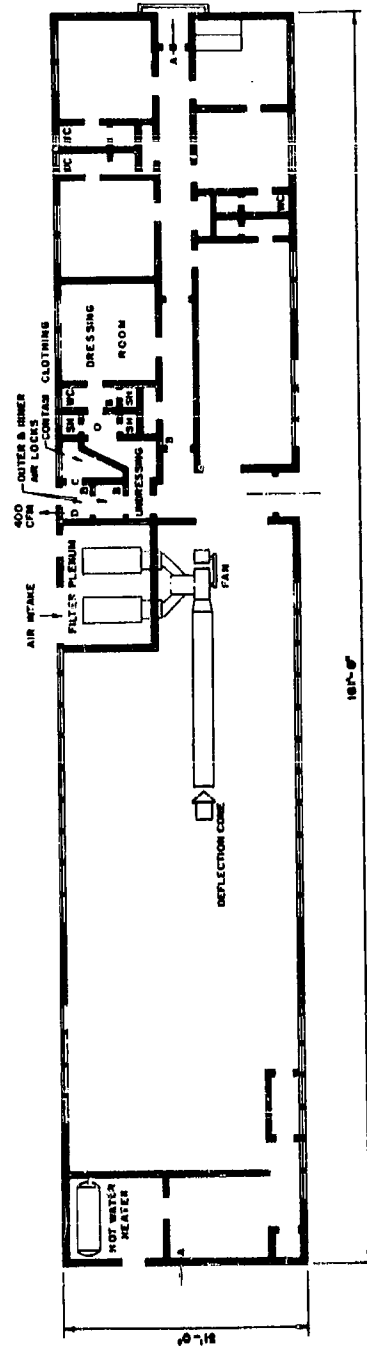

Figure 4. General appearance of the test building.



FLOOR PLAN

LEGEND

- A PRESSURE RELIEF VALVE (ANTI-BACKDRAFT)
- B AIR REGULATOR (RUBE TYPE)
- C PASS DOOR FOR CLOTHING
- D NON-RETURN FLOW VALVE
- SH SHOWER
- WC WATER CLOSET
- O SHOWER VENT-200 CFM

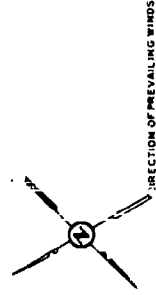

PRESSURIZED BUILDING



Figure 6. Sliding type window construction.

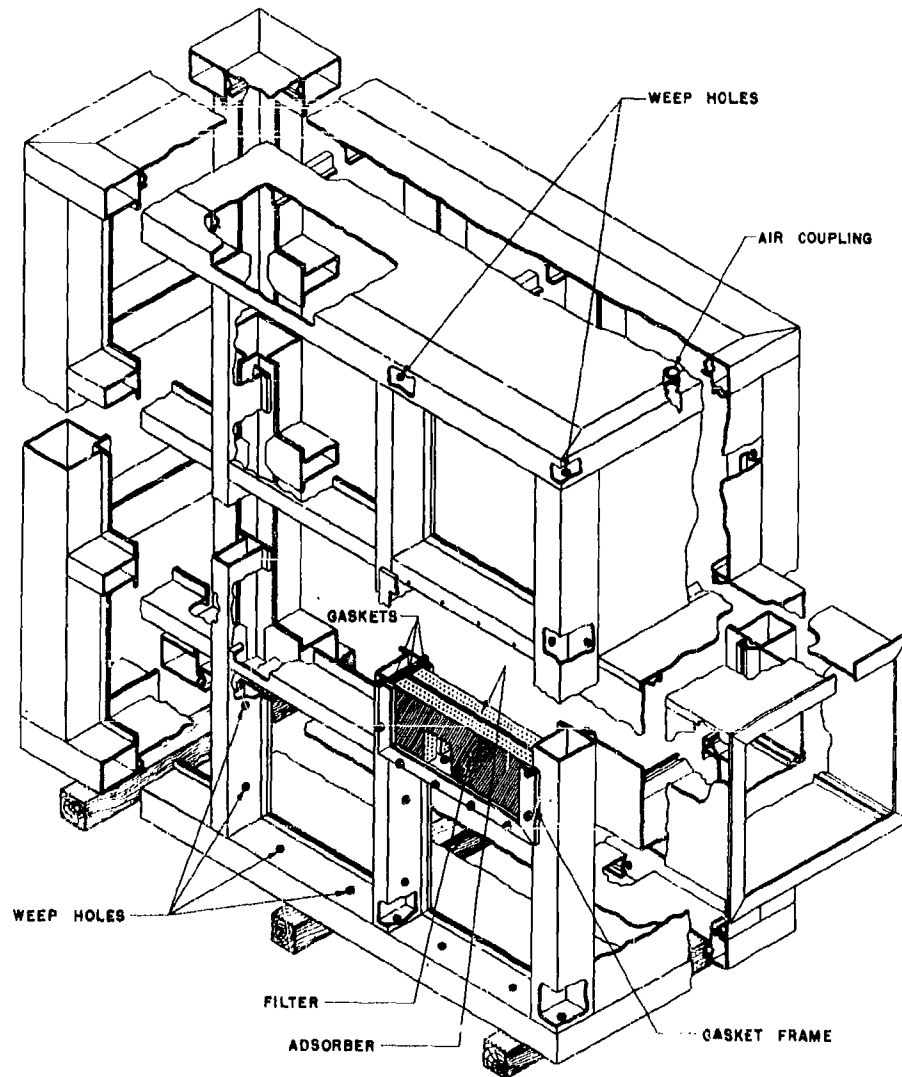

Figure 7. Isometric view of pressurized filter plenum.

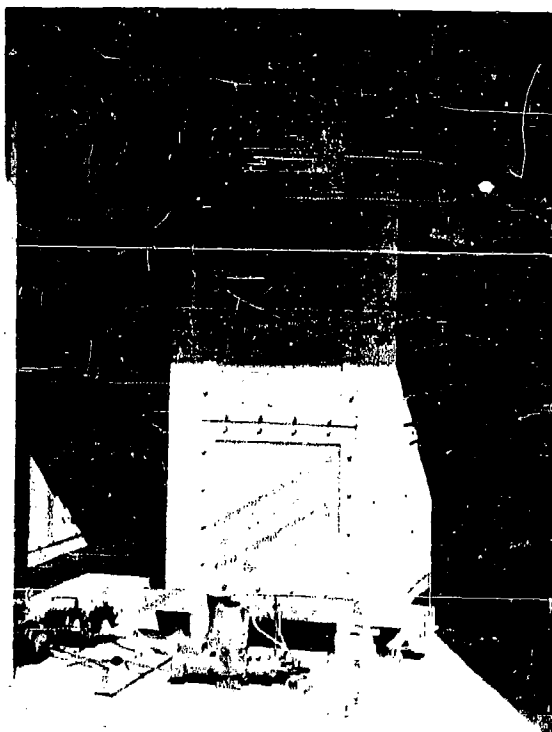

Figure 8. Pressurized filter plenum in place.

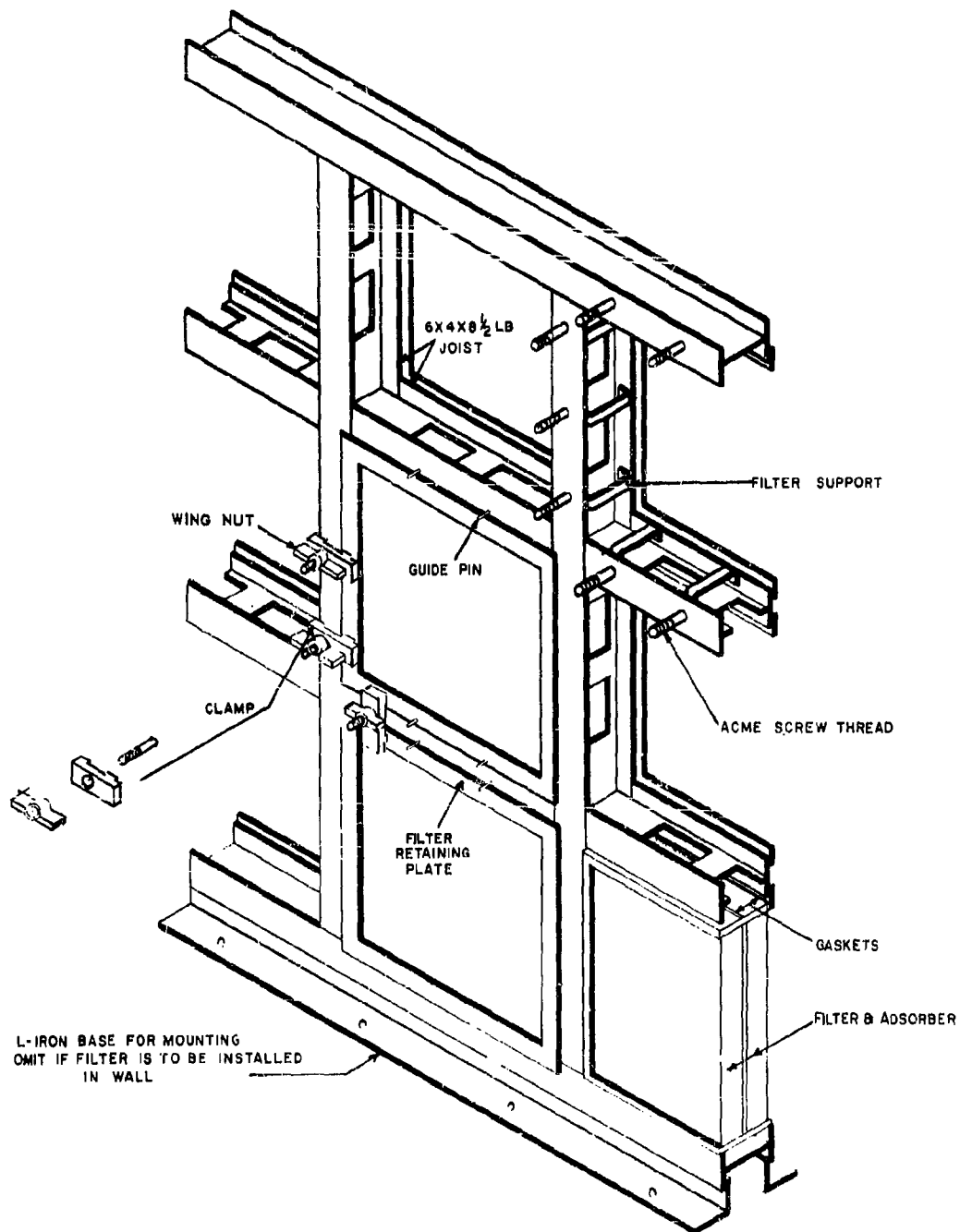

Figure 9. Isometric view of unit pressurized filter frame.



Figure 10. Construction of unit type pressurized filter frame.

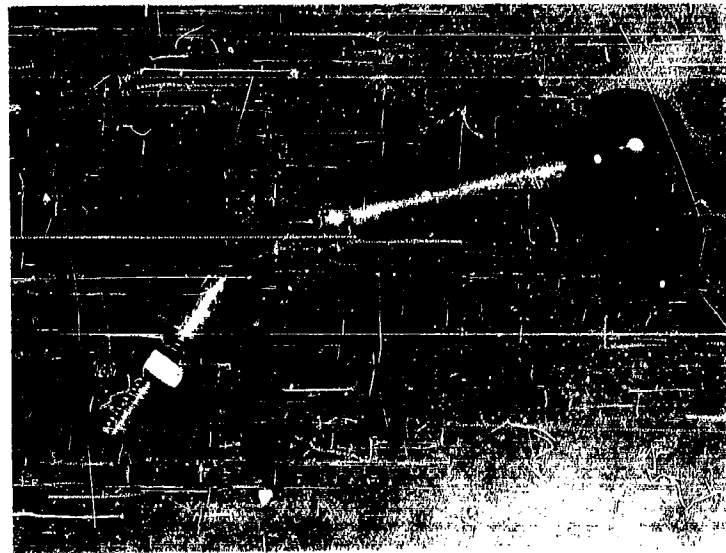

Figure 11. Quick acting cam and lever filter-retaining device.

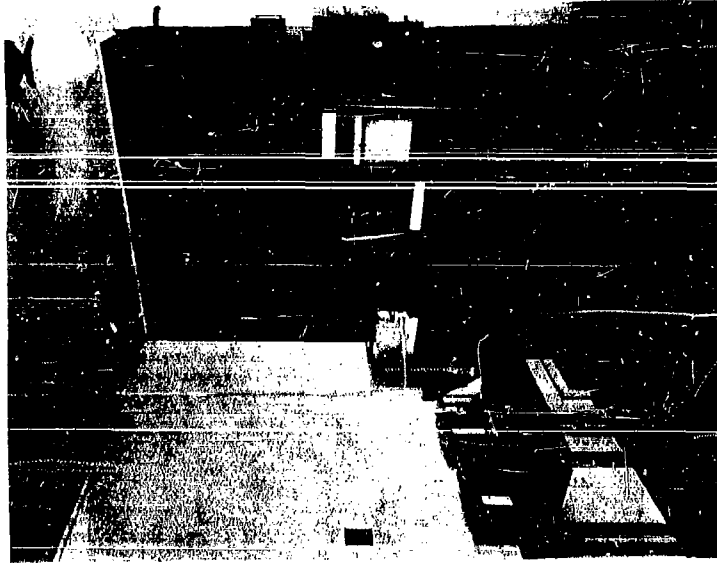

Figure 13. Weather instrumentation installed within the test building.

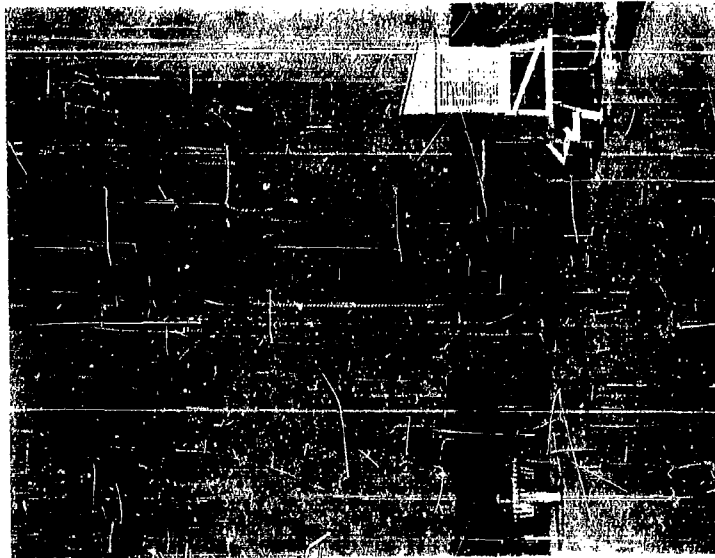

Figure 12. Weather instrumentation installed adjacent to test building.

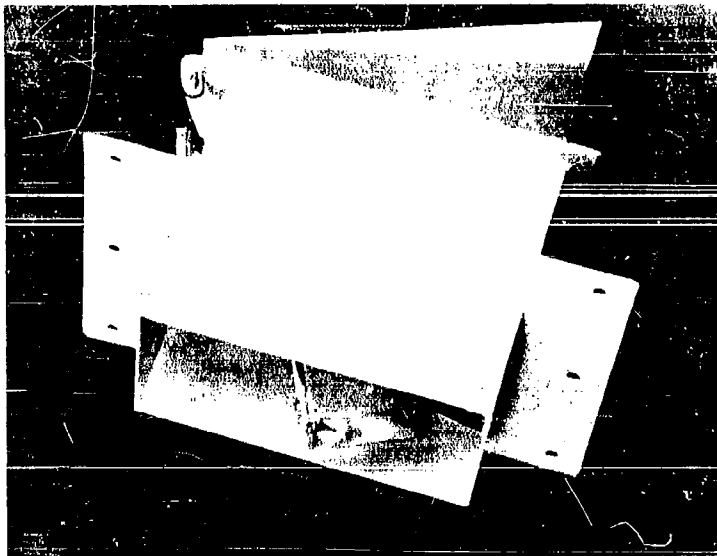

Figure 15. Air-lock exhaust valve.

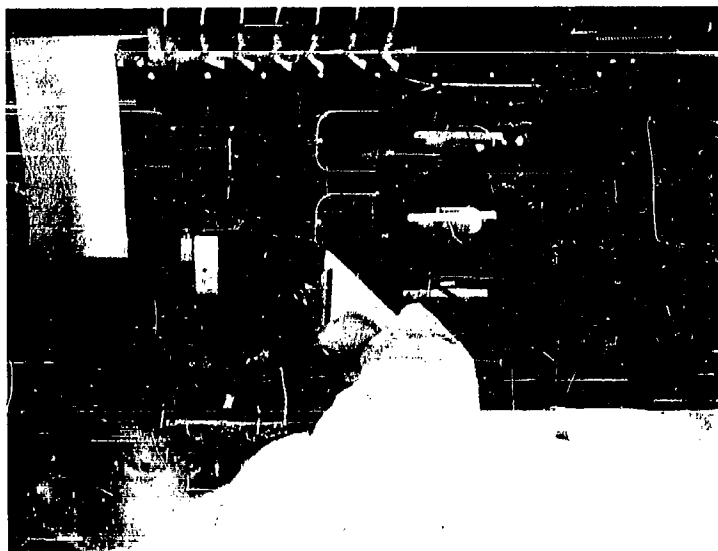

Figure 14. Cambridge helium analyzer.

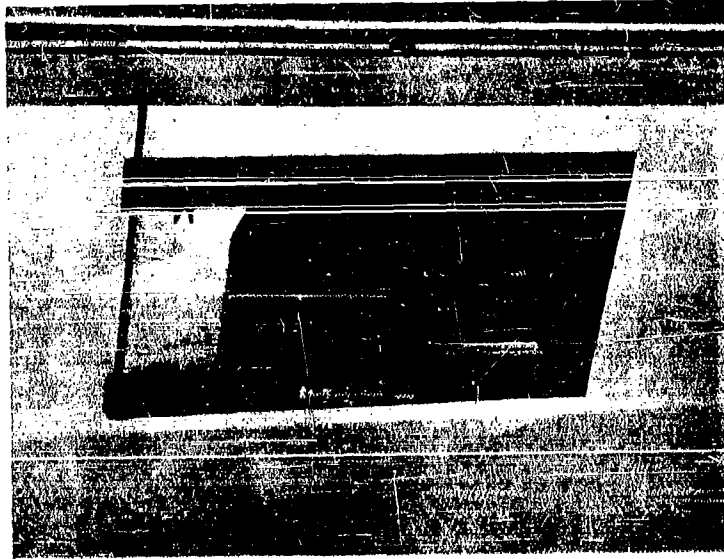

Figure 17. Air-lock pressure- and flow-regulator valve.

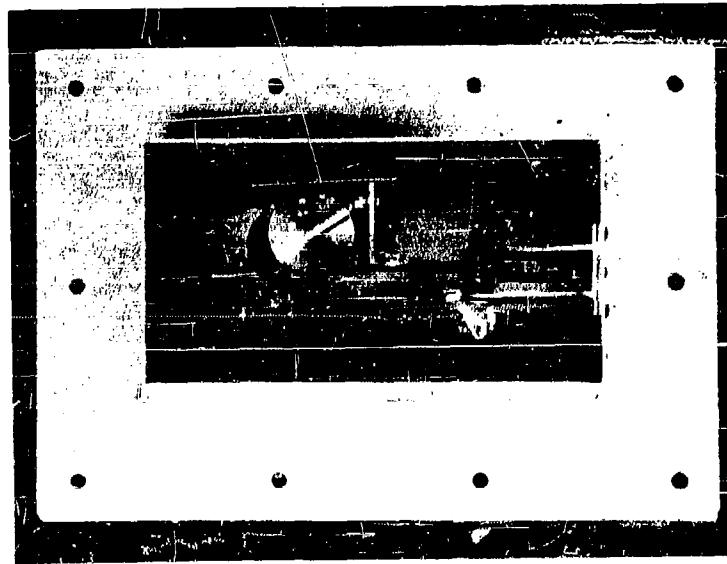

Figure 16. Interior of air-lock exhaust valve.

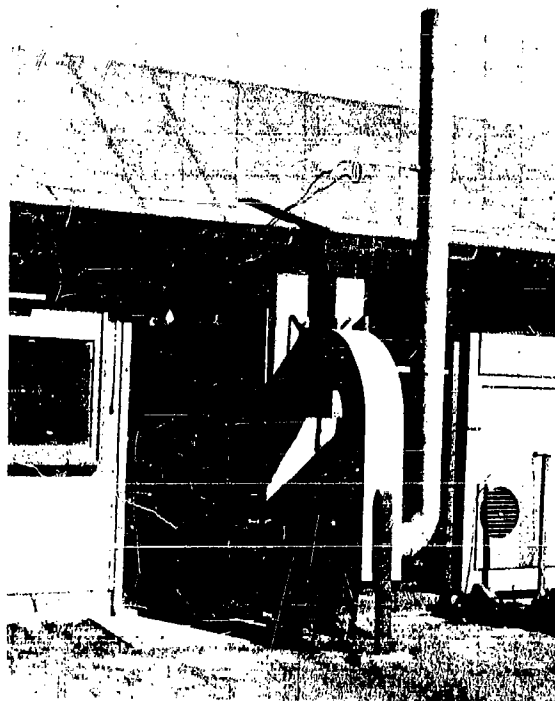

Figure 18. Entrance to outer air-lock and flow-measurement duct of air-lock exhaust.

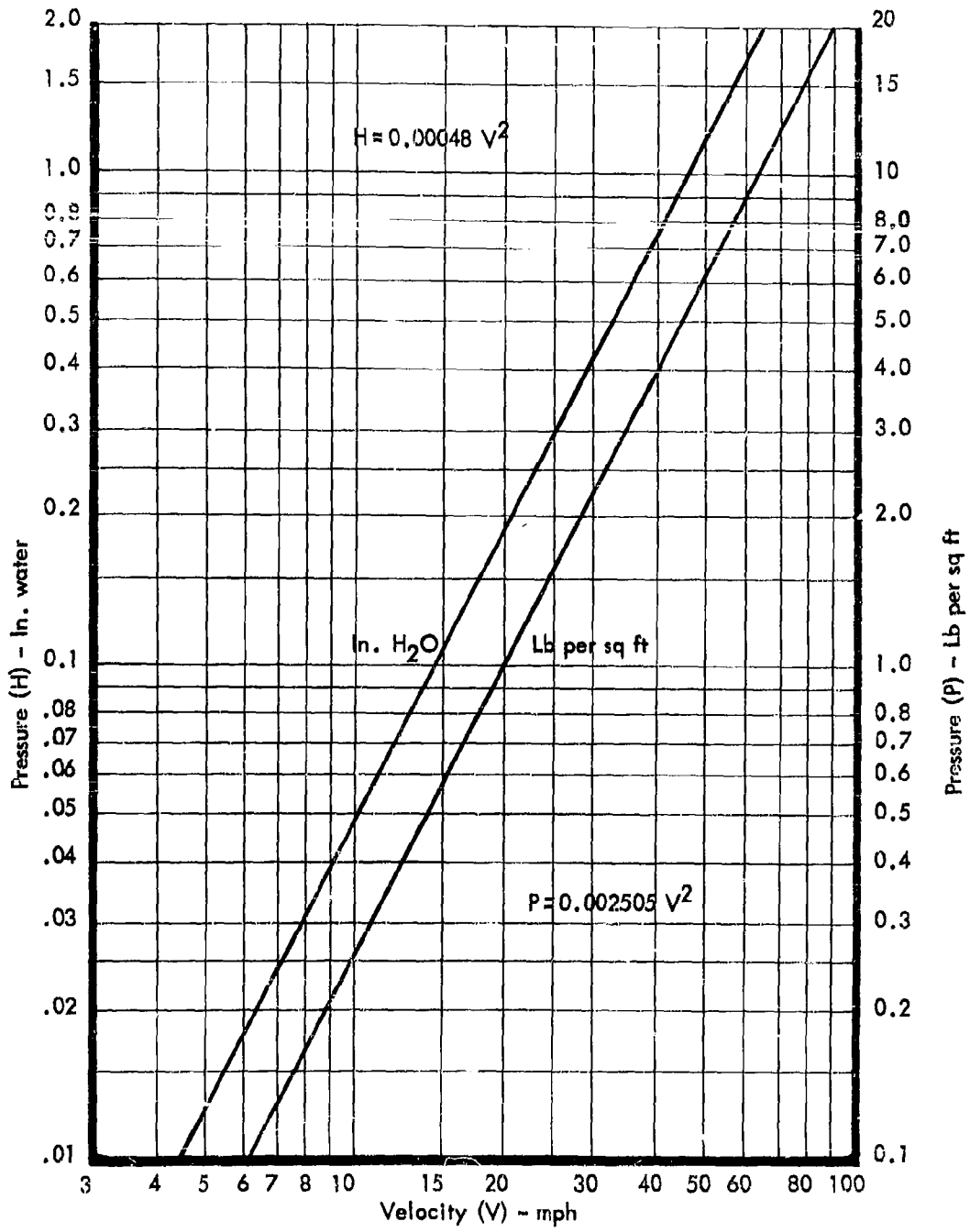

Figure 19. Wind pressure chart.

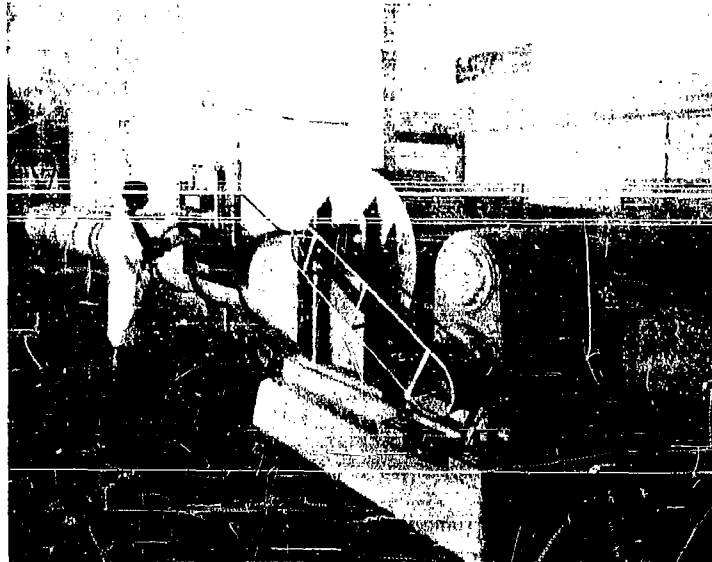

Figure 20. Pressurization fan.

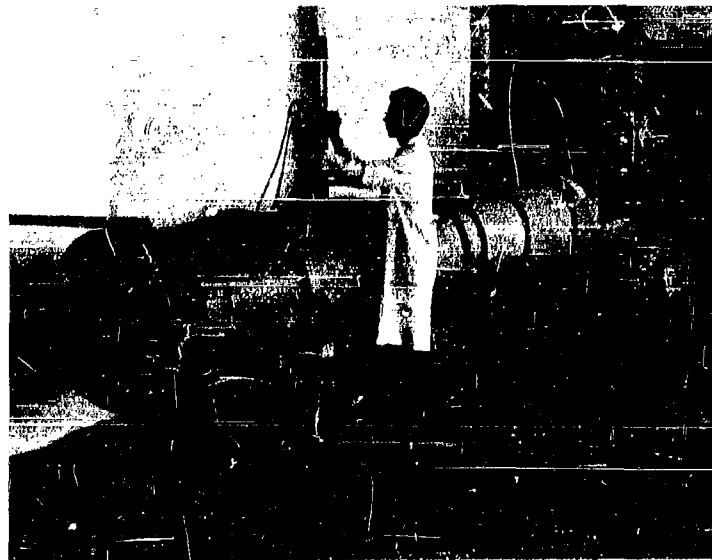

Figure 21. Pressurization airflow-measuring duct.

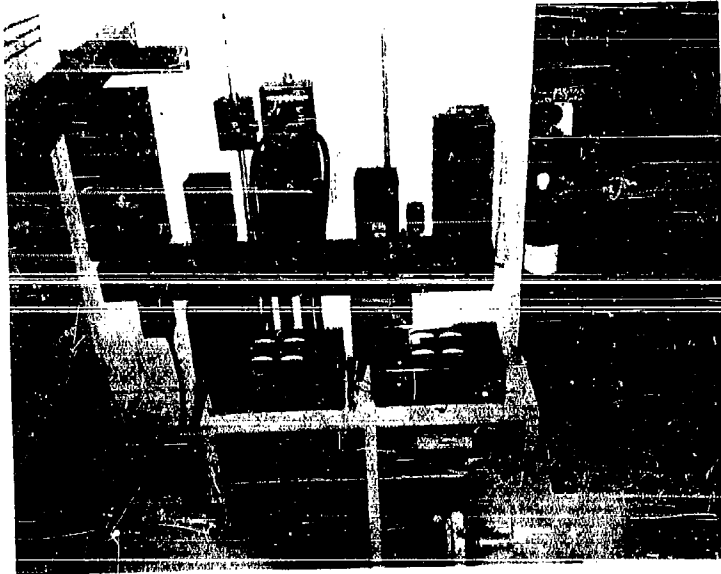

Figure 22. Instrumentation for the determination of electrical power input to pressurization fan motor.



Figure 23. Inclined manometers and valved manifold for measuring pressurization.

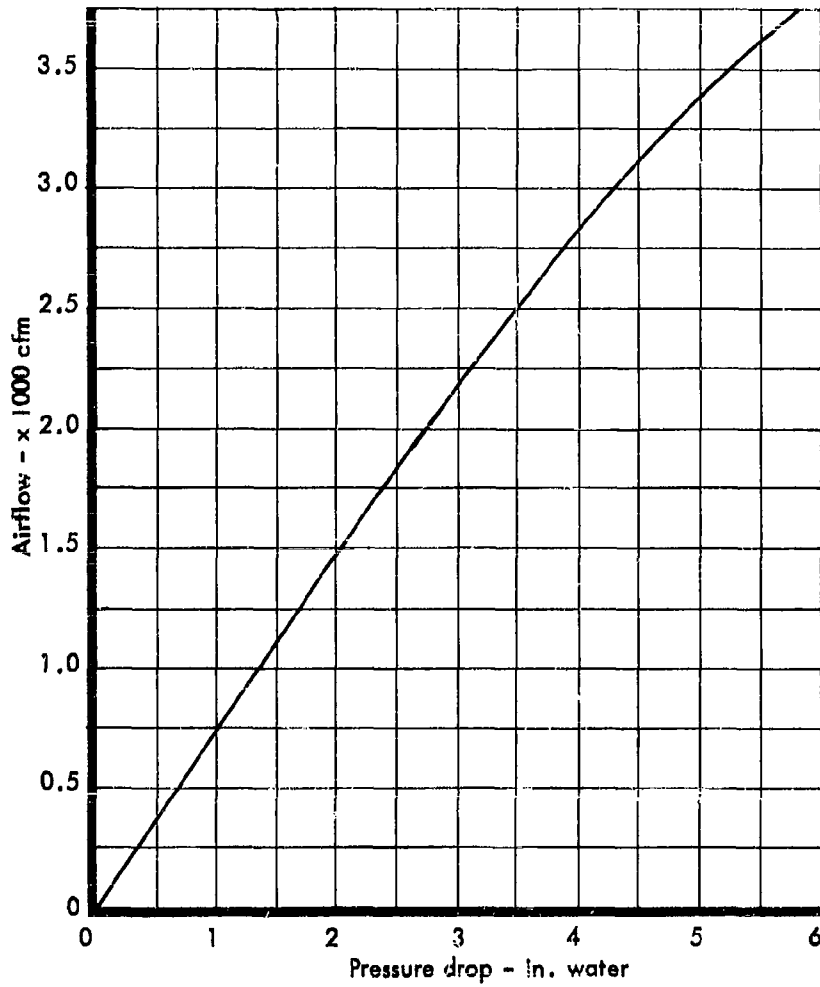

Figure 24. Resistance to airflow of 21 filters and adsorbers in plenum.

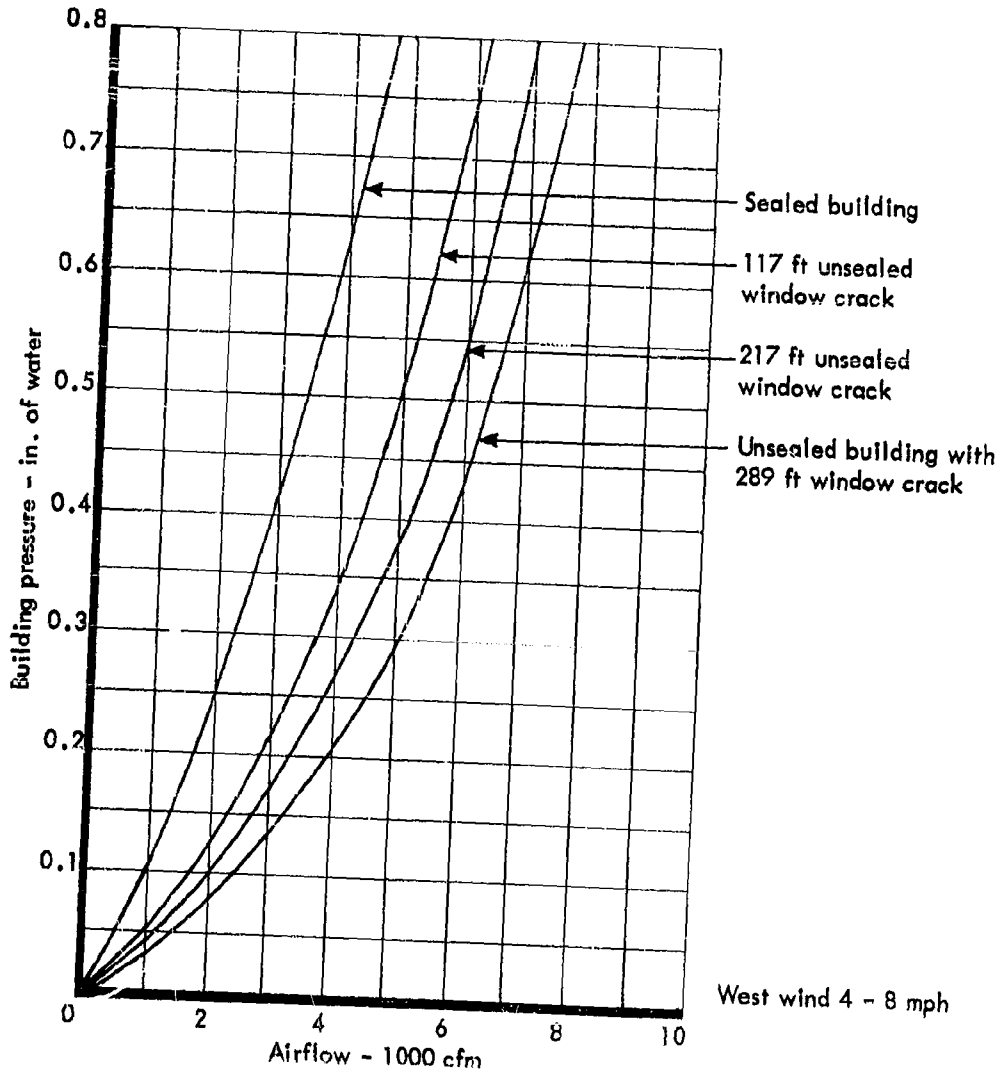

Figure 25. Building-pressurization characteristics.

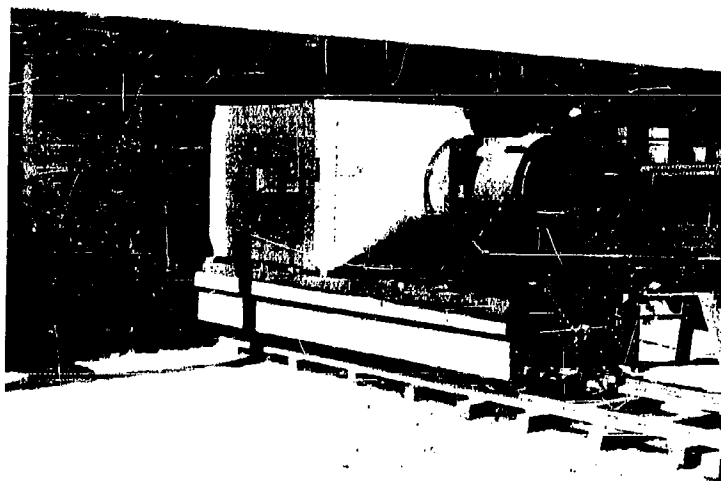

Figure 26. E-35 collective protector.

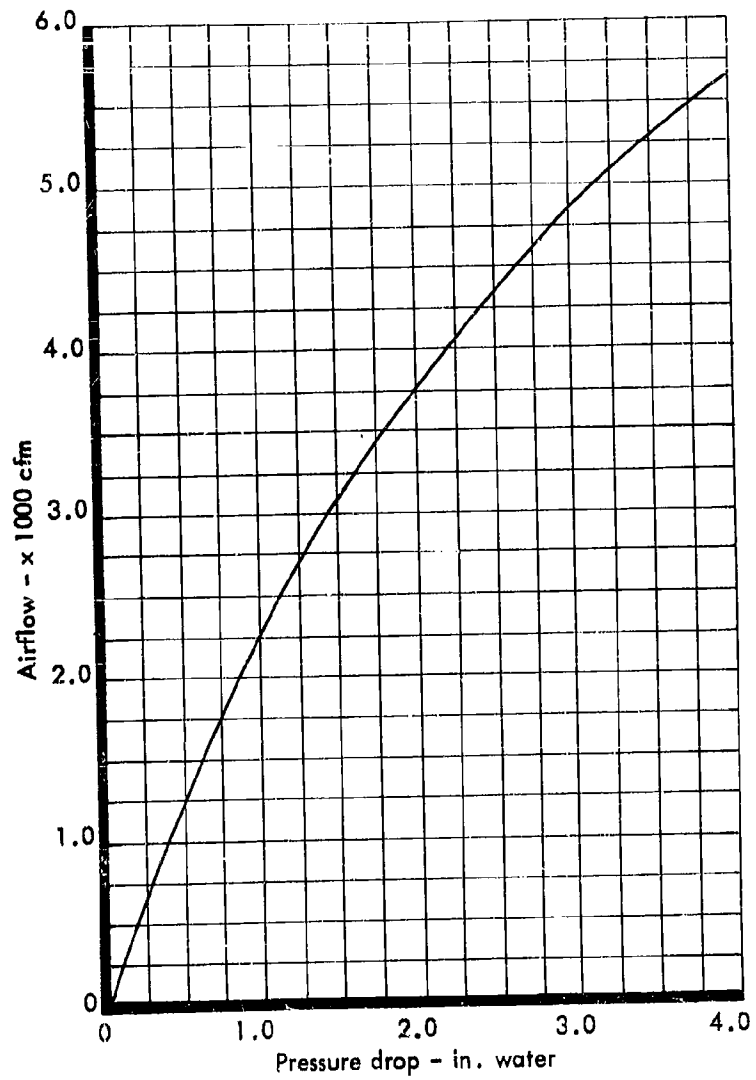

Figure 27. Resistance to airflow of E-35 collective protector.

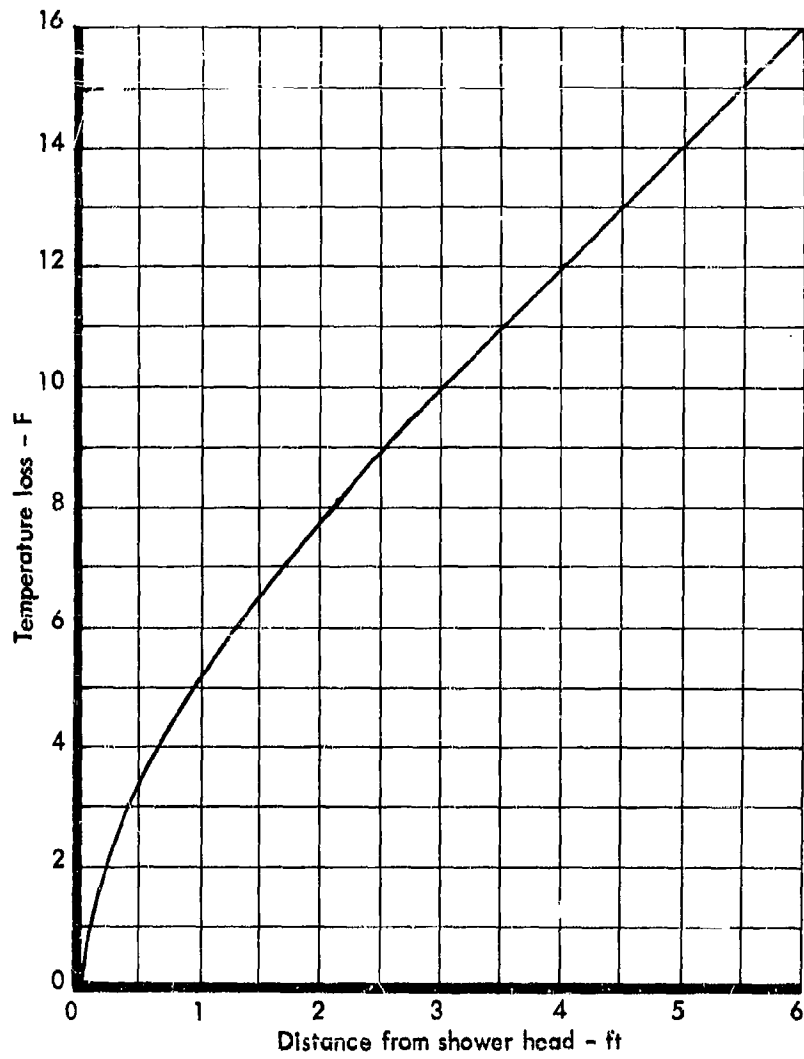

Figure 28. Approximate shower-spray water-temperature-loss from head.

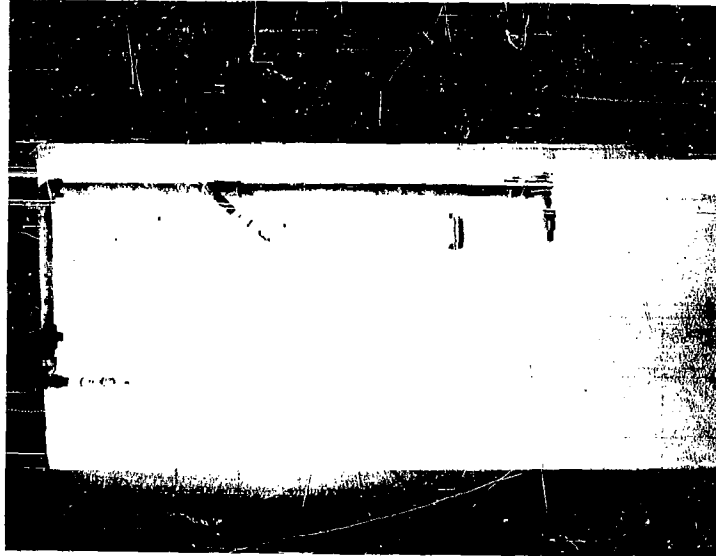

Figure 30. Shower head arrangements used during tests.

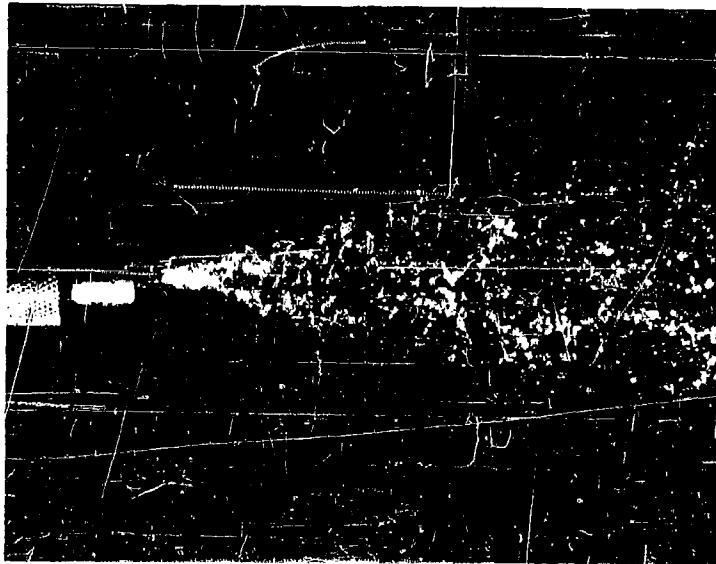

Figure 29. Coarse spray from shower head.

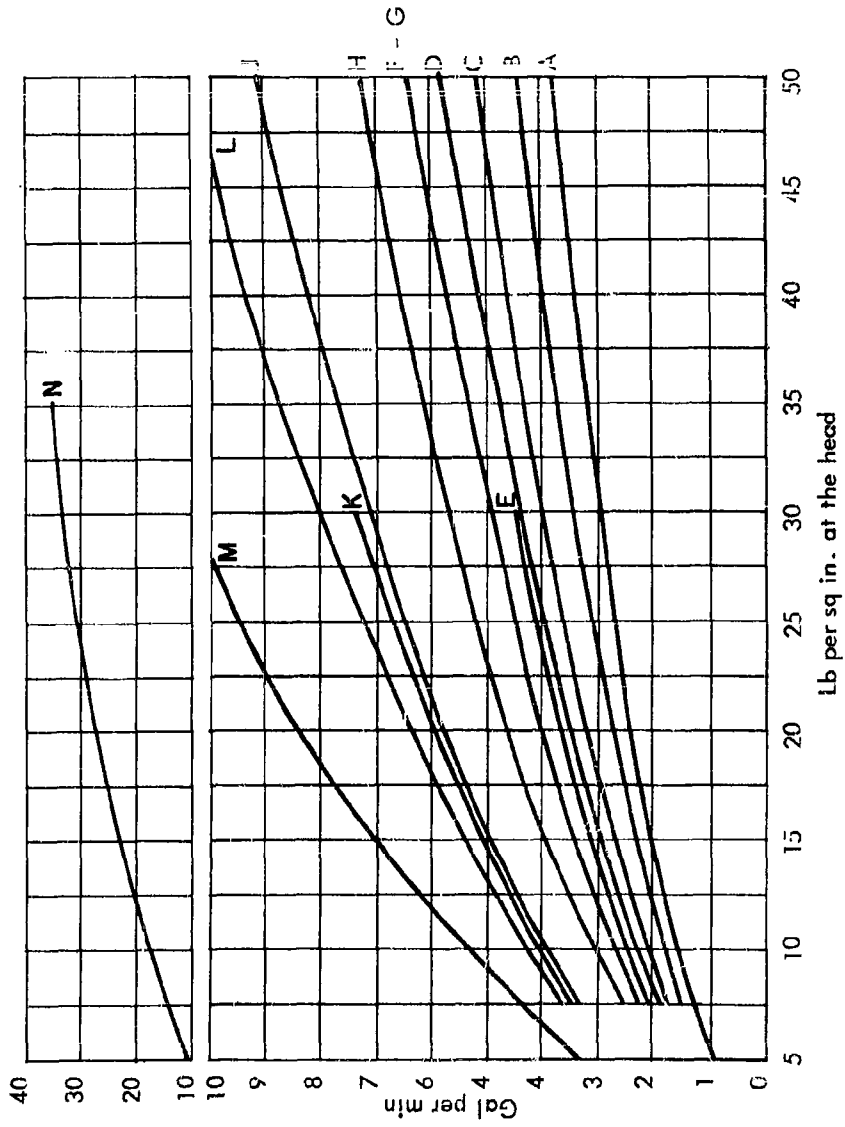

Figure 31. Pressure-flow characteristics of various shower heads.

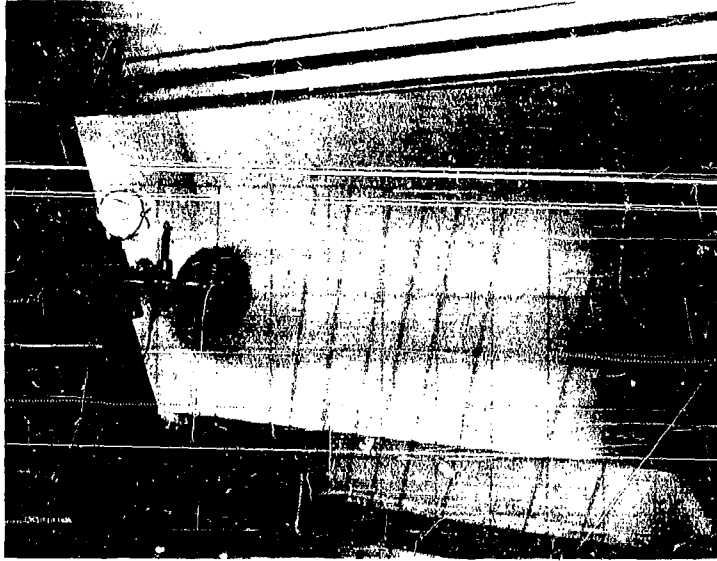

Figure 33. Speakman "Emergency" shower head and spray.

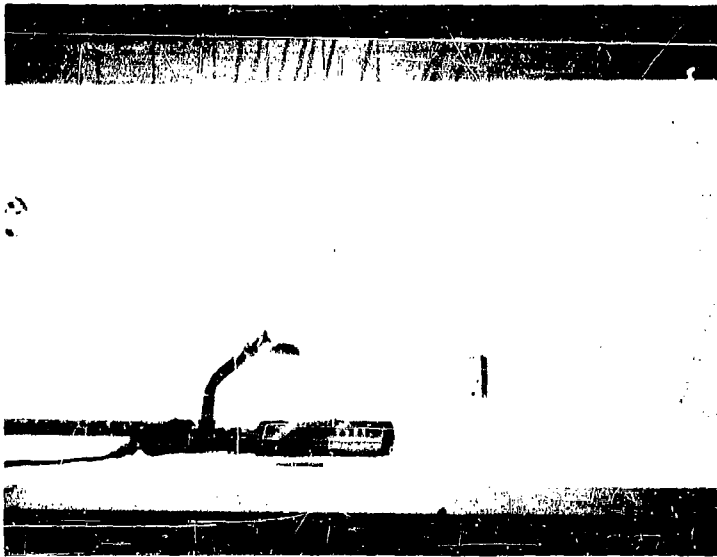

Figure 32. Price-Pfister "Perfect Spray" shower head.



Figure 35. Logan Standard "Wizard" shower head and spray.

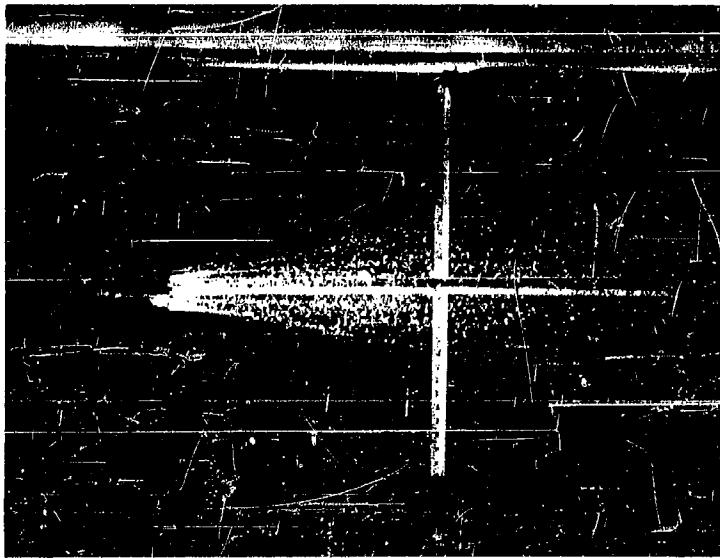

Figure 34. Speakman "Airstream" shower head and spray.

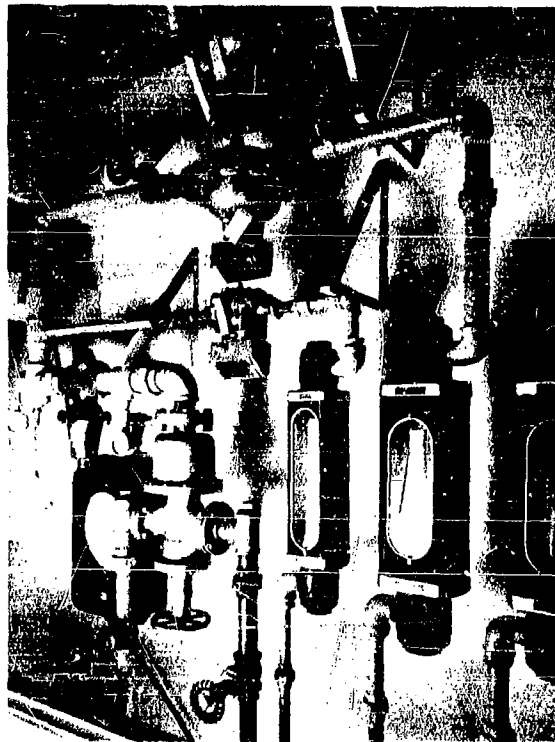
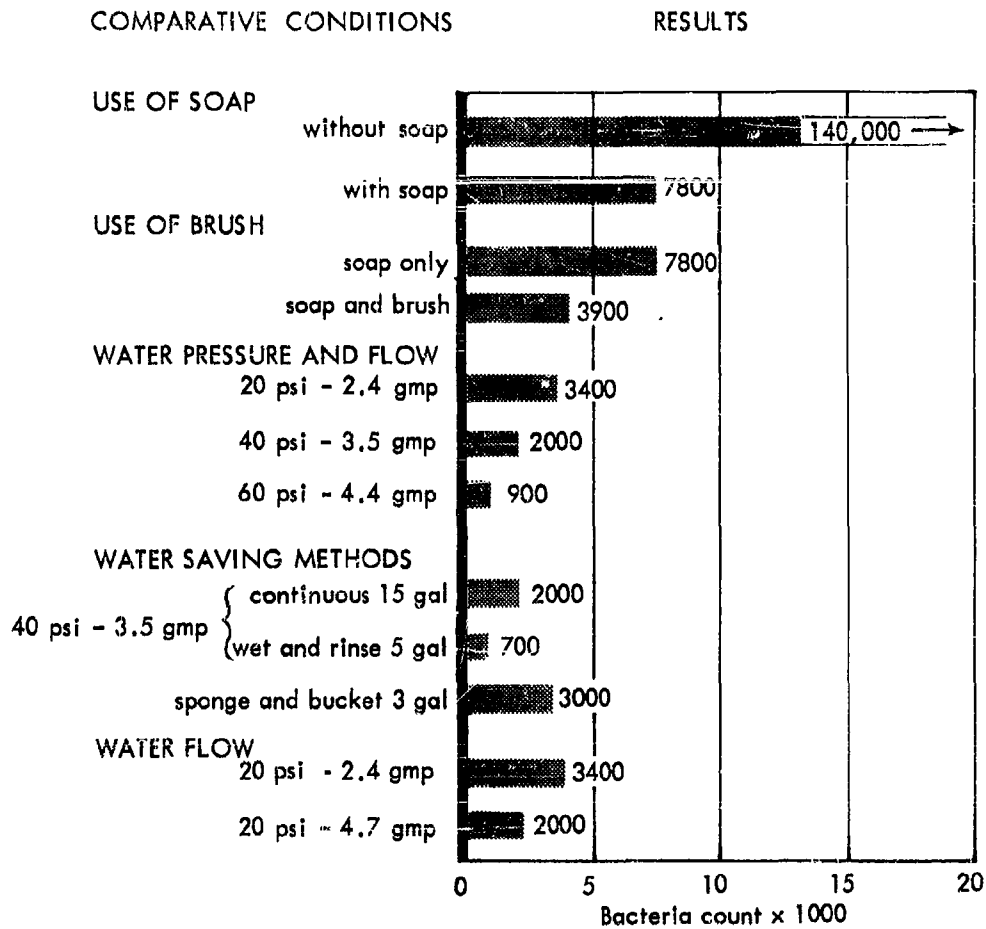

Figure 36. Instrumentation used in shower tests.



Bacteria count is sum of average residual count on contaminated spot and average of count increase on three uncontaminated areas, each 2 sq in., before toweling. Initial contamination - 300,000 to 500,000 bacteria per 2 sq in.

Figure 37. Evaluation of shower techniques.

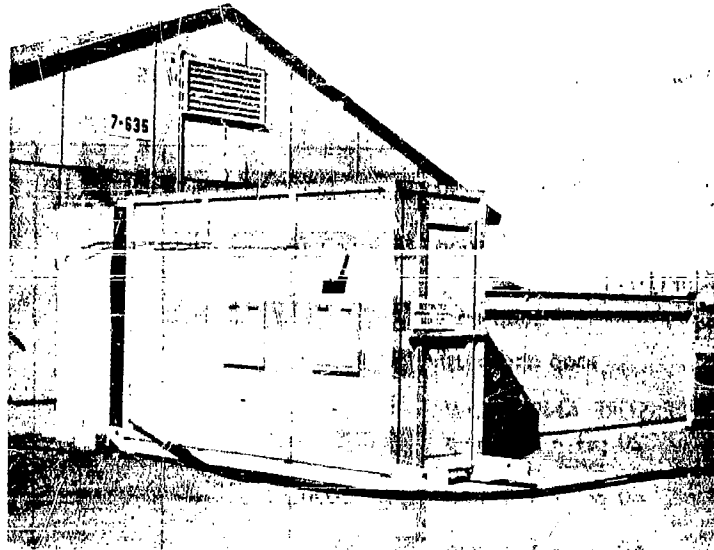

Figure 38. Portable air lock and shower connected to test building.



Figure 39. Portable air lock from shower end, showing canvas connection to building.

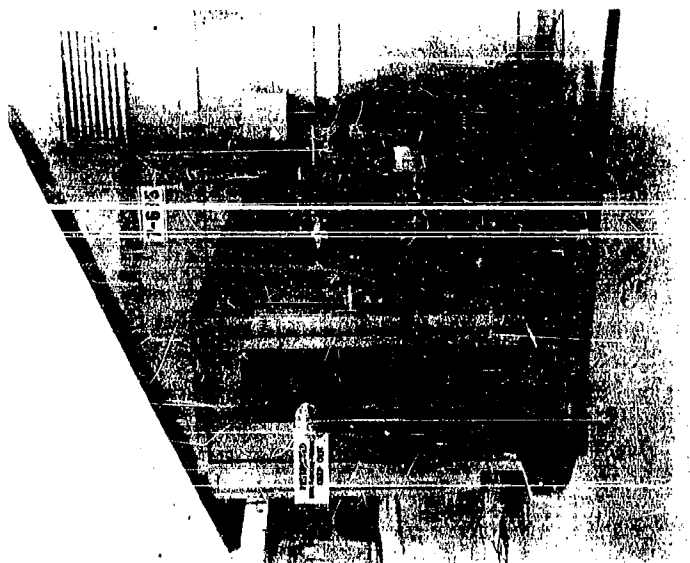

Figure 41. Portable air lock under test.

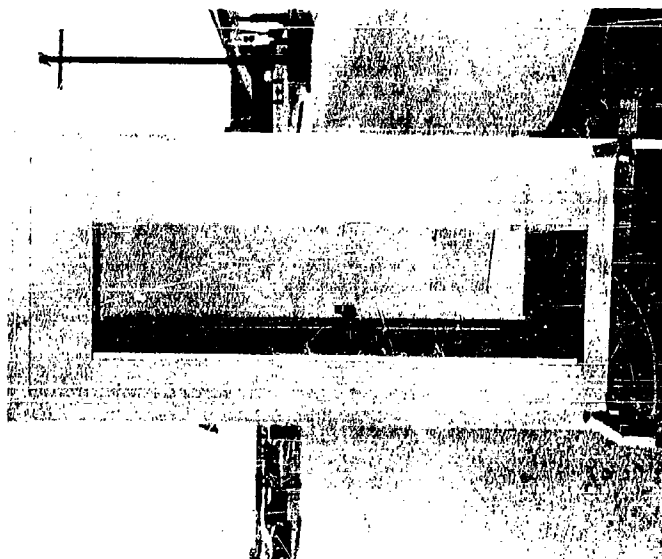

Figure 40. Portable air lock from outer air lock end.

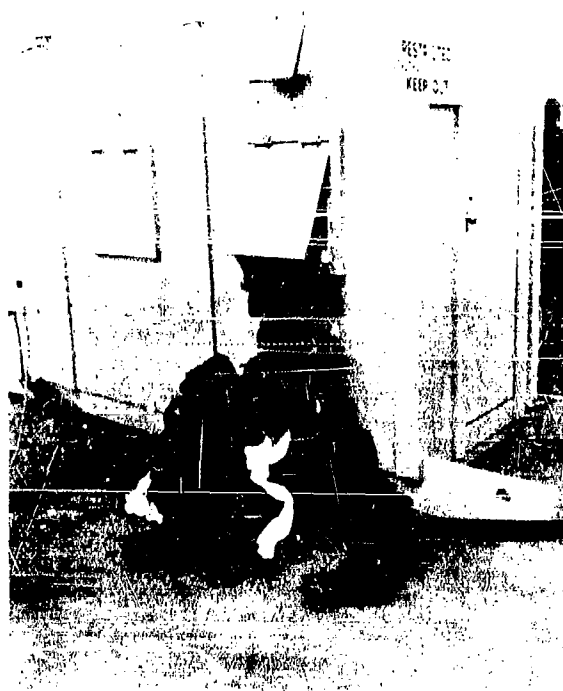

Figure 42. Portable air lock in use during test, showing discarded contaminated clothing.

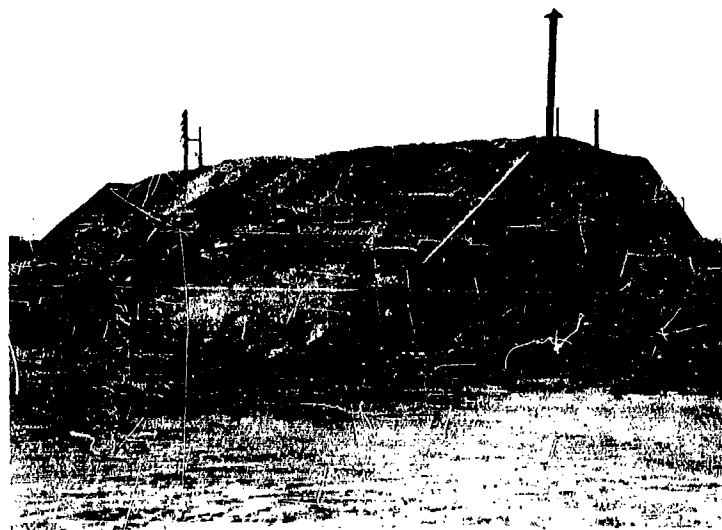

Figure 43. Temporary protective shelter equipped with electrostatic precipitator.

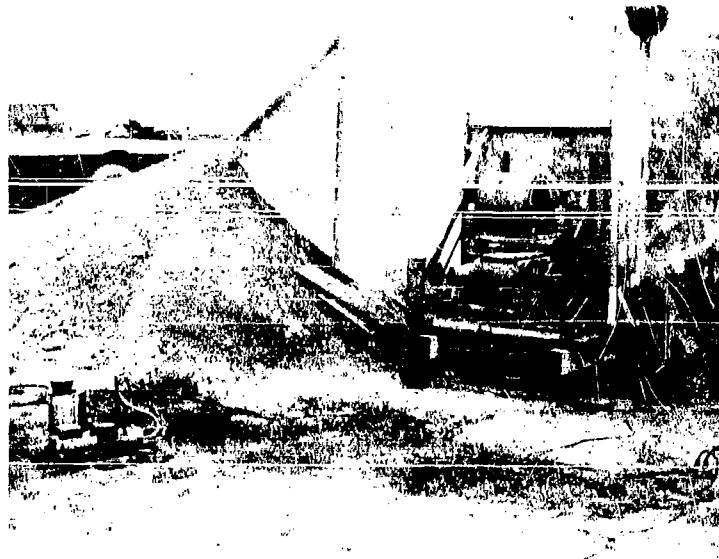

Figure 44. Air intake fan mounted on temporary protective shelter.

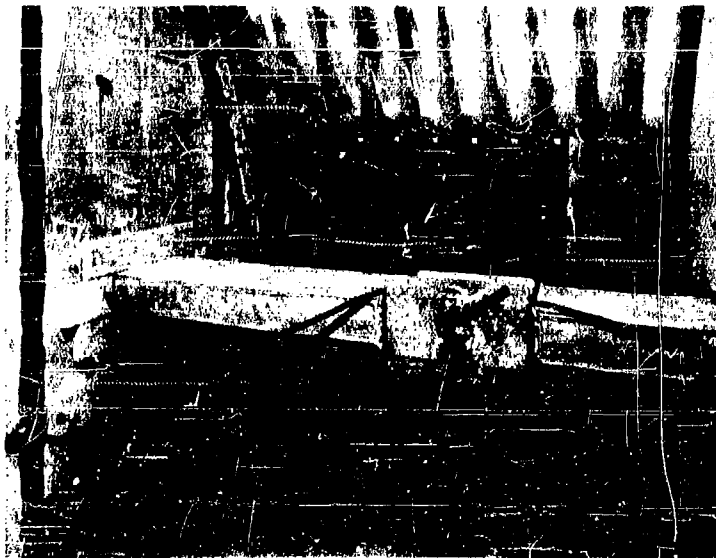

Figure 45. Air duct and flow control valve in temporary protective shelter.

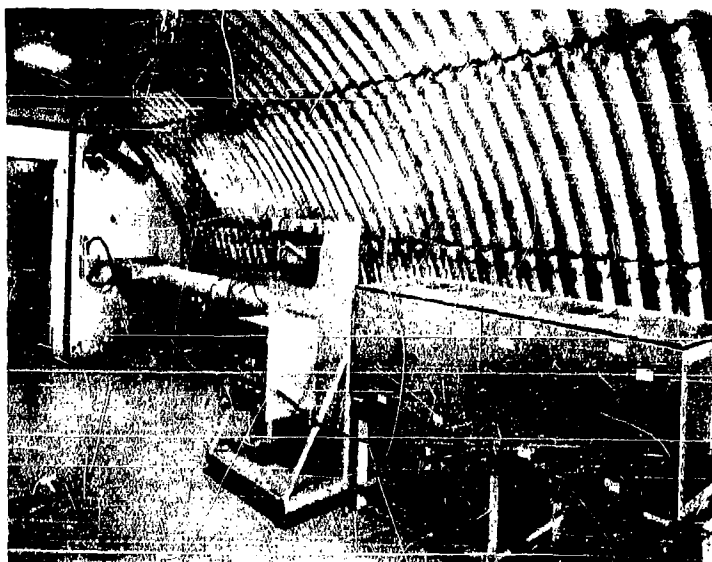

Figure 46. Electrostatic precipitators installed in temporary protective shelter for test.

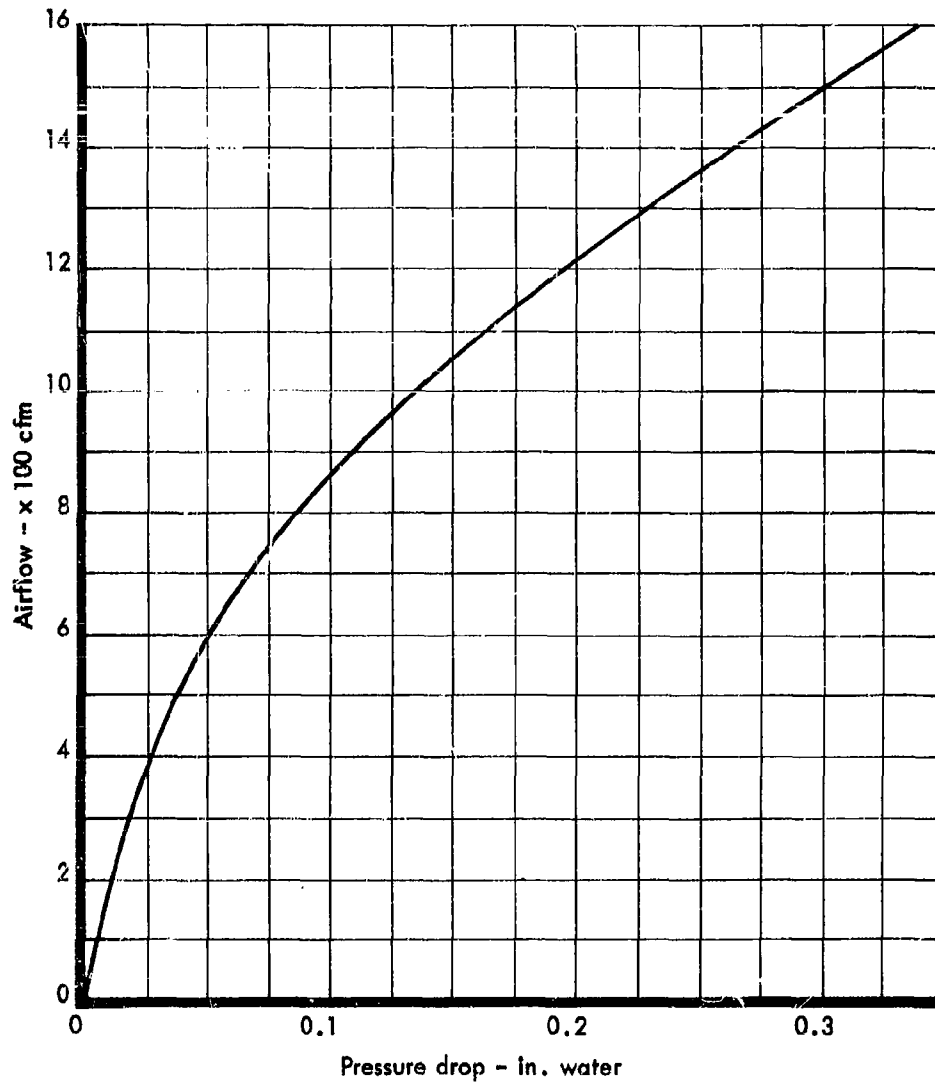

Figure 47. Resistance to airflow of two electrostatic precipitators.

AD 726188

Armed Services Technical Information Agency

Reproduced by
DOCUMENT SERVICE CENTER
KNOTT BUILDING, DAYTON, 2, OHIO

Because of our limited supply, you are requested to
RETURN THIS COPY WHEN IT HAS SERVED YOUR PURPOSE
so that it may be made available to other requesters.
Your cooperation will be appreciated.

NOTICE: WHEN GOVERNMENT OR OTHER DRAWINGS, SPECIFICATIONS OR OTHER DATA ARE USED FOR ANY PURPOSE OTHER THAN IN CONNECTION WITH A GOVERNMENT PROCUREMENT OPERATION, THE U. S. GOVERNMENT THEREBY INCURS NO RESPONSIBILITY, NOR ANY OBLIGATION WHATSOEVER; AND THE FACT THAT THE GOVERNMENT MAY HAVE FORMULATED, FURNISHED, OR IN ANY WAY SUPPLIED THE SAID DRAWINGS, SPECIFICATIONS, OR OTHER DATA IS NOT TO BE REGARDED BY IMPLICATION OR OTHERWISE AS IN ANY MANNER LICENSING THE HOLDER OR ANY OTHER PERSON OR CORPORATION, OR CONVEYING ANY RIGHTS OR PERMISSION TO MANUFACTURE, USE OR SELL ANY PATENTED INVENTION THAT MAY IN ANY WAY BE RELATED THERE TO.

UNCLASSIFIED