

UNCLASSIFIED

| | |
|--|---|
| AD NUMBER | |
| AD092488 | |
| CLASSIFICATION CHANGES | |
| TO: | unclassified |
| FROM: | confidential |
| LIMITATION CHANGES | |
| TO: | Approved for public release, distribution unlimited |
| FROM: | Distribution authorized to U.S. Gov't. agencies and their contractors; Administrative/Operational Use; 22 DEC 1955. Other requests shall be referred to Navy Ordnance Systems Command, Washington, DC 20350. |
| AUTHORITY | |
| 30 Jun 1967, Group-4, DoDD 5200.10; USNSWC ltr dtd 4 Dec 1974 | |

THIS PAGE IS UNCLASSIFIED

CONFIDENTIAL

**A
D** **92488**

Armed Services Technical Information Agency

Reproduced by

DOCUMENT SERVICE CENTER

KNOTT BUILDING, DAYTON, 2, OHIO

This document is the property of the United States Government. It is furnished for the duration of the contract and shall be returned when no longer required, or upon recall by ASTIA to the following address: Armed Services Technical Information Agency, Document Service Center, Knott Building, Dayton 2, Ohio.

NOTICE: WHEN GOVERNMENT OR OTHER DRAWINGS, SPECIFICATIONS OR OTHER DATA ARE USED FOR ANY PURPOSE OTHER THAN IN CONNECTION WITH A DEFINITELY RELATED GOVERNMENT PROCUREMENT OPERATION, THE U. S. GOVERNMENT THEREBY INCURS NO RESPONSIBILITY, NOR ANY OBLIGATION WHATSOEVER; AND THE FACT THAT THE GOVERNMENT MAY HAVE FORMULATED, FURNISHED, OR IN ANY WAY SUPPLIED THE SAID DRAWINGS, SPECIFICATIONS, OR OTHER DATA IS NOT TO BE REGARDED BY IMPLICATION OR OTHERWISE AS IN ANY MANNER LICENSING THE HOLDER OR ANY OTHER PERSON OR CORPORATION, OR CONVEYING ANY RIGHTS OR PERMISSION TO MANUFACTURE, USE OR SELL ANY PATENTED INVENTION THAT MAY IN ANY WAY BE RELATED THERETO.

CONFIDENTIAL

**NOTICE: THIS DOCUMENT CONTAINS INFORMATION AFFECTING THE
NATIONAL DEFENSE OF THE UNITED STATES WITHIN THE MEANING
OF THE ESPIONAGE LAWS, TITLE 18, U.S.C., SECTIONS 793 and 794.
THE TRANSMISSION OR THE REVELATION OF ITS CONTENTS IN
ANY MANNER TO AN UNAUTHORIZED PERSON IS PROHIBITED BY LAW.**

AD No. 92488

ASTIA FILE COPY

CONFIDENTIAL

NAVORD REPORT

4197

REPORT OF THE CONFERENCE ON EXPLOSIVE SENSITIVITY HELD AT
THE U. S. NAVAL ORDNANCE LABORATORY

FC

22 DECEMBER 1955



U. S. NAVAL ORDNANCE LABORATORY
WHITE OAK, MARYLAND

CONFIDENTIAL

MAY 11 1956

56AA

20553

This document is CLASSIFIED and shall be safeguarded in accordance with the security provisions of U. S. Navy Regulations. It is forbidden to make extracts from or to copy this classified document without specific approval of the Chief of Naval Operations or originator, as applicable, except as provided for in article 9-10 of the United States Navy Security Manual of Classified Matter.

CONFIDENTIAL
NAVORD Report 4197

REPORT OF THE CONFERENCE ON EXPLOSIVE SENSITIVITY
HELD AT THE U. S. NAVAL ORDNANCE LABORATORY

28-29 JUNE 1955

SPONSORED BY THE EXPLOSIVES RESEARCH DEPARTMENT OF THE
U. S. NAVAL ORDNANCE LABORATORY

U. S. NAVAL ORDNANCE LABORATORY
White Oak, Silver Spring, Maryland

56AA 20553
CONFIDENTIAL

CONFIDENTIAL
NAVORD Report 4197

NAVORD Report 4197

22 December 1955

This report is a record of the conference on the Sensitivity of Explosives held at the U. S. Naval Ordnance Laboratory, 28-29 June 1955. The meeting was called after an extensive survey of Explosives Laboratories in the United States had been made by the Explosives Research Department of the U. S. Naval Ordnance Laboratory. The purpose of the meeting was to bring together those scientists whose interest in the subject was high in order that the most important phases of the problem could be discussed.

The suggestions and comments made during the meeting are informal opinions of the participants. They do not represent the official opinions of the Naval Ordnance Laboratory although they may be used to formulate plans for future work.

The report has been prepared by the chairman, H. D. Mallory.

To all of those who participated in the conference, the Naval Ordnance Laboratory expresses its sincere appreciation.

J. T. HAYWARD
Commander, NOL
Captain



PAUL M. FYE
By direction

CONFIDENTIAL
NAVORD Report 4197

TABLE OF CONTENTS

| | Pages |
|---|-------|
| 1. List of Participants..... | 1-2 |
| 2. Schedule of the Meeting..... | 3 |
| 3. Questions Posed To and Raised by the Participants. | 4-8 |
| 4. Broad Objectives of this Conference..... | 9 |
| 5. A Survey of Various Explosives Laboratories in the United States..... | 10-18 |
| 6. Chairman's Report; Discussion Panel on Methods of Sensitivity Testing..... | 19-21 |
| 7. Chairman's Report; Discussion Panel on the Chemical Kinetics of Sensitivity..... | 22-23 |
| 8. Chairman's Report; Discussion Panel on the Role of Crystal Structure In The Sensitivity of Solid Explosives..... | 24-25 |
| 9. Chairman's Report; Discussion Panel on the Role of Physical Properties as Related to Sensitivity..... | 26-28 |
| 10. Post Discussion Items..... | 30 |
| 11. Minimum Ignition Energies and Sensitivities..... | 31-32 |
| 12. Comments on "Complete Run-Down Method" of Impact Testing..... | 33-35 |
| 13. Monitor System for Impact Tests..... | 36 |
| 14. Sensitivity of Explosives to Uniform Shocks..... | 38-39 |
| 15. References..... | 41 |
| 16. Laboratory Scale Test Device to Determine Sensitivity of Explosives to Initiation by Setback Pressure..... | 42 |
| 17. Summary of Suggestions..... | 44-46 |

CONFIDENTIAL
NAVORD Report 4197

ILLUSTRATIONS

| | Pages |
|---|-------|
| Figure 1. Transmission of Detonation Experiment.... | 15 |
| Figure 2. Comparison of Impact Data with Tools Giving High Confinement of the Sample.... | 16 |
| Figure 3. Sensitivity Inversions..... | 31 |
| Figure 4. Proposed Monitoring Station for Impact Sensitivity Testing..... | 37 |
| Figure 5. Sensitivity of DDNP As a Function of Density..... | 40 |
| Figure 6. Schematic of a Propellant Driven Impact Device..... | 43 |

CONFIDENTIAL
NAVORD Report 4197

LIST OF PARTICIPANTS

1. James E. Ablard, Explosives Research Department, Naval Ordnance Laboratory.
2. Lee Ashton, Arthur D. Little, Inc.
3. T. G. Blake, Explosives Division, Olin-Mathieson Chemical Corp., East Alton.
4. T. L. Brownyard, BuOrd, U. S. Navy Department.
5. L. Bulfinch, Picatinny Arsenal
6. D. L. Coursen, Eastern Laboratory, E. I. DuPont de Nemours and Co.
7. Clyde O. Davis, Eastern Laboratory, E. I. DuPont de Nemours and Co.
8. Harry W. Fox, Surface Chemistry Division, Naval Research Laboratory.
9. Paul M. Fye, Explosives Research Department, Naval Ordnance Laboratory.
10. William A. Gey, Chemistry Division, Naval Ordnance Test Station.
11. A. F. Giacco, Experiment Station, Hercules Powder Co.
12. James R. Holden, Explosives Chemistry Division, Naval Ordnance Laboratory.
13. E. L. Kreidl, Arthur D. Little, Inc.
14. Oscar Levine, Chemistry Division, Naval Research Laboratory.
15. H. Dean Mallory, Fuels and Propellants Division, Naval Ordnance Laboratory.
16. J. T. Manley, Research and Development Division, Naval Mine Depot, Yorktown.
17. Walter C. McCrone, Armour Research Foundation.
18. William S. McEwan, Chemistry Division, Naval Ordnance Test Station.

CONFIDENTIAL
NAVORD Report 4197

LIST OF PARTICIPANTS (CONT.)

19. Anthony O. Mirarchi, National Fireworks Ordnance Corporation, National Northern.
20. Evan C. Noonan, Fuels and Propellants Division, Naval Ordnance Laboratory.
21. Karl Ottosen, Picatinny Arsenal.
22. Otis K. Pennington, Explosives Division, Naval Ordnance Test Station.
23. Raymond Pepinsky, Department of Physics, Pennsylvania State University.
24. Julius Roth, Experiment Station, Hercules Powder Co.
25. Darrell V. Sickman, Explosives Chemistry Division, Naval Ordnance Laboratory.
26. Gilbert B. L. Smith, Explosives Research Department, Naval Ordnance Laboratory.
27. Louis C. Smith, Los Alamos Scientific Laboratory.
28. George F. Strollo, BuOrd, U. S. Navy Department.
29. Robert W. Van Dolah, Explosive and Physical Science Division, U. S. Bureau of Mines.

CONFIDENTIAL
NAVORD Report 4197

The meeting proceeded according to the following schedule:

Morning Session, 28 June 1955

1. Welcome and preliminary remarks by Capt. J. T. Hayward, USN, Commander of the Naval Ordnance Laboratory; Dr. G. K. Hartmann, Technical Director; and Dr. Paul M. Fye, Chief, Explosives Research Department.
2. Statement by Dr. G. B. L. Smith outlining the scope and plans of the present meeting along with some future aims.
3. Report by Dr. H. D. Mallory concerning the present status of work on explosive sensitivity by laboratories in the United States.
4. General discussion of the status report.

Prior to the meeting, participants had been assigned to one of four working groups for the purpose of discussing specific questions which had been proposed.

Afternoon Session

1. Meetings of the working groups.

Morning Session, 29 June 1955

1. Reports and recommendations from the chairman of the working groups.
2. Discussion of the recommendations.
3. Summary.

Afternoon Session

1. General discussion.

CONFIDENTIAL
NAVORD Report 4197

QUESTIONS POSED TO AND RAISED BY THE PARTICIPANTS

A. Kinetics

1. Can activation energies which are measured at low temperatures be correlated with sensitivity? Which test methods would be most likely to show such correlation?
2. What are the best techniques for measuring activation energies?
3. Are a hopeless number of independent reaction paths operative in the sequence: initiation, growth and stable detonation?
4. Is it possible to use high-speed electronic techniques to measure reaction rates and activation energies during progress of a detonation wave?
5. What sequence of reactions occurs in composite explosives- for example in a TNT-aluminum mixture?
6. What is the mechanism of sensitization of nitromethane by amines?
7. Can chemical catalysts or inhibitors be of use in suppressing unwanted detonation?
8. Is there a relation between the minimum energy required to ignite an explosive (which subsequently burns) and its sensitivity?
9. Can a minimum "initiation" energy be separated from and proved common to, all test methods?
10. Are not all questions in connection with sensitivity merely questions of the transformation of energy from one form to another?
11. Can we at the present time state what an explosive is sensitive to in the sense of heat, temperature or energy?
12. What is the significance of the dependence of sensitivity on the rate of energy application?
13. There have been reports to the effect that a given explosive can have a higher detonation velocity in the

CONFIDENTIAL
NAVORD Report 4197

pressed form than it does in the cast form, both at the same bulk density. Usually the pressed form appears more sensitive in the gap test. Can these observations be related along kinetic lines?

B. Crystal Structure

1. Have a sufficient number of crystal structures been determined to allow a correlation with sensitivity? If not, can a series of explosives be selected whose structures could be reliably determined?
2. Certain explosives form polymorphs of greatly different sensitivities. Which properties are different in such cases -- compressibility, hardness, density, melting point, coefficient of friction of the various surfaces, heat of fusion and sublimation, etc. Can any of these differences be related to sensitivity?
3. Is there any possibility of measuring burning or detonation rates along various crystal axes?
4. Can minimum initiation energies be determined for various crystal faces?
5. What is the best explanation for effects of crystal size or habit?
6. What is the role of strains in crystals and can they influence sensitivity properties?
7. Should the anisotropic properties of explosive crystals be studied?
8. Can correlation be made between sensitivity and crystal imperfections?

C. Physical Properties

1. A common device for desensitizing nitroglycerine is to gel it with nitrocellulose. What is the explanation of this effect?
2. Can crystalline explosives be colloidized?
3. What reasons can be advanced to explain sensitivity differences for a given explosive just above or below its

CONFIDENTIAL
NAVORD Report 4197

melting point?

4. Why is one explosive more sensitive as a solid, another more sensitive as a liquid?
5. What role does viscosity play in sensitivity?
6. Has the surface chemistry of explosives received the proper amount of study?
7. Are coefficients of friction on various crystal surfaces of given explosives available?
8. In the absence of sensitizing grits what are the relative importance of compressibility, hardness, heat of fusion, etc?
9. Are there any known wax-like explosives which are highly sensitive?
10. How much desensitization by wax is due to lubrication, how much to bulk dilution?
11. Could high pressure lubricants be more effective as desensitizers than waxes?
12. In some instances explosives appear less sensitive on the impact machine after waxing but more sensitive by the gap test. Can this be explained?
13. Can we state the importance of defects in loaded munitions such as cracks in pressed charges and moisture in cast materials?
14. If initiation and growth of explosion can be separated, which physical or chemical properties are of specific importance in the two stages?
15. Would work on the pressure index of burning for high explosive be profitable at this time?
16. What results might be expected from the study of an homologous series of explosives due to attendant changes in physical properties through the series?

CONFIDENTIAL
NAVORD Report 4197

D. Test Methods

1. Are there ways to modify impact machines so that energy distribution can be accounted for quantitatively?
2. What is the best explanation for the observation that some explosives show inverted sensitivity in the gap test as compared to the impact test?
3. Can sensitivity tests be devised which permit measurement of single variables?
4. Is it possible to separate the property of sensitivity into physical and chemical aspects? An attempt to do this was published in the Japanese Journal of the Military Explosive Society, 1936 (translation issued as NavOrd Report 2579 dated 1952).
5. Does the initiation time depend on initial temperature?
6. Initiation delay during impact has received only slight attention. Would experiments designed to measure these times be useful?
7. Can an impact machine designed for variable compression time be of use?
8. Is it feasible to try to analyze where all the energy goes during the impact of a falling weight?
9. Is pure shock initiation a promising approach in the study of sensitivity? If so, how can such experiments best be done.
10. Can experiments be devised which distinguish between initiation due to surface effects and other causes within the body of a sample?
11. From the theoretical standpoint is it necessary to distinguish between initiation and growth of explosion?
12. From the practical standpoint can proper projectile design help to increase safety with loaded munitions?
13. Are the tails of the statistical distribution curves for the impact test of sufficient importance to justify the greatly increased labor necessary to get them directly? Can these tails be obtained mathematically from relatively few measurements around the 50% point?

CONFIDENTIAL
NAVORD Report 4197

14. Can better friction tests be devised?
15. Would it be helpful to prepare and distribute standard explosive samples to the various laboratories?

CONFIDENTIAL
NAVORD Report 4197

BROAD OBJECTIVES OF THIS CONFERENCE

G. B. L. Smith

Explosives chemists and technologists have recognized for some time that measurements designed to evaluate sensitivity were satisfactory only in a limited degree. Impact sensitivity machines are almost universally employed but results obtained vary from machine to machine, operator to operator, etc., as to actual numbers and also as to the relative sensitivity of series of compounds. Your speaker at first was of the opinion that carefully controlled tests on standardized samples should be carried out by all laboratories, which could be interested, however, this was carried out shortly after the close of World War II and the results after statistical analysis clearly demonstrated that the situation was one approaching chaos.

Dr. Fye, Dr. Ablard and others in this Laboratory discussed the problem and concluded that the real difficulty was a lack of understanding of the real nature of sensitivity. The explosives Research Department of NOL requested Dr. Mallory and the speaker to visit the principal Explosives Laboratories in this country for the purpose of learning what work is in progress, and where there is talent and interest. Some twenty-five activities were visited and Dr. Mallory will report to you on the facts we learned from these visits.

It appears that much effort has been expended on the study of sensitivity in an empirical manner and many more or less "standard" tests have been devised. But it is also clear that basic research and semi-programmed research designed to give us a better knowledge of sensitivity is desirable.

This group has been invited to NOL for this meeting so that a survey of the present status may be made and tentative plans for future work be formulated. A group in the United Kingdom rather formally organized to co-ordinate this type of work is in existence. It is hoped that our group will at some later time co-ordinate its effort with that of the United Kingdom. I wish to thank all who have come here and hope that you will feel that your time has been profitably spent.

CONFIDENTIAL
NAWORD Report 4197

A SURVEY OF VARIOUS EXPLOSIVES LABORATORIES
IN THE UNITED STATES

H. D. Mallory

A year and a half ago Dr. G. B. L. Smith and I began a survey of the major explosives laboratories in this country for the purpose of determining the extent of interest in the subject of explosive sensitivity and to determine which laboratories were doing or could do research along these lines. The survey eventually included the following 25 groups:

1. Picatinny Arsenal.
2. Naval Ordnance Test Station, Chemistry Division, Research Department.
3. Naval Ordnance Test Station, Explosives Division, Propellant and Explosives Department.
4. Naval Mine Depot, Yorktown.
5. Naval Powder Factory, Indian Head.
6. Armour Research Foundation.
7. Atlas Powder Co., Reynolds Experiment Station.
8. Hercules Powder Co., Experiment Station.
9. E. I. DuPont de Nemours Co., Eastern Laboratory.
10. Aberdeen Proving Ground, Ballistics Research Laboratory.
11. Naval Proving Ground, Dahlgren.
12. Redstone Arsenal, Rohm and Haas.
13. Redstone Arsenal, Thiokol Corporation.
14. Redstone Arsenal, Rocket Development Laboratory.
15. Olin-Mathieson Chemical Corp., East Alton, Ill.

CONFIDENTIAL
NAWORD Report 4197

16. National Fireworks Ordnance Corp.
17. Holston Defence Corp.
18. Wabash River Ordnance Works.
19. Bureau of Mines, Division of Explosives Technology, Region V.
20. Naval Ammunition Depot, Crane
21. The Bureau of Explosives
22. A. D. Little and Co.
23. University of Wisconsin, Naval Research Laboratory, Department of Chemistry.
24. Jet Propulsion Laboratory
25. Aerojet General Corp.

We were extremely pleased by the high interest shown by all of these groups. Understandably, laboratories concerned with handling explosives are vitally interested in the safety of their personnel and are anxious to further work which will contribute to increased safety. In addition to safety per se, the armed forces are committed to research programs directed toward the discovery of new explosives which are more powerful and better adapted to ordnance applications than those now known.

A number of new explosives have been synthesized which are more powerful than any now in use. Unfortunately, most of them seem to be too sensitive for immediate application. From the practical standpoint, therefore, it is most desirable to understand and to be able to control this property of sensitivity. In addition to new explosive compounds, a number of special formulations have been developed which have superior performance in air blast or underwater applications. Some of these also have proven troublesome from the standpoint of sensitivity to the extent that they will not be used unless they can be rendered more safe to handle.

The advent of high speed, high altitude planes have forced additional requirements onto our anti-aircraft defenses. These requirements involve better air blast performance, and

CONFIDENTIAL
NAVORD Report 4197

higher shell fragment velocities together with higher muzzle velocity of the shells. In general the first two requirements call for more powerful explosives. According to most evidence now available, this is incompatible with the third requirement which calls for decreased sensitivity in order to allow higher set-back forces without a premature explosion.

One ordinarily speaks of sensitivity as an inherent property of an explosive compound; yet it is not a property in the usual sense but actually combines both intensive and extensive features. Perhaps the most difficult aspect of the problem is this indefinite characteristic. Ideally, one would wish for a single test which would allow prediction of initiation behavior under any circumstance. But experience indicates that this is not possible and our next alternative should be to understand the primary mechanisms of initiation to the extent that sensitivity can be predicted under various conditions.

Despite its known inadequacy, the most universally used test at the present time is the impact machine. A number of instances are known where identical machines give different results on the same explosive, or even where the same machine gives different results at different times. Since machine design varies from one laboratory to the next it is difficult, at best, to compare data or to decide if the results are due to machine variables or to explosive variables. Indeed, good correlation of impact data from different laboratories is almost the exception instead of the rule. Despite the unsatisfactory nature of impact testing it will apparently continue to be the most widely used method and should, therefore, receive continued study aimed at improvement. In addition, owing in large measure to the efforts of British workers, our present base of knowledge is wider for this test than any other; which might imply useful results from relatively small effort.

The impact machine would seem to simulate accident conditions better than most tests. However, the problem of shell prematures from strong set-back forces can possibly be better understood by something similar to the gap test. Also, it would appear that the gap test must involve fewer variables than the falling weight impact and in this way it would be more tractable and useful as a basic approach. It is hoped that our survey, this meeting, and future meetings, will stimulate and further sensitivity research as well as provide guidance for our own group at the Naval Ordnance Laboratory.

The complexity of the problem requires the application of knowledge from many separate fields: rheology, lubrication,

CONFIDENTIAL
NAWORD Report 4197

kinetics, and crystal structure are a few of them. Recent literature, especially from the classified sources, is scattered. For this reason we have considered the advisability of a complete literature search covering not only explosive sensitivity itself but also related fields which it is believed will contribute to the final solution. The Library of Congress has submitted estimates for a bibliography of this type. Funds for this work are not now available, although the cost of the project is being considered and weighed against the good results expected from such an expenditure. Much of the war-time work on sensitivity done at the Explosives Research Laboratory, Bruceton, Pa., is unknown or unavailable to workers in this field. We have also considered the desirability of collecting these and other reports for reissue under a single cover as a second step toward distribution of available data. I believe the circulation of existing data, which at present is somewhat scattered and uncoordinated although it is potentially of great value in the solution of the present problem, would necessarily stimulate and further future work.

Some recent or current projects which have especially interesting features are as follows:

1. Naval Mine Depot

The Research and Development Laboratory at this installation has worked out a system whereby one gram samples can be tested in their impact machine. Commonly, impact tests are done on samples ranging in size from 10 mg up to 50 mg. Since it is fairly well established that results can and do vary with sample size, it is instructive to have large sample data for comparison. Early workers were more concerned with the question of whether or not explosion of the sample was complete or partial or, indeed, whether detonation had actually occurred. The NMD data is interesting in this regard since the sample is highly confined in a cylinder fitted with a blow-out plug and although explosion of the sample is extremely vigorous, the relatively sensitive Composition A does not explode completely in this test and portions of the unburned sample can usually be recovered.

These NMD experiments cover the intermediate sample size range between the usual test and the 25g samples used at Picatinny Arsenal. The Picatinny Arsenal machine, I understand, is no longer in operation nor have I seen results of those tests. But this is an example of the non-availability of data already in existence and makes me the more anxious to see such data collected and given general distribution. Of course, once one knows certain data to exist he can usually

CONFIDENTIAL
NAVORD Report 4197

find it somewhere. This is of little help if the experiments are not known to have been done and I have the distinct impression that more work has been done than is generally known.

2. Armour Research Foundation

At Armour, work has been done on coating ammonium perchlorate grains with ammonium fluoroborate. These two materials possess similar crystal habits and the fluoroborate can be grown on the perchlorate grains in such a way as to prevent contact of the oxidizer and the combustible material in the explosive formulation. The mechanism of wax desensitization seems basic to this work. The fluoroborate layer covers and protects the perchlorate grain in a manner which seems similar to the wax coating of an explosive crystal. The lubricating action present with wax coatings is absent in this case and so this approach might represent a separation of variables helpful in understanding the action of wax coatings.

3. Naval Research Laboratory

Some interesting work at this laboratory has been carried out by Fox and Levine which includes wettability studies and contact angles between explosive crystals and various additives, and especially the coating of explosives with monolayers. This work also correlates with the usual wax coating techniques and the fluoroborate coatings just mentioned.

An important consideration involved in wax additions to explosives is whether or not the observed desensitization is due primarily to lubrication or to a bulk effect involving wax compressibility or to the heat of explosion decrement which occurs with inert dilution. The addition of monolayers to explosive crystals offers a further method for the separation of variables since these monolayers can change the friction characteristics between crystals while at the same time the bulk properties of the explosive are virtually unchanged. It might be noted here that the addition of wax commonly desensitizes explosives for the impact test, but may actually sensitize a material in the gap test. This seems especially true with any composition having more than about 70% TNT. Results after the addition of grit, help point up differences between these two tests since grit commonly sensitizes an explosive to impact but can decrease sensitivity as measured by the gap test.

CONFIDENTIAL
NAVORD Report 4197

4. Eastern Laboratory, E. I. DuPont de Nemours and Co.

One of the current projects at this laboratory involves the transmission of detonation across an air gap. The experimental arrangement, as shown in Figure 1, is a pentolite booster encircled by a rim of explosive similar to the rim of a wheel encircling the hub. The explosive

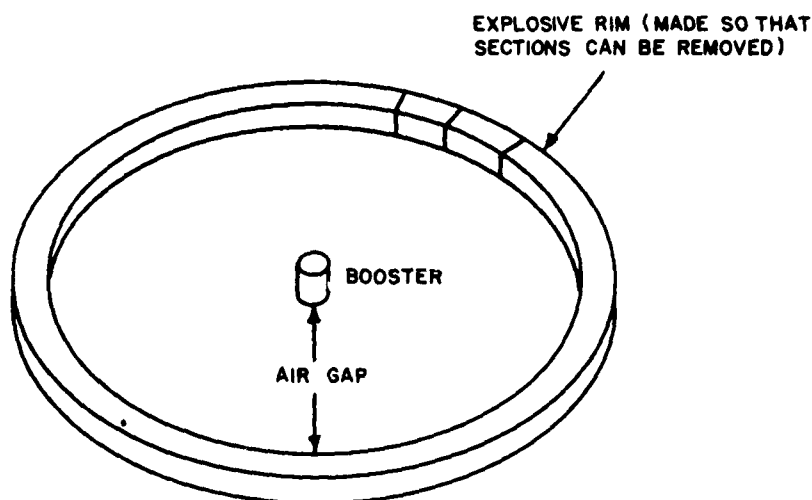

FIG. 1 TRANSMISSION OF DETONATION EXPERIMENT

rim is cast not as a single piece but rather in wedges which can be removed from it so as to vary the presented cross-section. A surprising feature of this experiment is the fact that initiation transmission across the gap is strongly dependent on the presence of corners due to absent sections. Although initiation may be positive at a given rim radius and with one or more rim sections removed, the probability of initiation drops very sharply when a complete rim is used.

5. A. D. Little and Co.

This group has recently been engaged in the study of controlled cavities in explosive charges. The shape, size, and position of these cavities along with the composition of the contained gas has been shown to influence the sensitivity of the charge as a whole. The test method in this case is to enclose the charge in a lead sheath and to explode it by the drop of a 125 pound weight. The experiment itself is a large scale impact test although it was designed to simulate the conditions which obtain on set-back of a high explosive shell during firing.

CONFIDENTIAL
NAVORD Report 4197

6. Naval Powder Factory

Data from this laboratory which appear particularly interesting to me are not new although adequate explanation should be extremely helpful toward the determination of impact machine variables. Their machine design is such that samples are highly confined; similar to the so-called Bruceton Type 5 impact tool. The test, as performed, shows the remarkable result that ammonium picrate is more sensitive than lead azide under these conditions. No ERL data exists on lead azide with the Type 5 tools and so direct comparison cannot be made. However, the available data for picric acid, tetryl, and others, show general similarities with data obtained by the Powder Factory. This can be seen in Figure 2.

Figure 2

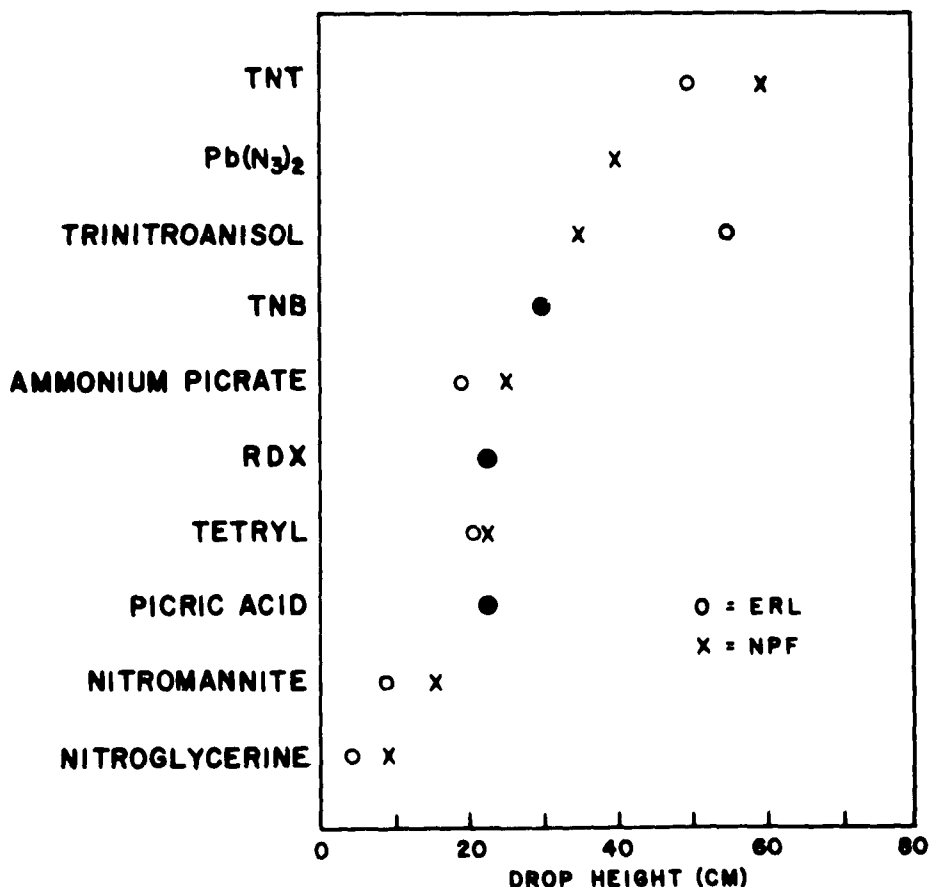

Comparison of impact data between type 5 tools (Explosives Research Laboratory, Bruceton Pa) with the machine currently used at the Naval Powder Factory, Indian Head, Md.

CONFIDENTIAL
NAVORD Report 4197

Early in World War II, many impact tool designs were conceived, tested, and discarded. Those which were eventually accepted were the so-called Type 12 for solid explosives and the Type 13 for liquid materials. These tools are essentially the same, being flat impact surfaces of relatively large diameter, but the Type 12 plunger rests directly on the solid sample. The Type 13 is the same tool but with the plunger supported by a small wooden toothpick above a drop of liquid on the anvil. These tools were selected for routine use primarily for one reason: the 50% explosion points obtained gave the best agreement with experience estimates of the relative order of sensitivity of the common explosives. The fact that different machines of the same design can be in disagreement, is an obvious reason showing something further to be required. At least one of the further requirements would be an exact knowledge of machine variables such as impact velocities and durations, pressures, effect of tool hardness, and the effect of sample confinement, to mention a few. Existing data on earlier tool types which have not found acceptance in rating relative sensitivities, may be of decided value in the study of machine variables. For here, the applied pressure has been changed by changed tool diameters, tool surfaces have been systematically changed and tested, and different types of confinement have been used.

The testing of liquid explosives under confinement, such as with the Type 5 tool, shows the rather remarkable result that 50% points for nitroglycerin and molten materials such as TNT, Composition B, EMMET and picric acid, can all be essentially the same; that is, about 10 cm. drop height for a 5 kg weight.

These results may have a logical explanation if we consider the effect of the physical state of the explosive, especially the apparent viscosity of solid samples and unspecified crystal differences. The Type 12 tool, being a flat impact surface, offers poor confinement for the sample so that a waxy explosive can escape the impact surfaces more quickly than can a gritty material. Indeed, on this test a common occurrence is that waxy explosives cannot be fired, whereas gritty explosives are rate highly sensitive. One can virtually cancel out viscosity differences by providing confinement as with the Type 5 tool. The spread between the most and least sensitive in this case is considerably less than without confinement. However, there must still be differences due to the variation of compressibility or crystal properties which exist between one compound and another. One can minimize these differences by melting, and in the liquid state these compounds make their nearest approach to uniform physical conditions. As was already mentioned, a number of explosives show the same sensitivity under these conditions.

CONFIDENTIAL
NAVORD Report 4197

whereas they are normally widely separated. An alternative explanation may be that initiation is being brought about by entrapped air bubbles. This possibility should be investigated, since, if true, the implication is that physical properties of the samples are of lesser importance than is suggested by the first explanation proposed.

These have been our preliminary efforts, results, and findings. The most consistently expressed viewpoint which this survey has brought out is that the subject of sensitivity is of vital concern and importance and that all groups are interested to the extent of helping further the work in whatever way they are most able. This viewpoint has been subject to only one condition; namely, that the effort be planned and coordinated to the greatest extent possible. This has been a prime consideration for sponsoring the present meeting. The plan of this meeting is for informal discussion of the problem in its broadest aspect: what has been done in the past, what can be done now, and what should be done in the future. For this purpose, a long list of possible topics has been written out and grouped under four major classifications: Chemical Kinetics, Crystal Structure, Physical Properties, and Testing Methods. Each participant has been assigned to a group according to his experience and interest.

The results of the meeting will be used to guide the efforts of our group at the Naval Ordnance Laboratory and will undoubtedly be helpful to others also. Future meetings and activities will, to a considerable extent, depend on the outcome of the present discussion. Certainly the potential for further advances will be inherent in them.

CONFIDENTIAL
NAVORD Report 4197

CHAIRMAN'S REPORT, DISCUSSION PANEL ON
METHODS OF SENSITIVITY TESTING

The panel convened at 1:30 PM in the Jungle Room. Those in attendance were:

L. C. Smith: Chairman
James E. Ablard
Lee Ashton
L. Bulfinch
D. L. Coursen
A. F. Giacco
E. L. Kreidl
J. T. Manley
Karl G. Ottosen
Otis K. Pennington
George F. Strollo

For the most part, the discussion revolved around drop-weight impact machines and impact sensitivity test procedures. Attempts by the Chairman to steer the discussion into other channels were unsuccessful, and it developed that there was a very significant reason for this, namely, the drop-weight impact test is the only sensitivity test in sufficiently general use to provide a basis for common understanding and discussion by those present. While several laboratories made occasional use of other testing methods (for the most part field proof-testing), and while some research work was in progress with novel laboratory tests (notably by NOTS and NOL), these were only briefly and sporadically discussed.

There appeared to be no question that the drop-weight impact test is a convenient and useful measure of relative sensitivities in spite of its various idiosyncracies. The meaning of such tests was the subject of a spirited discussion in which it was emphasized by the writer that drop-weight impact machines are designed and calibrated to indicate the relative average response which a given explosive might give to some complex summation of the various types of accidental blows and impacts to which an explosive might be subjected, rather than to provide a quantitative assessment of the response of an explosive to some specific stimulus, such as the impact of a bullet or the shock from a detonator.

Some time was devoted to a discussion of whether or not a serious attempt should be made to standardize the machines and test procedures at the various explosives laboratories. It was decided that this proposal was neither economically feasible nor

CONFIDENTIAL
NAVORD Report 4197

necessarily desirable, quite aside from any questions of the probable difficulties involved in changing the long-established habits and customs at a number of organizations. Modern impact machines are expensive devices, costing some \$5000 for the machine and supporting facilities and equipment. Furthermore, G. F. Strollo (BuOrd) emphatically presented an interesting objection to the idea as a representative of the consuming services. His argument, basically, was as follows: As is well known, the apparent sensitivity of some given explosive may appear quite different in one impact machine than it does in another. If some new explosive is tested in several machines of different design, and is found to be sufficiently insensitive in all of them, one feels with some confidence that the material is safe to handle. On the other hand, such an explosive might appear reasonably insensitive in one machine, but rather sensitive in another. Such a material would justifiably have to be viewed with suspicion until further information from other test methods and experience in handling the material had been obtained. In other words, Strollo felt that the atypical results occasionally produced by different machines comprise useful information which should not be standardized out.

E. L. Kreidl (Arthur D. Little) suggested that perhaps the most useful standard machine would be one equipped with several sets of interchangeable tools representing the most reliable of the various types in current use. While this suggestion met with general approval, it was considered unprofitable to devote further time to the matter in view of the aforementioned economic (and other) problems.

It was next suggested that it might be worthwhile to have some agency prepare standard samples of some five or six common explosives, covering the useful range of sensitivity, to be distributed to and tested by the various service and contractor laboratories, more or less along the lines of the 1945 Navy comparison test. The sole purpose of this is to provide for general distribution of up-to-date information on the sensitivity scales being obtained at the various explosives laboratories so that impact sensitivity data reported on new compounds and mixtures may be interpreted elsewhere in terms of recent data produced by the same machine on familiar materials.

The question of friction sensitivity tests next arose, and it was clear that there was considerable interest in such a test, and that no satisfactory test was yet available. A few unsuccessful attempts to develop friction sensitivity tests were described. The common difficulty appeared to be that the devices tried could produce explosions only with PETN or more sensitive materials, a range too limited to be useful. No active projects

CONFIDENTIAL
NAVORD Report 4197

on friction sensitivity came to light, although several people seemed to be giving thought to the matter with the intention of making further attempts to develop a suitable test.

The panel had by now exhausted the time available and adjourned.

CONFIDENTIAL
NAVORD Report 4197

CHAIRMAN'S REPORT, DISCUSSION PANEL ON
CHEMICAL KINETICS OF SENSITIVITY

Panel Members

William S. McEwan: Chairman
Paul M. Fye
A. D. Mirarchi
Evan C. Noonan
G. B. L. Smith

The question as to whether reaction kinetic studies from which activation energies are obtained at relatively low temperatures can help in understanding the sensitivity of an explosive perhaps can be best answered indirectly after the consideration of what is meant by sensitivity, what kind of quantity it is, how it is measured, and what its significant factors are. Analytical examination as a quantity shows sensitivity to be neither a pure intensive nor a pure extensive quantity of the system but to have the aspects of both. For example, we say that some explosives are more sensitive than other explosives and we attempt to arrange explosives in an order of increasing sensitivity. These are characteristics of an intensive quantity (as one body is hotter than another). On the other hand, they are evidences that the quantity of explosive present is a factor in determining whether or not it will explode. (For example, it is common practice in determining the heats of combustion of explosive materials wherein explosion is undesirable to reduce the size of the sample being burned if evidence of explosion are observed.) In most cases a maximum sample size can be arrived at for which no explosion occurs. Experiments can be found wherein apparently the rate of flow of energy into an explosive rather than the actual amount of energy added is the important step in determining whether detonation occurs. At the Naval Ordnance Test Station it has been shown by means of a shock tube that small samples of explosives may be exposed to temperatures of the order of several thousand degrees in the shock front without being exploded. In some instances there was evidence of melting of the surface of the explosive not usually believed capable of melting. These observations seem to indicate that there are "quantity effects" in the term sensitivity.

From these considerations, it is believed that the quantity sensitivity is not one similar to temperature, pressure, or EMF, and that no one is going to build a single meter, like a thermometer, in which a sample of explosive may be placed and

CONFIDENTIAL
NAVORD Report 4197

an indication given as to the value of sensitivity but rather that this quantity must be arrived at by the measurement of a number of quantities and an expression may, perhaps, be derived from them which will give a value of the susceptibility of an explosive to explode in response to outside stimulation. Consideration should now be given as to what kinetics can do to help understand the process and to derive the form of the above expression. Measurement of the rate of a reaction is essentially to give information as to the path of a particular reaction. If a particular reaction is made up of a number of different steps, then it is necessary to try to determine what these particular steps are and whether the reaction follows this course under all stimuli. There is also the question of whether all explosives in arriving at the stage of detonation go through the same general sequence of reactions. Kinetic studies of a specific reaction which may be postulated as leading to an explosion may well indicate the probability of this step occurring. Such answers can help in the above questions. Once it has been determined what the particular course or sequence of events leading to explosion is, then the determination and examination of the activation energies of the individual steps may give an indication as to what is the rate limiting step.

In conclusion, it appears that what is needed is a complete job of research done on related series so that all factors and facets postulated as contributing to sensitivity may be examined and given their proper weight. Such things as crystal structure, chemical composition, polymorphism, heat capacity, thermal diffusivity, crystal defects, stress, and size of crystallites should all be determined for a particular series and the attempt made to correlate these factors and see how they fit in with the picture of sensitivity. At NOTS an attempt in this direction was made on a series of cobalt amino azides. In this series the molecule can be made decreasingly polar by the introduction of azide groups into the coordination sphere of the cobalt. In preliminary experiments this has had the effect of increasing the sensitivity as measured by drop test on a Bruceton type machine. A plot of log of the impact height for 50% explosion vs. the number of azide groups in the coordination sphere gave a straight line. This work was initiated several years ago but had to be suspended due to loss of personnel, the work however, has been reinstigated at least during the summer and it is hoped that it will be possible to extend it so that eventually all the quantities mentioned above can be determined. It is hoped that other groups will undertake the doing of a complete job on a limited series of explosives rather than merely trying to satisfy the day to day need for information as to sensitivity by more and more drop height measurements on new explosives.

CONFIDENTIAL
NAVORD Report 4197

CHAIRMAN'S REPORT, DISCUSSION PANEL ON THE ROLE OF CRYSTAL
STRUCTURE IN THE SENSITIVITY OF SOLID EXPLOSIVES

The Panel on the Role of Crystal Structure in the Sensitivity of Solid Explosives consisted of the following:

Robert W. Van Dolah: Chairman
James R. Holden
Oscar Levine
Walter C. McCrone
Raymond Pepinsky

The Panel spent a considerable amount of time in considering the questions that had been proposed to it, with the following conclusions:

There have not been sufficient crystal structure determinations made to allow correlation of structure with sensitivity. In fact, we feel that we are not yet sufficiently sophisticated to know whether such a correlation can be made, given additional structures. However, we feel that additional structures should be determined and this will be discussed below. We felt very strongly the lack of information with respect to the physical properties of solid explosives. We listed the physical properties in three categories, anisotropic, isotropic and subtle. Anisotropic properties include compressibility, hardness, coefficient of thermal expansion, refractive index, thermal conductivity, light absorption and piezoelectricity. Isotropic properties consist of transition temperatures, heats of formation, heat of fusion, density, specific heat, heat of solution, heat of transition, and heat of vaporization. The third category includes many properties that we feel to be of greatest importance. These are the subtle properties which include polymorphic forms and their transitions, the effect of crystal size, of strain concentration, the effects of crystal habits, the effect of dislocations and inclusions. These latter may largely be lumped into the category of imperfections in crystals; what they are, what effects they have on sensitivity and how to control them.

We discussed the information that we have available pertinent to the role of these subtle properties, such as the role of the energy of transformation of polymorphs which has been determined for HMX. It was our feeling that this energy of transformation could only enter into the sensitivity considerations in a small way but the true significance is difficult to evaluate. HMX exhibits a considerable change in sen-

CONFIDENTIAL
NAVORD Report 4197

sitivity of its several polymorphs with crystal size. While the energy of transformation of the polymorphs could contribute to this change it is felt that the concentrations of strains in larger crystals are more responsible for the increased sensitivity observed in the larger crystals. Similarly, the data that has been obtained recently on the effect of strain concentrations in lead azide was discussed. It has been observed that an eight-fold increase in 50 percent point of drop height in an impact sensitivity test was observed with a corresponding decrease in strains in the crystals.

The Panel raised questions bordering on the mechanism of initiation and steady state propagation of the detonation wave with respect to the phenomenon of dead pressing and the recently established capability of single crystals to detonate. It was generally felt that we are not yet in an adequate position to resolve the apparent conflicts of these two observations.

We considered the question of the role of burning as a function of the crystal axis or face involved. We had some questions as to the immediate pertinence of this information though admitted a possible application to the problem of non-steady state propagation from initiation to detonation.

The Panel presented the following firm recommendations for future work:

1. There is a very great need for the determination of more physical properties on common explosives. Perhaps of greatest significance is the very difficult job of establishing the nature and role of what are listed above as subtle properties of the crystals.

2. There is a great need for additional crystal structure data on common explosive materials. We are very pleased to see the progress that has been made at Pennsylvania State University on the polymorphs of HMX and feel that it is very important to see this work completed on all polymorphs. There is great need for the crystal structure of RDX, TNT and Lead Azide, realizing that all three of these represent very difficult structures to elucidate.

3. A general study is needed on the role of imperfections in crystals in sensitivity.

CONFIDENTIAL
NAVORD Report 4197

CHAIRMAN'S REPORT, DISCUSSION PANEL ON THE ROLE OF
PHYSICAL PROPERTIES AS RELATED TO SENSITIVITY

Panel Members

Clyde O. Davis: Chairman
T. G. Blake
T. L. Brownyard
Harry W. Fox
Julius Roth
Darrel V. Sickman

The Physical Properties Panel discussed the probable dependence of accidental explosions of military explosives on the physical properties of and the physical conditions around the explosive. The subject was deliberately treated in its broadest aspect because the purpose of the panel was to view the entire expanse of the current area of ignorance in this field, and then to try to select specific topics for research. Both solid and liquid explosives were considered, and both crystalline explosive compounds, mixtures of explosives, and mixtures containing one or more nonexplosive ingredients such as metallic fuels and oxidizing salts.

The Panel considered such important causes of accidental explosions as:

- (1) Relatively slow heating of a confined charge such as cook-off in a gun barrel or frictional heating of a projectile in flight.
- (2) Setback or acceleration effects.
- (3) Penetration of cased charges by bullets and high-speed fragments.
- (4) Impact delivered through a metal case to an explosive charge.
- (5) Rubbing or crushing of explosives between metal surfaces.
- (6) Sympathetic detonation of cased or uncased charges.
- (7) Static electricity.

CONFIDENTIAL
NAVORD Report 4197

It is of interest that (1) involves conduction of heat from outside into the explosive charge and (2), (3), (4), (5), and possibly (6) involve degradation of mechanical energy to heat. Thus in most cases one is concerned with the role of physical properties in determining how and where mechanical energy will be converted to heat.

The role that might logically be played by physical properties and conditions in these accidental explosions, and the relative importance of various properties in a given case, can be guessed in advance only if a theory of the initiation and growth of explosion is available. The panel accepted, for this discussion, the widely held theory that all accidental explosions start at a point or region where heat has been generated or released in such a way that rapid decomposition of a sufficiently large amount of explosive occurs. In most instances the occurrence of an accidental detonation, or of a damaging explosion, will be a two-step process. The first step will be the initiation of decomposition of explosive. If confinement, pressure index of decomposition, etc., are such as to accelerate the rate of decomposition, Step II will follow. Step II may ensue in a time ranging from microseconds to seconds, and may range in violence from a mere pressure-rupture of a cased charge to a high-order detonation.

The panel compiled a list of some 25 physical properties and conditions that are known to be or suspected to be involved either in getting a decomposition started or causing it to become an explosion. It was of interest to try to group together or classify these properties in some manner that would indicate their probable function and their relative importance. Some consideration was first given to trying to list the physical properties that might be involved in a specific kind of accidental explosion such as explosion by bullet impact. This kind of analysis is feasible, but there was insufficient time to do anything with it during the panel meeting.

An interesting and informative way to group physical properties in this study is with respect to their role in starting a dangerous decomposition or in preventing the decomposition or causing it to stop.

Properties of solids which will be important in determining how and where mechanical energy is converted to heat are:

- (1) Particle hardness
- (2) Coefficient of friction between explosive particles, between particles of explosive and nonexplosive, and between explosive and casing.

CONFIDENTIAL
NAVORD Report 4197

- (3) Rheology, or high-pressure viscosity, and heat evolved for a given rate of shear.
- (4) Particle size, shape, and surface condition.
- (5) Porosity and compressibility.

Properties having to do with dissipation of heat are:

- (1) Thermal conductivity
- (2) Specific heat
- (3) Melting point, heat of fusion, and sublimation
- (4) Particle density and bulk density.

The foregoing properties are expected to come into play during the explosion-producing incident. There are certain other properties that may be effective only in conditioning the explosive prior to the incident. Among these are the coefficient of thermal expansion and the hygroscopicity.

In all cases except where detonation starts with no induction period, the activation energy, the pressure index or coefficient of burning, the degree of confinement, and the amount of explosive involved or available to become involved in the initiation step will be very important.

Many of the physical properties of explosives which the panel considered important have never been measured, even for the more common military explosives. Moreover, the apparent lack of correlation between the sensitivity of explosives as measured by various tests of sensitivity and known physical properties of explosives suggests a possibly complicated relationship involving groups of properties. The experimental correlation of physical properties with sensitivity appears to be a monumental job which may never get done.

The panel considered two experimental approaches to a better understanding of the relationship between sensitivity or explosibility by accidental means and physical properties of solid explosives. The preferred approach is to select several standard explosives such as TNT, tetryl, RDX, PETN, and ammonium picrate. Compare their sensitivities on carefully run tests such as a bullet test, impact test, explosion temperature test, minimum primer test, and then measure and compare the values of the physical properties which are considered significant and try to develop a consistent correlation between properties and test results. It is realized of course that in any such study

CONFIDENTIAL
NAVORD Report 4197

thermodynamic properties will be extremely important and must be obtained for all explosives considered.

An objective of the foregoing study would be the development of an all-purpose sensitiveness test to replace the impact test. One such test might involve the release of energy at different rates into small confined samples of explosive.

Another approach to an understanding of the role of physical properties is to devise a mathematical model which could contain appropriate terms for the known modes of heat generation and dissipation. Limits could be derived for the amount of heat and rate of heating for a given amount of a particular explosive which would produce explosion in a predicted percentage of the trials. This is admittedly a difficult approach to a complicated problem, but in the long run probably the most fruitful of significant results.

The physical properties of liquid explosives which are believed to be important are the viscosity, density, specific heat, thermal conductivity, compressibility, pressure index of burning, and the various other thermodynamic properties.

The theory of initiation and explosion which the panel embraced for this discussion permits the prediction that in the case of granular solid explosives, resistance to initiation by most causes will result from lubrication of all particle surfaces and provision of various heat sinks, or heat absorbers, within the explosive, especially between a metal case and its explosive charge.

It is recommended that the impact tests which allegedly indicated that liquid TNT is as sensitive as nitroglycerin should be repeated. This work might profitably be followed by a study of various aliphatic nitrates to find out which of their physical properties can be correlated with sensitiveness.

CONFIDENTIAL
NAVORD Report 4197

POST DISCUSSION ITEMS

The following section contains short discussions of topics which were mentioned during the meeting. The topics are:

- (1) Minimum Ignition Energies and Sensitivities,
E. C. Noonan.
- (2) Comments on "Complete Rundown Method of Impact Testing", A. Bulfinch.
- (3) An Energy Monitoring System for Impact Testing,
A. O. Mirarchi.
- (4) Sensitivity of Explosives to Uniform Shocks,
W. A. Gey and Arthur L. Bennett.
- (5) Laboratory Scale Test Device to Determine Sensitivity of Explosives to Initiation by Setback Pressures,
Lewis Jablansky, Picatinny Arsenal.

CONFIDENTIAL
NAVORD Report 4197

MINIMUM IGNITION ENERGIES AND SENSITIVITY

E. C. Noonan

U. S. NAVAL ORDNANCE LABORATORY

In studying the ignition of propellants considerable evidence points to the conclusion that the minimum energy required to make a propellant ignite and burn is a function of the rate of energy application (i.e., flux). Ignition energies obtained by forced convection of gases, free convection of gases, compression of gases, and radiation can be correlated by a plot of $\log Q$ vs. $\log Q/t$, where Q is the minimum ignition energy per unit area, Q/t the flux. For a typical propellant Q may be 8 cal/cm² for an application time of 30 sec, and only 0.3 cal/cm² if heated in 3 milliseconds. Minimum ignition energies for a number of explosives have been determined and are comparable to propellants. Suppose techniques can be developed to measure ignition energies over very short times. We may expect a relationship of the type shown in Figure 3.

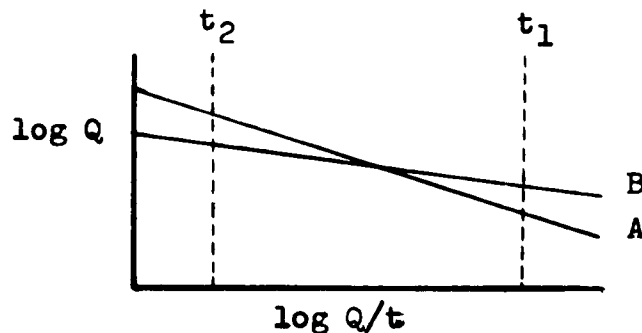

Figure 3

When the curves for two explosives are determined they may have different slopes such as A and B. If we apply energy in a short time (dotted line t_1) explosive A requires less energy to initiate it than B and A appears more sensitive. If we use a longer time to add energy, as with an impact machine (dotted line t_2) A appears less sensitive than B. This kind of thing may very well explain inversions of sensitivity that are observed when gap tests and impact machine results are compared. For example, liquid TNT is far less sensitive than solid TNT with the gap test, but some results on the impact machine indicate that liquid TNT is more sensitive than solid.

CONFIDENTIAL
NAVORD Report 4197

If techniques can be developed which enable us to develop curves of the type indicated one could predict the sensitivity to be expected under different circumstances.

CONFIDENTIAL
NAVORD Report 4197

COMMENTS ON "COMPLETE RUN-DOWN METHOD"
OF IMPACT TESTING

A. Bulfinch

Picatinny Arsenal

Picatinny has investigated and evaluated the relative merits of the "Up-and-Down" and "Complete Run-Down" methods using the Picatinny Arsenal apparatus. The results of the investigation are summarized below:

Up-and-Down Method

1. Biased data is obtained since it is all collected around the 50% point.
2. Estimated standard deviations are consistently low as a result of the biased data.
3. In spite of the low standard deviations, poor agreement between operators was obtained.
4. Assumption that data is log-normally distributed is not valid for the Picatinny apparatus.
5. Method of calculating the average and standard deviation is not valid since there is no adjustment for the various sample sizes used at the various height levels.
6. No measure of sensitivity in the tails of the curves is made. This is an important deficiency from a safety point of view.

Complete Run Down Method

1. Unbiased data is obtained since data is collected over the full range from Zero percent to 100 percent explosions.
2. Unbiased estimates of the standard deviation are obtained since the data is representative of the parent population.
3. Good agreement between operators was obtained.
4. No assumption about the form of the distribution is made. Instead the form can be determined with a reasonable degree of confidence since data over the full range is available.

CONFIDENTIAL
NAVORD Report 4197

5. The method of calculating the average and standard deviation is valid - the usual grouped data calculations can be used.

6. A measure of sensitivity in the tails of the curves is obtained.

This work has shown that the relative sensitivities (at the 50% point) of the explosives used are as follows:

| <u>Explosive</u> | <u>Sensitivity, inches</u> |
|------------------|----------------------------|
| Tetryl | 16.0 |
| TNT | 18.1 |
| RDX | 21.1 |
| Composition B | 24.3 |

As shown in the following table, the relative order of sensitivity of Comp B, RDX, TNT and Tetryl in the area of the 50% point is the reverse of the order in the area of the one percent point. These calculated values were obtained using the averages and standard deviations (at the 50% point) obtained by means of the PA apparatus, "Run-Down" method, and the assumption of normality.

Probability of an Explosion based on the
Assumption of Normality

| <u>Explosive</u> | <u>Impact Height, inches</u> | |
|------------------|------------------------------|-----------------------|
| | 24 | 8 |
| Comp B | $\frac{50\%}{50\%}$ | $\frac{2.0\%}{2.0\%}$ |
| RDX | 70 | 1.0 |
| TNT | 94 | 0.3 |
| Tetryl | 99.9 | 0.07 |

This apparent reversal of relative sensitivities is due to the fact that all of the cumulative frequency curves for these explosives were found to intersect at the seven percent point. However, the order of relative sensitivities shown above in the area of the one percent point is not valid for the following reasons:

CONFIDENTIAL
NAVORD Report 4197

1. The order is not based upon significant differences.
2. The magnitude of the calculated probabilities of an explosion in the area of the one percent point is not valid since actual large sample measurements show these values to be in error. The results of the actual large sample measurements are compared with calculated results obtained thru the assumption of normality in the following table:

Probability^a of an Explosion at a Height of Eight Inches

| Explosives | No. of Trials | Binominal | | Extrapolation from 50% Point Using Assumption of Normality | |
|------------|---------------|-------------------|----------------------------------|--|----------------------|
| | | No. of Explosions | Actual Measurements ^b | Run-Down Method ^b | Up-and-Down Method |
| RDX | 350 | 6 | 0.63-3.75 | 0.71-1.25 | 1.0×10^{-6} |
| Tetryl | 1000 | 4 | 0.11-1.02 | 0.05-0.10 | — |
| Comp B | 1000 | 1 | 0.00-0.56 | 1.66-2.28 | — |

a At the 95% confidence level

b Confidence intervals for the PA apparatus

The above results show the following:

1. The sensitivities of Comp B and Tetryl are not significantly different at an impact height of 8 inches. Or more exactly, the difference between the sensitivities of Comp B and Tetryl could not be detected at an impact height of 8 inches with a sample size of 1000.
2. The sensitivity curves of Comp B and Tetryl deviate significantly from the normal in the lower end of the curves and in opposite directions.

From this, it has been concluded that the sensitivity characteristics in the lower tails of the curves are unique for each explosive and that the assumption of normality or any other single distribution for all explosives is not valid. This is important from a safety standpoint.

CONFIDENTIAL
NAVORD Report 4197

MONITOR SYSTEM FOR IMPACT TESTS

During the discussion of impact testing, the point was made that in general we do not know where the impact energy goes -- into the sample, into the weight as rebound energy, etc. Dr. A. O. Mirarchi, National Northern, mentioned an energy monitor system and has submitted a drawing, figure 4, to illustrate his suggestion.

Some work along these lines has been done by Grey which is briefly described by Bowden and Yoffe².

² Bowden and Yoffe, Initiation and Growth of Explosion, Cambridge, 1952, page 38.

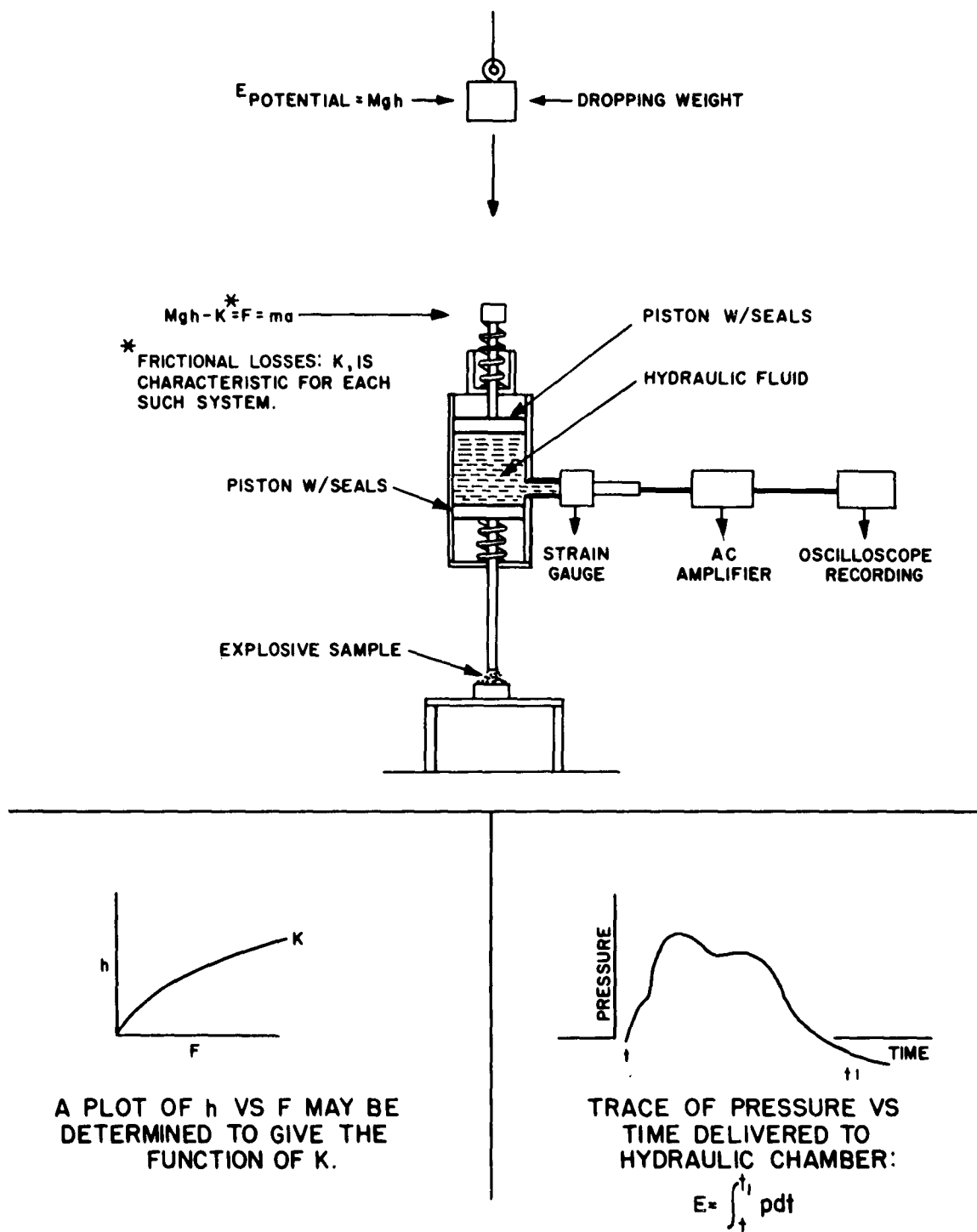

FIG. 4 PROPOSED MONITORING STATION FOR IMPACT SENSITIVITY TEST

CONFIDENTIAL
NAWORD Report 4197

SENSITIVITY OF EXPLOSIVES TO UNIFORM SHOCKS

by

W. A. Gey and Arthur L. Bennett

U. S. Naval Ordnance Test Station, China Lake, California

The "influence" test of sensitivity of explosives to explosive shocks is a valuable criterion for determining, on the basis of past experience, the suitability of explosive components in explosive applications¹. It does require substantial quantities of explosive and hence is not applicable as a laboratory sensitivity test for new explosives which may be available only in small amounts. Furthermore, no mathematical treatment of decaying shock can be easily applied to determine initiation energies.

Because it is possible to set up uniform shocks in a shock tube with speed, temperature, pressure, and duration of shock compression accurately controlled, we have undertaken an investigation of the initiation of reaction of explosive materials by such shocks. The use of the forward facing shock in an inert atmosphere appears to provide a reproducible experimental determination of the relation between the energy density, temperature, and pressure requirements for initiation of very small samples.

The shock tube is 6.4 cm² in cross section, the high pressure end being an 11 cm long cylinder and the low pressure chamber a 75 cm long square section with observation windows 23 cm in length at the downstream end. Hydrogen is used as the driver gas, argon as the inert atmosphere, and the shock is formed by puncturing a .010 in cellulose acetate diaphragm which separates the high and low pressure chambers. The explosive is contained in a metal cup facing the diaphragm and positioned on the axis of the expansion chamber in the end of a probe of suitable length inserted through a threaded opening on the closed end of the expansion chamber. The axial dimensions of the tube and the positioning of the samples are designed to expose the explosive to the head-on shock of Mach 5 to 7 for periods of 60 to 120 μ sec, and to cool the heated argon by the rarefaction wave before the shock reflected from the closed end of the expansion chamber reaches the sample. Calculations according to Lobb² were carried out on IBM 701 equipment to obtain for each of 8 shock strengths (pressure ratio across the shock) between Mach 5.67 and Mach 6.83, the particle velocity, shock zone duration, shock zone temperature, and speed of the reflected shock. The values were plotted against initial pressure ratio to obtain interpolated values.

CONFIDENTIAL
NAVORD Report 4197

The explosive holder is necessarily small to avoid excessive interference with the shock wave and damage by the reaction of the explosive. Most of the observations were made using steel cups 0.76 mm deep, 1.54 mm or 2.34 mm ID, and some with a cup 1.27 mm deep, 2.82 mm ID, all having 0.38 mm wall thickness. The sample sizes varied with the leading pressure, but were of the order of 2.5, 4.0, and 9 mg., weighed to $\pm .1$ mg after loading. The explosives were loaded by hand pressing, using rams slightly smaller than the inside diameter of the cup. The largest cup was loaded at uniform density by one pressing in a loading jig, the excess sample being cut off level with a razor blade.

Observation of the initiation of the explosive was made with a drum camera focused on the sample cup through a 1 mm slit parallel to the tube axis. The luminosity of the interaction of the shock front with the target and of the reaction products was photographed.

Lead styphnate, 4,6-dinitrobenzene-2-diazo-1-oxide (DDNP), tetracene, nitrosoguanidine, lead azide, and nitroglycerin have been subjected to the shock tests. Lead styphnate appears to be the most sensitive, being initiated by shocks of Mach 4 to 4.5. Next in sensitivity is DDNP which has been extensively studied. It is reproducibly initiated by shocks of Mach 5.5 to 6.3. With shocks of this strength the self-luminosity is sufficient for photographic recording.

The sensitivity, expressed as go or no-go results as a function of the shock strength, is essentially independent of the exposed area of the sample. As expected from Eyring's treatment¹, sensitivity is quite dependent on the density of the sample, as shown in Figure 5.

A study of the relation between sensitivity and energy density in the shock zone is being undertaken, since the absolute pressure in the shock can be varied while holding other parameters constant. Results to date indicate that as the energy density is decreased, the shock strength must be increased to obtain initiation. Photographic data also indicate that initiation occurs as a result of shock front-explosive interaction and that the sensitivity is not a function of the shock zone duration.

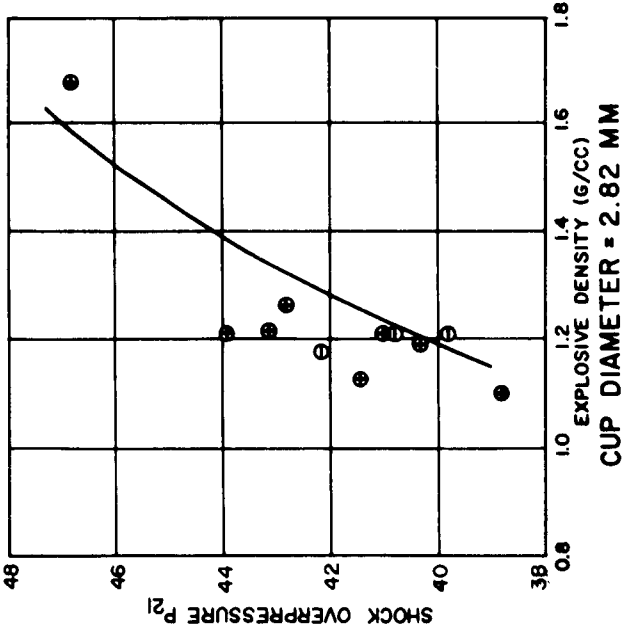

● = FIRE
 ○ = MISFIRE
 P = PARTIAL

EACH GRAPH IS COMPOSED OF TWO AREAS SEPARATED BY THE INDICATED CURVES. ON ONE SIDE OF A CURVE, IGNITION OCCURS WHILE ON THE OTHER SIDE IT DOES NOT.

FIG. 5 SENSITIVITY OF DDNP AS A FUNCTION OF DENSITY AT AN INITIAL PRESSURE OF $P_{21} = 50$ MM Hg

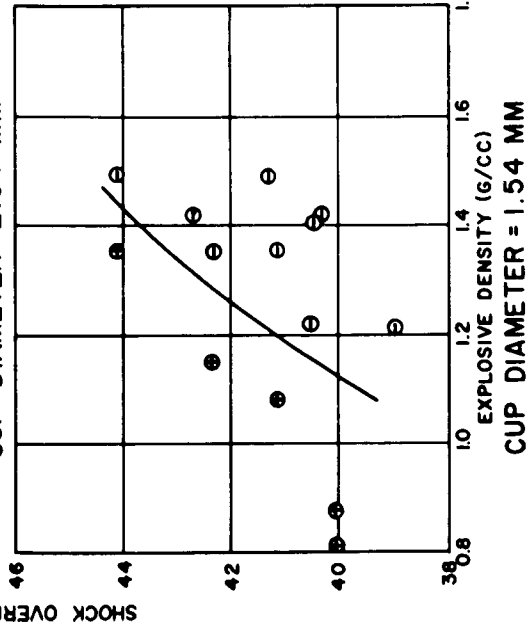
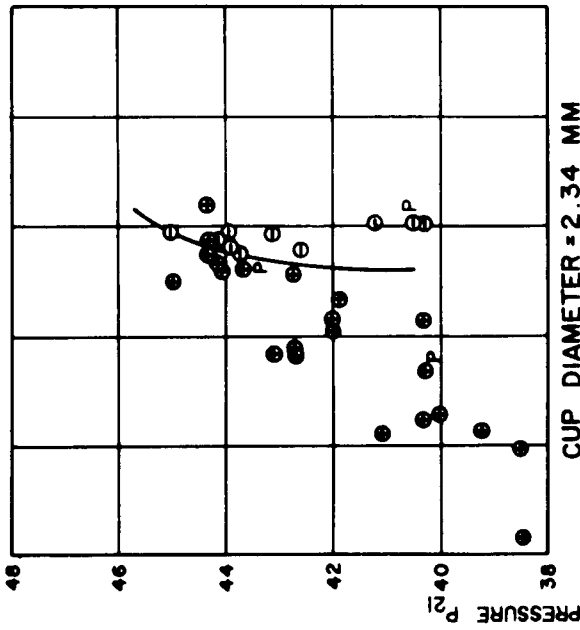

CONFIDENTIAL
NAVORD Report 4197

REFERENCES

- 1 H. Eyring, et. al. Chemical Reviews 45, 69 (1949), treat this calibrated shock sensitivity test in detail.
- 2 R. K. Lobb. NOLM 10494. U. S. Naval Ordnance Laboratory Memorandum. "On the Length of a Shock Tube". 17 June 1950. U. S. Naval Ordnance Laboratory, White Oak, Silver Spring, Maryland.

CONFIDENTIAL
NAVORD Report 4197

LABORATORY SCALE TEST DEVICE TO DETERMINE
SENSITIVITY OF EXPLOSIVES TO INITIATION BY
SETBACK PRESSURE*

L. Jablansky

Picatinny Arsenal

The subject device is basically a simple piece of equipment. Mechanically, it consists of a propellant chamber, an explosive test chamber, a back-up plate, and a means for igniting the propellant and transmitting a compressive force to the test explosive. Figure 6 is a crude schematic of the operating mechanism.

The device is operated as follows:

A propellant charge is weighed into a small powder bag and a M1A1 squib is inserted into the bag. The test explosive charge (approx. 5 gm) is assembled for compression by being properly aligned between the piston in the propellant chamber and the dead stop. The propellant charge is assembled to the leads of the electrical firing head. The test explosive sample is enclosed by a barricade, the instrumentation is checked, and the charge is electrically fired. The rapid compression of the explosive either does or does not result in a detonation. In the prototype device (which is currently obsolete), the propellant burning chamber was designed for maximum working pressures of 15,000 to 20,000 psi, which translated to the HE charge represent pressures of 60,000 to 80,000 psi. In the prototype, these pressures could be obtained with approximately 5 to 6 gm of M9 propellant powder.

The purpose of the test equipment is to provide a controlled means for subjecting explosives to simulated setback forces such as are created in the firing of a gun. By means of this equipment, such factors as adiabatic compression, density, and the presence of grit, cavitation and desensitizer can be quantitatively studied for their effect on the sensitivity of Composition B to initiation by setback pressure. Furthermore, this test is potentially capable of being developed as a quantitative impulse sensitivity test for explosives.

Further details are contained in Picatinny Arsenal Report No. 2235, "Laboratory Scale Test Device to Determine Sensitivity of Explosives to Initiation by Setback Pressure, Introductory Report", dated August 1955.

* From a letter to H. D. Mallory by L. Jablansky, Picatinny Arsenal.

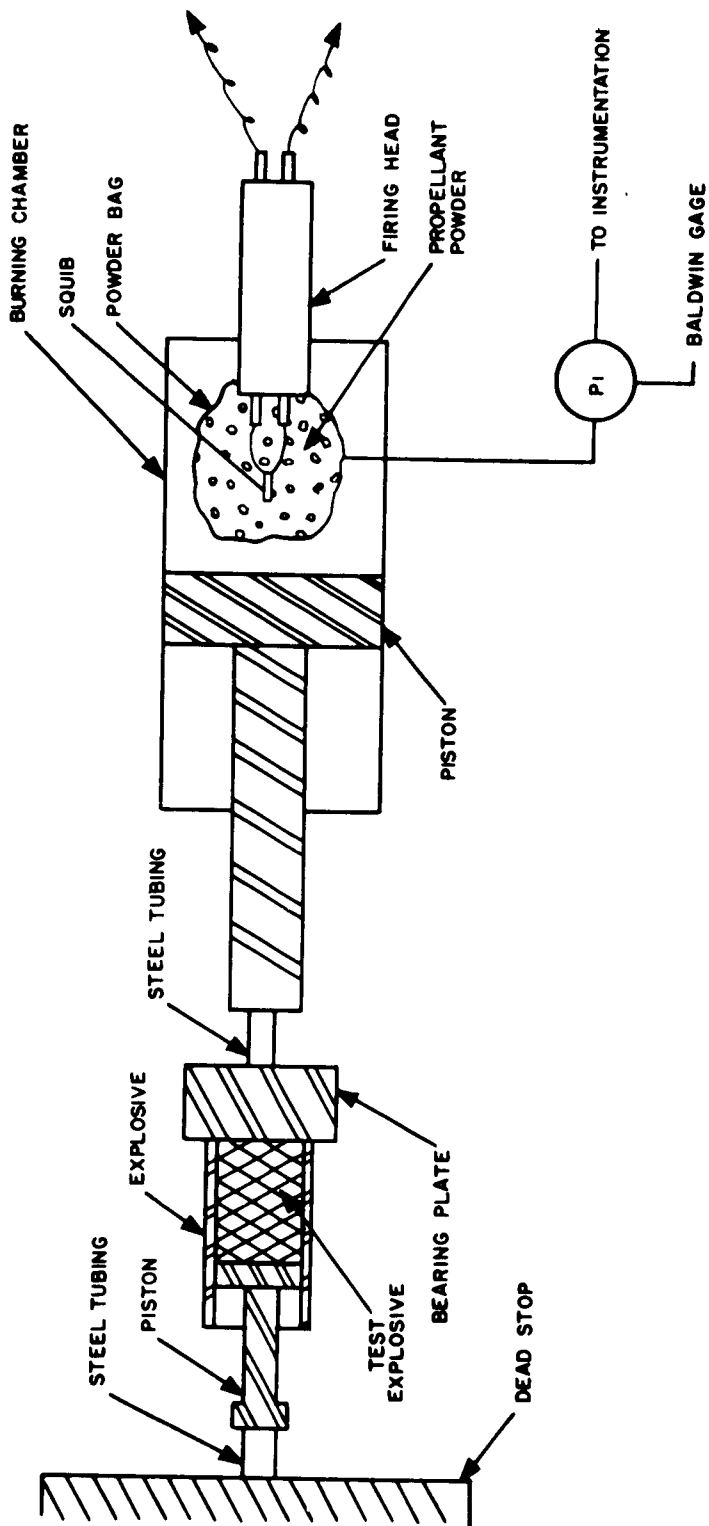

FIG. 6 SCHEMATIC OF TEST DEVICE

CONFIDENTIAL
NAVORD Report 4197

SUMMARY OF SUGGESTIONS

A few of the suggestions generated at this conference are of a general nature and can be taken as a basis for future operation:

- (1) Systematic work, both basic and semi-programmed, should be undertaken in those areas which are known to be important but which are not now receiving attention.
- (2) The present program should be coordinated with that which exists in the United Kingdom.
- (3) Provision should be made for holding other meetings from time to time as a means of stimulating the work and disseminating the results.

Other suggestions were specific and for the most part represent a recognized need for information now, in order to interpret existing data and to improve current methods of test:

Testing

- (1) In compression tests (impact machine, booster, gap, bullet or set-back test) a study should be made of sensitivity as a function of loading times.
- (2) Tests or theoretical treatments are needed which will separate shock and friction effects.
- (3) More data should be accumulated in the tail regions of the statistical distribution curves for the various tests. At the one end, for determination of firing reliability of explosives devices; at the other end, for evaluating the safety hazard in the field and in the plant.
- (4) Standard samples of the common high explosives should be prepared and distributed to all laboratories doing sensitivity testing in order that currently used impact machines may be evaluated and ranked with others for the benefit of management and operating personnel.
- (5) Strain gauge measurements can be made in conjunction with impact tests for the additional information obtainable: for example, explosion times, pressures, and loading and unloading times of the falling weight.
- (6) Attention must be paid to the rate of energy application to explosives in all tests.

Physical Properties

(7) At least one related series of compounds should be investigated in which the physical properties are known completely. The properties can include

- crystal habit
- chemical composition
- polymorphism
- heat capacity
- crystal defects
- residual stresses
- size of crystallites
- hardness
- coefficients of friction
- viscosity at high pressure
- heat evolved for a given rate of shear
- porosity
- compressibility
- thermalconductivity
- heats of fusion and sublimation
- pressure index of burning
- coefficient of thermal expansion
- hygroscopicity

A knowledge of such properties seems vital to the whole problem of explosive sensitivity.

CONFIDENTIAL
NAVORD Report 4197

Crystal Structure

(8) Additional crystal structure data for important explosives should be obtained. Especially needed are data for RDX, TNT and $\text{Pb}(\text{N}_3)_2$.

(9) More attention must be paid to the subtle properties of crystals making up the explosive. In general, these properties are classed as crystal imperfections and include polymorphic forms and their transitions, effects of size and of strain concentrations, crystal habits, and dislocations and inclusions.

Kinetics

(10) The decomposition paths of the important explosive decompositions should be studied and activation energies determined.

(11) An investigation of the decomposition of explosives at various rates should be undertaken. A series such as the azidothiocarbonates may be suitable since their rate of decomposition can be controlled over wide limits from hours to immediate detonation.

CONFIDENTIAL
NAVORD Report 4197

DISTRIBUTION LIST

| | No. of Copies |
|---|------------------|
| Olin-Mathieson Chemical Corporation, East Alton, Ill. Via: InsMat | |
| Attn: T. G. Blake..... | 3 |
| Attn: Mr. F. R. Seavey..... | 1 |
| Eastern Laboratory, E. I. DuPont de Nemours and Co. Via InsMat, Wilmington, Del. | |
| Attn: Dr. Clyde O. Davis..... | 3 |
| Attn: Dr. D. L. Coursen..... | 1 |
| Armour Research Foundation, Chicago, Ill. Via InsMat | |
| Attn: Dr. Walter C. McCrone..... | 3 |
| National Northern Division, National Fireworks Ordnance Corporation, West Hanover, Mass. Via InsMat | |
| Attn: Dr. A. D. Mirarchi..... | 3 |
| Department of Physics, Pennsylvania State University, Via ONR, State College, Penn. | |
| Attn: Prof. Raymond Pepinsky..... | 1 |
| Atlas Powder Co., Reynolds Experiment Station, Tamaqua, Pa. Via: InsMat..... | 2 |
| Redstone Arsenal, Huntsville, Alabama | |
| Attn: Rohm and Haas..... | 1 |
| Attn: Thiokol Corporation..... | 1 |
| Attn: Rocket Development Laboratory..... | 1 |
| Holston Defence Corporation, Kingsport, Tenn. Via: InsMat..... | 1 |
| Wabash River Ordnance Works, Newport, Indiana Via: InsMat..... | 1 |
| Commanding Officer, U. S. Naval Ammunition Depot Crane, Indiana..... | 1 |
| University of Wisconsin, Naval Research Laboratory, Department of Chemistry, Madison 6, Wisconsin. Attn: Prof. J. O. Hirshfelder, Via: ONR..... | 1 |
| Jet Propulsion Laboratory, Pasadena, Calif. Attn: Mr. G. Robillard, Via: InsMat..... | 2 |
| Aerojet General Corporation, Azusa, California Attn: Dr. M. H. Gold, Via InsMat..... | 2 |
| Atlantic Research Corporation, 812 North Fairfax Street, Alexandria, Va., Via: InsMat..... | 1 |
| University of Utah, Salt Lake City, Utah. Attn: Prof. Melvin Cook, Via: ONR..... | 2 |
| Southwest Research Institute, San Antonio, Texas, Attn: Dr. James H. Weigand, Via ONR..... | 2 |
| Chief, Armed Forces Special Weapons Project P. O. Box 2610, Washington, D. C..... | 3 |

CONFIDENTIAL

CONFIDENTIAL
NAVORD Report 4197

DISTRIBUTION LIST (CONT.)

| | No. of Copies |
|--|------------------|
| Chief, Bureau of Aeronautics, Department of the Navy, Washington 25, D. C..... | 3 |
| Chief, Bureau of Ordnance, Washington, D. C. | |
| Attn: Re06..... | 1 |
| Attn: ReU3..... | 1 |
| Attn: Ad6..... | 1 |
| Chief, Bureau of Ships, Washington, D. C. | |
| Attn: Code 423..... | 2 |
| Chief, Office of Naval Research, Washington, D. C. | |
| Attn: Dr. Ralph Roberts..... | 3 |
| Attn: Dr. L. Butz..... | 3 |
| Chief of Ordnance, Department of the Army, Research and Development Division, Attn: ODTM Washington, D. C..... | 5 |
| Chief of Engineers, Department of the Army, Washington, D. C. Attn: Research and Development Division.... | 3 |
| Commander, Air Material Command, Wright-Patterson Air Force Base, Dayton, Ohio..... | 2 |
| Commander, Naval Ordnance Test Station, China Lake, California..... | 2 |
| Attn: Dr. W. A. Gey..... | 1 |
| Attn: K. S. Skarr..... | 1 |
| Attn: O. K. Pennington..... | 1 |
| Attn: Dr. W. S. McEwan..... | 2 |
| Commander, Air Force Armament Center Eglin Air Force Base, Eglin, Fla..... | 1 |
| Commanding General, Frankford Arsenal, Philadelphia, Pa. | 3 |
| Commanding Officer, Engineer Research and Development Laboratories, Fort Belvoir, Va..... | 3 |
| Commanding Officer, Naval Mine Depot, Yorktown, Va.... | 1 |
| Attn: J. T. Manley, Research and Development Laboratory..... | 1 |
| Attn: G. Svadeba, Research and Development Laboratory..... | 1 |
| Commanding Officer, Naval Powder Factory, Indian Head, Md..... | 1 |
| Attn: Dr. Sol Skolnik..... | 2 |
| Attn: A. Owyang..... | 1 |
| Attn: J. A. O'Callaghan..... | 1 |
| Attn: R. H. Kray..... | 1 |

CONFIDENTIAL

CONFIDENTIAL
NAVORD Report 4197

DISTRIBUTION LIST (CONT.)

| | No. of Copies |
|---|------------------|
| Commander, Air Material Test Center, Eglin Air Force Base, Eglin, Fla..... | 1 |
| Commander, Norfolk Naval Shipyard, Portsmouth, Va. Attn: Code 290..... | 1 |
| Commanding Officer, Picatinny Arsenal, Dover, New Jersey..... | 1 |
| Attn: Mr. Karl Ottosen..... | 3 |
| Attn: Mr. A. Bulfinch..... | 1 |
| Commanding Officer, Watertown Arsenal, Watertown, Mass | 2 |
| Director, New Mexico Institute of Mining and Technology Research and Development Division, Socorro, New Mexico, Via ONR..... | 2 |
| Director, Naval Research Laboratory, Washington, D. C..... | 2 |
| Attn: Harry W. Fox..... | 1 |
| Attn: Oscar Levine..... | 1 |
| Director, National Bureau of Standards, Washington, D. C. Attn: Ordnance Division..... | 3 |
| Director, Los Alamos Scientific Laboratory P. O. Box 1663, Los Alamos, New Mexico Via: InsMat..... | 3 |
| Attn: Dr. L. C. Smith..... | 1 |
| Director, Applied Physics Laboratory, Johns Hopkins University, 8621 Georgia Ave., Silver Spring, Md. Via: ONR, Attn: Dr. G. B. Swartz..... | 2 |
| Director, U. S. Bureau of Mines, 4800 Forbes Street Pittsburgh, Pa..... | 2 |
| Attn: Dr. R. W. Van Dolah..... | 3 |
| Director, Ballistics Research Laboratory, Aberdeen Proving Ground, Aberdeen, Maryland..... | 3 |
| Attn: D. C. Vest..... | 1 |
| Attn: Dr. Jane Dewey..... | 1 |
| Hercules Powder Co., Experiment Station, Wilmington, Del. Via: InsMat..... | 1 |
| Attn: Dr. R. W. Lawrence..... | 1 |
| Attn: Dr. A. F. Giacco..... | 1 |
| Attn: Dr. Julius Roth..... | 1 |
| Carnegie Institute of Technology, Schenley Park, Pittsburgh 13, Pa. Via: ONR Attn: Prof. E. M. Pugh..... | 2 |
| California Institute of Technology, Pasadena 4, Calif. Attn: Prof. Norman Davidson, Via: ONR..... | 1 |

CONFIDENTIAL

CONFIDENTIAL
NAVORD Report 4197

DISTRIBUTION LIST (CONT.)

| | No. of Copies |
|--|------------------|
| Arthur D. Little, Inc., Cambridge, Mass. | |
| Via: InaMat, | |
| Attn: Dr. E. L. Kreidl..... | 2 |
| Attn: Mr. Lee Ashton..... | 1 |
| Attn: Mr. A. R. Almeida..... | 1 |
| Sandia Corp., Albuquerque, New Mexico, Via: InaMat | |
| Attn: Mr. Frank Goss..... | 2 |
| Attn: Mr. C. F. Bild..... | 1 |
| ASTIA, Dayton, Ohio..... | 5 |

CONFIDENTIAL