

UNCLASSIFIED

AD NUMBER

AD092660

CLASSIFICATION CHANGES

TO: unclassified

FROM: confidential

LIMITATION CHANGES

TO:
Approved for public release, distribution unlimited

FROM:
Distribution authorized to U.S. Gov't. agencies and their contractors; Administrative/Operational Use; 20 APR 1956. Other requests shall be referred to National Aeronautics and Space Administration, Washington, DC.

AUTHORITY

NASA TR Server Website; NASA TR Server Website

THIS PAGE IS UNCLASSIFIED

CONFIDENTIAL

92660

Armed Services Technical Information Agency

Reproduced by

DOCUMENT SERVICE CENTER

KNOTT BUILDING, DAYTON, 2, OHIO

This document is the property of the United States Government. It is furnished for the duration of the contract and shall be returned when no longer required, or upon recall by ASTIA at the following address: Armed Services Technical Information Agency, Document Service Center, Knott Building, Dayton 2, Ohio.

NOTICE: WHEN GOVERNMENT OR OTHER DRAWINGS, SPECIFICATIONS OR OTHER DATA IS USED FOR ANY PURPOSE OTHER THAN IN CONNECTION WITH A DEFINITELY RELATED GOVERNMENT PROCUREMENT OPERATION, THE U. S. GOVERNMENT THEREBY INCURS NO RESPONSIBILITY, NOR ANY OBLIGATION WHATSOEVER; AND THE FACT THAT THE GOVERNMENT MAY HAVE FORMULATED, FURNISHED, OR IN ANY WAY SUPPLIED THE SAID DRAWINGS, SPECIFICATIONS, OR OTHER DATA IS NOT TO BE REGARDED BY ANY PERSON OR CORPORATION, OR CONVEYING ANY RIGHTS OR PERMISSION TO MANUFACTURE, REPRODUCE OR SELL ANY PATENTED INVENTION THAT MAY IN ANY WAY BE RELATED THERETO.

CONFIDENTIAL

CONFIDENTIAL

Copy 27

RM A56B03

NACA RM A56B03

92660

POSTAL FILE COPY



RESEARCH MEMORANDUM

PRESSURE DISTRIBUTIONS AT MACH NUMBERS OF 1.6 AND 1.9 OF
A CONICALLY CAMBERED WING OF TRIANGULAR PLAN FORM
WITH AND WITHOUT PYLON-MOUNTED ENGINE NACELLES

By E. Ray Phelps

Ames Aeronautical Laboratory
Moffett Field, Calif.

FC

CLASSIFIED DOCUMENT

This material contains information affecting the National Defense of the United States within the meaning of the espionage laws, Title 18, U.S.C., Secs. 793 and 794, the transmission or revelation of which in any manner to an unauthorized person is prohibited by law.

NATIONAL ADVISORY COMMITTEE FOR AERONAUTICS

WASHINGTON

April 20, 1956

CONFIDENTIAL

MAY 1956

6/11

63-94

NATIONAL ADVISORY COMMITTEE FOR AERONAUTICS

RESEARCH MEMORANDUM

PRESSURE DISTRIBUTIONS AT MACH NUMBERS OF 1.6 AND 1.9 OF
A CONICALLY CAMBERED WING OF TRIANGULAR PLAN FORM
WITH AND WITHOUT PYLON-MOUNTED ENGINE NACELLES

By E. Ray Phelps

SUMMARY

The results of an experimental investigation to determine the pressure-distribution characteristics of a conically cambered wing with and without pylon-mounted engine nacelles are presented for Mach numbers of 1.6 and 1.9. Wing airfoil sections in the streamwise direction were composed of NACA 0004.08-63 sections symmetrically distributed about a cambered surface conical about the wing apex. Pressure data are presented for nominal angles of attack of -2° , 0° , 4° , and 8° for a Reynolds number of 2.9 million for a Mach number of 1.6, and 2.6 million for a Mach number of 1.9.

The pressure data obtained during this investigation indicate that the low-pressure region existing on the upper surface over the forward part of the wing was spread over a larger proportion of the local chord than would be the case for an uncambered wing. It could be expected, therefore, that a reduced value of drag due to lift would be realized as a result of the camber.

The addition of the engine nacelles beneath the wing created large pressure changes on the wing, particularly on the lower surface, which were reflected in the chordwise and spanwise distribution of load. These effects resulted in a net increase of lift carried by the wing and an inboard shift of the spanwise location of the center of pressure.

INTRODUCTION

The pressure-distribution characteristics of airplane wings with externally mounted nacelles or stores are exceedingly difficult to predict with satisfactory accuracy while it has become increasingly important

CONFIDENTIAL

61 2293

with the advent of thin wings to have an accurate knowledge of the load distribution. An experimental investigation of a model of an airplane with external engine nacelles was recently conducted in the Ames 6- by 6-foot supersonic wind tunnel to provide information on this subject. The results of pressure measurements on the wing of the model, both with and without the nacelles, are published herewith without detailed analysis.

NOTATION

Free-stream conditions:

- M Mach number
 q_0 dynamic pressure, lb/sq in.
 P_0 static pressure, lb/sq in.

Wing geometry:

- b span, in.
c local chord, in.
 c_{av} average chord, in.
 α angle of attack of wing root chord, deg
x chordwise distance from leading edge of local chord, in.
y lateral distance from wing root chord, in.
z perpendicular distance from wing chord plane, in.

Pressure data:

- p local static pressure, lb/sq in.
 $\frac{c_{n_c}}{c_{av}}$ span loading coefficient, $\int_0^c \left(\frac{P_l - P_u}{c_{av}} \right) dx$

Subscripts

- u conditions on wing upper surface
l conditions on wing lower surface

APPARATUS AND EQUIPMENT

Wind Tunnel

The investigation reported herein was conducted in the Ames 6- by 6-foot supersonic wind tunnel, which is of the closed throat, variable pressure type. Further information regarding this facility can be found in reference 1.

Model

The model used for this investigation represents a four-engined, bomber-type airplane having a slender, indented body with a cambered, low-aspect-ratio triangular wing and a sweptback vertical tail (see figs. 1 and 2). As shown in figure 3, the model wing was liberally instrumented with static-pressure orifices on the upper right and lower left wing surfaces and to a lesser degree on the lower right and upper left wing surfaces. Support in the wind tunnel was provided by a sting which was an integral extension of the afterbody.

The wing utilized on the model was of triangular plan form having the leading edges swept back 60° and the trailing edges swept forward 10° , providing an aspect ratio of 2.3. The wing was mounted on the body with 3° incidence. Airfoil sections in the streamwise direction were composed of NACA 0004.08-63 sections symmetrically distributed about a cambered surface derived from a modification of the method suggested in reference 2 and expanded in reference 3. In reference 2, a cambered shape is derived which should support a nearly elliptic span load distribution at the design conditions. The derived shape was cambered outboard of 80 percent of the local semispan but, for structural reasons, the cambered portion of the wing of the present investigation was limited to the area outboard of 85 percent of the local semispan. The resultant cambered shape was conical about the wing apex and planar inboard of 85 percent of the local semispan. Ordinates of the cambered surface are given in table I.

Ducted engine nacelles were mounted on removable pylons beneath the wing as shown in figure 2. Also shown are the elevons, which remained undeflected during the present investigation, and the landing gear fairings, which protruded above and below the wing contour.

DATA REDUCTION

The local static pressures existing on the model wing were transmitted outside the test section by pressure tubing and introduced into one side of differential pressure transducers. The opposite side of each transducer diaphragm was subjected to a common reference pressure which was maintained nearly constant at a value midway between the maximum and minimum expected model static pressures. The electrical output of each transducer was then digitalized and recorded. The wind-tunnel total pressure was measured separately by two additional differential pressure transducers and recorded similarly. Measurement of the absolute pressure of the reference supply was performed by two absolute pressure transducers. From these measured data, the pressure coefficients presented herein were calculated.

TESTS AND PRECISION

Pressure-distribution measurements were obtained at several spanwise stations on the upper and lower surfaces of the model wing, both with and without engine nacelles. Tests were conducted at nominal angles of attack of -2° , 0° , 4° , and 8° for Mach numbers of 1.6 and 1.9. The Reynolds numbers of the tests, based upon the wing mean aerodynamic chord, were 2.9 million for $M = 1.6$ and 2.6 million for $M = 1.9$.

Each of the pressure measurements, that is, total pressure, reference pressure, and wing local pressures, is estimated to be accurate within about 1-1/2 percent of the dynamic pressure. Since these three separate measurements were involved in the calculation of each pressure coefficient, the mean measurement error was calculated by the root mean square method to be about 2-1/2 percent of the dynamic pressure. Although this may represent the error in absolute pressure magnitude, inspection of the data indicates that the distribution of pressure along any chord is considerably more accurate. This might be expected since fixed values of two of the variables, total pressure and reference pressure, were usually used for calculation of the pressure coefficients existing along any chord.

In addition, the pressure measurements on the wing are subject to an error caused by stream angularities and stream ambient pressure gradients. The model was tested with the wings in a vertical plane since it has been shown in reference 1 and some unpublished work that there is little flow angularity in horizontal planes (the pitch plane of the model). There are, however, ambient static-pressure gradients in the vertical plane as large as 4 percent of the dynamic pressure. Since these gradients do not change abruptly in the longitudinal direction, they probably do not mask any local flow phenomenon.

The angle of attack of the model with respect to the tunnel center line is estimated to be accurate within 0.1° .

RESULTS AND DISCUSSION

To permit a more graphic presentation of the results of this investigation, it was desirable to select representative data which would show the upper and lower surface pressure distributions at equivalent spanwise locations. With the instrumentation provided on the model, however, this was possible only by combining the pressure distributions measured on the left- and right-hand wing panels. This has been done in the graphical results presented herein for nominal angles of attack of 0° , 4° , and 8° . The pressures measured on the lower left and upper right wing panels have been plotted on a plan view of the right wing panel at all common spanwise locations. A tabulation of the measured pressure coefficients is presented in tables II and III.

Pressure Distribution

Without nacelles.- An examination of the pressure distributions shown in figure 4 for the model without nacelles at $M = 1.6$ indicates that the highly localized low-pressure peaks characteristic of the flow over the leading edges of uncambered wings have been reduced in magnitude and distributed over a larger percent of the local chord by the effects of the conical camber. This redistribution of the low-pressure region over a greater area on the cambered wing should permit attainment of higher leading-edge suction forces, and hence a lower drag due to lift, than that for uncambered wings.

Although not proved conclusively, there are indications in figure 4(c) of the presence of a shock wave on the upper surface of the wing, particularly at the 34-percent-semispan station, for an angle of attack of 8.5° . Shock waves of this nature have been reported in references 4 and 5 for uncambered wings having similar ratios of leading-edge sweep to Mach line sweep. The effects of Reynolds number were not investigated during the present tests, but it was shown in reference 5 that an increase in Reynolds number delayed the formation of such a shock wave to higher angles of attack.

On the lower surface of the wing, figure 4(a) shows an expansion region near the leading edge at an angle of attack of -0.1° for a Mach number of 1.6. This region of low pressures is most evident where the camber is greatest, that is, near the wing tip. As an example, the lower surface pressures measured at the 85.6-percent-semispan station indicate

the presence of a localized expansion, of the type reported in reference 6, over the forward 5 percent of the local chord terminated by a shock wave. Following this weak shock wave, a region of separated flow apparently exists aft to about 45 percent of the local chord where a strong shock wave stands.

The influence of the body is noticeable principally at the most inboard station, see figure 4, which was near the wing-body juncture. Actually the spanwise locations of the orifices varied as can be seen in figure 3, but the data have been plotted on a streamwise axis which was located visually as a good average location for all the orifices, both upper and lower. The wing-body fillet, which was quite generous near the wing trailing edge, was designed to fair into the elevon with the elevon deflected upward 30°. The upward sweep, with respect to the wing chord plane, of the trailing edge of the fillet probably caused the compression on the upper surface of the wing and the expansion on the lower surface which can be seen aft of about 85 percent of the local chord. An expansion on the upper surface between 60 and 85 percent of the local chord was probably caused by the indented portion of the body.

Through necessity, the landing gear fairings were in place for all the tests. Their effects upon the wing pressure distributions are difficult to isolate but are believed to be small. The pressure variations near the elevon hinge line are likely to be the result of the gap and possible misalignment of the elevon.

At $M = 1.9$, the data of figure 5 show that the pressure distributions measured on the wing without nacelles are generally similar to those measured for $M = 1.6$.

With nacelles.- The addition of the nacelles beneath the wing can be seen, from comparisons of figures 6 and 7 with figures 4 and 5, to have produced large changes in the distribution of pressure on the lower surface of the wing at Mach numbers of 1.6 and 1.9. The pressure distributions measured on the upper surface of the wing were relatively unchanged by the addition of the nacelles.

Large chordwise pressure gradients in the vicinity of the inboard nacelle afterbody can be seen, in figures 6 and 7, to have existed at each of the test Mach numbers. In particular, a region of pressures higher than those measured for the wing without nacelles existed at the 34-percent-semispan station in the proximity of the nacelle afterbody. These pressures increased in magnitude with increasing angle of attack. Near the base of the nacelle an expansion occurred, followed by an abrupt compression. After the latter compression, the flow smoothly expanded in the chordwise direction.

The flow field midway between the inboard and outboard nacelles was very complex because of the proximity of each of the nacelles. At the 58-percent-semispan station, for instance, a series of very abrupt pressure changes existed throughout the angle-of-attack range for each of the test Mach numbers. These pressure changes are probably a result of the exit shocks from the inboard nacelle, the inlet shocks from the outboard nacelle, and the oblique wave from the supporting pylon of the outboard nacelle.

LOADING

Since large pressure differences have been shown to exist on the wing due to the presence of the nacelles, it is of interest to determine the effects of the nacelles upon the spanwise load distribution. Figure 8 shows the spanwise variation of loading coefficients for the wing with nacelles compared to that for the wing without nacelles for the two test Mach numbers. The curves for the wing without nacelles were obtained by averaging the integrated chordwise pressure distributions measured on the left and right wing panels, thus largely eliminating the effects of stream asymmetries. The curves for the wing with nacelles were obtained by the addition of the measured increments of loading coefficients due to the presence of the nacelles to the average loadings obtained without nacelles.

For a Mach number of 1.6, figure 8(a) indicates that the presence of the engine nacelles beneath the wing creates rather large changes in the span load distribution. The net result was an increase of the total lift carried by the wing and an inboard shift of the spanwise location of the center of pressure at 4.2° and 8.5° angles of attack. For a Mach number of 1.9, figure 8(b) shows incremental loadings due to the nacelles similar to those measured for a Mach number of 1.6.

CONCLUDING REMARKS

Results of the pressure distribution investigation of a conically cambered, triangular wing of aspect ratio 2.3, both with and without pylon-mounted engine nacelles, may be summarized as follows:

1. A smooth expansion on the upper surface occurred near the leading edge at wing angles of attack from about -2.2° to 8.5° in contrast to the concentrated high negative pressures which are characteristic of uncambered wings.

2. Near zero angle of attack, a localized expansion occurred on the lower surface very near the leading edge, similar to that usually found on the upper surface of uncambered wings at angle of attack. This expansion disappeared with increasing angle of attack.

3. The addition of the nacelles beneath the wing caused large changes in the pressure distributions measured on the lower wing surface. The upper surface was affected to a much lesser degree.

4. The net effect upon the span load distribution of the addition of the nacelles was an increase of total lift carried by the wing and an inboard shift of the spanwise center of pressure for angles of attack of approximately 4° and 8° .

Ames Aeronautical Laboratory
National Advisory Committee for Aeronautics
Moffett Field, Calif., Feb. 3, 1956

REFERENCES

1. Frick, Charles W., and Olson, Robert N.: Flow Studies in the Asymmetric Adjustable Nozzle of the Ames 6- by 6-Foot Supersonic Wind Tunnel. NACA RM A9E24, 1949.
2. Hall, Charles F.: Lift, Drag, and Pitching Moment of Low-Aspect-Ratio Wings at Subsonic and Supersonic Speeds. NACA RM A53A30, 1953.
3. Boyd, John W., Migotsky, Eugene, and Wetzell, Benton E.: A Study of Conical Camber for Triangular and Sweptback Wings. NACA RM A55G19, 1955.
4. Hatch, John E., Jr., and Hargrave, L. Keith: Effects of Reynolds Number on the Aerodynamic Characteristics of a Delta Wing at Mach Number 2.41. NACA RM L51H06, 1951.
5. Hatch, John E., Jr., and Gallagher, James J.: Aerodynamic Characteristics of a 68.4° Delta Wing at Mach Numbers of 1.6 and 1.9 Over a Wide Reynolds Number Range. NACA RM L53I08, 1953.
6. Boyd, John W., and Phelps, E. Ray: A Comparison of the Experimental and Theoretical Loading Over Triangular Wings at Supersonic Speeds. NACA RM A50J17, 1951.

TABLE I.- COORDINATES OF CAMBERED SURFACE

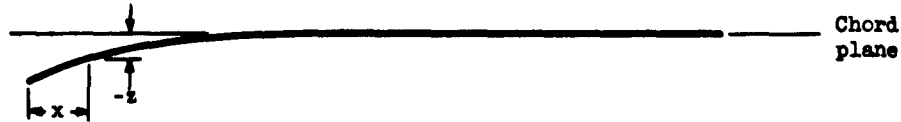

Span station 3.324 in.		Span station 5.290 in.		Span station 8.088 in.		Span station 9.176 in.		Span station 10.588 in.	
x	-z	x	-z	x	-z	x	-z	x	-z
0	0.095	0	0.151	0	0.231	0	0.262	0	0.303
.058	.077	.093	.122	.141	.187	.161	.212	.185	.245
.118	.065	.187	.104	.286	.158	.324	.180	.374	.207
.178	.055	.284	.088	.433	.135	.492	.153	.567	.176
.240	.047	.382	.075	.584	.114	.662	.130	.764	.149
.303	.039	.483	.063	.737	.096	.837	.109	.965	.126
.367	.033	.585	.052	.894	.080	1.014	.090	1.171	.104
.433	.027	.690	.042	1.054	.065	1.196	.073	1.380	.085
.501	.021	.797	.034	1.218	.051	1.382	.058	1.595	.067
.569	.016	.907	.026	1.385	.040	1.572	.045	1.814	.052
.640	.012	1.019	.019	1.557	.029	1.766	.033	2.038	.038
.712	.008	1.133	.013	1.731	.020	1.964	.022	2.267	.026
.785	.005	1.250	.008	1.910	.012	2.167	.013	2.501	.015
.860	.002	1.370	.004	2.093	.005	2.375	.006	2.740	.007
.937	.001	1.493	.001	2.281	.001	2.587	.002	2.985	.002
1.016	0	1.618	0	2.472	0	2.805	0	3.236	0
31.941	0	28.187	0	22.864	0	20.796	0	18.077	0

Span station 12.971 in.		Span station 16.000 in.		Span station 17.000 in.		Span station 18.062 in.		Span station 19.000 in.		Span station 19.500 in.	
x	-z	x	-z	x	-z	x	-z	x	-z	x	-z
0	0.371	0	0.457	0	0.486	0	0.516	0	0.547	0	0.557
.227	.300	.200	.390	.297	.393	.316	.417	.332	.439	.341	.451
.459	.254	.566	.314	.601	.333	.638	.354	.672	.372	.689	.382
.695	.216	.857	.266	.911	.283	.968	.301	1.018	.316	1.045	.325
.936	.183	1.155	.226	1.227	.240	1.304	.255	1.371	.268	1.088	.318
1.182	.154	1.459	.190	1.550	.202	1.647	.214	1.732	.225		
1.434	.128	1.769	.158	1.879	.167	1.997	.178	2.042	.192		
1.691	.104	2.086	.128	2.216	.136	2.355	.144				
1.954	.083	2.410	.102	2.561	.108	2.720	.115				
2.222	.064	2.741	.079	2.912	.084	3.094	.088				
2.496	.046	3.079	.057	3.272	.061	3.476	.064				
2.777	.031	3.425	.039	3.639	.041	3.830	.045				
3.064	.019	3.779	.023	4.016	.024						
3.367	.009	4.141	.011	4.400	.012						
3.657	.002	4.511	.003	4.793	.003						
3.965	0	4.890	0	5.146	0						
13.519	0	7.774	0	5.860	0						

TABLE II.- EXPERIMENTAL PRESSURE COEFFICIENTS; M = 1.6
(a) Upper surface, left wing panel

y/c	x/c	Without nacelles				With nacelles			
		$\alpha = -2.2^\circ$	$\alpha = -0.1^\circ$	$\alpha = 4.2^\circ$	$\alpha = 8.5^\circ$	$\alpha = -2.2^\circ$	$\alpha = -0.1^\circ$	$\alpha = 4.2^\circ$	$\alpha = 8.5^\circ$
0.897	0.000	0.155	0.175	0.198	-0.063	0.129	0.155	0.196	0.192
	0.050	0.202	0.173	0.106	-0.002	0.194	0.172	0.141	0.099
	0.100	0.251	0.177	0.041	-0.152	0.242	0.178	0.072	-0.041
	0.200	0.178	0.091	-0.045	-0.204	0.174	0.092	-0.023	-0.135
	0.300	0.117	0.021	-0.125	-0.271	0.119	0.030	-0.090	-0.195
	0.400	0.099	0.000	-0.148	-0.285	0.109	0.014	-0.115	-0.209
	0.800	0.000	-0.085	-0.244	-0.342	0.017	-0.078	-0.212	-0.289
0.807	0.634	0.021	-0.051	-0.276	-0.357	-0.001	-0.081	-0.226	-0.296
	0.707	0.000	-0.059	-0.291	-0.355	-0.022	-0.098	-0.273	-0.351
	0.800	0.014	-0.037	-0.268	-0.326	-0.015	-0.078	-0.261	-0.357
	0.900	0.024	-0.021	-0.238	-0.320	0.000	-0.051	-0.238	-0.327
0.645	0.000	-0.233	-0.135	0.276	0.433	-0.159	-0.053	0.243	0.464
	0.029	0.279	0.213	0.061	-0.142	0.346	0.263	0.108	-0.083
	0.079	0.158	0.082	-0.056	-0.202	0.199	0.098	-0.042	-0.178
	0.154	0.066	-0.039	-0.177	-0.289	0.071	-0.052	-0.181	-0.287
	0.292	0.020	-0.060	-0.266	-0.314	0.041	-0.049	-0.248	-0.319
	0.404	0.029	-0.023	-0.245	-0.329	0.054	-0.013	-0.232	-0.310
	0.504	0.059	0.011	-0.160	-0.320	0.054	-0.036	-0.135	-0.313
	0.604	0.042	-0.003	-0.078	-0.291	0.022	-0.018	-0.079	-0.302
	0.729	0.068	0.023	-0.063	-0.212	0.030	-	-0.072	-0.199
	0.457	0.000	0.132	0.219	0.369	0.355	0.162	0.227	0.341
0.028		0.248	0.178	0.009	-0.152	0.227	0.149	0.030	-0.088
0.050		0.157	0.082	-0.068	-0.206	0.125	0.052	-0.066	-0.176
0.099		0.047	-0.036	-0.215	-0.316	0.078	0.042	-0.096	-0.178
0.149		0.034	-0.044	-0.225	-0.315	0.032	-0.061	-0.255	-0.348
0.502		-0.010	-0.008	-0.013	-0.027	0.060	0.051	-0.063	-0.079
0.602		0.064	0.018	-0.058	-0.167	0.104	0.054	-0.019	-0.079
0.677		0.061	0.019	-0.058	-0.151	0.097	0.048	-0.027	-0.090
0.752		0.062	0.031	-0.046	-0.109	0.097	0.053	-0.014	-0.059
0.814		0.051	0.037	-0.015	-0.074	0.043	-0.006	-0.051	-0.102
0.825		0.049	0.031	-0.033	-0.076	0.027	-0.006	-0.065	-0.117
0.850		0.023	-0.005	-0.064	-0.109	0.012	-0.019	-0.073	-0.122
0.875		0.024	-0.002	-0.061	-0.108	0.000	-0.033	-0.087	-0.148
0.900		0.042	0.010	-0.048	-0.092	0.007	-0.024	-0.078	-0.126
0.950		0.020	-0.013	-0.075	-0.110	0.004	-0.007	-0.044	-0.099
0.234	0.839	0.040	0.033	-0.000	-0.030	0.085	0.063	0.027	-0.006
	0.850	0.034	0.004	-0.041	0.089	0.074	0.043	-0.002	-0.049
	0.875	0.032	0.007	-0.043	-0.099	0.051	0.019	-0.034	-0.083
	0.900	0.030	0.005	-0.044	-0.107	0.049	0.014	-0.038	-0.085
	0.925	-0.002	-0.023	-0.076	-0.129	0.050	0.022	-0.028	-0.083
	0.970	0.022	0.004	-0.052	-0.099	0.016	-0.005	-0.051	-0.097
0.156	0.900	0.033	0.011	-0.032	-0.082	0.045	0.012	-0.038	-0.078
	0.925	0.021	-0.004	-0.040	-0.099	0.017	-0.008	-0.053	-0.124
	0.950	-0.071	-0.079	-0.108	-0.173	-0.070	-0.074	-0.093	-0.166
	0.970	-0.052	-0.054	-0.088	-0.138	-0.045	-0.048	-0.069	-0.124

TABLE II.- EXPERIMENTAL PRESSURE COEFFICIENTS; M = 1.6 - Continued
(b) Lower surface, left wing panel

$\frac{z}{b}$	x/c	Without nacelles				With nacelles			
		$\alpha = -2.2^\circ$	$\alpha = -0.1^\circ$	$\alpha = 4.2^\circ$	$\alpha = 8.5^\circ$	$\alpha = -2.2^\circ$	$\alpha = -0.1^\circ$	$\alpha = 4.2^\circ$	$\alpha = 8.5^\circ$
0.856	0.000	-0.243	-0.208	0.080	0.244	-0.245	-0.159	0.005	0.525
	0.050	-0.286	-0.295	-0.038	0.262	-0.353	-0.347	-0.187	0.073
	0.100	-0.274	-0.218	0.007	0.244	-0.305	-0.223	-0.083	0.127
	0.200	-0.258	-0.240	0.085	0.234	-0.298	-0.190	-0.023	0.217
	0.300	-0.265	-0.250	0.100	0.233	-0.253	-0.190	-0.021	0.239
	0.400	-0.261	-0.235	0.104	0.226	-0.171	-0.156	0.007	0.252
	0.525	-0.256	-0.065	0.103	0.217	-0.157	-0.128	0.105	0.364
	0.700	-0.117	0.028	0.109	0.244	-	-	-	-
0.580	0.000	-	-	-	-	0.292	0.370	0.486	0.531
	0.015	-0.270	-0.152	0.134	0.368	-0.211	-0.146	0.039	0.320
	0.050	-0.286	-0.107	0.163	0.319	-0.187	-0.114	0.091	0.422
	0.075	-0.261	-0.097	0.167	0.300	-0.166	-0.073	0.240	0.522
	0.100	-0.274	-0.143	0.140	0.251	-0.129	0.003	0.313	0.413
	0.200	-0.145	-0.006	0.123	0.223	-0.147	-0.052	0.039	0.207
	0.300	-0.051	0.036	0.117	0.222	-0.176	-0.114	0.231	0.392
	0.392	-0.042	-0.017	0.074	0.189	-0.081	0.029	0.165	0.286
	0.500	-0.041	-0.009	0.081	0.189	-0.110	-0.041	0.085	0.444
	0.600	-0.043	-0.021	0.048	0.121	-0.147	-0.083	0.141	0.250
	0.700	-0.047	-0.011	0.069	0.163	-0.190	-0.104	0.095	0.186
	0.756	-0.073	-0.036	0.041	0.125	-0.065	-0.075	0.044	0.139
	0.780	-0.013	0.034	0.102	0.191	-0.045	0.009	0.078	0.169
	0.800	-0.017	0.024	0.089	0.169	-0.078	-	0.044	0.125
	0.825	-0.009	0.029	0.089	0.174	-0.100	-	0.024	0.101
	0.850	-0.004	0.041	0.091	0.180	-0.098	-0.024	0.013	0.082
0.950	-0.041	-0.002	0.057	0.141	-0.054	-0.010	-0.006	0.040	
0.462	0.014	-0.288	-0.197	0.141	0.395	-0.289	-0.226	-0.056	0.101
	0.023	-0.275	-0.191	0.174	0.398	-0.287	-0.218	-0.032	0.108
	0.047	-0.332	-0.207	0.162	0.331	-0.296	-0.200	-0.001	0.122
	0.076	-0.157	0.071	0.222	0.378	-0.045	-0.008	0.067	0.163
	0.099	-0.038	0.121	0.247	0.367	-0.018	0.009	0.093	0.182
	0.206	0.034	0.088	0.176	0.280	-0.035	0.017	0.124	0.246
	0.252	-0.007	0.046	0.142	0.251	-0.070	-0.030	0.026	0.052
	0.306	-0.024	0.018	0.110	0.211	-0.189	-0.170	-0.073	0.362
	0.402	-0.003	0.037	0.130	0.238	0.092	0.125	0.205	0.242
	0.501	-0.005	0.029	0.113	0.218	0.016	0.066	0.154	0.248
	0.604	-0.017	0.017	0.096	0.196	0.011	0.057	0.150	0.348
	0.705	-0.019	0.010	0.086	0.178	-0.050	-0.007	0.112	0.260
	0.755	-0.035	-0.004	0.060	0.154	-0.096	-0.058	0.105	0.171
	0.797	-0.033	-0.004	0.062	0.146	-0.143	-0.097	0.069	0.112
	0.813	-0.001	0.035	0.095	0.179	-0.112	-0.063	0.110	0.165
	0.856	-0.029	0.013	0.070	0.152	-0.118	-0.063	0.079	0.148
0.907	-0.039	0.001	0.058	0.138	-0.160	-0.115	0.003	0.076	
0.957	-0.072	-0.030	0.026	0.107	-0.108	-0.069	-0.015	0.042	
0.340	0.000	0.321	0.352	0.340	0.251	0.488	0.495	0.464	0.285
	0.015	-0.213	-0.058	0.168	0.329	-0.091	0.059	0.348	0.560
	0.028	-0.216	-0.052	0.138	0.283	-	-	-	-
	0.056	-0.205	-0.003	0.125	0.253	0.043	0.128	0.276	0.444
	0.075	-0.049	0.014	0.104	0.228	0.039	0.093	0.230	0.407
	0.100	-0.031	0.011	0.111	0.233	0.008	0.068	0.220	0.490
	0.150	-0.000	0.057	0.134	0.250	0.002	0.078	0.275	0.532
	0.250	-0.003	0.041	0.109	0.217	-0.236	-0.091	0.094	0.238
	0.306	-0.025	0.025	0.097	0.207	-0.162	-0.103	0.050	0.142
	0.400	-0.022	0.024	0.099	0.198	-0.069	-0.027	0.017	0.053
	0.500	-0.047	0.000	0.071	0.166	0.116	0.133	0.201	0.339
	0.600	-0.046	-0.002	0.064	0.151	0.083	0.105	0.170	0.289
	0.700	-0.054	-0.014	0.047	0.135	0.018	0.050	0.135	0.252
	0.812	-0.058	-0.016	0.043	0.130	-0.058	-0.019	0.062	0.183
	0.827	-0.014	0.027	0.082	0.157	-0.024	0.010	0.102	0.213
	0.850	-0.012	0.015	0.079	0.155	-0.090	-0.058	0.041	0.019
0.875	-0.069	-0.040	0.025	0.111	-0.117	-0.083	0.043	0.099	
0.900	-0.075	-0.048	0.018	0.102	-0.093	-0.056	0.023	0.124	
0.925	-0.057	-0.028	0.040	0.113	-0.079	-0.037	0.098	0.138	
0.950	-0.057	-0.028	0.029	0.110	-0.127	-0.080	0.034	0.084	
0.103	0.000	0.482	0.508	0.461	0.439	0.458	0.484	0.418	0.434
	0.015	0.052	0.106	0.229	0.274	0.014	0.077	0.196	0.254
0.104	0.025	0.036	0.086	0.198	0.259	0.012	0.074	0.181	0.247
	0.050	0.004	0.051	0.146	0.224	-0.054	0.009	0.091	0.182
0.103	0.100	-0.007	0.024	0.109	0.205	-0.024	0.034	0.100	0.204
	0.150	0.016	0.038	0.096	0.180	0.148	0.166	0.220	0.268
0.089	0.200	0.004	0.034	0.099	0.173	0.015	0.041	0.108	0.189
	0.250	0.028	0.059	0.126	0.219	0.050	0.078	0.168	0.283
0.076	0.300	0.028	0.059	0.116	0.214	0.028	0.062	0.133	0.209
	0.500	0.003	0.034	0.095	0.183	0.000	0.047	0.163	0.313
0.062	0.700	0.009	0.046	0.111	0.189	-0.136	-0.072	0.005	0.038
	0.555	0.750	0.014	0.040	0.108	0.187	-0.112	0.007	0.128
0.052	0.950	-0.082	-0.047	0.000	0.059	-0.003	0.010	0.070	0.185

TABLE II.- EXPERIMENTAL PRESSURE COEFFICIENTS; M = 1.6 - Continued
(c) Upper surface, right wing panel

x/c	y/c	Without nacelles				With nacelles			
		$\alpha = -2.2^\circ$	$\alpha = -0.1^\circ$	$\alpha = 4.2^\circ$	$\alpha = 8.5^\circ$	$\alpha = -2.2^\circ$	$\alpha = -0.1^\circ$	$\alpha = 4.2^\circ$	$\alpha = 8.5^\circ$
0.856	0.000	-0.337	-0.316	-0.069	0.223	-0.238	-0.241	-0.274	-0.210
	0.050	0.200	0.162	0.033	-0.174	0.152	0.120	0.055	-0.036
	0.100	---	---	---	---	0.089	0.043	-0.037	-0.129
	0.200	0.038	-0.032	-0.169	-0.298	-0.020	-0.079	-0.175	-0.253
	0.409	-0.012	-0.091	-0.233	-0.343	-0.042	-0.105	-0.231	-0.297
	0.700	-0.086	-0.135	-0.268	-0.339	-0.033	-0.132	-0.246	-0.329
	0.900	-0.074	-0.151	-0.328	-0.368	-0.016	-0.095	-0.251	-0.323
	---	---	---	---	---	---	---	---	---
0.645	0.000	0.178	0.257	0.282	0.108	0.402	0.411	0.389	0.315
	0.756	0.002	-0.039	-0.133	-0.311	-0.001	-0.062	-0.228	-0.244
	0.777	0.007	-0.038	-0.109	-0.309	-0.007	-0.043	-0.101	-0.222
	0.950	0.004	-0.039	-0.097	-0.272	-0.019	-0.047	-0.101	-0.251
0.580	0.000	0.081	0.210	0.381	0.384	0.011	0.099	0.268	0.417
	0.015	0.275	0.229	0.104	-0.090	0.263	0.231	0.151	0.055
	0.050	0.129	0.058	-0.081	-0.225	0.109	0.049	-0.053	-0.148
	0.075	0.071	-0.002	-0.137	-0.262	0.078	0.009	-0.110	-0.188
	0.105	0.009	-0.064	-0.209	-0.322	0.015	-0.059	-0.172	-0.250
	0.200	-0.006	-0.087	-0.275	-0.344	0.083	-0.035	-0.245	-0.333
	0.300	-0.005	-0.073	-0.246	-0.340	0.039	-0.048	-0.261	-0.369
	0.410	0.020	-0.028	-0.173	-0.325	0.038	-0.013	-0.156	-0.313
	0.500	---	---	---	---	0.047	0.005	-0.065	-0.279
	0.600	0.010	-0.036	-0.115	-0.229	0.040	0.004	-0.052	-0.244
	0.700	0.019	-0.033	-0.102	-0.256	0.013	-0.027	-0.094	-0.245
	0.756	0.001	-0.038	-0.107	-0.249	-0.009	-0.045	-0.108	-0.147
	0.779	0.030	-0.015	-0.100	-0.271	0.041	0.000	-0.061	-0.102
	0.800	---	---	---	---	0.012	-0.017	-0.075	-0.111
	0.825	0.017	-0.023	-0.085	-0.234	0.013	-0.002	-0.047	-0.084
	0.850	-0.003	-0.042	-0.110	-0.255	-0.022	-0.056	-0.109	-0.142
0.900	0.017	-0.016	-0.093	-0.244	-0.021	-0.052	-0.109	-0.092	
0.950	0.011	-0.022	-0.089	-0.231	-0.033	-0.062	-0.114	-0.164	
0.457	0.000	0.286	0.307	0.267	0.095	0.280	0.265	0.291	0.307
	0.015	0.285	0.220	0.082	-0.079	0.211	0.161	0.067	-0.023
	0.025	0.186	0.130	-0.026	-0.181	0.165	0.112	-0.002	-0.135
	0.050	0.130	0.058	-0.085	-0.208	0.077	0.023	-0.089	-0.193
	0.100	0.028	-0.043	-0.202	-0.303	-0.016	-0.088	-0.232	-0.326
	0.150	-0.021	-0.088	-0.277	-0.313	-0.035	-0.107	-0.249	-0.343
	0.205	-0.019	-0.083	-0.244	-0.346	0.007	-0.061	-0.231	-0.346
	0.315	-0.009	-0.016	-0.088	-0.222	0.024	0.008	-0.045	-0.210
0.340	0.000	0.162	0.241	0.333	0.324	0.338	0.397	0.434	0.325
	0.015	0.219	0.146	0.003	-0.151	0.248	0.168	0.001	-0.187
	0.025	0.139	0.068	-0.083	-0.223	0.171	0.078	-0.080	-0.218
	0.050	0.096	0.020	-0.032	-0.255	0.067	-0.014	-0.165	-0.283
	0.075	0.033	-0.032	-0.204	-0.335	0.041	-0.035	-0.213	-0.324
	0.100	0.019	-0.038	-0.176	-0.322	0.023	-0.044	-0.192	-0.323
	0.153	0.001	-0.041	-0.178	-0.321	0.012	-0.045	-0.216	-0.351
	0.250	0.024	-0.023	-0.089	-0.313	0.004	-0.025	-0.084	-0.255
	0.300	---	---	---	---	0.026	0.001	-0.064	-0.177
	0.400	0.036	0.000	-0.068	-0.111	0.029	-0.005	-0.073	-0.128
	0.500	0.041	0.000	-0.058	-0.114	0.044	0.011	-0.045	-0.099
	0.600	0.039	0.000	-0.066	-0.119	0.058	0.026	-0.032	-0.078
	0.697	0.036	-0.000	-0.055	-0.108	0.088	0.057	-0.008	-0.066
	0.810	0.017	-0.015	-0.068	-0.120	0.060	0.030	-0.022	-0.070
	0.827	0.029	-0.001	-0.063	-0.114	0.029	0.000	-0.060	-0.121
	0.850	0.007	-0.010	-0.066	-0.130	0.032	0.000	-0.059	-0.109
0.875	0.022	-0.000	-0.062	-0.111	0.021	-0.015	-0.071	-0.112	
0.900	0.036	0.006	-0.051	-0.105	0.048	0.017	-0.035	-0.078	
0.925	0.032	-0.001	-0.061	-0.107	0.033	-0.003	-0.064	-0.106	
0.950	-0.003	-0.030	-0.091	-0.137	0.021	-0.012	-0.075	-0.119	
0.234	0.000	0.186	0.261	0.375	0.355	0.249	0.309	0.375	0.320
	0.015	0.244	0.187	0.071	-0.047	0.263	0.183	0.042	-0.086
	0.034	0.141	0.070	-0.080	-0.199	0.143	0.052	-0.115	-0.241
	0.053	0.077	0.003	-0.156	-0.282	0.052	-0.034	-0.194	-0.314
	0.150	0.015	-0.023	-0.123	-0.248	0.023	-0.024	-0.134	-0.270
	0.300	0.015	0.027	-0.082	-0.131	0.057	0.005	-0.103	-0.163
	0.400	0.043	0.013	-0.059	-0.125	0.032	-0.006	-0.083	-0.150
	0.500	0.055	0.021	-0.042	-0.106	0.034	-0.005	-0.076	-0.157
	0.600	0.060	0.029	-0.035	-0.088	0.013	-0.023	-0.083	-0.138
	0.700	0.068	0.035	-0.022	-0.074	0.025	-0.009	-0.070	-0.124
	0.750	0.049	0.019	-0.041	-0.097	0.029	-0.003	-0.060	-0.105
	0.800	0.038	0.012	-0.047	-0.101	0.041	0.008	-0.046	-0.094
0.823	0.009	-0.012	-0.074	-0.123	0.044	0.013	-0.038	-0.091	
0.103	0.000	0.438	0.466	0.440	0.404	0.475	0.454	0.441	0.415
	0.015	0.276	0.211	0.086	-0.040	---	---	---	---
0.104	0.025	0.167	0.112	0.026	-0.063	0.181	0.189	0.037	-0.062
	0.050	0.106	0.066	-0.000	-0.074	0.068	0.027	-0.033	-0.107
	0.100	0.069	0.026	-0.055	-0.136	0.067	0.023	-0.062	-0.147
	0.150	0.030	0.016	-0.057	-0.119	0.016	-0.009	-0.061	-0.106
0.288	0.253	0.058	0.018	-0.038	-0.085	0.099	0.059	-0.011	
0.287	0.338	0.051	0.023	-0.029	-0.075	0.103	0.066	0.002	
0.286	0.398	0.093	0.054	-0.000	-0.050	0.122	0.086	0.023	
0.288	0.496	0.111	0.068	0.009	-0.044	0.140	0.102	0.036	
0.260	0.601	0.046	0.022	-0.018	-0.059	0.039	0.018	-0.012	
0.273	0.700	0.043	0.007	-0.044	-0.100	0.029	0.000	-0.053	
0.290	0.750	0.020	-0.010	-0.061	-0.111	0.000	-0.028	-0.072	
0.106	0.804	0.029	-0.008	-0.049	-0.102	0.034	0.013	-0.028	
0.128	0.849	0.067	0.034	-0.014	-0.070	0.115	0.083	0.039	
0.137	0.875	0.041	0.028	0.013	0.000	0.067	0.062	0.067	

TABLE II.- EXPERIMENTAL PRESSURE COEFFICIENTS; M = 1.6 - Concluded
(d) Lower surface, right wing panel

$\frac{y}{b}$	x/c	Without nacelles				With nacelles				
		$\alpha = -2.2^\circ$	$\alpha = -0.1^\circ$	$\alpha = 4.2^\circ$	$\alpha = 8.5^\circ$	$\alpha = -2.2^\circ$	$\alpha = -0.1^\circ$	$\alpha = 4.2^\circ$	$\alpha = 8.5^\circ$	
0.897	0.000	-0.370	-0.350	-0.088	0.042	-0.383	-0.368	-0.177	0.251	
	0.050	-0.362	-0.342	-0.092	0.224	-0.387	-0.374	-0.257	0.123	
	0.100	-0.360	-0.322	-0.074	0.209	-0.377	-0.357	-0.240	0.148	
	0.400	-0.313	-0.320	-0.038	0.154	-0.340	-0.344	-0.146	0.172	
	0.600	-0.069	-0.041	-0.025	-0.005	0.047	0.066	0.094	0.150	
0.645	0.025	-0.269	-0.195	0.092	0.288	-0.345	-0.304	-0.029	0.251	
	0.050	-0.311	-0.193	0.069	0.229	-0.353	-0.270	0.093	0.200	
	0.150	-0.251	-0.119	0.075	0.193	-0.302	0.013	0.089	0.341	
	0.300	-0.002	0.024	0.085	0.170	-0.051	-0.022	0.130	0.309	
	0.770	-0.082	-0.039	0.046	0.129	-0.165	-0.079	-0.045	0.051	
	0.800	-0.083	-0.041	0.035	0.126	-0.099	-0.074	-0.051	0.035	
	0.875	-0.079	-0.042	0.033	0.124	-0.031	-0.030	-0.015	0.025	
	0.940	-0.096	-0.062	0.007	0.095	-0.045	-0.028	-0.029	0.000	
	0.444	0.021	-0.269	-0.189	0.069	0.242	-0.161	-0.116	-0.008	0.110
		0.036	-0.282	-0.106	0.083	0.233	-0.183	-0.138	-0.054	0.038
0.060		-0.246	-0.069	0.082	0.215	-0.192	-0.156	-0.085	0.005	
0.079		-0.157	-0.019	0.102	0.230	-0.184	-0.150	-0.074	0.017	
0.099		-0.084	0.015	0.136	0.252	-0.143	-0.111	-0.024	0.070	
0.149		-0.060	0.011	0.096	0.192	-0.139	-0.098	-0.008	0.078	
0.194		-0.060	-0.005	0.071	0.179	-0.085	-0.037	0.041	0.149	
0.293		-0.083	-0.036	0.045	0.152	-0.159	-0.125	-0.072	-0.011	
0.601		-0.071	-0.028	0.035	0.128	0.012	0.062	0.148	0.280	
0.701		-0.074	-0.036	0.035	0.129	-0.023	0.010	0.102	0.258	
0.751		-0.071	-0.033	0.041	0.128	-0.050	-0.021	0.119	0.206	
0.792		-0.048	-0.013	0.059	0.138	-0.054	-0.024	0.135	0.188	
0.814		-0.027	-0.002	0.081	0.158	-0.043	-0.024	0.000	0.182	
0.850		-0.038	-0.006	0.066	0.142	-0.111	-0.070	0.061	0.115	
0.900		-0.039	-0.002	0.056	0.123	-0.167	-0.111	-0.000	0.062	
0.950		-0.055	-0.022	0.040	0.121	-0.153	-0.085	-0.001	0.050	
0.234		0.025	-0.097	0.015	0.156	0.281	-0.056	0.031	0.159	0.285
	0.050	-0.020	0.036	0.153	0.265	-0.032	0.026	0.149	0.291	
	0.075	-0.002	0.044	0.145	0.252	-0.033	0.025	0.138	0.253	
	0.100	-	-	-	-	-0.034	0.019	0.129	0.218	
	0.150	0.015	0.017	0.097	0.185	-0.027	-0.000	0.077	0.184	
	0.200	-0.034	0.001	0.083	0.183	0.033	0.091	0.137	0.342	
	0.300	-0.066	-0.033	0.041	0.137	-	-	-	-	
	0.400	-0.050	-0.007	0.053	0.137	-	-	-	-	
	0.500	-0.033	0.000	0.055	0.146	-0.049	-0.013	0.097	0.203	
	0.600	-0.066	-0.028	0.026	0.115	-0.123	-0.117	-0.004	0.128	
	0.700	-0.055	-0.016	0.033	0.120	-0.021	0.017	0.083	0.158	
	0.750	-	-	-	-	-0.058	-0.022	0.062	0.156	
	0.800	-0.041	-0.004	0.052	0.131	-0.056	-0.019	0.073	0.182	
	0.822	-0.032	0.000	0.060	0.133	-0.054	-0.020	0.052	0.147	
	0.839	-0.002	0.032	0.113	0.250	-0.027	-0.005	0.080	0.248	
	0.850	-0.044	-0.012	0.045	0.120	-0.045	-0.003	0.069	0.153	
	0.875	-0.060	-0.030	0.022	0.089	-0.077	-0.043	0.014	0.103	
0.900	-0.058	-0.021	0.031	0.110	-0.068	-0.034	0.031	0.155		
0.925	-0.060	-0.027	0.038	0.108	-0.066	-0.064	0.029	0.150		
0.970	-0.051	-0.017	0.035	0.098	-	-	-	-		
0.156	0.900	-0.078	-0.050	-0.004	0.068	-0.004	0.014	0.067	0.183	
	0.925	-0.095	-0.065	-0.017	0.056	0.000	0.014	0.073	0.180	
	0.950	-0.069	-0.037	0.012	0.082	-0.036	-0.020	0.042	0.136	
	0.970	-0.070	-0.029	0.000	0.076	-0.024	-0.011	0.083	0.129	

TABLE III.- EXPERIMENTAL PRESSURE COEFFICIENTS; M = 1.9
(a) Upper surface, left wing panel

$\frac{2y}{b}$	x/c	Without nacelles				With nacelles			
		$\alpha = -2.2^\circ$	$\alpha = -0.1^\circ$	$\alpha = 4.2^\circ$	$\alpha = 8.4^\circ$	$\alpha = -2.2^\circ$	$\alpha = -0.1^\circ$	$\alpha = 4.2^\circ$	$\alpha = 8.4^\circ$
0.897	0.000	0.375	0.398	0.428	0.399	0.367	0.385	0.433	0.470
	0.050	0.202	0.190	0.143	0.098	0.245	0.218	0.193	0.188
	0.100	0.250	0.216	0.126	-0.002	0.276	0.237	0.166	0.093
	0.200	0.183	0.137	0.051	-0.058	0.208	0.161	0.084	0.006
	0.300	0.115	0.068	-0.022	-0.126	0.149	0.097	0.019	-0.052
	0.400	0.094	0.045	-0.044	-0.141	0.133	0.080	-0.000	-0.069
0.800	-0.007	-0.052	-0.131	-0.203	0.031	-0.021	-0.087	-0.145	
0.807	0.634	0.001	-0.068	-0.130	-0.194	-0.013	-0.058	-0.111	-0.150
	0.707	-0.007	-0.078	-0.153	-0.217	-0.037	-0.094	-0.161	-0.210
	0.800	0.016	-0.059	-0.148	-0.212	-0.025	-0.089	-0.169	-0.223
	0.900	0.043	-0.043	-0.135	-0.201	-0.003	-0.066	-0.152	-0.202
	0.545	0.000	-0.109	-0.037	0.203	0.454	-0.104	-0.073	0.255
0.029	0.295	0.244	0.143	-0.004	0.443	0.374	0.233	0.093	
0.079	0.184	0.129	0.039	-0.074	0.257	0.188	0.069	-0.036	
0.154	0.070	0.009	-0.070	-0.157	0.085	0.024	-0.071	-0.144	
0.292	0.000	-0.066	-0.163	-0.234	0.022	-0.041	-0.140	-0.193	
0.404	0.011	-0.047	-0.169	-0.245	0.036	-0.019	-0.141	-0.199	
0.504	0.058	-0.004	-0.164	-0.244	0.088	-0.010	-0.124	-0.185	
0.604	0.045	0.001	-0.136	-0.229	0.016	-0.018	-0.143	-0.206	
0.749	0.081	0.045	-0.041	-0.173	0.037	0.007	-0.084	-0.177	
0.457	0.000	0.153	0.241	0.344	0.355	0.136	0.207	0.323	0.433
	0.028	0.211	0.181	0.063	-0.065	0.213	0.189	0.111	0.026
	0.050	0.157	0.094	-0.003	-0.109	0.127	0.084	0.000	-0.078
	0.099	0.057	-0.014	-0.121	-0.197	0.090	0.100	0.011	-0.051
	0.149	0.025	-0.037	-0.164	-0.242	0.017	-0.044	-0.166	-0.221
	0.502	0.002	0.000	-0.000	-0.010	0.071	0.065	0.079	0.085
	0.602	0.056	0.019	-0.033	-0.117	0.107	0.072	.008	-0.078
	0.677	0.049	0.016	-0.039	-0.104	0.095	0.056	-0.004	-0.077
	0.752	0.054	0.025	-0.036	-0.093	0.120	0.081	0.021	-0.061
	0.814	0.078	0.052	-0.005	-0.057	0.079	0.049	-0.009	-0.080
	0.825	0.076	0.043	-0.003	-0.058	0.067	0.035	-0.019	-0.081
	0.850	0.042	0.005	-0.045	-0.093	0.057	0.033	-0.086	-0.096
	0.875	0.043	0.008	-0.044	-0.097	0.048	0.022	-0.032	-0.097
	0.900	0.061	-0.026	-0.025	-0.076	0.048	0.023	-0.030	-0.093
0.950	0.026	-0.001	-0.053	-0.099	0.047	0.030	-0.011	-0.064	
0.234	0.839	0.118	0.035	0.008	-0.026	0.096	0.087	0.051	0.013
	0.850	0.050	0.016	-0.022	-0.058	0.091	0.079	0.034	-0.005
	0.875	0.042	0.012	-0.028	-0.073	0.073	-0.069	-0.002	-0.053
	0.900	0.057	0.025	-0.020	-0.069	0.083	0.062	.008	-0.038
	0.925	0.022	-0.004	-0.047	-0.094	0.093	0.074	0.025	-0.025
	0.970	0.048	0.022	-0.021	-0.065	0.062	0.045	0.001	-0.045
0.156	0.900	0.062	0.030	-0.007	-0.047	0.063	0.048	.006	-0.036
	0.925	0.048	0.034	-0.003	-0.054	0.035	0.016	-0.019	-0.059
	0.950	-0.033	-0.051	-0.069	-0.119	-0.009	-0.020	-0.040	-0.083
	0.970	-0.019	-0.029	-0.053	-0.092	-0.002	-0.007	-0.023	-0.053

TABLE III.- EXPERIMENTAL PRESSURE COEFFICIENTS; M = 1.9 - Continued
(b) Lower surface, left wing panel

$\frac{2y}{b}$	x/c	Without nacelles				With nacelles			
		$\alpha = -2.2^\circ$	$\alpha = -0.1^\circ$	$\alpha = 4.2^\circ$	$\alpha = 8.4^\circ$	$\alpha = -2.2^\circ$	$\alpha = -0.1^\circ$	$\alpha = 4.2^\circ$	$\alpha = 8.4^\circ$
0.856	0.000	-0.141	-0.100	0.076	0.389	-0.125	-0.083	0.014	0.281
	0.050	-0.271	-0.241	-0.018	0.216	-0.215	-0.208	-0.142	-0.001
	0.100	-0.264	-0.249	-0.002	0.218	-0.190	-0.159	-0.070	0.057
	0.200	-0.235	-0.164	0.011	0.217	-0.164	-0.132	-0.030	0.107
	0.300	-0.234	-0.141	0.070	0.214	-0.167	-0.144	-0.038	0.119
	0.400	-0.225	-0.093	0.099	0.210	-0.115	-0.114	-0.013	0.169
	0.525	-0.209	-0.060	0.088	0.201	-0.081	-0.073	0.021	0.272
	0.700	-0.043	0.059	0.091	0.237	-	-	-	-
	0.580	0.000	-	-	-	0.346	0.417	0.515	0.555
0.015	-0.196	-0.137	0.086	0.324	-0.124	-0.107	-0.015	0.155	
0.050	-0.205	-0.139	0.120	0.304	-0.128	-0.079	0.037	0.241	
0.075	-0.216	-0.090	0.129	0.281	-0.134	-0.078	0.050	0.249	
0.100	-0.211	-0.063	0.145	0.237	-0.153	-0.101	0.051	0.251	
0.200	-0.041	0.028	0.135	0.211	-0.067	0.029	0.216	0.220	
0.300	-0.009	0.032	0.114	0.204	-0.057	0.031	0.057	0.311	
0.392	-0.041	-0.007	0.069	0.172	-0.054	0.014	0.130	0.317	
0.500	-0.043	-0.008	0.077	0.155	-0.074	0.010	0.151	0.274	
0.600	-0.052	-0.020	0.049	0.106	-0.094	-0.036	0.098	0.282	
0.700	-0.041	-0.002	0.073	0.146	-0.134	-0.058	0.073	0.218	
0.756	-0.062	-0.026	0.043	0.123	-0.149	-0.100	0.061	0.176	
0.780	-0.000	0.039	0.110	0.190	-0.114	-0.083	0.101	0.211	
0.800	0.003	0.037	0.101	0.181	-0.117	-0.108	0.058	0.172	
0.825	0.015	0.045	0.105	0.183	-0.119	-0.088	0.044	0.137	
0.850	0.023	0.055	0.120	0.196	-0.102	-0.087	0.034	0.116	
0.950	-0.017	0.013	0.083	0.156	-0.066	-0.022	0.025	0.071	
0.462	0.014	-0.137	-0.080	0.124	0.328	-0.219	-0.202	-0.094	0.023
	0.023	-0.130	-0.066	0.152	0.331	-0.210	-0.190	-0.073	0.040
	0.047	-0.179	-0.104	0.134	0.270	-0.192	-0.184	-0.057	0.047
	0.076	-0.128	-0.044	0.200	0.324	-0.189	-0.098	0.036	0.120
	0.099	-0.095	0.105	0.207	0.323	-0.001	0.009	0.049	0.147
	0.206	0.049	0.105	0.186	0.259	-0.007	0.019	0.096	0.180
	0.259	0.032	0.079	0.148	0.229	-0.027	0.000	0.067	0.155
	0.306	-0.009	0.037	0.109	0.191	-0.074	-0.058	-0.032	0.000
	0.402	0.015	0.057	0.127	0.213	-0.103	-0.075	0.071	0.374
	0.501	0.000	0.040	0.111	0.191	-0.098	0.112	0.201	0.232
	0.604	-0.002	0.039	0.104	0.174	0.078	0.098	0.148	0.230
	0.705	-0.003	0.034	0.101	0.170	0.017	0.057	0.136	0.269
	0.755	-0.017	0.024	0.082	0.153	-0.019	0.012	0.086	0.255
	0.797	-0.015	0.016	0.079	0.150	-0.063	-0.033	0.058	0.186
	0.813	0.009	0.043	0.117	0.188	-0.022	0.006	0.108	0.235
	0.856	-0.002	0.028	0.090	0.164	-0.032	-0.002	0.096	0.226
	0.907	-0.006	0.020	0.084	0.151	-0.099	-0.061	0.032	0.142
	0.957	-0.048	-0.022	0.035	0.107	-0.068	-0.063	0.018	0.125
0.340	0.000	0.313	0.329	0.335	0.281	0.374	0.378	0.359	0.275
	0.015	-0.129	-0.045	0.152	0.296	-0.052	0.035	0.211	0.333
	0.028	-0.131	-0.035	0.123	0.251	-	-	-	-
	0.056	-0.128	-0.019	0.105	0.221	-0.007	0.105	0.229	0.274
	0.075	-0.111	-0.017	0.085	0.187	0.009	0.087	0.188	0.320
	0.100	-0.043	-0.009	0.080	0.178	0.099	0.089	0.215	0.473
	0.150	-0.030	0.010	0.090	0.184	0.084	0.163	0.341	0.532
	0.250	-0.003	0.030	0.078	0.174	-0.128	-0.044	0.106	0.254
	0.306	-0.024	0.006	0.072	0.166	-0.152	-0.095	0.033	0.148
	0.400	-0.021	0.021	0.078	0.161	-0.132	-0.082	0.053	0.146
	0.500	-0.036	-0.007	0.054	0.134	0.012	0.015	0.059	0.127
	0.600	-0.036	-0.005	0.054	0.131	0.095	0.121	0.172	0.261
	0.700	-0.041	-0.013	0.047	0.124	0.062	0.090	0.150	0.237
	0.812	-0.047	-0.018	0.041	0.117	0.013	0.059	0.116	0.224
	0.827	0.010	0.034	0.091	0.166	0.064	0.100	0.169	0.290
	0.850	0.005	0.046	0.098	0.162	-0.005	0.084	0.084	0.215
	0.875	-0.052	-0.020	0.039	0.104	-0.013	0.017	0.072	0.198
	0.900	-0.041	-0.027	0.024	0.089	0.012	0.044	0.107	0.227
0.925	-0.020	-0.008	0.045	0.110	0.029	0.060	0.133	0.244	
0.950	-0.013	-0.006	0.040	0.109	-0.023	0.007	0.081	0.171	
0.103	0.000	0.434	0.495	0.418	0.427	0.437	0.468	0.390	0.406
	0.015	0.056	0.113	0.199	0.244	0.016	0.067	0.165	0.208
	0.025	0.043	0.087	0.181	0.223	-0.021	0.064	0.167	0.214
0.104	0.050	0.029	0.066	0.143	0.211	-0.034	0.008	0.084	0.156
	0.100	0.015	0.043	0.104	0.187	-0.005	0.046	0.092	0.181
	0.150	0.026	0.044	0.101	0.166	0.007	0.024	0.083	0.154
0.103	0.200	0.008	0.033	0.088	0.148	0.049	0.071	0.181	0.243
	0.250	0.026	0.051	0.107	0.171	0.083	0.090	0.180	0.204
	0.300	0.018	0.042	0.104	0.174	0.030	0.045	0.114	0.196
0.076	0.500	-0.026	0.001	0.056	0.119	0.065	0.075	0.149	0.276
0.062	0.700	0.016	0.083	0.105	0.168	-0.077	-0.051	0.041	0.143
0.055	0.750	0.034	0.063	0.118	0.176	-0.095	-0.068	0.033	0.099
0.052	0.950	-0.041	-0.021	0.028	0.082	-0.009	0.007	0.081	0.124

TABLE III.- EXPERIMENTAL PRESSURE COEFFICIENTS; M = 1.9 - Continued
(c) Upper surface, right wing panel

y/T	x/c	Without nacelles				With nacelles				
		$\alpha = -2.2^\circ$	$\alpha = -0.1^\circ$	$\alpha = 4.2^\circ$	$\alpha = 8.4^\circ$	$\alpha = -2.2^\circ$	$\alpha = -0.1^\circ$	$\alpha = 4.2^\circ$	$\alpha = 8.4^\circ$	
0.256	0.000	-0.258	-0.244	-0.106	0.305	-0.215	-0.214	-0.161	-0.103	
	0.050	0.231	0.197	0.125	0.011	0.163	0.159	0.127	0.090	
	0.100	---	---	---	---	0.125	0.091	0.048	0.001	
	0.200	0.076	0.030	-0.046	-0.127	0.021	-0.021	-0.070	-0.109	
	0.400	0.005	-0.038	-0.107	-0.181	-0.003	-0.063	-0.118	-0.141	
	0.700	-0.048	-0.092	-0.144	-0.200	-0.048	-0.084	-0.133	-0.186	
	0.900	-0.103	-0.157	-0.215	-0.250	-0.048	-0.097	-0.145	-0.183	
0.445	0.000	0.238	0.280	0.331	0.273	0.544	0.540	0.516	0.470	
	0.756	-0.004	-0.064	-0.178	-0.249	-0.027	-0.077	-0.166	-0.226	
	0.777	0.004	-0.047	-0.153	-0.224	-0.025	-0.054	-0.139	-0.204	
	0.950	-0.008	-0.035	-0.102	-0.198	-0.035	-0.055	-0.112	-0.198	
0.580	0.000	0.162	0.259	0.383	0.485	0.107	0.167	0.285	0.388	
	0.015	0.281	0.255	0.178	0.056	0.283	0.261	0.214	0.156	
	0.050	0.145	0.102	0.011	-0.087	0.136	0.056	0.029	-0.034	
	0.075	0.116	0.060	-0.024	-0.112	0.106	-0.056	-0.008	-0.077	
	0.105	0.037	-0.019	-0.104	-0.179	0.028	-0.014	-0.008	-0.153	
	0.200	-0.023	-0.083	-0.164	-0.225	-0.020	-0.072	-0.149	-0.203	
	0.300	-0.046	-0.091	-0.184	-0.246	-0.004	-0.054	-0.167	-0.230	
	0.410	-0.022	-0.071	-0.174	-0.233	-0.011	-0.053	-0.150	-0.215	
	0.500	---	---	---	---	0.019	-0.024	-0.121	-0.182	
	0.600	-0.018	-0.057	-0.159	-0.248	0.036	-0.001	-0.103	-0.175	
	0.700	-0.002	-0.039	-0.106	-0.206	0.026	-0.009	-0.094	-0.184	
	0.756	-0.010	-0.055	-0.113	-0.198	-0.003	-0.035	-0.098	-0.193	
	0.779	0.014	-0.027	-0.095	-0.207	0.034	0.005	-0.086	-0.152	
	0.800	---	---	---	---	0.001	-0.016	-0.067	-0.162	
	0.825	0.001	-0.025	-0.078	-0.167	0.010	0.000	-0.043	-0.118	
	0.850	-0.021	-0.045	-0.098	-0.185	-0.029	-0.050	-0.100	-0.187	
	0.900	0.007	-0.027	-0.065	-0.170	-0.035	-0.053	-0.102	-0.182	
0.950	0.007	-0.030	-0.078	-0.160	-0.039	-0.062	-0.106	-0.183		
0.457	0.000	0.327	0.329	0.316	0.223	0.311	0.298	0.329	0.354	
	0.015	0.299	0.258	0.173	0.046	0.234	0.199	0.135	0.072	
	0.025	0.212	0.159	0.058	-0.044	0.194	0.149	0.071	0.000	
	0.050	0.162	0.105	0.014	-0.076	0.112	0.077	0.000	-0.064	
	0.100	0.057	0.004	-0.078	-0.166	0.000	-0.050	-0.130	-0.191	
	0.150	-0.013	-0.077	-0.152	-0.212	-0.035	-0.081	-0.150	-0.206	
	0.205	-0.039	-0.090	-0.188	-0.258	-0.016	-0.059	-0.164	-0.221	
	0.315	0.113	-0.047	-0.101	-0.162	0.000	-0.021	-0.092	-0.163	
	0.340	0.000	0.210	0.253	0.332	0.377	0.249	0.285	0.341	0.351
		0.015	0.222	0.185	0.084	-0.030	0.225	0.180	0.070	-0.049
0.025		0.158	0.097	0.000	-0.094	0.157	0.103	-0.003	-0.109	
0.050		0.107	0.056	-0.041	-0.125	0.057	0.006	-0.087	-0.169	
0.075		0.049	-0.014	-0.128	-0.187	0.042	-0.017	-0.119	-0.193	
0.100		0.040	-0.022	-0.126	-0.196	0.040	-0.015	-0.127	-0.193	
0.153		0.008	-0.037	-0.140	-0.220	0.026	-0.023	-0.136	-0.222	
0.250		-0.021	-0.051	-0.135	-0.217	0.001	-0.041	-0.115	-0.186	
0.300		---	---	---	---	-0.001	-0.021	-0.077	-0.147	
0.400		0.014	-0.021	-0.073	-0.214	-0.015	-0.039	-0.097	-0.147	
0.500		0.018	-0.007	-0.055	-0.105	0.018	0.000	-0.045	-0.079	
0.600		0.007	-0.018	-0.022	-0.105	0.023	0.003	-0.036	-0.074	
0.697		0.009	-0.014	-0.057	-0.092	0.040	0.021	-0.019	0.052	
0.810		-0.006	-0.033	-0.074	-0.114	0.046	0.029	-0.011	0.049	
0.827		-0.003	-0.029	-0.070	-0.109	0.017	-0.006	-0.055	-0.096	
0.850		-0.009	-0.032	-0.067	-0.111	0.023	0.000	-0.049	-0.090	
0.875		0.013	-0.011	-0.057	-0.097	0.013	-0.013	-0.066	-0.107	
0.900	0.026	-0.001	-0.045	-0.083	0.046	0.027	-0.014	-0.058		
0.925	-0.008	-0.026	-0.069	-0.107	0.033	-0.004	-0.056	-0.100		
0.950	-0.031	-0.055	-0.097	-0.130	0.018	-0.008	-0.060	-0.104		
0.234	0.000	0.233	0.279	0.384	0.400	0.416	0.415	0.457	0.419	
	0.015	0.254	0.215	0.130	0.035	0.352	0.268	0.137	0.018	
	0.025	0.152	0.108	0.000	-0.092	0.216	0.177	-0.005	-0.114	
	0.053	0.095	0.032	-0.022	-0.155	0.076	0.011	-0.113	-0.159	
	0.150	0.013	-0.028	-0.110	-0.201	0.028	-0.016	-0.112	-0.206	
	0.300	0.027	0.000	-0.054	-0.144	0.020	-0.006	-0.080	-0.175	
	0.400	0.038	0.008	-0.052	-0.106	0.043	0.000	-0.047	-0.111	
	0.500	0.045	0.019	-0.026	-0.061	-0.012	-0.014	-0.080	-0.118	
	0.600	0.060	0.026	-0.016	-0.051	-0.004	-0.033	-0.079	-0.118	
	0.700	0.062	0.029	-0.010	-0.032	-0.003	-0.032	-0.074	-0.115	
0.750	0.038	0.006	-0.037	-0.071	0.005	-0.031	-0.081	-0.121		
0.800	0.025	-0.002	-0.046	-0.084	0.007	-0.007	-0.045	-0.085		
0.825	0.000	-0.026	-0.071	-0.107	0.004	-0.009	-0.046	-0.082		
0.103	0.000	0.414	0.449	0.463	0.400	0.429	0.469	0.448	0.388	
	0.015	0.260	0.210	0.098	-0.007	---	---	---	---	
	0.025	0.161	0.133	0.053	-0.028	0.190	0.148	0.061	-0.023	
	0.050	0.103	0.074	0.024	-0.041	0.053	0.026	-0.020	-0.083	
	0.100	0.068	0.026	-0.030	-0.098	0.062	0.021	-0.040	-0.101	
	0.150	0.039	0.024	-0.042	-0.098	0.013	-0.014	-0.082	-0.141	
	0.253	0.011	-0.018	-0.056	-0.097	0.039	0.011	-0.022	-0.045	
	0.307	0.006	-0.011	-0.039	-0.082	0.078	0.057	0.012	-0.010	
	0.386	0.398	0.337	0.000	-0.055	0.103	0.078	0.026	-0.019	
	0.488	0.496	0.450	-0.008	-0.054	0.101	0.077	0.027	-0.016	
0.088	0.000	0.000	0.000	-0.038	-0.063	0.422	0.277	0.001	0.020	
	0.075	0.700	-0.014	-0.055	-0.096	-0.009	-0.026	-0.067	-0.104	
	0.090	0.750	-0.009	-0.030	-0.066	-0.103	-0.023	-0.074	-0.107	
	0.106	0.804	-0.085	-0.056	-0.095	0.017	0.007	-0.026	-0.059	
	0.128	0.849	-0.002	-0.038	-0.079	0.064	0.051	0.017	-0.007	
	0.137	0.875	0.004	-0.004	-0.008	0.070	0.068	0.063	0.081	

TABLE III.- EXPERIMENTAL PRESSURE COEFFICIENTS; M = 1.9 - Concluded
(d) Lower surface, right wing panel

$\frac{2y}{b}$	x/c	Without nacelles				With nacelles			
		$\alpha = -2.2^\circ$	$\alpha = -0.1^\circ$	$\alpha = 4.2^\circ$	$\alpha = 8.4^\circ$	$\alpha = -2.2^\circ$	$\alpha = -0.1^\circ$	$\alpha = 4.2^\circ$	$\alpha = 8.4^\circ$
0.897	0.000	-0.272	-0.268	-0.142	0.262	-0.219	-0.234	-0.132	0.054
	0.050	-0.262	-0.264	-0.172	0.132	-0.224	-0.236	-0.195	-0.068
	0.100	-0.261	-0.264	-0.147	0.138	-0.213	-0.230	-0.180	-0.029
	0.400	-0.053	-0.246	-0.072	0.104	-0.142	-0.204	-0.157	-0.011
	0.600	0.000	-0.044	-0.006	0.069	0.113	0.084	0.109	0.152
0.645	0.025	-0.214	-0.179	0.024	0.270	-0.187	-0.185	-0.068	0.185
	0.050	-0.250	-0.216	0.014	0.207	-0.204	-0.175	-0.031	0.180
	0.150	-0.209	-0.105	0.087	0.181	-0.139	-0.071	0.152	0.189
	0.300	-0.001	0.016	0.065	0.134	-0.040	-0.009	0.067	0.231
	0.770	-0.077	-0.052	0.027	0.112	-0.173	-0.156	-0.024	0.068
	0.800	-0.082	-0.051	0.017	0.097	-0.111	-0.107	-0.017	0.045
	0.875	-0.077	-0.048	0.017	0.097	-0.117	-0.079	-0.001	0.057
	0.940	-0.084	-0.066	-0.007	0.074	-0.124	-0.064	0.000	0.032
	0.444	0.021	-0.138	-0.129	0.041	0.207	-0.097	-0.074	0.002
0.036	-0.182	-0.133	0.071	0.208	-0.133	-0.109	-0.033	0.049	
0.060	-0.212	-0.096	0.062	0.180	-0.145	-0.119	-0.056	0.005	
0.079	-0.155	-0.087	0.080	0.190	-0.138	-0.112	-0.053	0.009	
0.099	-0.070	0.016	0.112	0.213	-0.071	-0.062	-0.024	0.044	
0.149	-0.068	-0.014	0.074	0.176	-0.117	-0.092	-0.016	0.056	
0.194	-0.066	-0.018	0.059	0.145	-0.045	-0.029	0.051	0.126	
0.293	-0.070	-0.042	0.007	0.118	-0.103	-0.075	-0.016	0.054	
0.601	-0.066	-0.044	0.025	0.105	-0.046	0.078	0.103	0.180	
0.701	-0.071	-0.045	0.015	0.092	0.028	0.064	0.126	0.208	
0.751	-0.073	-0.047	0.015	0.094	0.016	0.055	0.114	0.226	
0.792	-0.049	-0.029	0.033	0.105	0.023	0.055	0.114	0.260	
0.814	-0.032	-0.021	0.042	0.106	0.031	0.042	0.107	0.260	
0.850	-0.051	-0.027	0.026	0.092	-0.033	-0.016	0.062	0.210	
0.900	-0.055	-0.033	0.030	0.100	-0.093	-0.078	0.015	0.137	
0.950	-0.065	-0.046	0.015	0.088	-0.081	-0.072	0.021	0.135	
0.234	0.025	-0.055	0.031	0.155	0.268	-0.001	0.092	0.183	0.278
	0.050	-0.022	0.042	0.144	0.251	0.011	0.076	0.166	0.250
	0.075	0.000	0.043	0.139	0.250	0.005	0.040	0.145	0.247
	0.100	-	-	-	-	0.003	0.035	0.148	0.242
	0.150	-0.016	0.012	0.085	0.164	-0.062	-0.016	0.061	0.150
	0.200	-0.032	-0.010	0.043	0.146	0.020	-0.005	0.052	0.158
	0.300	-0.087	-0.054	0.001	0.093	-	-	-	-
	0.400	-0.047	-0.022	0.026	0.111	-	-	-	-
	0.500	-0.042	-0.023	0.026	0.099	-0.074	-0.040	0.044	0.162
	0.600	-0.073	-0.051	0.006	0.083	-0.106	-0.084	-0.050	0.002
	0.700	-0.059	-0.041	0.007	0.080	-0.017	0.000	0.055	0.142
	0.750	-	-	-	-	-0.024	0.002	0.080	0.158
	0.800	-0.053	-0.032	0.023	0.097	-0.002	0.020	0.081	0.153
	0.822	-0.039	-0.017	0.041	0.110	-0.011	0.002	0.058	0.137
	0.839	-0.023	-0.005	0.066	0.209	-0.025	0.000	0.066	0.172
	0.850	-0.070	-0.034	0.016	0.085	0.008	0.027	0.087	0.163
	0.875	-0.044	-0.036	0.004	0.082	-0.016	-0.005	0.044	0.120
0.900	-0.033	-0.017	0.029	0.098	-0.016	0.007	0.057	0.153	
0.925	-0.043	-0.021	0.032	0.101	-0.050	-0.028	0.024	0.133	
0.970	-0.030	-0.012	0.035	0.101	-	-	-	-	
0.156	0.900	-0.049	-0.037	0.007	0.074	-0.042	-0.033	0.026	0.093
	0.925	-0.075	-0.058	-0.019	0.040	-0.050	-0.019	0.035	0.086
	0.950	-0.042	-0.024	0.015	0.076	-0.065	-0.044	-0.002	0.041
	0.970	-0.038	-0.014	0.007	0.054	-0.042	-0.022	0.009	0.055

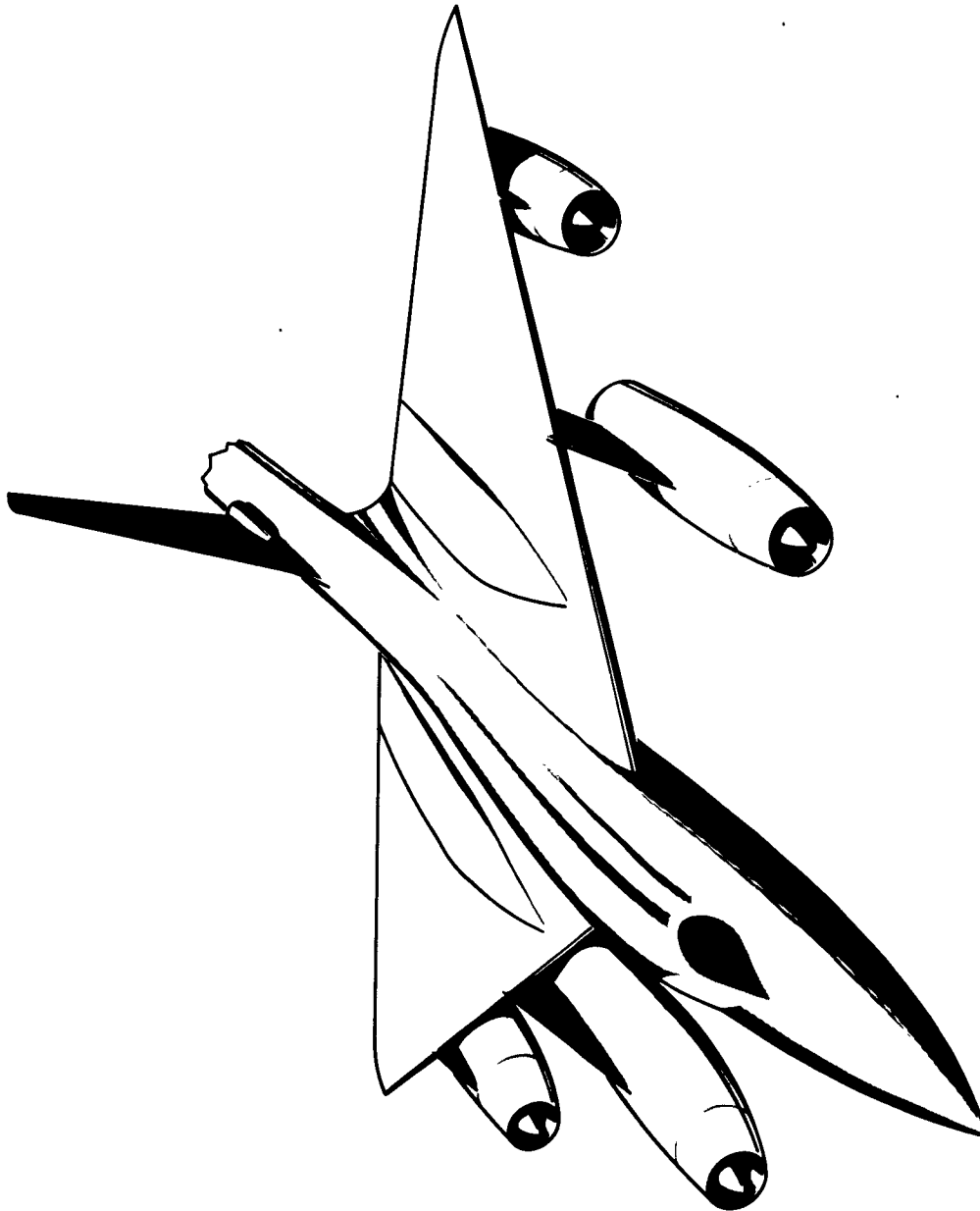
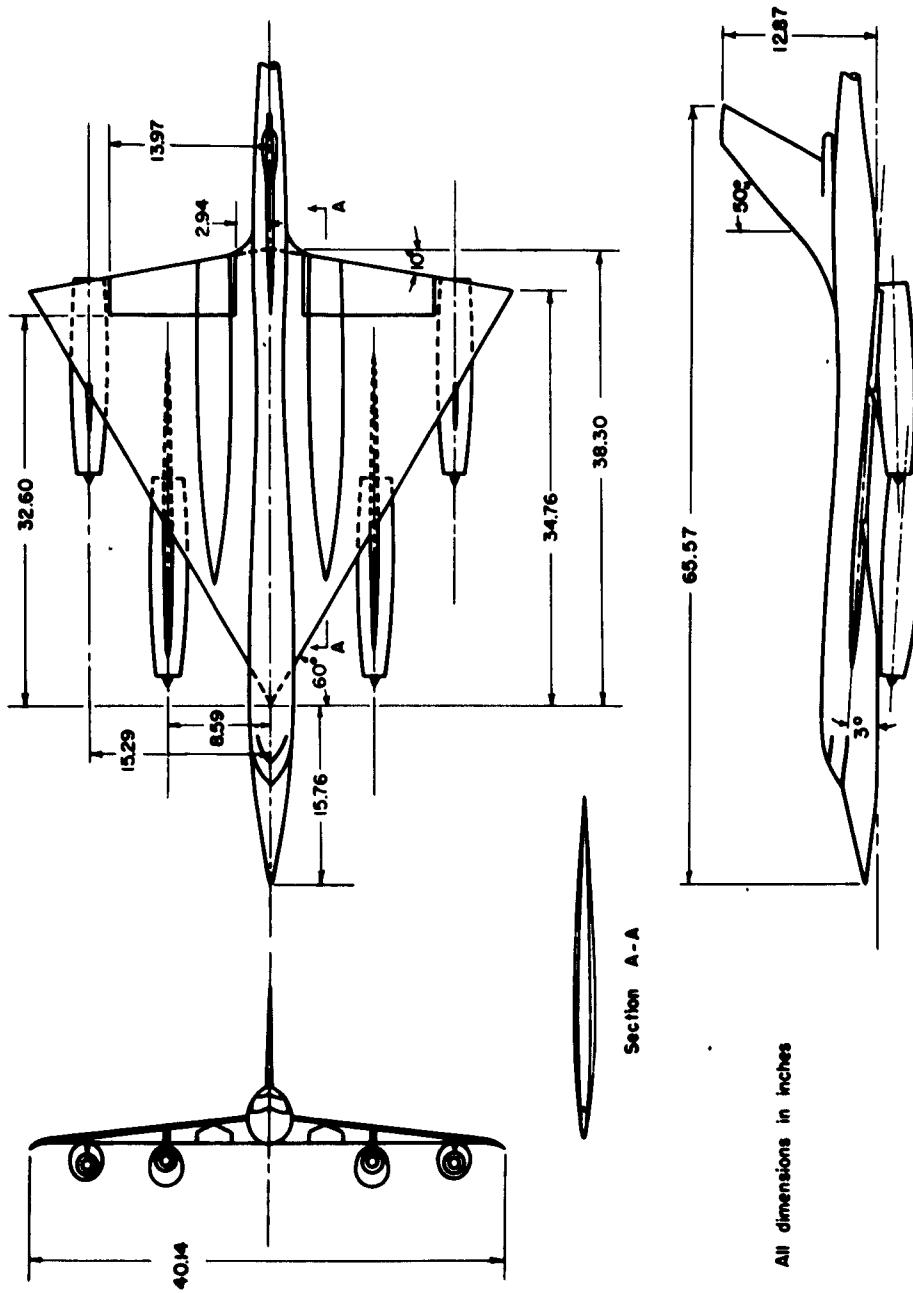
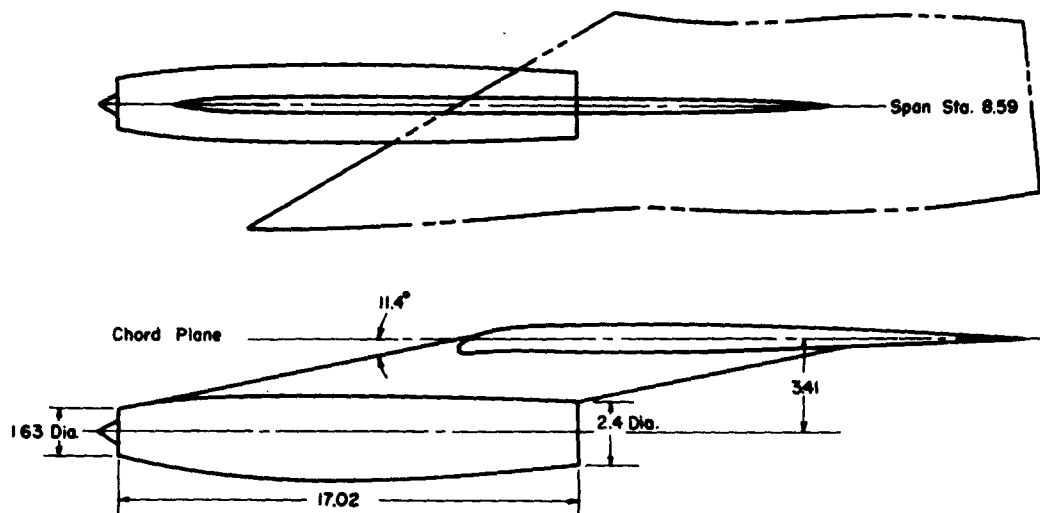

Figure 1.- Perspective of the model.



(a) Three-view sketch.

Figure 2.- Dimensional sketch of model.



(b) Inboard nacelle.

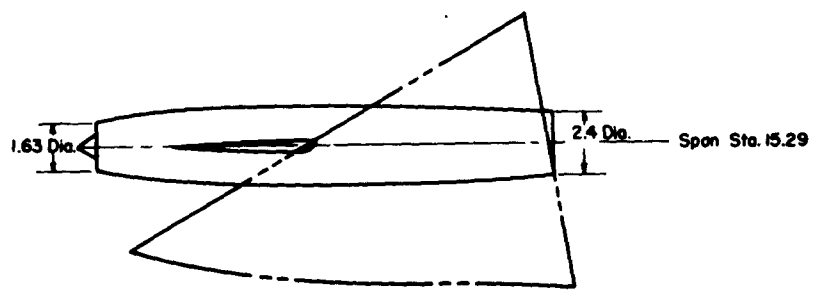

All dimensions in inches

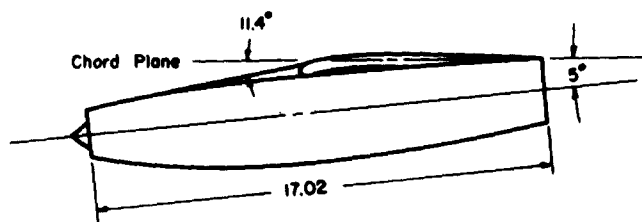

(c) Outboard nacelle.

Figure 2.- Concluded.

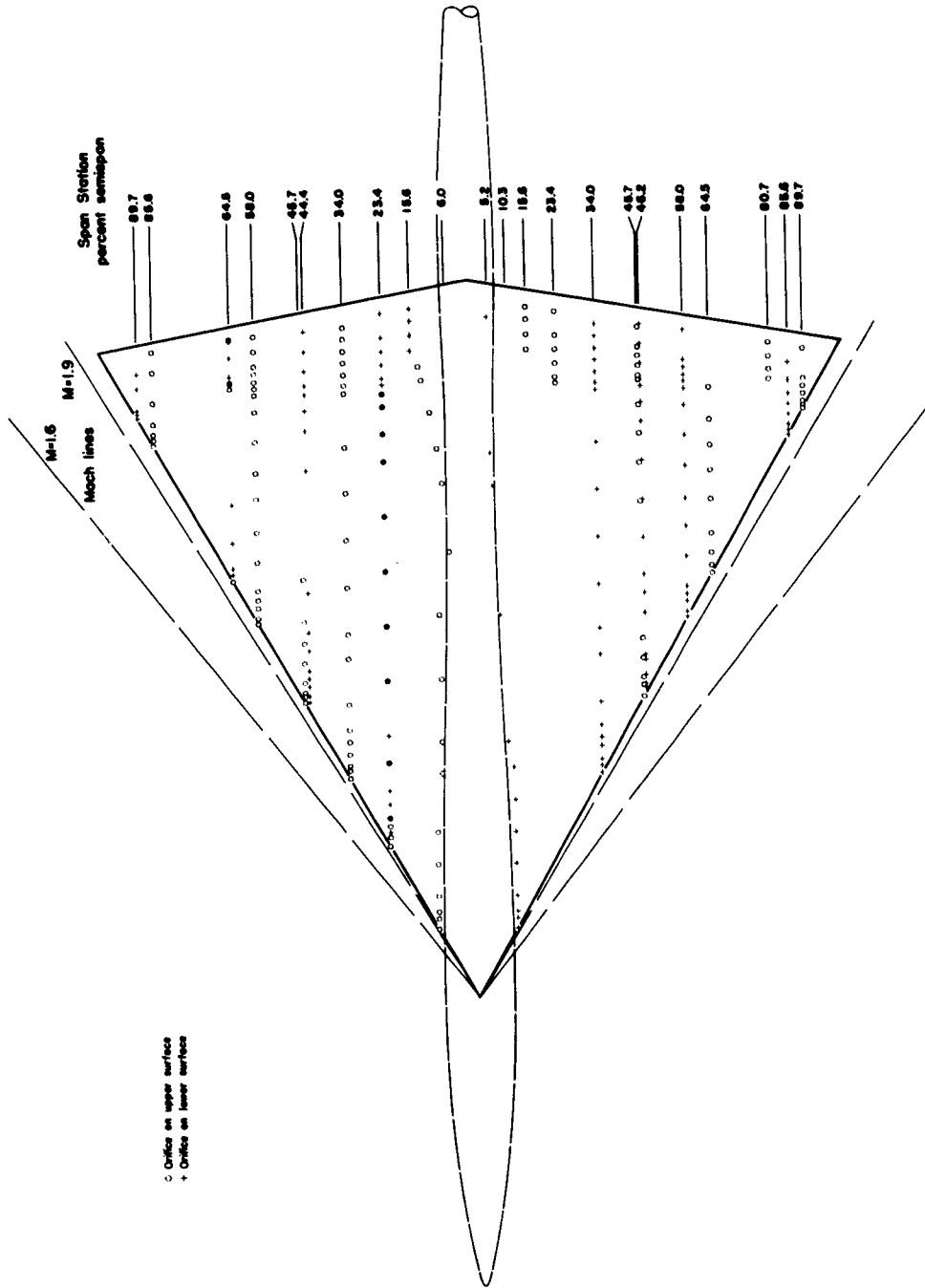
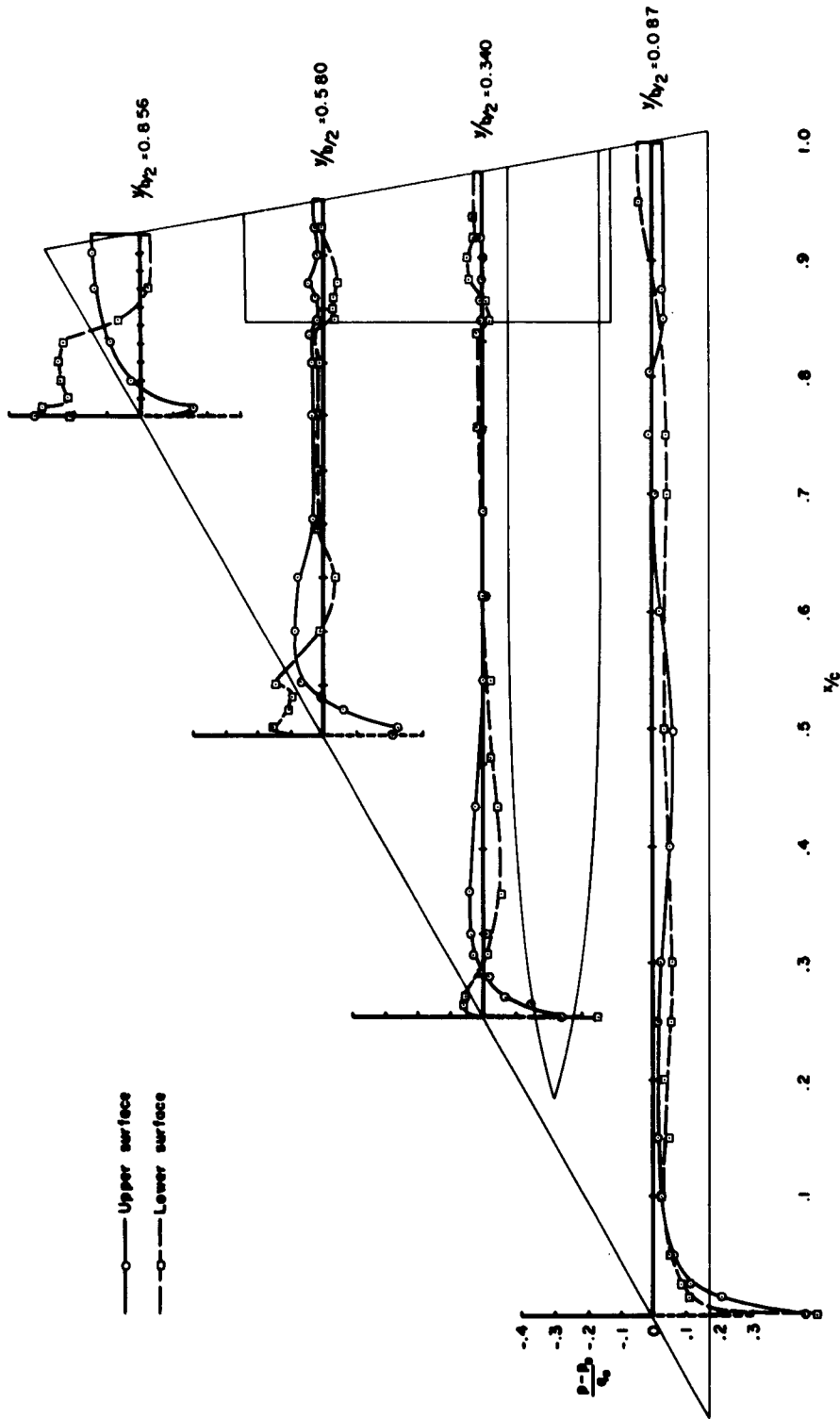
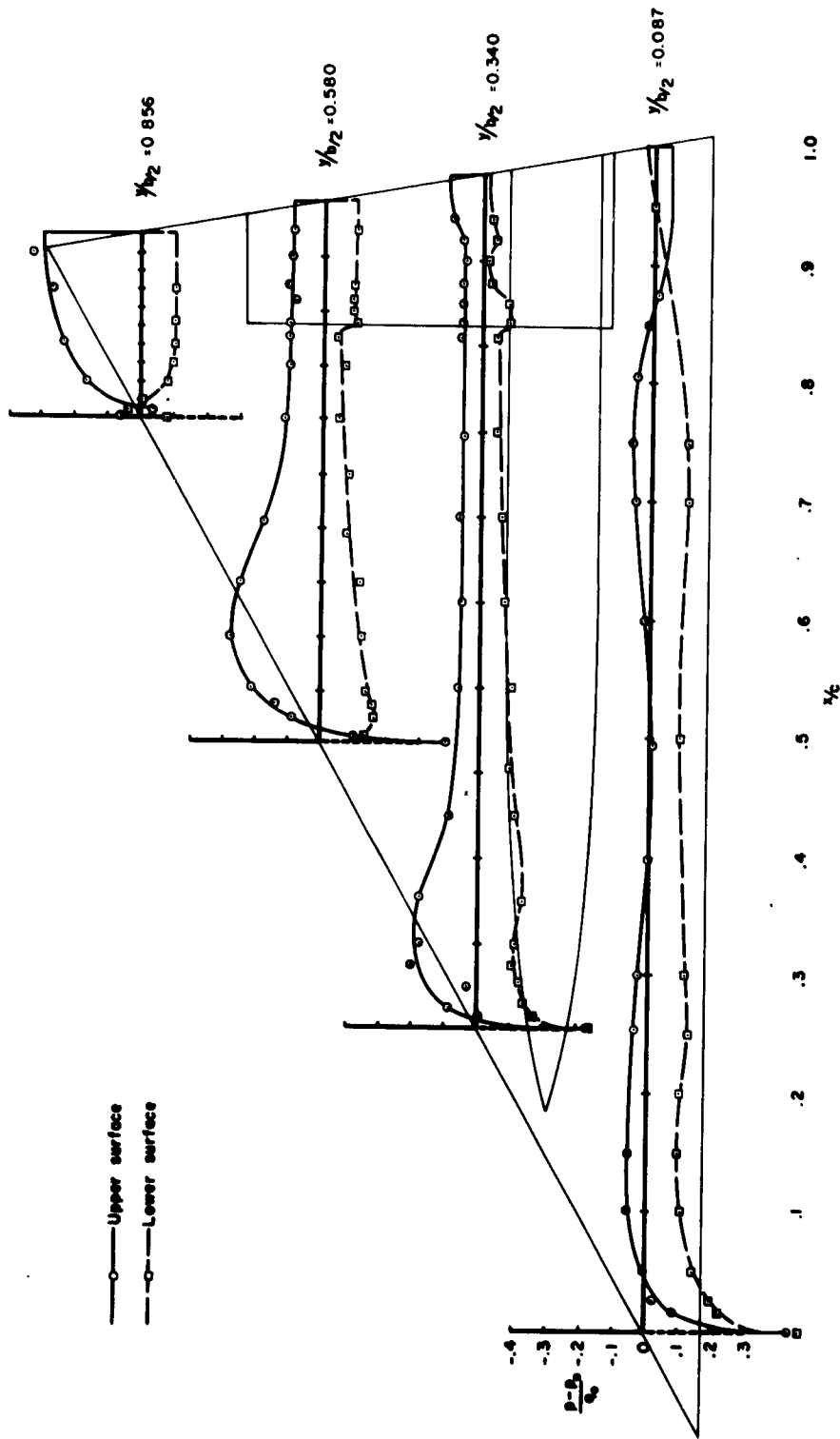

Figure 3.- Graphical representation of wing orifice and Mach line locations.



(a) $\alpha = -0.1^\circ$

Figure 4.- Static-pressure distribution on the conically cambered wing; $M = 1.6$.



(b) $\alpha = 4.2^\circ$

Figure 4.- Continued.

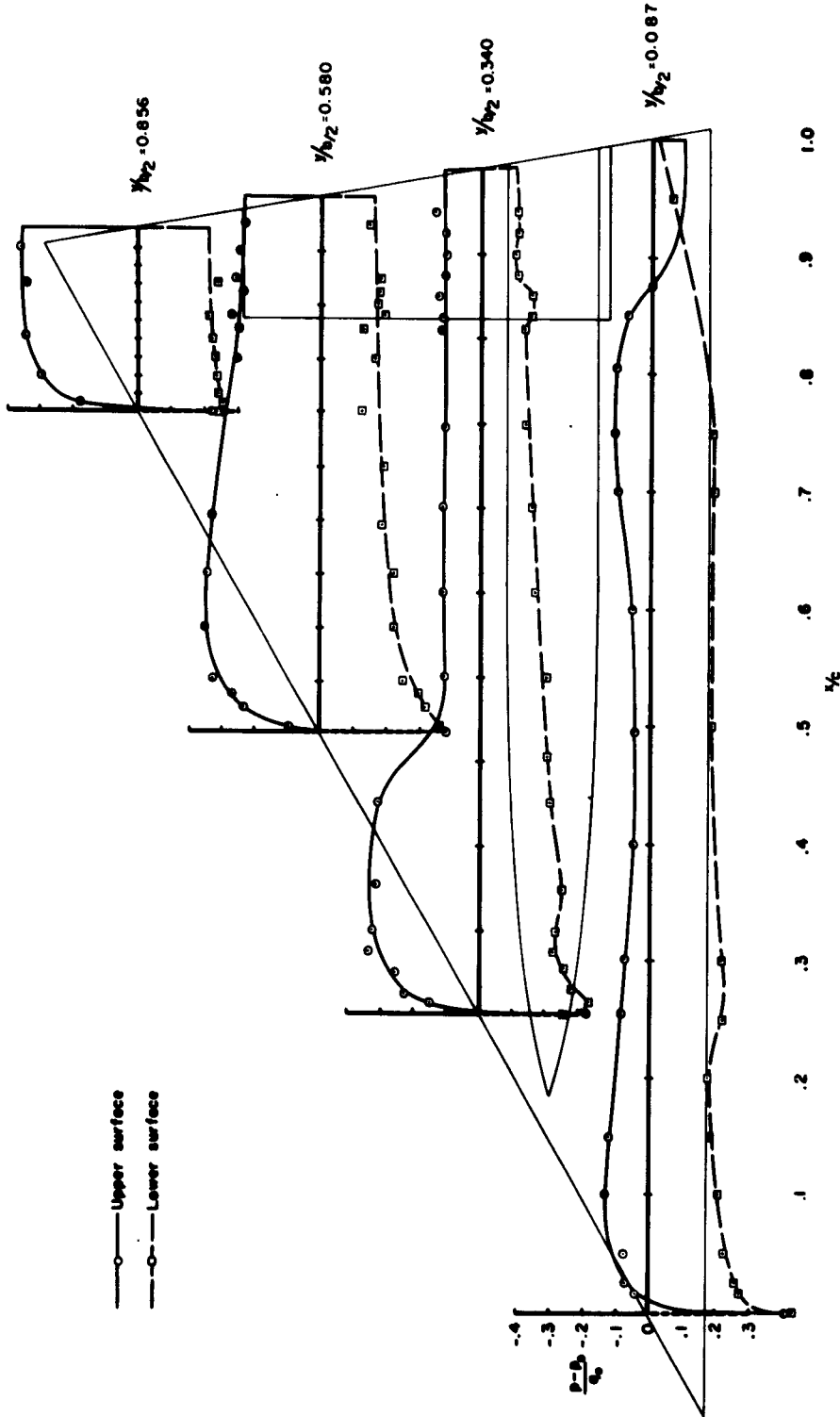

(c) $\alpha = 8.50$

Figure 4.- Concluded.

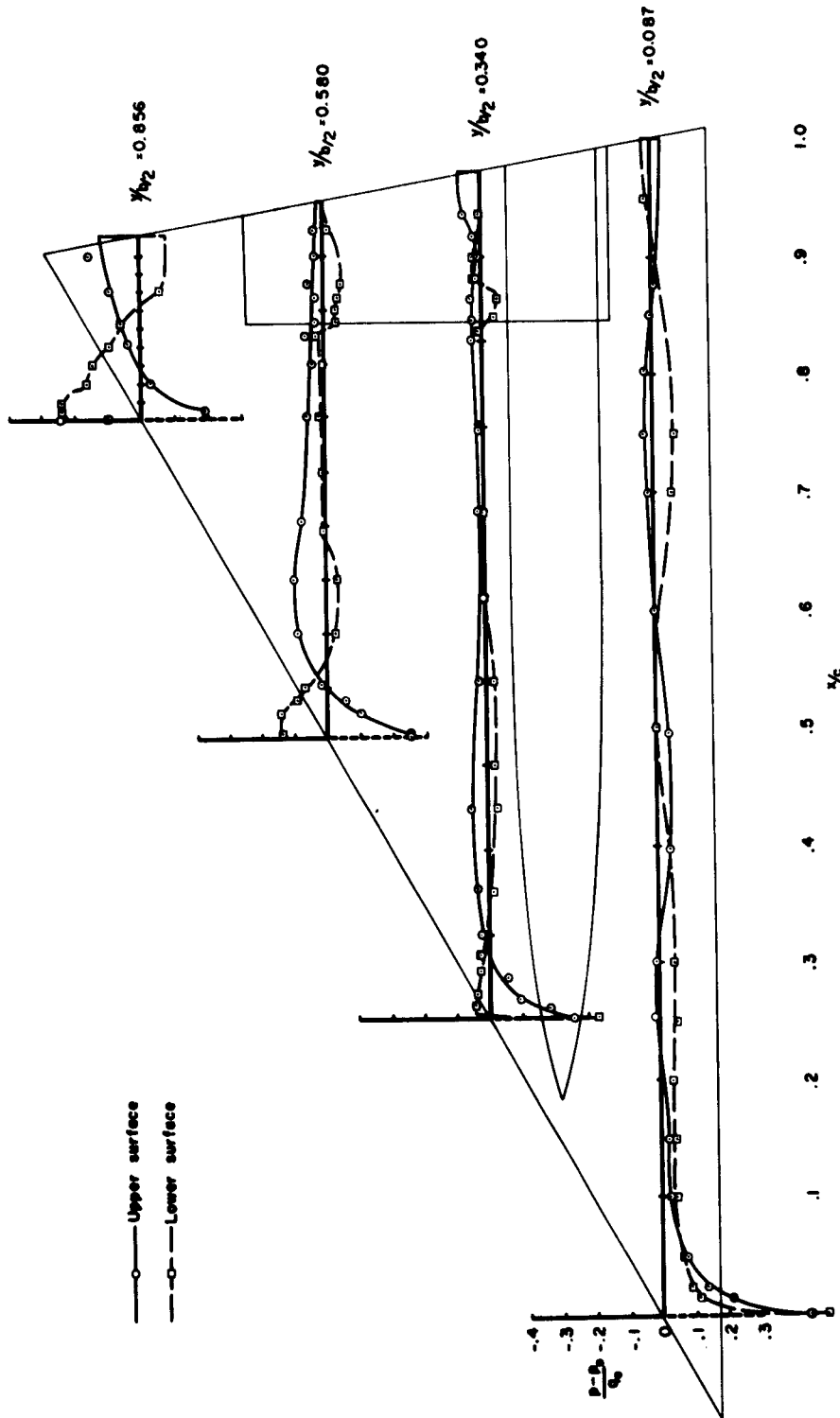

(a) $\alpha = -0.1^\circ$

Figure 5.- Static-pressure distribution on the conically cambered wing; $M = 1.9$.

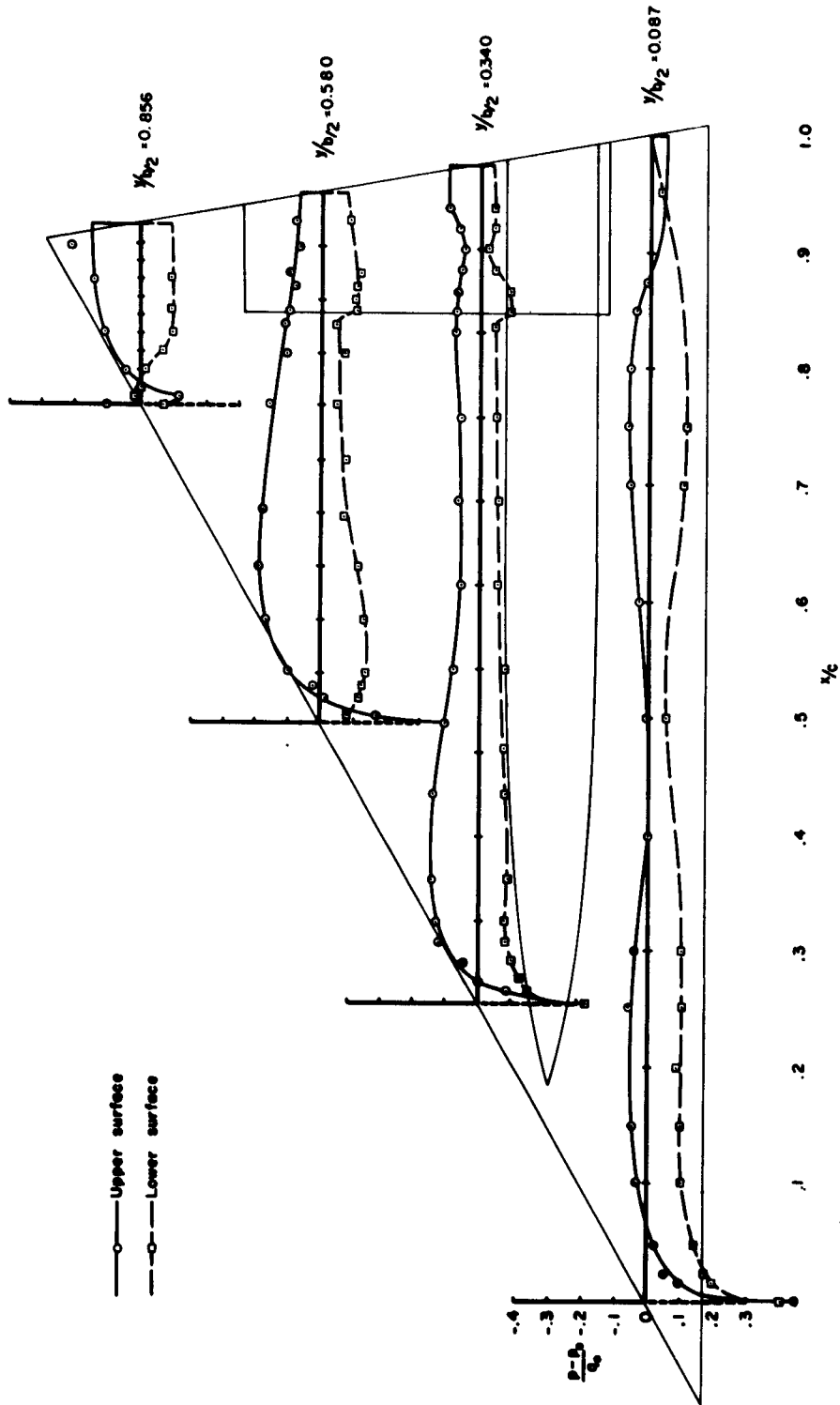

(b) $\alpha = 4.2^\circ$

Figure 5.- Continued.

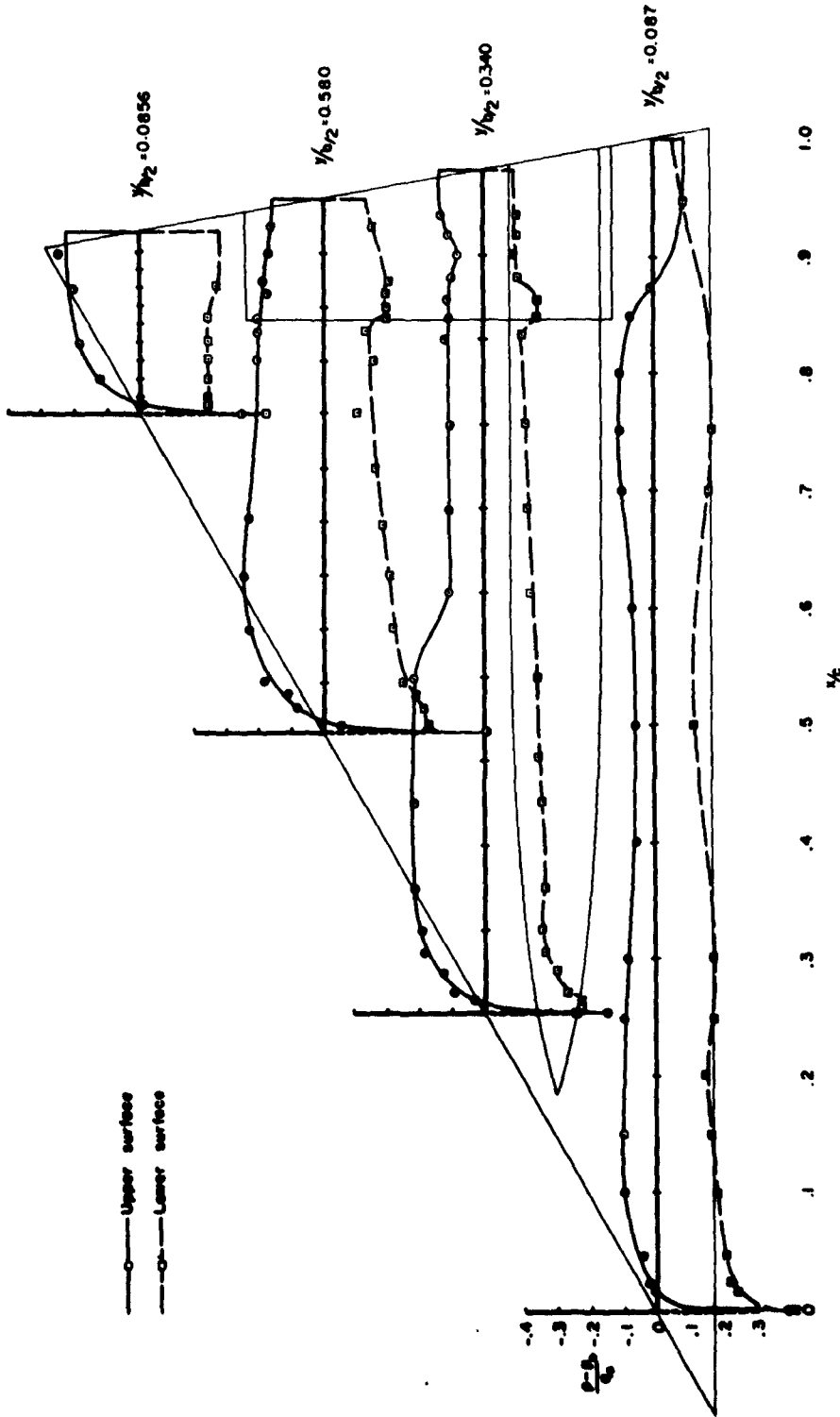

(c) $\alpha = 8.4^\circ$

Figure 5.- Concluded.

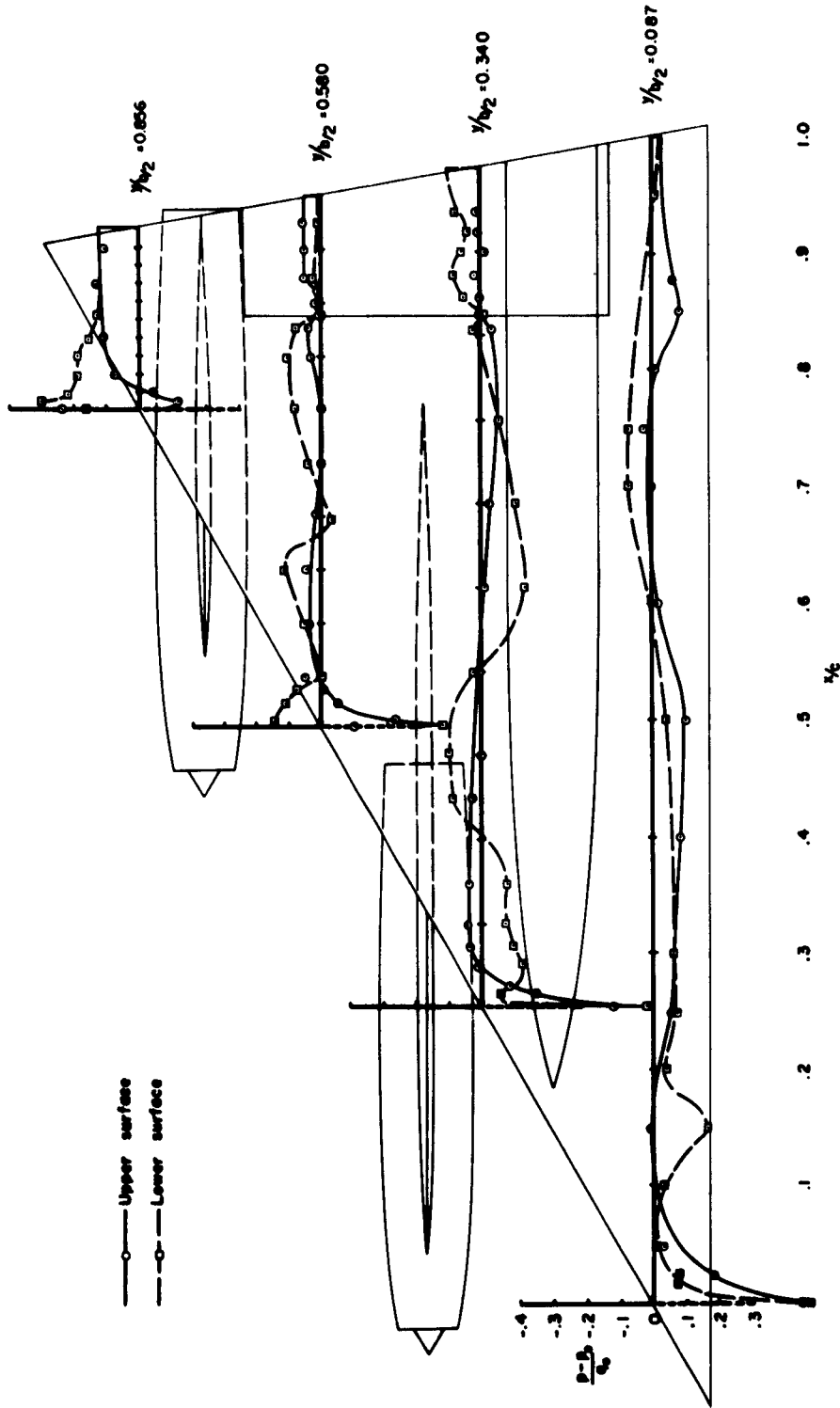

(a) $\alpha = -0.1^\circ$

Figure 6.- Static-pressure distribution on the conically cambered wing with nacelles; $M = 1.6$.

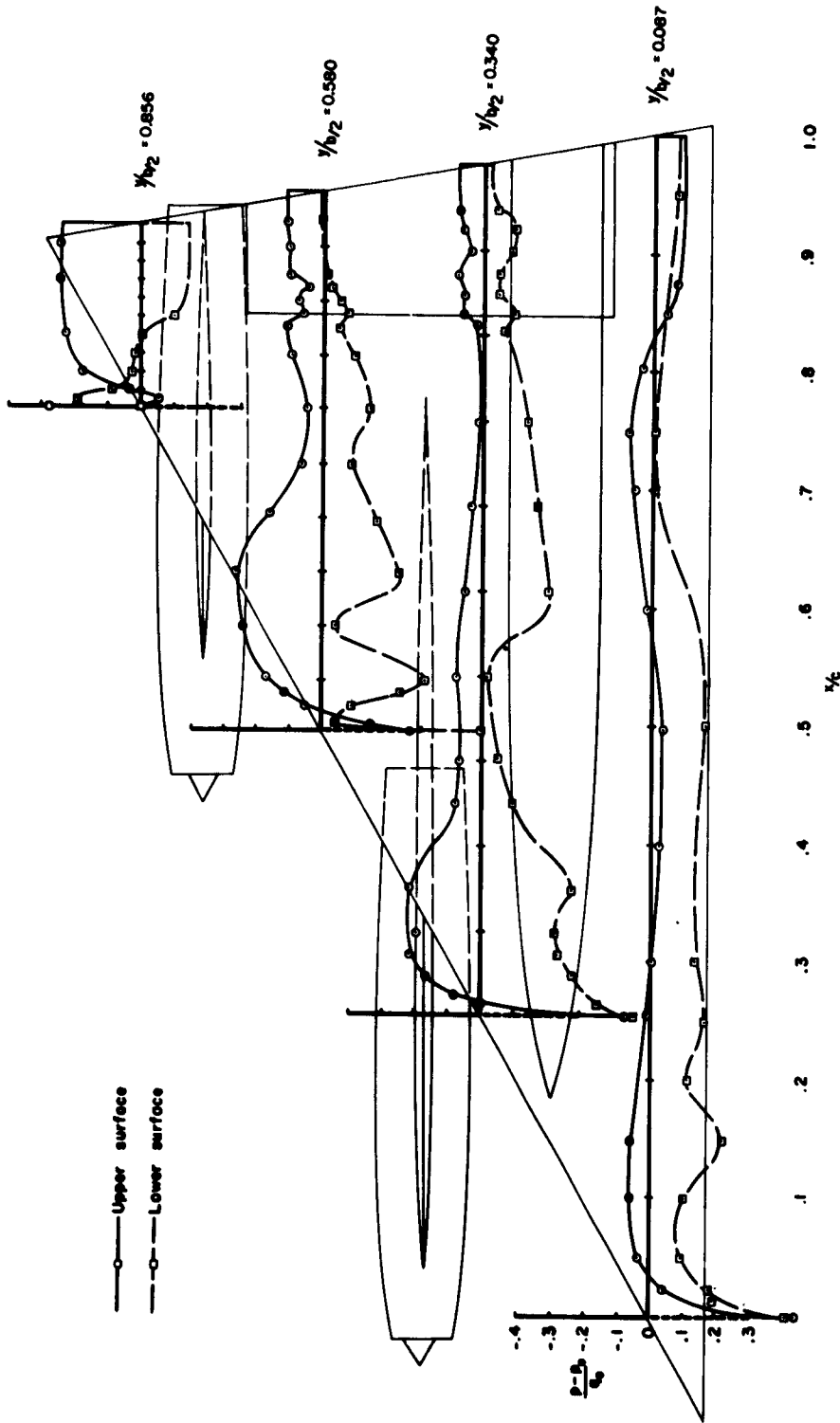

(b) $\alpha = 4.20^\circ$

Figure 6.- Continued.

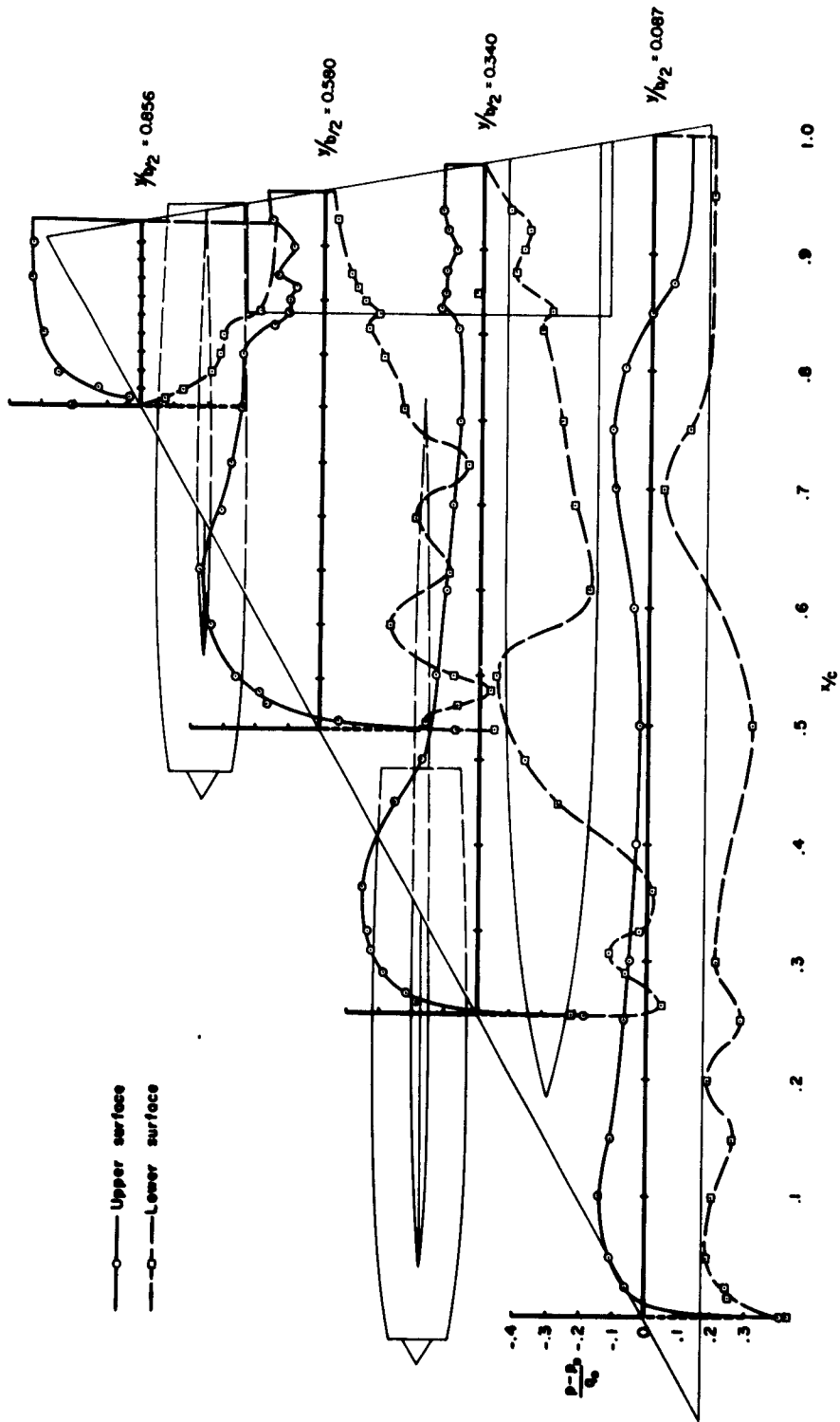

(c) $\alpha = 8.5^\circ$

Figure 6.- Concluded.

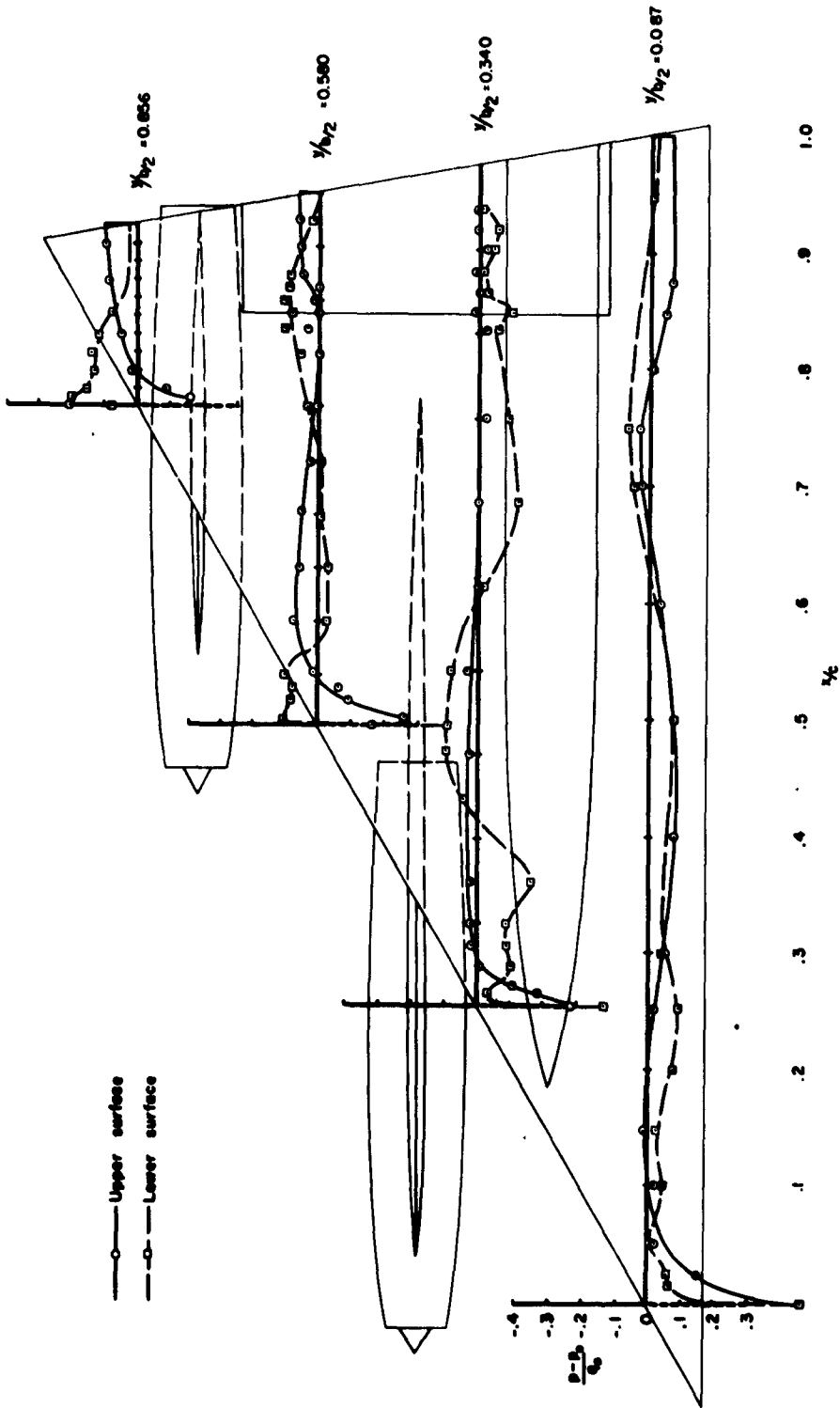

(a) $\alpha = -0.1^\circ$

Figure 7.- Static-pressure distribution on the conically cambered wing with nacelles; $M = 1.9$.

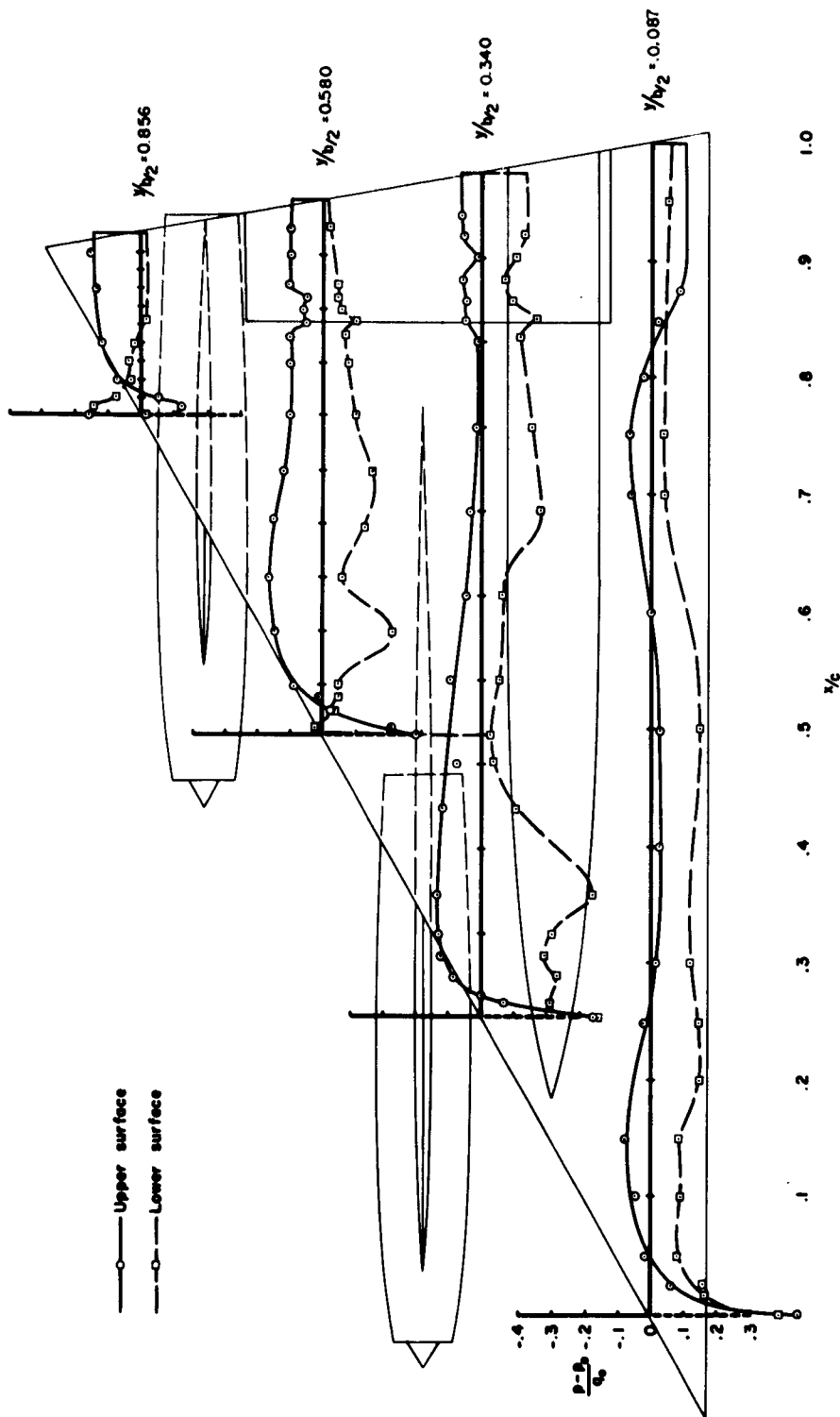

(b) $\alpha = 4.20^\circ$

Figure 7.- Continued.

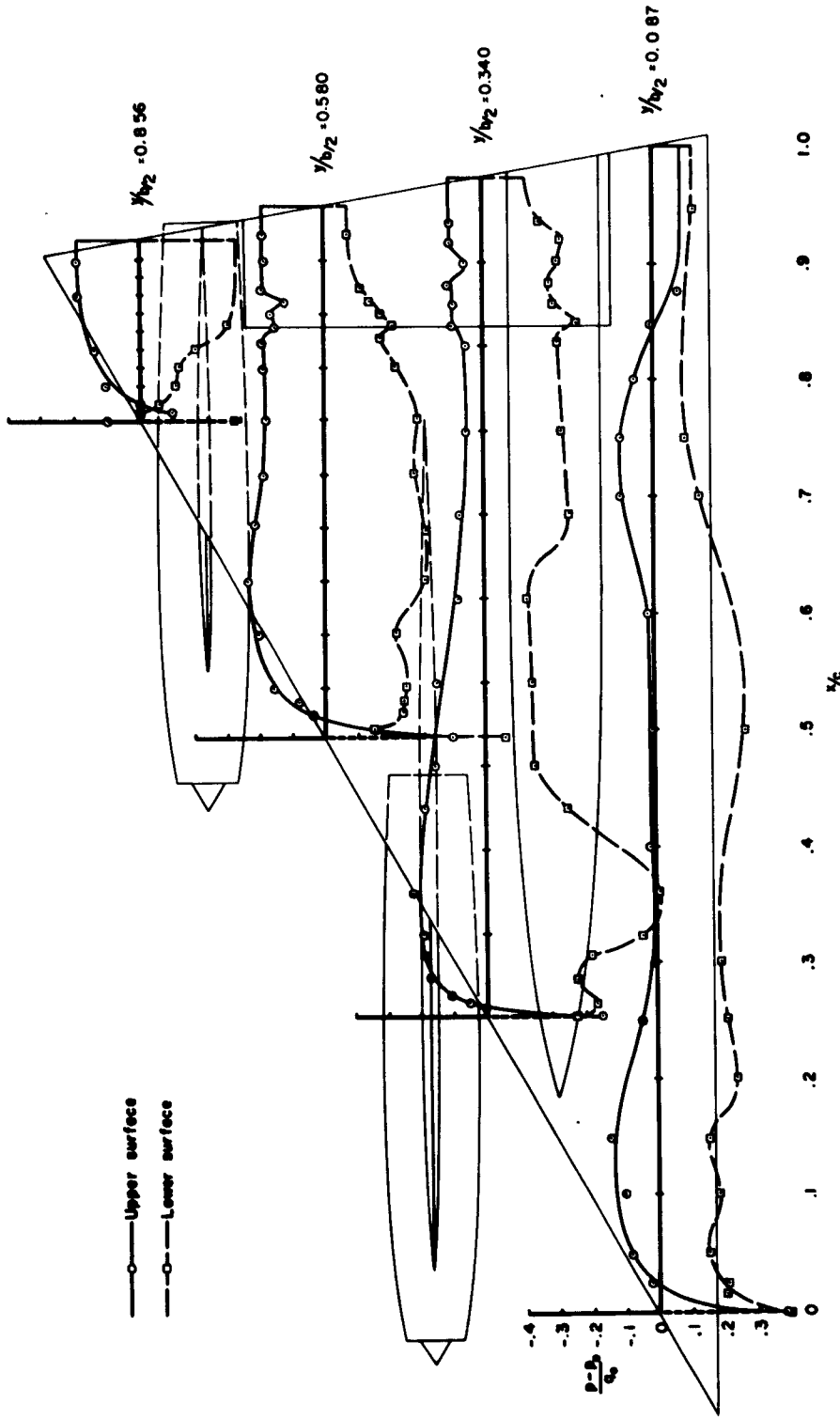

(c) $\alpha = 8.4^\circ$

Figure 7.- Concluded.

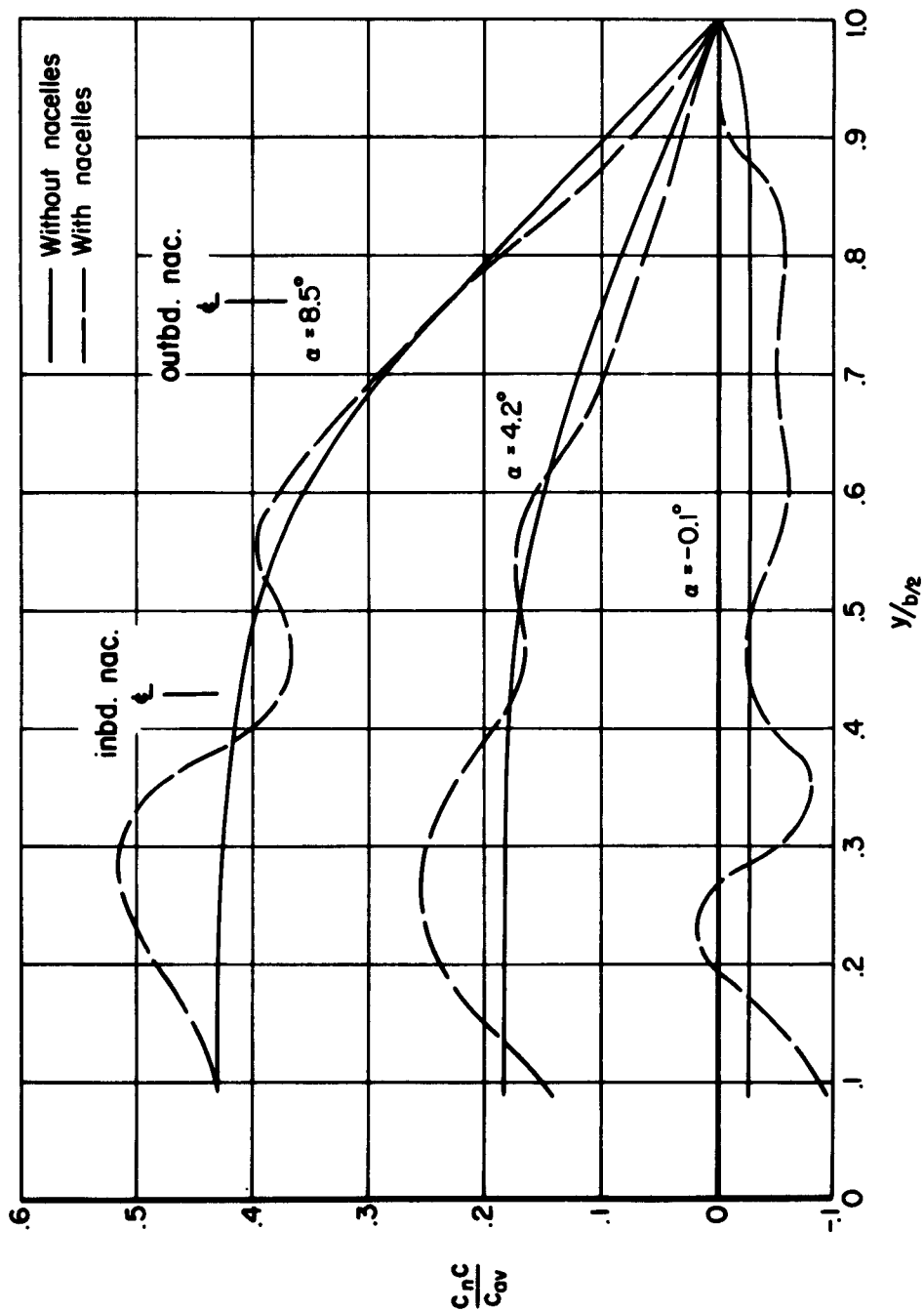

(a) $M = 1.6$

Figure 8.- Comparison of the spanwise load distributions for the wing with and without nacelles.

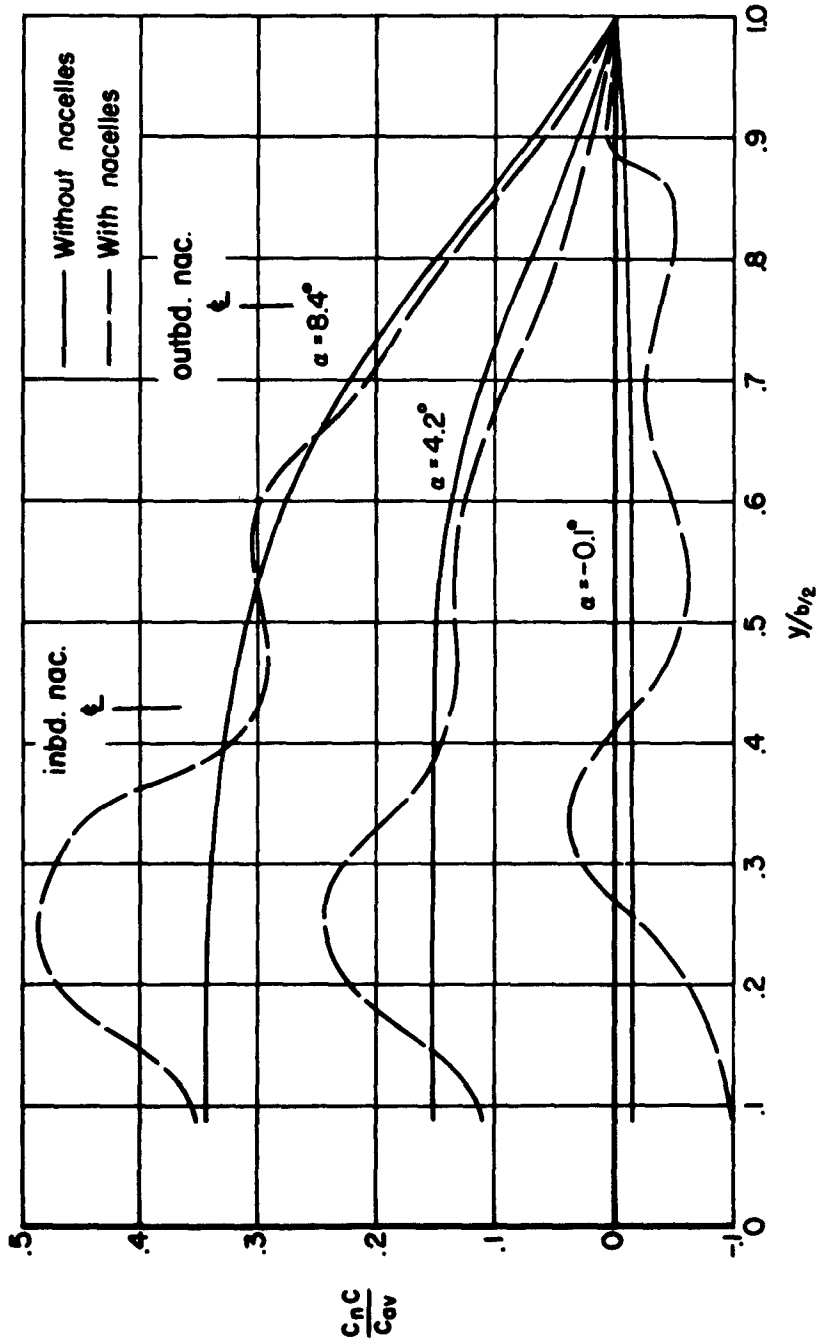

(b) $M = 1.9$

Figure 8.- Concluded.