

UNCLASSIFIED

AD NUMBER
AD093195
NEW LIMITATION CHANGE
TO Approved for public release, distribution unlimited
FROM Distribution authorized to U.S. Gov't. agencies and their contractors; Foreign Government Information; 08 OCT 1936. Other requests shall be referred to British Embassy, 3100 Massachusetts Avenue, NW, Washington, DC 20008.
AUTHORITY
DSTL, DSIR 23/5879, 12 Jun 2008

THIS PAGE IS UNCLASSIFIED

UNCLASSIFIED

AD 93195

Armed Services Technical Information Agency

Reproduced by

DOCUMENT SERVICE CENTER

KNOTT BUILDING, DAYTON, 2, OHIO

This document is the property of the United States Government. It is furnished for the duration of the contract and shall be returned when no longer required, or upon recall by ASTIA to the following address: Armed Services Technical Information Agency, Document Service Center, Knott Building, Dayton 2, Ohio.

NOTICE: WHEN GOVERNMENT OR OTHER DRAWINGS, SPECIFICATIONS OR OTHER DATA ARE USED FOR ANY PURPOSE OTHER THAN IN CONNECTION WITH A DEFINITELY RELATED GOVERNMENT PROCUREMENT OPERATION, THE U. S. GOVERNMENT THEREBY INCURS NO RESPONSIBILITY, NOR ANY OBLIGATION WHATSOEVER; AND THE FACT THAT THE GOVERNMENT MAY HAVE FORMULATED, FURNISHED, OR IN ANY WAY SUPPLIED THE SAID DRAWINGS, SPECIFICATIONS, OR OTHER DATA IS NOT TO BE REGARDED BY IMPLICATION OR OTHERWISE AS IN ANY MANNER LICENSING THE HOLDER OR ANY OTHER PERSON OR CORPORATION, OR CONVEYING ANY RIGHTS OR PERMISSION TO MANUFACTURE, USE OR SELL ANY PATENTED INVENTION THAT MAY IN ANY WAY BE RELATED THERETO.

UNCLASSIFIED

Official Use

AIR FORCE MUSEUM

R. & M. No. 1778
(2088)

A.R.C. Technical Report, 1937

100.12 /
R+M /
1773

93/95



AIR MINISTRY

AERONAUTICAL RESEARCH COMMITTEE
REPORTS AND MEMORANDA

Note on the Design of Corners in Duct Systems

By

G. N. PATTERSON, PH.D.

Handwritten scribbles

Crown Copyright Reserved

FILE COPY

Return to

WRIGHT FIELD LIBRARY

Dayton, Ohio

LONDON: HIS MAJESTY'S STATIONERY OFFICE

Price 2s. 6d. net

Note on the Design of Corners in Duct Systems

By

G. N. PATTERSON, PH.D.

COMMUNICATED BY THE DIRECTOR OF SCIENTIFIC RESEARCH, AIR MINISTRY

Reports and Memoranda No. 1773

*8th October 1936**

SUMMARY.—This report is a critical résumé of research on the subject of corners in duct systems. No new experimental data are included.

A review of investigations on the relation between the resistance and the design of a corner shows that a corner may be designed to give a low resistance without the use of guide vanes. The corner must be rounded and high values chosen for both the ratio of the radius of curvature to the duct width and the ratio of height to width. For the best results the duct must not be terminated immediately after the corner. The loss around a 90° corner may be reduced to 15 per cent. of the velocity head if the ratio radius of curvature/duct width is 3 and the ratio height/width is 6 and the duct extended a length equal to four times the duct width beyond the corner.

A summary of research on the reduction of corner loss through the use of guide vanes is given, in which the dependence of corner loss on the gap/chord ratio, incidence and profile of the vanes is discussed. The development of vane profiles for corners of 30°, 45°, 60° and 90° through the application of aerodynamic theory is outlined. Tests on these vanes show that the loss around a 90° corner is 14 per cent. of the velocity head at a Reynolds number of 4×10^4 , where the Reynolds number is based on the mean velocity in the duct and the chord of the vane. Through the use of these vanes a corner in a duct may be designed to have a very low resistance.

1. *Introduction.*—A measure of the resistance of a corner in a duct is obtained from the loss of total head experienced by the air in passing around the corner. If the cross section of the duct is uniform, the loss of head is the drop in static pressure around the corner, which may be expressed as a fraction of the velocity head $\frac{1}{2} \rho \bar{w}^2$ in the form

$$\eta = \Delta p / \frac{1}{2} \bar{w}^2 \rho$$

where ρ is the density of air and \bar{w} is the mean velocity in the duct.

Experiment shows that the value of η depends upon the Reynolds number. An increase in the Reynolds number to ten times the original value will result in a reduction in the corner resistance to about half the initial value. It is necessary,

* R.A.E. Report, July, 1936.

therefore, to state the value of the Reynolds number at which η was determined. In the present report the duct systems considered and the η values obtained apply to a Reynolds number range varying from 10^4 to 10^5 .

I.—*Design of an Efficient Corner*

2. *Flow casts for various corners.*—In order that the motion of the air may be studied visually, a method of making casts of the flow forms for corners has been used by L. Wirt.¹ The flow lines are produced by the action of the air on a mixture of lamp black and oil which is placed on the inside walls of the corner. A cast showing the flow on the walls may be made by filling the corner with plaster of Paris and then removing the walls of the corner. Flow casts obtained in this way are shown in Fig. 1. The stream lines show that the flow is considerably disturbed at a corner and that the amount of disturbance depends upon the design of the corner.

The flow around a sharp corner is not of the uniform type indicated in Fig. 1 (a), for experiment shows that the actual flow of air is that shown in Fig. 1 (b). The central core of approaching air is projected against the outside wall of the turn at A. Part of the flow is reversed and a vortex pair produced, and the remainder continues downstream in a more uniform manner.

The rounded corner produces a different type of flow (Fig. 1 (c)). The stream lines diverge near the outside wall of the turn and converge on the inside wall. A rotation of the flow is, therefore, produced in both the plane in which the air is turned and the plane perpendicular to the axis of the corner, and the resulting motion takes place in the form of two spirals rotating in opposite directions.

The effect of changes of the corner dimensions on the flow is indicated in Fig. 1 (d). In the case of the rounded corner an improvement of the flow is obtained by making the curvature of the turn more gradual.

The flow conditions downstream from the corner on the inside wall of the turn are shown in Fig. 1 (e). The flow is stalled and a stagnation point exists some distance downstream from the corner. After the flow has passed the stagnation point it gradually assumes a more uniform distribution.

3. *Effect of changes of design on corner loss.*—(a) *Radius ratio.*—The radius ratio is the ratio of the radius of curvature of the centre line of the turn (R) to the width of the duct (D) measured in the same plane as R. The results of investigations on the effect of radius ratio on the loss around 90° corners by L. Wirt¹ for the case of square sections and by A. Hofmann² for circular sections are given in Fig. 2. These curves show that a reduction in the corner loss is obtained by increasing R and decreasing D, the section remaining square or circular as the case may be. For a 90° corner with square or circular section the loss can be made less than 30 per cent. if $R/D \geq 2.5$.

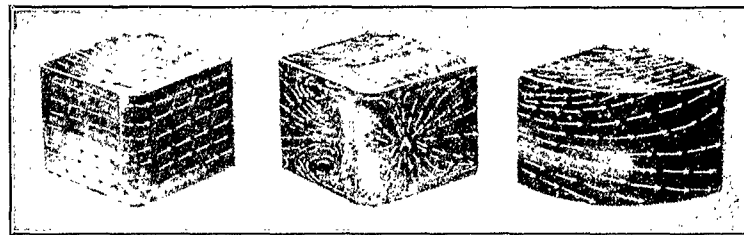

(a)

(b)

(c)

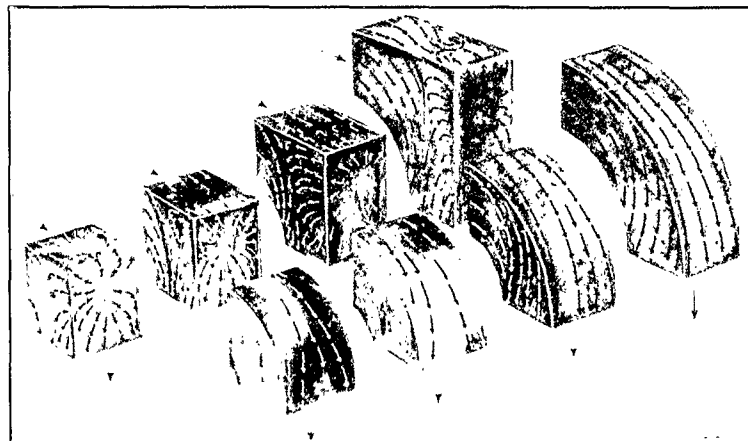

(d)



(e)

FIG. 1.—Flow Casts for Various Corners.

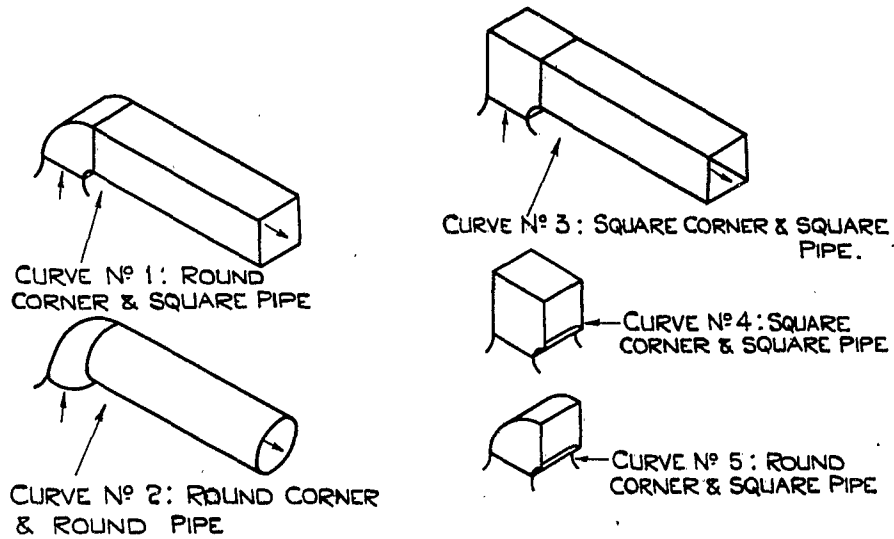
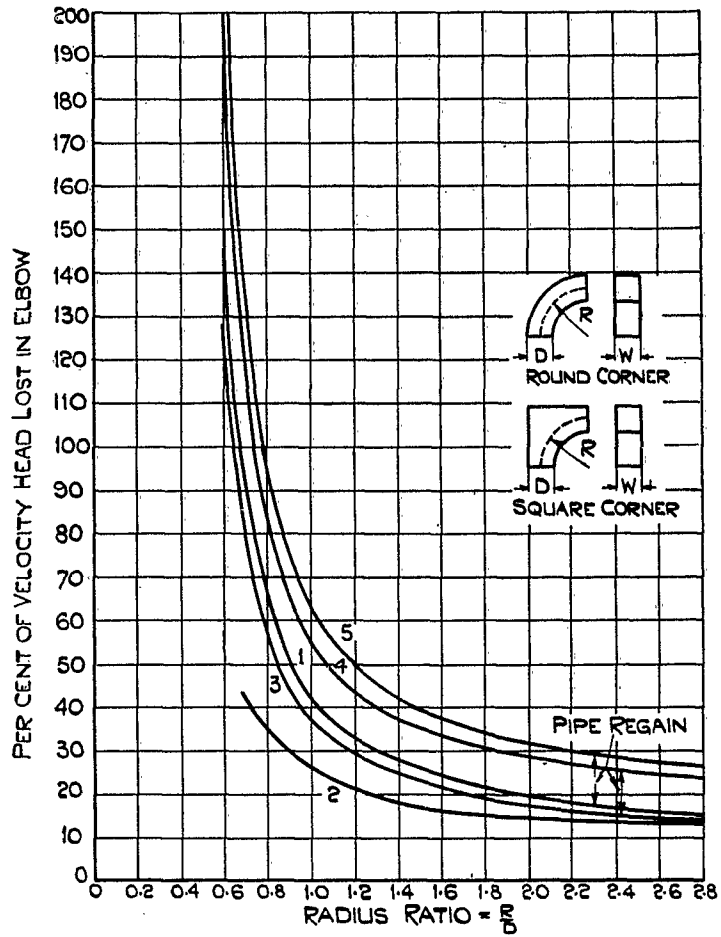

FIG. 2.—Effect of Radius Ratio on the Loss.

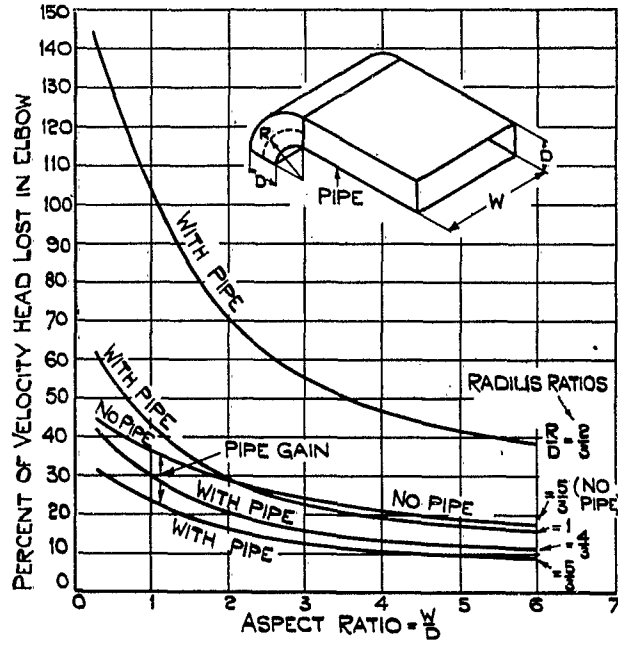
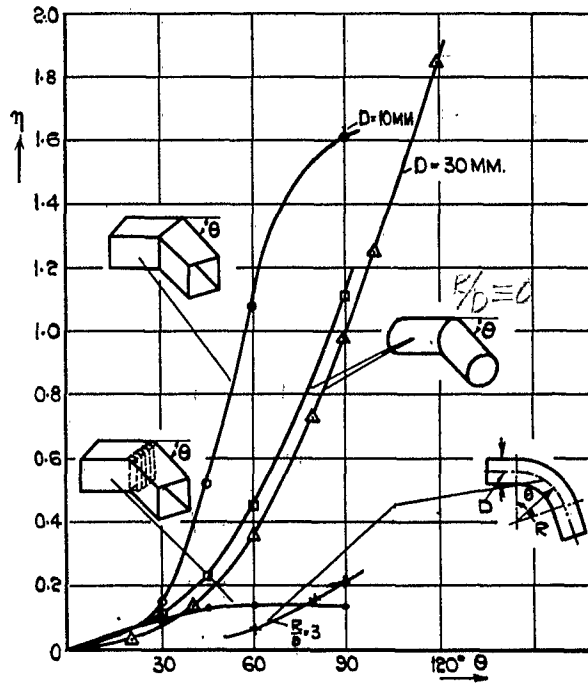

FIG. 3.



- Corner with Vanes. △ Circular Duct, Sharp Corner (Weisbach).
- + Circular Duct (Bouchayer). ⊙ Square Duct, Sharp Corner (Wirt).
- Circular Duct, Sharp Corner (Kirchbach).

FIG. 4.

Effect of Aspect Ratio and Angle of Deflection (θ) on the Loss.

The ratio R/D serves as a basis for comparing sharp and rounded corners, since for sharp corners R/D is very small and hence η is large and for rounded corners R/D is large and η small.

(b) *Aspect ratio.*—The effect of the ratio of height to width (W/D) on the loss around a 90° corner has also been investigated by Wirt. The results are summarised in Fig. 3 and they indicate that by increasing the ratio W/D from 1 to 6 it is possible to obtain reductions of about 50 per cent. in the corner loss.

As further indicated in Fig. 3, the combined effect of large aspect ratio and large radius ratio is to produce a corner loss of less than 20 per cent. of the velocity head.

(c) *Continuation of the duct after the corner.*—The results in Figs. 2 and 3 indicate that the loss around a 90° corner is appreciably higher if the duct is terminated immediately after the corner than is the case when the duct is extended beyond the corner. To obtain the best results the ratio of the length of duct following the corner to the duct width should be at least 4.

(d) *Angle of deflection.*—The results of the work of Weisbach³, Kirchbach⁴ and Bouchayer⁵ on the variation of η with the angle through which the air is turned by the corner (θ) for various corner designs are given in Fig. 4. As would be expected, the loss decreases as θ decreases. For a turn of 25° or less the corner loss is very small and below this angle of deflection corner design is not important. However, above this value of θ the variation of the loss with the angle of deflection is quite different for the various designs.

The curves in general show that the results obtained by Wirt which establish the effect of radius ratio on the corner loss for a turn of 90° , may be considered to hold in the range $0 \leq \theta \leq 90^\circ$. The results of Bouchayer show clearly that a rounded corner ($R/D = 3$) gives a much lower loss than a sharp corner for $\theta \leq 90^\circ$.

4. *Summary of the properties of an efficient corner.*—(a) The corner must be rounded and not sharp. The radius ratio should be made large. A consideration of Fig. 2 shows that for a 90° corner the radius ratio (radius of curvature/duct width) must be about 3 or more.

(b) A rectangular section of large aspect ratio is better than a circular section. Fig. 3 indicates that for a 90° corner the aspect ratio (height/width) should be about 6 or more.

(c) The duct should not be terminated immediately following the corner. The turn must be followed by a length of duct which is at least four times the duct width.

(d) If a 90° corner is designed according to the conditions given above, the corner loss will be of the order of 15 per cent. of the velocity head.

5. *Improvement of an inefficient corner.*—It may frequently occur in practice that other factors governing the design of a duct will prohibit the use of an efficient corner. Three cases may arise: (1) a corner with a good radius ratio but low aspect ratio; (2) a sharp turn with good aspect ratio; (3) a sharp corner with low aspect ratio. It has been found that, through the use of partitions, these inefficient corners may be improved by separating them into a number of efficient corners.

Case (1). (High radius ratio, low aspect ratio.)—An improved corner is produced by partitioning with circular guide surfaces so that each compartment so formed has a high aspect ratio. The improvement of the corner by this method is limited by the loss associated with the increase in surface area introduced by the separators and this loss increases as either the radius ratio or aspect ratio is increased. For this reason the loss around a 90° corner, which has been improved in this way, is not less than 30 per cent. of the velocity head.¹

Case (2). (Low radius ratio, high aspect ratio.)—Circular guide vanes, having a small surface area, may be used in this case. The number of vanes should be sufficient to give each separate compartment a good radius ratio. The minimum loss around a 90° corner of this type is about 20 per cent. of the velocity head.

Case (3). (Low radius ratio, low aspect ratio.)—Circular guide vanes may again be used to reduce the corner loss. The number of vanes is determined by the fact that each compartment must now have both a good radius ratio and a good aspect ratio. The minimum loss around a 90° corner of this kind is about 20 per cent.

The discussion for Case (3) shows that a corner of the type described in Case (1) may be improved by reducing the radius ratio and using vanes as in Case (3).

In Fig. 1 (a) is shown the great improvement in the flow through the use of guide vanes, and in Fig. 4 the large reduction in the loss around sharp corners in square ducts obtained with guide vanes is indicated.

The resistance of a corner fitted with vanes is closely related to the shape, dimensions, number and incidence of the vanes. These factors have been investigated experimentally and a review of the results follows.

II.—*Experimental Tests of Vane Designs*

6. *Description of the vane designs under test.*—An experimental investigation of various vane designs for a 90° corner has been carried out by Klein, Tupper and Green.⁶ A duct having a cross-section of 1.5 ft. \times 3 ft. was used and the experiments were carried out in the velocity range 30 to 80 ft./sec. The range of the Reynolds number (based on the chord of the vanes) was 10^4 to 10^5 .

Two 16-gauge sheet metal vanes (Vanes 1 and 2, Fig. 5) and two vanes of thick section (Vanes 3 and 4, Fig. 5) were tested. In each case the chord (c) of the vane was 6 in. The profile of Vane No. 1 is a circular arc with radius $\frac{2}{3}c$ joined tangentially to two straight lines inclined at 45° to the chord. The profile of Vane No. 2 is the arc of a quarter circle (radius $c/\sqrt{2}$). Vane No. 3 has a thick profile resembling to

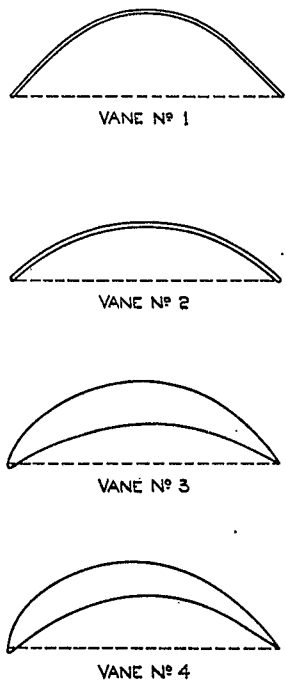

FIG. 5.—Vane Profiles for a 90° Corner.

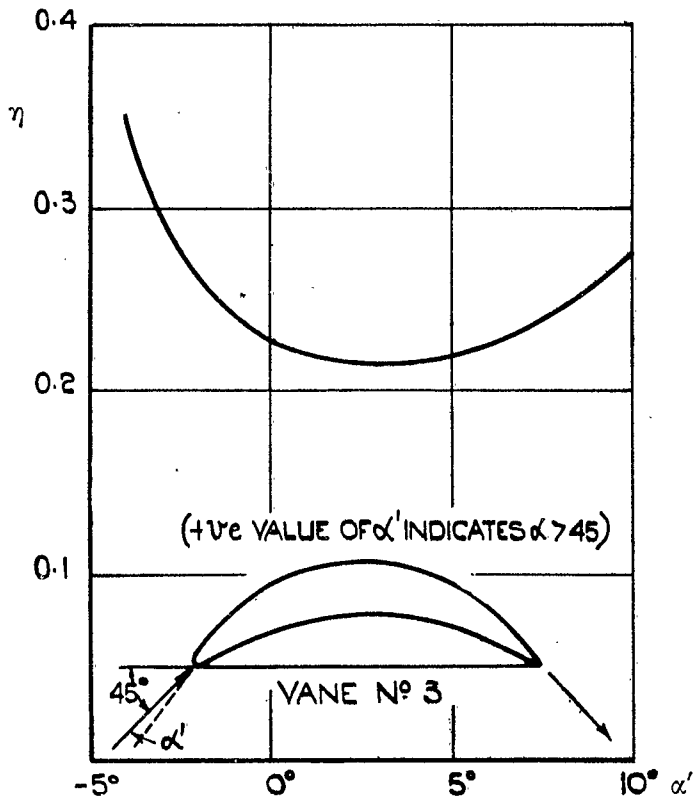

FIG. 6.—Variation of Corner Loss with Incidence. ($\alpha = 45^\circ + \alpha'$).

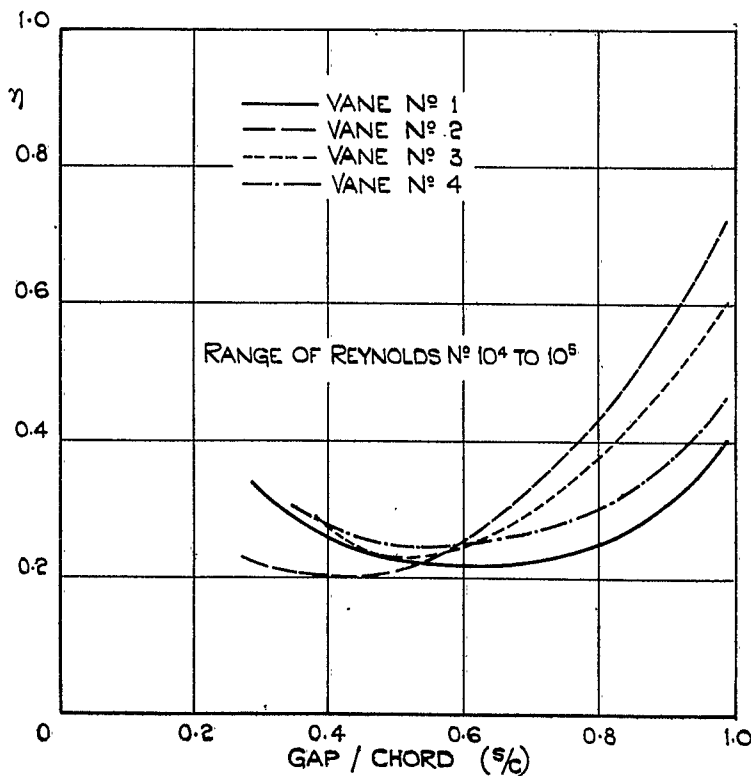

FIG. 7.—Variation of Corner Loss with the Gap/Chord Ratio.

some extent the shape of the vanes used in the Göttingen tunnel. The maximum thickness is near the centre of the chord. The profile of Vane No. 4 is a modification of a fore-shortened R.A.F. 30 section arranged along a circular arc, the maximum thickness being about $\frac{1}{3}c$ from the leading edge. The profile dimensions for Vanes 3 and 4 are given in the original paper.⁶

7. *Comparison of the results for each vane design.*—Tests carried out on these vanes indicate that the most uniform velocity distribution on the exit side of the corner was obtained with Vanes 2 and 3. This result is interesting since it indicates that a good velocity distribution is possible with either thin or thick sections.

The effect of incidence is the same for all the vanes and is illustrated by the tests on Vane No. 3 (Fig. 6). The incidence at which the minimum corner loss is obtained is not critical and is very near the position at which the inclination of the chord to the direction of the incident air is 45° . The effect of incidence on the exit flow is mainly to change the direction of flow. As the incidence is increased the air is deflected through a larger angle (θ). On the other hand, no appreciable improvement in the velocity distribution is obtained.

The most important factor governing the uniformity of the velocity distribution and the magnitude of the corner resistance is the ratio of the gap between the vanes to the chord, where the gap is measured along the corner diagonal. In general the velocity distribution improves continuously as the gap is reduced. For the corner loss, however, a definite minimum point is reached as the gap/chord ratio is decreased. The variation of the corner loss coefficient η with the gap/chord ratio for each vane is shown in Fig. 7. It is found that the minimum loss is lower for the thin vanes than for the thick vanes, though the difference is not very great. Vane No. 2 gives the lowest loss of 20 per cent. of the velocity head at a gap/chord ratio of 0.43.

8. *Effect of vane shape.*—The results for Vane No. 2 verify the statement in section 5 of this report that the loss around an inefficient 90° turn may be reduced to 20 per cent. of the velocity head through the use of circular guide vanes. It was also pointed out that this reduction of the corner loss could be accounted for by the improvement of the radius ratio and the aspect ratio of the corner. Since Vanes 1, 3 and 4 have not produced a loss lower than 20 per cent. it is clear that no further reduction of the corner loss can be attributed to the profiles chosen for these vanes.

9. *Other investigations.*—The work of R. G. Harris and R. A. Fairthorne⁷ and K. Frey⁸ on the reduction of corner loss through the use of vanes leads to results which are similar to those described above. The corner losses are still of a relatively high order so that the reduction in loss obtained by the various vanes tested is still essentially that resulting from the improvement of the aspect ratio and radius ratio.

The problem of vane shape has not been solved by any of the research described up to this point. All of these tests were carried out with vanes of a given shape, and no attempt was made to produce a method by which a profile suitable for a given deflection may be derived. This problem has been considered in detail by Keiber,⁹ and a review of his work follows.

III.—*Consideration of Vane Profile from the Point of View of Aerodynamic Theory*

10. *Circulation around a vane.*—The factor which determines the amount by which a fluid will be deflected is the circulation around each vane. The circulation which a vane must have for a given angle of deflection may be found in the following manner.

The assumption will be made that the circulation around a vane is concentrated at the centre of pressure. Each vane may then be replaced by a vortex having its centre coincident with the centre of pressure of the vane and having a vortex strength Γ equal to the circulation around a single vane. Let s be the distance between the vortices, which is the same as the gap between the vanes, and let θ be the given angle of deflection.

The flow around a corner fitted with vanes may, therefore, be represented by the superposition of (1) a uniform potential flow perpendicular to the corner diagonal, and (2) a flow due to a series of equally spaced vortices. Let w_1 , having the components u_1 and v_1 , be the velocity of the air approaching the cascade of vanes and let w_2 , with the components u_2 , v_2 , be the velocity of the air leaving the cascade (Fig. 8). At large distances from the vortices the following conditions hold.

(1) The velocity components u_1 and u_2 are due to the parallel potential flow only, and $u_1 = u_2$.

(2) The velocity components v_1 and v_2 are due to the system of vortices only, and $v_1 = -v_2$.

Consider a region enclosing a single vortex as shown in Fig. 8. The width of the region is s and it extends a large distance $l/2$ on each side of the vortex. Then the line integral of the velocity along the boundary enclosing this region will be equal to the vortex strength Γ . Thus:

$$\Gamma = sv_1 + \int_{-l/2}^{l/2} u dl - sv_2 - \int_{-l/2}^{l/2} u dl$$

$$\text{or} \quad \Gamma = s(v_1 - v_2) = 2sv_1 = 2sw \sin \theta/2 \quad \dots \quad (1)$$

where w is written for $|w_1|$ or $|w_2|$.

CORNER
DIAGONAL

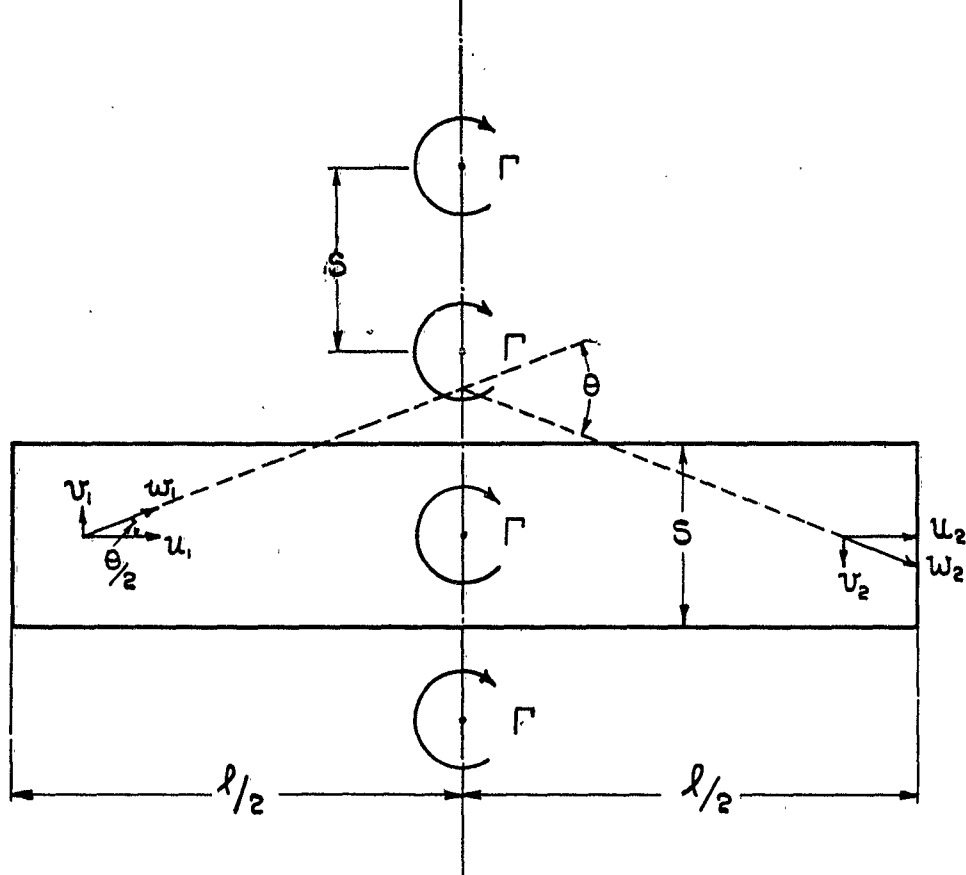

FIG. 8.—Vortex System replacing the Cascade of Vanes.

11. *Development of a vane profile having the required circulation Γ .*—Consider an aerofoil in a uniform potential flow moving parallel to the axis of x . The lift on the aerofoil is

$$L = \rho U \Gamma' = C_L \cdot \frac{1}{2} \rho U^2 \cdot c$$

where U is the velocity of the undisturbed flow, Γ' is the circulation around the aerofoil, C_L is the lift coefficient, c is the chord of the aerofoil and ρ is the density of the fluid medium. The circulation around the aerofoil may, therefore, be written

$$\Gamma' = \frac{1}{2} C_L U c \quad \dots \quad \dots \quad \dots \quad \dots \quad (2)$$

This aerofoil, which is in a plane denoted by z , may be transformed to a field of curved flow in the ζ plane in which the fluid is deflected through the angle θ . This is accomplished by a method of transformation developed by Betz.¹⁰ Since the

circulation remains unchanged during the transformation, then Γ' must equal Γ , the circulation required to produce the deflection θ in the ζ plane. Therefore, the transformation must be such that :

$$\frac{1}{2}C_L U c = 2s w \sin \theta / 2 \quad \dots \quad \dots \quad \dots \quad \dots \quad (3)$$

It will be seen from equation (3) that, for a given set of conditions (s , w and θ) in the ζ plane, two of the quantities in the z plane may be fixed arbitrarily. The scale of the network of orthogonal lines in the z and ζ planes may be so chosen that

$$U = w.$$

Thus, the network at large distances from the profile in the z and ζ planes is the same. In order that the skin friction loss associated with the additional surface area introduced by a system of vanes may be a minimum, the gap s must be large, so that the profile in the z plane must be such that C_L is as high as possible. The maximum C_L for most aerofoils¹¹ is not more than 1.4. The value $C_L = 1.35$ is therefore chosen.

The profile which is selected for the z plane is that deduced theoretically by Birnbaum and Prandtl¹² (Fig. 9). It has the following equation for the lift coefficient

$$C_L = 2 \pi \sin (\alpha + \beta - \frac{1}{2} \gamma)$$

and for the pitching moment coefficient

$$C_m = \frac{\pi}{2} \sin (\alpha + 2 \beta - \frac{5}{4} \gamma)$$

where $\beta = \frac{1}{4} (\psi + \varphi)$, $\gamma = \frac{1}{4} (\psi - \varphi)$ and ψ is the angle between the chord and the tangent to the profile at the leading edge, φ is the angle between the chord and the tangent to the profile at the trailing edge and α is the angle of incidence of the aerofoil.

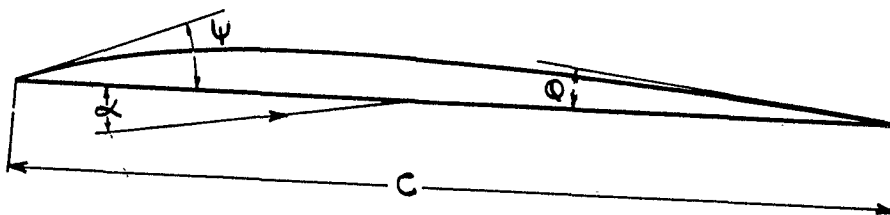

FIG. 9.—Birnbaum Aerofoil.

The choice of $\psi = 12^\circ$, $\varphi = 6^\circ$ gives $C_L = 1.35$ at the reasonable incidence of $\alpha = 8^\circ 40'$. The pitching moment coefficient becomes 0.428 and the position of the centre of pressure is given by :

$$\frac{x}{c} = \frac{C_m}{C_L} = 0.317 .$$

In Fig. 10 is shown the original and transformed profiles (full lines) for $\theta = 90^\circ$. The position of the centre of the vortex required to produce the deflection through 90° in the ζ plane is at 0. The Birnbaum aerofoil is placed in the z plane with its theoretical centre of pressure at the corresponding point 0. The profile obtained by the transformation is found to have an incidence of $64^\circ 45'$. Experimental tests by Keiber on this vane profile showed that the minimum corner loss is about 14 per cent. of the velocity head at a Reynolds number of 4×10^4 and an incidence of $56^\circ 30'$.

In order to obtain better agreement between the theoretical and experimental incidence angles, tests were carried out on the transformed profile in the ζ plane (full line, Fig. 10) to determine the position of the centre of pressure. It was found to be at Z (ζ plane, Fig. 10). If, therefore, the Birnbaum profile in the z plane is displaced so that the transformed point Z coincides with 0, then a second transformation produces a profile (broken line, ζ plane, Fig. 10) having an incidence of 59° . The minimum corner loss around a 90° corner fitted with vanes having this profile was again found to be about 14 per cent. of the velocity head at a Reynolds number of 4×10^4 and an incidence of $56^\circ 30'$.

The previous transformations have been carried out on the assumption that the circulation around a vane could be regarded as concentrated at the centre of pressure. If the circulation required to deflect the flow through an angle θ is calculated from the actual distribution of circulation without the use of vortices, a different transformation results. The profile obtained by this third transformation from the original Birnbaum aerofoil (Fig. 11) has an incidence of 56° . Tests on vanes having this profile showed that the minimum corner loss was about 14 per cent. of the velocity head at a Reynolds number of 4×10^4 and an incidence of 55° . In this case there is good agreement between the experimental and theoretical incidences.

A review of the above results shows that, provided each vane is set at the incidence found experimentally to give the minimum corner loss, the three profiles are equivalent. The velocity distribution behind the vanes and the minimum corner loss were found by Keiber to be almost the same in all three cases. Vane profiles, which are obtained by the approximate method based on the assumption that the circulation around a vane is concentrated at the theoretical centre of pressure, are therefore considered to be acceptable, but the angle of incidence corresponding to minimum corner loss must be that determined experimentally in each case.

12. *Profiles obtained by the approximate method for corners of 90° , 60° , 45° and 30° .*—The Birnbaum profile may be transformed to a curved flow having an angle of deflection less than 90° . The profiles for corners of 90° , 60° , 45° and 30° as

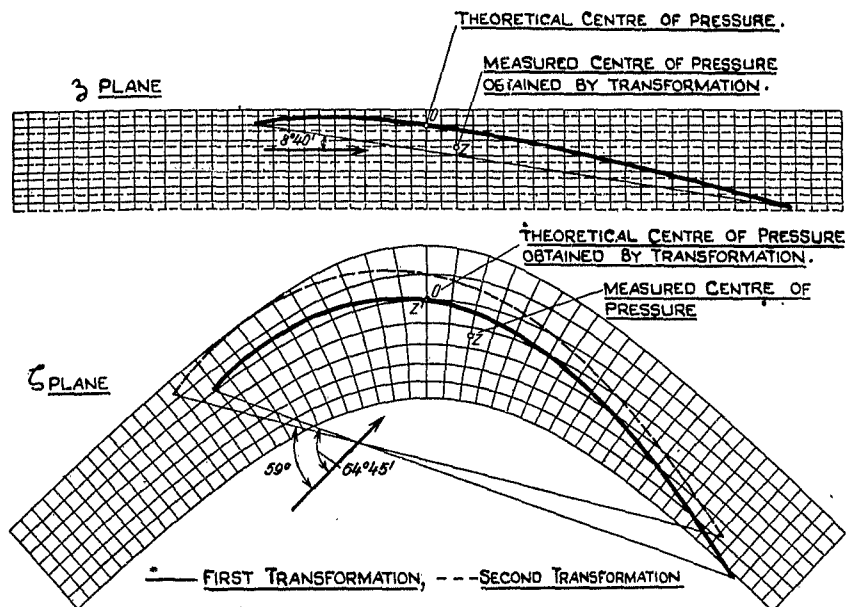

FIG. 10.—Vane Profiles for a 90° Corner obtained by the First and Second Transformations.

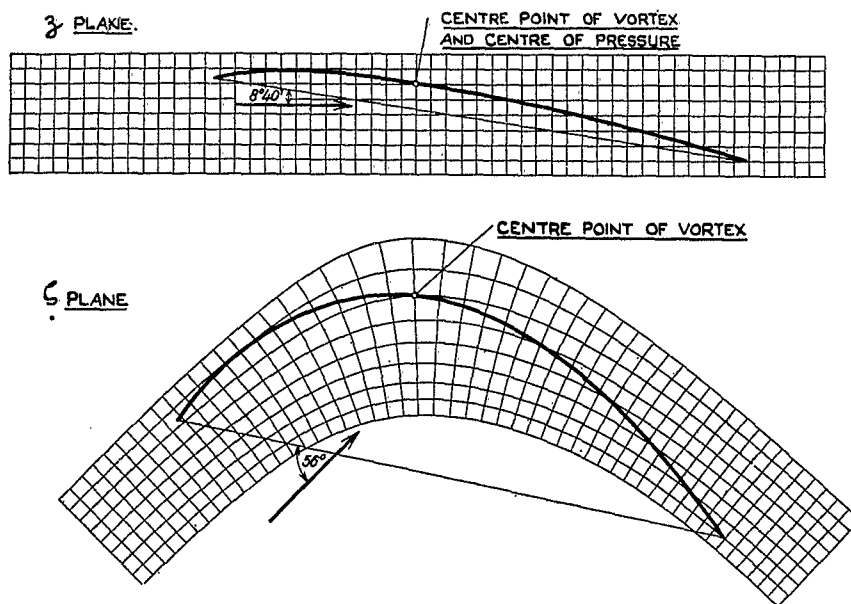

FIG. 11.—Vane Profile for 90° Corner obtained by the Third Transformation.

obtained by the approximate method are shown in Fig. 12. A value $C_L = 1.00$ has been chosen for the 45° and 30° corners. The incidences corresponding to minimum corner loss as found experimentally are indicated for each profile. The dimensions of these profiles referred to the chord are given in Table 1.

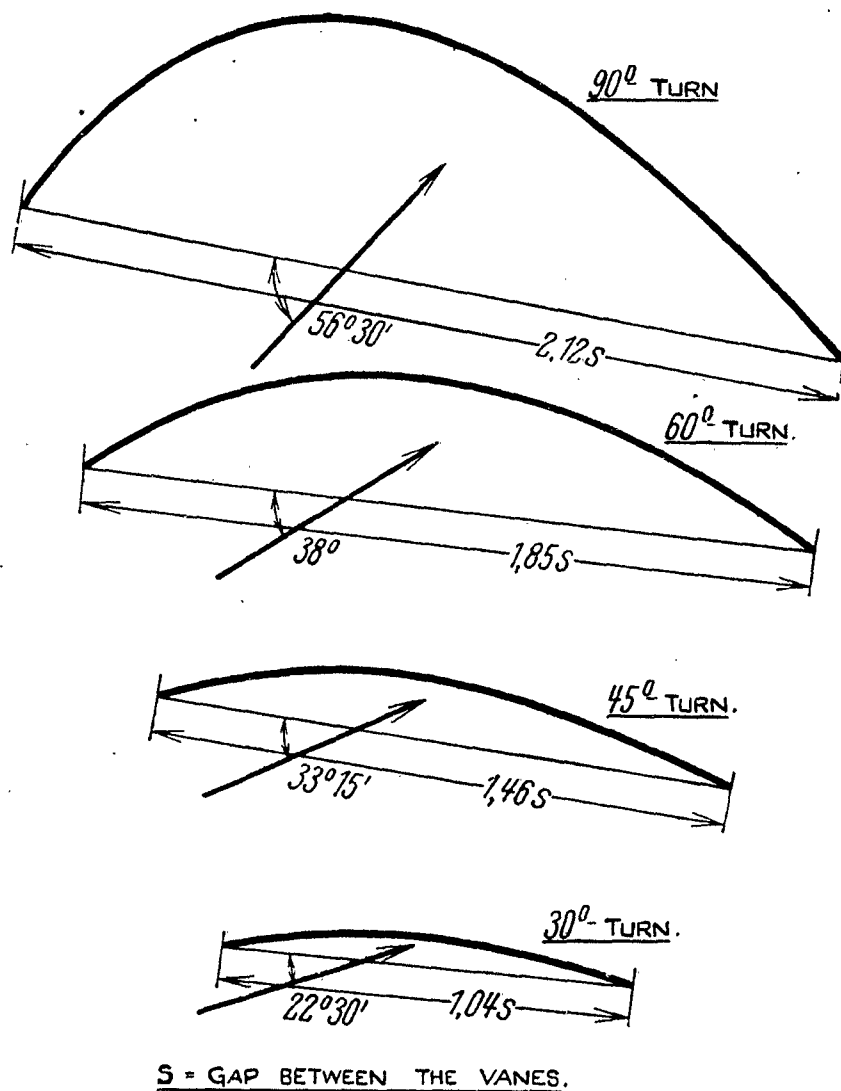

FIG. 12.—Vane Profiles for Various Corners obtained by the First Transformation.

From a consideration of equation (3) the gap/chord ratio for each of these profiles may be determined. The Betz transformations in each case are such that the chord of the original Birnbaum aerofoil in the z plane and the chord of the transformed profile in the ζ plane are approximately the same. Equation (3) then becomes :

$$s/c = \frac{1}{4} C_L \operatorname{cosec} \theta / 2 \quad \dots \quad \dots \quad \dots \quad \dots \quad (4)$$

where s/c is the gap/chord ratio for the system of vanes, θ is the angle of deflection and C_L is the lift coefficient of the original Birnbaum aerofoil in the z plane. The chord of each profile in Fig. 12 is given in terms of the gap as found from equation (4).

A summary of the results of Keiber's experiments with the various transformed profiles described above at a Reynolds number of 4×10^4 is given in Table 2. The losses around combinations of two 90° corners, two 45° corners and three 60° corners are also indicated. These results show that vanes having the profiles shown in Fig. 12 produce a reduction in corner loss which is the result of the combination of good aspect ratio, radius ratio and profile shape.

13. *Magnitude of the chord—scale effect.*—The effect of increasing the Reynolds number to values such as those which apply to wind tunnels is to reduce the corner loss below the values quoted above. An investigation by Klein, Tupper and Green⁶ on scale effect showed that the loss around a 90° corner decreased from 27 per cent. to 20 per cent. when the chord of the vanes was increased from $1\frac{1}{16}$ in. to 6 in. This result indicates that vanes with a large chord should be used in preference to those with a small chord.

LIST OF REFERENCES

- | <i>No.</i> | <i>Author.</i> | <i>Title.</i> |
|------------|--|--|
| 1 | L. Wirt | New Data for the Design of Elbows in Duct Systems. General Electric Review, Vol. 30, No. 6 (1927), p. 286. |
| 2 | A. Hofmann | The Energy Loss around 90° Bends in Tubes of Uniform Cross-section. Mitt. Hydr. Inst. Techn. Hochschule, München, Vol. 3. (1929.) |
| 3 | J. Weisbach | Experimental Hydraulics, p. 148, Freiberg. (German text-book.) |
| 4 | H. Kirchbach | Energy Loss in Elbows. Mitt. Hydr. Inst. Techn. Hochschule, München, Vol. 3. (1929.) |
| 5 | M. A. Bouchayer | The Loss of Energy in Duct Elbows and Branches. Hydroelectr. Kongress, Grenoble (1925); Engineering (1925), II, p. 241. |
| 6 | G. J. Klein, K. F. Tupper and J. J. Green. | The Design of Corners in Fluid Channels. Canadian Journal of Research, Vol. 3. (1930.) |
| 7 | R. G. Harris and R. A. Fairthorne. | Wind Tunnel Experiments with Infinite Cascades of Aerofoils. R. & M. 1206. (1928-29.) |
| 8 | Kurt Frey | Reduction of Aerodynamical Losses in Channels by means of Guide Surfaces. Forschung., Vol. 5, No. 3. (May-June, 1934.) |
| 9 | Keiber | Ingénieur Archiv, Vol. 3, No. 5. (1932.) |
| 10 | A. Betz | Ingénieur Archiv, 2 (1931), p. 359. |
| 11 | A. Betz | Aerofoils and Hydraulic Machines. Handbuch der Physik, Vol. VII (1927), Chapter 4. |
| 12 | W. Birnbaum | Z.A.M.M., 3 (1923), p. 290. |

TABLE 1

Profile dimensions for the vanes shown in Fig. 12

x/c	y/c			
	90°	60°	45°	30°
0.00	0.000	0.000	0.000	0.000
0.05	0.087	0.041	—	—
0.10	0.154	0.074	0.044	0.031
0.15	0.200	0.100	—	—
0.20	0.236	0.124	0.075	0.051
0.25	0.262	0.140	—	—
0.30	0.277	0.153	0.094	0.067
0.35	0.284	0.161	—	—
0.40	0.284	0.166	0.105	0.071
0.45	0.283	0.168	—	—
0.50	0.273	0.164	0.103	0.071
0.55	0.260	0.157	—	—
0.60	0.242	0.151	0.094	0.067
0.65	0.219	0.142	—	—
0.70	0.192	0.129	0.078	0.055
0.75	0.167	0.111	—	—
0.80	0.137	0.096	0.058	0.043
0.85	0.104	0.072	—	—
0.90	0.071	0.048	0.030	0.024
0.95	0.037	0.026	—	—
1.00	0.000	0.000	0.000	0.000

 x = distance along chord (c), y = distance perpendicular to chord.

TABLE 2

Results of tests on the improved vane profiles

Angle of deflection (θ).	Shape of profile.	Incidence (α).		Resistance coefficient (η).	
		Theoretical.	Experimental.	With vanes.	Without vanes.
90°	Fig. 10 (full line)	64° 15'	56° 30'	0.134	1.63
90°	Fig. 10 (dotted line)	59°	56° 30'	0.134	1.63
90°	Fig. 11	56°	55°	0.138	1.63
60°	Fig. 12	43°	38°	0.146	1.08
45°	Fig. 12	33° 15'	33° 15'	0.142	0.53
30°	Fig. 12	22° 30'	22° 30'	0.100	0.15
2 × 90°	Fig. 10 (dotted line)	59°	56° 30'	0.260	—
2 × 45°	Fig. 12	33° 15'	33° 15'	0.266	—
3 × 60°	Fig. 12	43°	38°	0.304	—

Reynolds number = 4×10^4 .



*Information Centre
Knowledge Services*
[dstl] Porton Down
Salisbury
Wiltshire
SP4 0JQ
22060-6218
Tel: 01980-613753
Fax 01980-613970

Defense Technical Information Center (DTIC)
8725 John J. Kingman Road, Suit 0944
Fort Belvoir, VA 22060-6218
U.S.A.

AD#: AD093195

Date of Search: 12 June 2008

Record Summary: DSIR 23/5879

Title: Unsteady Design of Corners in Duct Systems
Availability Open Document, Open Description, Normal Closure before FOI Act: 30 years
Former reference (Department) ARC 2628
Held by The National Archives, Kew

This document is now available at the National Archives, Kew, Surrey, United Kingdom.

DTIC has checked the National Archives Catalogue website (<http://www.nationalarchives.gov.uk>) and found the document is available and releasable to the public.

Access to UK public records is governed by statute, namely the Public Records Act, 1958, and the Public Records Act, 1967.

The document has been released under the 30 year rule.

(The vast majority of records selected for permanent preservation are made available to the public when they are 30 years old. This is commonly referred to as the 30 year rule and was established by the Public Records Act of 1967).

This document may be treated as UNLIMITED.