

UNCLASSIFIED

AD NUMBER

AD102024

CLASSIFICATION CHANGES

TO: UNCLASSIFIED

FROM: CONFIDENTIAL

LIMITATION CHANGES

TO:
Approved for public release; distribution is unlimited.

FROM:
Distribution authorized to U.S. Gov't. agencies and their contractors;
Administrative/Operational Use; 15 MAY 1956.
Other requests shall be referred to Office of Naval Research, 875 N. Randolph St., Arlington, VA 22203.

AUTHORITY

ONR ltr 28 Jul 1977 ; ONR ltr 28 Jul 1977



AD 102024

Armed Services Technical Information Agency

Reproduced by

DOCUMENT SERVICE CENTER

KNOTT BUILDING, DAYTON, 2, OHIO

This document is the property of the United States Government. It is furnished for the duration of the contract and shall be returned when no longer required, or upon recall by ASTIA to the following address: Armed Services Technical Information Agency, Document Service Center, Knott Building, Dayton 2, Ohio.

NOTICE: WHEN GOVERNMENT OR OTHER DRAWINGS, SPECIFICATIONS OR OTHER DATA ARE USED FOR ANY PURPOSE OTHER THAN IN CONNECTION WITH A DEFINITELY RELATED GOVERNMENT PROCUREMENT OPERATION, THE U. S. GOVERNMENT THEREBY INCURS NO RESPONSIBILITY, NOR ANY OBLIGATION WHATSOEVER; AND THE FACT THAT THE GOVERNMENT MAY HAVE FORMULATED, FURNISHED, OR IN ANY WAY SUPPLIED THE SAID DRAWINGS, SPECIFICATIONS, OR OTHER DATA IS NOT TO BE REGARDED BY IMPLICATION OR OTHERWISE AS IN ANY MANNER LICENSING THE HOLDER OR ANY OTHER PERSON OR CORPORATION, OR CONVEYING ANY RIGHTS OR PERMISSION TO MANUFACTURE, USE OR SELL ANY PATENTED INVENTION THAT MAY IN ANY WAY BE RELATED THERETO.

NOTICE: THIS DOCUMENT CONTAINS INFORMATION AFFECTING THE NATIONAL DEFENSE OF THE UNITED STATES WITHIN THE MEANING OF THE ESPIONAGE LAWS, TITLE 18, U.S.C., SECTIONS 793 and 794. THE TRANSMISSION OR THE REVELATION OF ITS CONTENTS IN ANY MANNER TO AN UNAUTHORIZED PERSON IS PROHIBITED BY LAW.

107 024

Contract No. Nonr-1675(00)

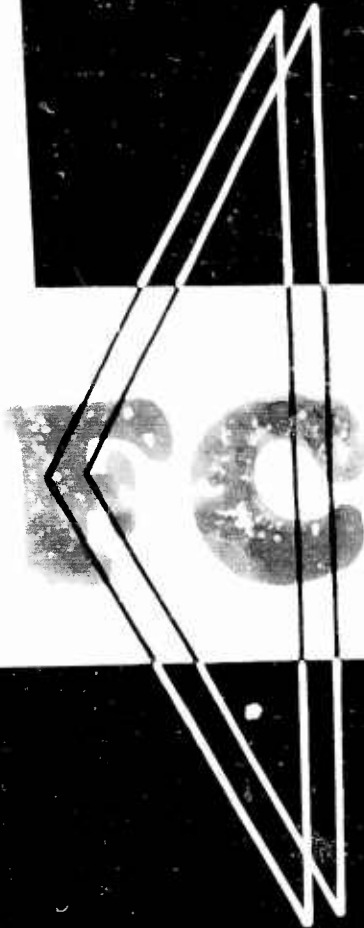

RAC

**DUCTED PROPELLER
ASSAULT TRANSPORT**

Performance

Report No. D181-945-004

15 May 1956

BELL Aircraft CORP.

~~CONFIDENTIAL~~

BELL Aircraft CORPORATION
BUFFALO 5, NEW YORK

TECHNICAL DATA

NOTICE

This document contains information affecting the national defense of the United States within the meaning of the Espionage Laws, Title 18, U. S. C., Section 793 and 794. The transmission or the revelation of its contents in any manner to an unauthorized person is prohibited by law.

BY *J.M. Zabinsky* & *M.M. Laszewski* DATE . 15 May 1956
 CHECKED *J.M. Zabinsky & M.M. Laszewski* DATE . 15 May 1956
 APPROVED *James A. O'Malley, Jr.* DATE . 15 May 1956
 APPROVED *P.C. Emmons* DATE . 15 May 1956
 James A. O'Malley, Jr., Project Aerodynamicist
 P.C. Emmons, Chief Aerodynamicist

CONTRACT NO. Nonr-1675(00)

NO. OF PAGES

REPORT NO. D181-945-004	MODEL
Ducted Propeller Assault Transport Study	
PERFORMANCE	

REVISIONS

DATE	PAGE NO.
NOTICE	
Reproduction in whole or in part is permitted for any purpose of the United States Government.	
56AA	3729

This document has been reviewed in accordance with OPM FPMR 5610.17, paragraph 5. The security classification assigned here to is correct.

Date: *7/10/52*
By direction of *W.C. Fortune*
Chief of Naval Research (Code 441)

~~CONFIDENTIAL~~



THE ATTACHED DOCUMENT CONTAINS

CONFIDENTIAL INFORMATION AND AS SUCH IT MUST BE

RECORDED—On a Classified Document Register and marked with the assigned Bell Identification Number when you originate, reproduce or receive a classified document. See Bell Aircraft Corporation Security Manual.

STORED—Minimum requirements call for a steel file cabinet equipped with a steel bar and three-position combination dial type padlock.

TRANSMITTED—In double sealed opaque containers. The classified information shall be protected from direct contact with the inner cover by a sheet or by folding inward. Only the inner container shall indicate the classification. Both the inner and outer cover shall indicate the addressee and addressor.

By U.S. registered mail, air or surface, by appropriately cleared messenger designated by the company or by protected commercial express, air or surface, under billing which assures the highest degree of protective handling.

RECEIVED FOR—Classified Document Receipt, Form G6-32, optional with sender, may be enclosed within the inner wrapper for all CONFIDENTIAL matter dispatched outside Bell Aircraft Corporation Niagara Frontier Division facilities.

Hand Receipt, Form G6-42, optional with sender, may be used for all transmittals of CONFIDENTIAL matter between individuals or by company mail service within Bell Aircraft Corporation Niagara Frontier Division facilities.

ADDITIONAL SECURITY INFORMATION

- (1) Bound documents—Classified books or pamphlets, the pages of which are permanently and securely bound together so that the pages thereof cannot be removed without damage or mutilation, shall be marked with the classification assigned to the document at the top and bottom on the outside of the front cover and back cover, title, first and last pages and all printed, typed, or written pages which contain classified information, including the reverse side, if used.
- (2) Correspondence and unbound documents—Correspondence and other documentary material not permanently and securely bound together shall be marked with the appropriate classification at the top and bottom of each page which contains classified information, including the cover page, if used. The marking shall be placed so that it will not be hidden from view when the pages are clipped or stapled together.
- (3) Letters of Transmittal.—A letter transmitting defense information shall be marked with a classification at least as high as its highest classified inclosure. Letters of Transmittal, when appropriate, shall indicate that upon removal of classified inclosures such letters will be downgraded or declassified.
- (4) National Defense Stamp—Documents containing classified defense information furnished authorized persons other than those of, or in the employ of, agencies of the Department of Defense shall bear a notation substantially as follows.

“This document contains information affecting the national defense of the United States, within the meaning of the Espionage Laws, Title 18, U.S.C., Sections 793 and 794, the transmission or revelation of which in any manner to an unauthorized person is prohibited by law.”
- (5) “Restricted Data”—In addition to the markings prescribed above, “Restricted Data” will be marked in capital letters, “Restricted Data—Atomic Energy 1954” not less than ¼ inch in height.

CONFIDENTIAL
BELL Aircraft CORPORATION

FOREWORD

Contract Nonr-1675 (00) was awarded to Bell Aircraft Corporation by the Office of Naval Research under sponsorship of the Army Transportation Corps. This is one of a series of five study contracts let to investigate the application of various schemes to the design of Vertical Take-off and Landing (VTOL) or Short Take-off (STO) Assault Transport Aircraft.

The particular field of investigation at Bell Aircraft is the application of ducted propeller propulsion systems to the design of aircraft capable of performing the Assault Transport mission. The results of the investigation are presented in the following listed reports:

<u>TITLE</u>	<u>REPORT NUMBER</u>
Summary Report	D181-945-001
Design Report	D181-945-002
Survey of the State of the Art	D181-945-003
Performance	D181-945-004
Stability and Control	D181-945-005
Duct and Propeller Analysis	D181-945-006
Preliminary Structural Analysis	D181-945-007
Standard Aircraft Characteristics Charts	D181-945-008

This document has been reviewed in accordance with OPNAVINST 5510.17, paragraph 5. The security classification assigned hereto is correct.

Date: 7/30/56

By direction of
Chief of Naval Research (Code 461)

ABSTRACT

This report contains the results of a feasibility study of the performance of ducted propeller transport aircraft capable of performing the assault transport mission with vertical take-off and landing. The analysis has considered conventional performance items as well as the items of special performance pertinent to vertical take-off and landing and short take-off. The work was not required to comply with detailed specifications but the intent of MIL-C-5011A was followed where particular requirements for the study were not written. A parametric study was made to determine a range of aspect ratio and wing loading to be used in the design of these aircraft. A complete analysis of two aircraft was made to compare an airplane designed for the basic mission with one which had a greater potential. Both were approximately the same gross weight and configuration and differed in the size and power loading of the ducted propellers, which resulted in different level flight thrust and drag. The classical performance and mission capabilities of these two airplanes are presented and compared, under conditions of vertical and short take-off. The analysis of vertical take-off and landing determined useable and optimum thrust to weight ratios at take-off. Time histories of the take-off and landing flight paths are presented. The ability of the airplane to perform missions which include extended hovering was investigated. The ability of the airplane to make a short take-off was explored and curves of take-off distance as a function of the overload are presented as well as the increased range capability resulting from using fuel for this overload. An investigation of emergency operation in level flight

CONFIDENTIAL
BELL *Aircraft* CORPORATION

and during take-off and landing was made. The study was made to determine the feasibility of a VTOL ducted propeller assault transport. As a result, emphasis has been given to the special features which the concept embodies.

TABLE OF CONTENTS

<u>Section</u>	<u>Page</u>
Summary and Conclusions	1
Introduction	13
I. Best Configuration Highlights (D181-960-009).	14
A. Classical Performance	15
B. Drag of the Ducts	16
C. Mission Radii	16
D. Ferry Range	21
E. Emergency Operation - Level Flight	23
F. Vertical Take-Off and Landing	24
G. Short Take-Off.	26
H. Emergency Operation - Hovering and Transition	27
II. Study Configuration Analysis.	53
A. Configuration Description	53
B. Performance Parameters.	54
C. Performance	56
1. Classical Performance	58
2. Basic Mission	60
D. Vertical Take-Off Study	62
III. Descriptions of the Specific Configurations (D181-960-007, D181-960-009, & D181-960-011).	88
A. Physical Characteristics.	88
B. Ducted Propeller Characteristics.	92
C. Aerodynamic Coefficients.	95
D. Level Flight Performance.	97
E. Radius and Range.	98
Symbol List	128
Reference List.	130

CONFIDENTIAL
BELL *Aircraft* CORPORATION

LIST OF FIGURES

<u>Figure No.</u>	<u>Title</u>	<u>Page</u>
1	Classical Performance - G.W. = 60,000#, D181-960-009	11
2	Mission Radii	12
3	Configuration - D181-960-009	29
4	Classical Performance - D181-960-009	30
5	Shroud Drag Comparison - D181-960-009	31
6	Shroud Drag - D181-960-009	32
7	Radius and Hovering Time - VTO - D181-960-009	33
8	Radius and Hovering Time - 400 ft. Ground Roll - D181-960-009.	34
9	Radius and Hovering Time - 800 ft. Ground Roll - D181-960-009.	35
10	Ferry Range vs. Cruise Altitude - D181-960-009	36
11	Ferry Range vs. Speed - 30,000 ft. Altitude - D181-960-009 . .	37
12	Range and Hovering Time - D181-960-009	38
13	Emergency Operation Reduced Power - Sea Level - D181-960-009 .	39
14	Emergency Operation Reduced Power - h = 10,000 ft. D181-960-009	40
15	Emergency Operation Reduced Power - h = 20,000 ft. D181-960-009	41
16	Emergency Operation Reduced Power Climb - D181-960-009	42
17	Vertical Take-Off and Transition - D181-960-009.	43
18	Vertical Take-Off and Transition in 40 Knot Wind D181-960-009	44
19	Landing Performance, G.W. = 50,000 lb. - D181-960-009	45
20	Landing Performance, G.W. = 70,000 lb. - D181-960-009	46
21	Power Off Stall Speed - D181-960-009	47
22	Short Take-Off - Ground Roll vs. Thrust Angle - D181-960-009 .	48

LIST OF FIGURES (Cont'd)

<u>Figure No.</u>	<u>Title</u>	<u>Page</u>
23	Ground Roll vs. T/W	49
24	Take-Off Distance - D181-960-007 and 009	50
25	Engine Failure During Hovering - D181-960-009	51
26	Equilibrium Power Required - D181-960-009	52
27	Study Configuration - D181-960-001.	65
28	Lift and Drag Coefficient - D181-960-001.	66
29	Drag Polar - Variable Aspect Ratio - D181-960-001	67
30	Drag Polar Variable Wing Area - D181-960-001.	68
31	Power Available - Wright T49-W-1.	69
32	(a) Fuel Flow - Wright T49-W-1	70
	(b) Residual Thrust - Wright T49-W-1	70
33	Preliminary Performance - Preliminary Configuration	71
34	Rate of Climb - Variable Aspect Ratio	72
35	Rate of Climb - Variable Wing Area	73
36	Rate of Climb - Variable Gross Weight	74
37	Range in Climb - Variable Aspect Ratio	75
38	Fuel to Climb - Variable Aspect Ratio	75
39	Absolute Ceiling - Variable Aspect Ratio	75
40	Range in Climb - Variable Wing Area	76
41	Fuel to Climb - Variable Wing Area	76
42	Absolute Ceiling - Variable Wing Area	76
43	Range in Climb - Variable Wing Area	77
44	Fuel to Climb - Variable Wing Area	77
45	Absolute Ceiling - Variable Wing Area	77

LIST OF FIGURES (Cont'd)

<u>Figure No.</u>	<u>Title</u>	<u>Page</u>
46	Cruise Parameter - Variable Aspect Ratio	78
47	Cruise Parameter Variable Wing Area.	79
48	Cruise Parameter - Variable Gross Weight	80
49	Total Fuel to Complete Basic Mission	81
50	Weight of Wing and Fuel for Basic Mission. Variable Aspect Ratio	82
51	Fuel vs. Wing Loading.	83
52	Mission Fuel Required vs. Wing Loading-Variable Gross Weight .	84
53	Vertical Take-Off Performance.	85
54	Vertical Take-Off Performance - Altitude and Acceleration. . .	86
55	Vertical Take-Off and Transition - Study Configuration	87
56	Configuration - D181-960-007	104
57	Configuration - D181-960-009	105
58	Configuration - D181-960-011	106
59	Power Available - Rolls Royce RB-109	107
60	Power Available - Allison 550-B1	108
61	(a) Residual Thrust - Rolls Royce RB-109	109
	(b) Fuel Flow - Rolls Royce RB-109	109
62	(a) Residual Thrust - Allison 550-B1	110
	(b) Fuel Flow - Allison 550-B1	111
63	Ducted Fan Performance - Static Sea Level Standard	112
64	Outboard Duct - Allison 550-B1 - D181-960-009	113
65	Inboard Duct - Allison 550-B1 - D181-960-009	114
66	Outboard Duct - Rolls Royce RB-109 - D181-960-007.	115
67	Inboard Duct - Rolls Royce RB-109 - D181-960-007	116

LIST OF FIGURES (Cont'd)

<u>Figure No.</u>	<u>Title</u>	<u>Page</u>
68	In Flight Ducted Propeller Performance	117
69	Drag Coefficient - D181-960-009.	118
70	Lift Curve Slope - D181-960-007 and -009	119
71	(a) Shroud Drag Coefficient - Static Inlet Shroud.	120
	(b) Shroud Drag Coefficient - High Speed Shroud.	120
72	Shroud Drag - S.L. Std. Condition	121
73	Thrust and Drag - D181-960-009	122
74	Thrust and Drag - D181-960-007	123
75	Classical Performance - D181-960-009	124
76	Classical Performance - D181-960-007	125
77	Ferry Range vs. Cruise Altitude - D181-960-007 and -009.	126
78	Ferry Range vs. Speed at 30,000 ft. Altitude D181-960-007 and -009	127

LIST OF TABLES

<u>Table</u>	<u>Title</u>	<u>Page</u>
I	Mission Radii - D181-960-009.....	18
II	Study Configuration Data	55
III	Physical Characteristics..... Configuration D181-960-007 and -009	89-91
IV	Radius Comparison of D181-960-007 and -009.....	100

SUMMARY AND CONCLUSIONS

A performance analysis of ducted propeller assault transport aircraft capable of vertical take-off and landing was made as part of the Navy Contract No. Nonr-1675(00). The work was not required to comply with detailed specifications, but the intent of MIL-C-5011A was followed where particular requirements for this study were not written. A parametric study was made to determine the design regime for specific configurations. Two configurations which were similar except for the size and power loading of the ducted propellers were analyzed in detail and compared. One was powered by six Allison 550-B1 and the other by six Rolls Royce RB109 gas turbine engines. They were designated D181-960-009 and -007 respectively. An analysis of vertical take-off was made to establish useable and optimum thrust to weight ratios and to define the performance of the particular aircraft. Analysis of the short take-off capability of these airplanes, and the resulting increased performance, was also made. The configuration powered by the Allison 550-B1 gas turbine engines (D181-960-009) had the smaller ducts and higher propeller power loadings and was the most promising for development as a VTOL Assault transport.

Best Configuration D181-960-009

The performance analysis of the selected configuration, D181-960-009, indicated a high speed potential of between 460 and 527 mph. It was powered by six Allison 550-B1 engines operating in four ducted propeller units. The engines were mounted integrally with the ducts to take advantage of the residual thrust in vertical flight. The propellers used were chosen as part of the

propeller design study of Reference 1 and do not necessarily represent the best detail design choice. The propellers in the wing tip ducts, which housed two engines each, were contra-rotating, 10 bladed, variable pitch. The inboard ducts housed one engine each and had single rotation 12 bladed variable pitch propellers. The thrust of these units was determined from the momentum analysis which is detailed in Reference 1. Three different detail design studies were completed for the propellers to show arrangements providing this momentum analysis thrust.

The drag analysis of this airplane was made with special emphasis on the drag of the duct units. A comparison between the drag of a high speed and a static inlet duct was made. The drag of the static inlet duct was found to be about 6 1/2 times that of a high speed duct. In order to avoid the drag penalty associated with the static inlet, this analysis clearly pointed to the need for variable geometry flaps on a high speed inlet to achieve the take-off configuration. The drag of the high speed inlet was appreciable but tolerable for the flight range.

The airplane had a sea level rate of climb of 10,700 feet per minute at a gross weight of 60,000 pounds. A time to climb to 30,000 feet of 3.6 minutes, and a service ceiling of 51,100 feet. The classical performance at this gross weight is shown in Figure 1. The ability of this airplane to perform under emergency conditions induced by loss of power was also examined. The airplane was capable of flying to an altitude of 20,000 feet with four of the six engines out. This is equivalent to having only the two inboard ducts or one wing tip duct operating. The rudder was fully capable of trimming the airplane under latter condition. An investigation of loss of power

CONFIDENTIAL
BELL *Aircraft* CORPORATION

in hovering and transition flight was also made. Loss of one engine during hovering would result in a total loss of $1/3$ of the thrust since failure of an engine would require automatic shut down of the symmetrically opposite engine. A descent from 50 feet with $2/3$ thrust would reduce the impact velocity to 21.5 mph. Control would be maintained throughout the descent due to the thrust symmetry. If an engine was lost in level flight a landing could be made at the lowest equilibrium flight speed. This speed was 34.5 mph at a gross weight of 70,000 pounds under sea level standard conditions.

The airplane could accomplish the assault transport mission with a gross weight of 67,380 pounds. The maximum vertical take-off gross weight at 6000 feet and 95°F while maintaining a 3% thrust margin, was 70,000 pounds. At this gross weight the airplane was capable of performing missions with radii and pay loads in excess of the basic requirement. The basic mission requirement with an initial vertical take-off at 6000 feet and 95°F, was for a radius of 425 miles at 300 mph. Twenty percent of the distance was to be flown at sea level. The pay load was to be 8000 pounds out and 4000 pounds back with a vertical landing and take-off at the radius point and no fuel addition. A 10% fuel reserve was held. The basic mission could be accomplished from the take-off gross weight of 67,380 pounds with an average cruise altitude of 27,000 feet. Various extensions and modifications were possible by utilizing the vertical take-off capability at 70,000 pounds. The complete basic mission could be accomplished at a minimum cruise altitude as low as 11,300 feet. Maintaining the cruise altitude of 27,000 feet for the 80% segment, the radius could be increased to 513 miles. If both radius and altitude were maintained for the 70,000 pound take-off, the pay

CONFIDENTIAL
BELL *Aircraft* CORPORATION

load increased to 10,500 pounds. The speed at altitude could be increased to 420 mph still maintaining 300 mph at sea level to carry the 8000 pound pay load 425 miles. The highest speed mission investigated involved a cruise speed of 455 mph at altitude and sea level. This represents a 50% increase in speed. At this high speed the airplane was still capable of a 302 mile radius which is actually a very useful operational distance. If the take-off ambient temperature and altitude were assumed to be standard conditions at sea level, the operational VTOL radius of the airplane was increased by 66% to 705 miles. A VTOL take-off gross weight of 75,800 pounds was possible with these conditions.

This airplane combines the best features of an STOL airplane with its normal VTOL characteristics. If a short runway is available, this aircraft can take advantage of the runway to execute a rolling take-off with an overload of fuel or pay load and tremendously increase its potential. Calculations were made to determine the take-off distance under overload conditions of thrust less than the weight. To perform the rolling take-off, the ducts are rotated to some pre-determined position between the horizontal and vertical. For a thrust weight ratio of .88, which is a gross weight of 82,000 pounds, the angle for minimum ground roll was 50° from the horizontal and resulted in a ground roll distance of 584 feet. With the duct in this position, the airplane is accelerated to lift off speed. After lift off, the climb to 50 feet is made without further rotation of the thrust. When 50 feet is reached, the thrust is rotated to the horizontal as the airplane accelerates to level flight speed.

CONFIDENTIAL
BELL *Aircraft* CORPORATION

Several alternate mission profiles, which used an initial short running take-off, with vertical landings and take-offs at all other points were investigated. The overload was limited to that which would allow a vertical landing at 6000 feet and 95°F at the advanced base. Under these conditions the 425 mile radius with the basic 8000 pound pay load could be increased 2.3 times to 987 miles by overloading to a gross weight of 86,150 pounds. This overload required a take-off ground roll of 770 feet. In the event a radius of 425 miles was adequate, an increase in pay load on the outbound leg from 8000 pounds to 16,720 pounds could be made. This increased the take-off gross weight to 76,890 pounds and required a 300 foot take-off ground roll. A high speed mission showed that a radius of 607 miles was possible with a 450 mph cruise velocity. The take-off gross weight was 83,530 pounds and required a 660 foot ground roll. A graphic presentation of the basic mission, the VTO mission with sea level take-off and the maximum radius STO mission is made in Figure 2. On these missions the heavy weight, vertical landings were made at a weight of 70,000 pounds, which allows a 3% thrust margin at 6000 feet and 95°F. These missions define specific points of the airplanes radius potential and indicate some of the versatility of the vertical take-off transport designed with a short take-off capability.

The ferry range with an 8000 pound payload was investigated with initial vertical take-off and with 400 foot and 800 feet ground roll take-offs. With a vertical take-off at 6000 feet and 95°F at a gross weight of 70,000 pounds the ferry range was 1360 miles. With a 400 foot ground roll, the range was 1850 miles for a take-off gross weight of 78,460 pounds. The range with an 800 foot ground roll was 2520 miles at a gross weight of 86,760 pounds. These ranges were accomplished at 30,000 feet at a cruise velocity of 320 mph.

Configuration D181-960-007

The second configuration (D181-960-007) which was powered by six Rolls Royce RB 109 engines also had a good potential. This configuration was designed with a lower power loading, and consequently with larger propellers than was the -009. The lower power level and higher static thrust to horsepower of this configuration resulted in a lower performance potential. The configuration was designed to see if any advantages in operating economy could be obtained by sacrificing some of the performance potential. The high speed was 390 mph. At a gross weight of 60,000 pounds the airplane had a sea level rate of climb of 7450 feet per minute, a time to climb to 20,000 feet of 3.5 minutes and to 30,000 feet of 6.5 minutes. The service ceiling was 42,000 feet. The mission analysis showed that this airplane could complete the basic mission at a take-off gross weight of 70,000 pounds. The airplane used less fuel than the high performance configuration -009 but had a higher basic mission gross weight due to the larger duct sizes required to produce the same thrust with less power. The ability of this airplane with an initial short take-off was also investigated. With a take-off gross weight of 82,690 pounds and an initial take-off run of 610 feet, the airplane could accomplish a radius of 831 miles. For a 425 mile radius it could carry a payload of 14,200 pounds with a take-off gross weight of 76,530 pounds and an initial ground run of 280 feet.

The ferry range with vertical take-off, and with a 400 foot and an 800 foot running take-off, was determined. The range with a vertical take-off at a gross weight of 70,000 pounds was 1115 miles; with a 400 foot ground run the range was 1605 miles at a gross weight of 78,460 pounds. A range of

2230 miles was possible after an 800 foot take-off at a gross weight of 86,760 pounds. The cruise was at 315 mph at 30,000 feet. Although this configuration had better economy in cruise, the increase in weight due to the larger duct sizes offset this advantage and made the -009 a superior configuration.

Parametric Study, Configuration D181-960-001

The preceding designs were based on a parametric analysis which was made to determine a range of aspect ratio and wing loading for design of ducted propeller, VTOL, assault transport aircraft. The configuration used was characterized by ducts mounted at the wing tips and by booms housing the engines and supporting the empennage. The wing and booms were mounted high on a pod-like fuselage. The power from two Wright T49 engines was shafted through the wing to ducted propellers. In the analysis the aspect ratio was varied from 4 to 10 and the wing loading from 30 to 60 pounds per square foot. The basic assault transport mission was used to evaluate the results of this study. In addition, a general analysis of vertical take-off was made for this configuration.

The aspect ratio variation showed an increased performance advantage with increased aspect ratio; that is the fuel to perform the basic mission decreased, the ceilings increased, and the rates of climb increased. In addition, the wing weight increased. When fuel saving is offset by an increase in wing weight, a region of minimum weight results which extends from about aspect ratio 5 to 7. The other advantages of high aspect ratio led to a choice of the range of aspect ratio between 6 and 7.

The results of the wing loading variation study showed that with constant weight or variable wing area, the minimum weight of fuel plus wing occurred at a wing loading of 53 pounds per square foot. With constant wing area the fuel to complete the mission decreased as the wing loading or gross weight decreased. These effects combine to make the best wing loading slightly lower than that indicated from wing area variation alone, and led to the choice of a range of wing loading from 40 to 60 pounds per square foot. Since the wing weight per unit area will vary from one design to another, the weight cannot be tied into a parametric study with great accuracy. The results of the study led to a range of variables rather than to specific values. The range of aspect ratio from 6 to 7 and of wing loading from 40 to 60 pounds per square foot was incorporated into the later designs.

Vertical Take-Off and Landing

An analysis of vertical take-off capability as a function of thrust to weight ratio was accomplished. The vertical take-off flight path was considered to consist of the following: A vertical rise to hovering at 50 feet, during which the vertical velocity was limited to five feet per second. From hovering at 50 feet, the thrust was rotated intermittently to accelerate the airplane horizontally at low angle of attack and constant altitude to speeds for conventional level flight. Calculations of the total fuel required by the study configuration to complete the vertical take-off and transition to level flight as a function of initial thrust to weight ratio were made. The time to rise vertically to 50 feet as a function of thrust to weight ratio was also determined. The time to rise decreases rapidly with increasing thrust

so that for a thrust increment of 3% the time to rise was reduced from 51 to 13.5 seconds. At the same time, the fuel required for the take-off decreased. If this thrust increment was achieved by a reduction in weight, this would mean a loss of 1500 pounds with an available thrust of 50,000 pounds. If all this weight was fuel, the utilization of a 3% thrust margin would result in a net fuel reduction of 1300 pounds by the time the plane was airborne. This example demonstrates that the most fuel, or pay load, can be taken aloft from an initial thrust weight ratio of one. Also affecting the choice of initial thrust to weight ratio, is the time required to accelerate vertically to five feet per second and the altitude attained at the end of the acceleration. With thrust initially equal to the weight, five feet per second is not attained before 50 feet is reached. Using a 3% thrust margin, the rise velocity is reached in five seconds at an altitude of 12 feet. In order to obtain a positive lift off and acceleration in vertical flight, this analysis indicates that a 3% thrust margin at take-off for a ducted propeller VTOL transport is desirable.

Vertical take-off calculations for the -009 showed that the take-off and transition could be accomplished in about 27 seconds. The acceleration distance after the vertical rise to 50 feet was 1500 feet. The effects of a 40 knot wind were found to be beneficial. The steady wind provides an extra margin of both lift and control during the vertical rise. The take-off time was reduced to 19 seconds and the air distance covered during the acceleration was 350 feet. The effects of unsteady winds were found to be controllable while the average wind gives the same benefits as a steady wind.

CONFIDENTIAL
BELL *Aircraft* CORPORATION

The vertical landing flight path consisted of the following: Thrust rotation from horizontal to vertical with idle power in a normal glide. A flare to a horizontal flight path is made at the deceleration altitude (nominally chosen as 50 feet). As the airplane decelerates at constant altitude and angle of attack, the thrust is increased as the lift decreases. Rotation of the thrust about 10° beyond the vertical gives a decelerating component to the thrust and shortens the deceleration time and distance. When hovering is reached, a vertical descent with a maximum vertical velocity of five feet per second is made. The study indicated that with a 3% thrust margin, the five foot per second vertical velocity can be dissipated in about 12 feet. This led to the use of 70,000 pounds as the maximum vertical landing weight for the -007 and -009 configuration. The landing of the -009 at a gross weight of 70,000 pounds took 45 seconds and covered 3120 feet during the deceleration which was accomplished at zero lift. The time to hovering was 33.2 seconds. At a gross weight of 50,000 pounds the total time was 41 seconds and the distance was 2420 feet. The time to hovering was 29.6 seconds.

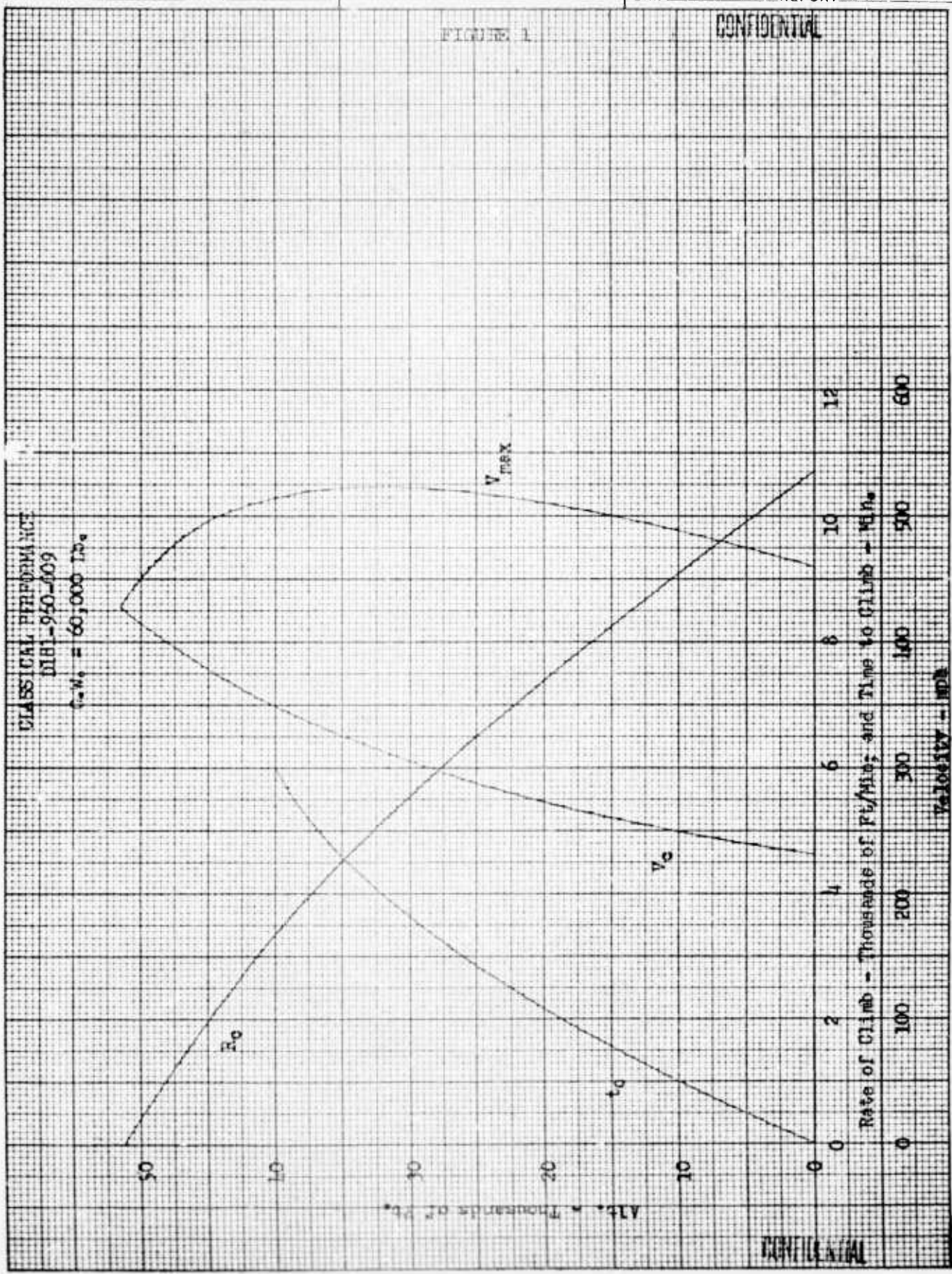

CONFIDENTIAL

FIGURE 2

MISSION RADII

Note: Cruise Vel. = 300 mph
 S.L. Cruise = 20% Total Radius
 D181-960-009

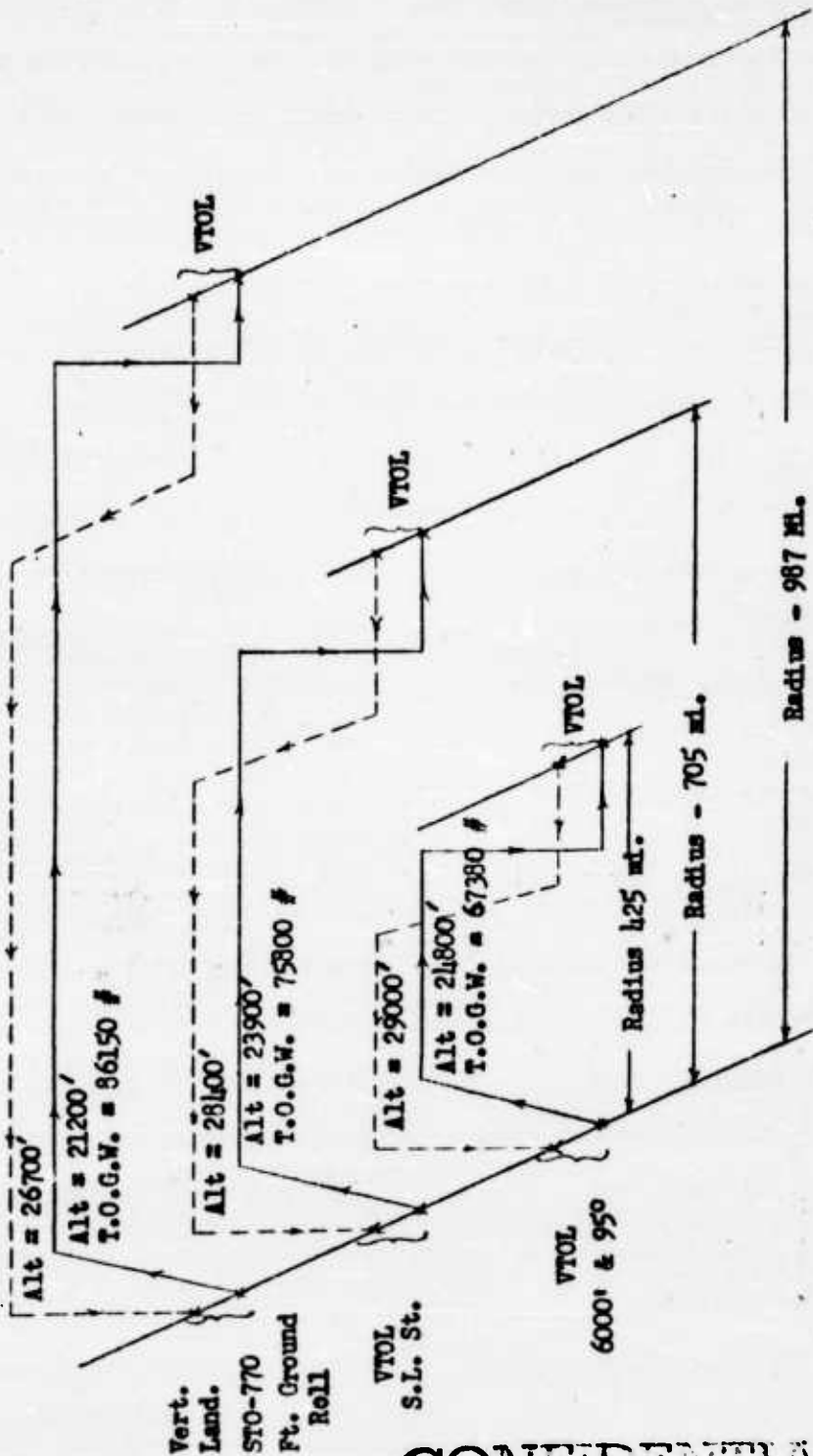

INTRODUCTION

For several years, Bell Aircraft has been engaged in an intensive study of the potential of Vertical Take Off and Landing Aircraft. To augment the detailed studies Bell Aircraft designed and built a light-weight air test vehicle specifically to investigate the performance, stability, control, and operational problems inherent in the low-speed vertical performance. This vehicle has been used to verify the reaction control principle, to evaluate ground heating problems, and has successfully completed a flight test program which covered hovering, transition and level flight under manual pilot control.

During the period preceding the construction of the Air Test Vehicle detailed aerodynamic studies had been completed to evaluate the new and unconventional technical problems presented by such an aircraft. The low speed regime, since it presented the majority of the unconventional problems, was studied first. These studies consisted of detailed examination of the vertical take-off performance, the low-speed stability and control and the development of successful reaction controls.

The application of the ducted propeller propulsion system to the horizontal attitude VTOL was conceived as a link in the level flight speed spectrum between the rotor convertiplane and the jet aircraft. With this concept a study of the feasibility of a vertical take-off and landing assault transport airplane was made under contract with the Office of Naval Research, Nonr-1675(00). This report presents the results of the study which include a parametric analysis to determine the correct design regime and the analysis of specific aircraft. A re-examination of vertical take-off and transition flight was made to determine the influence of the propulsion system.

I. BEST CONFIGURATION HIGHLIGHTS (D181-960-009)

The design represented by the D181-960-009 was selected as the most promising of the configurations investigated. A three view of the airplane is shown in Figure 3. The ducted propellers were powered by six Allison 550-B1 gas turbine engines. These engines were mounted integrally with the four ducted propeller units to eliminate shafting and to take advantage of the residual jet thrust of the turboprop engine in vertical flight. The ducts were mounted at the wing tip and inboard under the wing. The wing tip ducts each carried two engines and the inboard ducts one. The propellers in the wing tip ducts were considered to be contra-rotating, 10 bladed variable pitch while those in the inboard duct were 12 bladed single rotation variable pitch propellers. The inboard ducts had exit stators to remove residual whirl. Exit stators were not required on the wing tip ducts. These types of propellers were designed as part of the propeller design study of Reference 1. They do not necessarily represent the optimum design. There were four detailed solutions to the propeller design problem which could have been used in the ducts. Instead of using a contra-rotating propeller in the outboard duct, a single rotation variable pitch propeller or a single rotation fixed pitch propeller controlled by inlet guide vanes, could have been used. The over-all physical characteristics of the airplane are listed below; a more complete listing is contained in Table III of Section III.A.

Length	81 feet
Height	33 feet
Span	97.7 feet

The airplane was designed to execute a vertical take-off at 6000 feet and 95°F at a gross weight of 70,000 pounds and could accomplish the basic mission at a gross weight of 67,380 pounds. The mission weight permits a 3% thrust margin to provide positive lift off and vertical acceleration at VTOL. The mission required 13,290 pounds of fuel.

I.A. CLASSICAL PERFORMANCE

The classical performance of this configuration is presented in Figure 4. The aerodynamic parameters and thrust and drag curves are presented in Section III.C. The classical performance is presented at gross weights of 50,000, 60,000, 70,000 and 80,000 pounds. The high speed was greater than 400 mph at all altitudes and reached a maximum of 527 mph at 35,000 feet. The sea level rate of climb varied from 12,900 feet per minute at a weight of 50,000 pounds to 7780 feet per minute at 80,000 pounds. The time to climb to 20,000 feet varied from 1.8 minutes to 3.0 minutes over the same weight range. The variation in service ceiling was from 52,600 feet at 50,000 pounds to 47,400 feet at 80,000 pounds. The maximum speed of 527 mph is a theoretical potential based on the momentum analysis thrust. At 460 mph, transonic and supersonic flows begin in the ducts and over the blades. These flows do not preclude operation at higher speeds but do require further study and experimental investigation. A detailed theoretical and experimental investigation of the effect of such flows, which was not possible under this feasibility study, is necessary to determine the details of the design which will make the theoretical high speed attainable in practice.

I.B. DRAG OF THE DUCTS

The study of duct drag resulted in a comparison of the drag of the -009 with both static take-off shrouds and with high speed shrouds. Figure 5 shows the airplane drag and thrust, at sea level, 20,000 and 40,000 feet, with the two shroud configurations. A high speed difference of about 110 mph exists at each altitude. At the speed for minimum drag the use of a static shroud results in an increase in drag of about 50%. A second plot of the shroud drag alone as a function of velocity, is shown in Figure 6. The use of the high speed shroud shows a reduction in the drag of the shrouds by a factor of about 6.5. The use of a take-off flap on a high speed shroud configuration allows for the exploitation of the full potential of the ducted propeller.

I.C. MISSION RADII

The investigation of mission radii for the -009 consisted of evaluating the airplane ability to operate under various conditions of loading, range, altitude, and speed. The basic flight plan of all the radius missions was quite similar to the basic mission. The basic mission required a radius of 425 miles with an initial vertical take-off. An 8000 pound pay load was carried out and 4000 pounds back. This mission was accomplished according to the following general flight plan:

1. Take-off at 6000 feet and 95°F - Vertical or short take-off depending on the initial loading. All of the landings and subsequent take-off were vertical. Pay load out is 8000 pounds or greater.
2. Climb to cruise altitude and fly 80% of the radius.

3. Descend to sea level and fly the remaining 20%.
4. Land vertically at 6000 feet and 95°F. Exchange outgoing pay load for 4000 pound return load. No fuel is added at the radius point.
5. Take-off vertically at 6000 feet and 95°F.
6. Return leg same as outgoing leg. First 20% at sea level, climb to cruise altitude for remaining 80%.
7. Land vertically at 6000 feet and 95°F holding a 10% total fuel reserve.

On all the range and radius calculations the installed fuel flow was increased 5% as specified in MIL-C-5011A. The missions are shown in Table I .

The following missions were calculated according to the above flight plan with variations noted as they occur. The first group of missions had an initial vertical take-off. The airplane was capable of a vertical take-off at a gross weight of 70,000 pounds at 6000 feet and 95°F with a 3% thrust margin. This was considered the maximum vertical take-off weight. For the basic mission the take-off gross weight was 67,380 pounds which included 13,290 pounds of fuel. The average cruise altitude is 26,700 feet at a cruise speed of 300 mph. The total fuel weight of 13,290 pounds also includes the 10% fuel reserve. Using the same take-off gross weight, the radius was increased to 508 miles by elimination of the sea level cruise. This is an increase of 20%. The average cruise velocity was 388 mph at an altitude of 43,350 feet.

CONFIDENTIAL
BELL Aircraft CORPORATION

TABLE I

	TAKE OFF G.W. #	TAKE OFF GROUND ROLL Ft	PAY-LOAD OUT #	RADIUS Mi	CRUISE ALT. OUT Ft	CRUISE ALT. BACK Ft	CRUISE VEL. OUT MPH	CRUISE VEL. BACK MPH	CRUISE VEL. AT S.L. OUT & BACK MPH	TOTAL FUEL #
	STO									
Minimum G.W.	67380	0	8000	425	24800	29000	300	300	300	13290
Minimum Altitude	70000	0	8000	425	11300	11300	300	300	300	15920
Maximum Speed at Alt 300 MPH at Sea Level	70000	0	8000	425	30000	30000	420	420	300	15920
Maximum Radius	70000	0	8000	513	24700	28100	300	300	300	15920
Maximum Radius Initial VTO S.L. Std.	75600	0	8000	705	23900	28400	300	300	300	21720
Radius at Alt. No Sea Level Cruise	67380	0	8000	508	42200	44500	400	376	-	13290
Radius 455 mph speed at all points	70000	0	8000	302	30000	30000	455	455	455	15920
Maximum Payload for 425 mi. radius	76890	300	16720	425	23000	28600	300	300	300	14080
Maximum Radius with 8000 # Payload	86150	770	8000	987	21200	26700	300	300	300	32060
Maximum Radius for 450 mph speed at all points	83530	660	8000	607	30000	30000	450	450	450	29290

NOTE: Alt = 6000 Ft.; T = 95°; Fuel Reserve = 10% total fuel; Payload Back = 4000 #.
 Initial Take-offs are as listed.
 Remaining take-offs and landings are vertical.

MISSION RADII - DI81-960-009

CONFIDENTIAL
BELL *Aircraft* CORPORATION

Various extensions and modifications of the basic mission were possible by utilizing a vertical take-off capability at a 70,000 pound gross weight. By increasing the fuel to a total of 15,920 pounds, the basic mission radius could be increased to 513 miles. Holding the 425 mile radius with a 70,000 pound take-off, the cruise altitude, for the altitude portion, could be reduced to 11,300 feet. Still using the 70,000 pound gross weight the cruise velocity for the altitude portion of the cruise could be increased to 420 mph while maintaining 300 mph at sea level. A shorter but still useful radius of 302 miles was possible with a cruise velocity of 455 mph at altitude and sea level. This high speed mission is a very useful characteristic of the airplane and increases its potential considerably. The combined STO/VTOL characteristics of the airplane were exploited by a group of missions involving short rolling take-off. All landings and subsequent take-offs were vertical. The basic flight plan with 20% of the distance at sea level was followed. The first mission held the 8000 pound pay load and increased the fuel so that the gross weight for the vertical landing at the radius point would be 70,000 pounds. The airplane was capable of a 987 mile radius after a 770 foot take-off run at a gross weight of 86,150 pounds. The basic radius of 425 miles could also be accomplished for maximum pay load of 16,720 pounds after a 300 foot take-off run at an initial gross weight of 76,890 pounds. A high speed mission with cruise at a velocity of 450 mph at all altitudes is also shown in Table I. In this mission a radius of 607 miles was attained with a take-off gross weight of 83,530 pounds using a 660 foot ground roll take-off.

Figures 7 through 9 show the variation of mission radius with altitudes for various hovering times. The mission flight plan consisted of an initial vertical or rolling take-off at 6000 feet and 95°F, a climb to altitude, cruise at altitude, hover at sea level, climb back to altitude, cruise back and land vertically at the initial starting point.

Figure 7 shows the radius for an aircraft using initial vertical take-off at a gross weight of 70,000 pounds. The maximum radius for 15 minutes of hovering time is 500 miles, for 7.5 minutes, 590 miles and for 1.61 minutes 670 miles. All maximum radius points for this gross weight are at 30,000 feet. The 1.61 minute hovering time is equal to the fuel used in a vertical landing and take-off at 6000 feet and 95°F. The radius versus altitude at this hovering time is then equal to radius with a vertical landing and take-off at the radius point.

Figure 8 shows the radius and hovering time for 400 feet ground roll at a gross weight of 78,460 pounds. The maximum radius for this condition for 15 minutes of hovering time is 870 miles, for 7.5 minutes 960 miles, and for 1.61 minutes 1038 miles. All maximum radius points are again at 30,000 feet.

Figure 9 is the variation of radius with altitude for the 800 foot ground roll condition at a gross weight of 86,760 pounds. The maximum radius for 15 minutes of hovering time is 1210 miles, for 7.5 minutes 1308 miles, and for 1.61 minutes 1380 miles. The altitude for these maximums is increased to 40,000 feet. Between sea level and 3000 feet the radius varies almost linearly with altitude with the velocity equal to 300 mph. For all the conditions mentioned, the speed above the altitude of 30,000 feet is greater than 300 mph.

I.D. FERRY RANGE

The one way range capability of the -009 airplane is shown in Figures 10 and 11. The ferry range with an 8000 pound payload was investigated with initial vertical take-off and with 400 foot and 800 foot ground roll take-offs. At the low altitudes the velocity for long range cruise was less than 300 mph while at the higher altitudes it was greater. A minimum cruise velocity of 300 mph was used in these calculations. The range for both configurations increases steadily with increase in altitude, reaching an altitude where the velocity for long range becomes equal to 300 mph. From that point on the range increase with altitude is smaller, and maximum range occurs at a cruise altitude of 40,000 feet.

The ferry range capability as a function of cruise altitude is shown in Figure 10. For the basic mission, gross weight of 67,380 pounds, the maximum ferry range is 1160 miles at the altitude of 40,000 feet. The maximum range increases to 1380 miles at 40,000 feet for a gross weight of 70,000 pounds. For the STO mission, using a 400 foot ground roll at a gross weight of 78,460 pounds, the maximum range increases to 2010 miles. Using an 800 foot ground roll at a gross weight of 86,760 pounds increases the maximum range to 2530 miles. All maximum ranges are at an altitude of 40,000 feet. There is not much change in ferry range between the altitudes of 30,000 feet and 40,000 feet. The velocities in this region for all conditions are greater than 300 mph. Between the altitudes of sea level and 30,000 feet, the range at a constant velocity of 300 mph increases with increasing altitude. This variation is approximately linear.

Figure 11 shows the variation of range with speed at a constant altitude of 30,000 feet. The vertical portions of these curves are a result of the limitation imposed on the speed for long range operation. Specification MIL-C-5011A defines this speed as the greater of the two speeds at which 99% of the maximum miles per pound of fuel is attainable. For a vertical take-off at a gross weight of 67,380 pounds, the maximum range of 1120 miles is attained for velocities ranging from 265 mph to 320 mph. From the above definition, the velocity for long range cruise is 320 mph. For the same speed range but a gross weight of 70,000 pounds, the range increases to 1361 miles. The gross weight increase is mostly due to an increase in the fuel load. Using a 400 foot ground roll at a gross weight of 78,460 pounds, increased the maximum range to 1855 miles for velocities ranging from 276 mph to 311 mph. For an 800 foot ground roll at a gross weight of 86,760 pounds, the maximum range is increased to 2520 miles. The velocity range remained the same as the one for the previous gross weight. A small range decrease results from an increase of speed above that for long range. Due to this fact, the airplane is able to perform special high speed missions with only a small decrease in range potential.

Figure 12 shows the variation of range with hovering time. The flight plan consisted of a vertical take-off at 6000 feet and 95°F, a climb to altitude, cruise at altitude and hover at the final point. The pay load out was 8000 pounds. The mission can be called a "yardstick" mission whereby the hovering potential of the -009 is shown. The extreme ends of the curve give the maximum and minimum hovering times for the

various gross weights. The maximum hovering weight is taken as 70,000 pounds at 6000 feet and 95°F. For a vertical take-off at a gross weight of 70,000 pounds, the maximum hovering time is 73 minutes while the minimum hovering time represents the 10% fuel reserve and is equivalent to seven minutes at a range of 1385 miles. For a 400 foot ground roll at a gross weight of 78,460 pounds, the maximum time is 74 minutes at a range equal to 620 miles. The minimum time is 11.5 minutes with a range of 1970 miles. Using an 800 foot ground roll at a gross weight of 86,760 pounds increases the range for maximum hovering to 1260 miles while the hover time remains at 74 minutes. The minimum time is 15.5 minutes at a range of 2460 miles.

I.E. EMERGENCY OPERATION - LEVEL FLIGHT

The investigation of level flight emergency operation consisted of an evaluation of the ability of the -009 airplane to operate with reduced power. Drag and thrust curves for sea level, 10,000 and 20,000 feet, at a gross weight of 70,000 pounds, are presented in Figures 13, 14 and 15. The drag curves are for all engines operating, 1 - inboard duct inoperative, 2 - inboard ducts inoperative, an inboard and an outboard duct inoperative and both outboard ducts inoperative. This is equivalent to having 6, 5, 4, 3, and 2 engines operating. The drag changes are due to the increase in drag which occurs with the power off in the duct. A series of calculations were made to evaluate the loss of power in the four engines located in the outboard ducts or two engines in one outboard duct and each inboard duct. This assumption requires

the airplane to fly on the remaining two engines represented by the inboard ducts or one outboard duct. The high speed reduction due to loss of power at sea level is from 460 mph with full power to 250 mph. At 10,000 feet, the speed change is from 480 mph to 255 mph and at 20,000 feet the maximum velocity goes from 510 mph to 240 mph. The ability of the airplane to climb under these reduced power conditions at the 70,000 pound gross weight is shown in Figure 16. The sea level rate of climb goes from 9000 feet per minute with full power to 1300 feet per minute with two engines operating. The service ceiling goes from 49,000 feet to 20,000 feet. In general the airplane is capable of operating over a wide range of speeds and altitudes with as few as two engines operating. The rudder is capable of trimming the airplane in level flight with power supplied only from both engines of one outboard duct as is shown in Reference 2 .

I.F. VERTICAL TAKE-OFF AND LANDING

An analysis of the vertical take-off capability of the -009 was accomplished. The vertical take-off flight path was considered to consist of a vertical rise to 50 feet, followed by transition to speeds for conventional level flight. The speed during the vertical ascent was limited to five feet per second. The transition to level flight was made at low angle of attack and constant altitude by intermittent rotation of the thrust. The take-offs were made at an altitude of 6000 feet and 95°F.

Figure 17 shows a time history of the -009 at a gross weight of 70,000 pounds and T/W = 1.03. The vertical rise to 50 feet was accomplished in 12.7 seconds. A velocity of five feet per second was attained

in 4.9 seconds at an altitude of 12 feet. The acceleration to flying speed was accomplished in an additional 15.5 seconds, when a velocity of 236 feet per second was reached. The thrust rotation was accomplished intermittently at a fixed rate of 15° per second. The total time was 28.2 seconds and a distance of 1740 feet was covered during the acceleration.

A time history of the -009 at a gross weight of 70,000 pounds and $T/W = 1.03$, using a vertical take-off in a 40 knot wind is presented in Figure 18. The vertical rise to 50 feet was accomplished in 11.6 seconds. The acceleration to flying speed was accomplished in an additional 7.2 seconds when a velocity of 208 feet per second was reached. The thrust rotation was accomplished intermittently at a fixed rate of 15° per second. The total time was 18.8 seconds and a distance of 350 feet was covered during acceleration.

Figure 19 is a time history of the -009 for a landing with a gross weight of 50,000 pounds. The vertical landing path consisted of the following: thrust rotation from horizontal to vertical with idle power in a normal glide. A flare to a horizontal flight path is made at the deceleration altitude (normally chosen as 50 feet). As the airplane decelerates at constant altitude and angle of attack, the thrust is increased as the lift decreases. Rotation of the thrust about 10° beyond the vertical gives a decelerating component to the thrust and shortens the deceleration time and distance. When hovering is reached, a vertical descent with a maximum vertical velocity of five feet per second is made. The time to decelerate was 29.6 seconds over a range of 2420 feet. The

initial velocity is 218 feet per second. The vertical descent was completed in 12 seconds making the total landing time equal to 41.6 seconds.

Figure 20 is a time history of the -009 for a landing at a gross weight of 70,000 pounds. The flight path is the same as mentioned previously. The time to decelerate was 33.3 seconds over a range of 3180 feet. The total time to complete the landing was 45.2 seconds.

The stall speeds for the -009 at maximum lift coefficient are shown in Figure 21. This curve is of interest in that it shows the speeds for start of landing transition and end of take-off transition as a function of gross weight. In vertical take-off and landing, the stall speed is a reference speed rather than a lift-off or touch-down speed. The speed varies from 124 mph at a gross weight of 50,000 pounds to 166 mph at a 90,000 pound gross weight.

I.G. SHORT TAKE-OFF

Figures 22 through 24 show the result of the short take-off analysis for T/W ratios ranging from .8 to 1.0. The short take-off was made by placing the ducts in an intermediate position, between horizontal and vertical. With the thrust in such a position the vertical component augments the take-off lift coefficient and determines the lift-off speed. The horizontal component accelerates the airplane to this speed. Figure 22 shows the variation of ground roll distance with rotation angle, λ , for thrust weight ratios of .80, .88, and .95. At each T/W the minimum ground roll distance occurs at a different angle, showing that the balance between lift-off speed and acceleration ability varies as the weight varies. These calculations were made considering the thrust available at 6000 feet and 95°F.

From the lift-off point a climb to a 50 foot altitude was made without any thrust rotation. When 50 feet was reached, the airplane was accelerated in a manner similar to the vertical take-off transition, until the ducts were horizontal and the airplane was at normal flying speed. Figure 23 shows the minimum ground roll as a function of thrust and weight ratio. A vertical take-off is possible with thrust equal to weight.

With a thrust weight ratio of .8 a 925 foot ground roll is possible. Take-off distances as a function of gross weight are shown in Figure 24. Shown are the ground roll distance and distance over 50 feet for weight greater than 72,100 pounds. Although a 3% thrust margin was considered desirable for the vertical take-off, a VTO is feasible at a $T/W = 1.0$ which occurs at a weight of 72,100 pounds. The basic mission take-off weight for the -009 and -007 are called out and were 67,380 pounds and 70,000 pounds respectively.

I.H. EMERGENCY OPERATION - HOVERING AND TRANSITION

An analysis of emergency operation during vertical take-off and transition was made which considered the effects of single and multiple engine failure on the -009 configuration. The airplane was designed so that loss of an engine in hovering or low speed flight would result in automatic shutdown of the symmetrically opposite engine.

Engine failure in hovering flight or at transition speeds below those which can be maintained at reduced power, would result in a controlled crash in the hovering attitude. Since the time for transition is roughly 6 to 15 seconds, this critical area of flight is definitely minimized. Figure 25 shows impact velocity as a function of height at which

the power is lost, for the condition of 0, 2, and 4 engines operating. No advantage was taken of the drag during the fall. With four engines operating the impact velocity from 50 feet was 21.5 mph while with no engines operating it was only 38.6 mph. If the initial altitude assumed for failure is reduced, considerable reduction of these speeds is possible. While these speeds would probably inflict damage to the landing gear and airframe, the airplane has been designed such that the structural deformation would provide a cushion to protect the occupants during the deceleration, References 3 and 4. The symmetry of power will permit a wing and fuselage level attitude to be maintained.

A consideration of engine failure during transition to level flight led to the analysis of the ability to maintain equilibrium flight at speeds below the aerodynamic stall speed in order to accomplish a low speed emergency landing. With one engine out at a gross weight of 70,000 pounds this speed was only 34.5 mph. The speed of transition limits this danger zone to a period of less than 10 seconds. Figure 26 shows a plot of the ratio of power required to power required for hovering and the ratio of power available to power required for hovering as a function of velocity. With four engines out the equilibrium speed was still only 84.2 mph. These calculations indicate that the ducted propeller VTOL assault transport will have adequate safety in operation at least comparable with conventional aircraft.

By _____ Date _____
Checked _____ Date _____

BELL Aircraft CORPORATION

Model _____ Page 29
Missile _____
Airplane _____ Report D181-945-004

CONFIDENTIAL

CONFIGURATION - D181-960-009

FIGURE 3

6 Allison 550-B-1
Engines

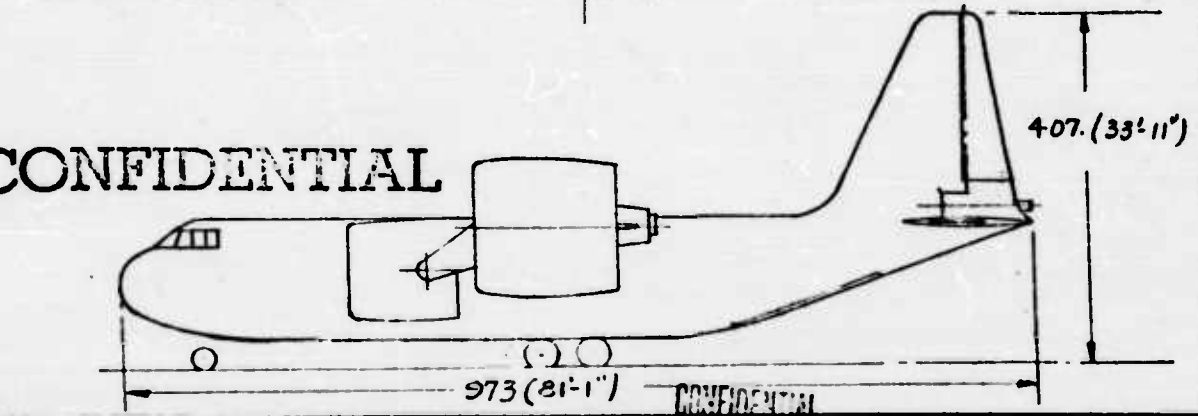
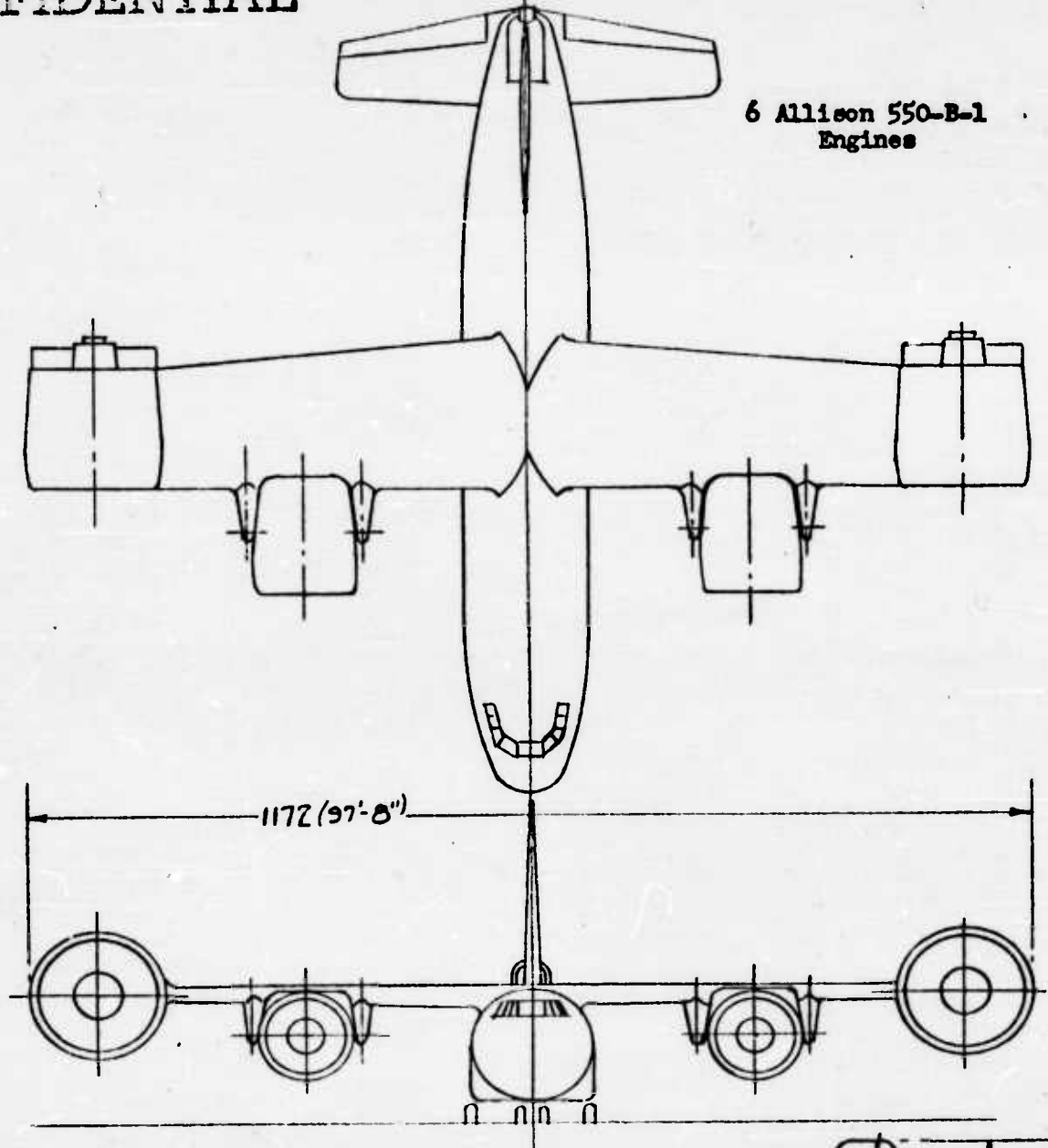

CONFIDENTIAL

Form 84-1 Rev. 2/53

$\frac{1}{200}$
SCALE

CONFIDENTIAL

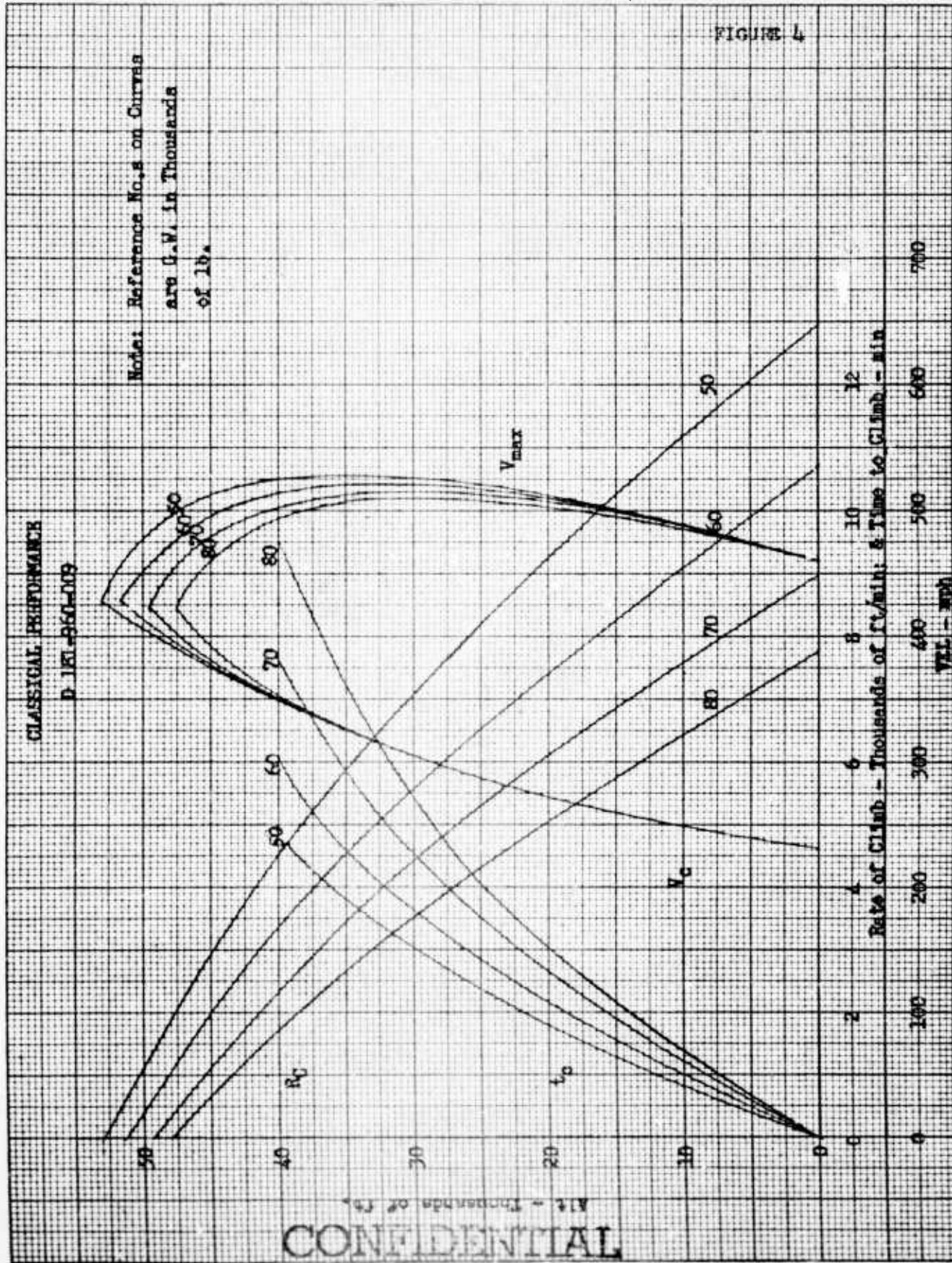

CONFIDENTIAL
 Alt - Thousands of Ft.

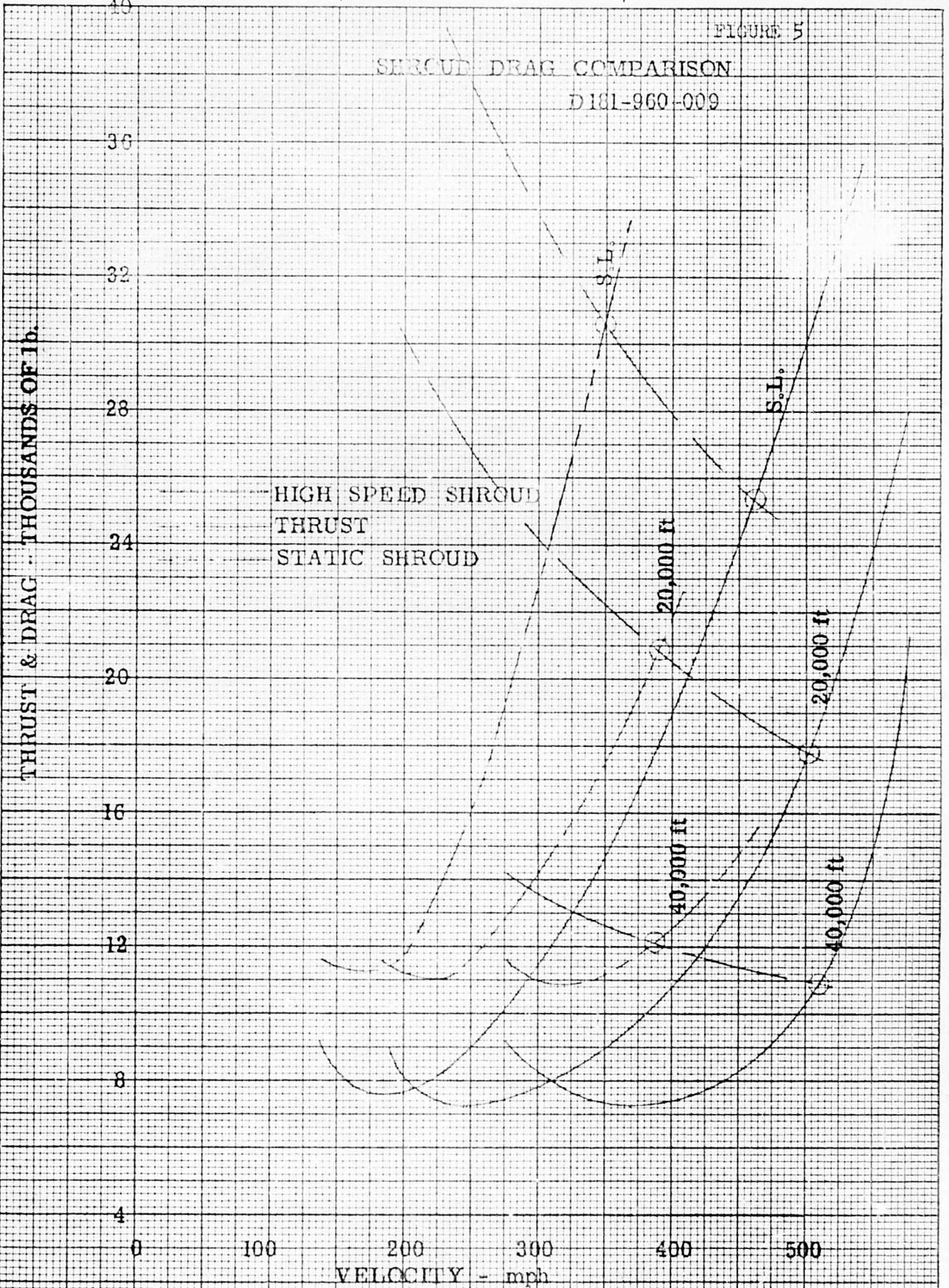

CONFIDENTIAL

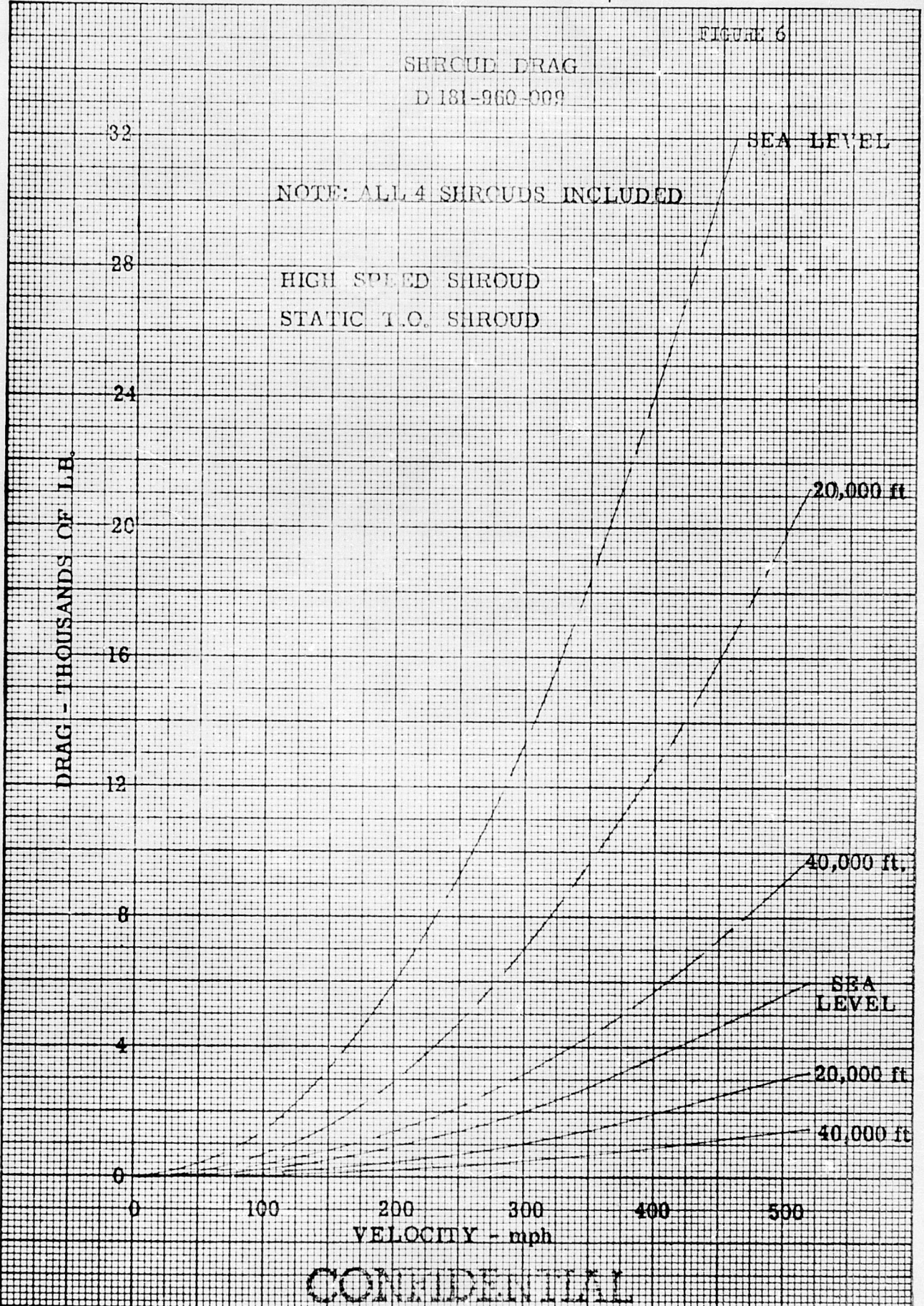
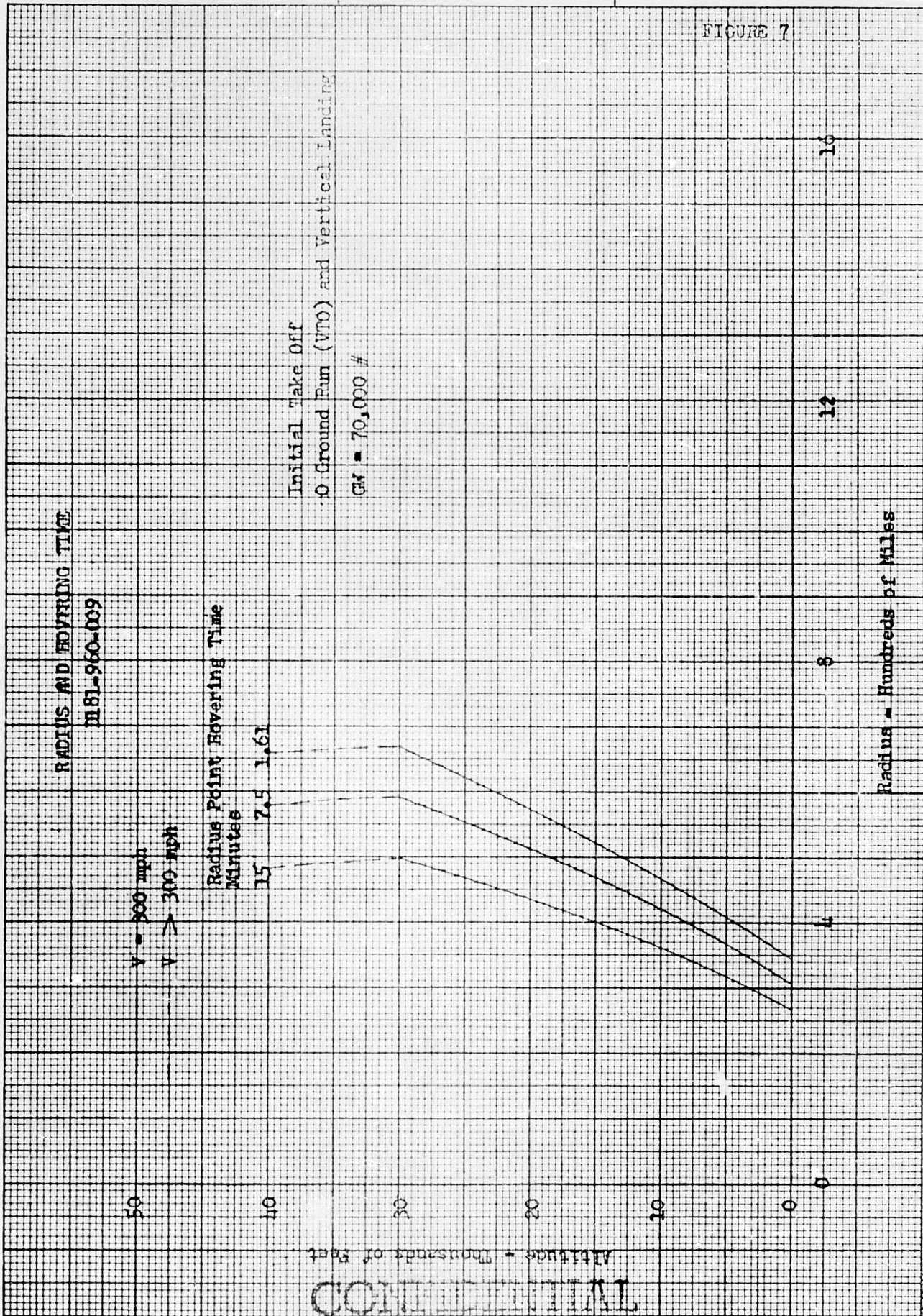
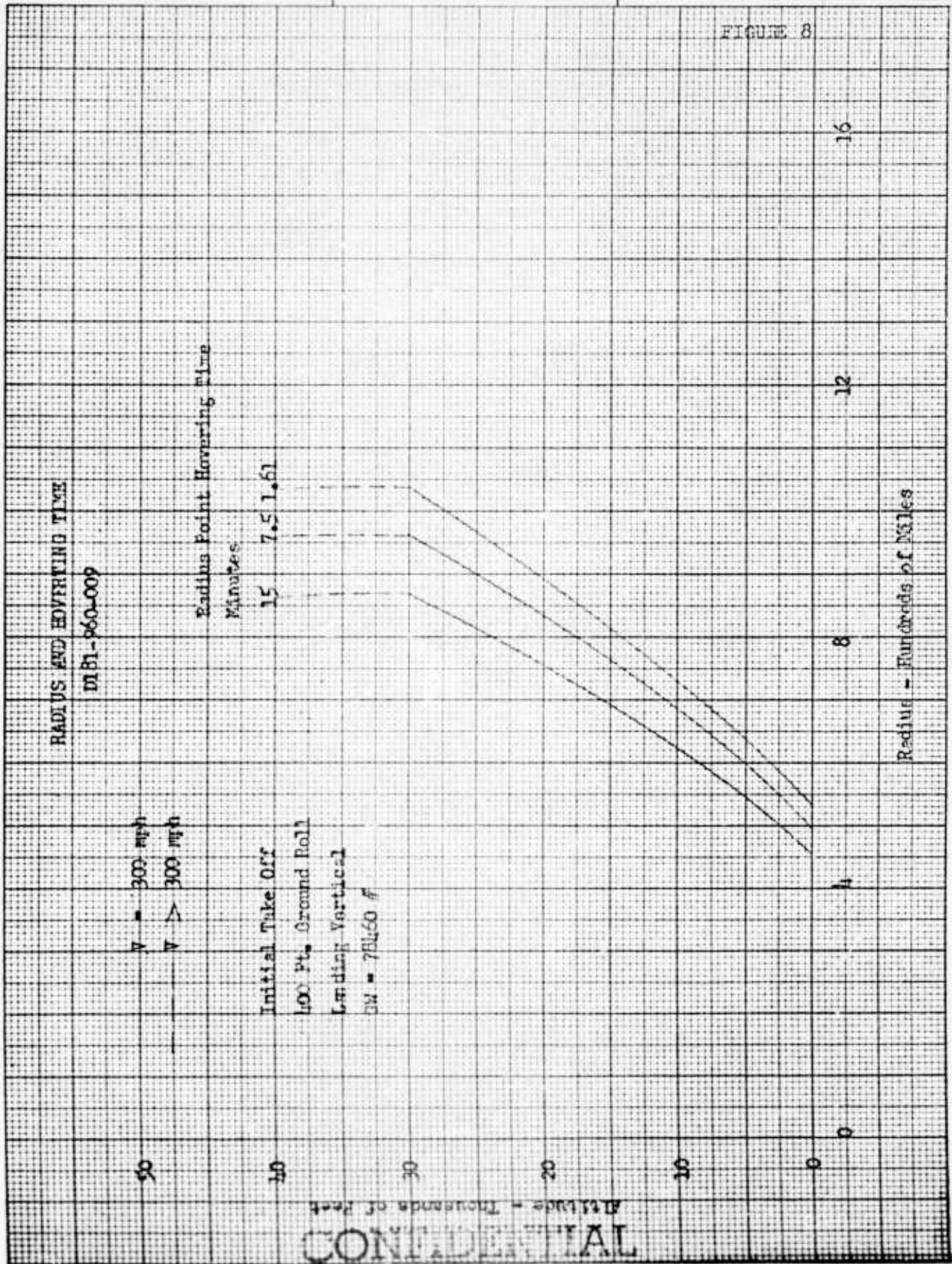

FIGURE 7



CONFIDENTIAL



CONFIDENTIAL

BY _____ DATE _____
CHECKED _____ DATE _____

BELL *Aircraft* CONFIDENTIAL CORPORATION

MODEL _____ PAGE 35
SHIP _____ REPORT D181-945-004

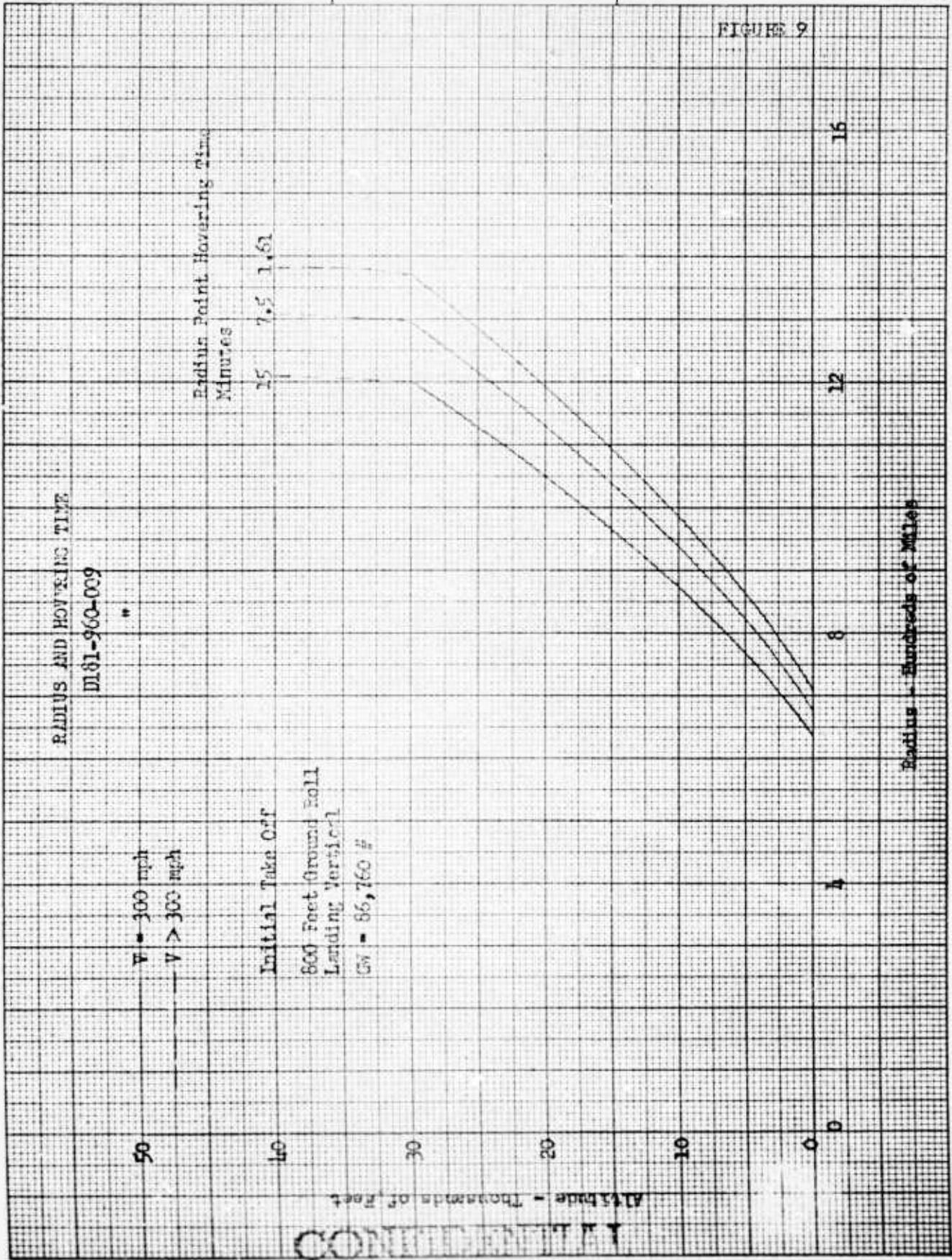

CONFIDENTIAL

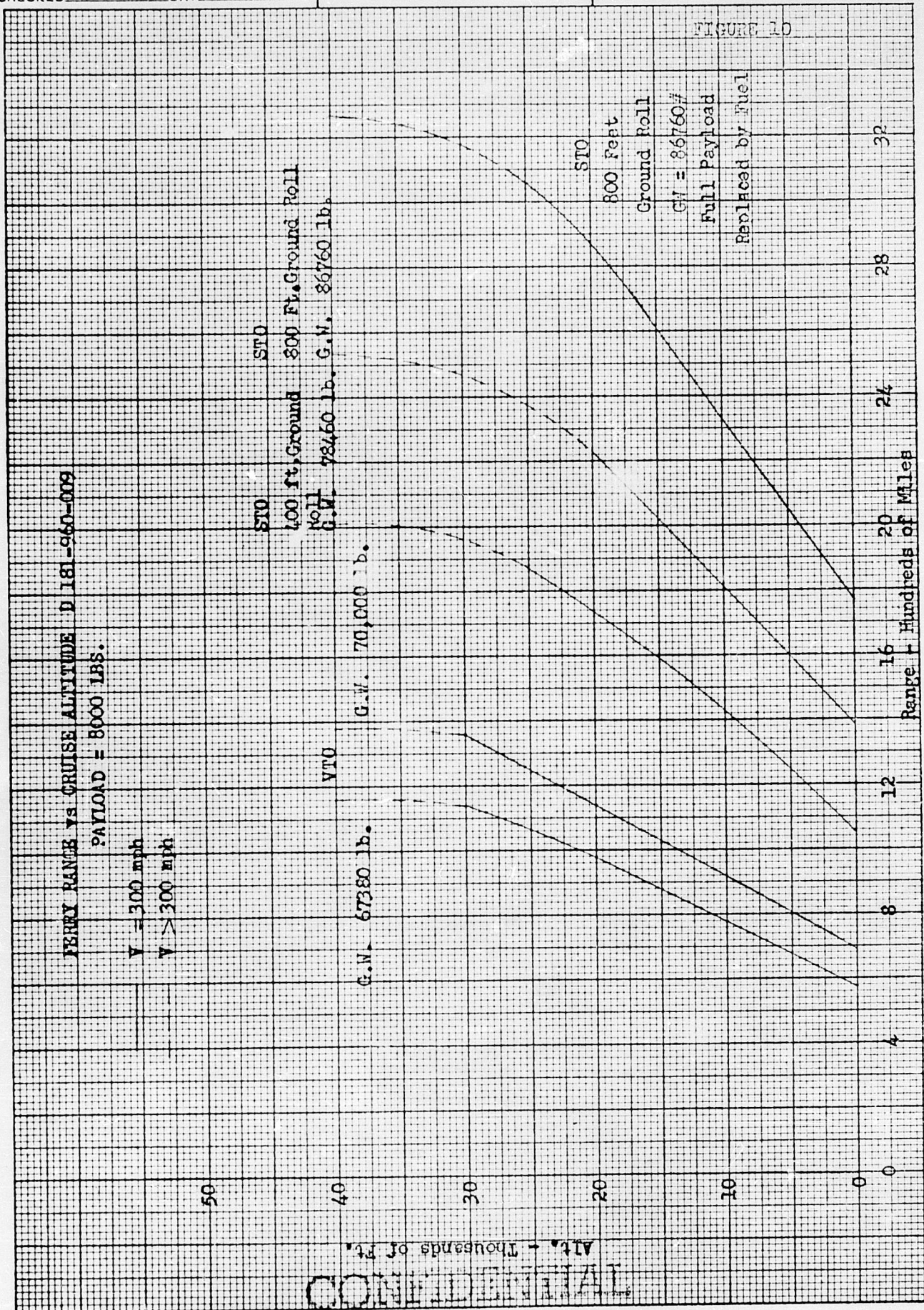

CONFIDENTIAL

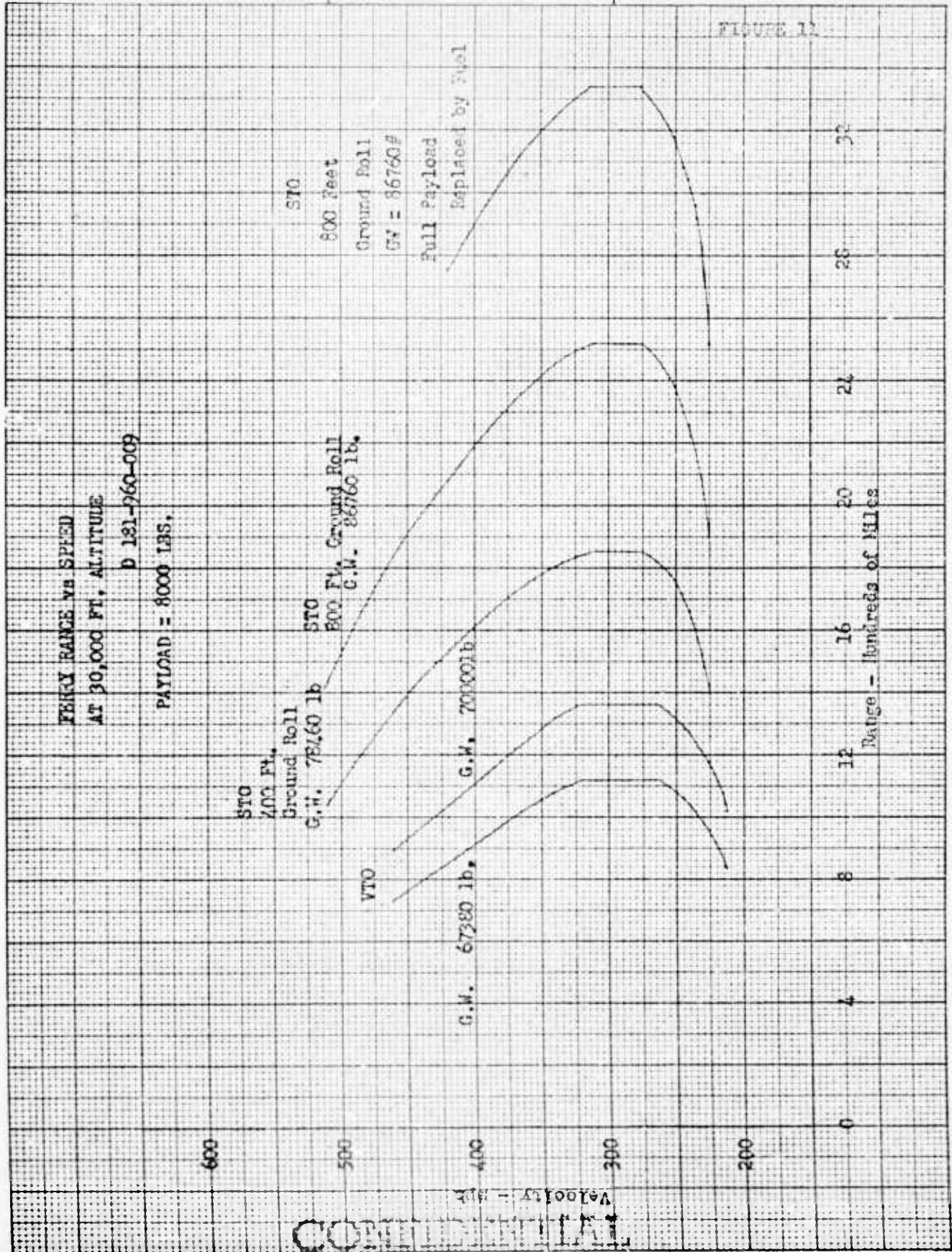
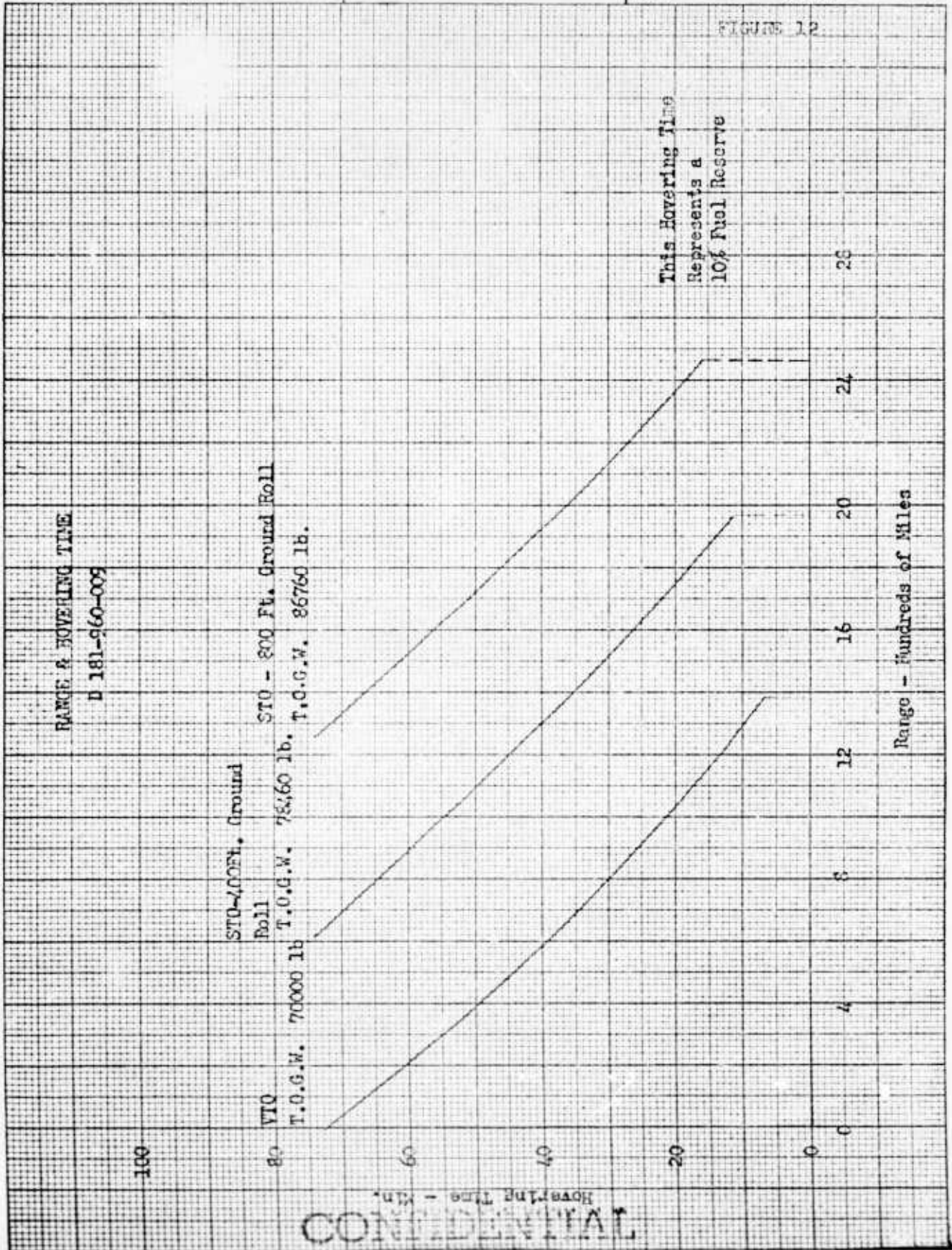

FIGURE 12



CONFIDENTIAL

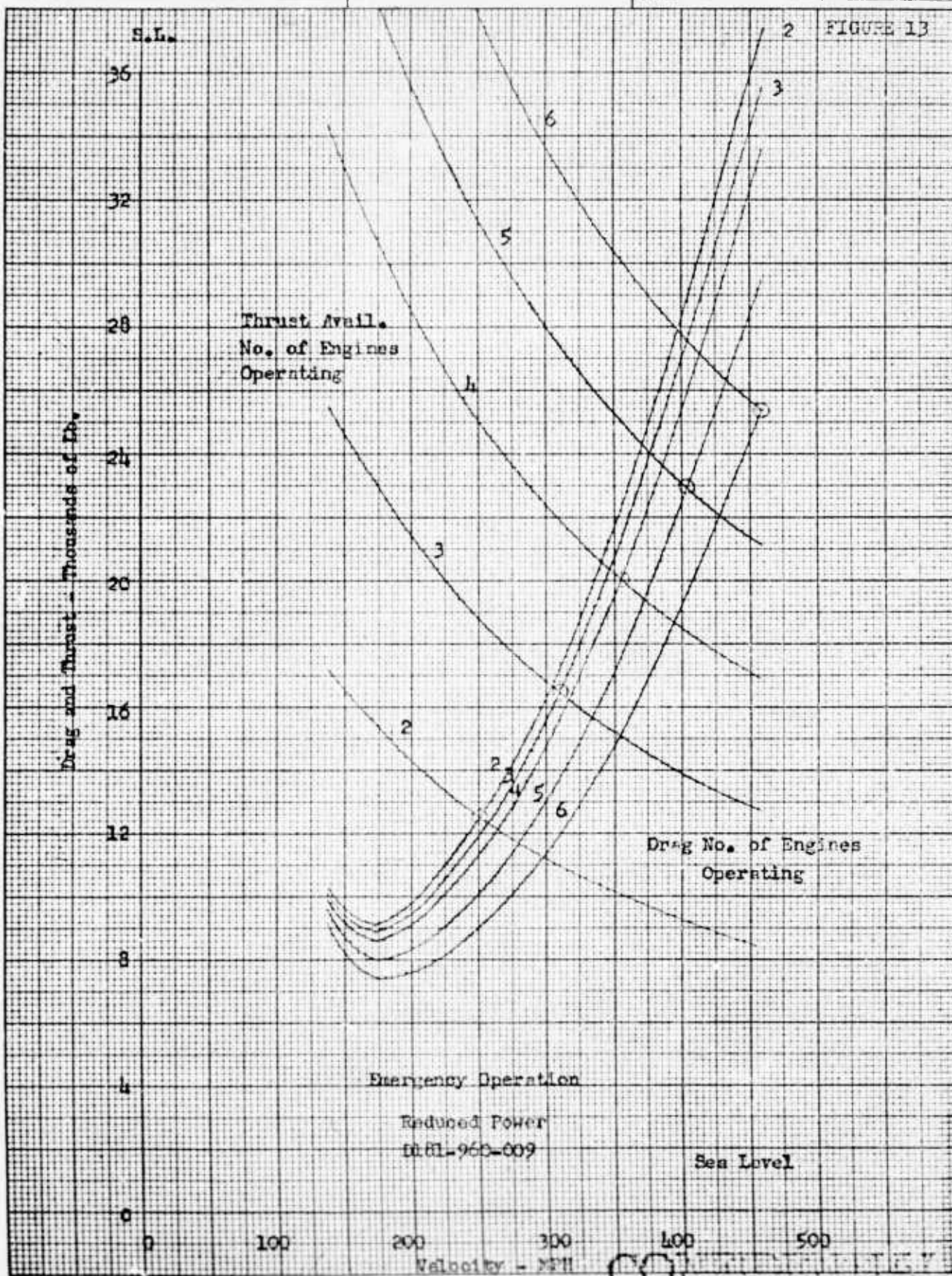

FIGURE 1A

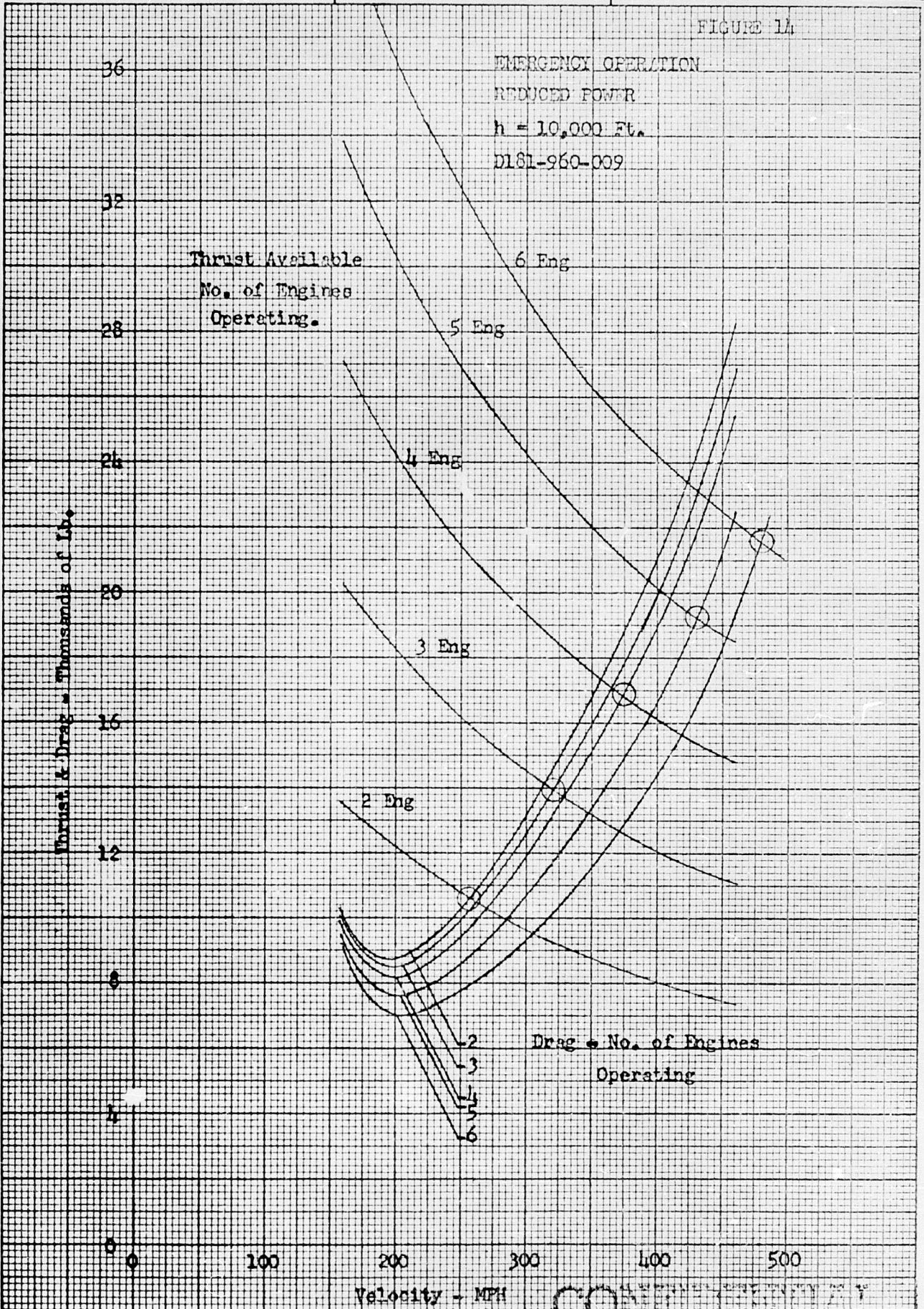
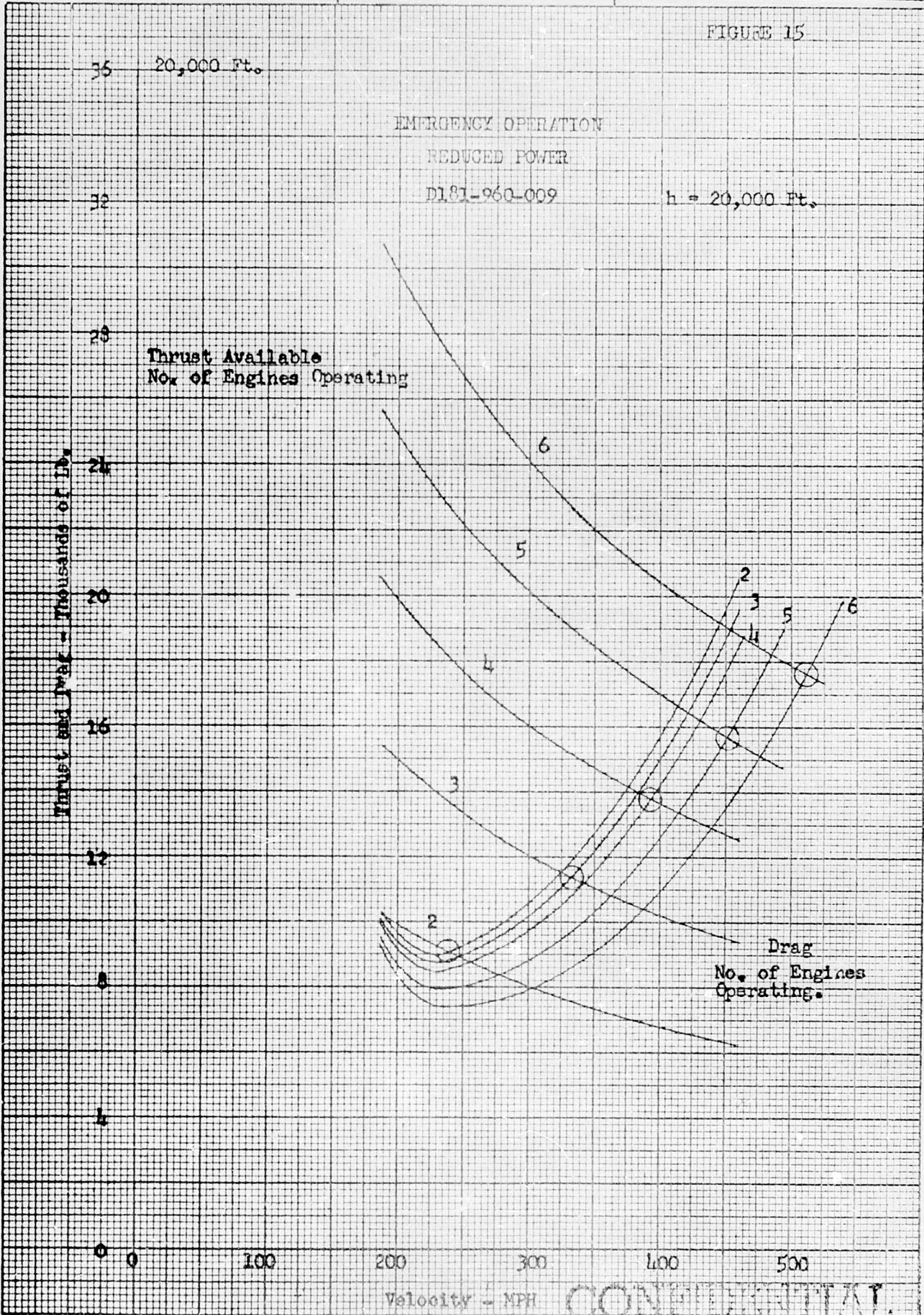

FIGURE 15



BY _____ DATE _____
CHECKED _____ DATE _____

BELL *Aircraft* **CONFIDENTIAL**
CORPORATION

MODEL _____ PAGE 42
SHIP _____ REPORT D181-945-00

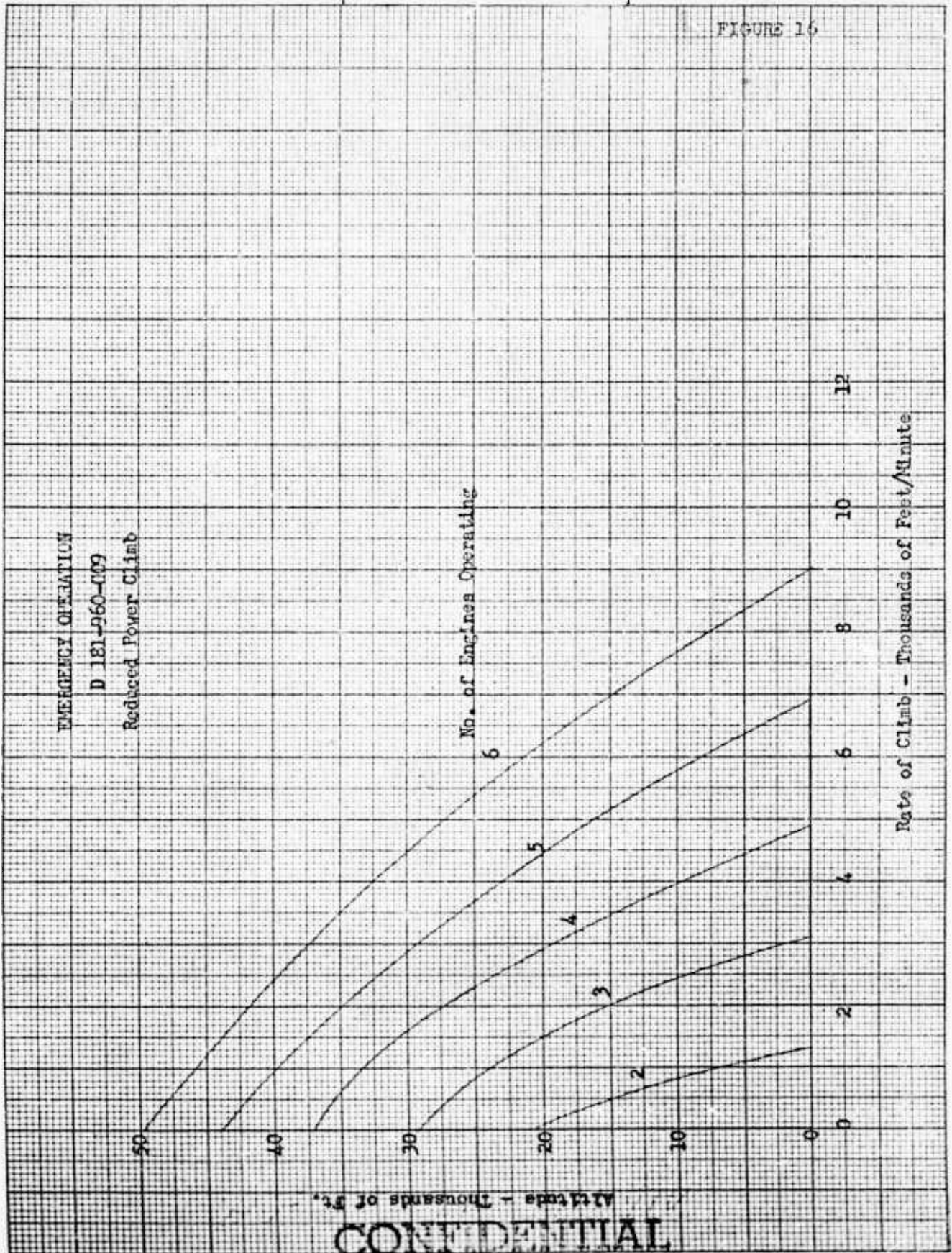

CONFIDENTIAL

FIGURE 17

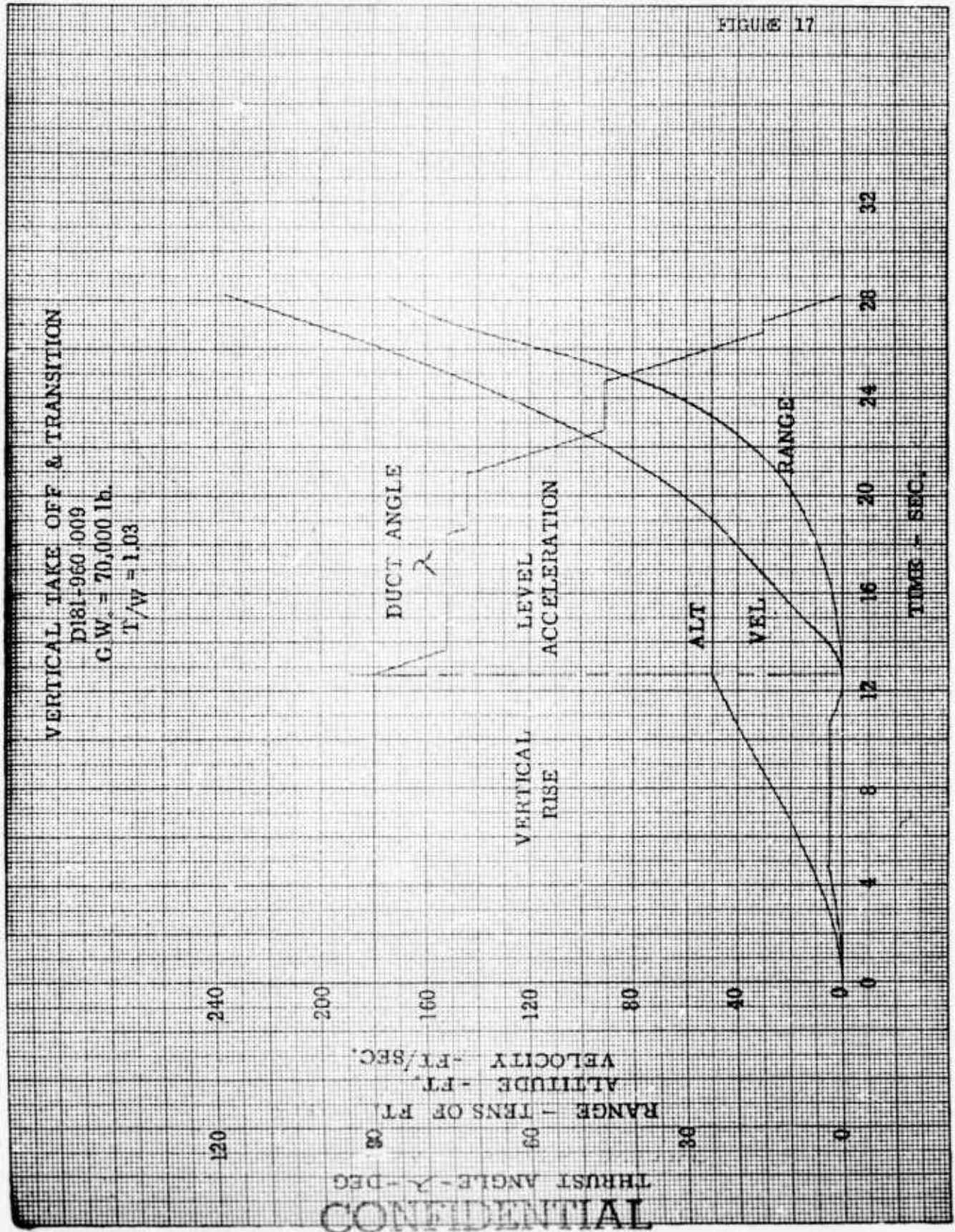

BY _____ DATE _____
 CHECKED _____ DATE _____

BELL *Aircraft* CORPORATION

CONFIDENTIAL

MODEL _____ PAGE 44
 SHIP _____ REPORT D181-945-001

FIGURE 18

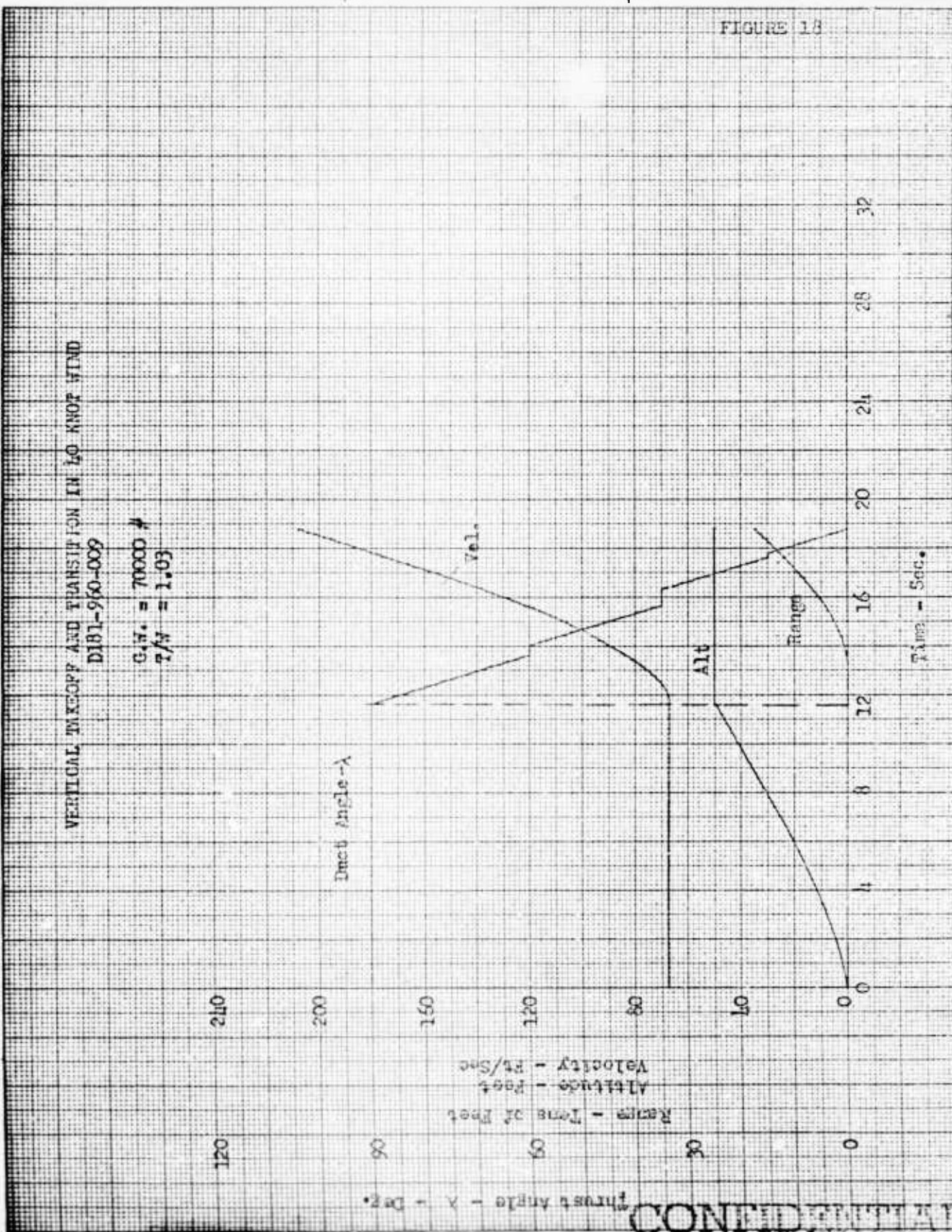

CONFIDENTIAL

FIGURE 19

D181-960-009
 G.W. = 50,000 L.B.
 C_L = 0

LANDING PERFORMANCE

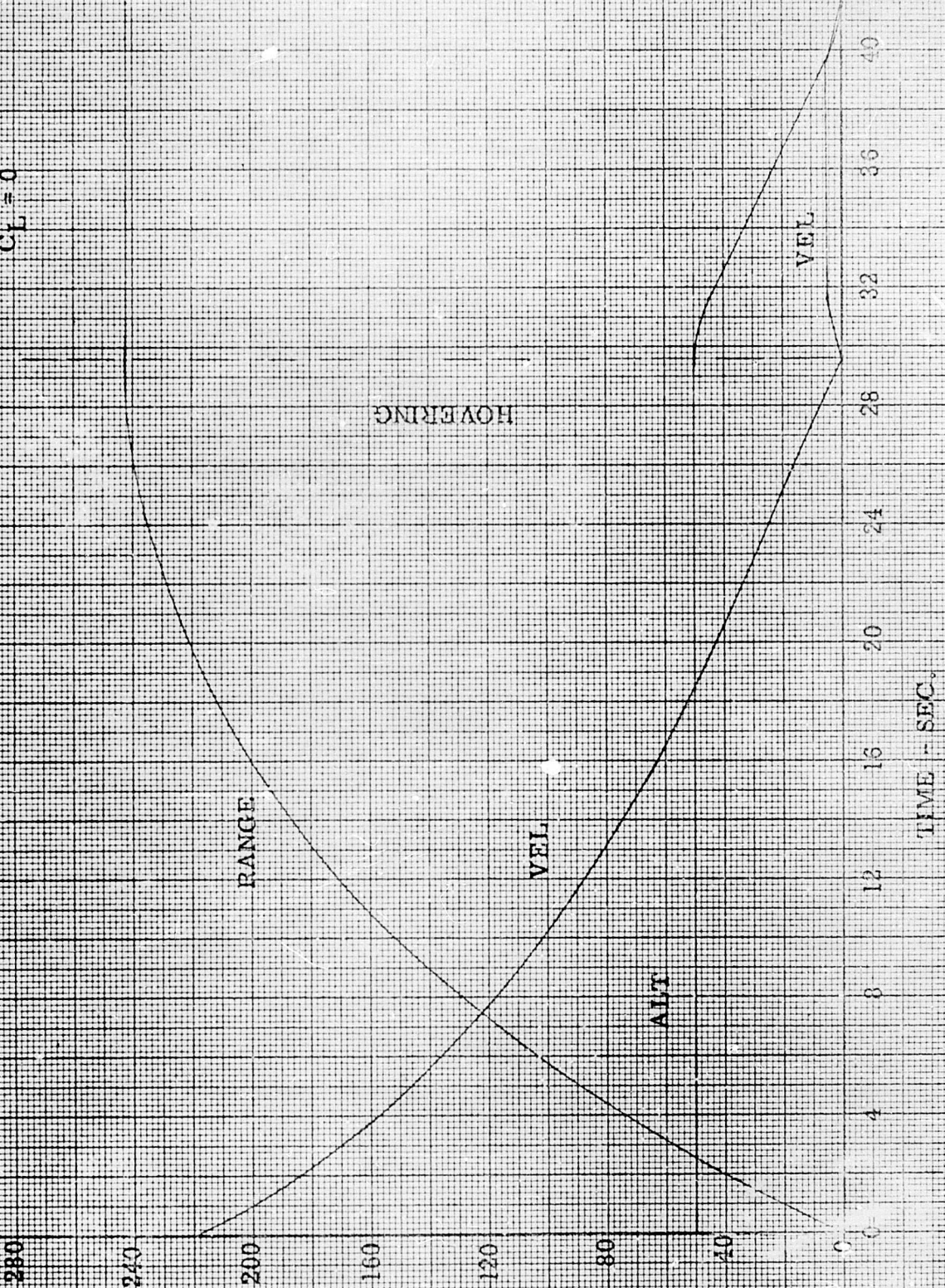

BY _____ DATE _____
 CHECKED _____ DATE _____

BELL Aircraft CORPORATION

MODEL _____ PAGE 46
 SHIP _____ REPORT D181-945-004

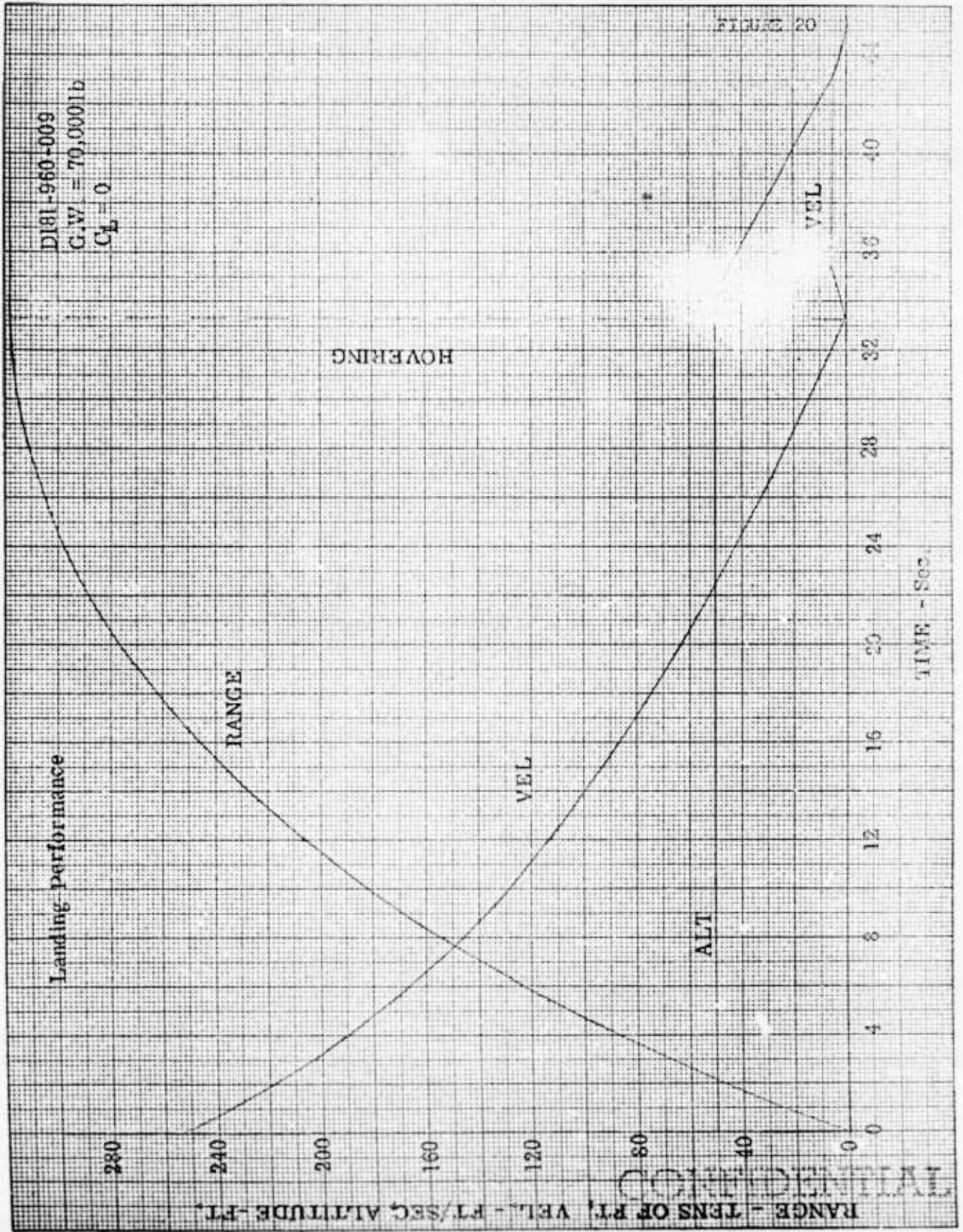
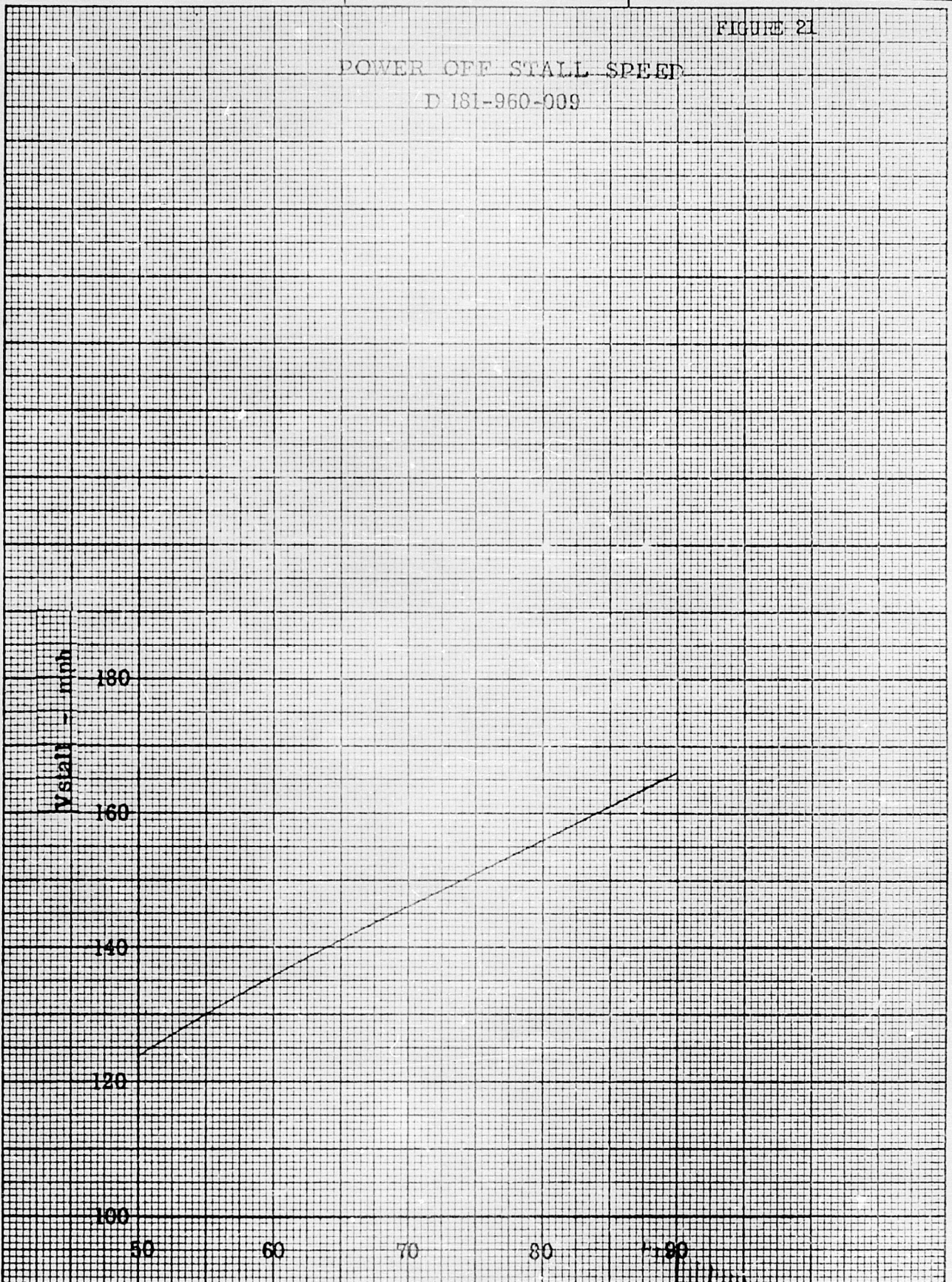

FIGURE 21

POWER OFF STALL SPEED
D 181-960-009



G.W. - THOUSANDS OF LB

FIGURE 22

SHORT TAKE OFF
GROUND ROLL VS. THRUST ANGLE
D181-960-009

h = 6000 Ft.
T = 95° F

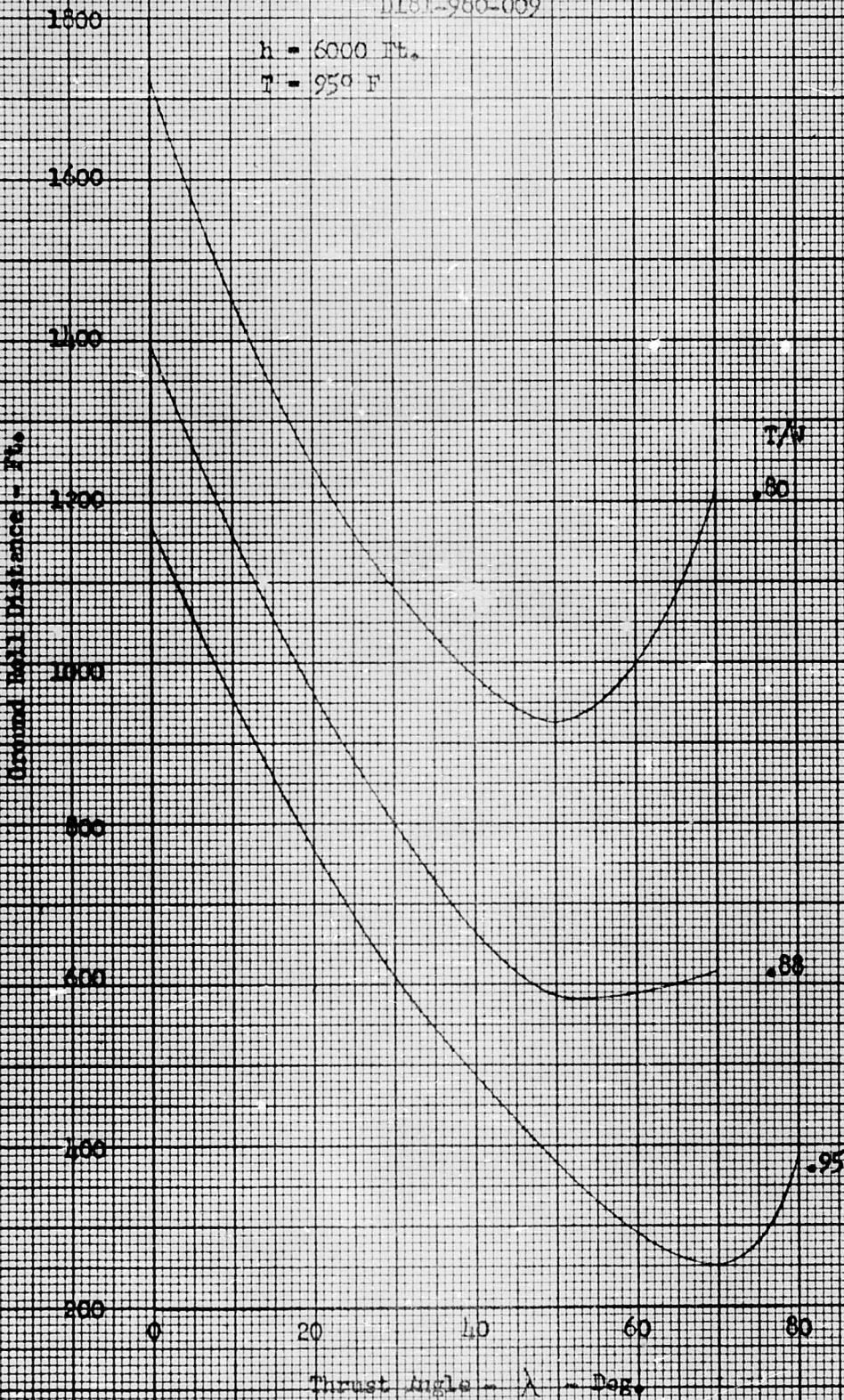
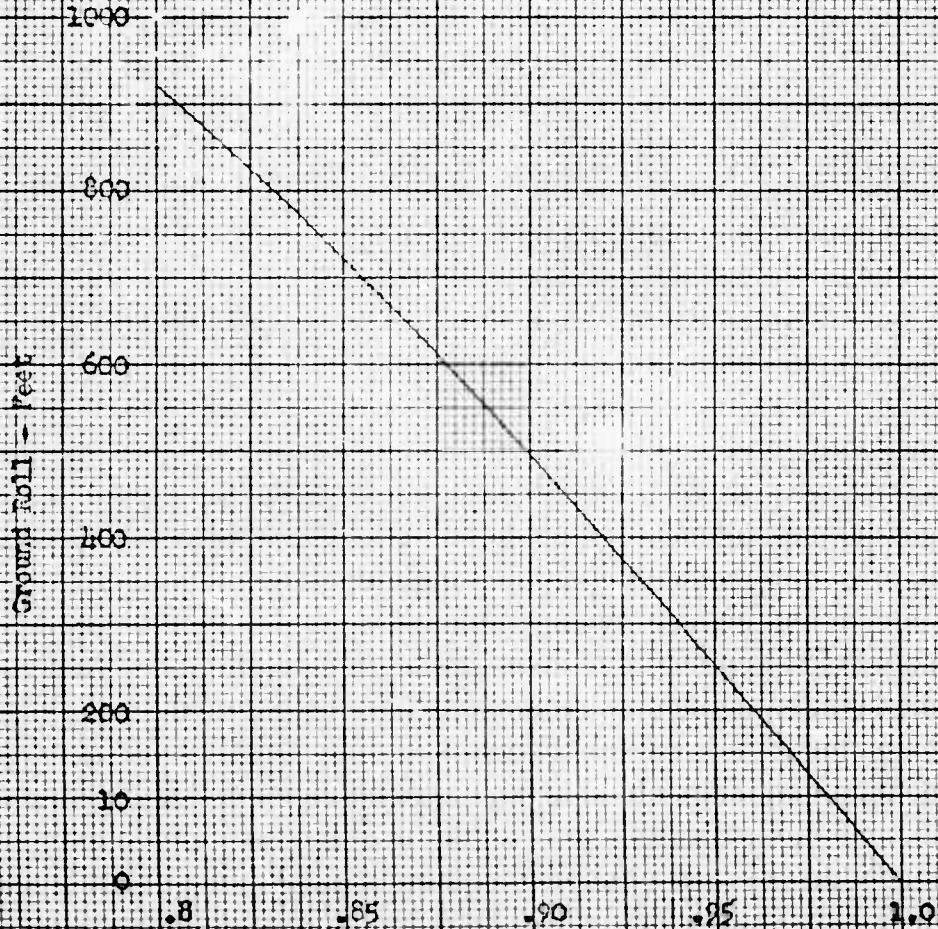

FIGURE 23

GROUND ROLL VS. T/W



T/W

CONFIDENTIAL

BY _____ DATE _____
CHECKED _____ DATE _____

BELL *Aircraft* **CORPORATION**

MODEL _____ PAGE 50
SHIP _____ REPORT DJ81-945-004

FIGURE 24

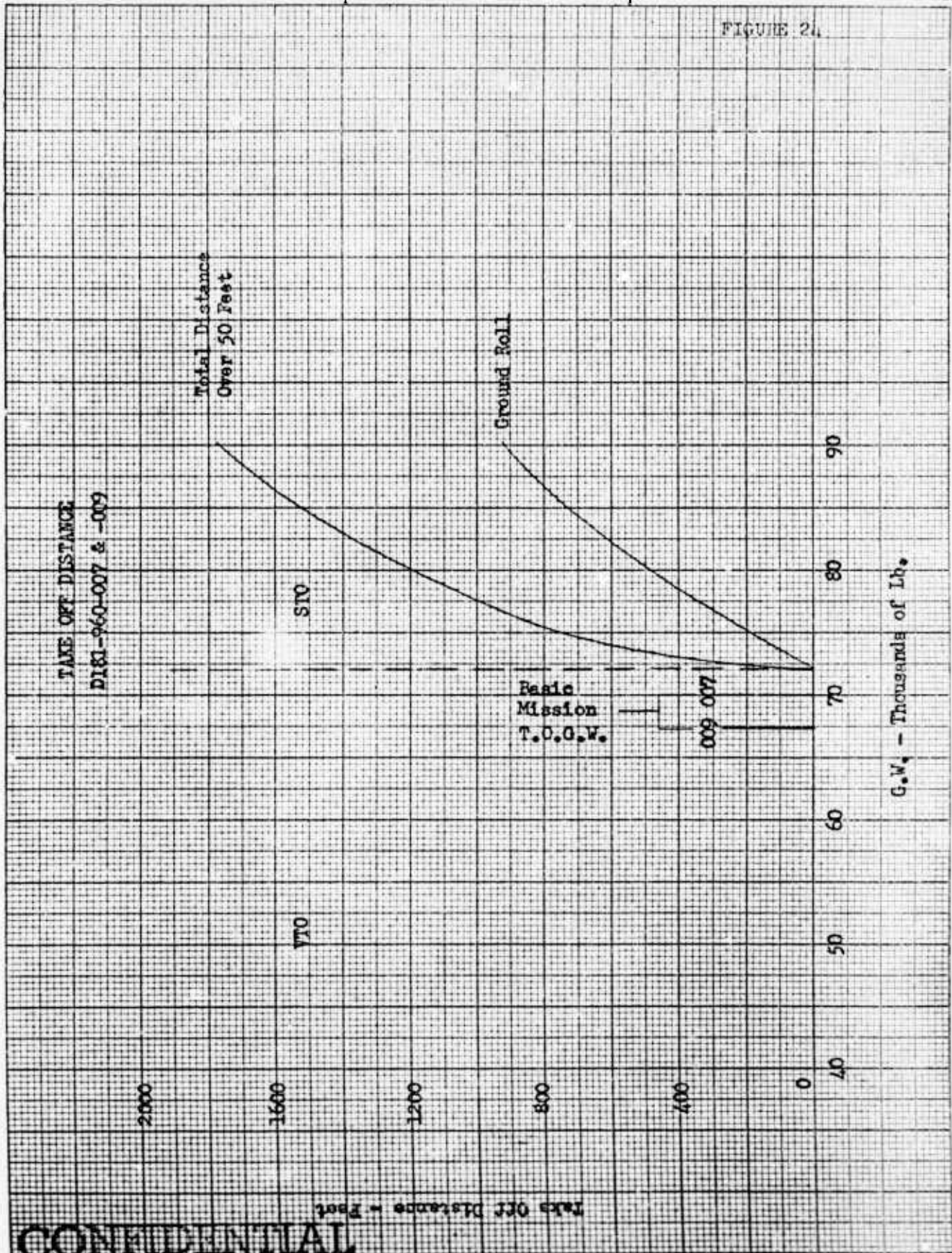

CONFIDENTIAL

Total Distance Over 50 Feet

FIGURE 25

ENGINE FAILURE
DURING HOVERING
D181-960-009

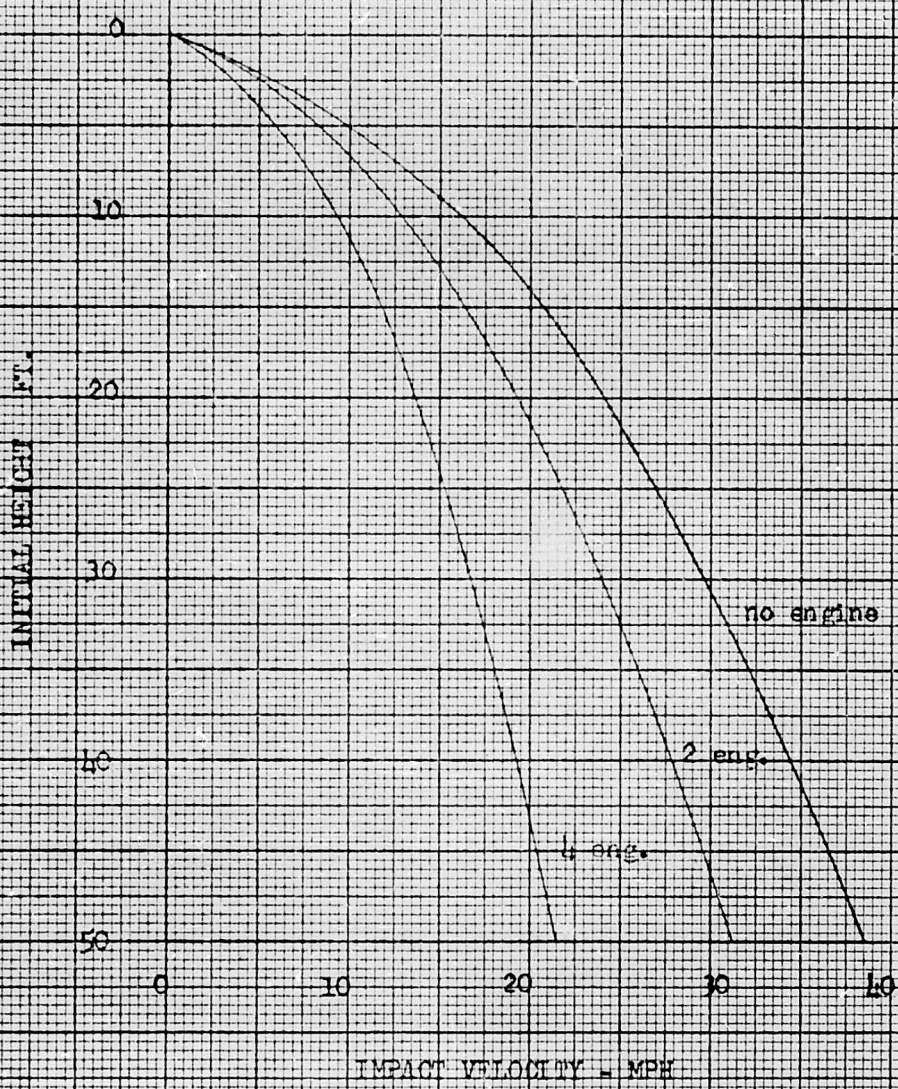
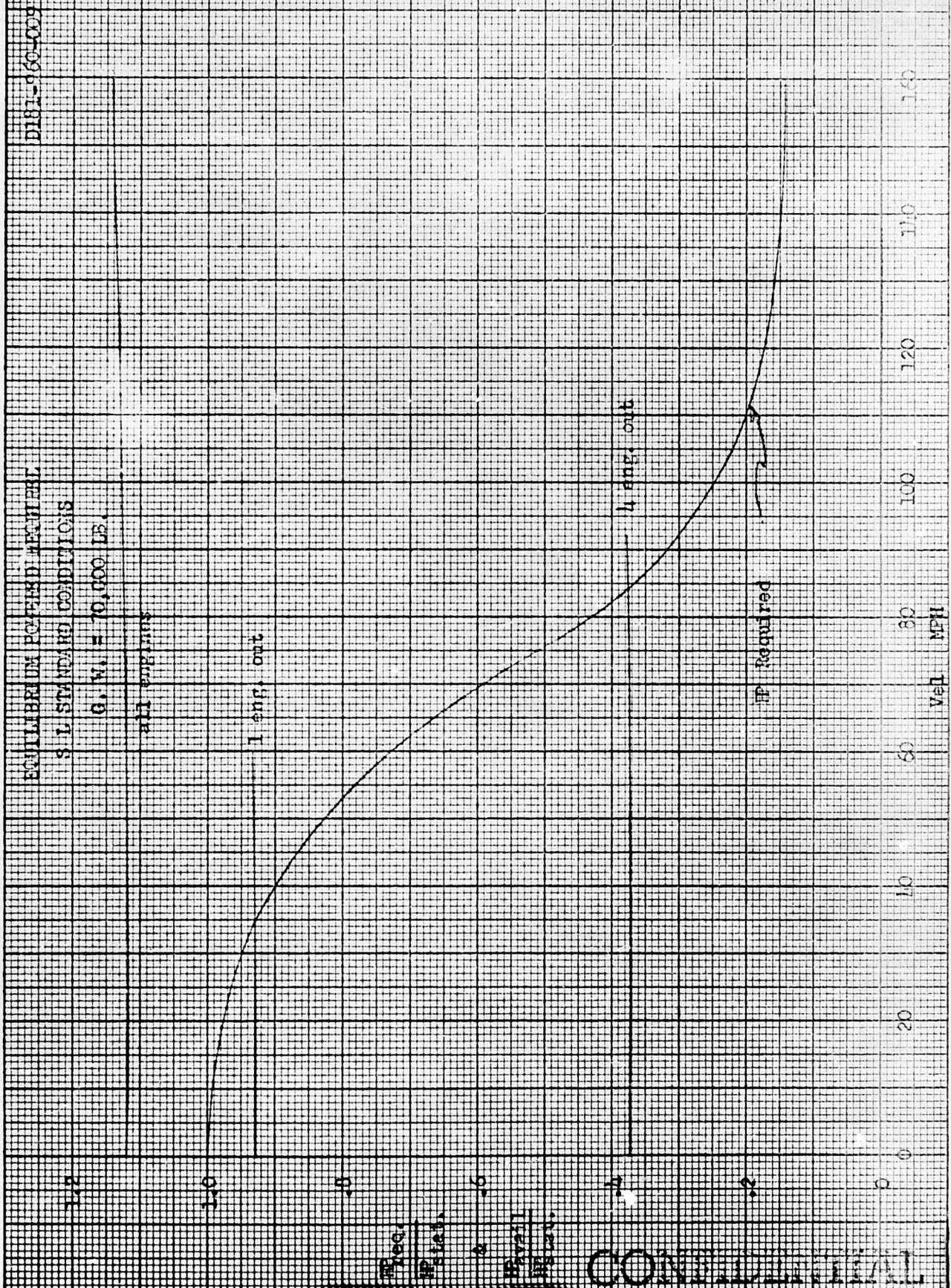

FIGURE 26



CONFIDENTIAL

II. STUDY CONFIGURATION ANALYSIS

The study of configuration 1 was used as the basis for a parametric study of design parameters. The study was made to provide design information for the later configurations. The aspect ratio and wing loading were varied over a large range. The wing loading variation considered changing gross weight on a fixed wing size and fixed gross weight with variable wing size.

II.A. STUDY CONFIGURATION DESCRIPTION

The configuration used in the parametric studied is shown in Figure 27 . It is characterized by ducts mounted at the wing tips and twin booms each housing an engine and supporting the empennage between them. The wing and booms are mounted high on a pod-like fuselage. This first configuration concept had the engines interconnected to provide power to all the propellers without regard to the number of engines operating. In addition, the residual thrust of the Wright T49 engines was ducted aft behind the tail and used to provide the reaction control in pitch, yaw, and roll, required during hovering and transition. Later designs showed that appreciable weight savings could be made if the engines were mounted in the duct hub to take advantage of the residual thrust for vertical lift. Where the residual turboprop thrust was used for lift, an auxiliary power source was placed at the tail of a conventional fuselage for pitch and yaw reaction control while roll control was provided by split flaps in the wing tip ducts. The engines were then electronically interconnected so that power would be delivered symmetrically during low speed flight. In spite of this shift in design thinking, it is felt that this first configuration represents a reliable evaluation of performance parameters.

Table II lists pertinent physical dimensions and parameters for the basic configuration from which the variations in aspect ratio and wing loading were made. In the analysis the aspect ratio was varied from 4 to 10 and the wing loading from 30 to 60 pounds per square foot. The wing loading variation meant a variation of wing area from 1333 feet² at W/S = 30 to 667 square feet at W/S = 60 for an average performance gross weight of 40,000 pounds; it also meant a weight variation from 26,550 pounds at W/S = 30 to 53,100 pounds at W/S = 60 for a wing area of 885 square feet. A rough estimate of the order of magnitude of the gross weight was made to facilitate this parametric study. This estimate subsequently was found to be low; however, the results of the study were not impaired and the basic design parameters were determined at a much earlier date than would have been possible had a careful weight estimate been made first.

The first detailed ducted propeller design was made in conjunction with this analysis. Use was made of available cascade data and the design was made within the limits of this data. As a result, the propeller had 17 fixed pitch blades with a tip solidity of 0.5. Control was achieved by use of variable pitch inlet guide vanes and exit stators were used to remove the rotation from the exiting flow. The details of the design are contained in Reference 1.

II.B STUDY CONFIGURATION PERFORMANCE PARAMETERS

The lift and drag coefficients for the study configurations were estimated using standard Bell Aircraft methods, Reference 5. The lift coefficient as a function of angle of attack and drag coefficient as a

CONFIDENTIAL
BELL *Aircraft* CORPORATION

TABLE II
STUDY CONFIGURATION DATA

WING AND EMPENNAGE

<u>ITEM</u>	<u>UNITS</u>	<u>WING</u>	<u>HORIZONTAL TAIL</u>	<u>VERTICAL TAIL (each)</u>
Area (S)	feet ²	885	178	100
Span (b)	feet	76	25.7	12.2
Aspect Ratio (AR)		6.52	4.0	1.49
Thickness/Chord	%	12	10	10

FUSELAGE AND NACELLES

		<u>FUSELAGE</u>	<u>NACELLES (each)</u>
Frontal Area (F)	feet ²	140	17
Diameter (d)	feet	13.3	3.8
Length (l)	feet	47.5	38.8
Fineness Ratio (FR)		3.57	10

Average Performance Gross Weight 40,000 pounds

Payload 8,000 pounds

Power Plants 2 T49 Turboprop engines

Ducts

Diameter at Propeller 11.6 feet

Diameter Max. Flaps Retracted 12.5 feet

Diameter Inlet Flaps Extended 15.5 feet

Diameter Hub/Diameter Propeller .4

Propeller and Stators

18 variable pitch inlet guide vanes

17 fixed pitch rotor blades

19 fixed pitch exit stators

function of lift coefficient for the basic configuration is shown in Figure 28. This was the aspect ratio of 6.52, wing loading of 45.2 pounds per square foot and wing area of 885 square feet. Figure 29 shows the drag coefficient as a function of lift coefficient for aspect ratios 10, 8, 6.52, and 4. The wing area and wing loading are the same as the basic configuration. The effect on the drag coefficient of increasing wing area at constant weight and aspect ratio is shown in Figure 30. This curve represents a variation in wing loading from 30 to 60 pounds per square foot at the basic aspect ratio of 6.52. The analysis of the variation of wing loading at constant wing area was made using the drag coefficient for an aspect ratio of 8 shown in Figure 29.

The engine characteristics, shown in Figure 31, were taken from the manufacturers specification (Reference 6) and corrected for installation losses as specified. Gearing and other losses totaling about 7% were added. These engine power and fuel flow characteristics were used in conjunction with the momentum analysis of Reference 1 to determine the ducted propeller propulsion characteristics. The method of thrust and fuel flow estimation is explained in Section III.B of this report. The Wright T49 engine had a weight to power ratio of .479 and a rated specific fuel consumption of .76. This engine had rather high fuel consumption and weight to thrust when compared with other gas turbine engines. It was used in this phase of the study to provide a measure of conservatism to the results.

II.C STUDY CONFIGURATION PERFORMANCE

The results of the parametric analysis of the performance of the study configuration are presented in Figures 27 through 52. The basic

assault transport mission was used to evaluate the results of this study. In addition a general analysis of vertical take-off was made for this configuration. The results of this study are shown in Figures 53 through 55.

The aspect ratio variation showed an increased performance advantage with increased aspect ratio; that is the fuel to perform the basic mission decreased, the ceilings increased, and the rates of climb increased. On the other hand the wing weight increased. When the fuel saving is offset by the increase in wing weight, a region of minimum weight results which extends from about aspect ratio 5 to 7. The other advantages of high aspect ratio led to a choice of the range of aspect ratio from 6 to 7.

The results of the wing loading variation study showed that with constant weight or variable wing area, the minimum weight of fuel plus wing occurred at a wing loading of 53 pounds per square foot. With constant wing area the fuel to complete the mission decreased as the wing loading or gross weight decreased. These effects combine to make the best wing loading slightly lower than that indicated from wing area variation alone, and led to the choice of a range of wing loading from 40 to 60 pounds per square foot.

Since the wing weight per unit area will vary from one design to another the weight factor cannot be tied into a parametric study with great accuracy. The results of the study led to an aspect ratio range of 5 to 7 and a wing loading range of 40 to 60 pounds per square foot. These results were incorporated into the later designs.

II.C.1. CLASSICAL PERFORMANCE

The classical performance parameters for this configuration are presented as functions of aspect ratio and wing loading. A standard presentation of classical performance is made in Figure 33 for the basic configuration, aspect ratio 6.52, wing loading 45.2 pounds per square foot, at a gross weight of 40,000 pounds with military power. The airplane had a high speed of 430 mph at 27,000 feet, a sea level rate of climb of 11,560 feet per minute, and a time to climb to 30,000 feet of 4.1 minutes. The absolute ceiling was 47,000 feet, service ceiling 46,600 feet and combat ceiling 45,500 feet.

The variation of best rate of climb with aspect ratio and wing loading is shown in Figures 34, 35, and 36. Figure 34 shows the variation with aspect ratio. The variation is non-linear with the largest change occurring at the low aspect ratio. However, the rate of climb increases with increasing aspect ratio over the range investigated. The effect is largest at altitude. At sea level the rate of climb varies from 11,320 fpm at aspect ratio of 4 to 11,780 fpm at aspect ratio 10, an increase of 4%; while at 35,000 feet the rate of climb goes from 2,250 fpm at aspect ratio 4 to 3,500 fpm at aspect ratio 10, an increase of 11%.

Figure 35 shows the variation of rate of climb with wing loading at constant gross weight or variable wing area. At sea level the rate of climb increases with increasing wing loading and peaks at a value of about 55 pounds per square foot. A peak also appears at 15,000 feet at a wing loading of 35 pounds per square foot. At 25,000 and 35,000 feet the rate of climb decreases with wing loading over the range examined. This phenomenon may be explained on the basis of the level flight drag. An increase

in wing loading causes an increase in lift coefficient required for level flight with an increase in the induced and attitude drag. At the same time the reduction in wing area results in a decrease in the zero lift drag. At low values of lift coefficient a net decrease in drag results while at higher lift coefficients an increase in drag results. The net change in drag reflects directly as a change in excess power available and therefore in rate of climb at fixed conditions of velocity and altitude.

The variation in rate of climb with wing loading with fixed wing area, variable gross weight, is shown in Figure 36. The effect of increasing gross weight outweighs the effects of variation in drag and the rate of climb decreases with increasing wing loading.

The effects of varying aspect ratio and wing loading on the range in climb to 35,000 feet, the fuel to climb to 35,000 feet and the absolute ceiling of the airplane are shown in Figures 37 through 45. Figures 37, 38 and 39 are for variable aspect ratio. The range in climb (Figure 37) and the fuel to climb (Figure 38) are directly related to the rate of climb as is the ceiling, and decrease with increasing aspect ratio as would be expected. The range in climb to 35,000 feet decreases from 25.2 statute miles to 20.4 miles, a decrease of 19%. The fuel to climb decreases by 14% from aspect ratio 4 to 10. The absolute ceiling (Figure 39) increases from 43,800 feet to 50,000 feet over this aspect ratio range, an increase of 12%.

The variation of these items with wing loading with variable wing area is shown in Figures 40, 41, and 42. The range in climb and fuel to climb increase while the absolute ceiling decreases with increasing

wing loading. Over the wing loading range from 30 to 60 pounds per square foot the ranges in climb increased 21%; the fuel to climb increased 5.4% and the ceiling decreased 8.5%.

The effect of variable gross weight on the wing loading variation is shown in Figures 43, 44, and 45. The direction of change was the same as with variable wing area but as would be expected the change in weight made this effect more pronounced over the range of wing loading from 30 to 60 pounds per square foot, the range in climb increased from 9.8 miles to 33.6 miles, an increase of 275%. The fuel to climb increased from 445 pounds to 1,085 pounds, an increase of 144%, and the ceiling decreased from 55,400 feet to 46,100 feet, a decrease of 17%.

II.C.2. BASIC MISSION

The basic assault transport mission, as defined for this study, consisted of flying a 425 mile radius at 300 mph with vertical take-offs and landings at the end points which are assumed to be at a 6,000 foot altitude on a 95°F day. The airplane was to carry an 8,000 pound payload out and a 4,000 pound payload back, and maintain a 10% fuel reserve. The radius was to consist of cruise at the altitude for long range for 80% of the distance and at sea level for 20% of the distance on both legs. This mission was simplified slightly for this phase of the study. The altitude cruise was made at 35,000 feet on both legs. A single increment of fuel for all take-offs, landings and reserve was used. These assumptions simplified the parametric study without damaging the comparative value of the results.

The variation of the cruise parameter, miles flown per pound of fuel used, as it varied with aspect ratio and wing loading over a range of altitudes from sea level to 35,000 feet is shown in Figures 46, 47, and 48. Figure 46 shows the variation of this parameter with aspect ratio. The miles per pound of fuel increases with increasing aspect ratio at all altitudes. The rate of increase becomes larger as the altitude gets higher. At sea level the miles per pound go from .0350 to .0365 over the aspect ratio range from 4 to 10, a change of 4%. At 35,000 feet the change is from .0833 to .1115 which is 36%. The variation of miles per pound with wing loading with variable wing area is shown in Figure 47. As was the case with the rate of climb the changing wing loading at constant weight causes opposing changes in both lift coefficient and drag. As a result the parameter increases with increasing wing loading at sea level, has a peak value at 15,000 feet, and decreases at 25,000 and 35,000 feet for the range of wing loadings investigated. The variation of the cruise parameter with wing loading and variable gross weight (Figure 48) is dominated by the weight change. The miles per pound decreases with increasing wing loading at all altitudes. As would be expected the change is greatest at the higher altitudes.

The basic mission was calculated as a function of aspect ratio and wing loading, using the data of the preceding curves. Figure 49 shows the variation of total fuel for the basic mission as a function of aspect ratio. The fuel decreases from 14,020 pounds at an aspect ratio of 4 to 12,000 pounds at an aspect ratio of 10. The effect of an assumed increase of wing weight with aspect ratio on the total weight of fuel plus wing is shown in Figure 50. The region of minimum weight falls between

the aspect ratios of about 5 and 7. The variation of weight in this region is very small, 50 pounds out of 14,000 pounds. Between aspect ratios 6 and 7 no noticeable change in weight exists. This fact together with the other advantages of increased aspect ratio, led to the selection of the design range of aspect ratio between 6 and 7.

Figure 51 shows the variation in fuel required to complete the mission as a function of wing loading with variable wing area. At a wing loading of 30 pounds per square foot 12,495 pounds were required. This requirement increased to 13,215 pounds for a wing loading of 60 psf. This is in reality a small change amounting to 6.5%. The assumptions of unit wing weight for this configuration led to a minimum wing plus fuel weight at a wing loading of 53 psf. However, since the total fuel weight change was small, and the unit wing weight is a function of the configuration and cannot be set rigidly, this minimum value of wing loading was used as a guide in selecting a range, rather than as an absolute value. The range was selected considering the data of Figure 52 which shows the variation in fuel as a function of wing loading with constant wing area. The fuel required increases from 11,020 pounds to 13,700 pounds as the wing loading increases from 30 to 60 pounds per square foot.

A consideration of these wing loading effects led to the choice of a rather wide range of wing loadings, between 40 and 60 pounds per square foot at the cruise weight. This wide range would of necessity be narrowed in the detailed consideration of a particular configuration.

II.D. VERTICAL TAKE-OFF STUDY

An analysis of vertical take-off capability as a function of thrust to weight ratio for the study configuration was accomplished.

CONFIDENTIAL
BELL *Aircraft* CORPORATION

The vertical take-off flight path was considered to consist of a vertical rise to hovering at 50 feet, followed by transition to speeds for conventional level flight. The speed during the vertical ascent was limited to 5 feet per second. The transition to level flight was made at low angle of attack and constant altitude by an intermittent rotation of the thrust. The take-offs were made at an altitude of 6,000 feet at a temperature of 95°F. The Wright T49 engines which powered this configuration had a specific fuel consumption of about 0.78. This led to some conservatism in the estimate of fuel required as the engines used later had specifics of about 0.5. The total fuel quantity involved was relatively small so that the effects of this conservatism were negligible. Figure 53 shows the total fuel required to complete the vertical take-off as a function of initial thrust to weight ratio. The time to rise vertically to 50 feet as a function of thrust to weight ratio is also presented in Figure 53. The time to rise decreases rapidly with increasing thrust so that a thrust increment of 3% the time to rise was reduced from 51 to 13.5 seconds. At the same time the fuel required for the take-off decreased from 270 to 67 pounds. If this thrust increment was achieved by a reduction in weight this would mean a reduction of 1,500 pounds for an available thrust of 50,000 pounds. If all this weight was fuel, the utilization of a 3% thrust margin would result in a net fuel reduction of 1,300 pounds by the time the plane was airborne. This example demonstrates that the most fuel, or payload, can be taken aloft from an initial thrust weight ratio of one. Figure 54 presents still another facet of the problem. In this figure, the time required to accelerate vertically to 5 feet per second and the altitude attained at the end of the acceleration

CONFIDENTIAL
BELL *Aircraft* CORPORATION

are plotted as functions of the initial thrust to weight ratio. With thrust initially equal to the weight, 5 feet per second is not attained before 50 feet is reached. Using a 3% thrust margin the rise velocity is reached in 5 seconds at an altitude of 12 feet. In order to obtain a positive lift off and acceleration in vertical flight this analysis indicates that a 3% thrust margin at take off for a ducted propeller VTOL is desirable. This differs from previous studies with VTOL aircraft which have shown that the high rate of fuel flow characteristic of turbo-jets made a vertical take off with the initial thrust equal to weight feasible. A sample time history of the vertical take off is shown in Figure 55. This take off was calculated from an initial thrust to weight ratio of 1.02. Presented are the variations with time of velocity, altitude, range, and thrust direction. The time history illustrates the intermittent thrust rotation, and the resulting velocity and distance variations. The vertical rise to 50 feet was completed in 14.8 seconds. A vertical velocity of 5 feet per second was attained in 7.6 seconds at an altitude of 17 feet. The acceleration to flying speed was accomplished in an additional 14 seconds, when a velocity of 208 feet per second was reached. The thrust rotation was accomplished intermittently at a fixed rate of 15 degrees per second. The total time was 28.8 second and a distance of 1020 feet was covered during the acceleration.

CONFIDENTIAL

STUDY CONFIGURATION

FIGURE 27

D181-960-001

2 Wright T49-W-1
Engines

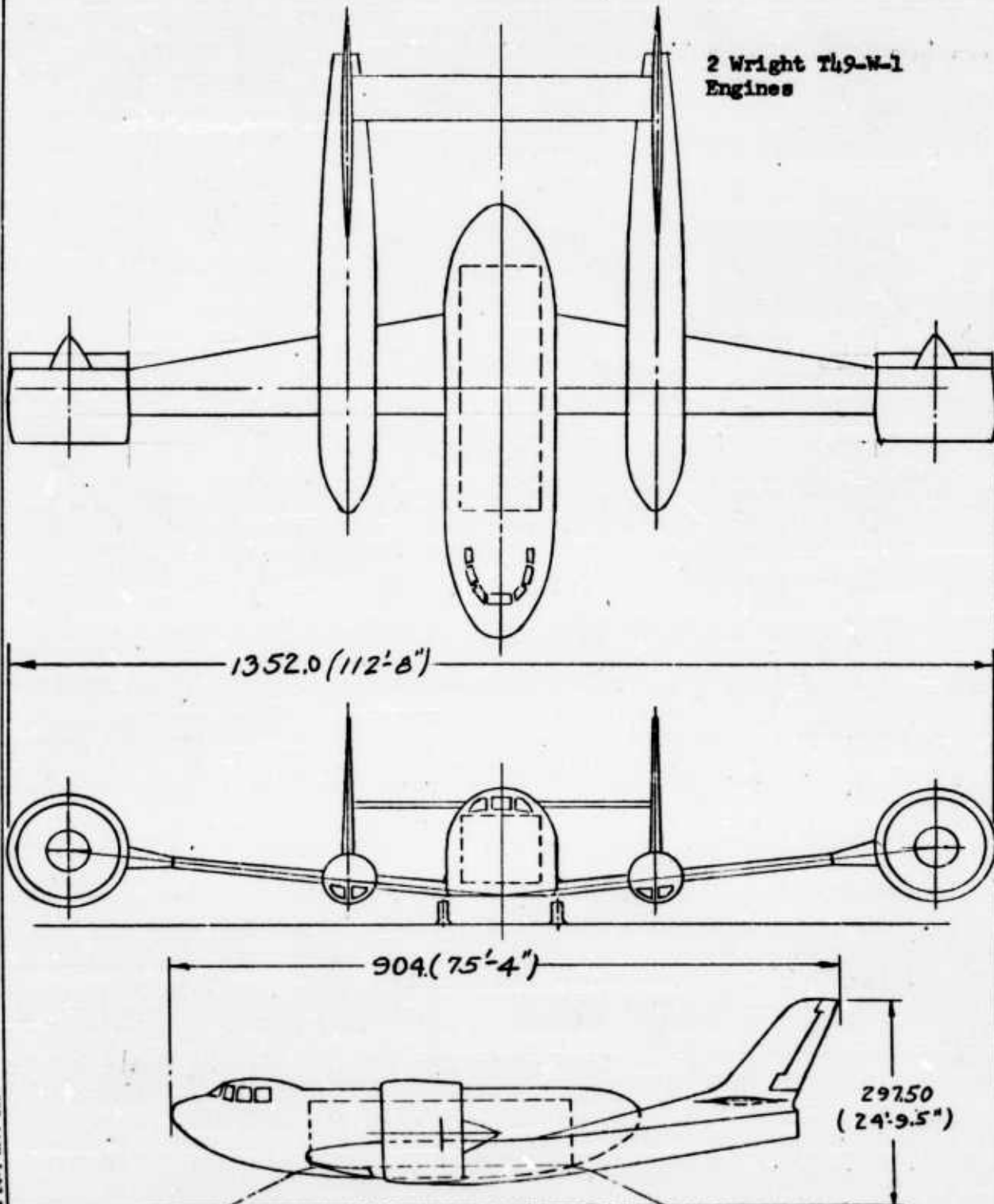

Rev. 353

1/200
50

CONFIDENTIAL

CONFIDENTIAL

FIGURE 26

LIFT & DRAG COEFFICIENT

D 181-960-001

S=885

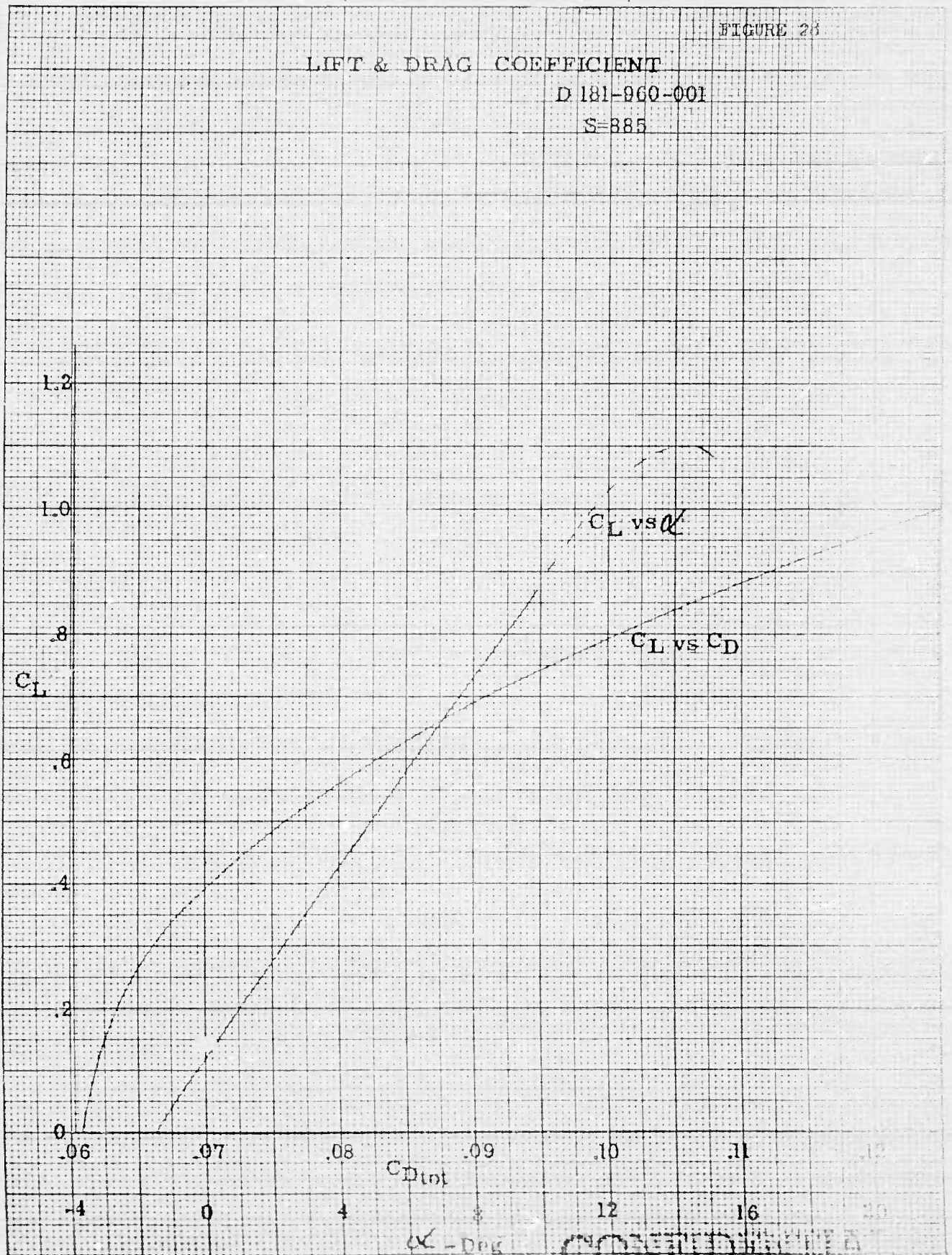

CONFIDENTIAL

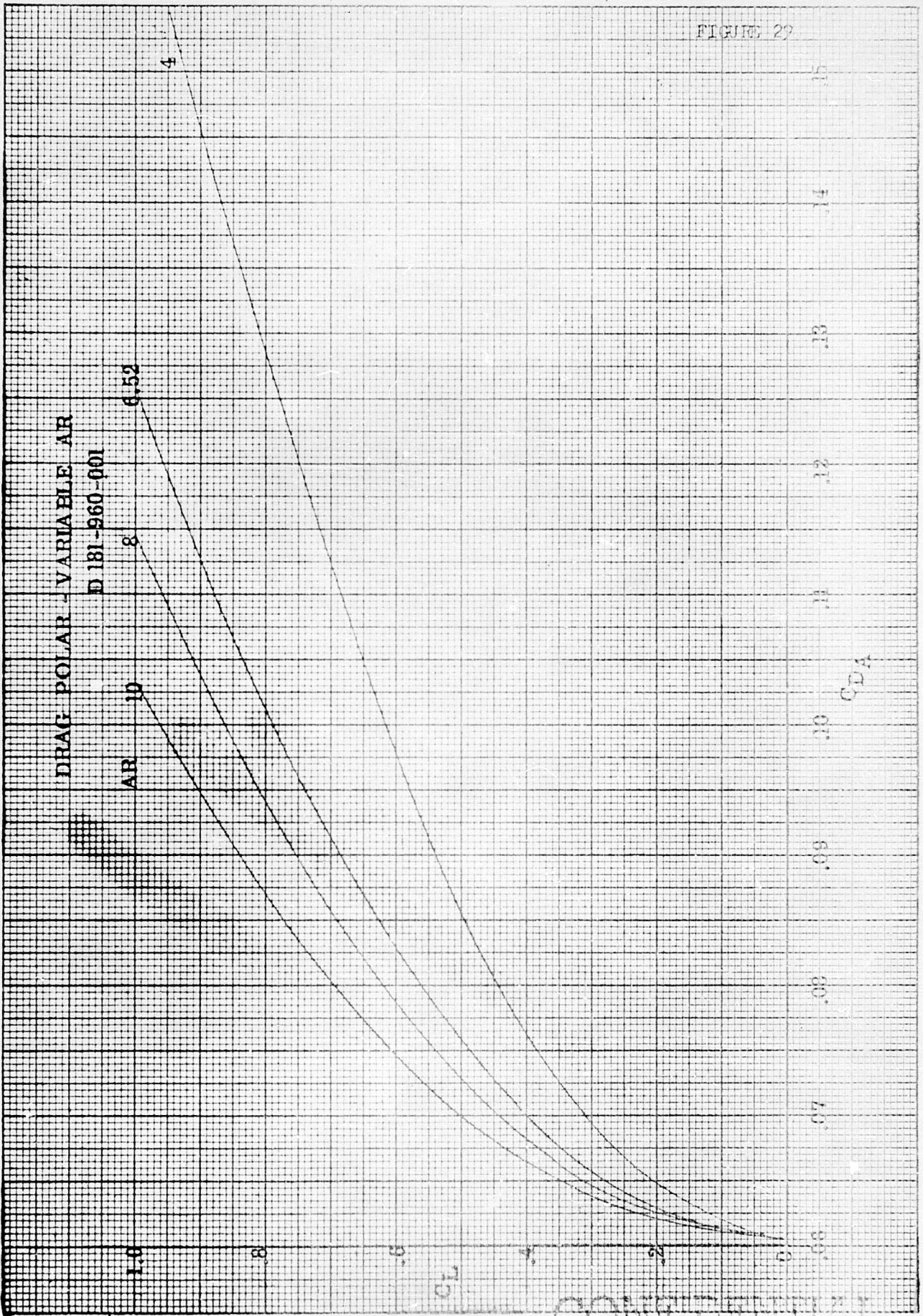

FIGURE 29

DRAG POLAR - VARIABLE AR

D 181-960-001

AR 10

8

6.52

CL

CD

CONFIDENTIAL

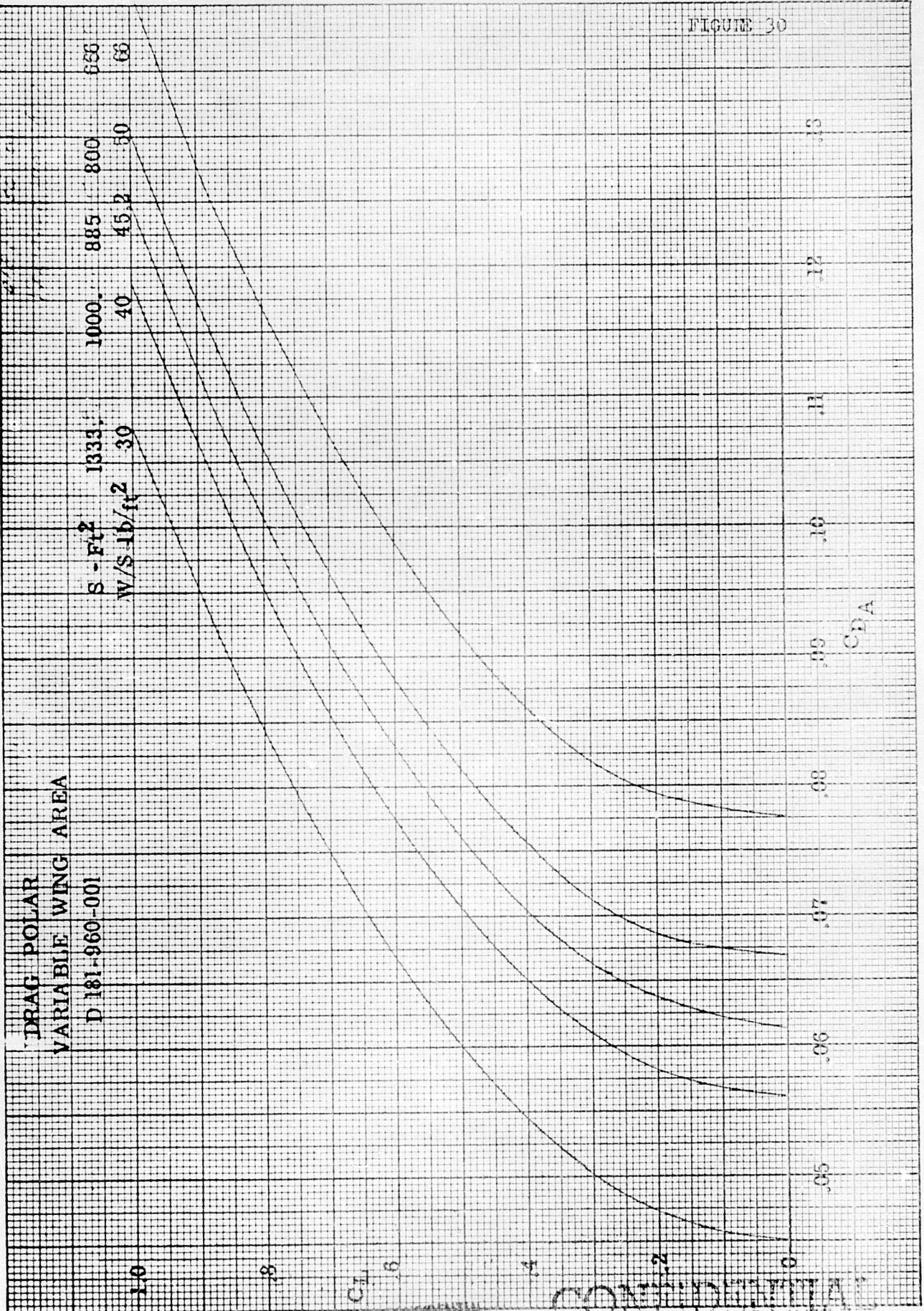

CONFIDENTIAL

FIGURE 31

POWER AVAILABLE
WRIGHT T19-W-1
97% Pressure Recovery
2% Gear Losses

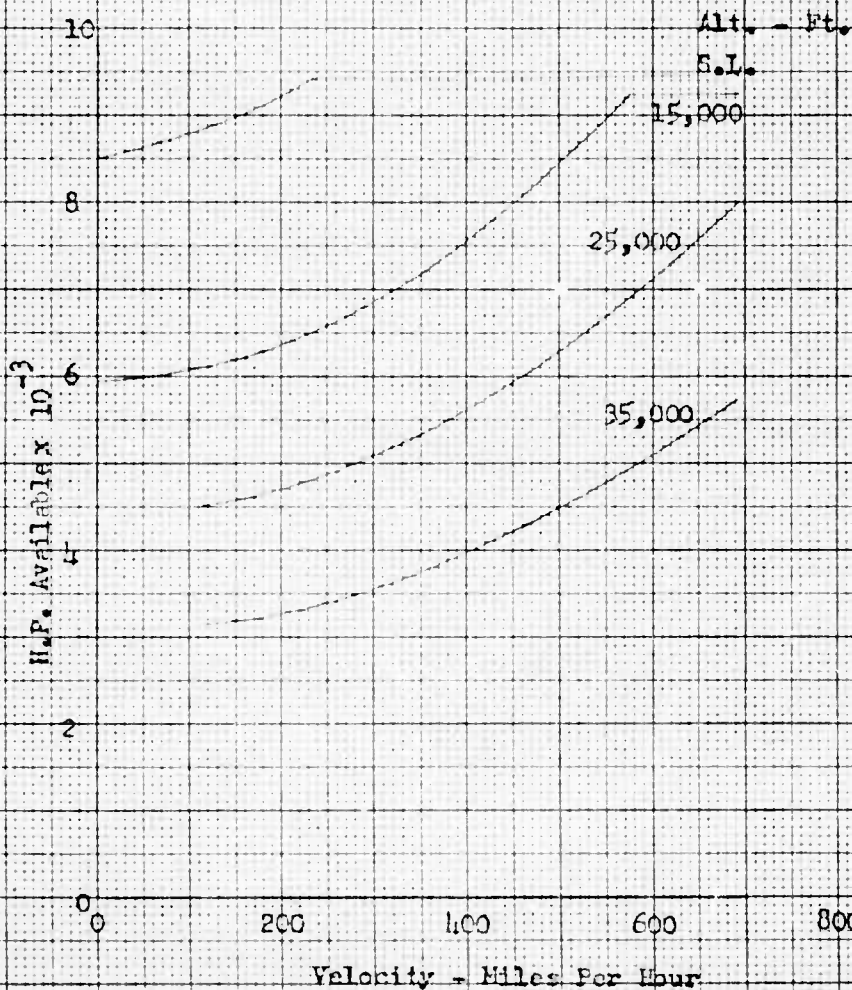
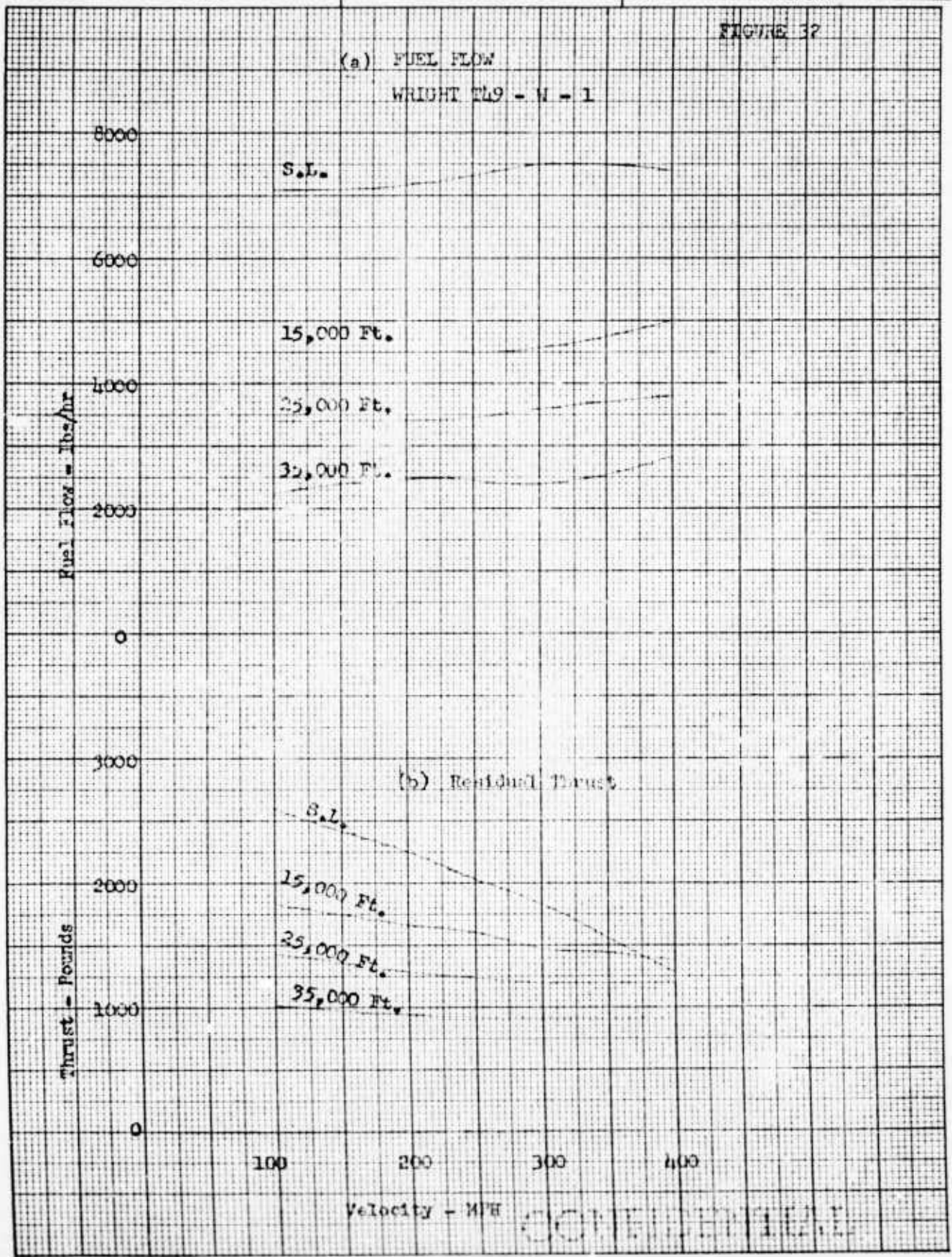
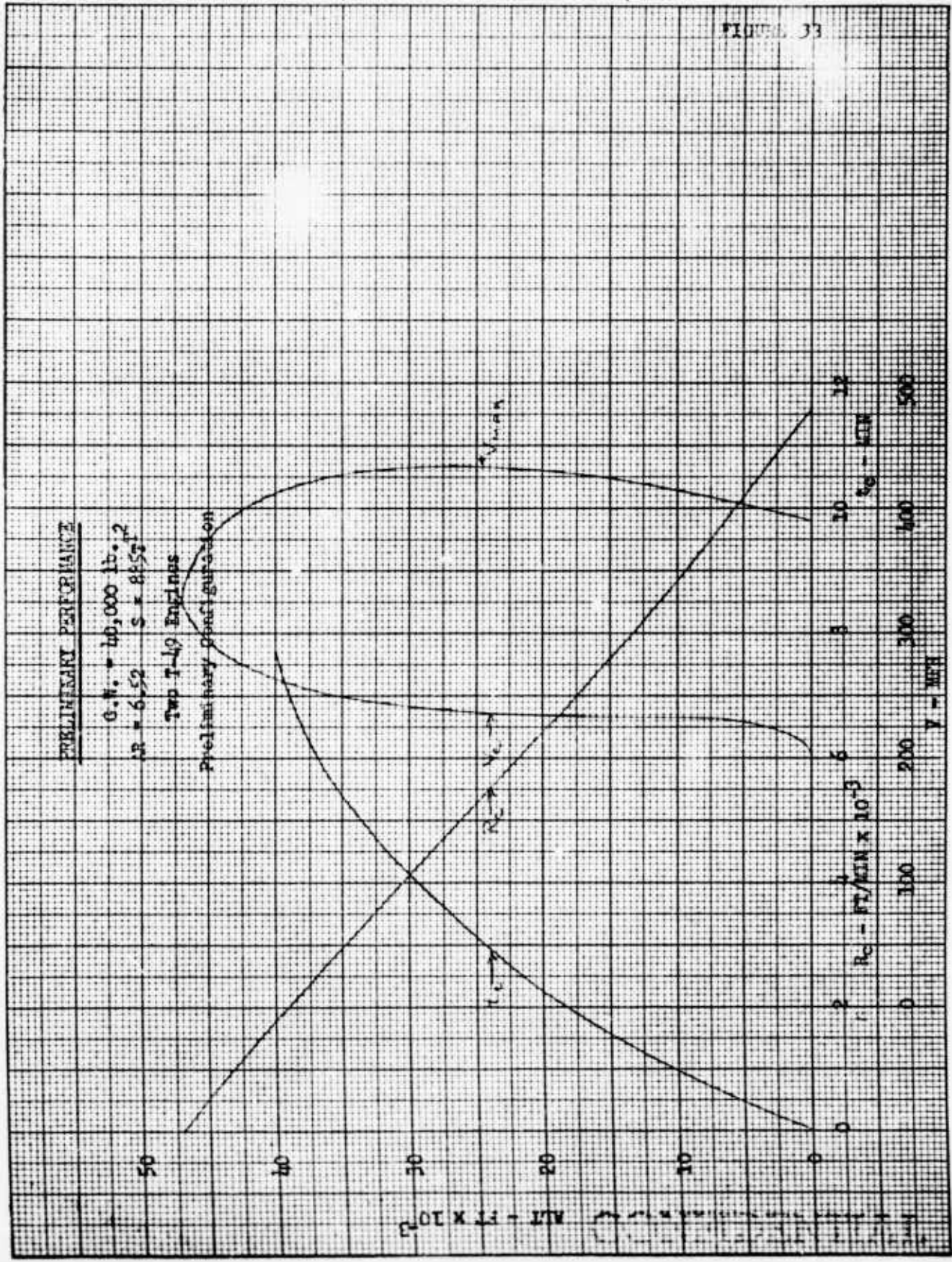

FIGURE 32





BY _____ DATE _____
CHECKED _____ DATE _____

BELI

CONFIDENTIAL
CORPORATION

MODEL _____ PAGE 72
SHIP _____ REPORT D181-745-001

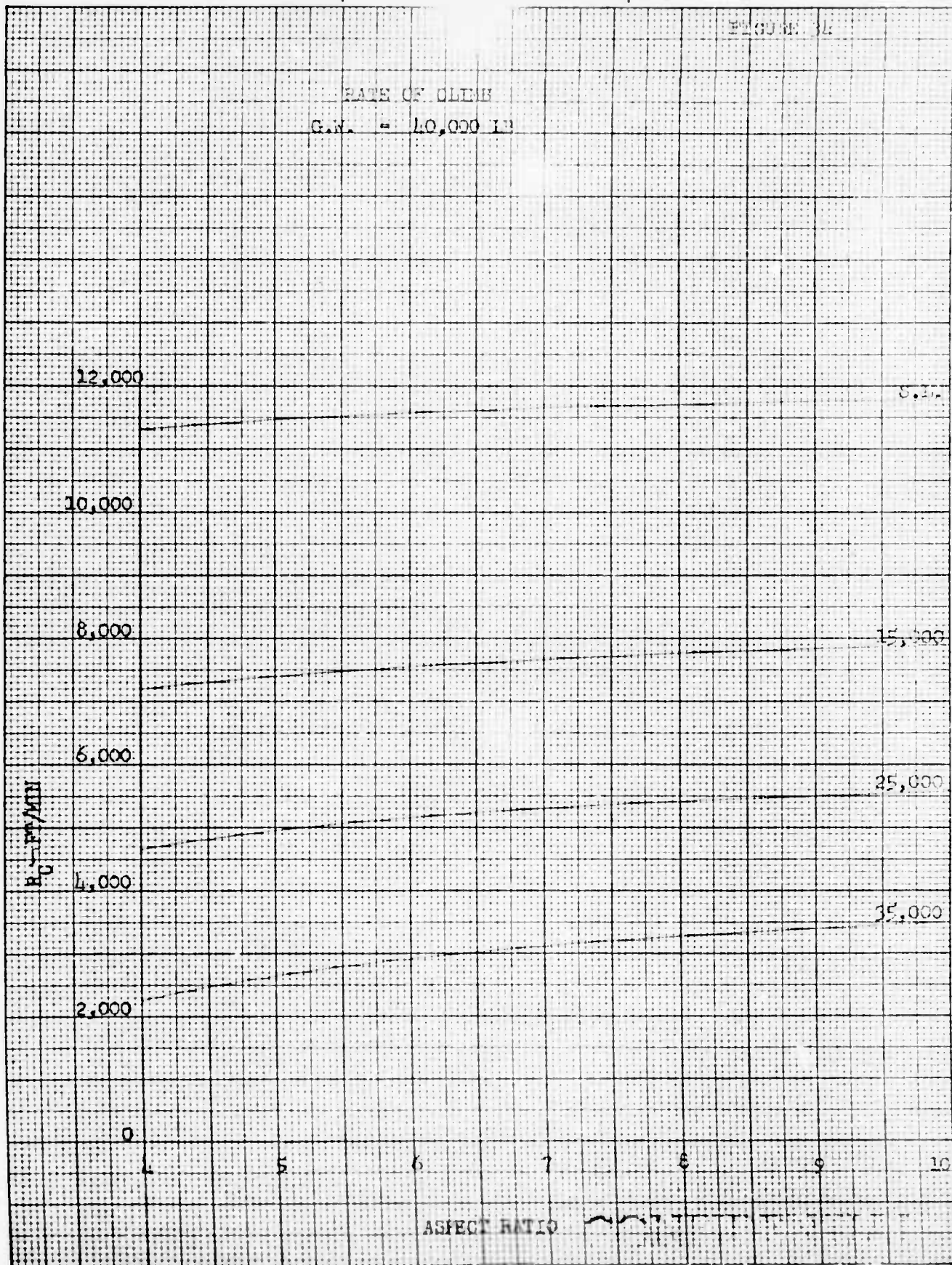

RATE OF CLIMB - VARIABLE WING AREA

FIGURE 35

Performance Weight = 40,000 lb.

AR = 6.52 Two T-19 Engines

Configuration No. 1

12000

S.L.

10000

8000

15,000'

R_c - Ft/min.

6000

25,000'

4000

35,000'

2000

0

30

40

50

60

V/S

CONFIDENTIAL

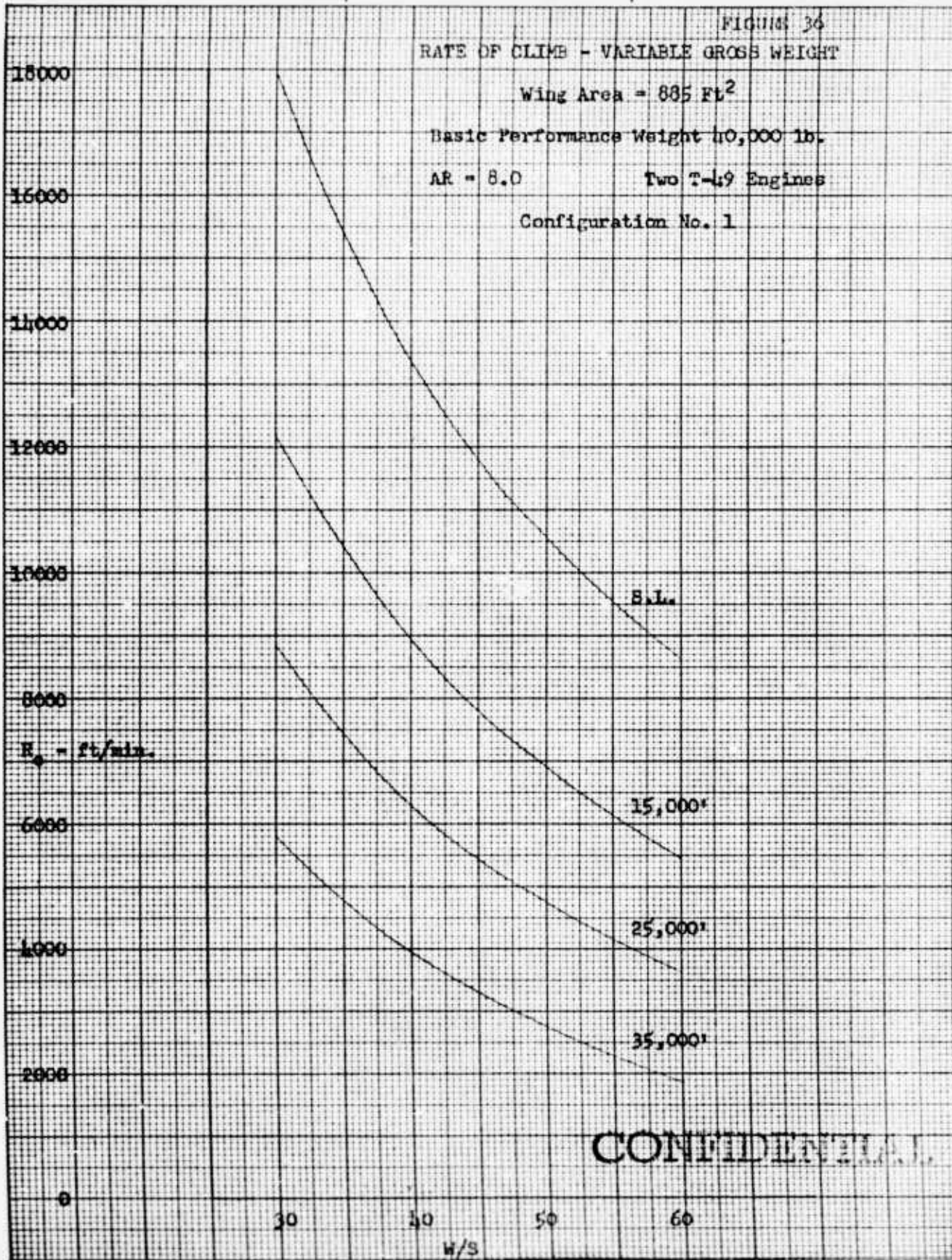

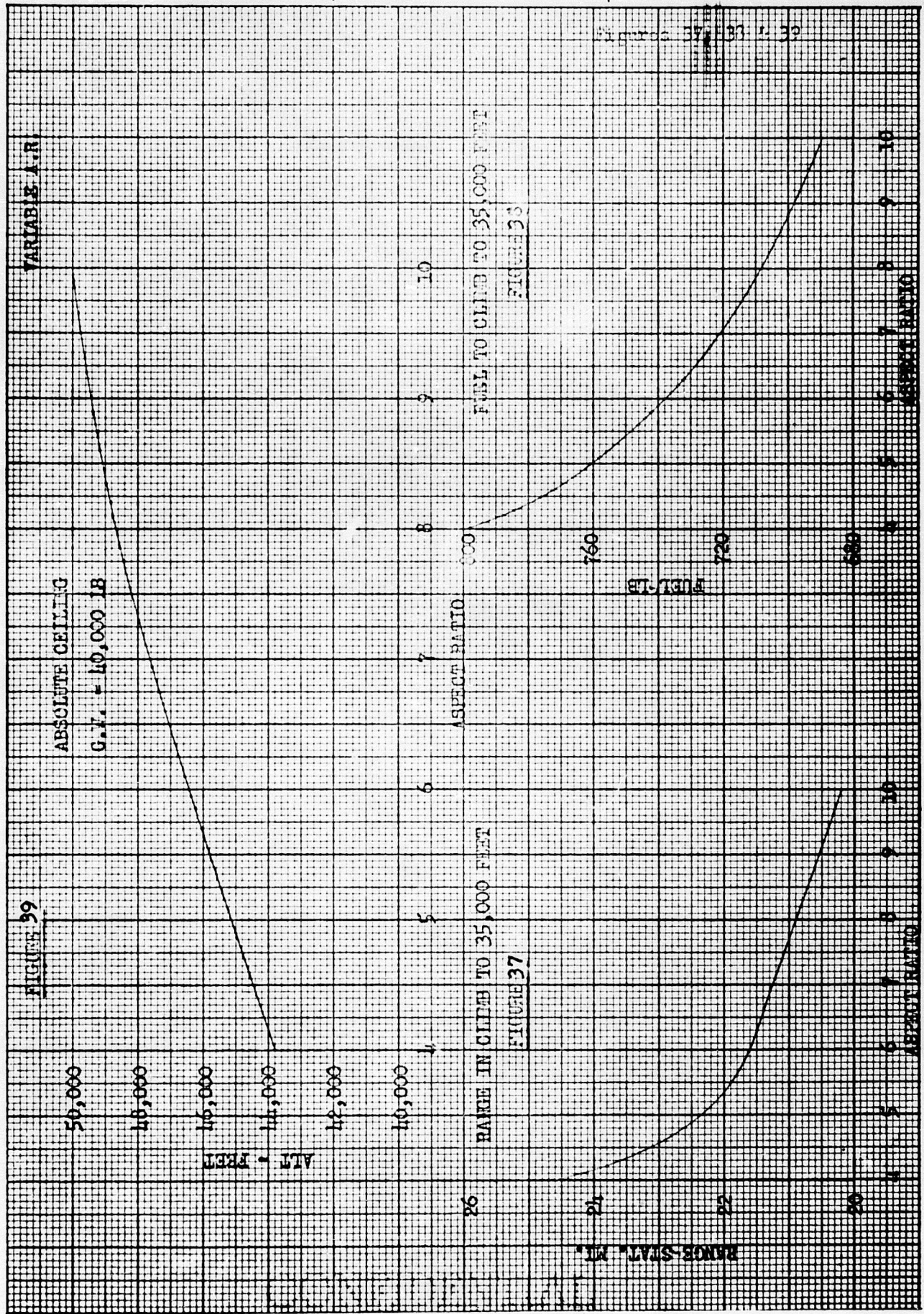

March 31 1939

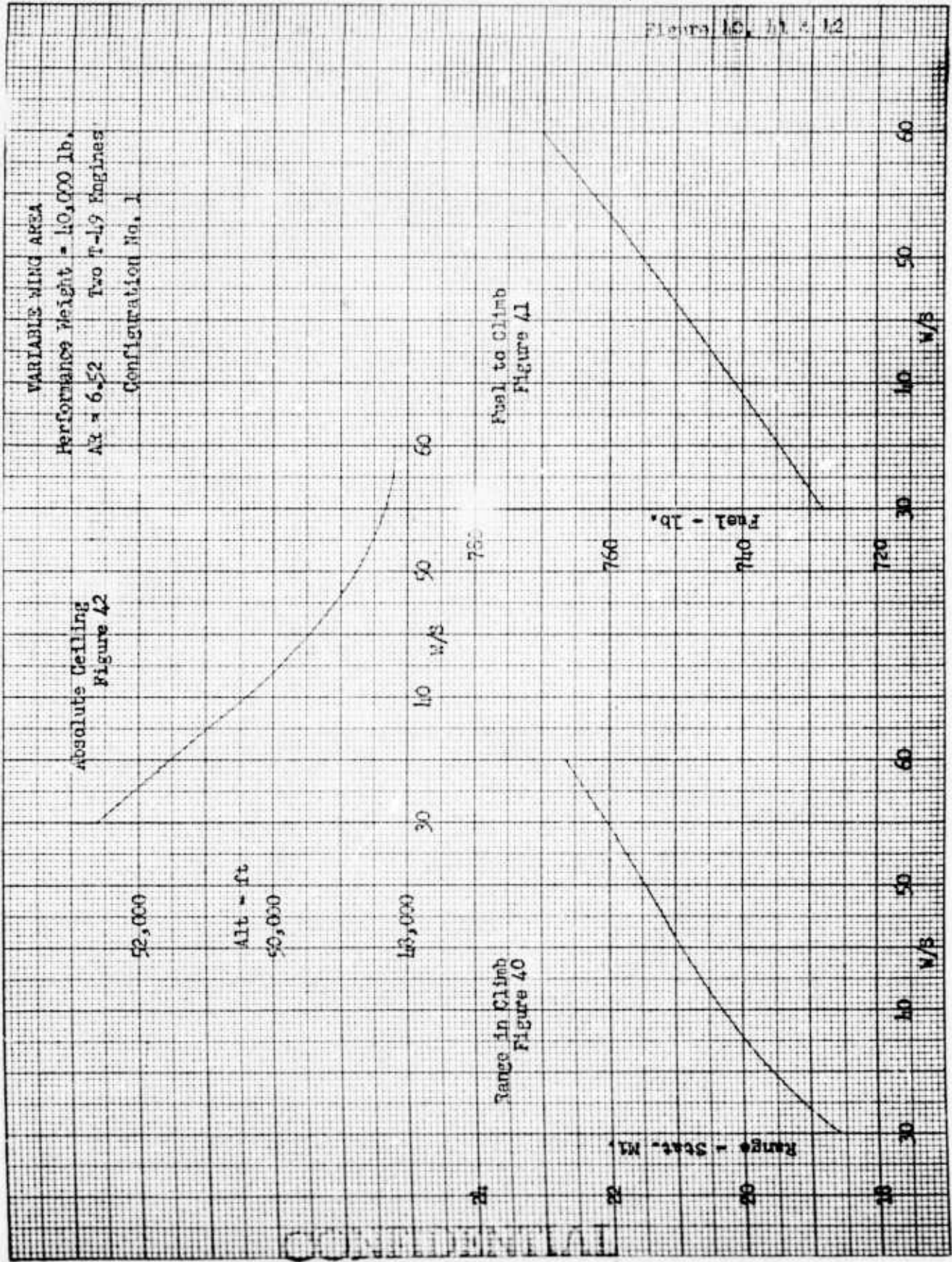

CONFIDENTIAL

Figures 43, 44, & 45

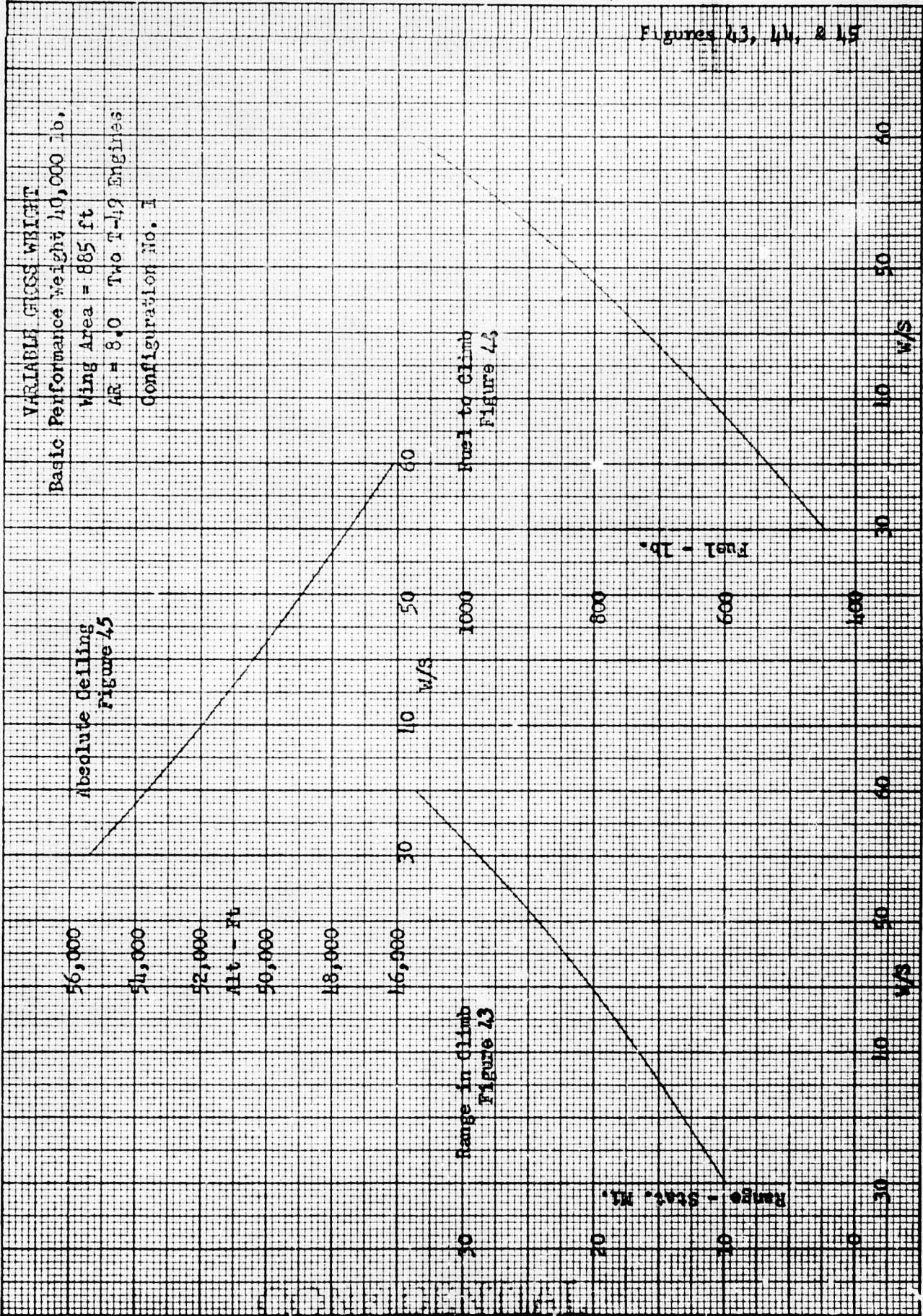

VARIABLE GROSS WEIGHT
 Basic Performance Weight 10,000 lb.
 Wing Area = 885 ft²
 AR = 8.0 Two T-19 Engines
 Configuration No. 1

Absolute Ceiling
 Figure 45

Range in Climb
 Figure 43

Fuel to Climb
 Figure 44

Range - Stat. Mi.

Fuel - lb.

56,000

54,000

52,000

Alt - Ft

50,000

48,000

46,000

50

40

30

0

30

10 w/s

50

60

1000

800

600

400

10 w/s

50

60

50

60

1000

60

10 w/s

60

CRUISE PARAMETER

G.W. = 40,000 LB

VARIABLE A.R.

FIGURE 16

35,000

25,000

15,000

5,000

X_{RES}/LB

.11

.10

.09

.08

.07

.06

.05

.04

.03

4

5

6

7

8

9

10

ASPECT RATIO

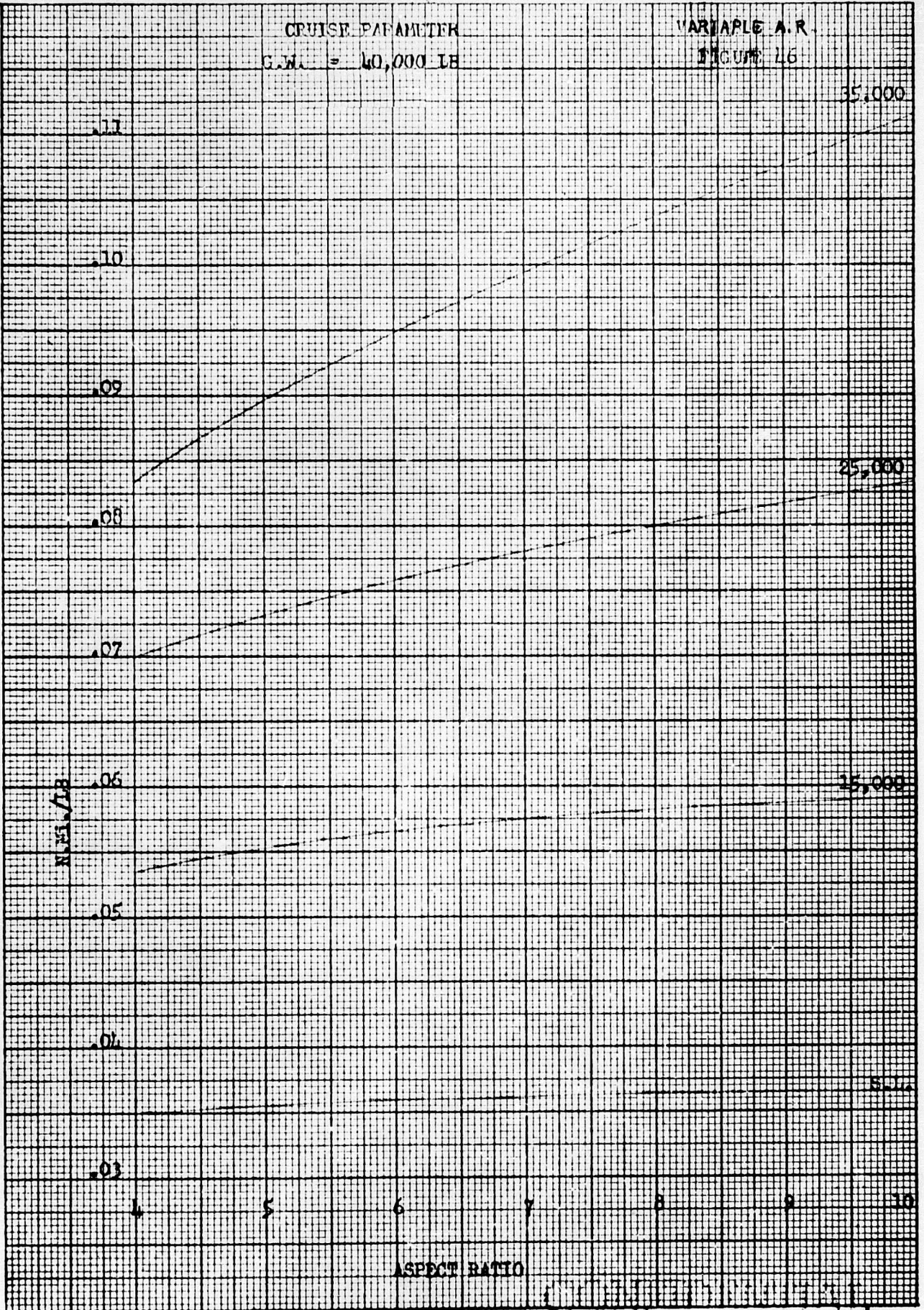

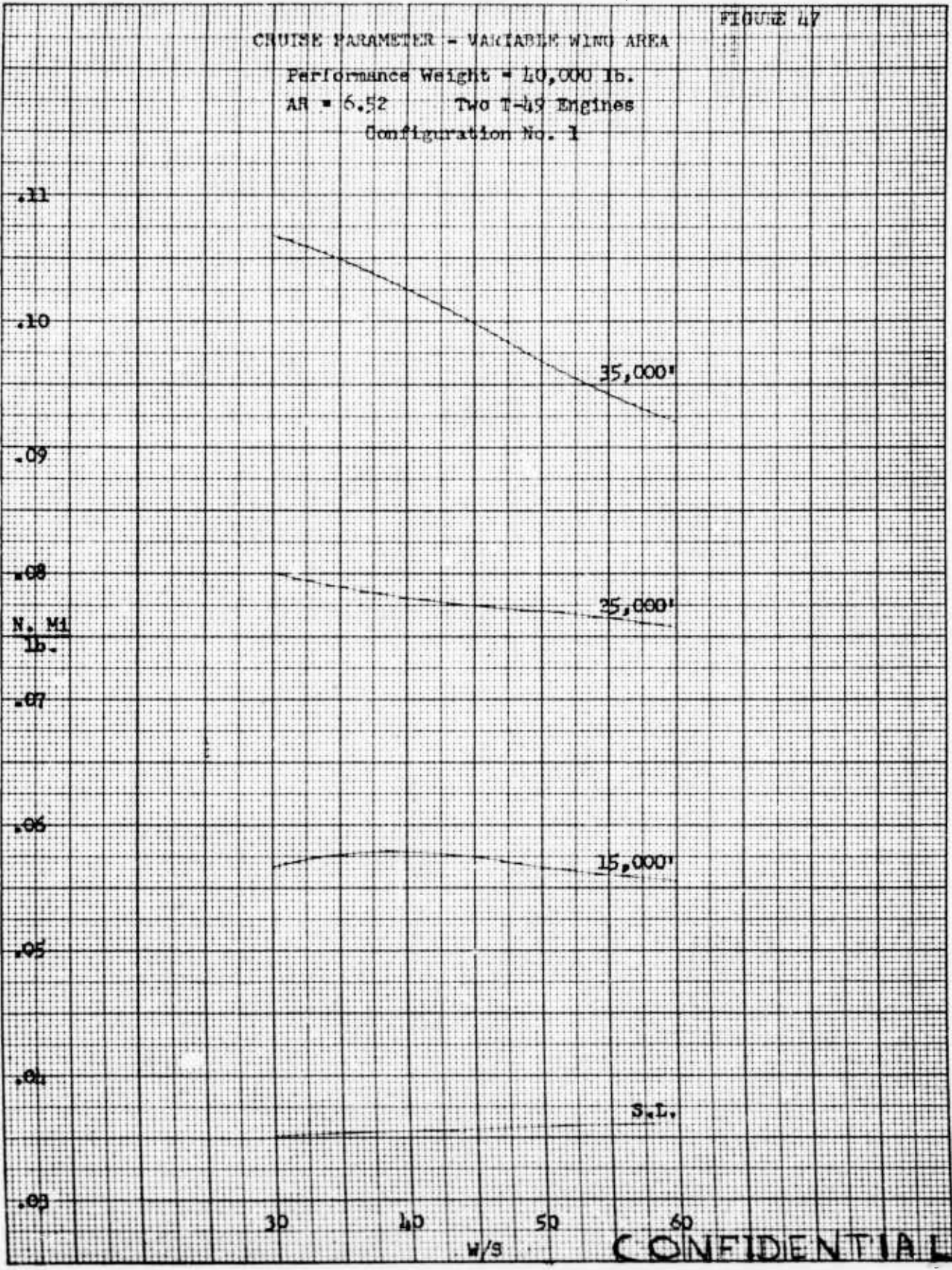

CONFIDENTIAL

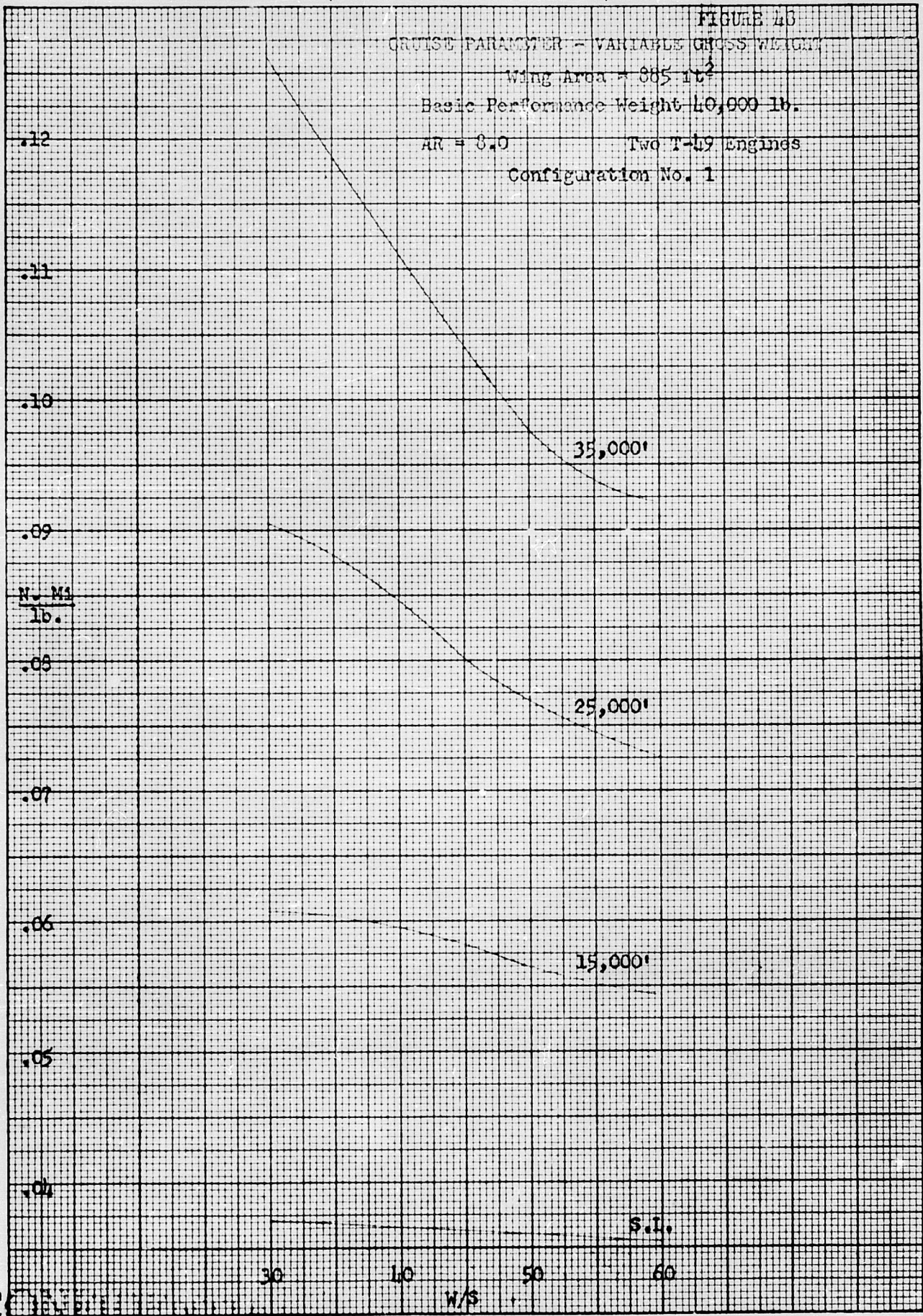

C

FIGURE 49

TOTAL FUEL TO COMPLETE BASIC MISSION
GW = 10,000 LB

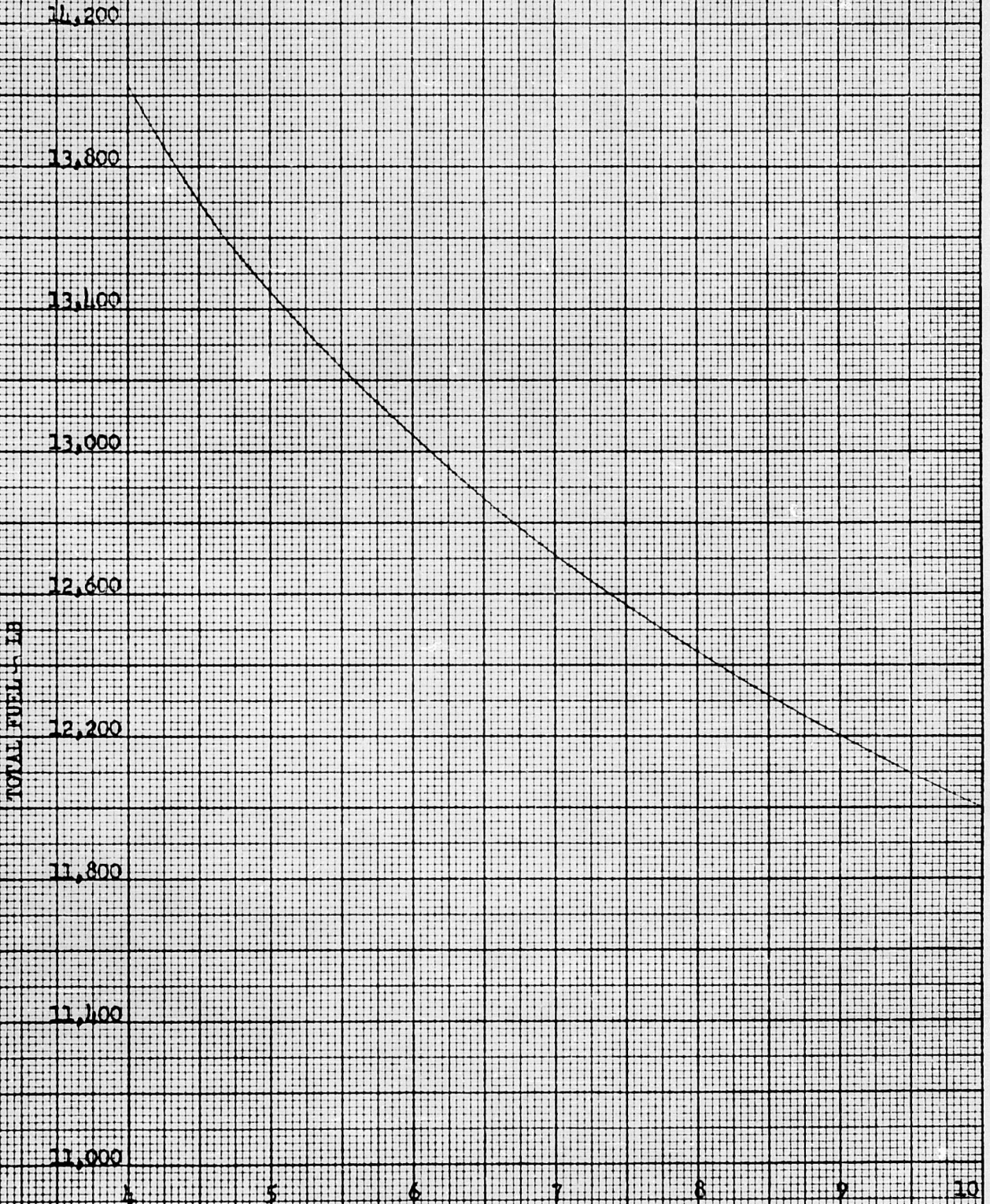

ASPECT RATIO

CONFIDENTIAL

BY _____ DATE _____
CHECKED _____ DATE _____

BELL Aircraft CORPORATION

MODEL _____ PAGE 82
SHIP _____ REPORT D181-945-004

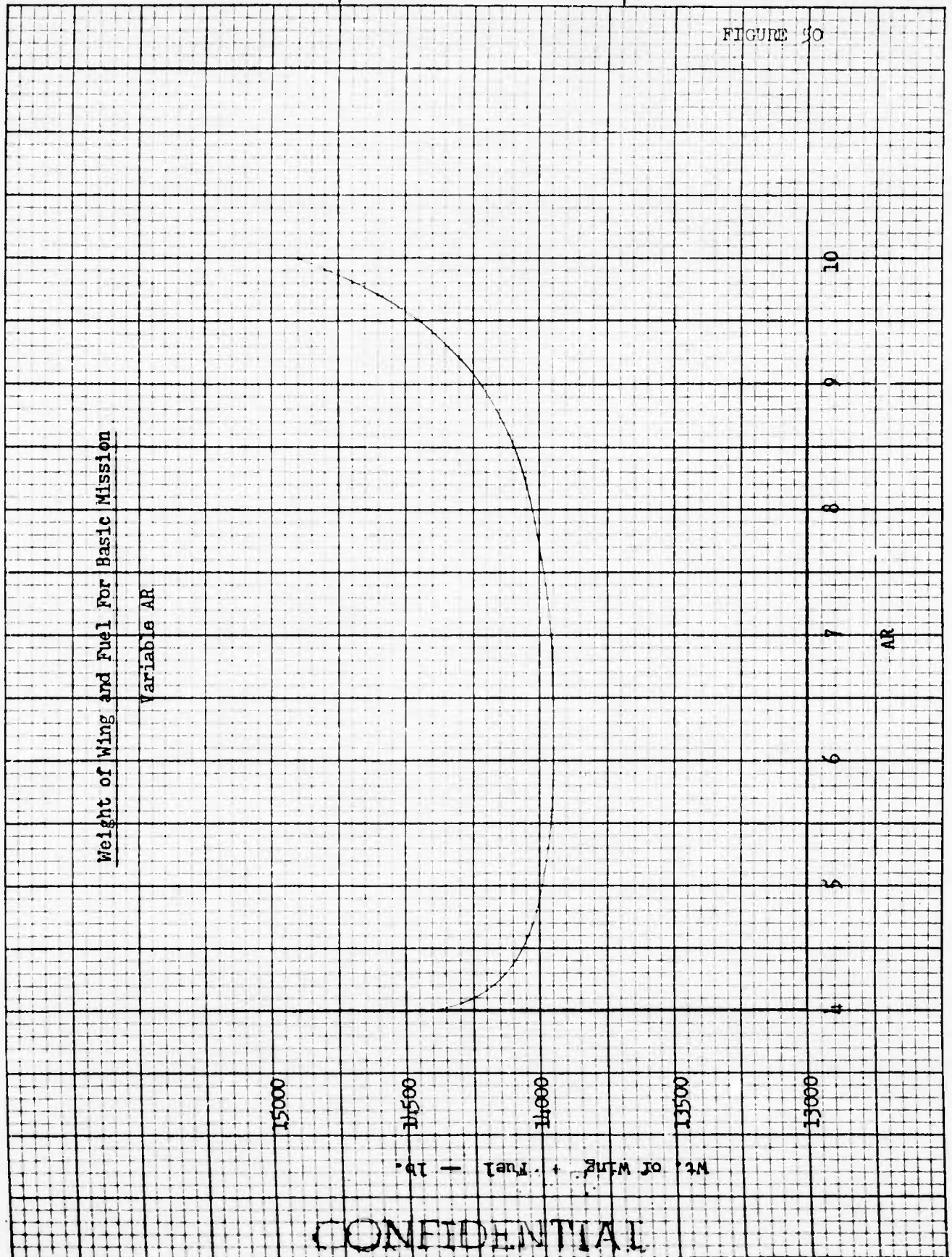

BY _____ DATE _____
CHECKED _____ DATE _____

BELL Aircraft CORPORATION

CONFIDENTIAL

MODEL _____ PAGE 82
SHIP _____ REPORT D181-945-004

FIGURE 50

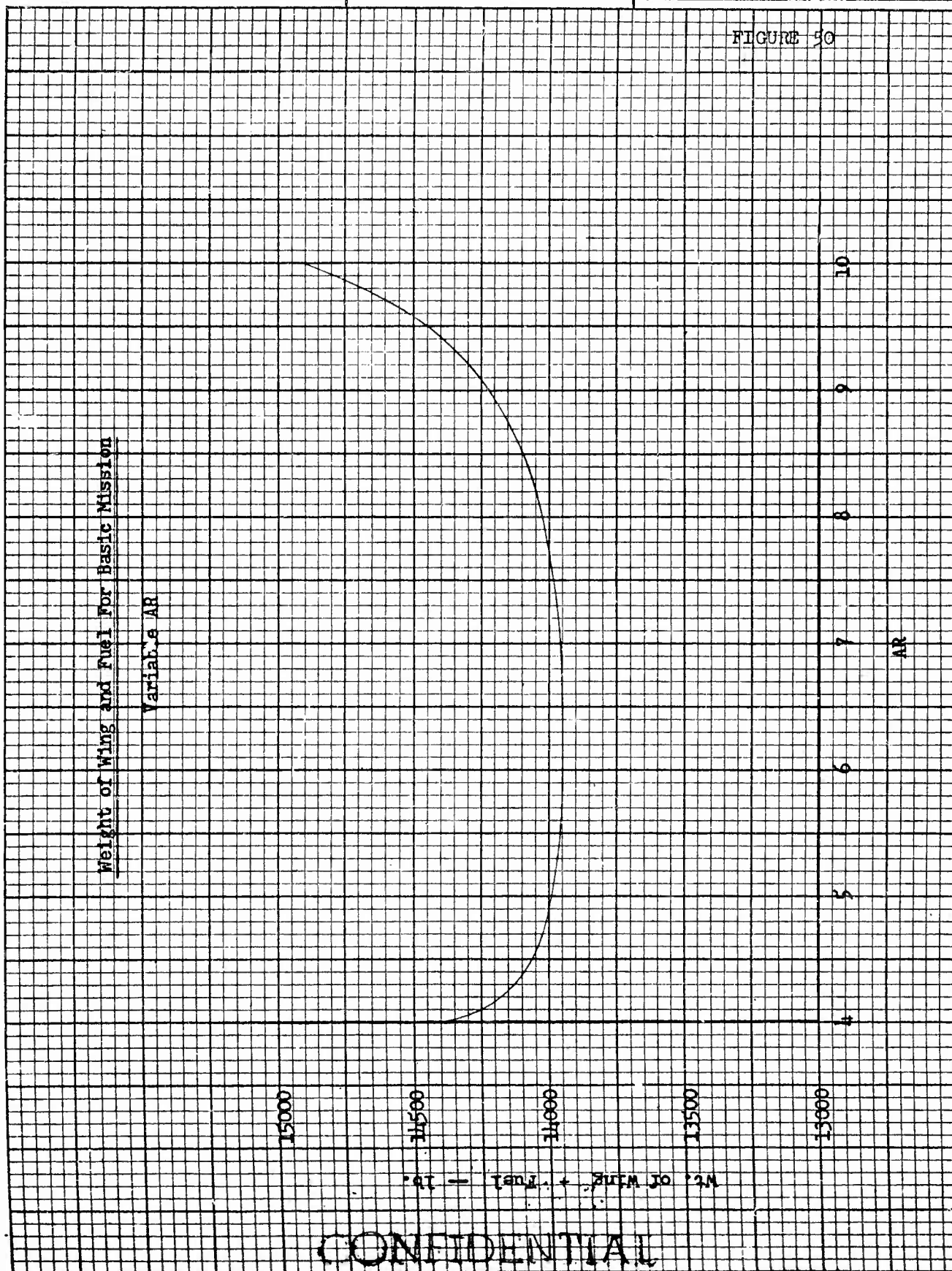

CONFIDENTIAL

FIGURE 51

13300

Performance Weight = 10,000 lb.

AR = 6.52 Two T-49 Engines

Configuration No. 1

13200

13100

13000

12900

Fuel - lb.

12800

12700

12600

12500

12400

30

40

50

60

W/B

CONFIDENTIAL

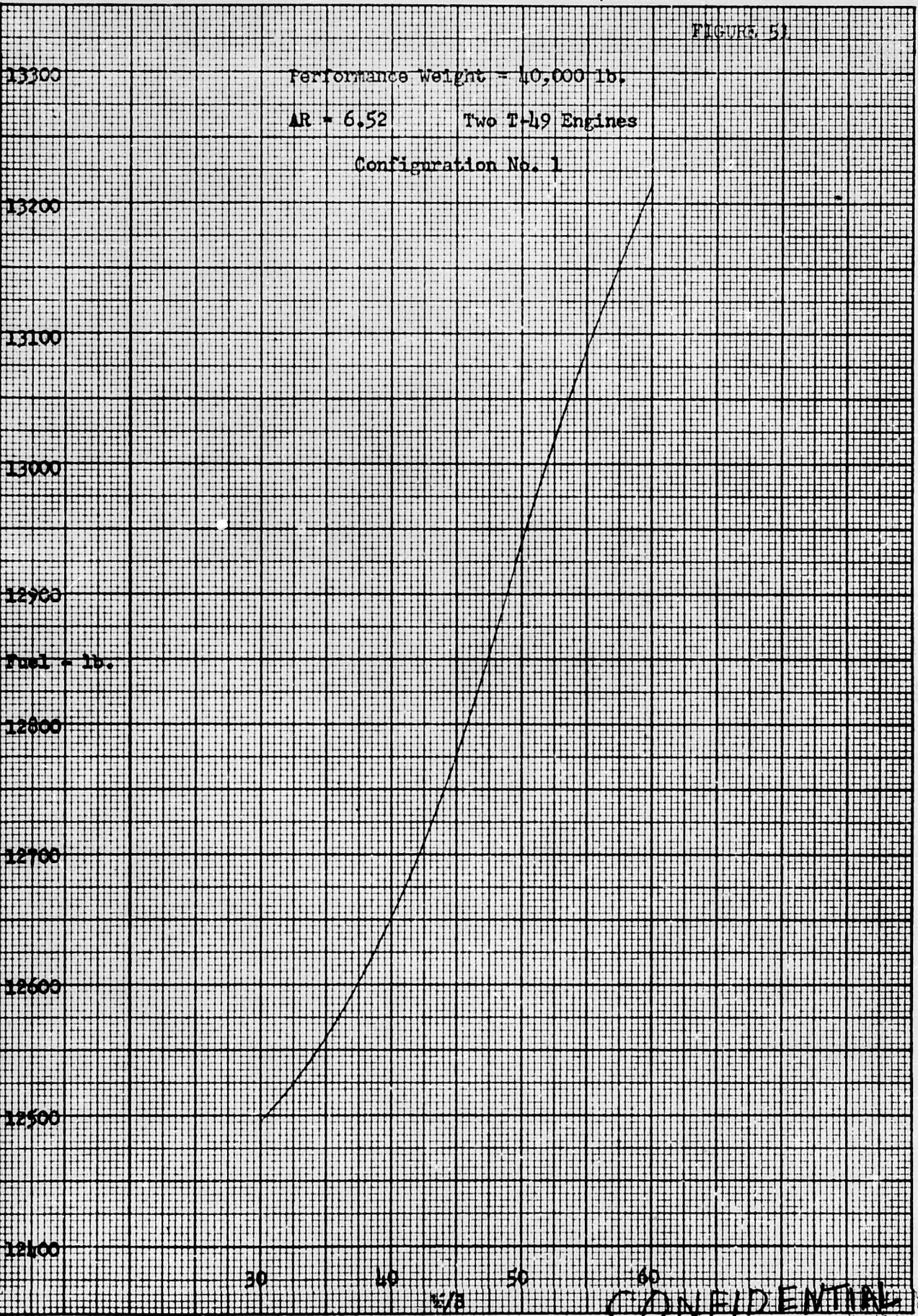

BY _____ DATE _____
CHECKED _____ DATE _____

CONFIDENTIAL
BELL Aircraft CORPORATION

MODEL _____ PAGE 04
SHIP _____ REPORT D181-945-004

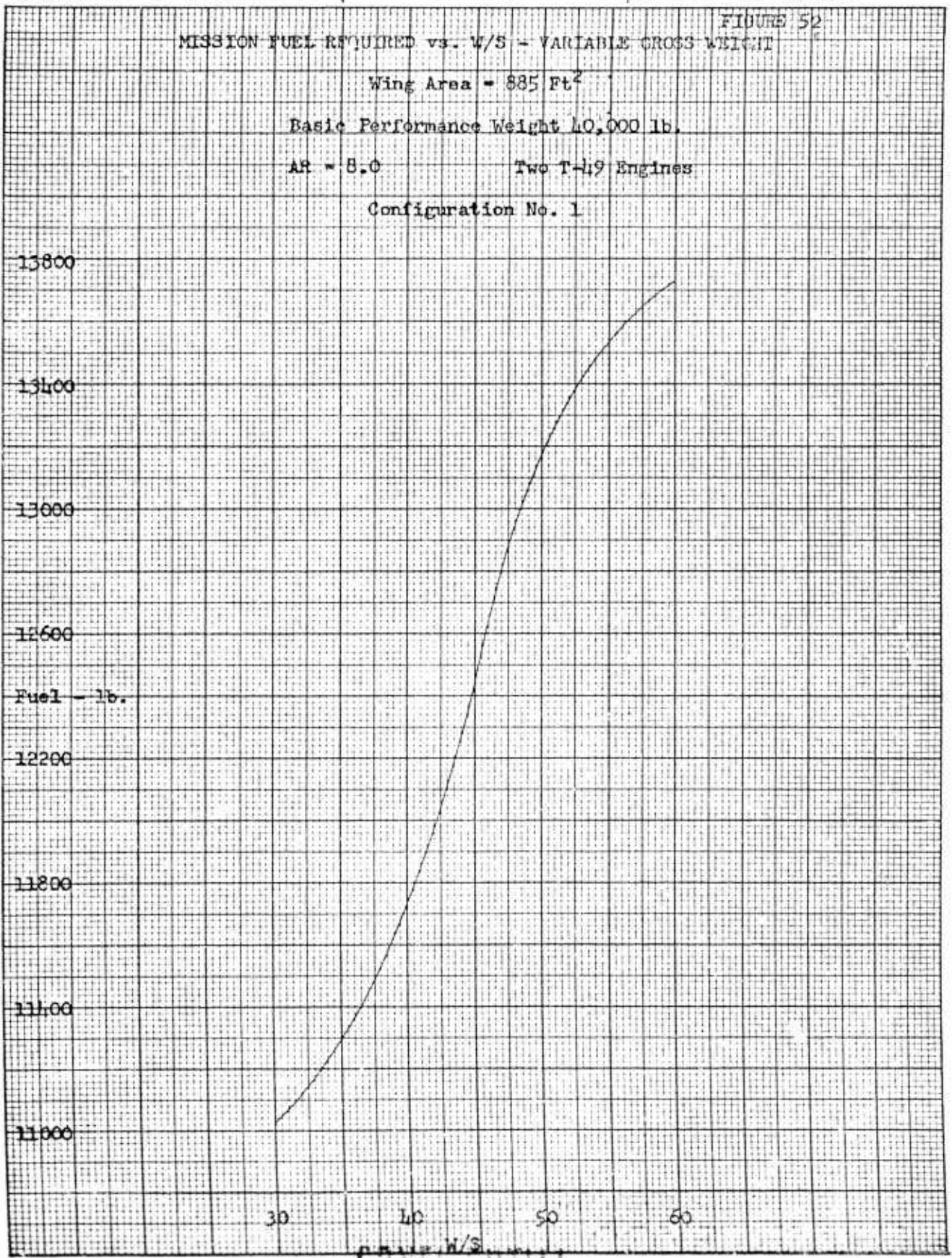

CONFIDENTIAL

FIGURE 5B

VERTICAL TAKE-OFF PERFORMANCE

T = 50,000 lb.

T49 Engine

Variable $\frac{T}{W}$

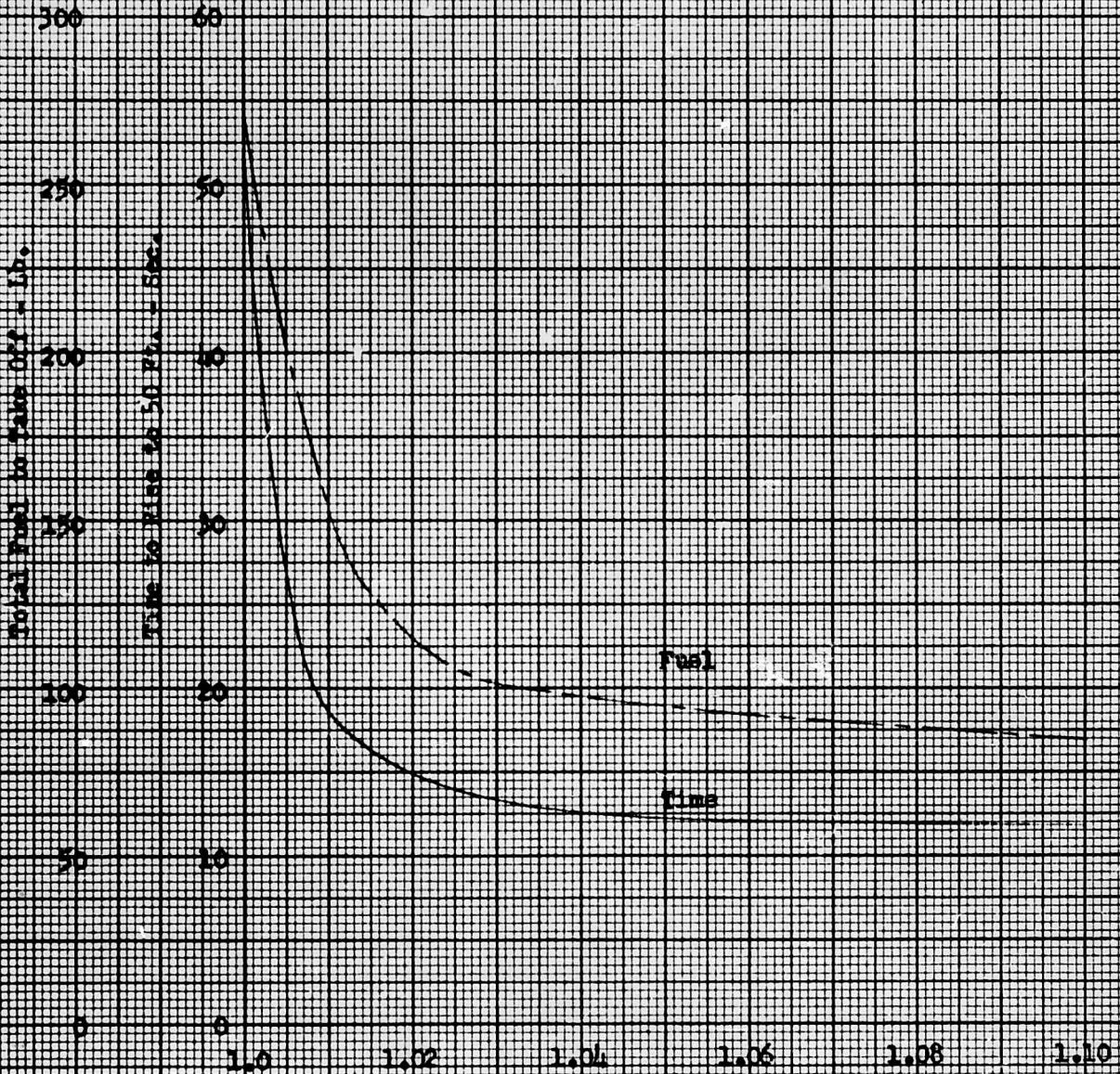

T/W

VERTICAL TAKE-OFF PERFORMANCE

FIGURE 54

T = 50,000 lb.
TL9 Engine
Variable $\frac{T}{W}$

Altitude Attained During Acceleration to 5 FT/SEC - Ft

Time to Accelerate Vertically to 5 FT/SEC - SEC

36
32
28
24
20
16
12
8
4
0

18
16
14
12
10
8
6
4
2
0

1.0 1.02 1.04 1.06 1.08 1.10

$\frac{T}{W}$

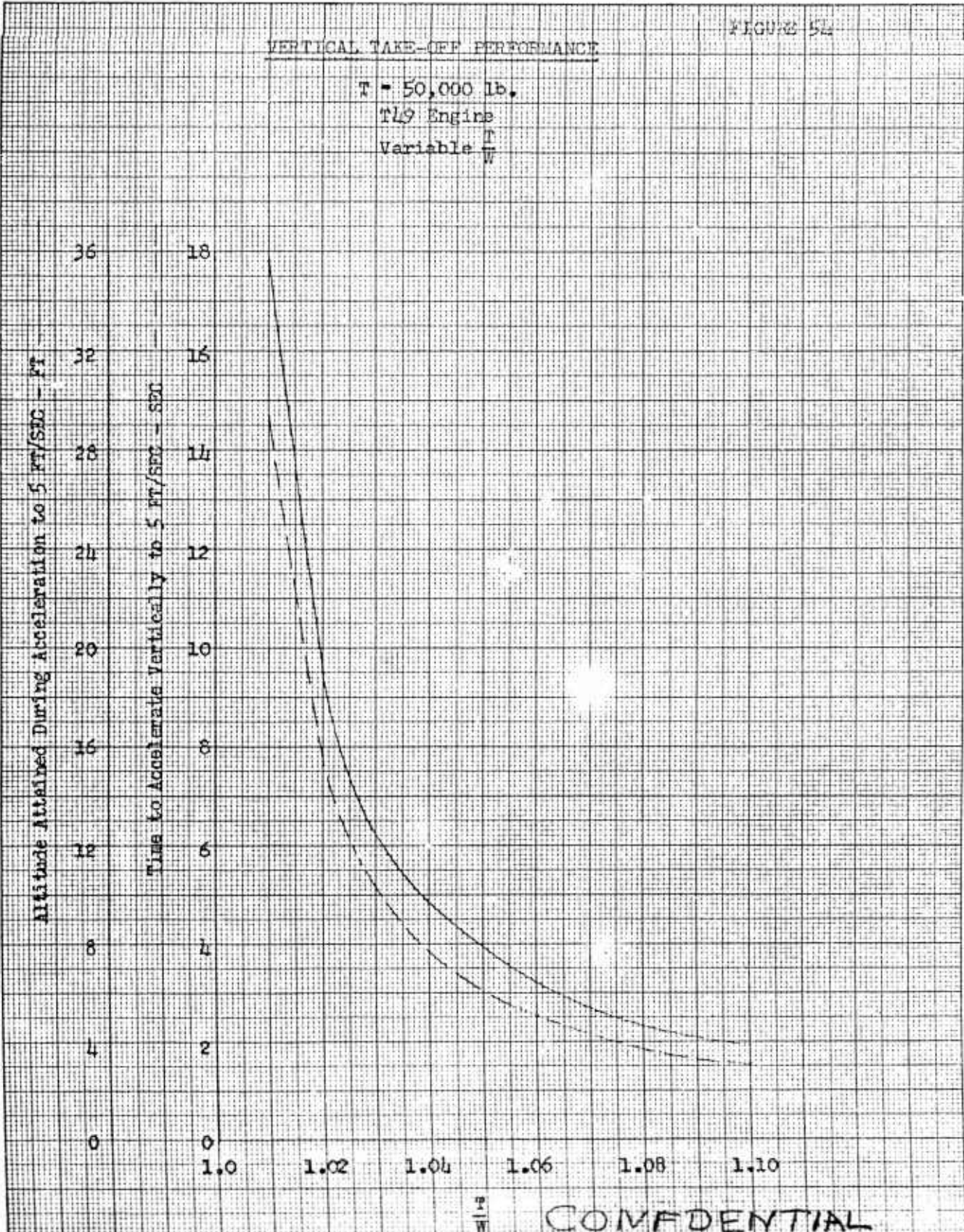
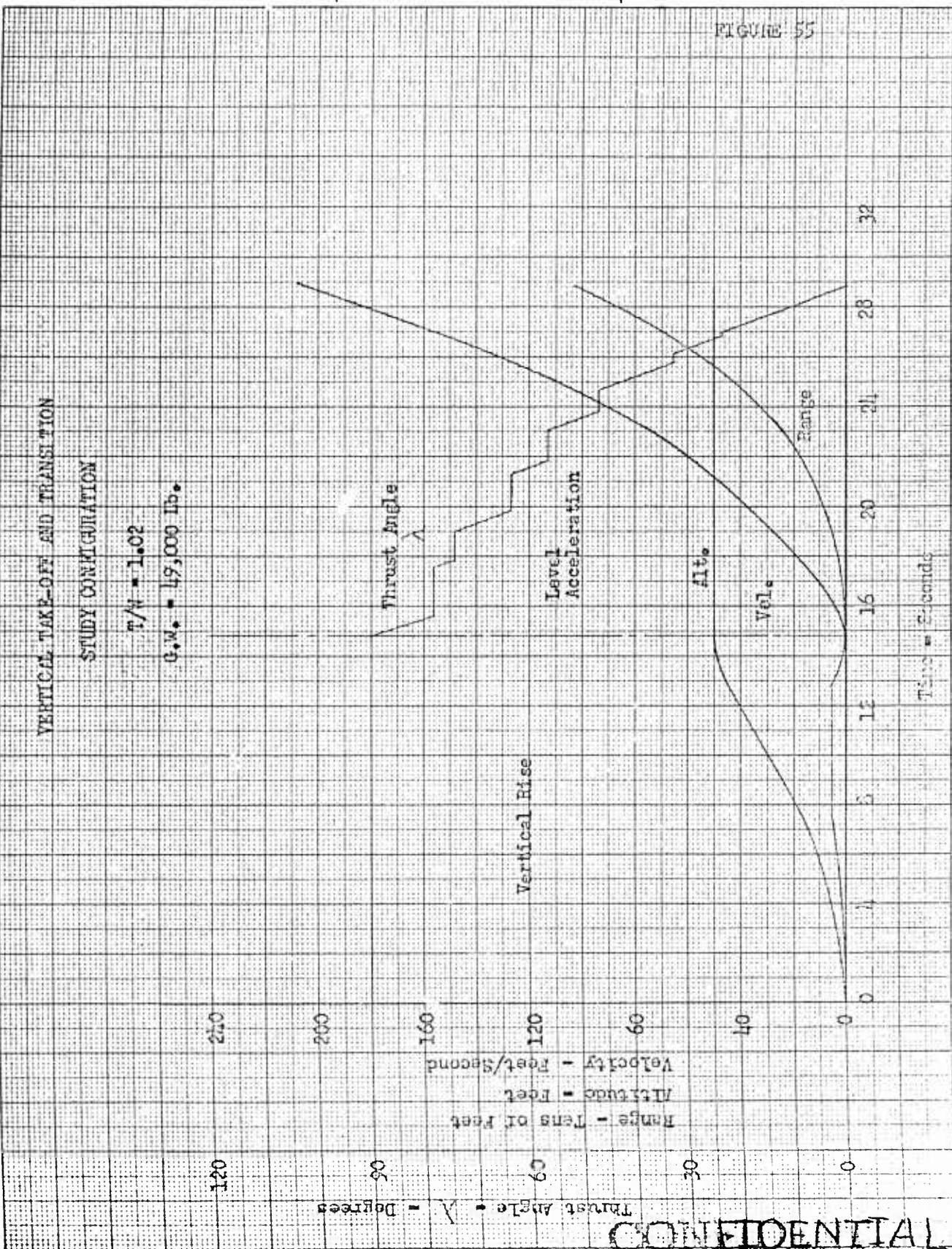

FIGURE 55



CONFIDENTIAL

III. DESCRIPTIONS OF THE SPECIFIC CONFIGURATIONS
 (D181-960-007, D181-960-009, & D181-960-011)

Three airplanes were designed two of which are similar except for the power plants and ducted propellers. They all had six engines supplying power to four ducted propellers. The engines used were the Rolls Royce RB 109 and the Allison 550-B1 gas turbines. On the two similar configurations, which were designated D181-960-007 and D181-960-009, the engines were mounted integrally with the ducts to take advantage of the residual thrust in vertical flight. In each case the wing tip ducts housed two engines each and the inboard ducts one engine each. The third configuration, D181-960-011, had the engines mounted in twin booms which extended aft to support the tail. The power, from the six Allison engines, was interconnected by a common shaft and clutch arrangement. The configurations will be referred to simply as the -007, -009, and -011. The -007 was powered by the Rolls Royce engines and the -009 by the Allisons. Figures 56, 57 and 58 are three view drawings of the -007, -009, and -011 respectively.

III.A. PHYSICAL CHARACTERISTICS

The pertinent physical dimensions and weights of the -007 and -009 are listed in Table III. All three airplanes were designed to be capable of a vertical take-off at a gross weight of 70,000 pounds at 6000 feet and 95°F while maintaining 3% thrust margin. At this gross weight, in addition to an 8000 pound pay load, the -009 could carry 15,915 pounds of fuel and the -007 could carry 13,075 pounds of fuel. The -011 had a gross weight of 74,996 pounds with 15,000 pounds of fuel and the 8000 pounds pay load. As this was

CONFIDENTIAL
BELL *Aircraft* CORPORATION

TABLE III

PHYSICAL CHARACTERISTICS

Configurations D181-960-007 & -009

Item	Units	Configurations	
		D181-960-007	D181-960-009
<u>OVERALL DIMENSIONS</u>			
Length	ft	81	81
Height	ft	33	33
Span	ft	101.1	97.7
<u>WEIGHTS</u> (for vertical T.O. at 6000 ft and 95°F with 3% thrust margin.)			
Gross Weight	lb	70,000	70,000
Fuel	lb	13,075	15,915
Pay Load	lb	8,000	8,000
Water for Power Augmentation	lb	1,300	1,300
<u>POWER PLANTS</u>			
Manufacturer and Identification		Rolls Royce RB109	Allison 550-B1
Number of Engines		6	6
S. L. Static Rated Power	SHP	4,020	5,168
S. L. Static Rated Residual Thrust	lb	1,000	830
<u>DUCTED PROPELLERS</u>			
Number of Units		4	4
Propeller Diameter Inboard	ft	10.8	8.4
Outboard	ft	15.4	11.8
Propeller Hub to Tip Ratio		.4	.5
Design Thrust/Horsepower	lb/HP	2.96	2.34

PHYSICAL CHARACTERISTICS

(continued)

Item	Units	Configurations	
		D181-960-007	D181-960-009
Fan Power Loading	HP/ft ²	49.6	117.6
Static Inlet Diameter Inboard	ft	14.1	11.1
Outboard	ft	19.8	15.0
<u>PROPELLERS</u>			
Inboard Type		single rotation	variable pitch
Number of Blades		-	12
Blade Twist	deg		23.7
Section Root			65A6.307
Tip			65A3.305
RPM			1540
Outboard Type		contra-rotating	variable pitch
Number of Blades			10
Blade Twist Front	deg		23.2
Rear	deg		17.7
Section Front Root			65A6.806.2
Tip			65A3.904.9
Rear Root			65A5.905.7
Tip			65A3.604.8
RPM			1000

CONFIDENTIAL
BELL *Aircraft* CORPORATION

PHYSICAL CHARACTERISTICS

(continued)

Item	Units	Configurations	
		D181-960-007	D181-960-009
<u>WING</u>			
Ref. Area	ft ²	1220	1220
Span	ft	85	85
Aspect Ratio		6.0	5.8
Thickness/chord	%	12	12
Section		64A412	64A412
<u>HORIZONTAL TAIL</u>			
Area	ft ²	310	310
Aspect Ratio		4.35	4.35
Thickness/chord	%	8	8
<u>VERTICAL TAIL</u>			
Area	ft ²	230	230
Aspect Ratio		1.82	1.82
Thickness/chord	%	8	8
<u>FUSELAGE</u>			
Frontal Area	ft ²	120	120
Diameter	ft	12	12
Length	ft	81	81
Fineness Ratio		6.75	6.75

overweight. The configuration was rejected and not considered further. The prime purpose of the design was to compare the two systems of power application. The use of engines in the ducts resulted in lighter weight as well as more thrust available. The -009 and -007 were 81 feet long and 33 feet high. The -009 had an over-all span of 97.7 feet, and the -007 had an over-all span of 101.1 feet. The difference in span was due to the larger ducts on the -007.

III.B. DUCTED PROPELLER CHARACTERISTICS

The ducted propeller installations were designed to provide 72,100 pounds of thrust at 6000 feet and 95°F. The duct and propeller sizes were chosen to achieve this thrust with the available power and residual thrust. The power available at 6000 feet and 95°F was augmented by water injection to the rated power under sea level static conditions. The gearing and inlet losses, which consisted of a total pressure recovery at the engine of 97% and a 2% gearing loss, amounted to about a 7% power loss. Figures 59 and 60 show the available power of the RB 109 and Allison 550-B1 engines respectively. Figures 61 and 62 show the residual thrust and fuel flow characteristics of these engines. The Rolls Royce RB 109 delivered 4020 HP under sea level static conditions and had 1000 pounds of residual thrust, while the Allison 550-B1 had 5168 HP and 830 pounds of residual thrust, (References 7 and 8).

In designing the ducted propellers a design thrust to horsepower value was determined from the design gross weight, the residual thrust, and the available power, so as to have a total thrust to weight ratio of 1.03 at 6000 feet and 95°F. This required thrust to horsepower was used in conjunction with the static momentum analysis of Reference 1 to determine the duct design. A sample composite momentum curve is shown in Figure 63.

CONFIDENTIAL
BELL *Aircraft* CORPORATION

This curve shows thrust per horsepower ($\frac{F_e}{HP}$) as a function of the duct inlet to exit area ratio ($\frac{A_e}{A_1}$) and the disc loading in terms of horsepower per square foot of inlet area ($\frac{HP}{A_1}$). This plot shows sample results of the momentum analysis under sea level standard conditions, with a bell mouth inlet pressure recovery, a 90% fan efficiency and a constant flow area from the propeller to the exit. For a desired value of ($\frac{F_e}{HP}$) a plot of ($\frac{HP}{A_1}$) vs. ($\frac{A_e}{A_1}$) is made. ($\frac{HP}{A_1}$) increases as ($\frac{A_e}{A_1}$) increases. At this point a choice of ($\frac{A_e}{A_1}$) is made which allows a realistic design of a practical flap to give this area ratio under static conditions, and which will also permit a good cruise and high speed shroud design with the flaps closed. This choice of ($\frac{A_e}{A_1}$) fixes the ($\frac{HP}{A_1}$) required. This value of ($\frac{HP}{A_1}$) in conjunction with the horsepower available determines the inlet area and the exit or propeller area. The propeller hub to tip ratio is chosen and the diameters determined. The hub to tip ratio is chosen on the basis of propeller power loading and the volumetric requirements of the hub. That is, the minimum acceptable hub to tip ratio, which increases with increasing power loading, is estimated, this value is used unless the volume necessary to house the engines, gears, controls, etc. necessitates use of a larger hub. The detail design of the propellers, guide vanes, and exit stators is explained in Reference 1. The propellers for these configurations are shown in Figures 64 through 67. Figure 64 shows an outboard duct for the -009. Two 10 bladed, variable pitch, counter rotating, propellers, powered by two Allison 550-B1 engines formed this propulsion unit. Inlet and exit stators were not used. The inboard duct is shown in Figure 65. This unit had a 12 bladed variable pitch propeller, and had exit stators to remove rotation from the exiting flow. Figures 66 and 67 show the ducts for the -007.

CONFIDENTIAL
BELL *Aircraft* CORPORATION

The design of ducted propellers is discussed in detail in Reference 1. The propellers for the -007 were not designed in detail since the design study was made to cover a range of possible propeller types over a range of power loadings. These types were variable pitch single rotation propellers, fixed pitch single rotation propellers which were controlled by variable inlet guide vanes, and variable pitch contra-rotating propellers. The single rotation propellers had exit stators to straighten the final flow. The contra-rotating propellers had no stators. This study definitely established the feasibility of the design of ducted propeller units for these configurations. The propellers called out for the -009 were chosen as part of the study and do not necessarily represent the optimum choice of type. Any of the above mentioned types could have been used. As the purpose of the study was the determination of feasibility, no attempt was made to select the specific propeller design for these configurations. It is considered that further detail design studies on the specific configuration would determine which of the several workable solutions was most practical for mechanical design and incorporation.

The inflight thrust available was also obtained from the momentum analysis. Figure 68 is a sample of the inflight momentum analysis under sea level standard conditions, with a 90% fan efficiency and a 97% duct inlet pressure recovery. The figure shows thrust per horsepower as functions of disc loading at the propeller ($\frac{HP}{A_f}$), and free stream velocity. Using the known geometry of the propeller and the available horsepower, ($\frac{HP}{A_f}$) as a function of velocity is determined. From this, ($\frac{F}{HP}$) vs. velocity is found, which in turn gives thrust vs. velocity. Specific fuel consumption in terms of thrust was determined in a similar manner. In the performance analysis these

fuel flows were increased by 5% as specified in MIL-C-5011A. The relationship between thrust and power specific is given by:

$$(\text{SFC})_F = \frac{\text{lb. of fuel}}{\text{lb. thrust} - \text{Hr.}} = \frac{(\text{SFC})_{HP}}{\frac{F_{\text{duct}} + F_{\text{residual}}}{HP}}$$

where

$(\text{SFC})_F$ is the specific fuel consumption in terms of thrust.

$(\text{SFC})_{HP}$ is the specific in terms of horsepower.

F_{duct} is the thrust of the ducted propeller.

F_{residual} is the residual thrust of the engine.

The momentum analysis presented in Reference 1 was used in this way to establish the performance of these airplanes.

III. C. AERODYNAMIC COEFFICIENTS OF THE SPECIFIC CONFIGURATION

(D181-960-007 and D181-960-009)

The lift and drag coefficients for the configurations -007 and -009 were calculated using standard Bell Aircraft methods Reference 5. Since the two airplanes were identical except for the ducts, an analysis was made for the -007 and modified to the -009. Figure 69 shows the -007 airplane drag coefficients as a function of lift coefficient and Mach number. This curve applied to the -009 by reducing the drag coefficient by 0.0022. This increment resulted from the reduction in duct sizes. The variation of lift curve slope with Mach number for both airplanes is shown in Figure 70. The maximum lift coefficient at low speed was estimated to be 1.005 at an angle of attack of about 12 degrees.

An analysis of duct drag was made to determine the influence of duct size and shape. The drag analysis, power on, treated the flow in two parts. The flow entering the duct effected the propeller efficiency and influenced the available thrust, while the external flow contributed to the airplane drag. In the analysis, a comparison of the drag of a static and a high speed inlet was made. The static inlet was designed to have a larger inlet area in comparison with the propeller area while the inlet area of the high speed shroud was comparatively small. As a result the high speed shroud profile had thickness ratios on the order of 1/10 those of the static shroud. In each case the inlet lip design was such that no separation occurred on the upper surface of the lip. A comparison of the drag coefficient of these two types of shroud as a function of the shroud length to diameter ratio is shown in Figure 71. The drag coefficient was defined as $C_D = \frac{D}{q d^2}$

where D is the drag

q is the dynamic pressure

d is the duct diameter at the propeller.

Two different scales of C_D were used because the drags of the two types of shroud differed so widely. The drag coefficient of the static shroud was about 6 1/2 times that of the high speed shroud. Figure 72 shows the variation of drag with velocity for high speed and static shrouds with diameters of 5, 10 and 15 feet. This drag analysis clearly indicates the desirability of variable area inlets for static and high speed flight.

III . D. LEVEL FLIGHT PERFORMANCE

The classical performance of configuration -007 and -009 is shown in Figures 73 through 76 . Figures 73 and 74 are typical thrust and drag curves for gross weight of 50,000 and 80,000 pound at altitude of 0, 20,000 and 40,000 feet. These curves present the basic performance from which the classical performance stems. The maximum speed is shown by the intersection of thrust and drag curves. The excess thrust at the speeds below maximum indicates the airplanes potential for maneuver and climb. The classical performance curves showing maximum speed, climb speed, rate of climb, and time to climb as functions of altitude, are presented in Figures 75 and 76 for four gross weights of the -009 and -007 respectively. The -009 had a high speed in excess of 400 mph at all altitudes with a top speed of 527 mph at 35,000 feet. The -007 on the other hand had less high speed potential having a best speed of only 390 mph between 25,000 and 30,000 feet. This lower speed resulted from two effects; the higher drag of the larger ducts, which coupled with less forward flight thrust, to give a lower maximum speed. These effects also resulted in better rates of climb, ceilings, and shorter times to climb for the -009. At a gross weight of 60,000 pounds the sea level rates of climb were 10,700 feet per minute for the -009 and 7,450 feet per minute for the -007. A comparison of the service ceilings, at this weight, (altitude for 100 ft. per min. rate of climb) shows an altitude of 51,100 feet for the -009 and 42,000 feet for the -007. The times to climb to 20,000 feet at this gross weight were 2.1 minutes for the -009 and 3.5 minutes for the -007, and to 30,000 feet were 3.6 minutes for the -009 and 6.5 minutes for the -007.

The maximum speed of 527 mph shown for the -009 is a theoretical potential based on the thrust as calculated in the momentum analysis. At this forward speed the flow in the ducts is transonic and the relative velocity over the blades is supersonic. While these conditions are not prohibitive they do require further study and experimental investigations. A detailed investigation of transonic and supersonic flow in the blades was not made since it was beyond the scope of the basic feasibility study and there was not enough time for investigation of this phenomenon. A speed of 460 mph is attainable before transonic flow effects begin in the duct and over the rotor. A study of the propeller operating characteristics under transonic and supersonic conditions would determine the type of design necessary to attain the theoretical high speed with a practical ducted propeller propulsion system.

III.E. RADIUS AND RANGE COMPARISON (D181-960-007 and -009)

The performance analysis of the -007 and -009 airplanes considered a spectrum of radius and range missions to fully explore the available potential with both vertical and short rolling take-offs. The basic flight plan of all the radius missions was quite similar to the basic mission. The basic mission required a radius of 425 miles with an initial vertical take-off. An 8000 pound payload was carried out and 4000 pounds back. This mission was accomplished according to the following general flight plan:

1. Take-off at 6000 feet and 95°F - Vertical or short take-off depending on the initial loading. All of the landings and subsequent take-offs were vertical. Pay load out is 8000 pounds or greater.
2. Climb to cruise altitude and fly 80% of the radius.

3. Descend to sea level and fly the remaining 20%.
4. Land vertically at 6000 feet and 95°F. Exchange outgoing payload for 4000 pound return load. No fuel is added at the radius point.
5. Take-off vertically at 6000 feet and 95°F.
6. Return leg same as outgoing leg. First 20% at sea level, climb to cruise altitude for remaining 80%.
7. Land vertically at 6000 feet and 95°F holding a 10% total fuel reserve.

On all the range and radius calculations the installed fuel flow was increased 5% as specified in MIL-C-5011A. The mission comparisons are shown in Table IV.

The following missions were calculated according to the above flight plan with variations noted as they occur. The first group of missions had an initial vertical take-off. Both airplanes were capable of a vertical take-off at a gross weight of 70,000 pounds at 6000 feet and 95°F with a 3% thrust margin. This was considered the maximum vertical take-off weight. For the basic mission the -009 had a take-off weight of 67,380 pounds and carried 13,290 pounds of fuel; the -007 took off at 70,000 pounds and carried 13,075 pounds of fuel. Because of its larger ducts the -007 was heavier and capable of performing the basic mission at its maximum vertical take-off gross weight. For the basic mission the -009 cruised out at 24,800 feet and back at 29,000 feet for the altitude portion of the cruise. The -007 accomplished the altitude part of the cruise at 24,800 feet out and 28,800 feet back. These were the lowest altitudes at which the speed for long range cruise as defined

TABLE IV

	TAKE OFF G.W. #	TAKE OFF GROUND ROLL Ft	PAY-LOAD #	RADIUS MI	CRUISE ALT. Ft		CRUISE VEL. OUT MPH	CRUISE VEL. BACK MPH	CRUISE VEL. AT S.I. OUT & BACK MPH	TOTAL FUEL #
					OUT	BACK				
Basic Mission - Minimum G.W.	70000	0	8000	425	24800	28800	300	300	300	13075
	67380	0	8000	425	24800	29000	300	300	300	13290
Basic Mission - Radius at Altitude No Sea Level	70000	0	8000	508	3730	40200	368	363	-	13075
	67380	0	8000	508	42200	44500	400	376	-	13290
Maximum Payload for 425 Mile Radius	76530	280	14200	425	24000	28800	300	300	300	13390
	76890	300	16720	425	23000	28600	300	300	300	14080
Maximum Radius with 8000 # Payload	82693	610	8000	831	20000	27000	300	300	300	25768
	86150	770	8000	987	21200	26700	300	300	300	32060

NOTE: Alt = 6000 Ft.; T = 95° F; Fuel Reserve = 10% Total Fuel; Payload Back = 4000 #.
 Initial take-offs are listed.
 Remaining take-offs and landings are vertical.

RADIUS COMPARISON OF D181-960-007 & -009

in MIL-C-5011A was 300 mph. Various extensions and modifications of the basic mission were possible by utilizing a vertical take-off capability at a 70,000 pound gross weight. By increasing the fuel of the -009 to a total of 15,920 pounds, the radius could be increased to 513 miles. Holding the 425 mile radius with a 70,000 pound take-off, the cruise altitude, for the altitude portion, could be reduced to 11,300 feet. Still using the 70,000 pound gross weight the cruise velocity for the altitude portion of the cruise could be increased to 420 mph while maintaining 300 mph at sea level. A radius of 302 miles was possible with a cruise velocity of 455 mph at altitude and sea level. These missions are presented in more detail in Section I.

The characteristics of the airplane permitted the use of a short take-off similar to the STOL type of airplanes. In order to evaluate the resulting potential, a group of missions involving an initial rolling take-off were calculated. All landings and subsequent take-offs were vertical. The basic flight plan with 20% of the distance at sea level was followed. The first mission held the 8000 pound payload and increased the fuel so that the gross weight for the vertical landing would be 70,000 pounds. The -009 had a radius of 987 miles and initial take-off ground roll of 770 feet with a take-off gross weight of 86,150 pounds. The -007 had a radius of 831 miles after an initial take-off run of 610 feet at a gross weight of 83,690 pounds. Under the above conditions the airplane could fly the basic 425 mile radius and carry an increased payload. The -009 could carry 16,720 pounds out and the -007 could carry 14,220 pounds out. Both airplanes returned with a 4000 pound payload.

The one way range capability of these airplanes is shown in Figures 77 and 78. The ferry range with an 8000 pound payload was investigated with initial vertical take-off and with 400 foot and 800 foot ground roll take-offs. At the low altitudes the velocity for long range cruise was less than 300 mph while at the higher altitudes it was greater. A minimum cruise velocity of 300 mph was used in these calculations. The range for both configurations increases steadily with increase in altitude, reaching an altitude where the velocity for long range becomes equal to 300 mph. From that point on the range increase with altitude is smaller.

For a VTO capability at a gross weight of 70,000 pounds the -009 can attain a maximum range of 1370 miles at an altitude of 40,000 feet. For the same gross weight and VTO, the -007 has a maximum range of 1080 miles at an altitude of 35,000 feet. Taking-off with an initial ground roll of 400 feet at a gross weight of 78,460 pounds, the maximum range of the -009 increased to 2010 miles at the 40,000 foot altitude while the -007 had a maximum range of 1695 miles at 35,000 ft. Using an 800 foot ground roll at a gross weight of 86,760 pounds, the maximum range was increased to 2540 miles for the -009 with the cruise altitude remaining at 40,000 feet. The maximum range for the -007 was 2155 miles; the cruise altitude drops from 35,000 feet to 30,000 feet.

Figure 78 shows the variation of range with speed at a constant altitude of 30,000 feet. The vertical portions of these curves are a result of the limitation imposed on the speed for long range operation; specification MIL-C-5011A defines this speed as the greater of the two speeds at which 99 percent of the maximum miles per pound of fuel is

CONFIDENTIAL
BELL *Aircraft* CORPORATION

attainable. For vertical take-off at a gross weight of 70,000 pounds the -009 had a maximum range of 1361 miles for velocities ranging from 265 miles per hour to 320 miles per hour. From the above definition the 320 mph is the velocity for long range cruise. The -007 has a velocity range from 272 miles per hour to 303 miles per hour for a maximum range of 1115 miles. For a 400 foot ground roll at a gross weight 78,460 pounds, the maximum range for the -009 and the -007 is increased to 1855 miles and 1610 miles respectively. The -007 velocity range was from 270 miles per hour to 317 mph while the -009 had a velocity range varying from 276 miles per hour to 311 miles per hour. Using an 800 ft. ground roll at a corresponding gross weight of 86,760 pounds, the maximum range increased to 2520 miles for the -009 and 2230 miles for the 007. The velocity increments remained the same as the ones for the previous gross weight.

An increase in speed above that for long range cruise results in a small range decrease for both configurations. This small range variation with increased speed allows the airplane to perform special high speed missions without undue penalty.

A payload of 8000 pounds was carried in all of the ferry ranges mentioned. The maximum ferry ranges that were attained by changing the total pay load into a fuel load are shown in Figures 77 and 78. Using an 800 foot ground roll at a gross weight of 86,760 pounds, Figure 77 shows a maximum range of 3265 miles for the -009 at an altitude of 40,000 feet. At the same take-off condition but at 30,000 feet, Figure 78 shows a maximum ferry range of 3340 miles for the -009. The velocity range was from 276 miles per hour to 311 miles per hour.

CONFIGURATION - D181-960-007

FIGURE 56

CONFIDENTIAL

6 Rolls Royce
RB 109 Engines

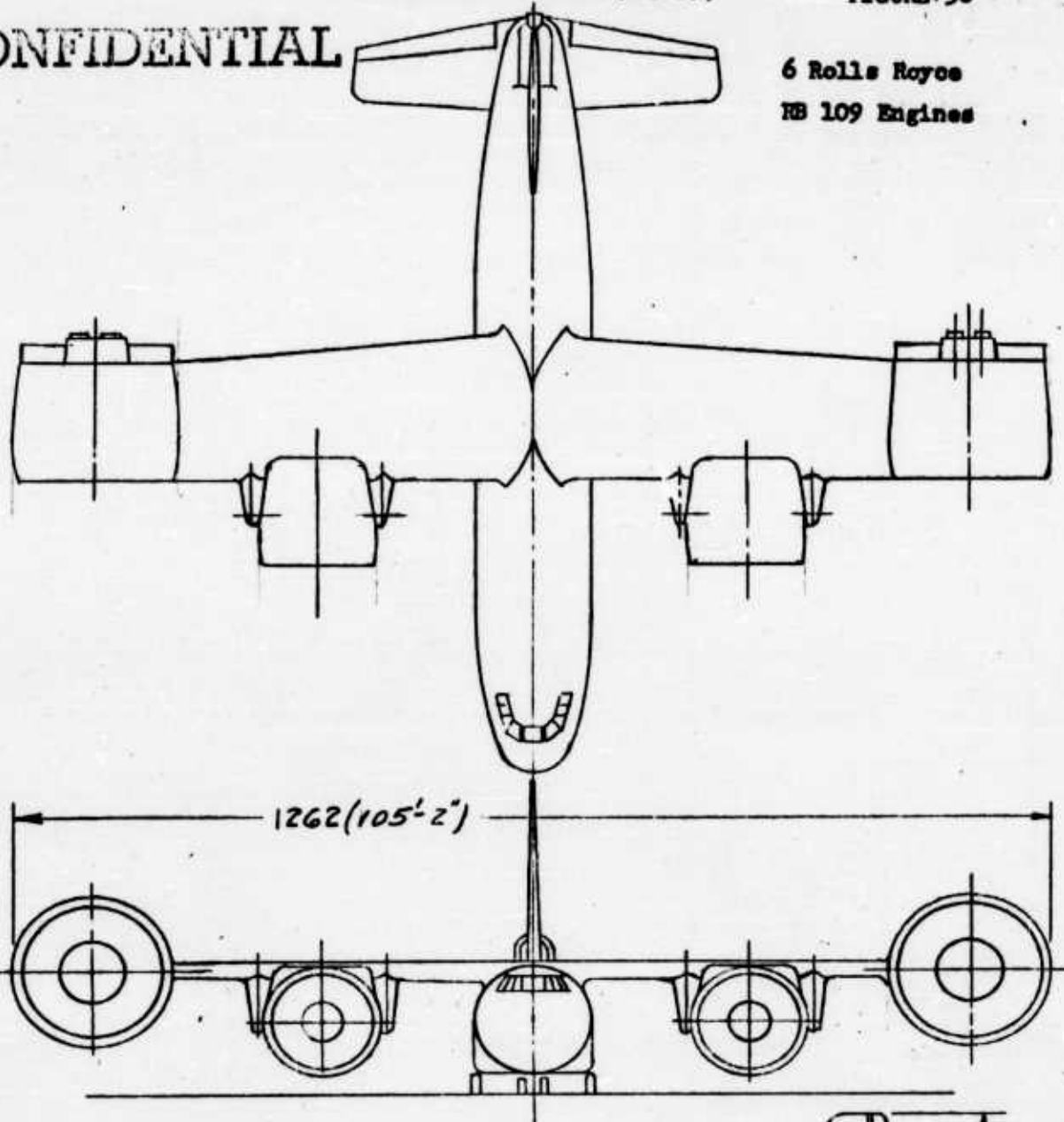

CONFIDENTIAL

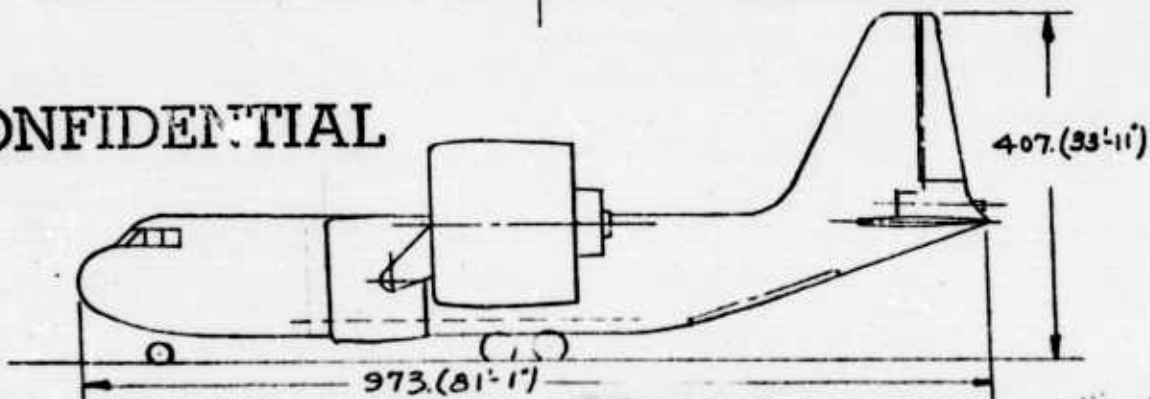

1/200
SCALE

Form 84-1 Rev. 353

CONFIGURATION - D181-960-009

FIGURE 57

CONFIDENTIAL

6 Allison 550-B-1 Engines

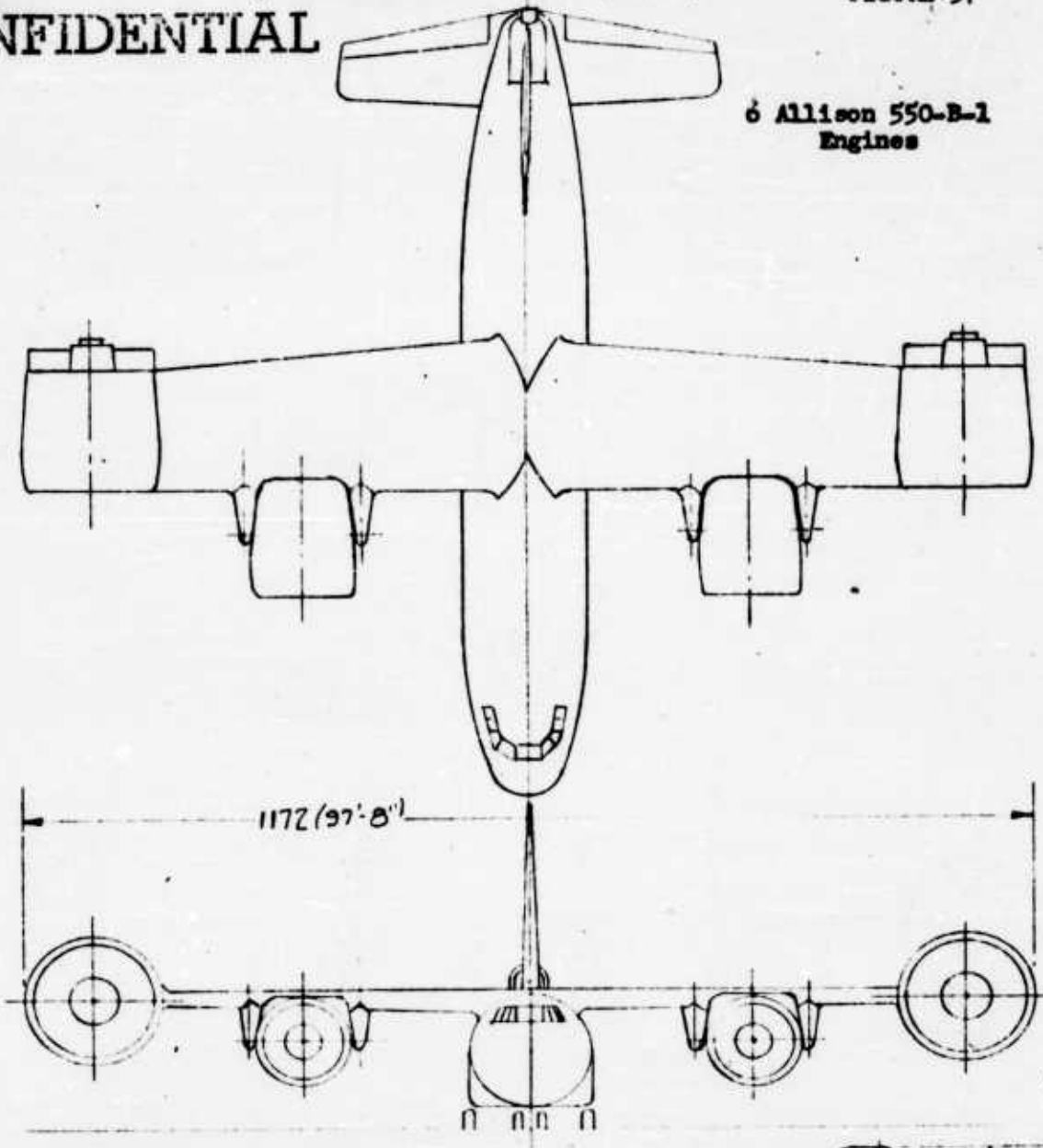

CONFIDENTIAL

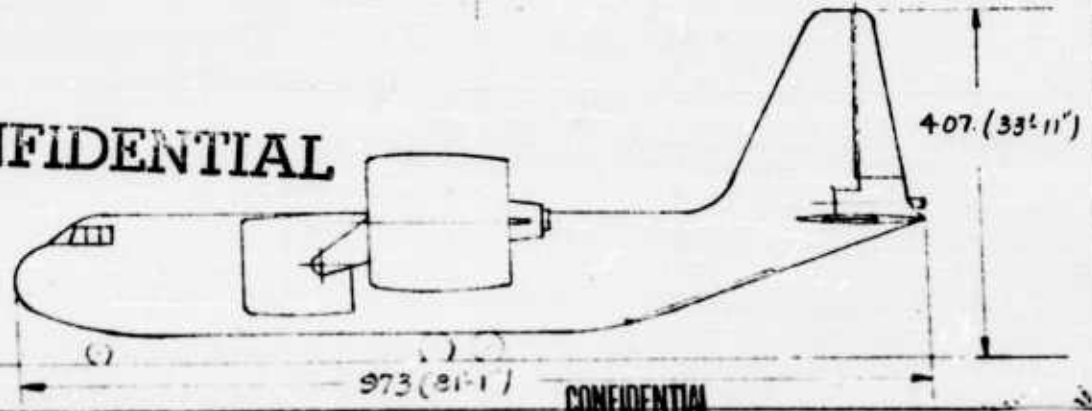

CONFIDENTIAL

1/200
SCALE

Form E-1 Rev. 30

CONFIDENTIAL

FIGURE 58

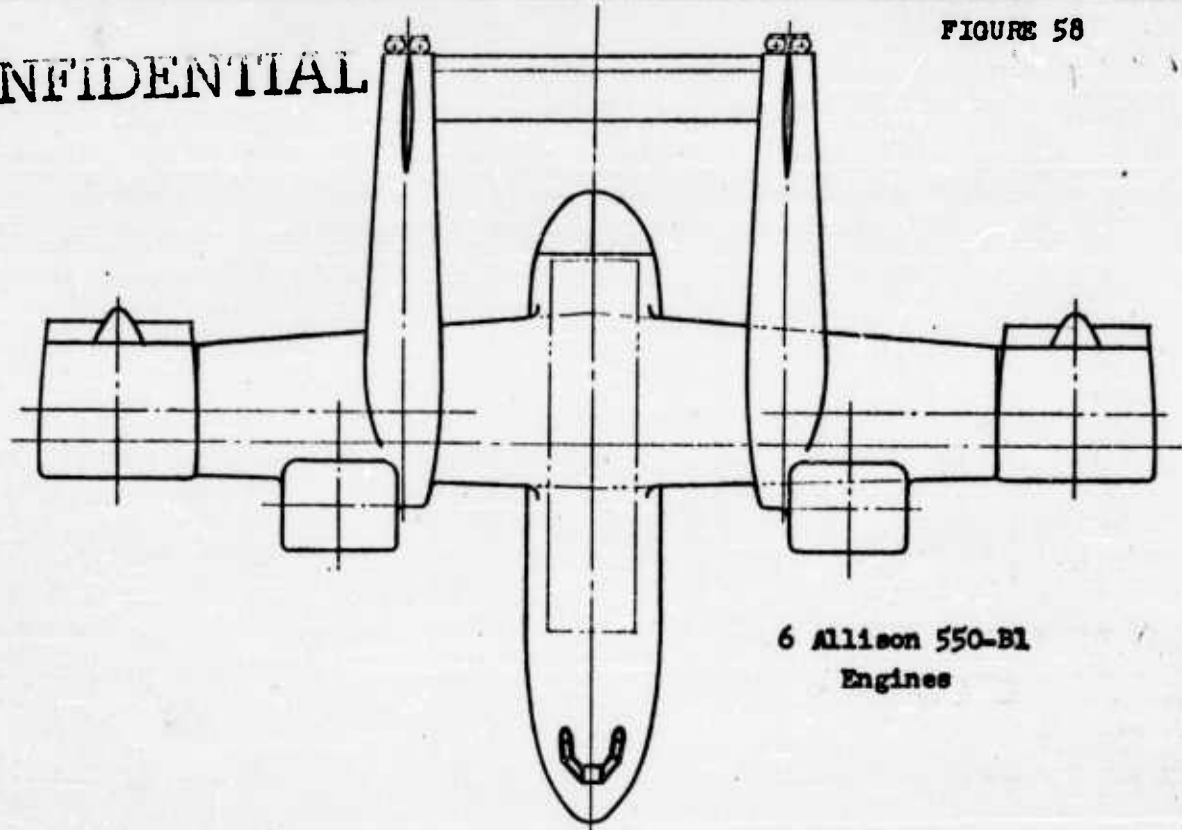

6 Allison 550-B1
Engines

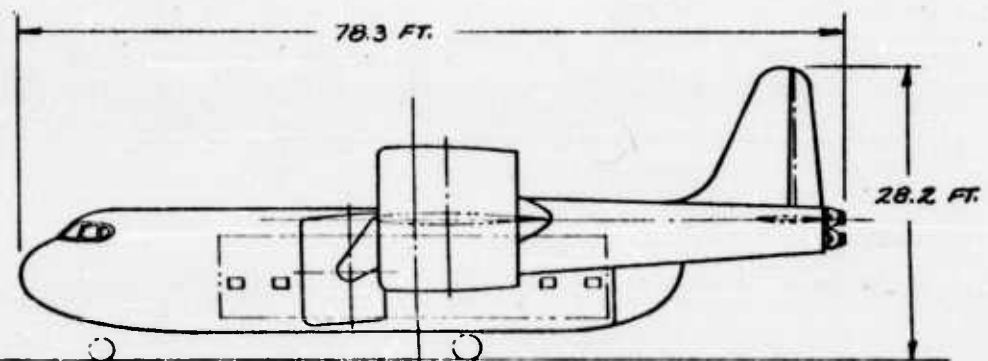
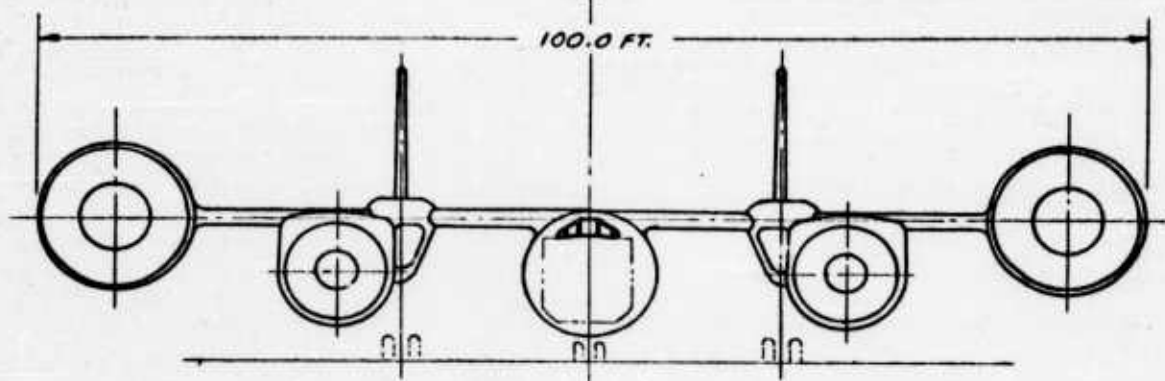

Para E-1 Rev. 303

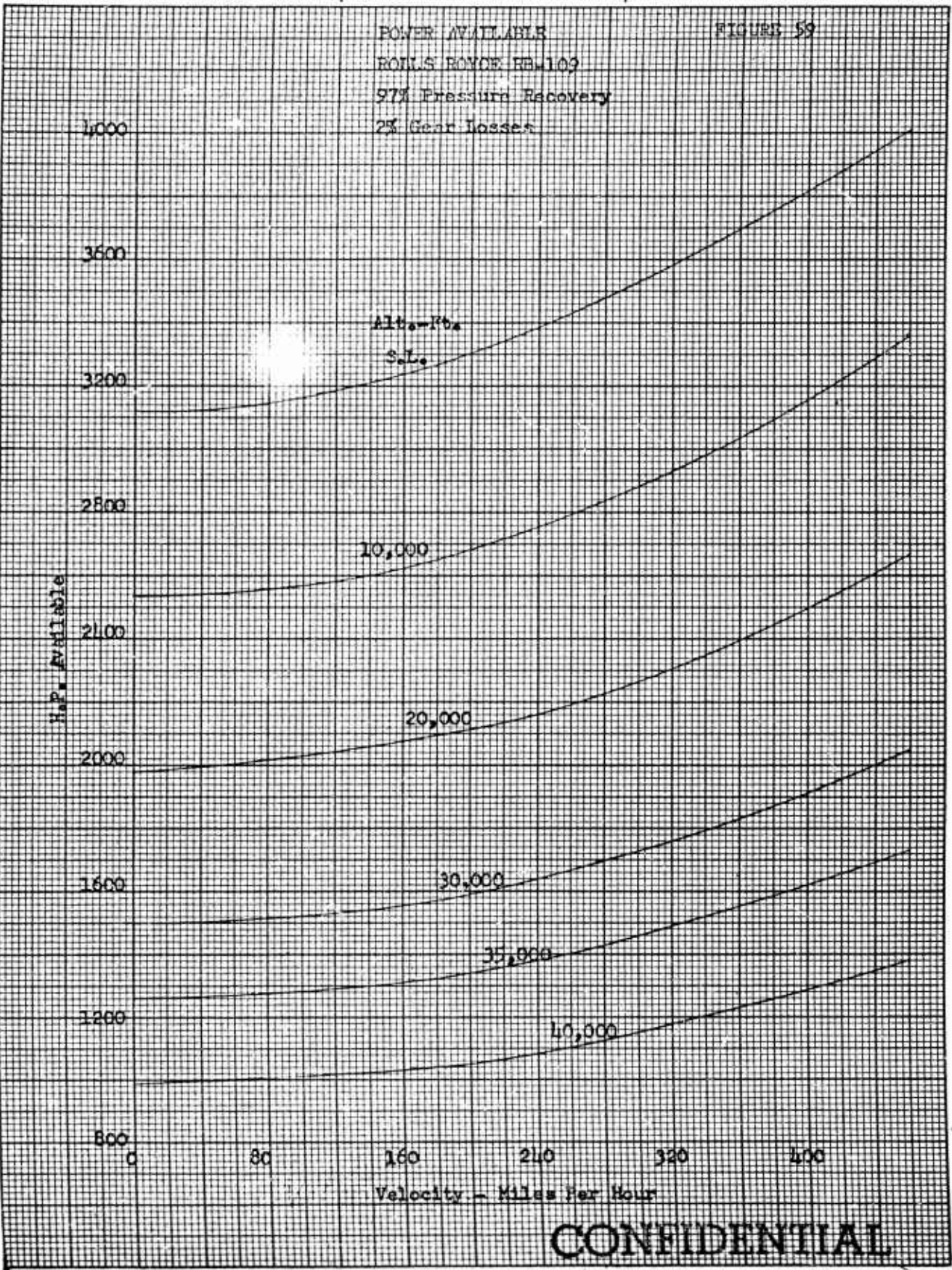

CONFIDENTIAL

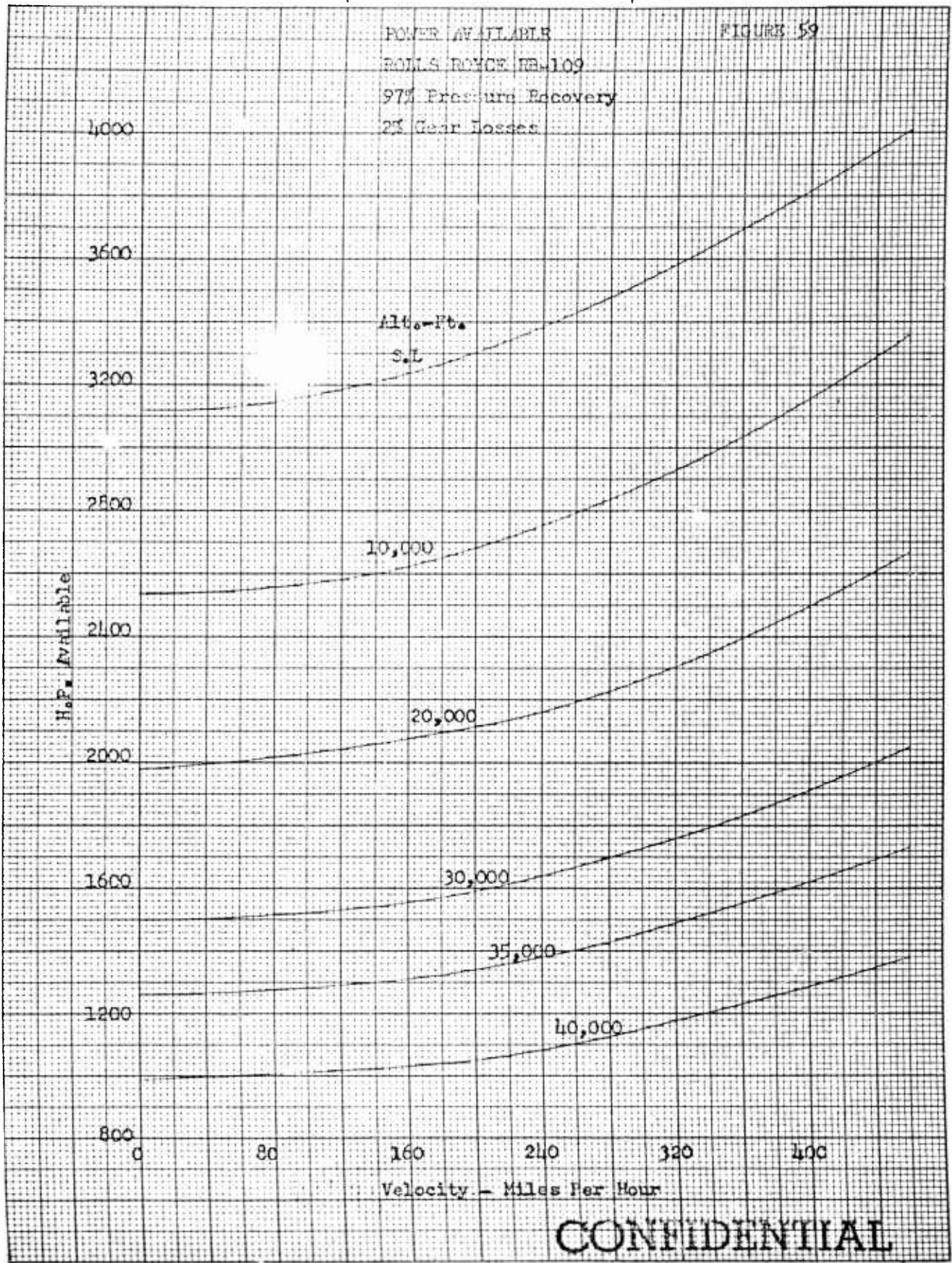

CONFIDENTIAL

FIGURE 60

POWER AVAILABLE
ALLISON 550-B1
97% Pressure Recovery
2% Gear Losses

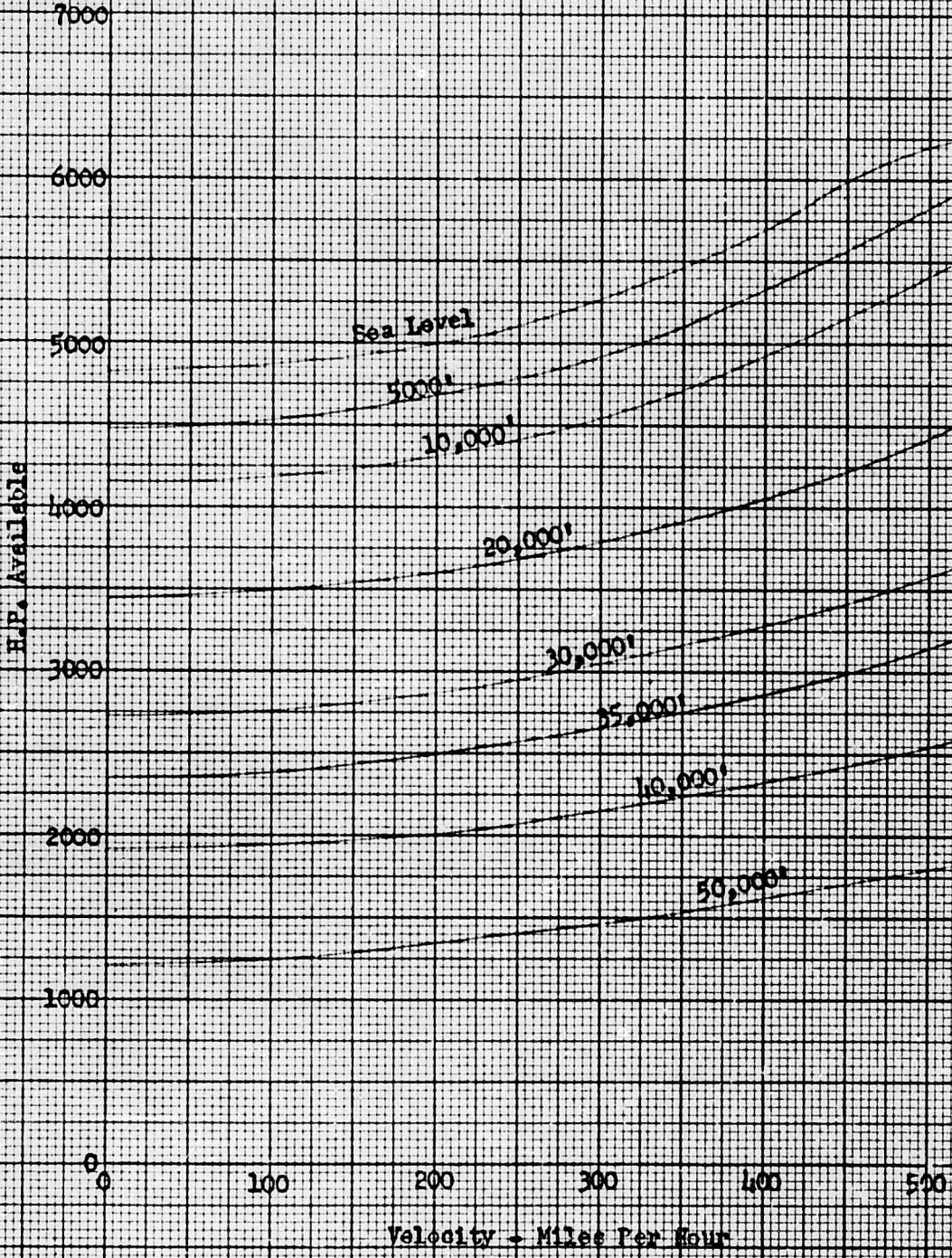

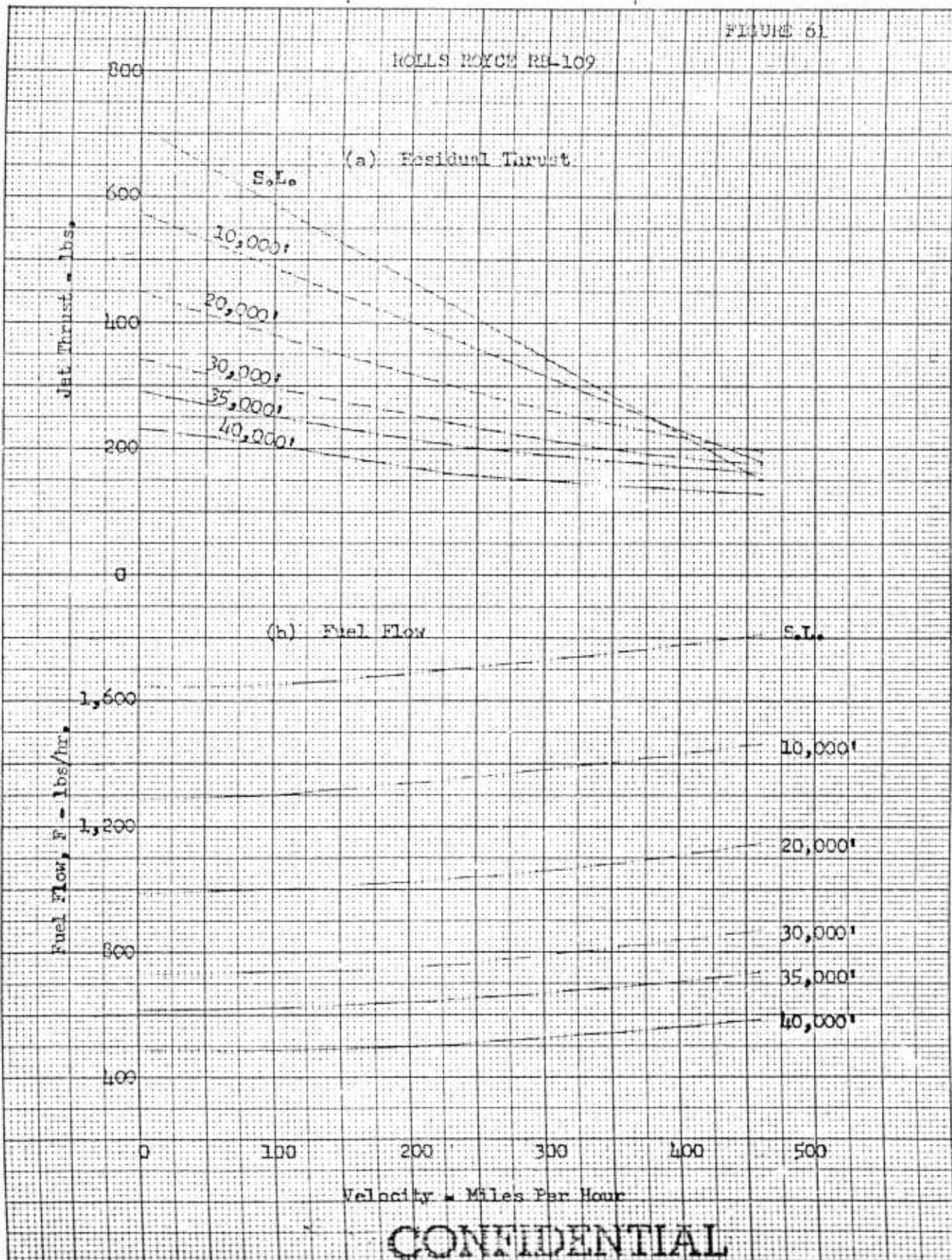
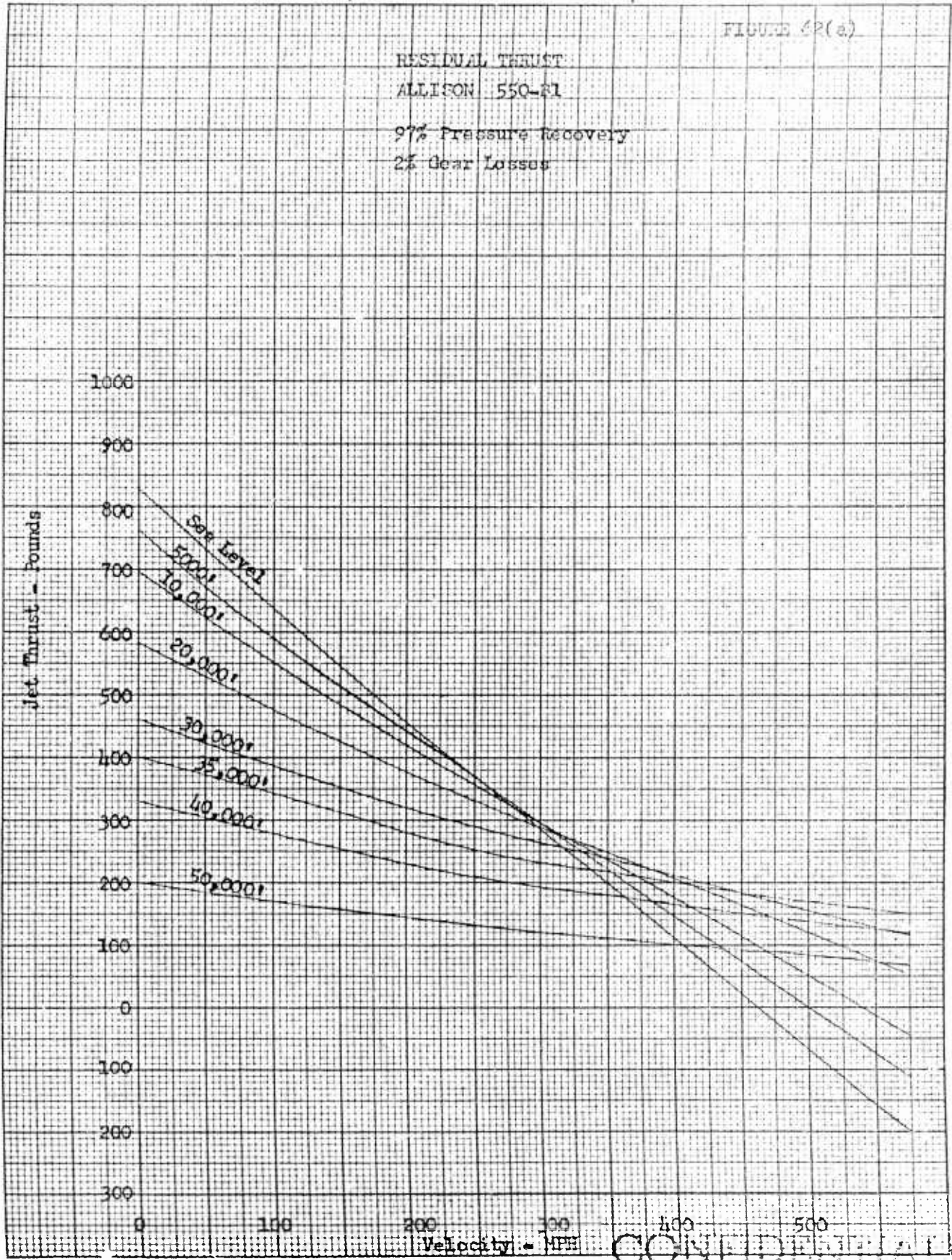

FIGURE 62(a)

RESIDUAL THRUST
ALLISON 550-R1
97% Pressure Recovery
2% Gear Losses



CONFIDENTIAL

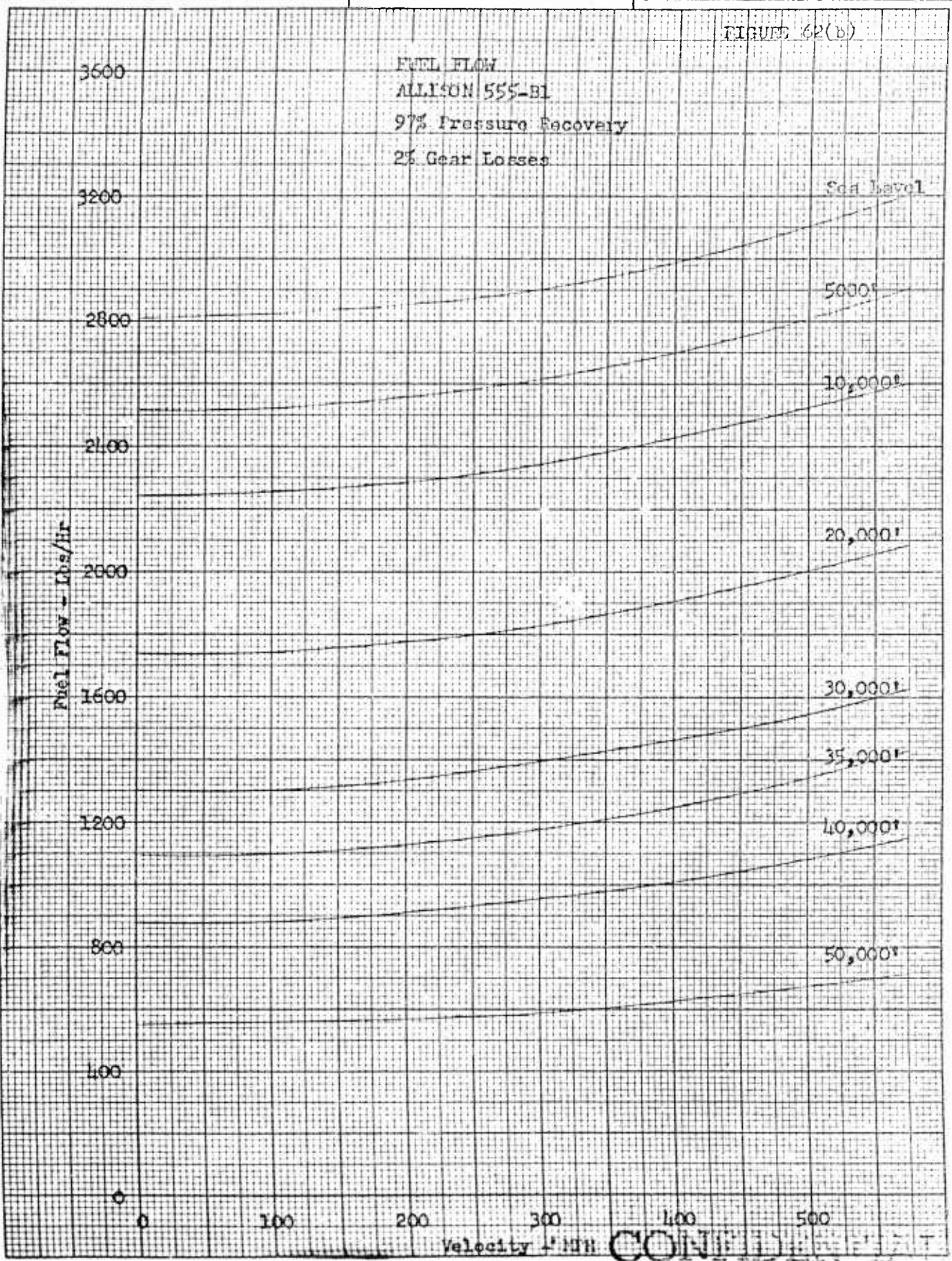

FIGURE 68

DICTED PAN PERFORMANCE - STATIC

$$\frac{V_e}{HP} = f \left(\frac{HP}{A_1}, \frac{A_2}{A_1} \right)$$

$\gamma = .19$

Sea Level Standard

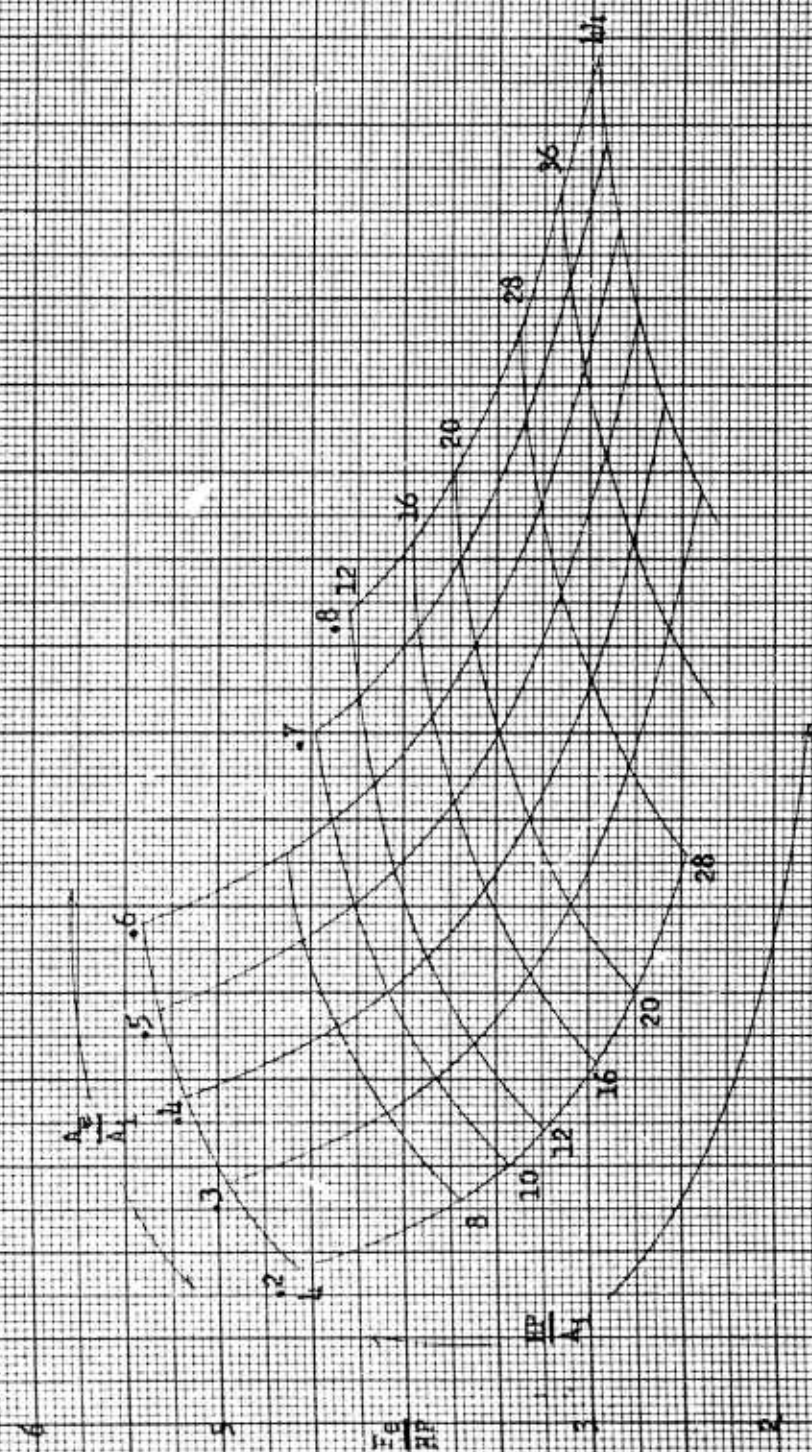

CONFIDENTIAL

FIGURE 64

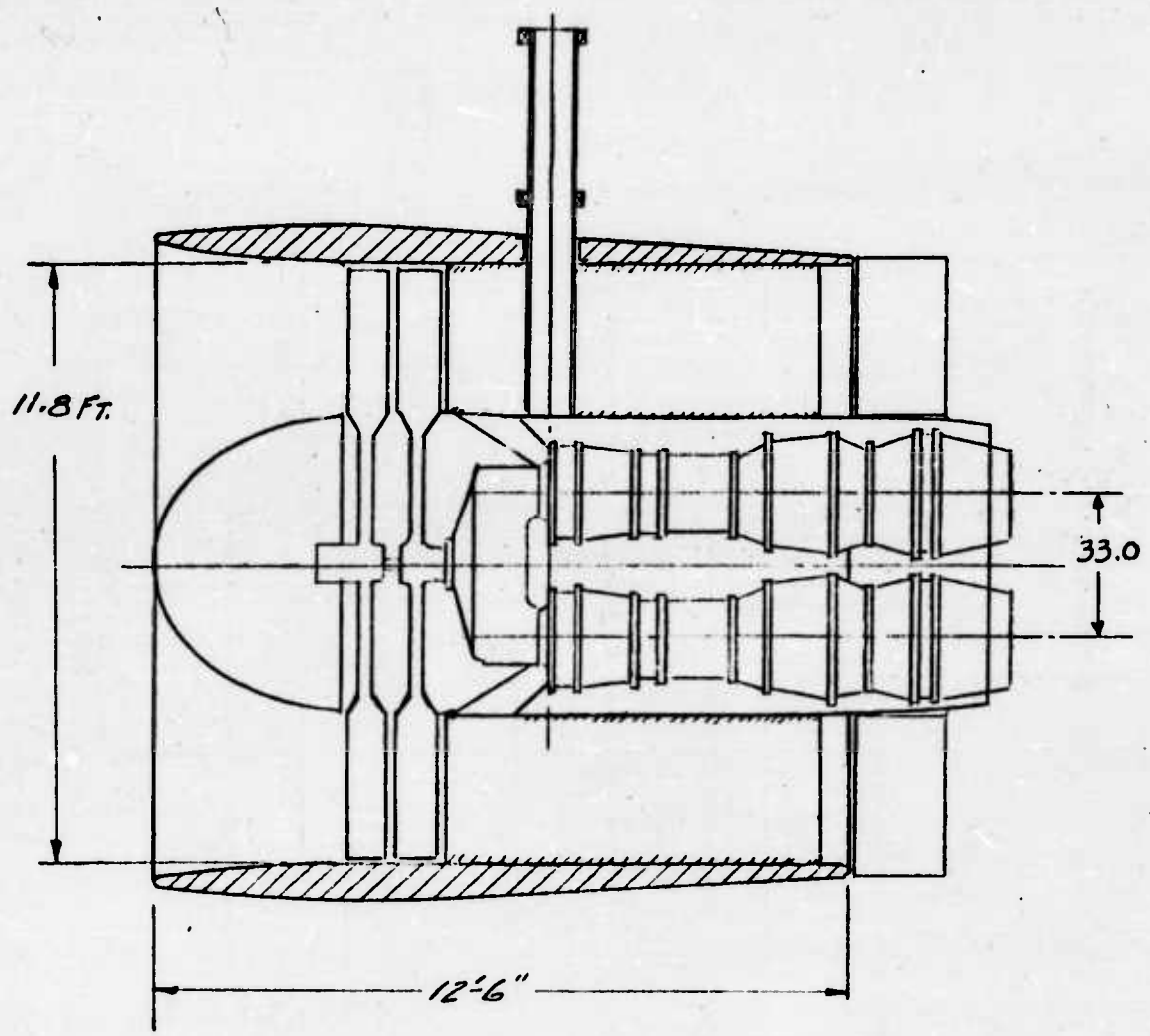

PLAN VIEW

Form E4-1 Rev. 353

OUTBOARD DUCT - D181-960-009

Allison 550-B1

CONFIDENTIAL

CONFIDENTIAL

FIGURE 65

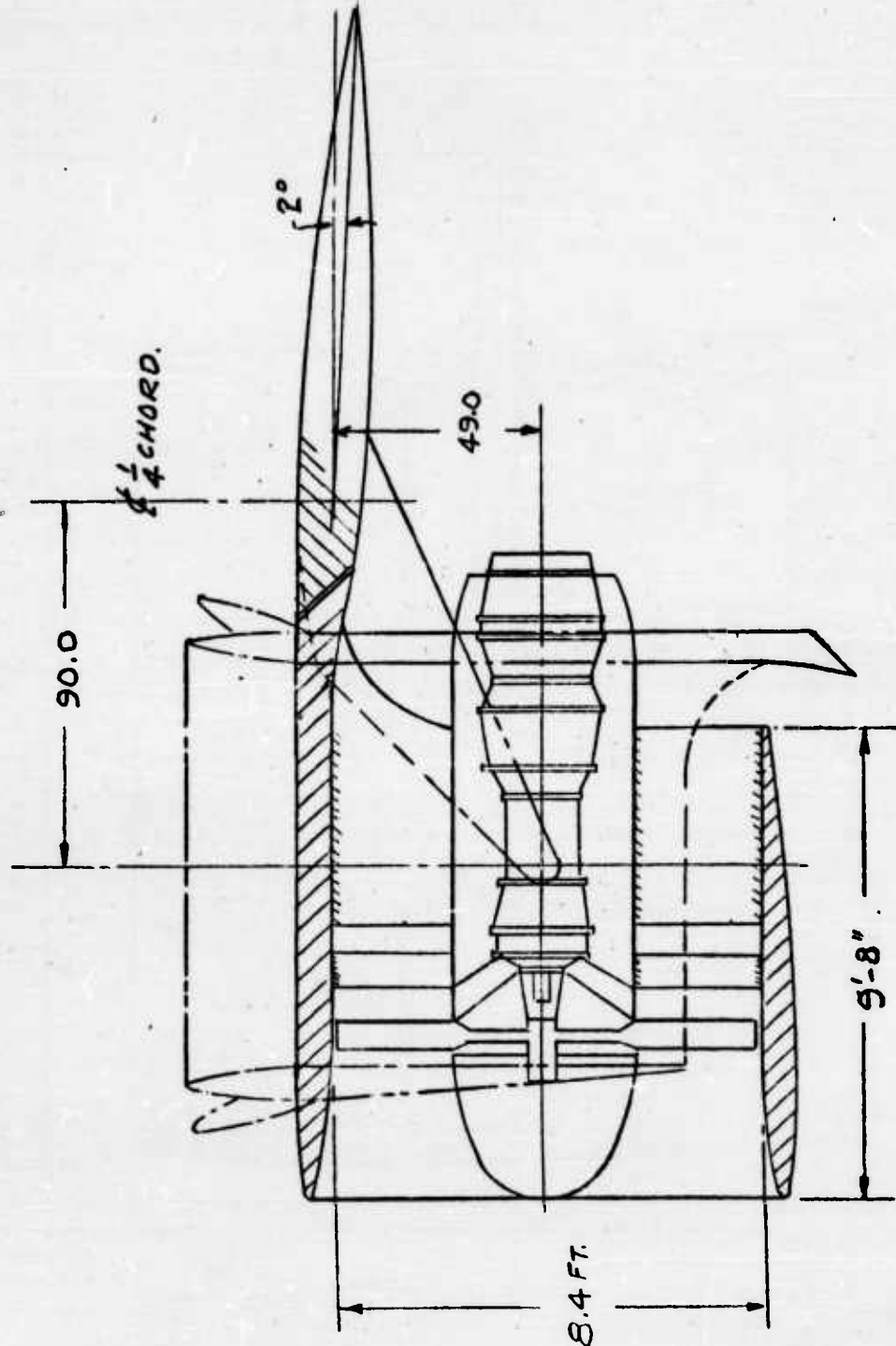

INTERNAL DUCT - D181-960-009
Allison 550-81

CONFIDENTIAL

FIGURE 66

CONFIDENTIAL

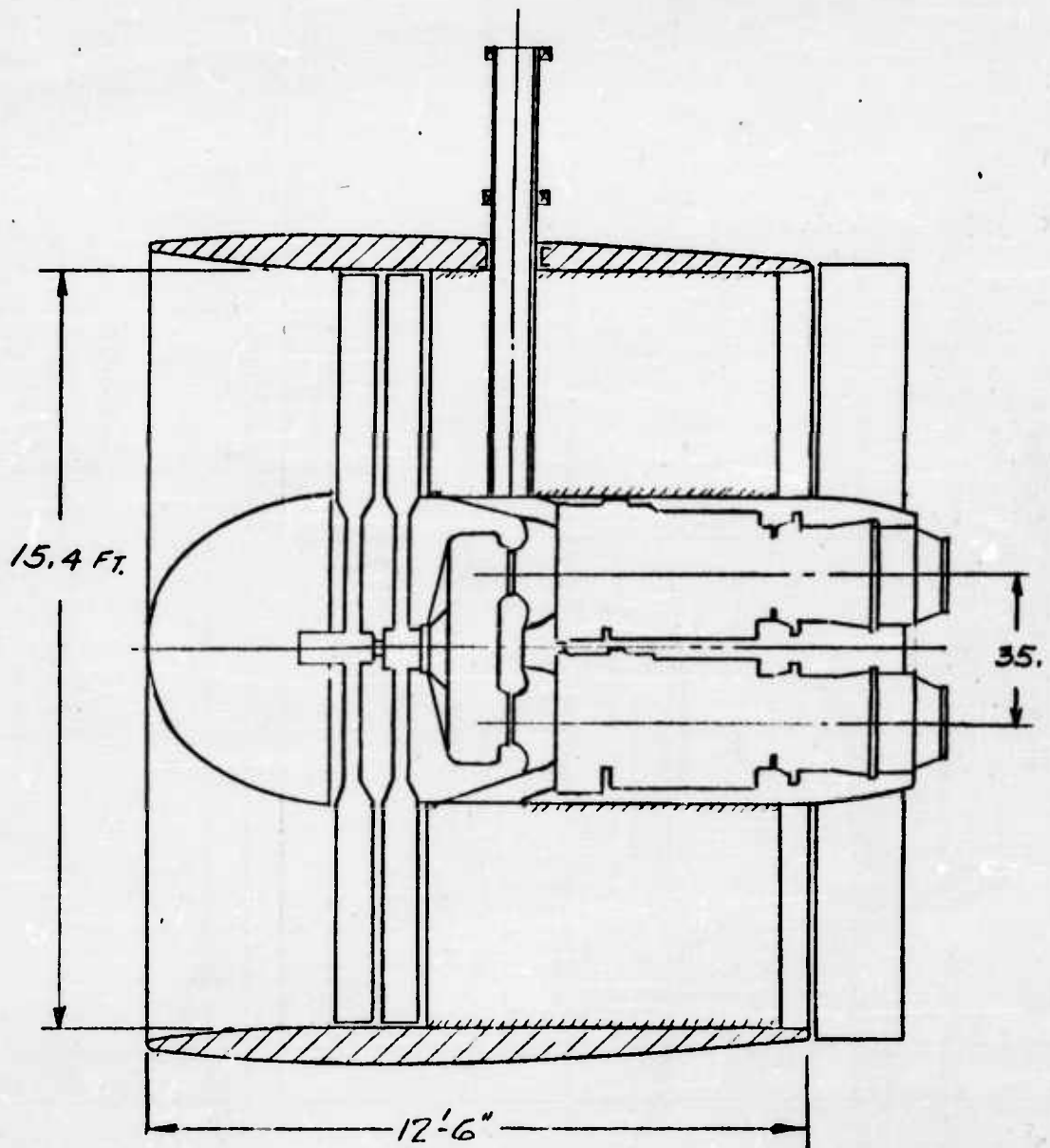

OUTBOARD DUCT - D181-960-007
Rolls Royce RB-109

CONFIDENTIAL

FIGURE 67

CONFIDENTIAL

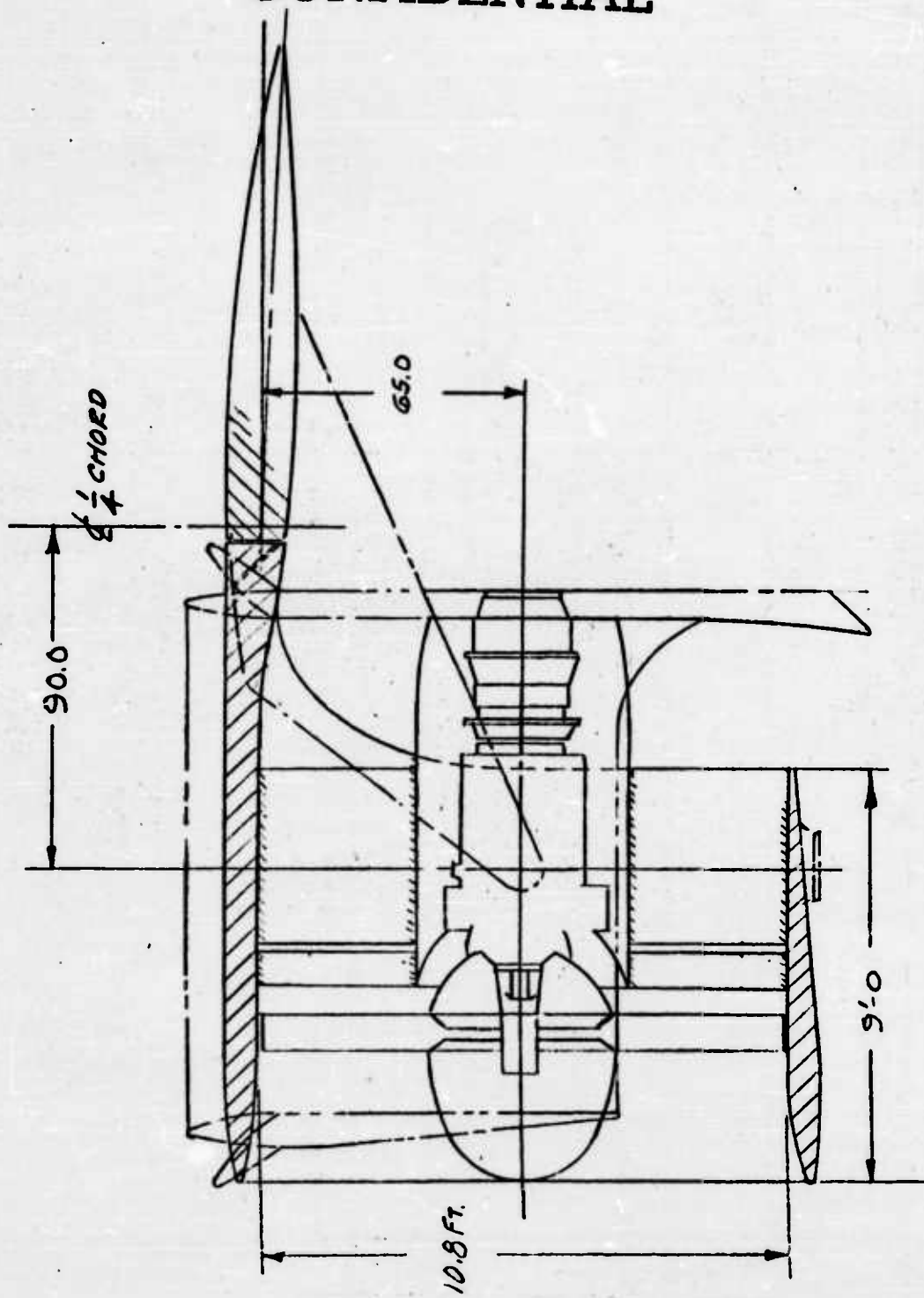

INBOARD DUCT - D181-960-007
Rolls Royce RB-109

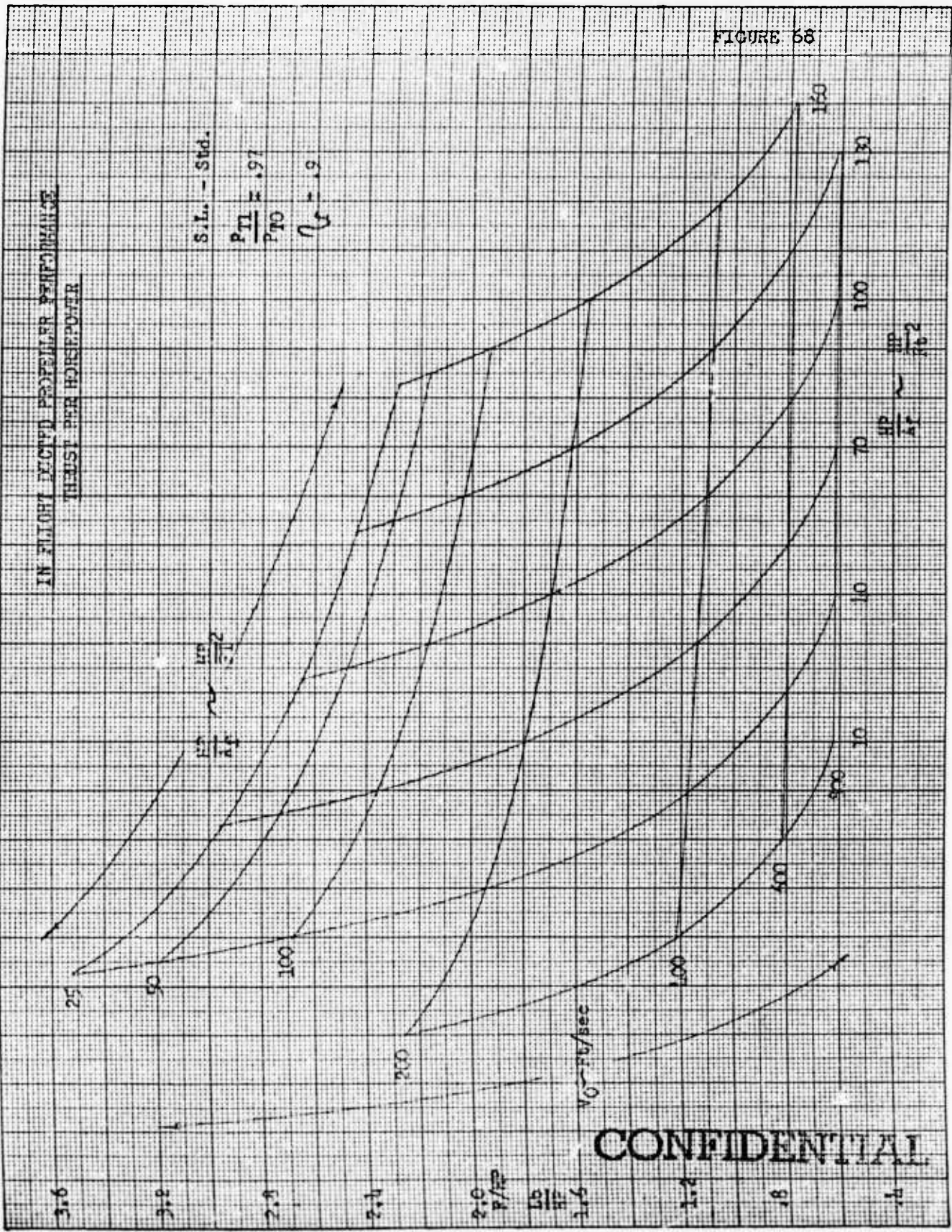
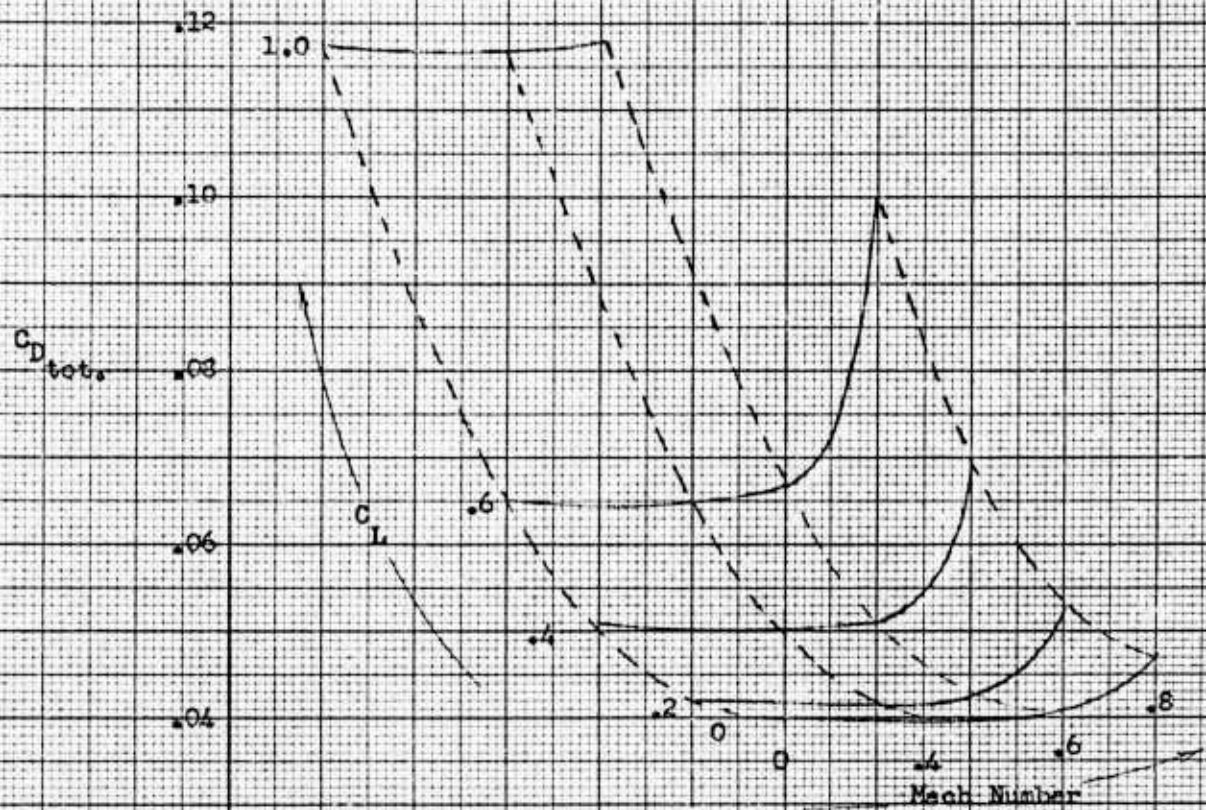

FIGURE 69

DRAG COEFFICIENT
D 181-960-007 & -009

Note: Reduce C_D by $\Delta 0022$
for - 009



CONFIDENTIAL

BY _____ DATE _____
CHECKED _____ DATE _____

BELL ~~CONFIDENTIAL~~ *Aircraft* CORPORATION

MODEL _____ PAGE 119
SHIP _____ REPORT D181-945-004

FIGURE 70

LIFT CURVE SLOPE
D 181-960-007 & -009

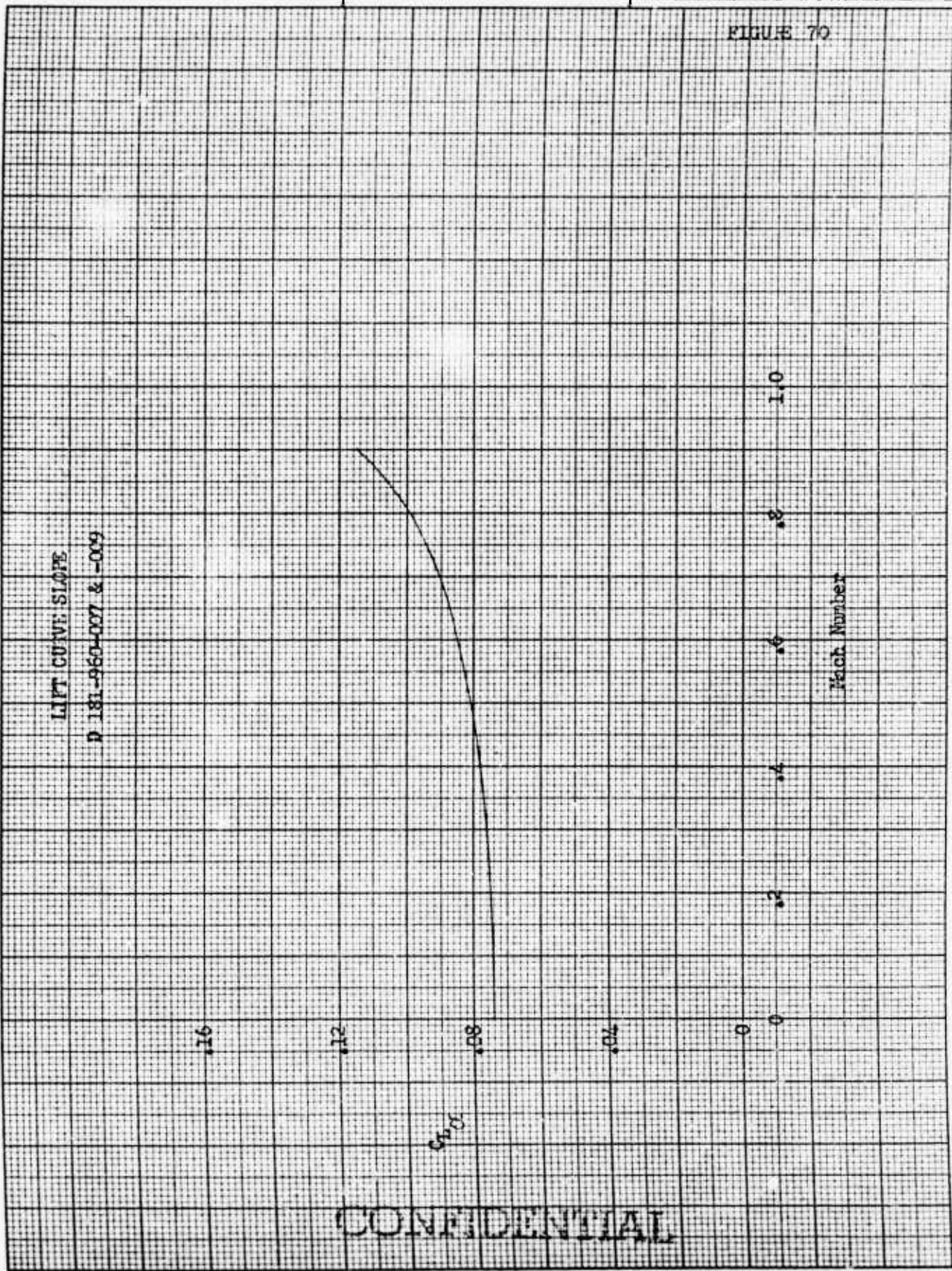

CONFIDENTIAL

FIGURE 71

SHROUD DRAG COEFFICIENT

$$D = C_D \rho a^2$$

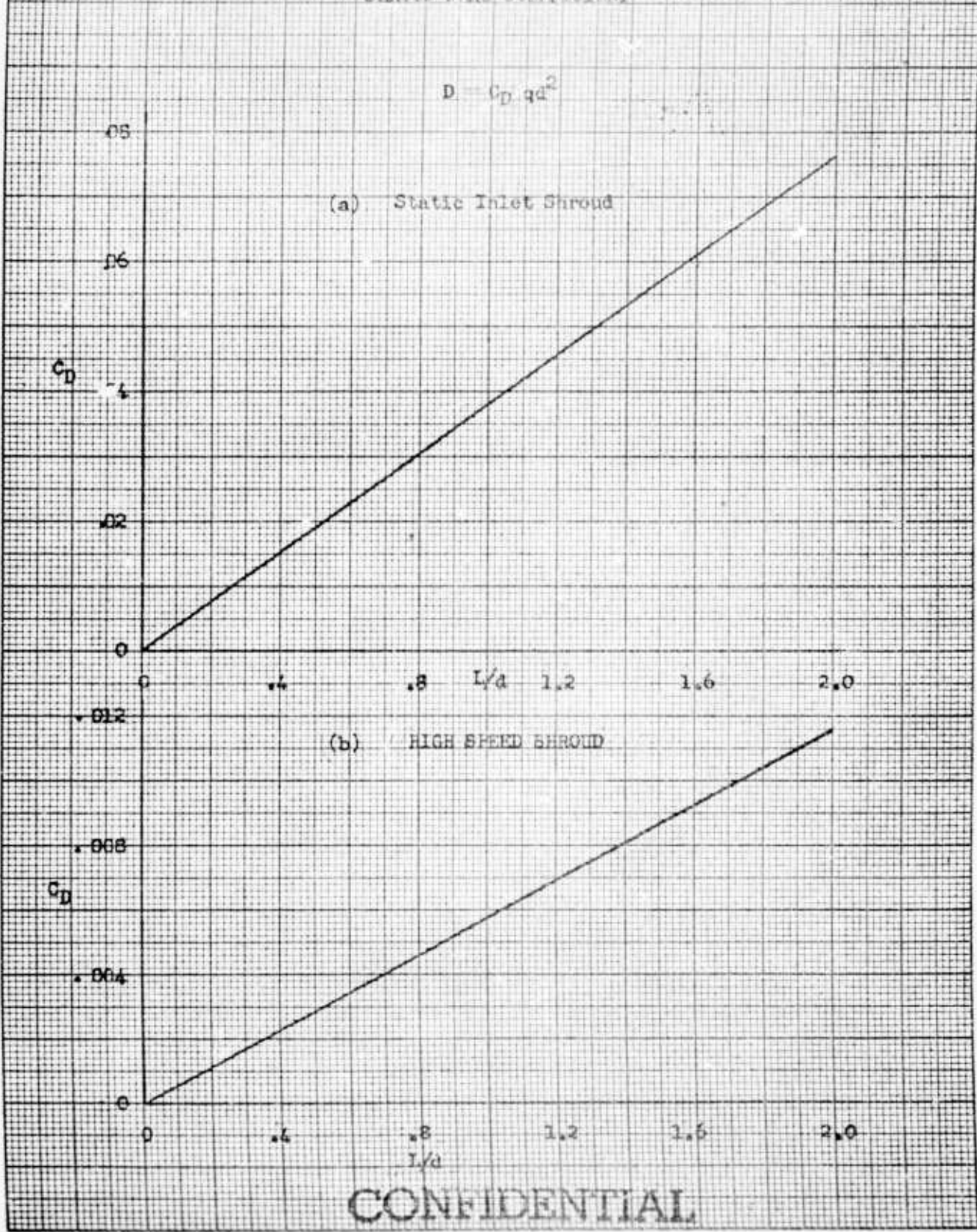

CONFIDENTIAL

SHROUD DRAG
S.L. STD. COND.

FIGURE 72

Diameters
= 15 ft.

HIGH SPEED INLET
STATIC INLET

DRAG - THOUSANDS OF POUNDS

16
14
12
10
8
6
4
2
0

10 ft.
5 ft.
15 ft.
10 ft.
5 ft.

0 100 200 300 400 500 600

VELOCITY - mph

CONFIDENTIAL

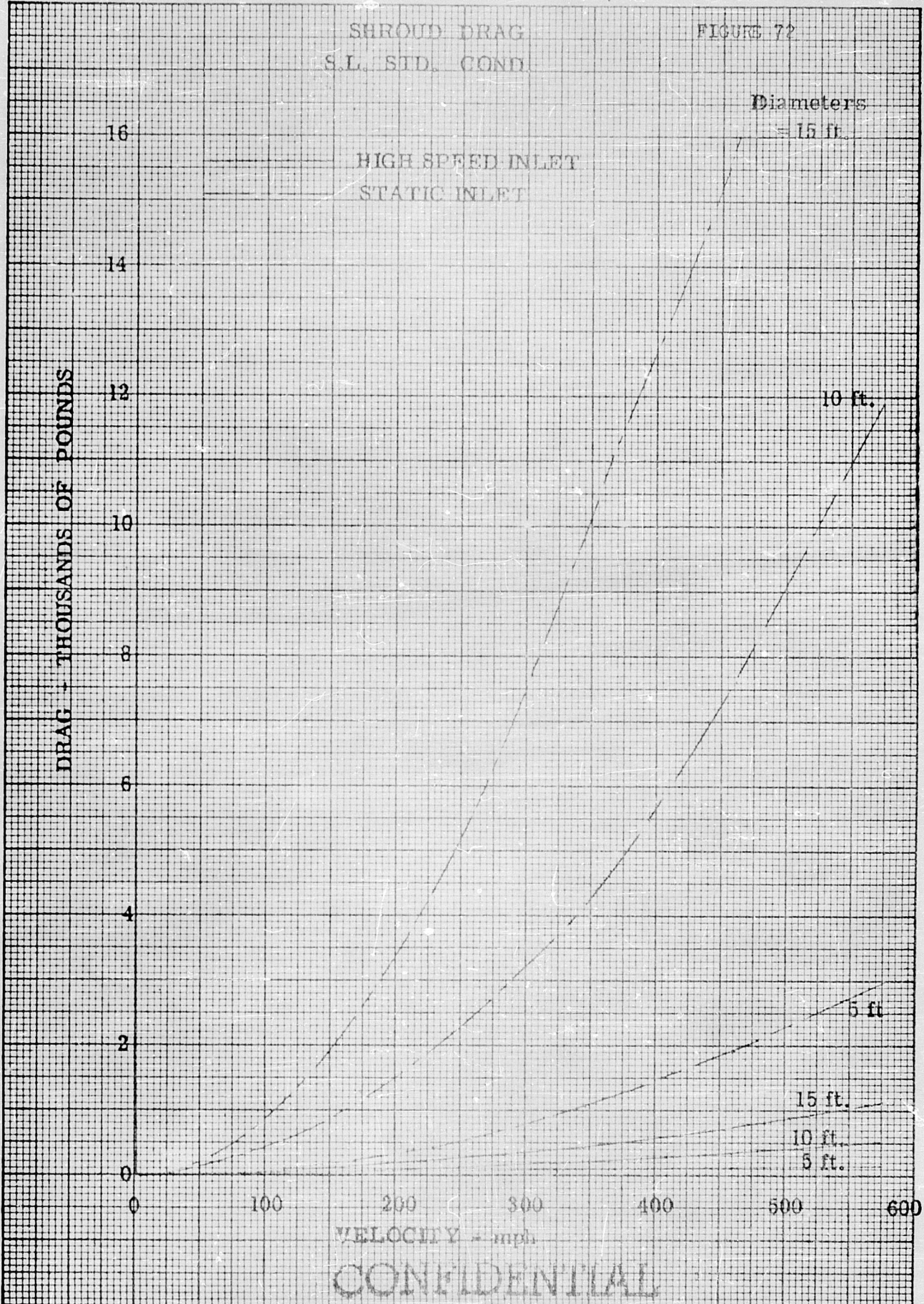

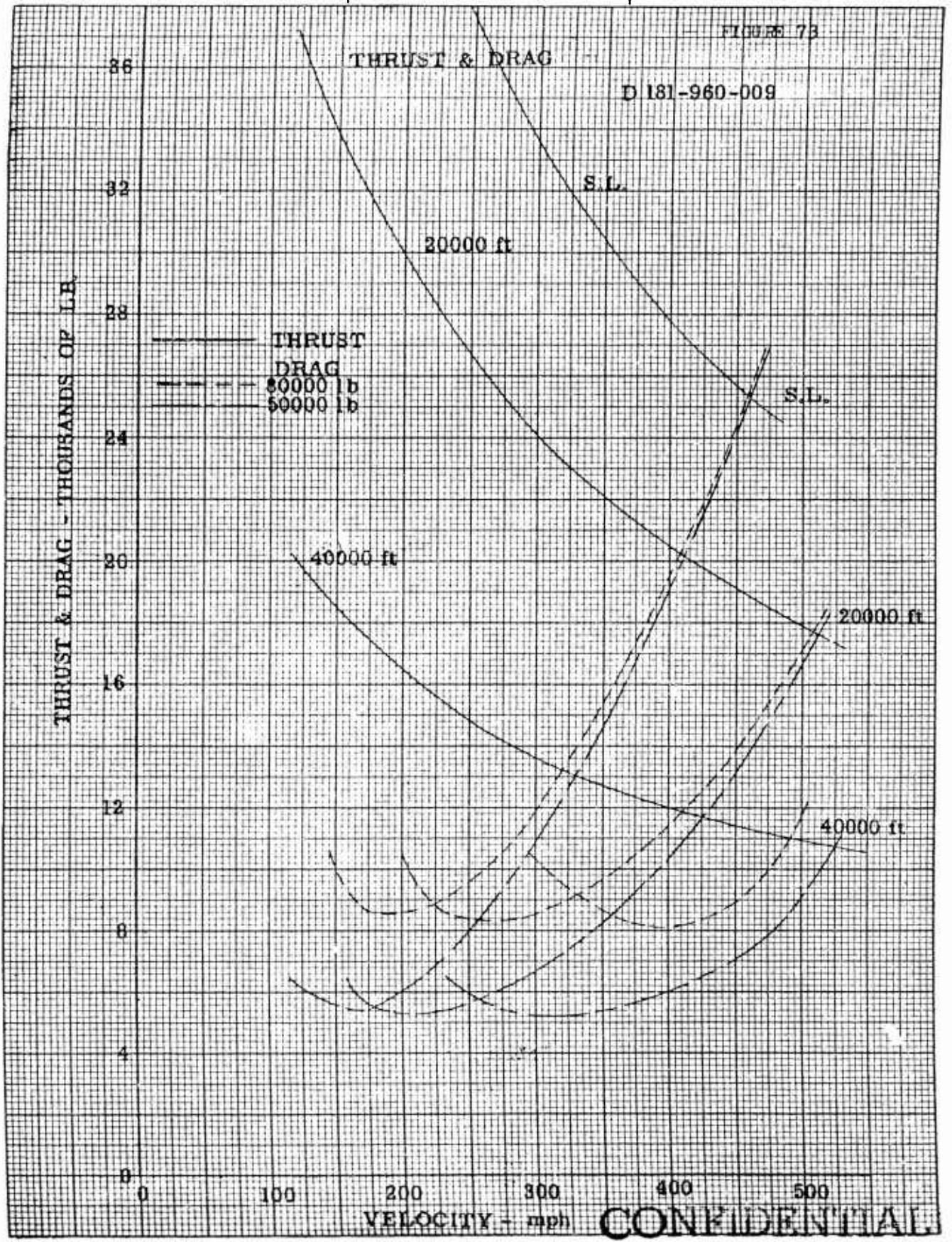

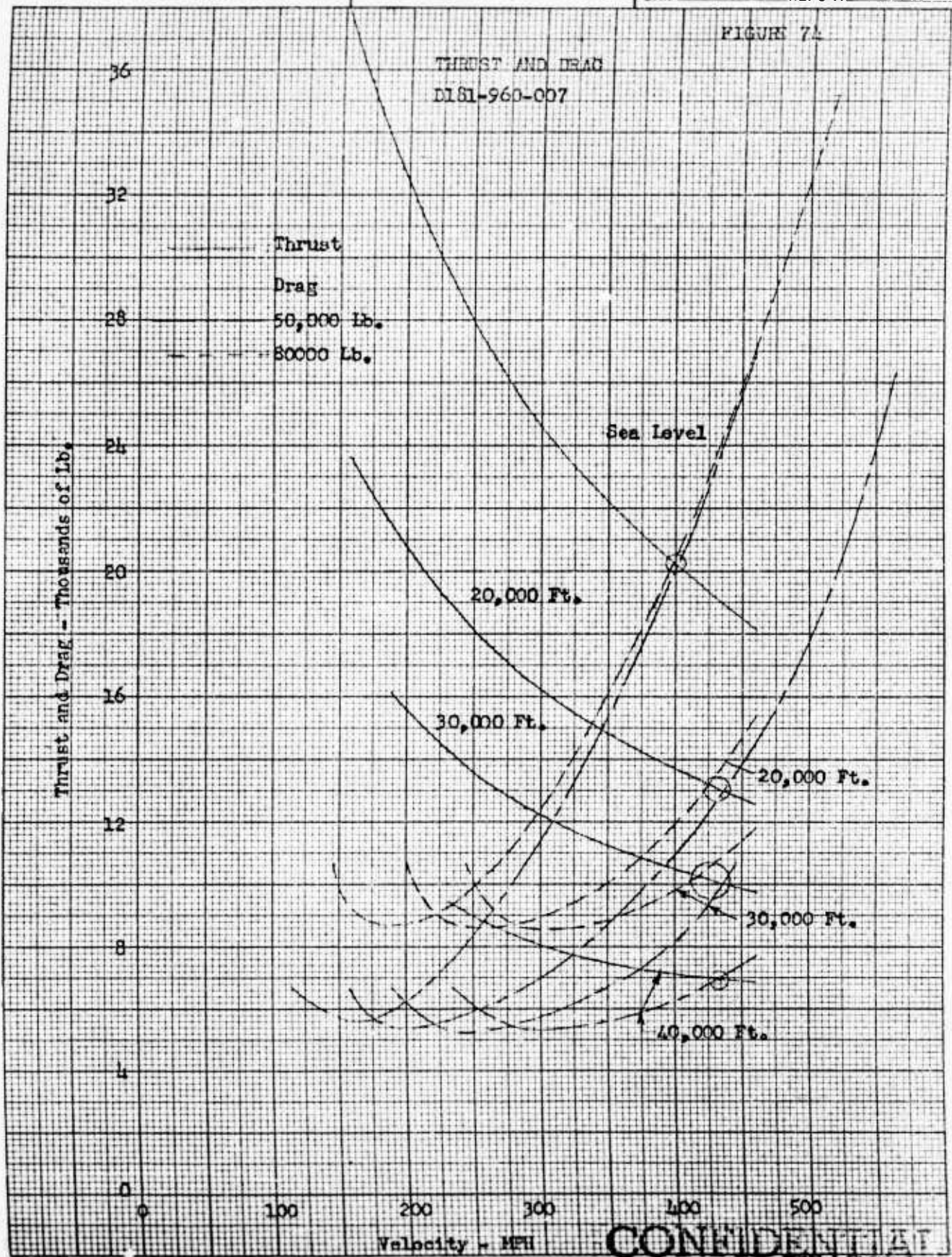
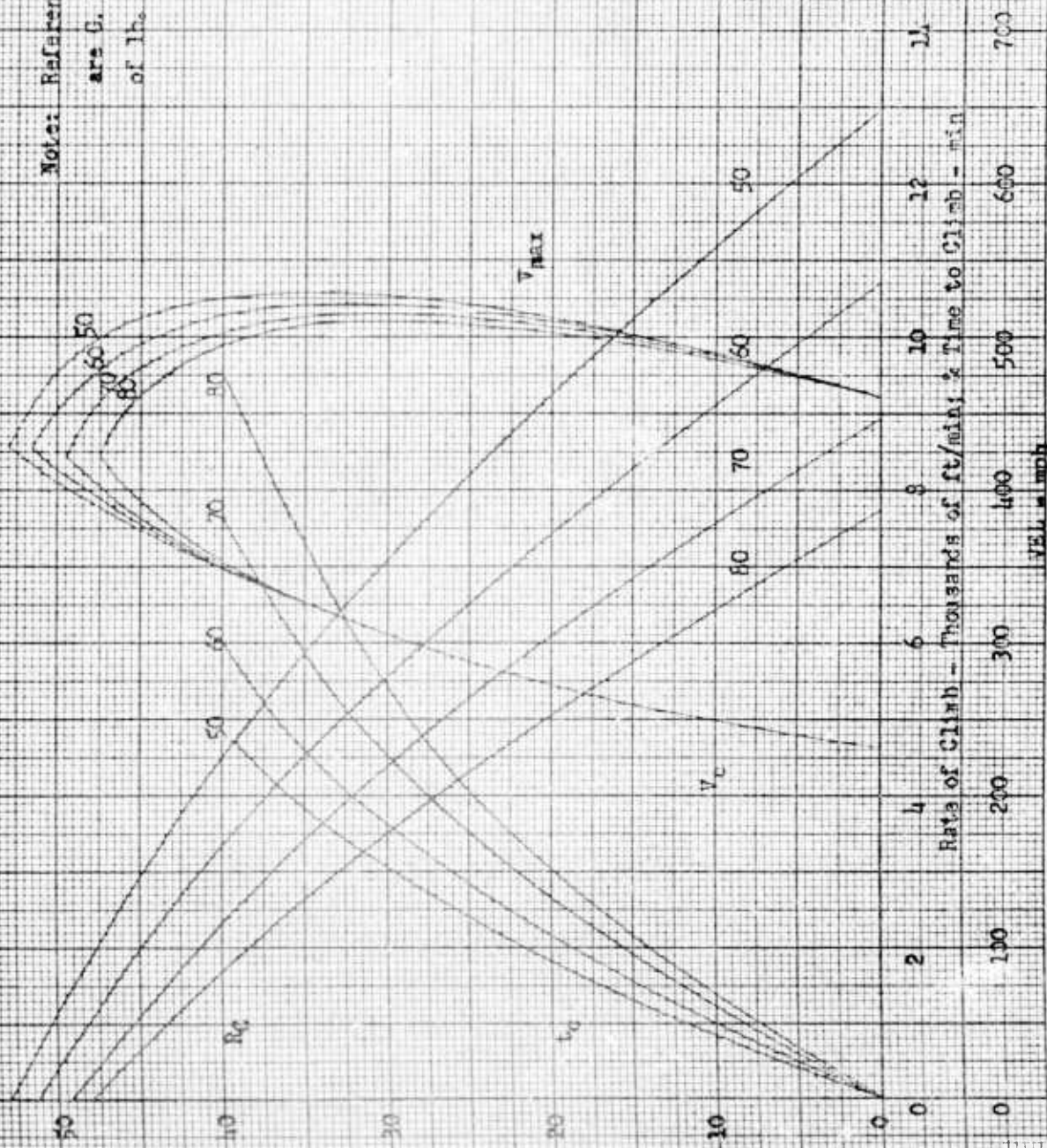

FIGURE 75

CLASSICAL PERFORMANCE
 D 181-960-009

Note: Reference Weights on Curves
 are G. W. in Thousands
 of lbs.



Alt - Thousands of ft

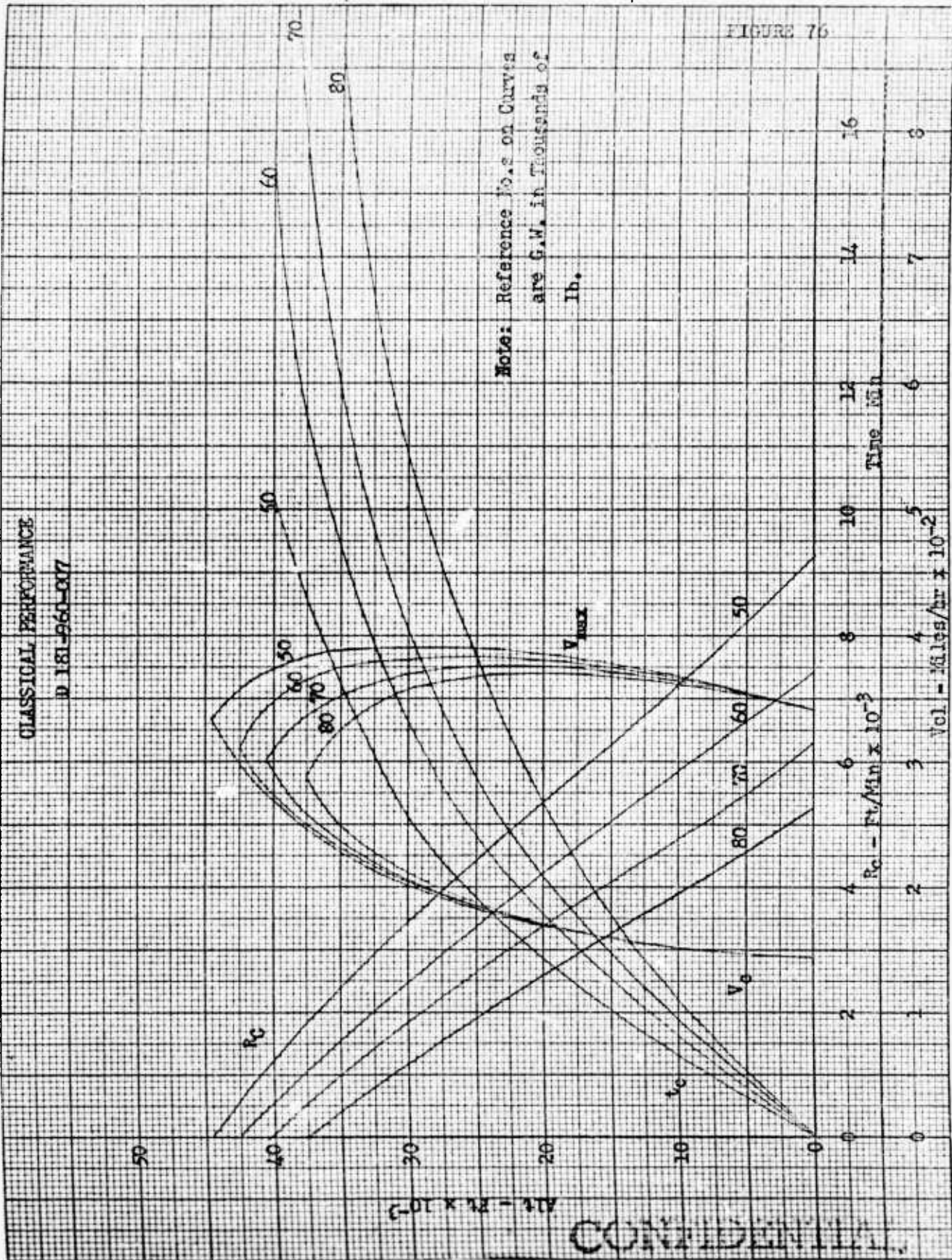

CONFIDENTIAL

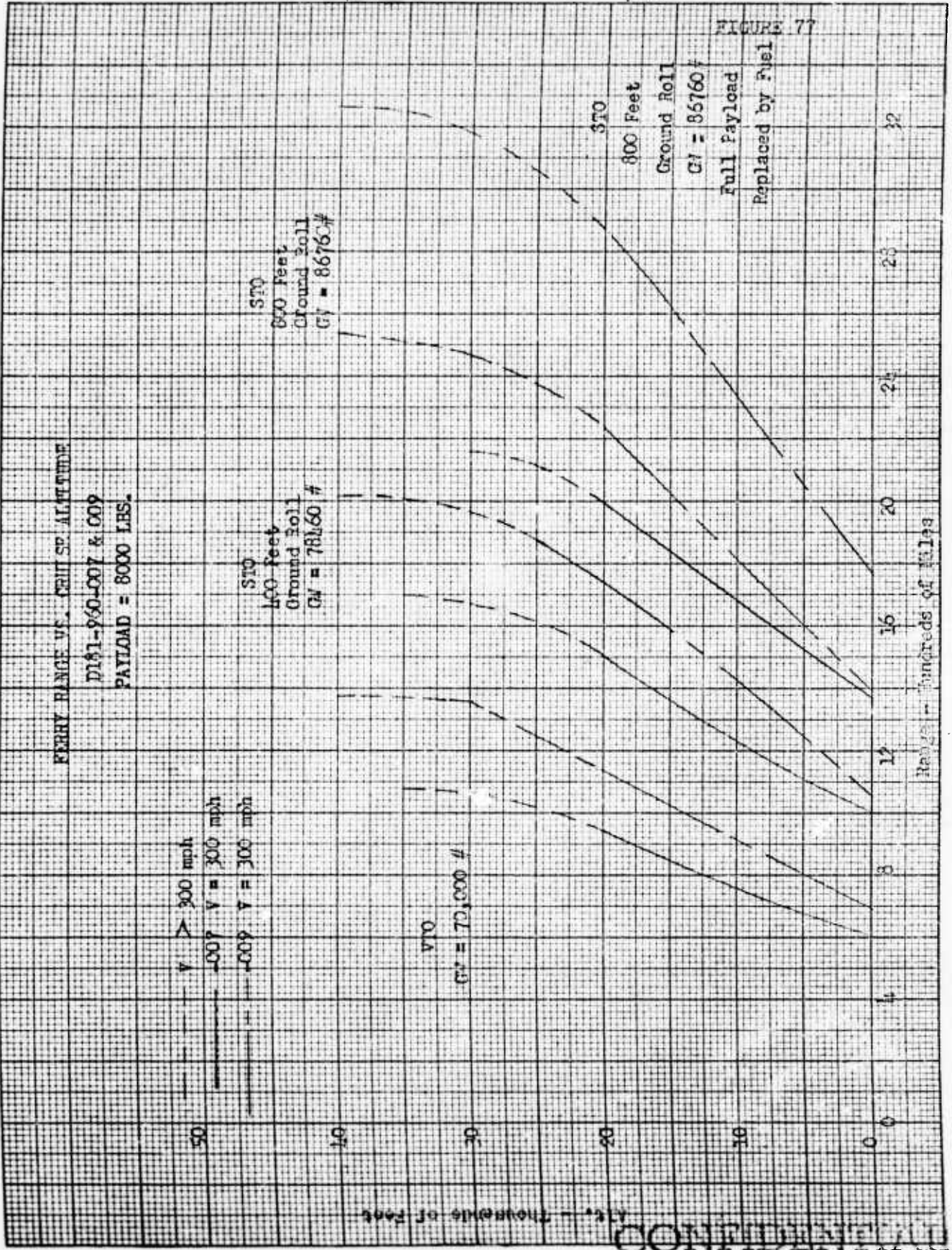

CONFIDENTIAL

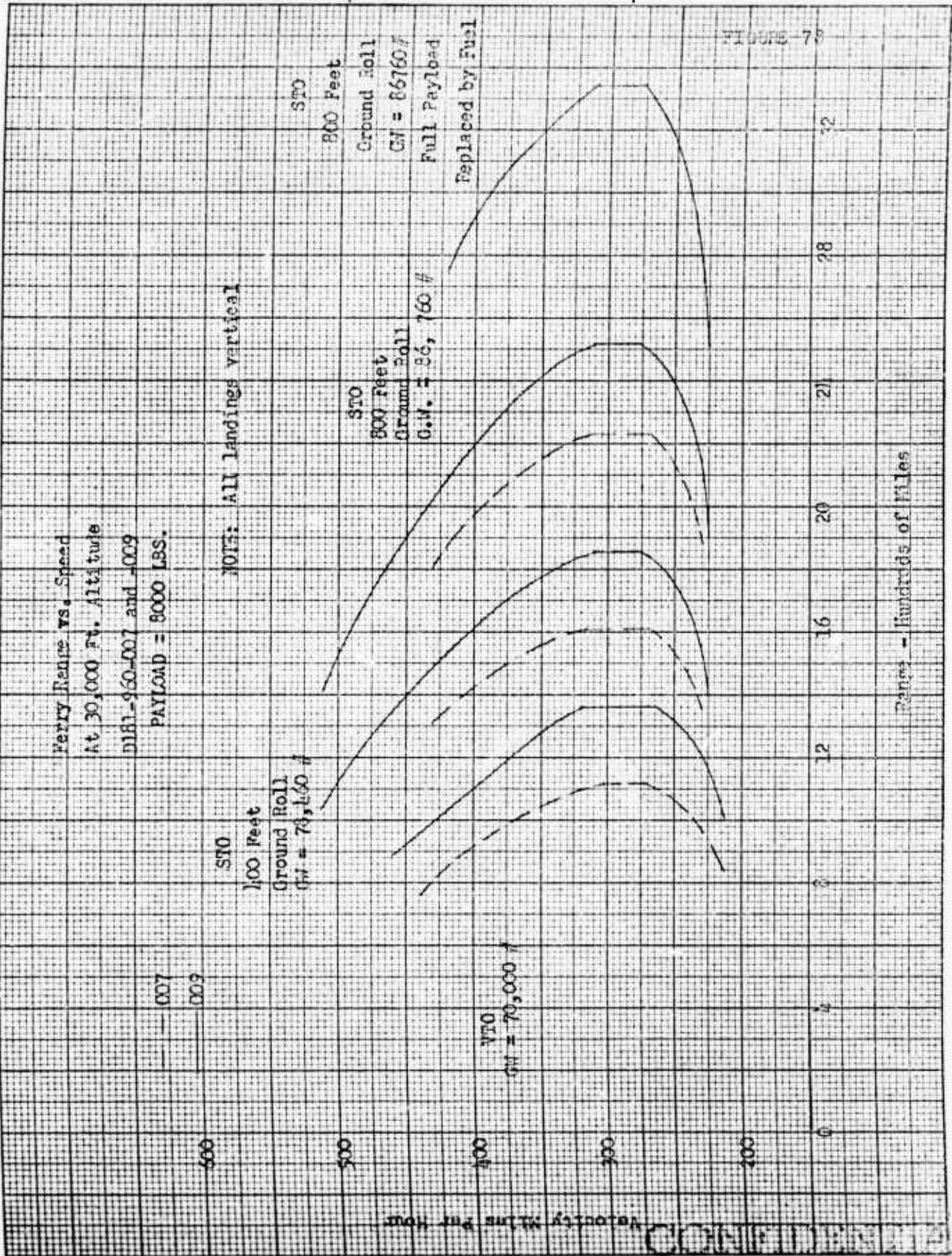

LIST OF SYMBOLS

$R, A.R.$	=	Aspect ratio, b^2/S
A	=	Cross sectional area
Alt.	=	Altitude
b	=	Span
C_D	=	Drag coefficient
C_L	=	Lift coefficient
$C_{L_{max}}$	=	Maximum lift coefficient
$C_{L_{\alpha}}$	=	Lift curve slope
d	=	Duct diameter
d	=	Fuselage and nacelle diameter
D	=	Drag, $C_D q S$
F_e, T	=	Thrust
F	=	Frontal area
FR	=	Fineness ratio
g	=	Acceleration due to gravity
G.W.	=	Gross weight
h	=	Altitude
HP	=	Horsepower
HP/A_i	=	Disc loading in terms of inlet area
HP/A_f	=	Disc loading at the propeller
L	=	Lift, $C_L q S$
L/d	=	Shroud length/duct diameter
l	=	Fuselage length
M	=	Mach number

CONFIDENTIAL
BELL *Aircraft* CORPORATION

N. mi/lb	=	Nautical miles/pound
P_{t_1}/P_o	=	Pressure recovery factor
q	=	Dynamic pressure
R_c	=	Rate of climb
Ref.	=	Reference
S	=	Wing and empennage area
W/S	=	Wing loading
SFC	=	Specific fuel consumption
Stat. Mi.	=	Statute miles
t_c	=	Time to climb
T/W	=	Thrust to weight ratio
V	=	Airspeed or free stream velocity
V_c	=	Climb speed
V_{max}	=	Maximum velocity
Wt.	=	Weight
α	=	Angle of attack
η	=	Efficiency
λ	=	Angle between thrust line and airplane axis - thrust angle
ρ	=	Air density
Subscripts		
A	=	Airplane
e	=	exit
f	=	fan
i	=	inlet
o	=	free stream condition
req.	=	required
stat.	=	static
avail.	=	available
tot.	=	total

REFERENCES

1. Macey, R.: "Ducted Propeller Assault Transport Study - Duct and Propeller Analysis". Bell Aircraft Corporation Report No. D181-945-006, May 15, 1956
2. Vollo, S. and Brassaw, L.: "Ducted Propeller Assault Transport Study - Stability and Control". Bell Aircraft Corporation Report No. D181-945-005, May 15, 1956
3. Sing, E.: "Ducted Propeller Assault Transport Study - Design Report". Bell Aircraft Corporation Report No. D181-945-002, May 15, 1956
4. Stearns, B.; Chiappinelli, B.; Hall, W.: "Ducted Propeller Assault Transport Study - Preliminary Structural Analysis". Bell Aircraft Corporation Report No. D181-945-007, May 15, 1956
5. Gill, W. and Morris, D.: "Determination of Performance Parameters - Division D2 - Supersonic Drag Coefficient". Bell Aircraft Corporation Report No. 02-981-009, January 4, 1954
6. Wright Aeronautical Corporation: Advance Specification No. 875 - "Model Specification Engine, Aircraft, Turbo-Prop, YT49-W-1 for Air Material Command", February 19, 1947
7. Rolls Royce; T.S.D. Publication 499, "R.B. 109 Engine, Initial Project Performance Data and Installation Notes", June 1953 (Reproduced by Westinghouse)
8. Allison Division of General Motors, Preliminary Model Specification No. 394-B, "Allison Model 550-B1 Turbo-Prop Engine", January 5, 1956
9. Zabinsky, J. M.: "Ducted Propeller Assault Transport Study - Survey of the State of the Art". Bell Aircraft Corporation Report No. D181-945-003, May 15, 1956

CONFIDENTIAL
BELL *Aircraft* CORPORATION

10. Dufort, R. H. and Meullen, N. F.: "Jet Convertoplane, Vertical Take-Off Fighter". Bell Aircraft Corporation Report No. D-109-945-003, November 9, 1951
11. Roehrs, F. S.; Zabinsky, J. M.; O'Malley, J. A., Jr.: "A General Dynamic Stability and Control Analysis of Jet Powered VTOL Aircraft - Part I". Bell Aircraft Corporation Report No. 65-978-002, October 31, 1952
12. Zabinsky, J. M.; Isom, J., Jr.; Landphair, L. C.; O'Malley, J. A., Jr.: "A General Performance Analysis of Jet Powered VTOL Aircraft - Part I". Bell Aircraft Corporation Report No. 65-978-003, November 30, 1952
13. Zabinsky, J. M. and O'Malley, J. A., Jr.: "A Review of Available Literature on Jet Propelled Vertical Take-Off and Landing Aircraft". Bell Aircraft Corporation Report No. 65-978-004, January 1, 1953
14. Zabinsky, J. M. and Isom, J., Jr.: "A General Performance Analysis of Jet Powered VTOL Aircraft - Part II". Bell Aircraft Corporation Report No. 65-978-005, February 20, 1953
15. Roehrs, F. S. and Landphair, L. C.: "A General Dynamic Stability and Control Analysis of Jet Powered VTOL Aircraft - Part II". Bell Aircraft Corporation Report No. 65-978-006, February 28, 1953
16. Wynn, W.; Isom, J., Jr.; Zabinsky, J. M.; O'Malley, J. A., Jr.: "A Preliminary Study of the Tactical Applications of Jet Powered VTOL Aircraft as Affected by Size and Weight". Bell Aircraft Corporation Report No. 65-978-007, February 20, 1953
17. Payne, R. L.: "Evaluation of Control Methods for VTOL Aircraft". Bell Aircraft Corporation Report No. 65-989-001, December 29, 1952

18. Dufort, R. H. and Buddenhagen, T. F.: "Control System Considerations for VTOL Aircraft". Bell Aircraft Corporation Report No. 65-989-002, February 28, 1953
19. Hall, W.: "Preliminary Weight Estimates and Moment of Inertia Calculations for VTOL Aircraft". Bell Aircraft Corporation Report No. 65-942-001, February 28, 1953
20. Bell Aircraft Corporation: "VTOL, A Review of the Study Program". Contract AF33(616)-84, December 1952
21. Bell Aircraft Corporation: "Final Summary Report on the Study Program, Vertical Take-Off and Landing Aircraft". Bell Aircraft Corporation Report No. 65-989-003, March 9, 1953
22. Whedon, R.: "Preliminary Specifications for an Air Test Vehicle". Bell Aircraft Corporation Report No. 65-947-001, February 27, 1953
23. O'Malley, J. A.; Zabinsky, J.; Roehrs, F.; Isom, J.; Landphair, L.: "Aerodynamics of the Bell VTOL Air Test Vehicle". Bell Aircraft Corporation Report No. 65-978-008, October 26, 1953
24. Bell Aircraft Corporation: "VTOL Day Fighter Weapon System, Summary Report". Bell Aircraft Corporation Report No. D139-945-027, July 27, 1954
25. O'Malley, J. A.; Zabinsky, J.; et. al: "VTOL Dayfighter Weapon System - Aerodynamic Data". Bell Aircraft Corporation Report No. D139-945-028, July 15, 1954
26. Bell Aircraft Corporation: "VTOL Dayfighter Weapon System - Structural and Weight Data". Bell Aircraft Corporation Report No. D139-945-029, July 1954

27. Kane, J. B.; Vollo, S. D.; Roehrs, F. S.; Isom, J.: "Hovering Stability and Control". Bell Aircraft Corporation Report No. D139-945-103, December 1954
28. Kane, J. B. and Vollo, S. D.: "Level Flight Stability and Control". Bell Aircraft Corporation Report No. D139-945-104, December 1954
29. Van Summern, J. S.; Anderson, F.; Landstrom, W.: "Structural Data". Bell Aircraft Corporation Report No. D139-945-105, December 1954
30. Tilyou, C. E.: "Weight Data". Bell Aircraft Corporation Report No. D139-945-106, December 1954
31. Marquardt Aircraft Company: Proposal No. 834 - "Development of Model MA35 Vertiburner for Bell VTOL Airplane". July 1954
32. Bell Aircraft Corporation: "Ducted Fan Power Plant Study Proposal". Bell Aircraft Corporation Preliminary Design Report No. M29-001, July 30, 1954
33. Bell Aircraft Corporation: "E-182A Ducted Propeller Test Airplane". Bell Aircraft Corporation Report No. D182-945-002, August 26, 1955
34. Bell Aircraft Corporation: "Technical Summary Report". Bell Aircraft Corporation Report No. D139-945-100, December 22, 1954
35. Bell Aircraft Corporation: "Phase II Design Report". Bell Aircraft Corporation Report No. D139-945-108, March 31, 1955
36. Bell Aircraft Corporation: "Final Summary Report". Bell Aircraft Corporation Report No. D139-945-109, March 31, 1955
37. Military Specification: "Charts; Standard Aircraft Characteristics and Performance, Piloted Aircraft". MIL-C-5011A, November 5, 1951

UNCLASSIFIED

UNCLASSIFIED