

UNCLASSIFIED

AD NUMBER

AD102027

CLASSIFICATION CHANGES

TO: unclassified

FROM: confidential

LIMITATION CHANGES

TO:
Approved for public release, distribution unlimited

FROM:
Distribution authorized to U.S. Gov't. agencies and their contractors; Administrative/Operational Use; 27 JUL 1956. Other requests shall be referred to National Aeronautics and Space Administration, Washington, DC.

AUTHORITY

NASA TR Server website; NASA TR Server website

THIS PAGE IS UNCLASSIFIED

CONFIDENTIAL

AD 102027

Armed Services Technical Information Agency

Reproduced by

DOCUMENT SERVICE CENTER

KNOTT BUILDING, DAYTON, 2, OHIO

This document is the property of the United States Government. It is furnished for the duration of the contract and shall be returned when no longer required, or upon recall by ASTIA to the following address: Armed Services Technical Information Agency, Document Service Center, Knott Building, Dayton 2, Ohio.

NOTICE: WHEN GOVERNMENT OR OTHER DRAWINGS, SPECIFICATIONS OR OTHER DATA ARE USED FOR ANY PURPOSE OTHER THAN IN CONNECTION WITH A DEFINITELY RELATED GOVERNMENT PROCUREMENT OPERATION, THE U. S. GOVERNMENT THEREBY INCURS NO RESPONSIBILITY, NOR ANY OBLIGATION WHATSOEVER; AND THE FACT THAT THE GOVERNMENT MAY HAVE FORMULATED, FURNISHED, OR IN ANY WAY SUPPLIED THE SAID DRAWINGS, SPECIFICATIONS, OR OTHER DATA IS NOT TO BE REGARDED BY IMPLICATION OR OTHERWISE AS IN ANY MANNER LICENSING THE HOLDER OR ANY OTHER PERSON OR CORPORATION, OR CONVEYING ANY RIGHTS OR PERMISSION TO MANUFACTURE, USE OR SELL ANY PATENTED INVENTION THAT MAY IN ANY WAY BE RELATED THERETO.

CONFIDENTIAL

**NOTICE: THIS DOCUMENT CONTAINS INFORMATION AFFECTING THE
NATIONAL DEFENSE OF THE UNITED STATES WITHIN THE MEANING
OF THE ESPIONAGE LAWS, TITLE 18, U.S.C., SECTIONS 793 and 794.
THE TRANSMISSION OR THE REVELATION OF ITS CONTENTS IN
ANY MANNER TO AN UNAUTHORIZED PERSON IS PROHIBITED BY LAW.**

CONFIDENTIAL

Copy 25
RM L56E25

NACA RM L56E25

102027

FILE COPY



RESEARCH MEMORANDUM

WIND-TUNNEL INVESTIGATION AT HIGH SUBSONIC SPEEDS OF JET,
SPOILER, AND AILERON CONTROLS ON A 1/16-SCALE MODEL
OF THE DOUGLAS D-558-II RESEARCH AIRPLANE

By Raymond D. Vogler

Langley Aeronautical Laboratory
Langley Field, Va.

CLASSIFIED DOCUMENT

This material contains information affecting the National Defense of the United States within the meaning of the espionage laws, Title 18, U.S.C., Secs. 793 and 794, the transmission or revelation of which in any manner to an unauthorized person is prohibited by law.

**NATIONAL ADVISORY COMMITTEE
FOR AERONAUTICS**

WASHINGTON

July 27, 1956

CONFIDENTIAL

AUG 3 1956

56AA

46389

U

NACA RM L56E25

CONFIDENTIAL

NATIONAL ADVISORY COMMITTEE FOR AERONAUTICS

RESEARCH MEMORANDUM

WIND-TUNNEL INVESTIGATION AT HIGH SUBSONIC SPEEDS OF JET,
SPOILER, AND AILERON CONTROLS ON A 1/16-SCALE MODEL
OF THE DOUGLAS D-558-II RESEARCH AIRPLANE

By Raymond D. Vogler

SUMMARY

An investigation was made in the Langley high-speed 7- by 10-foot tunnel through a Mach number range from 0.60 to 0.96 to determine the characteristics of a wing trailing-edge jet control on a 1/16-scale model of the Douglas D-558-II research airplane. The control was operated with ram air obtained from wing-tip inlets. The characteristics of ailerons and trailing-edge spoilers were also obtained for comparison with the jet control.

The results indicated that at small angles of attack and at a Mach number of 0.60 the jet control was 85 percent as effective as the fully deflected ailerons, but at a Mach number of 0.96 the jet control was 25 percent more effective than the ailerons. This change in relative effectiveness is attributed to the fact that the jet control gave constant effectiveness through the Mach number range while the aileron effectiveness decreased rapidly between Mach numbers of 0.90 and 0.96. The spoilers, which projected 0.052 of the wing chord, were slightly more effective than either the ailerons or jets but showed about the same variation with Mach number as the ailerons. All three controls decreased in effectiveness at the higher angles of attack; however, all showed considerable effectiveness through the angle-of-attack range investigated. Some of the decrease in effectiveness of the jet control at high angles of attack can be attributed to the loss in the ratio of the pressure in the wing plenum chamber to the tunnel stagnation pressure. Increasing the diameter of the holes in the jet controls or increasing the control span gave more control effectiveness as long as the total jet-exit area did not greatly exceed the inlet area. The drag of the jet control was much greater than that of either the ailerons or spoilers. Most of this drag results from the installation of the jet-control system and not from its operation.

CONFIDENTIAL

564A

46389

INTRODUCTION

The growing need for simplified airplane controls operating with smaller actuating forces than are now required has aroused considerable interest in the possibility of using air jets as controls. Some previous investigations of jet controls are reported in references 1 to 4.

The purpose of this investigation was to determine, primarily, the rolling-moment characteristics at high subsonic speeds of trailing-edge jet controls on a 1/16-scale model of the D-558-II research airplane, and to obtain a comparison of the effectiveness of the jet controls with the more conventional solid spoilers and ailerons. Jet controls with hole diameters from 0.063 inch to 0.172 inch were supplied ram air by means of a constant-diameter inlet in a wing-tip nacelle on each wing. Control span and location were also investigated. Force and moment data were obtained through a Mach number range of 0.6 to 0.96 and an angle-of-attack range of -6° to 21° in the Langley high-speed 7- by 10-foot tunnel. In addition, some drag data were obtained with the inlet closed with a faired plug and with the inlet removed so that only the plenum chamber with the thickened trailing edge was attached to the wing.

COEFFICIENTS AND SYMBOLS

The system of axes used and the positive directions of forces and moments used in the reduction of data are shown in figure 1. The origin of the system of axes was on the fuselage center line at a longitudinal position corresponding to the projection of the quarter-chord point of the mean aerodynamic chord onto the fuselage center line. The lift and drag coefficients are determined about the wind axes, and the rolling-, yawing-, and pitching-moment coefficients are determined about the body axes.

C_L lift coefficient, $\frac{\text{Lift}}{qS}$

C_D drag coefficient, $\frac{\text{Drag}}{qS}$

C_m pitching-moment coefficient, $\frac{\text{Pitching moment}}{qS\bar{c}}$

C_l rolling-moment coefficient, $\frac{\text{Rolling moment}}{qSb}$

C_N	yawing-moment coefficient, $\frac{\text{Yawing moment}}{qSb}$
C_Y	side-force coefficient, $\frac{\text{Side force}}{qS}$
ΔC_l	net rolling-moment coefficient produced by the control
ΔC_N	net yawing-moment coefficient produced by the control
q	dynamic pressure, $\frac{\rho V^2}{2}$, lb/sq ft
ρ	mass density of air, slugs/cu ft
V	free-stream air velocity, ft/sec
S	wing area (original model), sq ft
b	wing span (original model), ft
c	local wing chord, ft
\bar{c}	mean aerodynamic chord of wing, ft
M	Mach number
α	angle of attack of fuselage, deg
p	total pressure in wing plenum chamber
p_t	tunnel stagnation pressure, lb/sq ft
w	weight flow of air, lb/sec
D	jet diameter, in.

Subscript:

w indicates wind axes (see fig. 1)

MODEL AND APPARATUS

The plain-wing model used in this investigation was a 1/16-scale aluminum model of the Douglas D-558-II research airplane with two minor

differences. These modifications were an enlarged section at the rear of the model fuselage to allow attachment of a sting support and a model thickness ratio at the wing tip of 10 percent instead of 12 percent. A three-view drawing of the model equipped with wing-tip inlets and jet controls is shown in figure 2 and a photograph in figure 3.

Details of the various controls investigated are given in figures 4 and 5. Controls were on both wing panels for each configuration. The jet-control configuration (fig. 4) consisted of a box-like plenum chamber replacing part of the trailing edge of the wing and a wing-tip nacelle having a 7/8-inch-diameter cylindrical inlet. The jet control with the smaller plenum chamber (fig. 4(a)) had 39 jet holes and was investigated with hole diameters of 0.0625 inch, 0.081 inch, and 0.099 inch. The control with the larger plenum chamber (fig. 4(b)) had only 24 holes and was investigated with hole diameters of 0.125 inch, 0.140 inch, 0.156 inch, and 0.172 inch. Part of the wing structure at the entrance to the plenum chambers of both configurations was faired to provide better flow in the throat, and in the larger chamber a turning vane was also used. Studs were used to reduce the flexibility of the walls of the larger chamber. Provision for obtaining aileron deflection by bending was made by cutting a spanwise groove along the 0.85-chord line of the original model without the tip nacelle (fig. 5). The trailing-edge spoiler was made of 0.016-inch-thick steel (fig. 5) and projected 0.052c. Figure 6 shows some modifications to the configuration used in assessing the drag increase.

The model was mounted on a sting-type support system in the Langley high-speed 7- by 10-foot tunnel. The sting was supported by a vertical strut downstream from the test section. The support system allowed the angle of attack of the model to be varied by rotating the model and sting in the vertical plane about an axis through the quarter-chord point of the wing mean aerodynamic chord. The forces and moments were measured by means of an electrical strain-gage balance mounted inside the fuselage. The forces and moments and the total pressure inside the plenum chamber were recorded on calibrated potentiometers.

TESTS

Data were obtained in the Langley high-speed 7- by 10-foot tunnel at Mach numbers of 0.60, 0.80, 0.85, 0.90, and 0.96 and at angles of attack generally from -6° to 21° except at the highest Mach number where the range was less. Tests were made of the original model with no controls, with trailing-edge spoilers, and with ailerons deflected equally and oppositely 7.5° and 15° . The plan form of the model was then changed by adding a wing-tip inlet and replacing part of the wing with a small plenum chamber with 39 jet holes in it at the trailing edge. Data for

this configuration were obtained with the holes closed and with open holes of three diameters - 0.0625 inch, 0.081 inch, and 0.099 inch. Some tests were also made of this configuration with the inlet closed with a round nose plug, and with the inlet removed but with the plenum chamber with jets closed attached to the wing. A larger plenum chamber with 24 jet holes and a wing-tip inlet of the same diameter as that used with the smaller plenum chamber but with a longer tail cone was installed. Tests of this configuration were made with the jet holes closed and with all holes open with jet-hole diameters of 0.125 inch, 0.140 inch, 0.156 inch, and 0.172 inch. In addition, data were obtained with the 0.125-inch jet holes with only 6, 12, and 18 inboard jets open, and data were obtained with the 0.172-inch jets with only 12 and with 18 outboard jets open.

The test Reynolds number (based on the mean aerodynamic chord) varied from about 1.45×10^6 at a Mach number of 0.6 to about 1.75×10^6 at a Mach number of 0.96.

CORRECTIONS

Blocking corrections as determined by the method of reference 5 have been applied to Mach number and dynamic pressure. Jet-boundary corrections were calculated by the method of reference 6 and were applied to the angle of attack and drag. The drag coefficients have also been adjusted to correspond to coefficients where the pressure at the base of the fuselage is equal to free-stream static pressure.

RESULTS AND DISCUSSION

The force and moment coefficients obtained in the investigation are presented in tabular form in tables I to III except for some drag-coefficient results of the effects of various modifications to the jet configuration which are presented in graphic form. There were three basic model configurations as indicated in the three tables of data: (a) the original model using aileron and spoiler controls, (b) the model with the small plenum chamber and jet controls, (c) the model with the large plenum chamber and jet controls. Each basic configuration had its own no-controls-operating data. The rolling-moment coefficients for the no-controls-operating conditions are not zero and are not the same for all three configurations as a result of model asymmetry and wing modifications.

Lateral-Control Characteristics of Jet Controls

The rolling-moment coefficients C_l of the jet control with small plenum chamber are fairly constant at low angles of attack, are erratic at angles of attack between 6° and 12° , and are considerably reduced at the higher angles of attack as shown in figure 7. This erratic rolling behavior seems to be associated with a wing-dropping phenomenon inherent in the plain-wing model. Increasing the diameter of the jet holes increased the rolling-moment coefficients (fig. 7). The yawing-moment coefficients C_n were small and generally favorable.

The results obtained with larger jet holes in a larger plenum chamber are given in figure 8. The rolling-moment variation with angle of attack is similar to that obtained with the smaller jet holes of the previously discussed configuration, but there is a considerable increase in the magnitude of the rolling-moment coefficients. The yawing moments were generally favorable except at high angles of attack.

There is an increase in rolling-moment coefficient with increase in jet-hole diameter for the large plenum-chamber jet-control configuration as was the case for the smaller plenum-chamber configuration. However, as the ratio of the total exit area of the jet holes to the inlet area into the plenum chamber approaches 1.0 there is only a small increase in rolling-moment coefficient with increase in jet-hole diameter. For example, there is little increase in rolling-moment coefficient with increase in jet-hole diameter between 0.156 to 0.172 (fig. 8) for which the ratios of total exit area to inlet area are approximately 0.90 and 1.10, respectively. With an inlet designed for supersonic speeds there might be an advantage in having jet holes large enough to have a ratio of exit area to inlet area greater than 1.0.

Shorter-span controls starting inboard with 0.125-inch jets and starting at the wing tip with 0.172-inch jets were investigated on the large plenum-chamber jet-control configuration and the results are presented in figure 9. These shorter-span controls were made by sealing 6 jet holes and multiples of 6 holes without other changes to the configuration. The data indicate that, as was found for trailing-edge ailerons over this spanwise location, the rolling-moment coefficients are generally proportional to the span of the control for controls starting either at the tips or the inboard end of the controls.

Comparison of Jet Controls with Ailerons and Spoilers

A comparison of the effectiveness of the jet control with the ailerons of the original model and with trailing-edge spoilers projected 0.052c is given in figure 10. The rolling and yawing moments of the ailerons were opposite in sign to the moments of the spoiler and jet

controls but have been plotted with the same sign for easier visual comparison. The erratic rolling behavior of the model at moderate (between 5° and 12°) angles of attack with all three controls is evident. At small angles of attack the jet control is about 85 percent as effective as the ailerons fully deflected ($\pm 15^\circ$) at a Mach number of 0.60 but becomes more nearly equal as the Mach number increases, and at a Mach number of 0.96 the jet control is about 25 percent more effective than the ailerons. The trailing-edge spoiler is more effective than either the jet or the ailerons at small angles of attack. At angles of attack between 5° and 12° the effectiveness of all three controls decreases, with the jet-control effectiveness decreasing at a faster rate and becoming less effective than either the ailerons or spoilers at high angles of attack. At angles of attack near zero lift ($\alpha = -2$), the jet control has almost constant effectiveness through the Mach number range while both the aileron and spoiler controls show a decrease in effectiveness at $M = 0.96$ (fig. 11). However, all controls retain considerable effectiveness throughout the angle-of-attack and Mach number range investigated. The yawing moments of all controls are favorable in the low angle-of-attack range but become less favorable as the angle of attack increases above 8° or 10° . (See fig. 10.)

Pressures and Weight Flow

Pressures in the large plenum chamber were obtained for all jet-hole diameters and spans investigated. The variation of the ratio of plenum-chamber pressure to tunnel-stagnation pressure with angle of attack is given in figure 12 for the various jet controls. No pressures were obtained for the small plenum-chamber configuration. The pressure ratios of figure 12 show a decrease as the jet diameter or control span increases, as would be expected. There is also a decrease in pressure ratio with increase in angle of attack. This decrease in pressure ratio with angle of attack accounts for some of the decrease in effectiveness of the jet control with angle of attack. Some of the pressure loss in the plenum chamber at high angles of attack might be regained with a better designed inlet thereby increasing the rolling moments by providing a larger quantity of air for the jets.

A knowledge of the actual weight of air used by the jet control would be useful if the air necessary for control were obtained from some other source such as an auxiliary jet engine. Calculated values of weight flow will be only as accurate as the estimated orifice-flow coefficient of the jets. Flow coefficients are obtainable for jets operating under specified conditions but the effect on flow coefficients of the shape of the plenum chamber and the adjacency of the jet holes to each other is unknown. Consequently, the weight-flow values in figure 13 are based on the actual jet diameters without any flow-correction factor. It is roughly estimated that the correct values are 60 to 86 percent of

the values given in figure 13. However, comparisons of the effectiveness of controls of different span and jet diameters based on relative weight flows would probably be as valid as if the comparisons were based on the actual weight flows of air.

The data shown in figure 13 indicate that a control with smaller jet holes and a longer span is more effective per pound of air used than controls with larger jet holes and shorter spans. For instance, the 0.125-inch jets extending from 0.55 to 1.00 semispan and the 0.172-inch jets extending from 0.66 to 1.00 semispan produce approximately equal rolling-moment coefficients but the larger-diameter shorter-span control uses about 35 percent more air. This would be an important point to consider if the air for the controls were furnished by an auxiliary jet engine, but from a structural standpoint on some airplanes it might be better to use controls of shorter span and larger jets if ram air is used for operation.

Drag

It was anticipated that the drag of the model with the jet control would be considerably higher than that of the model with the original ailerons since the jet system was designed primarily to produce roll rather than low drag in this investigation. The drag data are presented in figure 14 and show that not only is the drag greater but most of it is still present when the control is not operating. At low lift coefficients, the model with the nonoperating jet control has drag coefficients about 75 percent greater than the original model with ailerons undeflected (plain wing). Also the model with operating jet control has coefficients 50 to 65 percent greater than the model with ailerons fully deflected. A large part of the drag of the jet control probably could be eliminated if the wing-tip inlets were replaced by an internal duct system taking air from the engine. It is also believed that the drag could be considerably reduced with wing-tip inlets designed for low drag. For the nonoperating condition, the inlets might have exits designed to allow the air to pass directly through with minimum shocks and skin friction drag. A few tests were made to determine whether the excess drag of the jet control could be materially reduced. A faired nose plug in the inlet reduced the excess drag of the nonoperating jet control by 55 to 75 percent as shown in figure 15. In practice the plug might be replaced by an eyelid type of closing device. A considerable part of the excess drag is produced by the thickened trailing edge of the wing at the lower Mach numbers but the thickened trailing edge becomes less objectionable as the Mach number increases.

CONCLUSIONS

A wind-tunnel investigation to determine the characteristics of a jet control operated by ram air and located at the wing trailing edge of a 1/16-scale model of the D-558-II research airplane resulted in the following conclusions:

1. At small angles of attack and at a Mach number of 0.60 the 45-percent-span outboard jet controls are 85 percent as effective as the original ailerons fully deflected, but at a Mach number of 0.96 the jet controls are 25 percent more effective than the ailerons. Trailing-edge spoilers of approximately the same span as the other controls and projecting 0.052 of the wing chord are more effective than the fully deflected ailerons or the jet controls at small angles of attack.

2. At angles of attack near zero lift the jet controls give almost constant control effectiveness through the Mach number range investigated, whereas the effectiveness of the spoilers and the ailerons decreases between Mach numbers 0.90 and 0.96.

3. All three controls decrease in effectiveness at moderate (5° to 12°) angles of attack with the jet control decreasing at a faster rate and becoming less effective than the spoilers or the ailerons at high angles of attack. Some of the decrease in effectiveness of the jet control can be attributed to the loss in pressure ratio in the wing at the higher angles of attack. However, all controls retain considerable effectiveness through the angle-of-attack range investigated.

4. Increasing the jet diameter or increasing the control span increases the rolling-moment coefficients as long as the total jet-exit area does not greatly exceed the inlet area.

5. The drag of the jet control greatly exceeds that of the aileron and was more than that of the spoiler; however, most of the drag results from the installation of the jet system and not from its operation.

Langley Aeronautical Laboratory,
National Advisory Committee for Aeronautics,
Langley Field, Va., May 9, 1956.

REFERENCES

1. Göthert, B.: Effectiveness of a Spoiler at High Subsonic Speeds. Repts. and Translations No. 364, British M.O.S.(A) Völkenrode, 1947.
2. Attinello, John S.: An Air-Jet Spoiler. NAVAER Rep. DR-1579, Bur. Aero., Aug. 1953.
3. Lowry, John G., and Turner, Thomas R.: Low-Speed Wind-Tunnel Investigation of a Jet Control on a 35° Swept Wing. NACA RM L53I09a, 1953.
4. Vogler, Raymond D., and Turner, Thomas R.: Wind-Tunnel Investigation at Transonic Speeds of a Jet Control on a 35° Swept Wing - Transonic-Bump Method. NACA RM L55K09, 1956.
5. Hensel, Rudolph W.: Rectangular-Wind-Tunnel Blocking Corrections Using the Velocity-Ratio Method. NACA TN 2372, 1951.
6. Gillis, Clarence L., Polhamus, Edward C., and Gray, Joseph L., Jr.: Charts for Determining Jet-Boundary Corrections for Complete Models in 7- by 10-Foot Closed Rectangular Wind Tunnels. NACA WR L-123, 1945. (Formerly NACA ARR L5G31.)

TABLE I.- DATA OBTAINED WITH AILERONS AND SPOILERS
ON MODEL WITH ORIGINAL WINGS

Plain wing							Trailing-edge spoilers projecting 0.052c.						
<i>a</i>	<i>C_L</i>	<i>C_D</i>	<i>C_m</i>	<i>C_i</i>	<i>C_n</i>	<i>C_y</i>	<i>a</i>	<i>C_L</i>	<i>C_D</i>	<i>C_m</i>	<i>C_i</i>	<i>C_n</i>	<i>C_y</i>
<i>M = 0.60</i>							<i>M = 0.60</i>						
-4.09	-.1593	.0218	.0935	-.0005	.0001	.0102	-4.09	-.1679	.0405	.1095	-.0355	-.0062	.0146
-1.97	-.0028	.0180	.0568	-.0004	.0000	.0091	-1.96	-.0049	.0364	.0680	-.0356	-.0061	.0152
0.15	.1568	.0202	.0237	-.0003	.0001	.0086	0.16	.1575	.0369	.0293	-.0356	-.0051	.0144
2.28	.3158	.0279	-.0048	-.0007	.0001	.0067	2.28	.3366	.0436	-.0091	-.0339	-.0042	.0155
4.40	.4747	.0459	-.0342	-.0006	-.0004	.0046	4.43	.5112	.0641	-.0456	-.0324	-.0039	.0147
6.53	.6347	.0878	-.0667	-.0031	-.0019	.0097	6.57	.7011	.1068	-.1001	-.0285	-.0028	.0119
8.64	.7244	.1365	-.0243	-.0016	-.0001	.0125	8.68	.8244	.1612	-.1145	-.0266	.0005	.0061
10.68	.7663	.1834	-.0445	-.0016	-.0004	.0045	10.72	.8530	.2084	-.0894	-.0245	.0019	.0041
12.71	.7837	.2241	-.0169	-.0009	-.0004	.0044	12.76	.8603	.2497	-.0613	-.0207	.0015	.0020
14.72	.7989	.2625	-.0279	-.0006	-.0004	.0052	14.77	.8746	.2913	-.0674	-.0187	.0015	.0014
16.75	.8306	.3050	-.0601	-.0016	.0000	.0055	16.81	.9082	.3372	-.0978	-.0196	.0024	-.0019
18.81	.8995	.3644	-.0896	-.0026	.0005	.0027	18.84	.9626	.3931	-.1255	-.0210	.0037	-.0046
20.83	.9397	.4143	-.1174	-.0048	.0029	.0000	20.57	.6771	.3195	-.1542	-.0229	.0045	-.0114
<i>M = 0.80</i>							<i>M = 0.80</i>						
-4.13	-.1718	.0201	.1080	-.0007	.0001	.0040	-4.13	-.1823	.0398	.1214	-.0343	-.0053	.0155
-1.93	.0079	.0163	.0678	-.0007	.0000	.0048	-1.92	.0062	.0382	.0793	-.0342	-.0052	.0162
0.27	.1870	.0194	.0338	-.0007	-.0003	.0036	0.28	.1970	.0373	.0361	-.0333	-.0045	.0155
2.49	.3824	.0322	-.0027	-.0007	-.0002	.0037	2.51	.3921	.0487	-.0034	-.0327	-.0041	.0153
4.71	.5766	.0652	-.0411	-.0010	-.0004	.0034	4.73	.6117	.0809	-.0628	-.0292	-.0033	.0140
6.84	.6773	.1092	-.0543	.0014	.0004	.0030	6.93	.7762	.1328	-.0988	-.0265	-.0003	.0090
8.91	.7316	.1540	-.0479	-.0092	-.0014	.0082	8.96	.7854	.1733	-.0868	-.0248	.0006	.0056
10.94	.7267	.1899	-.0201	-.0011	-.0003	.0039	11.01	.8055	.2142	-.0665	-.0211	.0006	.0059
13.00	.7617	.2343	-.0295	-.0018	-.0003	.0032	13.05	.8372	.2585	-.0716	-.0219	.0009	.0005
15.03	.7943	.2755	-.0512	-.0024	.0001	.0009	15.07	.8580	.2994	-.0949	-.0210	.0011	-.0022
17.10	.8590	.3284	-.0797	-.0034	.0019	-.0016	17.14	.9083	.3508	-.1209	-.0212	.0021	-.0048
19.19	.9235	.3880	-.1081	-.0035	.0023	-.0044	19.22	.9736	.4121	-.1476	-.0221	.0033	-.0072
21.23	.9590	.4382	-.1305	-.0043	.0029	-.0040	21.31	1.0311	.4764	-.1748	-.0224	.0054	-.0096
<i>M = 0.85</i>							<i>M = 0.85</i>						
-4.15	-.1923	.0210	.1193	.0000	.0005	.0009	-4.14	-.1914	.0389	.1330	-.0335	-.0050	.0143
-1.94	-.0045	.0166	.0754	.0001	.0004	.0010	-1.92	.0091	.0341	.0840	-.0335	-.0048	.0164
0.30	.1958	.0204	.0402	.0000	.0001	.0011	0.33	.2088	.0379	.0437	-.0332	-.0047	.0148
2.56	.4095	.0373	-.0030	-.0003	-.0002	.0027	2.58	.4312	.0540	-.0069	-.0318	-.0045	.0157
4.78	.5945	.0762	-.0444	-.0007	-.0006	.0018	4.85	.6621	.0930	-.0814	-.0299	-.0039	.0135
6.89	.6698	.1149	-.0443	.0013	.0004	.0015	6.99	.7729	.1374	-.1015	-.0259	-.0007	.0076
8.95	.7011	.1582	-.0290	-.0004	.0001	.0002	9.02	.7780	.1770	-.0835	-.0247	.0006	.0042
11.01	.7325	.1948	-.0176	-.0010	.0000	-.0004	11.07	.8010	.2164	-.0690	-.0207	.0009	.0027
13.08	.7759	.2393	-.0293	-.0021	.0006	.0048	13.12	.8345	.2608	-.0784	-.0219	.0011	-.0004
15.12	.8094	.2811	-.0530	-.0028	.0013	-.0038	15.16	.8679	.3061	-.1007	-.0209	.0013	-.0008
17.19	.8703	.3361	-.0871	-.0037	.0037	-.0070	17.24	.9325	.3645	-.1330	-.0209	.0023	-.0036
19.29	.9422	.3989	-.1169	-.0031	.0036	-.0075	19.34	1.0017	.4295	-.1613	-.0218	.0041	-.0061
21.37	1.0023	.4617	-.1412	-.0038	.0039	-.0073	21.43	1.0678	.4995	-.1907	-.0223	.0057	-.0076
<i>M = 0.90</i>							<i>M = 0.90</i>						
-4.19	-.2156	.0233	.1392	-.0003	.0004	.0039	-4.18	-.2236	.0430	.1576	-.0329	-.0044	.0172
-1.92	.0032	.0177	.0866	-.0003	.0003	.0030	-1.90	.0074	.0357	.0968	-.0326	-.0048	.0178
0.37	.2389	.0269	.0243	-.0002	.0003	.0034	0.38	.2471	.0452	.0247	-.0319	-.0044	.0170
2.61	.4441	.0515	-.0327	-.0004	.0000	.0017	2.68	.5037	.0716	-.0671	-.0297	-.0031	.0137
4.82	.6001	.0877	-.0571	-.0004	.0001	.0014	4.86	.6693	.1086	-.1297	-.0349	-.0023	.0132
6.95	.6785	.1228	-.0488	.0006	.0004	.0010	7.05	.7839	.1503	-.1132	-.0264	-.0008	.0090
9.01	.6997	.1602	-.0295	-.0004	.0004	.0026	9.09	.7891	.1863	-.0836	-.0210	.0008	.0039
11.10	.7494	.2028	-.0273	-.0005	.0000	.0011	11.17	.8297	.2294	-.0748	-.0200	.0009	.0022
13.21	.8172	.2535	-.0397	-.0018	.0003	.0012	13.31	.9167	.2927	-.0883	-.0191	.0009	.0015
15.27	.8754	.3072	-.0628	-.0024	.0009	-.0005	15.35	.9458	.3390	-.1089	-.0197	.0012	-.0019
17.37	.9439	.3676	-.0991	-.0023	.0009	-.0020	17.40	.9934	.3939	-.1452	-.0194	.0025	-.0035
19.44	1.0009	.4287	-.1361	-.0035	.0019	-.0059	19.51	1.0725	.4672	-.1875	-.0199	.0040	-.0066
21.55	1.0744	.5006	-.1659	-.0039	.0031	-.0063	21.55	1.0949	.5175	-.2038	-.0207	.0054	-.0070
<i>M = 0.96</i>							<i>M = 0.96</i>						
-4.15	-.1997	.0424	.1620	-.0005	.0010	.0033	-4.15	-.2116	.0577	.1791	-.0303	-.0018	.0100
-1.91	-.0055	.0377	.0966	-.0014	.0007	.0047	-1.90	.0072	.0510	.0914	-.0291	-.0020	.0117
0.35	.2086	.0440	.0226	.018-	-.0002	.0051	0.37	.2408	.0633	-.0021	-.0292	-.0010	.0098
2.60	.4181	.0691	-.0485	.0001	-.0001	.0036	2.63	.4660	.0904	-.0863	-.0289	.0013	.1163
4.87	.6199	.1074	-.0995	-.0003	.0000	.0025	4.90	.6760	.1287	-.1519	-.0248	.0000	.0060
7.03	.7285	.1440	-.1020	.0000	.0001	.0033	7.10	.8073	.1694	-.1569	-.0241	.0006	.0059
9.24	.8851	.2111	-.1477	.0008	.0001	-.0009	9.20	.8447	.2041	-.1301	-.0198	.0012	.0002
11.40	.9505	.2658	-.1146	.0013	-.0002	-.0013	11.48	1.0839	.3112	-.2447	-.0157	.0017	-.0035
13.50	.9937	.3197	-.0895	-.0012	-.0003	.0004	13.58	1.0831	.3601	-.1956	-.0160	.0020	-.0023

TABLE I.- DATA OBTAINED WITH AILERONS AND SPOILERS
ON MODEL WITH ORIGINAL WINGS - Concluded

Ailerons deflected equally and oppositely 7.5° each.							Ailerons deflected equally and oppositely 15° each.						
α	C_L	C_D	C_m	C_l	C_n	C_y	α	C_L	C_D	C_m	C_l	C_n	C_y
M = 0.60							M = 0.60						
-4.09	-.1610	.0228	.0983	.0172	.0024	-.0046	-4.09	-.1689	.0283	.1006	.0311	.0046	-.0159
-1.97	.0013	.0186	.0602	.0173	.0028	-.0042	-1.98	-.0067	.0244	.0607	.0316	.0044	-.0173
0.15	.1442	.0185	.0305	.0171	.0025	-.0060	0.15	.1473	.0259	.0317	.0307	.0042	-.0155
2.27	.3053	.0283	-.0022	.0161	.0022	-.0066	2.27	.3083	.0330	-.0001	.0295	.0041	-.0159
4.40	.4767	.0478	-.0330	.0156	.0014	-.0068	4.43	.5116	.0543	-.0310	.0286	.0036	-.0138
6.54	.6347	.0873	-.0614	.0118	-.0007	-.0012	6.53	.6349	.0880	-.0629	.0266	.0026	-.0128
8.60	.7238	.1362	-.0635	.0093	.0000	-.0004	8.60	.7268	.1404	-.0647	.0210	.0010	-.0103
10.66	.7521	.1807	-.0393	.0071	.0001	-.0023	10.66	.7533	.1819	-.0398	.0204	.0007	-.0099
12.70	.7742	.2216	-.0107	.0102	.0003	-.0029	12.75	.7677	.2243	.0046	.0193	.0018	-.0050
14.71	.7834	.2573	-.0207	.0116	-.0005	-.0041	14.71	.7861	.2641	-.0228	.0221	-.0005	-.0044
16.74	.8261	.3040	-.0549	.0117	-.0003	-.0061	16.73	.8150	.3049	-.0546	.0212	-.0006	-.0068
18.78	.8761	.3539	-.0804	.0097	.0003	-.0083	18.77	.8680	.3566	-.0791	.0185	.0002	-.0083
20.83	.9398	.4128	-.1114	.0066	.0033	-.0110	20.84	.9447	.4210	-.1073	.0152	.0030	-.0106
M = 0.80							M = 0.80						
-4.14	-.1818	.0215	.1110	.0177	.0025	-.0075	-4.14	-.1841	.0284	.1156	.0307	.0050	-.0119
-1.94	-.0002	.0172	.0734	.0176	.0023	-.0090	-1.94	-.0023	.0294	.0749	.0303	.0047	-.0125
0.26	.1810	.0206	.0382	.0170	.0022	-.0076	0.25	.1788	.0249	.0396	.0293	.0044	-.0125
2.47	.3463	.0325	.0005	.0157	.0022	-.0091	2.48	.3765	.0373	.0023	.0276	.0042	-.0113
4.68	.5383	.0427	-.0345	.0154	.0023	-.0105	4.69	.5688	.0677	-.0384	.0277	.0042	-.0118
6.81	.6649	.1064	-.0491	.0147	.0017	-.0071	6.84	.6841	.1139	-.0501	.0248	.0032	-.0096
8.88	.7023	.1510	-.0346	.0121	.0007	-.0063	8.90	.7237	.1564	-.0392	.0186	.0016	-.0060
10.92	.7125	.1871	-.0159	.0114	.0008	-.0064	10.93	.7257	.1955	-.0095	.0204	.0023	-.0068
12.98	.7309	.2296	-.0171	.0118	.0008	-.0074	12.96	.7410	.2337	-.0097	.0233	.0024	-.0066
14.99	.7677	.2644	-.0493	.0141	-.0004	-.0074	14.99	.7580	.2693	-.0414	.0248	.0002	-.0060
17.06	.8340	.3193	-.0756	.0135	-.0012	-.0140	17.06	.8292	.3246	-.0684	.0243	-.0010	-.0060
19.14	.8946	.3749	-.1003	.0113	.0001	-.0162	19.13	.8966	.3830	-.0956	.0221	.0003	-.0051
21.23	.9593	.4374	-.1236	.0101	.0019	-.0113	21.23	.9648	.4470	-.1192	.0193	.0021	-.0109
M = 0.85							M = 0.85						
-4.17	-.2048	.0221	.1227	.0176	.0025	-.0100	-4.15	-.1973	.0270	.1253	.0295	.0049	-.0104
-1.95	-.0141	.0170	.0788	.0176	.0023	-.0098	-1.92	.0109	.0219	.0776	.0295	.0047	-.0118
0.28	.1803	.0208	.0407	.0175	.0022	-.0114	0.28	.2045	.0267	.0425	.0295	.0045	-.0168
2.52	.3833	.0345	-.0005	.0162	.0021	-.0108	2.58	.4297	.0444	-.0046	.0274	.0044	-.0118
4.75	.5847	.0730	-.0463	.0153	.0021	-.0120	4.79	.6130	.0817	-.0311	.0282	.0032	-.0132
6.88	.6696	.1158	-.0464	.0145	.0017	-.0112	6.90	.6925	.1216	-.0520	.0226	.0031	-.0091
8.94	.6938	.1549	-.0282	.0153	.0015	-.0086	8.96	.7068	.1623	-.0286	.0237	.0030	-.0085
11.01	.7329	.1971	-.0142	.0112	.0011	-.0077	11.06	.7624	.2109	-.0193	.0193	.0031	-.0059
13.05	.7551	.2350	-.0261	.0111	.0016	-.0093	13.06	.7633	.2441	-.0172	.0218	.0029	-.0064
15.10	.8050	.2825	-.0536	.0140	-.0004	-.0070	15.10	.8044	.2891	-.0519	.0239	-.0003	-.0063
17.16	.8597	.3315	-.0829	.0135	-.0010	-.0077	17.16	.8351	.3386	-.0811	.0238	-.0015	-.0027
19.23	.9112	.3873	-.1125	.0113	-.0003	-.0106	19.26	.8970	.3996	-.1090	.0211	-.0003	-.0039
21.34	.9883	.4570	-.1360	.0099	.0014	-.0123	21.36	.9987	.4687	-.1320	.0190	.0019	-.0069
M = 0.90							M = 0.90						
-4.21	-.2398	.0259	.1428	.0174	.0024	-.0099	-4.19	-.2204	.0306	.1445	.0288	.0046	-.0081
-1.92	-.0012	.0190	.0830	.0171	.0019	-.0112	-1.91	.0096	.0245	.0888	.0285	.0046	-.0106
0.36	.2249	.0274	.0272	.0167	.0018	-.0104	0.29	.1939	.0333	.0283	.0287	.0040	-.0094
2.59	.4320	.0511	-.0281	.0141	.0021	-.0105	2.47	.4603	.0565	-.0281	.0228	.0034	-.0282
4.79	.5824	.0859	-.0595	.0144	.0014	-.0090	4.84	.6271	.0962	-.0702	.0254	.0036	-.0079
6.92	.6664	.1205	-.0499	.0133	.0012	-.0098	6.96	.6965	.1319	-.0541	.0233	.0034	-.0064
9.01	.7031	.1631	-.0297	.0124	.0013	-.0075	9.01	.7122	.1699	-.0275	.0183	.0026	-.0061
11.08	.7449	.2039	-.0221	.0109	.0013	-.0077	11.13	.7947	.2222	-.0332	.0171	.0027	-.0027
13.18	.8094	.2546	-.0299	.0099	.0019	-.0102	13.21	.8296	.2673	-.0277	.0168	.0030	-.0039
15.29	.8889	.3164	-.0618	.0099	.0013	-.0099	15.24	.8637	.3125	-.0600	.0213	-.0002	-.0013
17.31	.9154	.3603	-.0945	.0110	.0002	-.0080	17.31	.9133	.3664	-.0937	.0213	-.0010	-.0013
19.37	.9600	.4130	-.1287	.0102	-.0008	-.0083	19.40	.9798	.4297	-.1289	.0190	-.0012	-.0056
21.49	1.0411	.4887	-.1564	.0079	.0014	-.0117	21.53	1.0604	.5040	-.1591	.0160	.0013	-.0021
M = 0.96							M = 0.96						
-4.19	-.2234	.0436	.1634	.0110	.0013	-.0038	-4.17	-.2132	.0490	.1638	.0194	.0027	-.0031
-1.93	-.0144	.0368	.0945	.0103	.0008	-.0046	-1.90	.0084	.0493	.0882	.0194	.0028	-.0017
0.32	.1987	.0468	.0194	.0094	-.0001	-.0043	0.28	.1816	.0361	.0129	.0173	.0008	-.0007
2.57	.4068	.0717	-.0510	.0113	.0000	-.0066	2.59	.4290	.0729	-.0545	.0172	.0009	-.0023
4.82	.5964	.1042	-.0881	.0182	.0003	-.0030	4.83	.6183	.1183	-.1109	.0285	.0007	-.0021
7.00	.7083	.1430	-.0862	.0108	.0002	-.0036	7.05	.7508	.1580	-.1284	.0179	.0011	-.0027
9.19	.7984	.1891	-.0951	.0118	.0003	-.0002	9.13	.8021	.1953	-.1216	.0154	.0016	-.0027
11.39	.9661	.2678	-.1279	.0080	-.0003	-.0018	11.33	.9489	.2711	-.1631	.0148	.0003	-.0043
13.58	1.0670	.3466	-.1253	.0074	-.0012	-.0049	13.54	1.0488	.3473	-.1271	.0138	-.0006	-.0010

TABLE II.- DATA OBTAINED WITH JET CONTROLS INCLUDING WING-TIP
INLETS AND SMALL PLENUM CHAMBER IN WINGS

Jets closed.							Thirty-nine 0.063-inch-diameter jets open.						
α	C_L	C_D	C_m	C_i	C_n	C_y	α	C_L	C_D	C_m	C_i	C_n	C_y
<i>M = 0.60</i>							<i>M = 0.60</i>						
-4.10	-0.2005	0.0388	.1196	-.0027	-.0006	.0012	-4.11	-0.2030	0.0398	.1201	-.0123	-.0024	.0068
-1.98	-.0217	0.0329	.0688	-.0028	-.0010	-.0014	-1.98	-.0204	0.0343	0.0692	-.0128	-.0024	.0082
0.15	.1586	0.0360	0.253	-.0029	-.0013	-.0031	0.15	.1584	0.0373	0.247	-.0127	-.0025	.0043
2.28	0.3350	0.0476	-.0284	-.0028	-.0012	-.0059	2.30	0.3438	0.0487	-.0283	-.0121	-.0025	.0043
4.43	0.5190	0.0714	-.0683	-.0024	-.0011	-.0047	4.42	0.5177	0.0723	-.0648	-.0117	-.0024	.0028
6.54	0.7793	0.1130	-.0983	-.0022	-.0014	-.0053	6.54	0.7751	0.1164	-.1034	-.0100	-.0022	.0016
8.64	0.7784	0.1649	-.1077	-.0029	-.0017	-.0115	8.64	0.7812	0.1674	-.1129	-.0108	-.0023	.0015
10.69	0.8096	0.2120	-.0662	-.0029	-.0011	-.0002	10.71	0.8232	0.2170	-.0814	-.0105	-.0029	-.0038
12.74	0.8397	0.2607	-.0314	-.0024	-.0014	-.0073	12.74	0.8504	0.2634	-.0844	-.0086	-.0030	.0030
14.75	0.8571	0.3022	-.0680	-.0023	-.0014	-.0072	14.75	0.8715	0.3078	-.0845	-.0071	-.0015	-.0052
16.79	0.9076	0.3531	-.1023	-.0038	-.0006	-.0089	16.80	0.9147	0.3573	-.1133	-.0085	-.0005	-.0045
18.85	0.9689	0.4125	-.1338	-.0043	-.0001	-.0120	18.83	0.9630	0.4101	-.1432	-.0097	0.0000	-.0074
20.88	1.0104	0.4670	-.1608	-.0061	0.0017	-.0146	20.88	1.0143	0.4708	-.1711	-.0110	0.0011	-.0101
<i>M = 0.80</i>							<i>M = 0.80</i>						
-4.18	-0.2222	0.0399	.1395	-.0029	-.0008	-.0060	-4.18	-0.2297	0.0488	.1407	-.0130	-.0019	.0019
-1.95	-.0168	0.0337	0.0804	-.0025	-.0011	-.0060	-1.96	-.0120	0.0344	0.0777	-.0130	-.0019	.0029
0.26	.1926	0.0382	0.254	-.0030	-.0012	-.0054	0.26	.1928	0.0403	0.239	-.0128	-.0021	.0024
2.48	0.3918	0.0550	-.0235	-.0030	-.0014	-.0059	2.50	0.4090	0.0581	-.0283	-.0131	-.0022	.0044
4.69	0.5823	0.0879	-.0690	-.0029	-.0020	-.0029	4.70	0.5975	0.0920	-.0749	-.0127	-.0027	.0055
6.86	0.7152	0.1345	-.0747	-.0035	-.0022	-.0022	6.85	0.7270	0.1390	-.1004	-.0117	-.0023	.0039
8.96	0.7826	0.1868	-.0772	-.0034	-.0009	-.0082	8.97	0.8026	0.1922	-.0931	-.0053	-.0003	-.0034
11.00	0.7964	0.2292	-.0596	-.0019	-.0013	-.0071	11.00	0.8065	0.2329	-.0749	-.0076	-.0017	.0003
13.06	0.8437	0.2803	-.0705	-.0040	-.0013	-.0105	13.05	0.8402	0.2779	-.0827	-.0096	-.0014	-.0018
15.10	0.8802	0.3254	-.1010	-.0044	-.0010	-.0099	15.11	0.8945	0.3315	-.1169	-.0097	-.0008	-.0012
17.18	0.9432	0.3859	-.1396	-.0049	-.0005	-.0126	17.17	0.9355	0.3899	-.1332	-.0107	-.0001	-.0023
19.23	1.0030	0.4440	-.1814	-.0057	0.0003	-.0132	19.24	1.0179	0.4313	-.2011	-.0101	-.0007	-.0023
21.33	1.0749	0.5171	-.2155	-.0058	0.0027	-.0203	21.33	1.0819	0.5203	-.2198	-.0112	0.0028	-.0141
<i>M = 0.85</i>							<i>M = 0.85</i>						
-4.18	-0.2262	0.0392	.1444	-.0040	-.0004	-.0052	-4.20	-0.2369	0.0422	.1514	-.0133	-.0020	.0017
-1.95	-.0119	0.0344	0.0788	-.0039	-.0004	-.0038	-1.94	-.0074	0.0320	0.0807	-.0129	-.0021	.0038
0.32	.2194	0.0421	0.2028	-.0034	-.0008	-.0037	0.33	.2258	0.0402	0.186	-.0134	-.0025	.0057
2.57	0.4365	0.0627	-.0383	-.0033	-.0008	-.0059	2.58	0.4378	0.0692	-.0483	-.0139	-.0023	.0048
4.79	0.6200	0.0991	-.0803	-.0046	-.0023	-.0015	4.81	0.6455	0.1015	-.0921	-.0143	-.0034	.0045
6.99	0.7483	0.1461	-.0993	-.0038	-.0011	-.0049	6.97	0.7738	0.1516	-.1108	-.0121	-.0020	.0037
9.01	0.7724	0.1890	-.0792	-.0049	-.0008	-.0031	9.05	0.8096	0.1955	-.0943	-.0108	-.0016	.0039
11.08	0.8190	0.2381	-.0734	-.0043	-.0003	-.0070	11.11	0.8352	0.2411	-.0837	-.0089	-.0016	.0019
13.15	0.8610	0.2870	-.0791	-.0043	-.0003	-.0069	13.15	0.8726	0.2876	-.0984	-.0098	-.0013	-.0007
15.22	0.9153	0.3406	-.1181	-.0049	-.0002	-.0050	15.23	0.9350	0.3449	-.1377	-.0097	-.0009	-.0013
17.27	0.9687	0.3973	-.1605	-.0054	0.0009	-.0072	17.30	1.0026	0.4101	-.1811	-.0097	-.0003	-.0035
19.36	1.0389	0.4652	-.2039	-.0054	0.0011	-.0094	19.37	1.0584	0.4698	-.2215	-.0093	0.0000	-.0080
21.45	1.1108	0.5386	-.2375	-.0093	0.0058	-.0158	21.48	1.1318	0.5460	-.2467	-.0161	0.0058	-.0106
<i>M = 0.90</i>							<i>M = 0.90</i>						
-4.21	-0.2610	0.0468	.1795	-.0039	-.0001	-.0009	-4.20	-0.2370	0.0466	.1875	-.0131	-.0014	.0020
-1.92	-.0055	0.0397	0.0922	-.0033	-.0005	0.0012	-1.92	0.0044	0.0364	0.0877	-.0134	-.0020	.0029
0.36	.2385	0.0474	0.0075	-.0037	-.0007	0.0022	0.37	.2671	0.0491	-.0023	-.0138	-.0022	.0034
2.60	0.4486	0.0741	-.0524	-.0031	-.0007	-.0022	2.62	0.4732	0.0764	-.0643	-.0123	-.0021	.0032
4.84	0.6345	0.1128	-.0965	-.0040	-.0016	-.0001	4.86	0.6586	0.1182	-.1084	-.0147	-.0031	.0042
7.03	0.7697	0.1598	-.1097	-.0030	-.0011	-.0025	7.03	0.7747	0.1583	-.1185	-.0121	-.0024	.0009
9.12	0.8210	0.2074	-.0916	-.0089	-.0014	-.0007	9.13	0.8276	0.2074	-.1028	-.0121	-.0023	-.0010
11.20	0.8495	0.2518	-.0797	-.0028	-.0005	-.0046	11.21	0.8739	0.2544	-.0995	-.0089	-.0015	-.0034
13.30	0.9096	0.3054	-.0864	-.0035	-.0002	-.0049	13.31	0.9339	0.3118	-.1105	-.0094	-.0010	-.0040
15.36	0.9672	0.3631	-.1298	-.0045	-.0001	-.0059	15.41	1.0181	0.3797	-.1487	-.0099	-.0004	-.0078
17.43	1.0360	0.4297	-.1891	-.0053	0.0007	-.0104	17.46	1.0647	0.4389	-.2058	-.0104	0.0009	-.0110
19.51	1.0999	0.4965	-.2273	-.0055	0.0015	-.0109	19.53	1.1326	0.5085	-.2551	-.0127	0.0022	-.0130
21.62	1.1767	0.5773	-.2741	-.0090	0.0044	-.0146	21.65	1.2050	0.5899	-.2908	-.0151	0.0053	-.0173
<i>M = 0.96</i>							<i>M = 0.96</i>						
-4.18	-0.2357	0.0665	.1922	-.0027	0.0003	-.0056	-4.17	-0.2319	0.0601	.1900	-.0135	-.0008	.0038
-1.91	-.0057	0.0360	0.0995	-.0034	-.0004	-.0038	-1.91	0.0021	0.0359	0.0927	-.0131	-.0012	.0030
0.37	.2340	0.0639	0.0070	-.0038	-.0013	-.0023	0.34	.2370	0.0700	-.0075	-.0148	-.0018	.0054
2.62	0.4417	0.0924	-.0619	-.0014	-.0009	-.0034	2.57	0.4144	0.0880	-.0641	-.0130	-.0016	.0044
4.84	0.6169	0.1299	-.1210	-.0018	-.0012	-.0092	4.84	0.6293	0.1268	-.1194	-.0099	-.0015	.0020
7.11	0.8378	0.1936	-.1594	-.0038	-.0013	-.0100	7.10	0.8209	0.1854	-.1833	-.0098	-.0015	.0012
9.37	1.0238	0.2676	-.2369	-.0057	-.0012	-.0089	9.35	1.0315	0.2741	-.2784	-.0127	0.0016	-.0036
11.47	1.0908	0.3272	-.2572	-.0042	-.0014	-.0107	11.53	1.1561	0.3457	-.2988	-.0121	-.0019	.0039
13.66	1.1897	0.4106	-.2516	-.0006	-.0018	-.0120							

TABLE II.- DATA OBTAINED WITH JET CONTROLS INCLUDING WING-TIP
INLETS AND SMALL PLENUM CHAMBER IN WINGS - Concluded

Thirty-nine 0.081-inch-diameter jets open.							Thirty-nine 0.099-inch-diameter jets open.						
<i>a</i>	<i>C_L</i>	<i>C_D</i>	<i>C_m</i>	<i>C_i</i>	<i>C_n</i>	<i>C_y</i>	<i>a</i>	<i>C_L</i>	<i>C_D</i>	<i>C_m</i>	<i>C_i</i>	<i>C_n</i>	<i>C_y</i>
<i>M = 0.60</i>							<i>M = 0.60</i>						
-4.11	-.1995	.0410	.1174	-.0155	-.0027	.0065	-4.10	-.1997	.0409	.1192	-.0164	-.0024	.0144
-1.98	-.0210	.0357	.0685	-.0154	-.0028	.0081	-1.98	-.0174	.0365	.0685	-.0160	-.0025	.0140
0.15	.1574	.0393	.0224	-.0156	-.0029	.0139	0.16	.1678	.0398	.0222	-.0167	-.0023	.0180
2.30	.3422	.0510	-.0245	-.0148	-.0025	.0119	2.30	.3458	.0511	-.0236	-.0161	-.0024	.0160
4.43	.5217	.0760	-.0681	-.0147	-.0030	-.0012	4.43	.5298	.0765	-.0672	-.0158	-.0027	.0143
6.56	.6900	.1201	-.1063	-.0132	-.0027	.0130	6.55	.6867	.1196	-.1057	-.0149	-.0025	.0131
8.65	.7852	.1710	-.1137	-.0139	-.0026	.0129	8.64	.7788	.1699	-.1159	-.0149	-.0025	.0128
10.70	.8234	.2189	-.0878	-.0123	-.0009	.0074	10.69	.8205	.2177	-.0880	-.0128	-.0005	.0059
12.74	.8514	.2649	-.0707	-.0085	-.0009	.0081	12.74	.8521	.2646	-.0726	-.0089	-.0008	.0020
14.76	.8790	.3107	-.0890	-.0076	-.0009	.0061	14.78	.8857	.3143	-.0930	-.0090	-.0010	-.0002
16.80	.9215	.3607	-.1198	-.0102	-.0001	.0048	16.80	.9248	.3628	-.1219	-.0113	.0005	-.0012
18.85	.9820	.4199	-.1475	-.0111	.0010	.0022	18.85	.9792	.4186	-.1478	-.0120	.0011	-.0037
20.90	1.0335	.4796	-.1781	-.0124	.0024	-.0008	20.89	1.0241	.4753	-.1803	-.0136	.0027	-.0090
<i>M = 0.80</i>							<i>M = 0.80</i>						
-4.19	-.2291	.0425	.1386	-.0154	-.0022	.0069	-4.17	-.2161	.0410	.1392	-.0171	-.0024	.0005
-1.96	-.0120	.0360	.0745	-.0149	-.0024	.0093	-1.95	-.0059	.0358	.0770	-.0168	-.0024	.0015
0.42	.3156	.0431	.0229	-.0156	-.0027	.0113	0.29	.2059	.0426	.0221	-.0171	-.0029	.0020
2.50	.4129	.0598	-.0323	-.0152	-.0029	.0118	2.50	.4098	.0594	-.0295	-.0167	-.0028	.0029
4.70	.5977	.0925	-.0795	-.0151	-.0031	.0130	4.70	.6052	.0943	-.0804	-.0161	-.0032	.0024
6.86	.7293	.1402	-.1028	-.0131	-.0026	.0115	6.89	.7510	.1454	-.1037	-.0140	-.0024	.0011
8.98	.8124	.1932	-.1017	-.0059	-.0001	.0023	8.97	.8080	.1939	-.1029	-.0083	-.0007	-.0072
11.00	.8132	.2346	-.0798	-.0089	-.0018	.0050	11.00	.8116	.2349	-.0833	-.0106	-.0020	-.0047
13.07	.8535	.2822	-.0900	-.0108	-.0012	.0030	13.07	.8636	.2863	-.0954	-.0120	-.0014	-.0048
15.12	.9027	.3347	-.1249	-.0113	-.0010	.0005	15.12	.8993	.3331	-.1234	-.0121	-.0012	-.0006
17.05	.9596	.3882	-.3122	-.0118	-.0007	-.0206	17.18	.9671	.3939	-.1671	-.0135	-.0001	-.0093
19.23	1.0119	.4493	-.2038	-.0117	-.0013	-.0017	19.22	1.0108	.4494	-.2074	-.0129	-.0009	-.0114
21.33	1.0823	.5197	-.2256	-.0131	.0035	-.0148	21.33	1.0889	.5201	-.2293	-.0143	.0037	-.0244
<i>M = 0.85</i>							<i>M = 0.85</i>						
-4.19	-.2331	.0419	.1499	-.0157	-.0022	.0027	-4.19	-.2317	.0430	.1509	-.0178	-.0022	.0066
-1.93	-.0012	.0355	.0757	-.0158	-.0023	.0032	-1.95	-.0109	.0365	.0830	-.0177	-.0021	.0077
0.31	.2116	.0430	.0205	-.0163	-.0030	.0045	0.33	.2250	.0449	.0174	-.0176	-.0024	.0105
2.58	.4573	.0673	-.0490	-.0166	-.0030	.0044	2.59	.4711	.0706	-.0523	-.0183	-.0029	.0127
4.81	.6450	.1055	-.0954	-.0169	-.0039	.0065	4.81	.6477	.1061	-.0958	-.0186	-.0038	.0126
6.96	.7619	.1514	-.1126	-.0157	-.0030	.0032	6.95	.7541	.1503	-.1129	-.0166	-.0026	.0106
9.05	.8151	.1984	-.1056	-.0077	-.0015	-.0049	9.04	.8137	.2001	-.1089	-.0095	-.0011	.0045
11.10	.8377	.2446	-.0940	-.0077	-.0018	-.0031	11.10	.8419	.2444	-.0920	-.0123	-.0018	.0059
13.16	.8800	.2938	-.1062	-.0116	-.0012	-.0077	13.15	.8791	.2934	-.1095	-.0131	-.0009	.0018
15.23	.9395	.3513	-.1439	-.0122	-.0008	-.0081	15.23	.9432	.3522	-.1443	-.0134	-.0012	.0017
17.30	1.0016	.4108	-.1844	-.0122	-.0004	-.0125	17.28	.9943	.4095	-.1878	-.0139	.0000	.0005
19.37	1.0490	.4693	-.2188	-.0106	-.0014	-.0165	19.37	1.0420	.4760	-.223-	-.0122	-.0001	-.0068
21.46	1.1266	.5471	-.2573	-.0167	.0060	-.0231	21.45	1.1205	.5448	-.234-	-.0167	.0059	-.0166
<i>M = 0.90</i>							<i>M = 0.90</i>						
-4.21	-.2573	.0483	.1801	-.0162	-.0021	.0025	-4.20	-.2554	.0490	.1801	-.0173	-.0018	.0107
-1.92	-.0023	.0403	.0874	-.0161	-.0022	.0039	-1.92	-.0002	.0414	.0872	-.0177	-.0020	.0132
0.37	.2920	.0515	.0000	-.0166	-.0026	.0070	0.38	.2647	.0365	-.0002	-.0180	-.0029	.0129
2.61	.4728	.0802	-.0707	-.0157	-.0029	.0060	2.58	.4778	.0811	-.1255	-.0172	-.0027	.0058
4.85	.6481	.1173	-.1118	-.0170	-.0035	.0060	4.85	.6503	.1202	-.1120	-.0180	-.0029	.0130
7.03	.7786	.1635	-.1251	-.0154	-.0033	.0034	7.04	.7908	.1682	-.1312	-.0185	-.0032	.0109
9.13	.8313	.2121	-.1088	-.0150	-.0027	.0004	9.14	.8439	.2158	-.1146	-.0169	-.0021	.0070
11.20	.8738	.2595	-.1026	-.0107	-.0016	-.0019	11.21	.8763	.2617	-.1083	-.0118	-.0011	.0037
13.30	.9359	.3157	-.1218	-.0110	-.0013	-.0043	13.29	.9267	.3131	-.1221	-.0123	-.0011	.0025
15.36	.9912	.3737	-.1570	-.0100	-.0015	-.0071	15.40	1.0154	.3836	-.1600	-.0109	-.0015	-.0025
17.48	1.0845	.4504	-.2171	-.0114	-.0001	-.0089	17.45	1.0657	.4431	-.2174	-.0120	.0004	-.0068
19.50	1.1076	.5003	-.2612	-.0155	-.0032	-.0093	19.56	1.1542	.5241	-.2724	-.0157	.0023	-.0068
21.62	1.1913	.5851	-.3024	-.0184	.0070	-.0142	21.64	1.1971	.6165	-.3030	-.0197	.0070	-.0154
<i>M = 0.96</i>							<i>M = 0.96</i>						
-4.19	-.2424	.0664	.1952	-.0151	-.0004	.0055	-4.19	-.2415	.0649	.1940	-.0173	-.0004	.0031
-1.92	-.0020	.0619	.0951	-.0146	-.0013	.0076	-1.90	-.0009	.0599	.0975	-.0162	-.0011	.0047
0.36	.2475	.0761	-.0183	-.0156	-.0018	.0091	0.36	.2389	.0755	-.0104	-.0166	-.0013	.0043
2.62	.4640	.0986	-.0898	-.0165	-.0021	.0093	2.61	.4760	.1056	-.1212	-.0200	-.0019	.0032
4.87	.6501	.1347	-.1376	-.0104	-.0014	.0053	4.85	.6316	.1323	-.1278	-.0129	-.0016	.0020
7.09	.8212	.1884	-.1944	-.0133	-.0017	.0040	7.10	.8223	.1882	-.1768	-.0148	-.0018	-.0001
9.35	1.0345	.2724	-.2838	-.0122	-.0020	.0012	9.32	1.0182	.2488	-.2795	-.0157	-.0018	-.0040
11.52	1.1675	.3592	-.3407	-.0156	-.0032	.0003	11.46	1.0824	.3296	-.2590	-.0157	-.0017	-.0026

TABLE III.- DATA OBTAINED WITH JET CONTROLS INCLUDING WING-TIP
INLETS AND LARGE PLENUM CHAMBER IN WINGS

Jets closed							Six inboard 0.125-inch-diameter jets open.						
<i>a</i>	<i>C_L</i>	<i>C_D</i>	<i>C_m</i>	<i>C_i</i>	<i>C_n</i>	<i>C_y</i>	<i>a</i>	<i>C_L</i>	<i>C_D</i>	<i>C_m</i>	<i>C_i</i>	<i>C_n</i>	<i>C_y</i>
<i>M = 0.60</i>							<i>M = 0.60</i>						
-4.22	-.3440	.0475	.1565	-.0020	-.0001	.0021	-4.23	-.3555	.0554	.1577	-.0075	-.0014	.0060
-4.10	-.1821	.0371	.1057	-.0019	-.0002	.0034	-4.11	-.1905	.0415	.1079	-.0071	-.0015	.0034
-1.98	-.0134	.0325	.0968	-.0021	-.0003	.0030	-1.99	-.0218	.0360	.0598	-.0070	-.0013	.0072
0.15	.1652	.0353	.0134	-.0020	-.0004	.0034	0.15	.1549	.0390	.0154	-.0073	-.0017	.0034
2.28	.3400	.0464	-.0309	-.0021	-.0007	.0016	2.29	.3425	.0492	-.0280	-.0072	-.0014	.0039
4.42	.5172	.0707	-.0687	-.0022	-.0004	.0047	4.43	.5235	.0746	-.0687	-.0072	-.0011	.0067
6.54	.6703	.1151	-.1019	-.0024	-.0003	.0041	6.54	.6700	.1157	-.1044	-.0057	.0000	.0018
8.64	.7703	.1629	-.1093	-.0020	-.0004	.0043	8.63	.7699	.1654	-.1112	-.0071	.0017	.0059
10.70	.8113	.2132	-.0724	-.0018	-.0005	.0015	10.69	.8046	.2146	-.0796	-.0057	.0010	.0024
12.73	.8318	.2577	-.0558	-.0015	-.0008	.0019	12.73	.8328	.2568	-.0618	-.0040	.0010	.0011
14.75	.8558	.3018	-.0743	-.0020	-.0007	-.0001	14.75	.8496	.3026	-.0802	-.0035	.0010	-.0010
16.79	.8970	.3477	-.1095	-.0034	-.0003	-.0020	16.79	.9003	.3528	-.1127	-.0049	-.0003	-.0024
18.83	.9549	.4077	-.1381	-.0036	-.0002	-.0009	18.83	.9580	.4112	-.1443	-.0061	.0004	-.0055
<i>M = 0.80</i>							<i>M = 0.80</i>						
-6.37	-.4074	.0579	.1832	-.0020	-.0001	.0013	-6.37	-.4062	.0587	.1823	-.0076	-.0008	.0024
-4.17	-.2093	.0386	.1241	-.0018	-.0001	-.0000	-4.17	-.2078	.0413	.1214	-.0070	-.0009	.0023
-1.95	-.0087	.0318	.0680	-.0023	-.0002	.0018	-1.96	-.0145	.0359	.0678	-.0074	-.0012	.0029
0.25	.1916	.0382	.0182	-.0021	-.0003	.0030	0.25	.1925	.0395	.0180	-.0079	-.0013	.0042
2.50	.4153	.0543	-.0347	-.0026	-.0007	.0039	2.49	.4039	.0566	-.0324	-.0079	-.0011	.0041
4.69	.5847	.0865	-.0761	-.0008	-.0003	.0032	4.69	.5877	.0903	-.0788	-.0065	-.0009	.0028
6.84	.7119	.1323	-.0933	-.0002	-.0001	.0024	6.84	.7123	.1362	-.0981	-.0062	-.0009	.0030
8.94	.7673	.1818	-.0779	-.0004	-.0004	.0022	8.94	.7751	.1865	-.0957	-.0063	-.0014	.0040
10.99	.7874	.2247	-.0595	-.0017	-.0005	.0009	10.99	.7982	.2301	-.0673	-.0041	-.0008	-.0000
13.04	.8239	.2711	-.0689	-.0020	-.0002	.0002	13.04	.8322	.2735	-.0800	-.0059	-.0002	-.0011
15.09	.8743	.3227	-.1031	-.0022	-.0004	-.0009	15.09	.8775	.3266	-.1122	-.0052	-.0003	-.0047
17.16	.9311	.3778	-.1312	-.0033	-.0000	-.0010	17.16	.9387	.3824	-.1404	-.0065	.0004	-.0047
19.24	1.0055	.4454	-.1736	-.0042	.0007	-.0041	19.23	1.0038	.4462	-.1797	-.0081	.0018	-.0061
<i>M = 0.85</i>							<i>M = 0.85</i>						
-6.41	-.4327	.0606	.2025	-.0024	-.0002	.0021	-6.41	-.4219	.0522	.1972	-.0083	-.0009	.0032
-4.18	-.2185	.0403	.1389	-.0013	.0001	.0015	-4.17	-.2113	.0376	.1352	-.0076	-.0004	.0047
-1.94	-.0064	.0349	.0761	-.0018	-.0001	.0033	-1.94	-.0057	.0319	.0771	-.0075	-.0010	.0058
0.31	.2074	.0384	.0181	-.0019	-.0002	.0032	0.33	.2240	.0349	.0201	-.0081	-.0012	.0086
2.56	.4338	.0611	-.0380	-.0013	-.0003	.0035	2.58	.4487	.0580	-.0390	-.0074	-.0008	.0060
4.79	.6227	.0988	-.0802	-.0025	-.0005	.0002	4.81	.6363	.0967	-.0847	-.0034	-.0002	.0048
6.92	.7247	.1425	-.0924	-.0025	-.0004	.0009	6.93	.7422	.1439	-.1025	-.0055	-.0008	.0048
9.01	.7705	.1888	-.0755	-.0004	-.0002	.0011	9.02	.7842	.1919	-.1019	-.0053	-.0009	.0029
11.08	.8020	.2357	-.0612	-.0015	-.0008	-.0007	11.10	.8268	.2382	-.0689	-.0052	-.0004	.0039
13.15	.8524	.2844	-.0729	-.0021	-.0003	-.0001	13.16	.8687	.2863	-.0853	-.0067	.0000	.0012
15.22	.9172	.3428	-.1153	-.0026	-.0004	-.0022	15.23	.9292	.3434	-.1219	-.0066	.0002	-.0010
17.28	.9731	.4005	-.1559	-.0034	.0002	-.0029	17.29	.9855	.4013	-.1619	-.0068	.0004	-.0009
19.37	1.0423	.4681	-.1947	-.0043	.0017	-.0097	19.37	1.0506	.4678	-.2043	-.0079	.0025	-.0040
<i>M = 0.90</i>							<i>M = 0.90</i>						
-6.45	-.4727	.0719	.2491	-.0027	-.0005	.0008	-6.45	-.4753	.0727	.2526	-.0091	-.0005	.0052
-4.20	-.2494	.0473	.1688	-.0013	-.0004	-.0003	-4.19	-.2390	.0479	.1708	-.0082	-.0002	.0061
-1.94	-.0108	.0397	.0869	-.0016	-.0007	.0014	-1.92	-.0044	.0406	.0860	-.0083	-.0012	.0073
0.36	.2504	.0479	.0024	-.0016	-.0008	.0017	0.39	.2704	.0512	-.0014	-.0084	-.0013	.0084
2.61	.4638	.0763	-.0628	-.0001	-.0005	.0003	2.62	.4710	.0788	-.0639	-.0068	-.0009	.0073
4.83	.6258	.1136	-.0950	.0032	-.0001	.0003	4.84	.6376	.1162	-.0977	-.0030	-.0004	.0048
6.99	.7481	.1566	-.1060	.0024	-.0004	.0002	7.05	.7900	.1640	-.1205	-.0019	-.0002	.0047
9.12	.8120	.2044	-.0895	.0036	-.0001	-.0029	9.13	.8261	.2068	-.0962	-.0036	-.0003	.0024
11.19	.8416	.2506	-.0767	-.0012	-.0008	-.0008	11.25	.8932	.2659	-.0965	-.0054	-.0004	.0032
13.30	.9118	.3087	-.0849	-.0018	-.0003	-.0022	13.32	.9324	.3155	-.0938	-.0057	.0000	.0018
15.39	.9905	.3760	-.1259	-.0022	-.0003	-.0055	15.46	1.0089	.3822	-.0846	-.0057	.0003	.0063
17.47	1.0680	.4366	-.1750	-.0031	-.0003	-.0050	17.50	1.0893	.4502	-.1893	-.0057	.0000	-.0016
19.48	1.0723	.4901	-.2242	-.0045	.0004	-.0097	19.56	1.1419	.5166	-.2387	-.0078	.0018	-.0046
<i>M = 0.96</i>							<i>M = 0.96</i>						
-4.18	-.2261	.0679	.1790	-.0012	-.0002	-.0021	-4.16	-.2128	.0639	.1764	-.0065	.0004	.0032
-1.91	-.0040	.0409	.0868	-.0012	-.0005	-.0001	-1.90	-.0081	.0563	.0889	-.0067	.0000	.0047
0.35	.2421	.0722	-.0183	-.0019	-.0013	.0000	0.35	.2354	.0692	-.0088	-.0065	-.0008	.0068
2.61	.4744	.1021	-.1232	-.0021	-.0010	.0001	2.64	.4908	.1016	-.1219	-.0070	-.0007	.0061
4.83	.6487	.1389	-.1797	-.0038	-.0012	-.0010	4.88	.6900	.1431	-.1916	-.0089	-.0010	.0046
7.07	.8197	.1927	-.2155	-.0038	-.0011	-.0005	7.11	.8510	.1973	-.2121	-.0091	-.0010	.0059
							9.34	1.0499	.2802	-.3094	-.0077	-.0010	.0022

TABLE III.- DATA OBTAINED WITH JET CONTROLS INCLUDING WING-TIP
INLETS AND LARGE PLENUM CHAMBER IN WINGS - Continued

Twelve inboard 0.125-inch-diameter jets open.							Eighteen inboard 0.125-inch-diameter jets open.						
<i>a</i>	<i>C_L</i>	<i>C_D</i>	<i>C_m</i>	<i>C_i</i>	<i>C_n</i>	<i>C_y</i>	<i>a</i>	<i>C_L</i>	<i>C_D</i>	<i>C_m</i>	<i>C_i</i>	<i>C_n</i>	<i>C_y</i>
<i>M</i> = 0.60							<i>M</i> = 0.60						
-6.23	-.3574	.0566	.1582	-.0123	-.0018	.0039	-6.23	-.3593	.0550	.1629	-.0174	-.0019	.0065
-4.11	-.1921	.0438	.1091	-.0120	-.0019	.0035	-4.10	-.1868	.0421	.1129	-.0172	-.0022	.0060
-1.98	-.0161	.0390	.0600	-.0121	-.0019	.0072	-1.97	-.0072	.0363	.0638	-.0173	-.0024	.0077
0.15	.1957	.0412	.0175	-.0121	-.0020	.0056	0.16	.1684	.0388	.0185	-.0172	-.0025	.0078
2.28	.3344	.0504	-.0261	-.0122	-.0019	.0060	2.31	.3543	.0495	-.0250	-.0172	-.0024	.0082
4.42	.5192	.0762	-.0696	-.0123	-.0018	.0064	4.44	.5396	.0762	-.0721	-.0169	-.0024	.0102
6.55	.6807	.1197	-.1079	-.0093	-.0007	.0034	6.55	.6906	.1190	-.1086	-.0135	-.0013	.0074
8.64	.7734	.1688	-.1128	-.0106	-.0022	.0056	8.65	.7871	.1687	-.1162	-.0143	-.0025	.0093
10.68	.8018	.2156	-.0848	-.0086	-.0013	.0057	10.71	.8361	.2230	-.0936	-.0115	-.0009	.0071
12.72	.8531	.2619	-.0696	-.0062	-.0014	.0021	12.74	.8576	.2665	-.0810	-.0080	-.0010	.0030
14.74	.8539	.3053	-.0900	-.0060	-.0012	-.0002	14.75	.8781	.3108	-.1032	-.0080	-.0002	.0005
16.78	.9006	.3537	-.1217	-.0080	-.0005	-.0015	16.79	.9212	.3598	-.1303	-.0102	-.0007	-.0002
18.84	.9717	.4184	-.1496	-.0091	.0008	-.0040	18.83	.9723	.4149	-.1555	-.0114	.0014	-.0027
<i>M</i> = 0.80							<i>M</i> = 0.80						
-6.38	-.4132	.0413	.1832	-.0128	-.0014	.0051	-6.37	-.4055	.0587	.1873	-.0182	-.0017	.0056
-4.18	-.2120	.0435	.1227	-.0125	-.0016	.0050	-4.15	-.2017	.0409	.1250	-.0177	-.0019	.0067
-1.95	-.0062	.0374	.0697	-.0124	-.0018	.0072	-1.95	-.0031	.0356	.0720	-.0176	-.0022	.0088
0.27	.1989	.0422	.0197	-.0130	-.0022	.0070	0.29	.2091	.0402	.0220	-.0184	-.0024	.0101
2.51	.4205	.0599	-.0345	-.0129	-.0021	.0066	2.52	.4283	.0590	-.0341	-.0183	-.0023	.0094
4.70	.6024	.0934	-.0830	-.0119	-.0019	.0064	4.73	.6223	.0939	-.0857	-.0175	-.0026	.0089
6.85	.7227	.1407	-.1014	-.0099	-.0019	.0053	6.85	.7333	.1406	-.1047	-.0152	-.0028	.0104
8.94	.7763	.1887	-.0901	-.0094	-.0019	.0047	8.95	.7870	.1903	-.0970	-.0135	-.0020	.0067
11.00	.8047	.2323	-.0749	-.0076	-.0015	.0031	11.01	.8223	.2355	-.0854	-.0111	-.0012	.0033
13.04	.8360	.2785	-.0889	-.0082	-.0008	-.0009	13.05	.8694	.2797	-.0999	-.0124	-.0001	.0004
15.10	.8860	.3302	-.1218	-.0088	-.0002	-.0017	15.10	.8992	.3317	-.1361	-.0127	.0005	-.0020
17.14	.9425	.3853	-.1482	-.0100	.0005	-.0029	17.18	.9669	.3917	-.1641	-.0133	.0017	-.0032
19.25	1.0219	.4551	-.1918	-.0103	.0005	-.0049	19.26	1.0324	.4571	-.2046	-.0135	.0019	-.0049
<i>M</i> = 0.85							<i>M</i> = 0.85						
-6.43	-.4359	.0651	.1987	-.0129	-.0015	.0039	-6.40	-.4300	.0619	.2134	-.0189	-.0014	.0079
-4.18	-.2192	.0443	.1347	-.0123	-.0014	.0032	-4.15	-.2138	.0418	.1659	-.0177	-.0013	.0111
-1.94	-.0068	.0377	.0764	-.0127	-.0020	.0036	-1.93	.0028	.0359	.0768	-.0179	-.0021	.0083
0.33	.2231	.0446	.0182	-.0130	-.0022	.0057	0.33	.2281	.0427	.0203	-.0185	-.0024	.0098
2.58	.4544	.0668	-.0429	-.0131	-.0019	.0054	2.60	.4755	.0678	-.0494	-.0181	-.0025	.0035
4.80	.6373	.1051	-.0888	-.0094	-.0014	.0041	4.82	.6537	.1054	-.0915	-.0159	-.0024	.0088
6.93	.7401	.1589	-.1042	-.0077	-.0016	.0032	6.95	.7502	.1497	-.1067	-.0125	-.0020	.0067
9.02	.7993	.1971	-.0991	-.0066	-.0009	.0006	9.04	.8097	.1971	-.1020	-.0083	-.0010	.0031
11.10	.8312	.2455	-.0781	-.0079	-.0012	.0002	11.11	.8459	.2466	-.0864	-.0124	-.0009	.0032
13.14	.8707	.2935	-.0976	-.0097	-.0006	-.0030	13.14	.8755	.2908	-.1094	-.0127	-.0001	-.0004
15.22	.9286	.3498	-.1353	-.0094	.0004	-.0057	15.21	.9353	.3478	-.1475	-.0133	.0014	-.0033
17.32	1.0121	.4165	-.1761	-.0105	.0010	-.0061	17.30	1.0123	.4144	-.1899	-.0136	.0017	-.0040
19.36	1.0449	.4701	-.2049	-.0089	.0004	-.0094	19.37	1.0653	.4769	-.2227	-.0117	.0021	-.0125
<i>M</i> = 0.90							<i>M</i> = 0.90						
-6.46	-.4762	.0754	.2440	-.0141	-.0012	.0051	-6.47	-.4893	.0752	.2540	-.0198	-.0007	.0026
-4.21	-.2530	.0513	.1730	-.0125	-.0011	.0037	-4.21	-.2548	.0507	.1750	-.0175	-.0006	.0029
-1.91	.0076	.0427	.0838	-.0125	-.0018	.0046	-1.92	.0014	.0421	.0845	-.0185	-.0018	.0047
0.39	.2671	.0527	.0004	-.0133	-.0021	.0086	0.39	.2719	.0510	-.0030	-.0186	-.0023	.0070
2.64	.4853	.0811	-.0703	-.0118	-.0020	.0077	2.65	.4964	.0792	-.0766	-.0175	-.0023	.0070
4.85	.6478	.1187	-.1012	-.0072	-.0015	.0055	4.86	.6575	.1180	-.1086	-.0112	-.0016	.0047
7.02	.7727	.1647	-.1188	-.0074	-.0019	.0058	7.02	.7706	.1609	-.1228	-.0135	-.0023	.0041
9.11	.8112	.2073	-.0969	-.0074	-.0011	.0021	9.11	.8204	.2072	-.1091	-.0117	-.0007	-.0020
11.19	.8626	.2582	-.0917	-.0085	-.0011	.0023	11.22	.8975	.2633	-.1316	-.0116	-.0002	.0061
13.31	.9328	.3179	-.1081	-.0090	-.0005	-.0013	13.33	.9531	.3214	-.1222	-.0116	-.0001	-.0051
15.40	1.0119	.3838	-.1491	-.0091	.0002	-.0032	15.43	1.0321	.3898	-.1637	-.0107	-.0001	-.0007
17.50	1.0886	.4536	-.1983	-.0093	.0006	-.0090	17.44	1.0637	.4412	-.2148	-.0106	.0014	-.0097
19.54	1.1519	.5161	-.2619	-.0094	.0020	-.0075	19.56	1.1516	.5208	-.2534	-.0133	.0018	-.0088
<i>M</i> = 0.96							<i>M</i> = 0.96						
-4.18	-.2281	.0680	.1834	-.0111	.0001	.0028	-4.18	-.2285	.0649	.1850	-.0172	.0004	-.0004
-1.91	.0031	.0425	.0882	-.0112	-.0004	.0046	-1.90	.0112	.0606	.0874	-.0166	-.0003	.0024
0.37	.2543	.0754	-.0198	-.0111	-.0013	.0055	0.37	.2526	.0707	-.0206	-.0163	-.0010	.0054
2.63	.4933	.1034	-.1277	-.0111	-.0007	.0042	2.63	.4904	.1029	-.1266	-.0192	-.0007	.0009
4.85	.6673	.1408	-.1824	-.0160	-.0014	.0021	4.87	.6950	.1446	-.1969	-.0272	-.0011	.0005
7.10	.8601	.2029	-.2391	-.0119	-.0013	.0032	7.11	.8681	.1993	-.2081	-.0165	-.0013	.0008
9.47	1.0327	.2793	-.1530	-.0083	-.0010	.0168							

TABLE III.- DATA OBTAINED WITH JET CONTROLS INCLUDING WING-TIP
INLETS AND LARGE PLENUM CHAMBER IN WINGS - Continued

Twenty-four 0.125-inch-diameter jets open							Twenty-four 0.140-inch-diameter jets open.						
<i>a</i>	<i>C_L</i>	<i>C_D</i>	<i>C_m</i>	<i>C_l</i>	<i>C_n</i>	<i>C_y</i>	<i>a</i>	<i>C_L</i>	<i>C_D</i>	<i>C_m</i>	<i>C_l</i>	<i>C_n</i>	<i>C_y</i>
<i>M = 0.60</i>							<i>M = 0.60</i>						
-6.23	-.3613	.0557	.1615	-.0224	-.0021	.0062	-6.23	-.3520	.0552	.1613	-.0254	-.0026	.0062
-4.10	-.1845	.0429	.1105	-.0222	-.0027	.0096	-4.10	-.1896	.0438	.1120	-.0255	-.0027	.0077
-1.98	-.0085	.0385	.0613	-.0225	-.0026	.0093	-1.98	-.0093	.0385	.0609	-.0256	-.0031	.0091
0.16	.1711	.0410	.0149	-.0226	-.0026	.0133	0.16	.1704	.0420	.0154	-.0257	-.0035	.0113
2.30	.3537	.0516	-.0286	-.0223	-.0026	.0138	2.31	.3534	.0521	-.0273	-.0255	-.0036	.0138
4.44	.5430	.0786	-.0758	-.0215	-.0031	.0137	4.44	.5468	.0788	-.0763	-.0241	-.0037	.0137
6.56	.7050	.1223	-.1132	-.0178	-.0021	.0109	6.56	.7056	.1240	-.1146	-.0200	-.0029	.0126
8.64	.7876	.1703	-.1215	-.0178	-.0028	.0127	8.64	.7918	.1720	-.1239	-.0200	-.0032	.0124
10.69	.8193	.2202	-.0998	-.0150	-.0012	.0081	10.69	.8273	.2224	-.1048	-.0161	-.0009	.0056
12.73	.8514	.2668	-.0899	-.0108	-.0009	.0038	12.73	.8563	.2683	-.0949	-.0119	-.0002	.0013
14.75	.8791	.3112	-.1121	-.0106	.0001	-.0005	14.74	.8704	.3083	-.1179	-.0112	.0005	-.0013
16.79	.9253	.3624	-.1384	-.0122	-.0009	-.0029	16.78	.9236	.3607	-.1414	-.0130	.0014	-.0055
18.83	.9762	.4182	-.1645	-.0140	.0018	-.0037	18.84	.9850	.4209	-.1693	-.0135	.0020	-.0062
<i>M = 0.80</i>							<i>M = 0.80</i>						
-6.37	-.4150	.0420	.1900	-.0236	-.0018	.0058	-6.37	-.4070	.0411	.1870	-.0260	-.0019	.0082
-4.17	-.2060	.0431	.1245	-.0229	-.0018	.0064	-4.17	-.2148	.0449	.1308	-.0262	-.0024	.0086
-1.94	.0002	.0370	.0684	-.0229	-.0023	.0085	-1.94	-.0030	.0378	.0710	-.0260	-.0029	.0114
0.26	.2081	.0431	.0181	-.0237	-.0025	.0110	0.29	.2129	.0432	.0190	-.0263	-.0033	.0124
2.51	.4255	.0395	-.0381	-.0234	-.0027	.0115	2.53	.4384	.0421	-.0417	-.0258	-.0041	.0138
4.72	.6177	.0956	-.0909	-.0218	-.0031	.0122	4.73	.6237	.0958	-.0896	-.0249	-.0041	.0150
6.86	.7385	.1428	-.1093	-.0196	-.0033	.0125	6.87	.7481	.1442	-.1146	-.0193	-.0031	.0106
8.94	.7801	.1899	-.1030	-.0188	-.0023	.0072	8.93	.7870	.1910	-.1046	-.0202	-.0028	.0081
11.00	.8233	.2375	-.0948	-.0146	-.0013	.0035	11.00	.8260	.2371	-.0996	-.0192	-.0013	.0029
13.04	.8529	.2820	-.1087	-.0155	-.0007	.0009	13.05	.8650	.2852	-.1141	-.0158	-.0008	.0017
15.12	.9164	.3380	-.1398	-.0151	.0005	-.0022	15.10	.9101	.3363	-.1485	-.0157	.0009	-.0021
17.17	.9640	.3911	-.1679	-.0154	.0010	-.0038	17.17	.9786	.3970	-.1829	-.0157	.0009	-.0042
19.24	1.0358	.4603	-.2117	-.0162	.0014	-.0045	19.25	1.0402	.4800	-.2185	-.0154	.0012	-.0039
<i>M = 0.85</i>							<i>M = 0.85</i>						
-6.42	-.4404	.0456	.2042	-.0242	-.0015	.0058	-6.41	-.4306	.0440	.2060	-.0265	-.0019	.0086
-4.19	-.2252	.0456	.1390	-.0234	-.0017	.0062	-4.18	-.2194	.0454	.1401	-.0258	-.0023	.0089
-1.93	.0013	.0394	.0749	-.0234	-.0024	.0080	-1.93	.0051	.0385	.0776	-.0255	-.0027	.0122
0.33	.2315	.0450	.0145	-.0251	-.0028	.0106	0.34	.2337	.0454	.0186	-.0261	-.0035	.0145
2.58	.4338	.0688	-.0533	-.0239	-.0030	.0104	2.60	.4779	.0704	-.0568	-.0246	-.0035	.0143
4.81	.6335	.1073	-.0980	-.0217	-.0032	.0116	4.82	.6454	.1080	-.1002	-.0248	-.0043	.0145
6.92	.7408	.1511	-.1118	-.0178	-.0023	.0072	6.96	.7672	.1942	-.1182	-.0171	-.0023	.0082
9.03	.8140	.2012	-.1099	-.0134	-.0018	.0046	9.01	.7882	.2003	-.1053	-.0200	-.0023	.0075
11.09	.8444	.2486	-.0975	-.0157	-.0016	.0029	11.09	.8441	.2465	-.1012	-.0158	-.0013	.0025
13.14	.8754	.2944	-.1163	-.0166	-.0006	.0011	13.15	.8842	.2939	-.1193	-.0163	-.0004	.0008
15.22	.9403	.3511	-.1540	-.0163	.0001	-.0029	15.22	.9527	.3548	-.1681	-.0170	.0009	-.0026
17.28	1.0028	.4122	-.1917	-.0156	.0005	-.0058	17.29	1.0169	.4165	-.2094	-.0147	-.0004	-.0017
19.37	1.0624	.4755	-.2235	-.0146	.0006	-.0103	19.37	1.0778	.4821	-.2355	-.0141	.0001	-.0068
<i>M = 0.90</i>							<i>M = 0.90</i>						
-6.47	-.4807	.0774	.2511	-.0249	-.0012	.0034	-6.46	-.4821	.0774	.2546	-.0269	-.0006	.0077
-4.21	-.2547	.0524	.1718	-.0234	-.0012	.0048	-4.20	-.2469	.0516	.1717	-.0282	-.0010	.0073
-1.91	.0088	.0441	.0812	-.0234	-.0022	.0079	-1.89	.0208	.0430	.0887	-.0254	-.0024	.0119
0.39	.2780	.0552	-.0110	-.0238	-.0033	.0106	0.42	.2991	.0544	-.0113	-.0260	-.0038	.0147
2.65	.4981	.0832	-.0805	-.0235	-.0033	.0100	2.65	.5047	.0837	-.0888	-.0245	-.0042	.0178
4.85	.6597	.1213	-.1190	-.0164	-.0022	.0074	4.86	.6677	.1203	-.1149	-.0221	-.0035	.0145
7.02	.7770	.1656	-.1267	-.0215	-.0034	.0095	7.04	.7932	.1672	-.1323	-.0209	-.0037	.0137
9.11	.8319	.2140	-.1147	-.0146	-.0011	.0001	9.13	.8443	.2140	-.1201	-.0133	-.0010	.0043
11.22	.8944	.2658	-.1148	-.0149	-.0015	.0009	11.22	.8952	.2657	-.1206	-.0166	-.0011	.0026
13.32	.9546	.3244	-.1340	-.0151	-.0008	-.0032	13.31	.9565	.3214	-.1349	-.0156	-.0005	.0013
15.42	1.0441	.3948	-.1776	-.0158	-.0002	-.0045	15.41	1.0358	.3881	-.1834	-.0151	.0007	-.0046
17.47	1.0924	.4533	-.2210	-.0114	-.0012	-.0093	17.44	1.0749	.4433	-.2295	-.0121	-.0006	-.0046
19.53	1.1334	.5139	-.2628	-.0170	.0030	-.0112	19.51	1.1288	.5077	-.2663	-.0132	-.0004	-.0073
<i>M = 0.96</i>							<i>M = 0.96</i>						
-4.17	-.2221	.0690	.1849	-.0219	-.0002	.0029	-4.16	-.2174	.0695	.1872	-.0245	-.0001	.0065
-1.91	.0002	.0625	.0879	-.0215	-.0010	.0047	-1.89	.0172	.0597	.0892	-.0238	-.0009	.0105
0.39	.2781	.0796	-.0264	-.0214	-.0017	.0093	0.39	.2674	.0724	-.0245	-.0240	-.0019	.0117
2.63	.4909	.1073	-.1274	-.0233	-.0018	.0073	2.65	.5003	.1049	-.1230	-.0249	-.0025	.0124
4.88	.6851	.1456	-.1847	-.0273	-.0019	.0064	4.90	.7050	.1444	-.1833	-.0299	-.0019	.0110
7.09	.8604	.2029	-.2494	-.0201	-.0017	.0025	7.13	.8804	.2044	-.2355	-.0211	-.0015	.0083

TABLE III.- DATA OBTAINED WITH JET CONTROLS INCLUDING WING-TIP
INLETS AND LARGE PLENUM CHAMBER IN WINGS - Continued

Twenty-four 0.156-inch-diameter jets open.							Twenty-four 0.172-inch-diameter jets open.						
α	C_L	C_D	C_m	C_i	C_n	C_y	α	C_L	C_D	C_m	C_i	C_n	C_y
M = 0.60							M = 0.60						
-6.21	-.3382	.0489	.1534	-.0272	-.0027	.0094	-6.22	-.3455	.0554	.1580	-.0287	-.0030	.0078
-4.09	-.1754	.0421	.1080	-.0277	-.0030	.0113	-4.10	-.1792	.0441	.1088	-.0284	-.0033	.0114
-1.97	.0010	.0352	.0597	-.0276	-.0034	.0131	-1.97	-.0028	.0398	.0605	-.0286	-.0034	.0131
0.17	.1842	.0386	.0150	-.0283	-.0036	.0174	0.17	.1875	.0420	.0140	-.0287	-.0037	.0133
2.31	.3674	.0503	-.0295	-.0275	-.0035	.0177	2.30	.3597	.0528	-.0296	-.0286	-.0035	.0156
4.45	.5604	.0798	-.0768	-.0271	-.0039	.0198	4.44	.5491	.0804	-.0760	-.0280	-.0042	.0154
6.57	.7120	.1252	-.1163	-.0246	-.0042	.0205	6.56	.7047	.1238	-.1161	-.0237	-.0034	.0144
8.65	.8060	.1697	-.1243	-.0222	-.0033	.0165	8.65	.8046	.1751	-.1245	-.0237	-.0037	.0124
10.70	.8448	.2251	-.1088	-.0180	-.0008	.0115	10.69	.8303	.2234	-.1098	-.0187	-.0012	.0069
12.73	.8738	.2708	-.1014	-.0134	-.0003	.0067	12.72	.8595	.2684	-.1073	-.0141	-.0002	.0018
14.77	.9047	.3181	-.1245	-.0126	.0009	.0020	14.76	.8904	.3154	-.1322	-.0135	.0010	-.0029
16.81	.9574	.3709	-.1909	-.0146	.0024	-.0022	16.80	.9400	.3672	-.1547	-.0150	.0023	-.0049
18.85	1.0089	.4270	-.1742	-.0151	.0032	-.0024	18.83	.9912	.4230	-.1789	-.0155	.0033	-.0072
M = 0.80							M = 0.80						
-6.35	-.3923	.0592	.1802	-.0281	-.0020	.0089	-6.34	-.3998	.0609	.1800	-.0290	-.0021	.0047
-4.14	-.1932	.0411	.1274	-.0279	-.0022	.0105	-4.15	-.2006	.0441	.1237	-.0288	-.0027	.0064
-1.93	.0111	.0376	.0675	-.0279	-.0027	.0138	-1.93	.0058	.0389	.0680	-.0288	-.0030	.0083
0.30	.2246	.0413	.0148	-.0285	-.0033	.0148	0.30	.2236	.0439	.0172	-.0295	-.0036	.0109
2.53	.4424	.0411	-.0420	-.0278	-.0041	.0179	2.52	.4371	.0626	-.0421	-.0284	-.0045	.0123
4.74	.6413	.0987	-.0938	-.0273	-.0041	.0188	4.74	.6409	.0990	-.0952	-.0286	-.0048	.0131
6.88	.7579	.1460	-.1168	-.0227	-.0030	.0145	6.88	.7575	.1471	-.1195	-.0234	-.0038	.0073
8.95	.8044	.1949	-.1112	-.0226	-.0028	.0132	8.93	.7872	.1927	-.1120	-.0236	-.0033	.0060
11.01	.8404	.2418	-.1074	-.0180	-.0010	.0049	11.00	.8308	.2398	-.1092	-.0179	-.0013	-.0037
13.05	.8750	.2882	-.1216	-.0171	-.0001	.0009	13.03	.8653	.2888	-.1311	-.0181	-.0002	-.0073
15.11	.9222	.3396	-.1560	-.0176	.0011	-.0013	15.10	.9194	.3388	-.1892	-.0181	.0015	-.0100
17.18	.9907	.4013	-.1903	-.0168	.0015	-.0023	17.17	.9793	.3972	-.1984	-.0167	.0015	-.0082
19.25	1.0414	.4606	-.2270	-.0157	.0006	-.0024	19.25	1.0452	.4620	-.2308	-.0165	.0014	-.0109
M = 0.85							M = 0.85						
-6.40	-.4194	.0644	.1948	-.0285	-.0018	.0105	-6.41	-.4266	.0633	.1997	-.0293	-.0020	.0041
-4.15	-.2042	.0445	.1356	-.0281	-.0022	.0098	-4.19	-.2249	.0462	.1384	-.0289	-.0023	.0061
-1.93	.0114	.0385	.0743	-.0283	-.0027	.0144	-1.94	.0044	.0388	.0742	-.0289	-.0030	.0092
0.39	.2489	.0465	.0130	-.0283	-.0032	.0154	0.33	.2371	.0441	.0137	-.0292	-.0037	.0105
2.62	.4862	.0715	-.0571	-.0288	-.0046	.0176	2.62	.4901	.0727	-.0603	-.0303	-.0047	.0147
4.80	.6532	.1052	-.1008	-.0283	-.0046	.0163	4.83	.6707	.1102	-.1037	-.0287	-.0032	.0122
6.96	.7731	.1555	-.1229	-.0206	-.0028	.0112	6.94	.7641	.1540	-.1225	-.0216	-.0044	.0059
9.01	.8036	.2002	-.1115	-.0225	-.0029	.0081	9.00	.7945	.1984	-.1117	-.0235	-.0029	.0054
11.09	.8498	.2490	-.1109	-.0186	-.0009	.0014	11.08	.8409	.2449	-.1136	-.0188	-.0007	-.0044
13.17	.9031	.3013	-.1312	-.0176	-.0001	-.0005	13.14	.8875	.2974	-.1401	-.0187	-.0004	-.0081
15.22	.9564	.3558	-.1692	-.0188	.0016	-.0045	15.22	.9555	.3564	-.1751	-.0195	.0028	-.0115
17.28	1.0174	.4158	-.2182	-.0153	-.0006	-.0029	17.25	1.0013	.4122	-.2241	-.0161	.0004	-.0100
19.40	1.0965	.4892	-.2444	-.0156	.0000	-.0090	19.35	1.0694	.4788	-.2503	-.0156	.0003	-.0113
M = 0.90							M = 0.90						
-6.45	-.4426	.0752	.2398	-.0287	-.0012	.0056	-6.46	-.4761	.0775	.2506	-.0294	-.0012	.0021
-4.20	-.2431	.0502	.1657	-.0279	-.0016	.0065	-4.21	-.2473	.0532	.1657	-.0282	-.0020	.0028
-1.90	.0201	.0430	.0789	-.0282	-.0023	.0101	-1.90	.0201	.0446	.0788	-.0286	-.0031	.0076
0.40	.2872	.0559	-.0073	-.0282	-.0039	.0136	0.40	.2826	.0542	-.0046	-.0289	-.0040	.0091
2.66	.5121	.0847	-.0870	-.0294	-.0046	.0151	2.66	.5095	.0845	-.0860	-.0303	-.0049	.0116
4.87	.6770	.1217	-.1221	-.0261	-.0039	.0124	4.87	.6786	.1218	-.1223	-.0276	-.0048	.0088
7.03	.7922	.1669	-.1399	-.0242	-.0039	.0091	7.02	.7877	.1662	-.1393	-.0247	-.0043	.0056
9.07	.8033	.2070	-.1163	-.0239	-.0022	.0043	9.10	.8323	.2130	-.1263	-.0180	-.0015	-.0014
11.23	.9036	.2712	-.1321	-.0198	-.0001	-.0022	11.19	.8826	.2630	-.1294	-.0207	.0002	-.0068
13.24	.9141	.3137	-.1499	-.0180	.0002	-.0055	13.27	.9443	.3203	-.1566	-.0193	.0011	-.0107
15.34	.9941	.3732	-.1838	-.0183	.0021	-.0111	15.36	1.0131	.3822	-.1930	-.0195	.0031	-.0146
17.45	1.0816	.4491	-.2410	-.0158	.0023	-.0139	17.45	1.0905	.4527	-.2495	-.0179	.0033	-.0195
19.57	1.1753	.5324	-.2929	-.0132	.0009	-.0150	19.50	1.1357	.5154	-.2875	-.0159	.0016	-.0195
M = 0.96							M = 0.96						
-4.17	-.2237	.0644	.1817	-.0271	-.0001	.0037	-4.17	-.2239	.0676	.1843	-.0288	.0001	-.0018
-1.90	.0186	.0587	.0835	-.0271	-.0013	.0108	-1.90	.0080	.0605	.0886	-.0275	-.0014	.0035
0.38	.2646	.0707	-.0250	-.0275	-.0024	.0115	0.37	.2626	.0738	-.0276	-.0273	-.0027	.0035
2.64	.4884	.0995	-.1162	-.0331	-.0035	.0142	2.63	.4889	.1038	-.1239	-.0305	-.0029	.0065
4.88	.6941	.1432	-.1910	-.0335	-.0022	.0089	4.90	.7131	.1498	-.2087	-.0335	-.0024	.0019
7.08	.8306	.1882	-.1994	-.0213	-.0015	.0032	7.08	.8397	.1940	-.2236	-.0242	-.0017	-.0019

TABLE III.- DATA OBTAINED WITH JET CONTROLS INCLUDING WING-TIP
INLETS AND LARGE PLENUM CHAMBER IN WINGS - Concluded

Eighteen outboard 0.172-inch-diameter jets open.							Twelve outboard 0.172-inch-diameter jets open.						
α	C_L	C_D	C_m	C_l	C_n	C_y	α	C_L	C_D	C_m	C_l	C_n	C_y
<i>M = 0.60</i>							<i>M = 0.60</i>						
-6.23	-.3521	.0553	.1581	-.0238	-.0015	.0059	-6.23	-.3526	.0549	.1583	-.0178	-.0012	.0040
-4.10	-.1825	.0424	.1097	-.0239	-.0020	.0056	-4.10	-.1798	.0417	.1074	-.0175	-.0012	.0054
-1.98	-.0093	.0381	.0597	-.0244	-.0020	.0071	-1.97	-.0039	.0362	.0601	-.0178	-.0015	.0073
0.16	.1780	.0405	.0147	-.0245	-.0022	.0072	0.16	.1755	.0400	.0137	-.0183	-.0017	.0114
2.30	.3649	.0515	-.0300	-.0244	-.0025	.0118	2.30	.3580	.0496	-.0298	-.0181	-.0018	.0098
4.44	.5481	.0785	-.0771	-.0229	-.0033	.0137	4.45	.5508	.0777	-.0781	-.0175	-.0024	.0140
6.55	.7069	.1247	-.1186	-.0206	-.0034	.0121	6.57	.7087	.1239	-.1146	-.0154	-.0027	.0126
8.65	.8077	.1747	-.1257	-.0180	-.0029	.0104	8.66	.8123	.1743	-.1224	-.0135	-.0026	.0128
10.70	.8433	.2234	-.1048	-.0152	-.0003	.0058	10.72	.8517	.2178	-.0964	-.0119	.0004	.0030
12.73	.8650	.2674	-.0949	-.0114	-.0001	-.0006	12.74	.8715	.2487	-.0822	-.0093	.0003	.0011
14.76	.8965	.3143	-.1218	-.0108	.0006	-.0035	14.77	.8892	.3127	-.1043	-.0089	-.0002	.0025
16.80	.9428	.3670	-.1498	-.0117	.0017	-.0064	16.81	.9527	.3715	-.1367	-.0089	.0005	-.0007
18.83	.9948	.4226	-.1739	-.0117	.0019	-.0067	18.85	.9942	.4235	-.1608	-.0091	.0003	-.0033
<i>M = 0.80</i>							<i>M = 0.80</i>						
-6.36	-.3992	.0621	.1541	-.0244	-.0010	.0040	-6.34	-.3844	.0567	.1806	-.0182	-.0004	.0025
-4.15	-.1995	.0419	.1247	-.0231	-.0014	.0067	-4.14	-.1902	.0405	.1233	-.0174	-.0006	.0041
-1.93	.0071	.0364	.0702	-.0234	-.0016	.0088	-1.93	.0112	.0356	.0677	-.0176	-.0012	.0072
0.28	.2132	.0414	.0180	-.0242	-.0021	.0111	0.30	.2214	.0415	.0158	-.0180	-.0015	.0082
2.53	.4388	.0610	-.0414	-.0237	-.0032	.0126	2.53	.4387	.0611	-.0403	-.0179	-.0022	.0114
4.74	.6385	.0964	-.0945	-.0234	-.0038	.0146	4.74	.6303	.0950	-.0901	-.0175	-.0029	.0111
6.88	.7552	.1440	-.1156	-.0184	-.0026	.0106	6.89	.7556	.1441	-.1088	-.0134	-.0015	.0075
8.95	.7990	.1913	-.1062	-.0179	-.0013	.0058	8.94	.7991	.1917	-.0982	-.0135	-.0012	.0058
11.01	.8374	.2395	-.1025	-.0140	-.0001	.0015	11.01	.8231	.2365	-.0873	-.0109	-.0008	.0045
13.05	.8746	.2859	-.1182	-.0146	-.0002	-.0014	13.06	.8623	.2829	-.0988	-.0116	-.0010	.0038
15.17	.9218	.3377	-.1527	-.0153	.0011	-.0038	15.11	.9078	.3343	-.1329	-.0113	-.0008	.0024
17.16	.9671	.3915	-.1902	-.0156	.0022	-.0065	17.17	.9665	.3917	-.1704	-.0125	.0003	-.0015
19.23	1.0335	.4554	-.2308	-.0153	.0028	-.0081	19.22	1.0102	.4471	-.2078	-.0126	-.0001	-.0018
<i>M = 0.85</i>							<i>M = 0.85</i>						
-6.40	-.4192	.0614	.1977	-.0244	-.0007	.0040	-6.40	-.4249	.0636	.2007	-.0186	-.0004	.0019
-4.19	-.2219	.0434	.1405	-.0235	-.0008	.0040	-4.17	-.2058	.0432	.1368	-.0179	-.0004	.0025
-1.92	.0123	.0366	.0751	-.0234	-.0015	.0096	-1.92	.0139	.0373	.0728	-.0177	-.0010	.0043
0.36	.2432	.0439	.0149	-.0238	-.0019	.0106	0.35	.2391	.0446	.0174	-.0185	-.0014	.0084
2.62	.4874	.0701	-.0565	-.0247	-.0033	.0128	2.59	.4758	.0687	-.0525	-.0189	-.0028	.0104
4.82	.6665	.1058	-.1029	-.0229	-.0039	.0124	4.83	.6648	.1075	-.0941	-.0172	-.0029	.0111
6.96	.7731	.1521	-.1190	-.0154	-.0016	.0056	6.96	.7683	.1524	-.1122	-.0106	-.0010	.0038
9.03	.8077	.1990	-.1066	-.0168	-.0007	.0014	9.02	.7982	.1995	-.0982	-.0139	-.0011	.0043
11.11	.8667	.2518	-.1093	-.0154	-.0002	-.0007	11.11	.8460	.2477	-.0992	-.0129	-.0011	.0038
13.15	.8892	.2944	-.1240	-.0162	.0005	-.0034	13.18	.8965	.2997	-.1097	-.0131	-.0010	.0020
15.22	.9660	.3600	-.1778	-.0170	.0025	-.0080	15.23	.9462	.3527	-.1475	-.0133	-.0004	.0004
17.25	.9986	.4078	-.2184	-.0155	.0018	-.0054	17.25	.9850	.4047	-.2020	-.0084	-.0041	.0021
19.37	1.0829	.4830	-.2533	-.0152	.0026	-.0062	19.35	1.0531	.4730	-.2282	-.0093	-.0021	-.0052
<i>M = 0.90</i>							<i>M = 0.90</i>						
-6.44	-.4695	.0744	.2490	-.0246	.0002	.0022	-6.44	-.4686	.0754	.2541	-.0198	.0004	.0006
-4.20	-.2424	.0481	.1640	-.0230	.0000	.0040	-4.20	-.2439	.0512	.1669	-.0174	.0000	.0020
-1.89	.0212	.0399	.0815	-.0231	-.0013	.0081	-1.91	.0121	.0425	.0819	-.0178	-.0009	.0058
0.39	.2825	.0528	-.0065	-.0237	-.0026	.0126	0.40	.2783	.0544	-.0030	-.0185	-.0021	.0083
2.66	.5142	.0818	-.0851	-.0238	-.0028	.0120	2.66	.5004	.0827	-.0797	-.0194	-.0028	.0089
4.87	.6792	.1199	-.1231	-.0215	-.0024	.0089	4.87	.6757	.1195	-.1145	-.0152	-.0021	.0064
7.04	.8004	.1649	-.1380	-.0218	-.0032	.0083	7.05	.8013	.1673	-.1315	-.0178	-.0028	.0068
9.10	.8179	.2074	-.1119	-.0200	-.0010	.0028	9.09	.8084	.2097	-.1038	-.0160	-.0012	.0013
11.22	.8955	.2663	-.1235	-.0167	.0007	-.0023	11.20	.8726	.2609	-.1087	-.0125	-.0012	.0014
13.28	.9367	.3137	-.1417	-.0171	.0011	-.0041	13.32	.9538	.3224	-.1305	-.0121	-.0005	.0015
15.36	1.0166	.3805	-.1920	-.0164	.0023	-.0083	15.38	1.0144	.3824	-.1739	-.0100	-.0015	.0005
17.43	1.0863	.4486	-.2600	-.0129	.0005	-.0096	17.40	1.0470	.4396	-.2307	-.0060	-.0054	.0013
19.63	1.1324	.5131	-.3452	-.0152	.0019	.0078	19.48	1.1053	.5026	-.2696	-.0113	-.0006	-.0059
<i>M = 0.96</i>							<i>M = 0.96</i>						
-4.16	-.2194	.0626	.1824	-.0234	.0005	.0037	-4.17	-.2207	.0643	.1796	-.0183	.0008	.0013
-1.89	.0194	.0357	.0842	-.0232	-.0008	.0076	-1.89	.0152	.0619	.0873	-.0171	-.0004	.0057
0.39	.2718	.0494	-.0235	-.0240	-.0022	.0108	0.37	.2521	.0706	-.0158	-.0183	-.0016	.0093
2.64	.4906	.0998	-.1154	-.0275	-.0026	.0122	2.61	.4636	.0998	-.1038	-.0223	-.0025	.0100
4.89	.7063	.1430	-.1930	-.0286	-.0015	.0056	4.89	.6946	.1449	-.1894	-.0221	-.0009	.0057
7.10	.8529	.1899	-.2198	-.0186	-.0009	.0027	7.11	.8597	.1953	-.2205	-.0134	-.0007	.0005

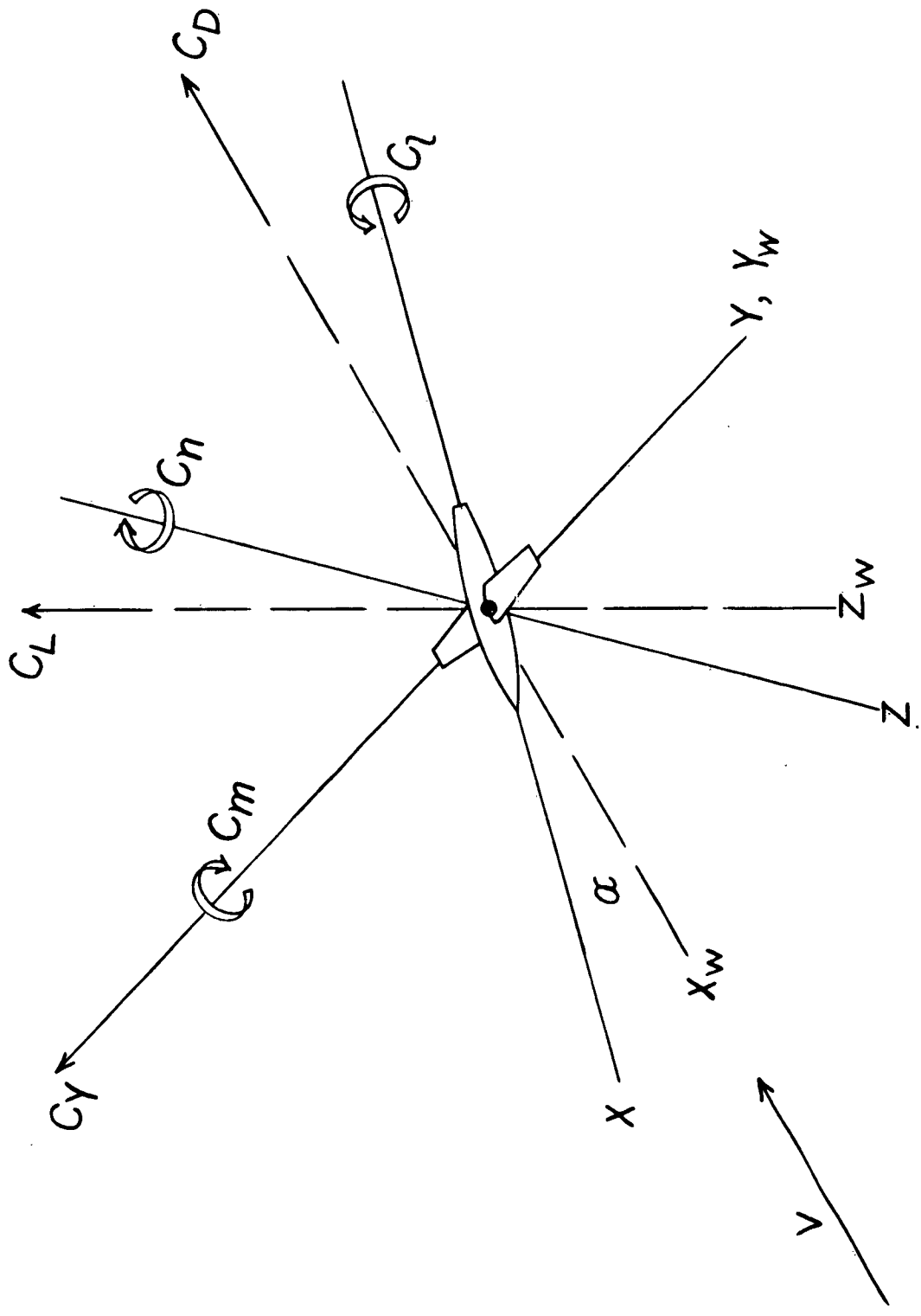


Figure 1.- Systems of axes used. Positive directions of forces and moments are indicated by arrows.

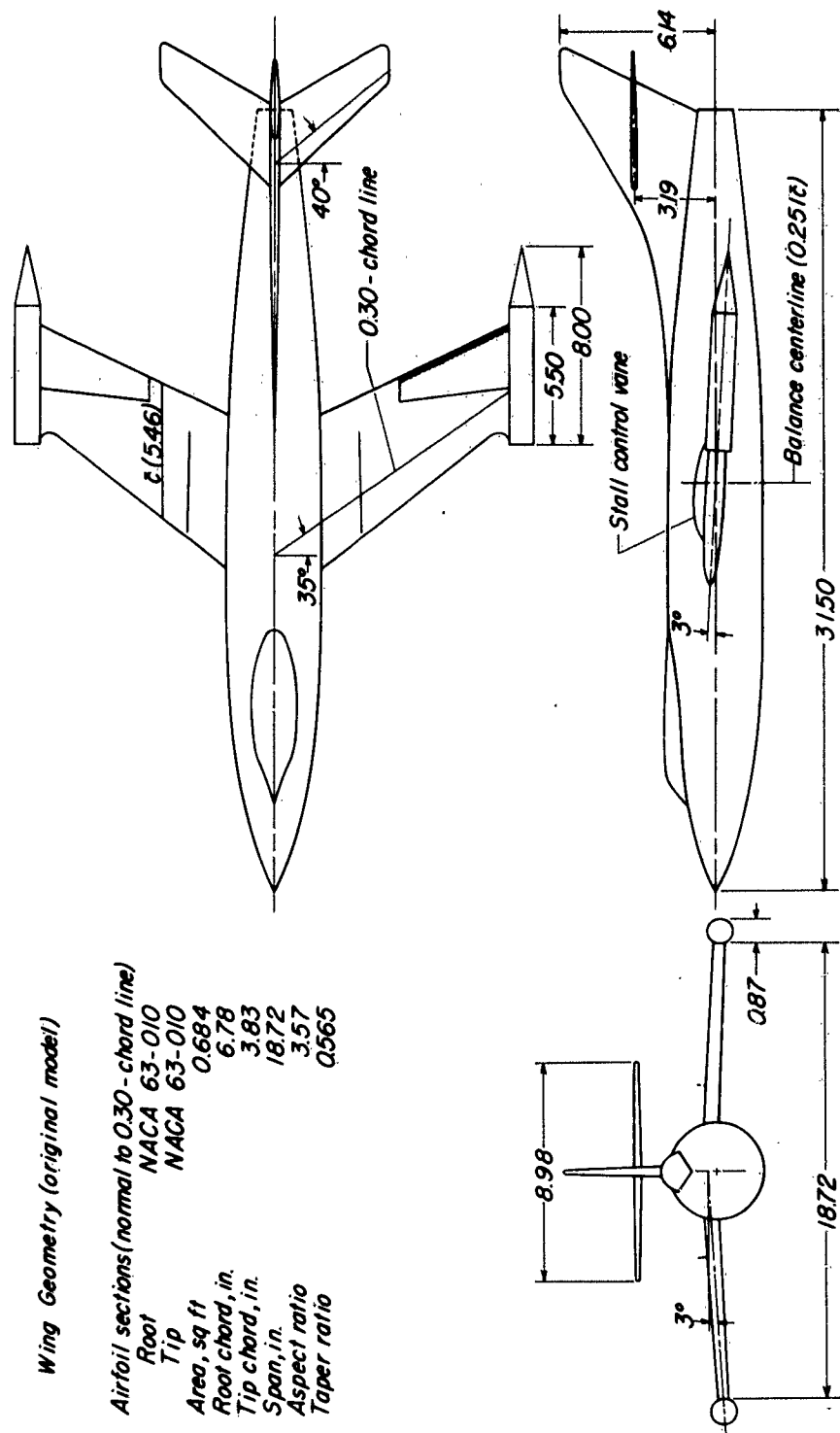
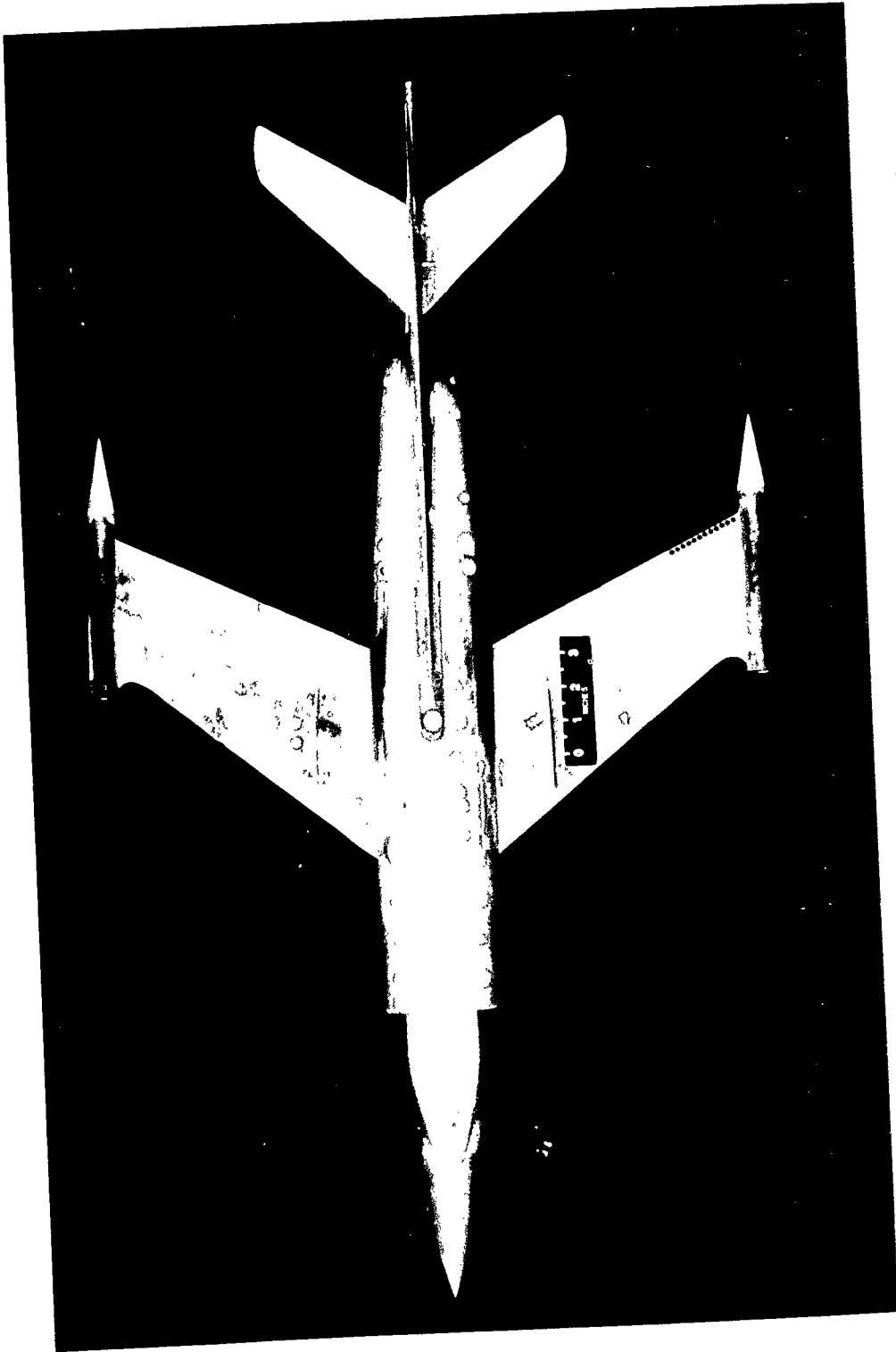
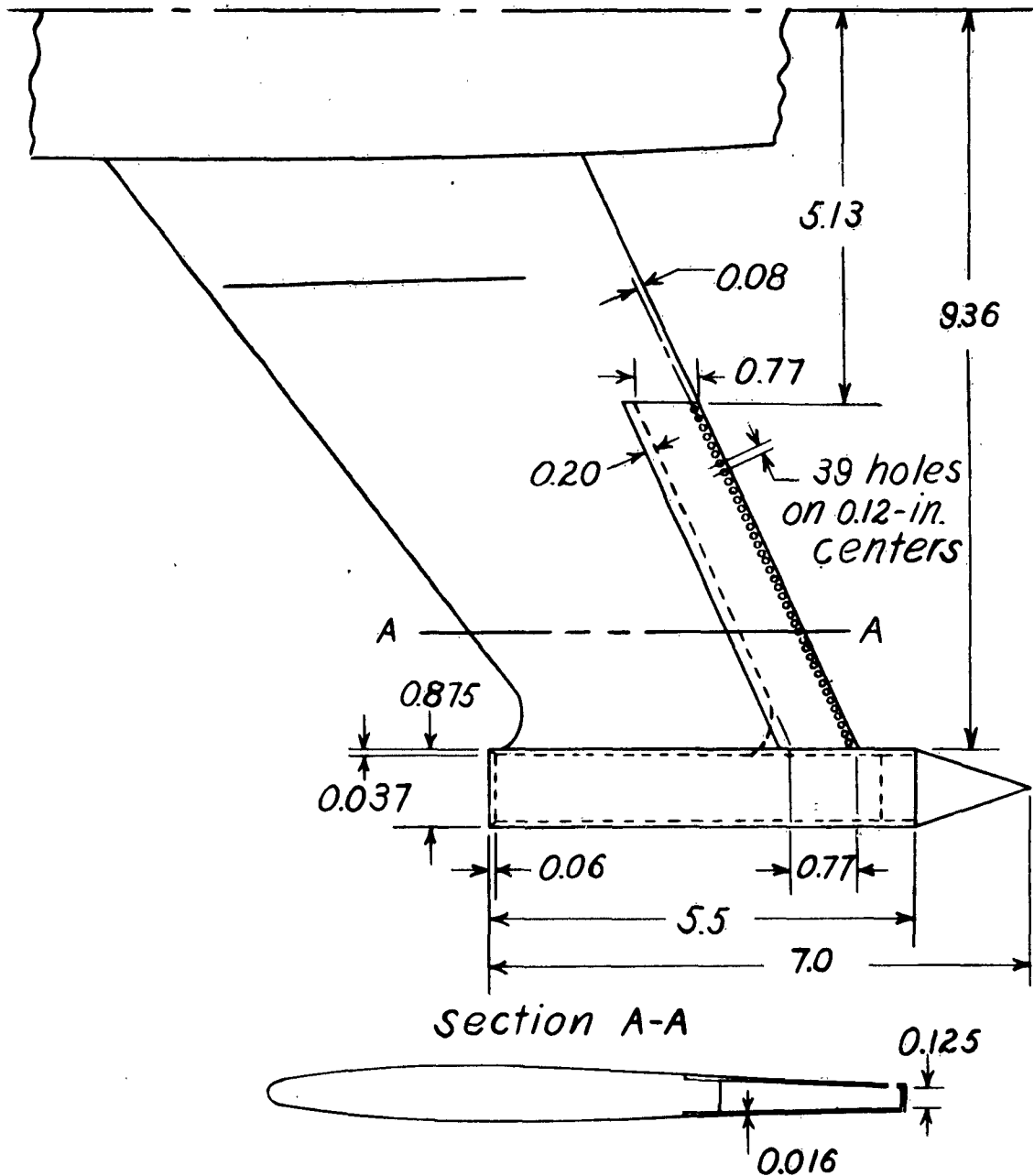


Figure 2.- Three-view drawing of model with large plenum chamber in wing.
All dimensions in inches unless noted.

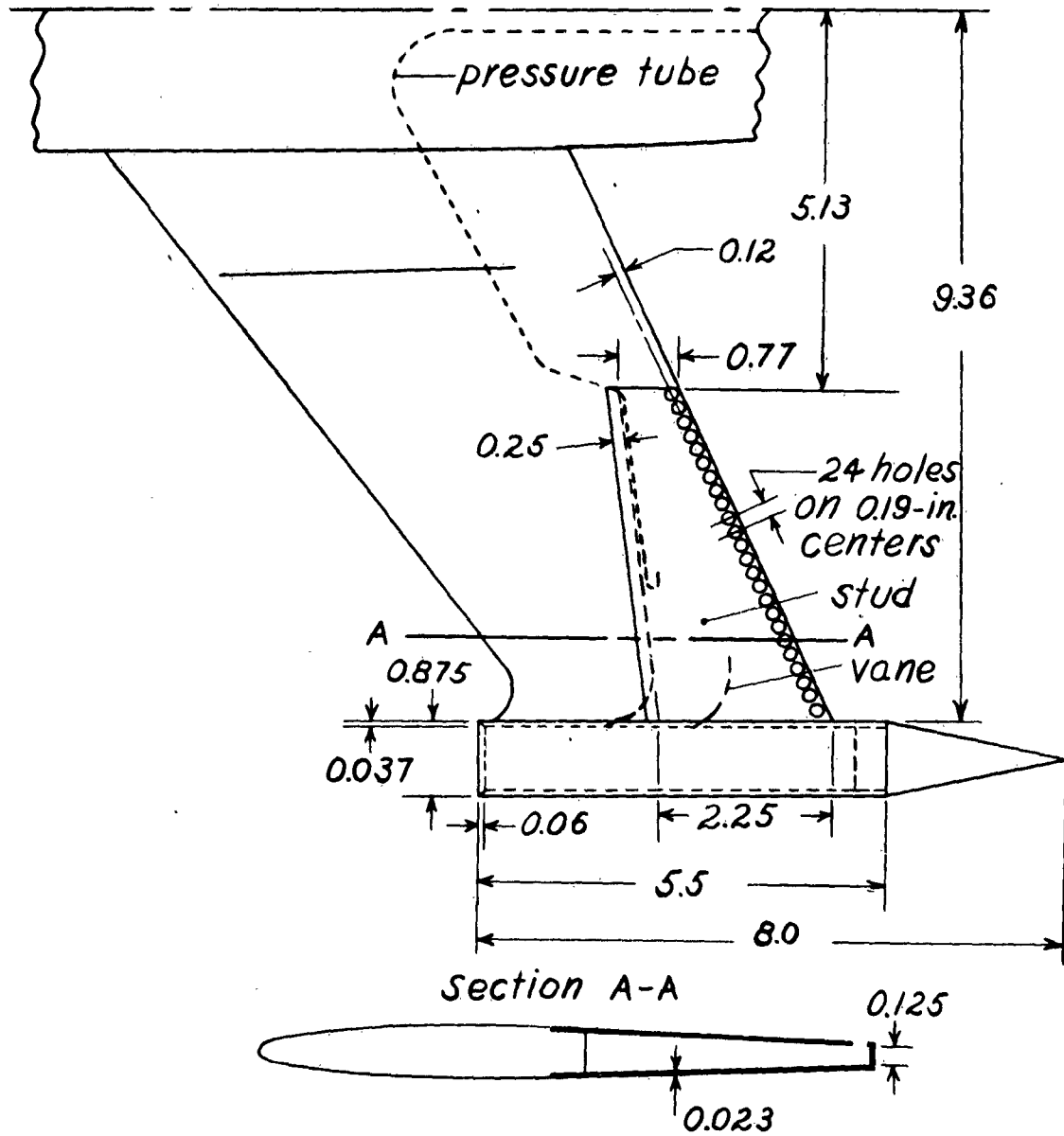


L-89567
Figure 3.- Photograph of model with 0.172-inch-diameter jet holes and large plenum chamber.



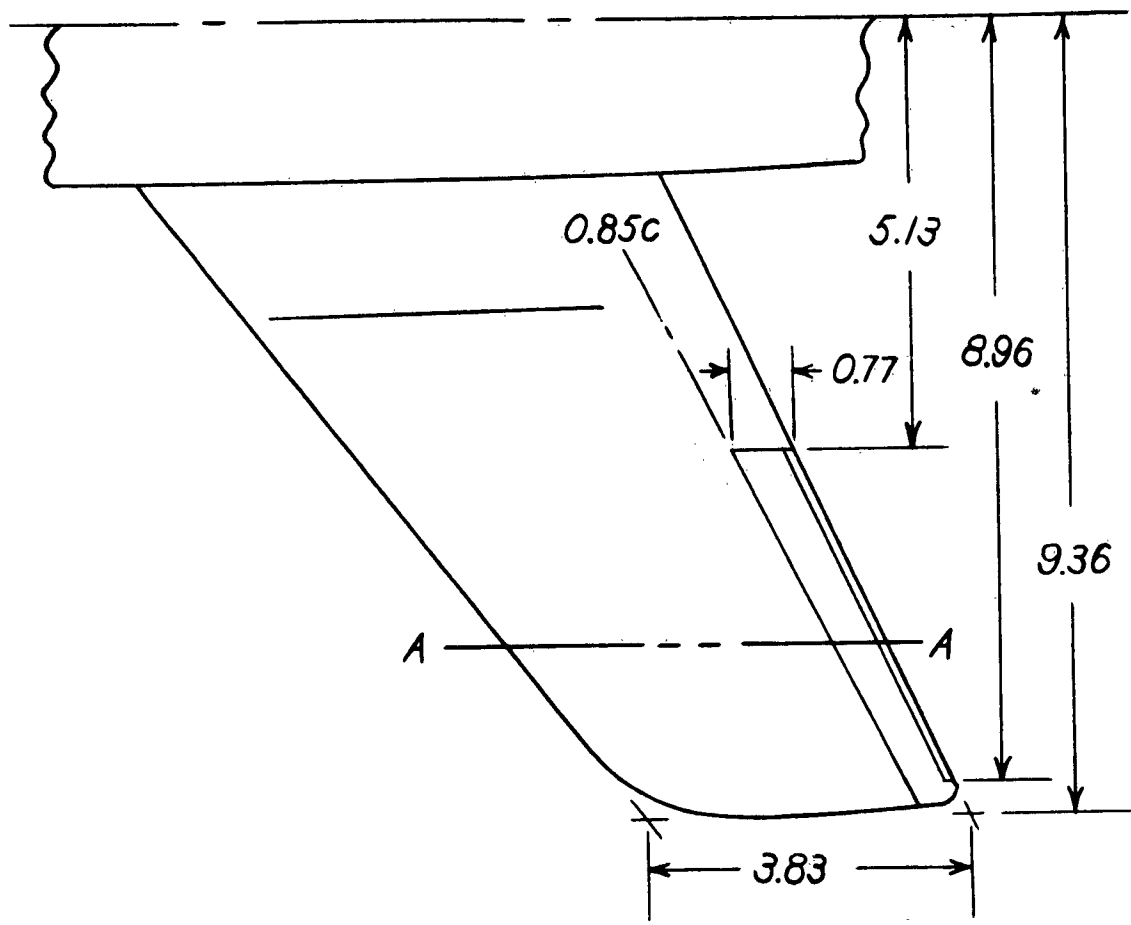
(a) Small plenum chamber.

Figure 4.- Details of jet controls. All dimensions are in inches.



(b) Large plenum chamber.

Figure 4.- Concluded.

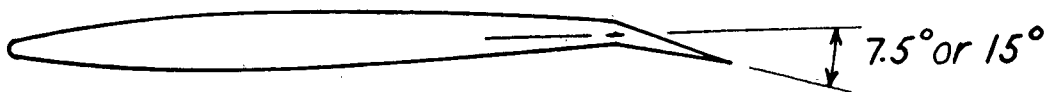


sections A-A

Plain wing



Ailerons



Spoilers



Figure 5.- Aileron and spoiler details. All dimensions in inches.

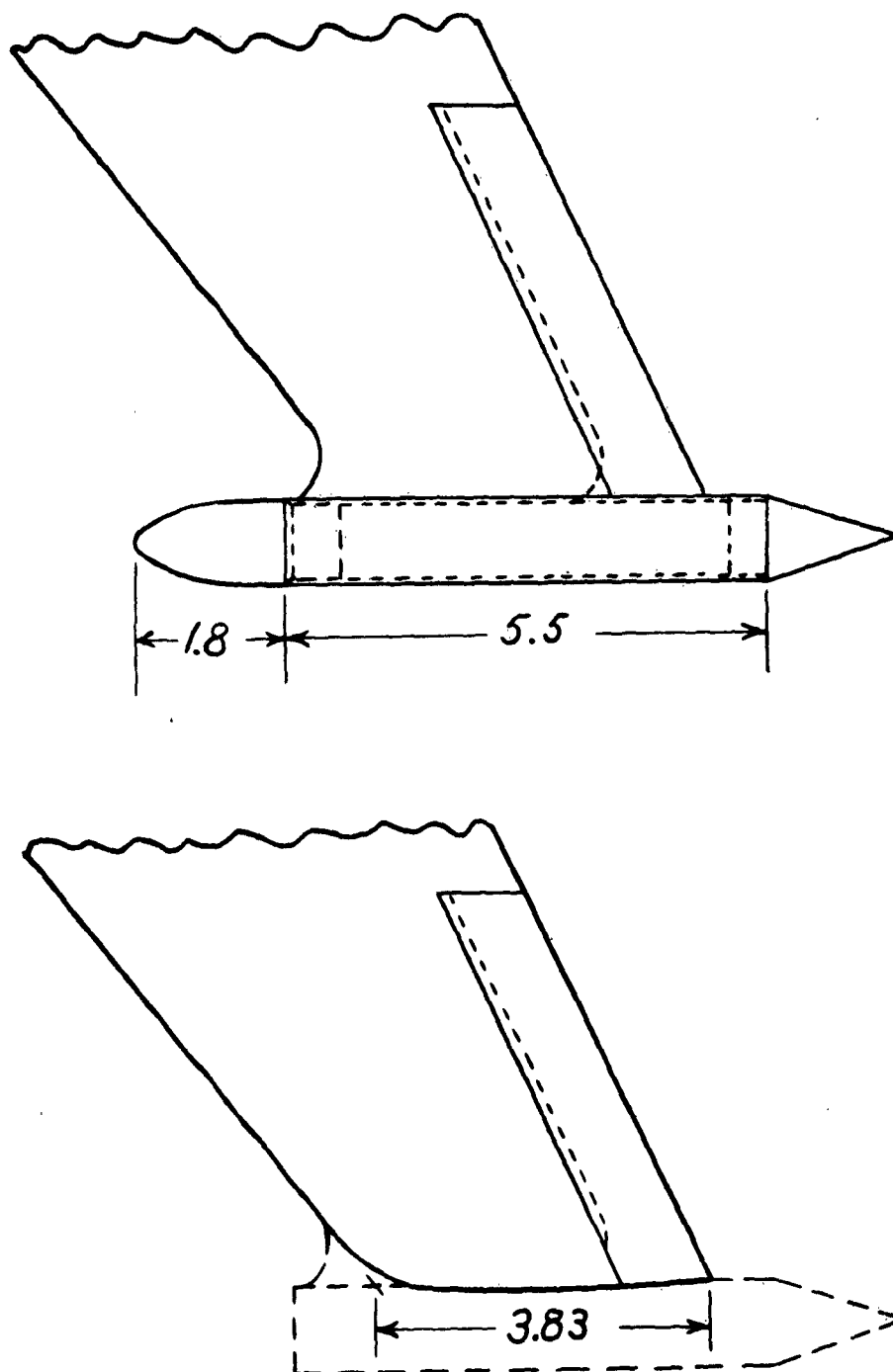
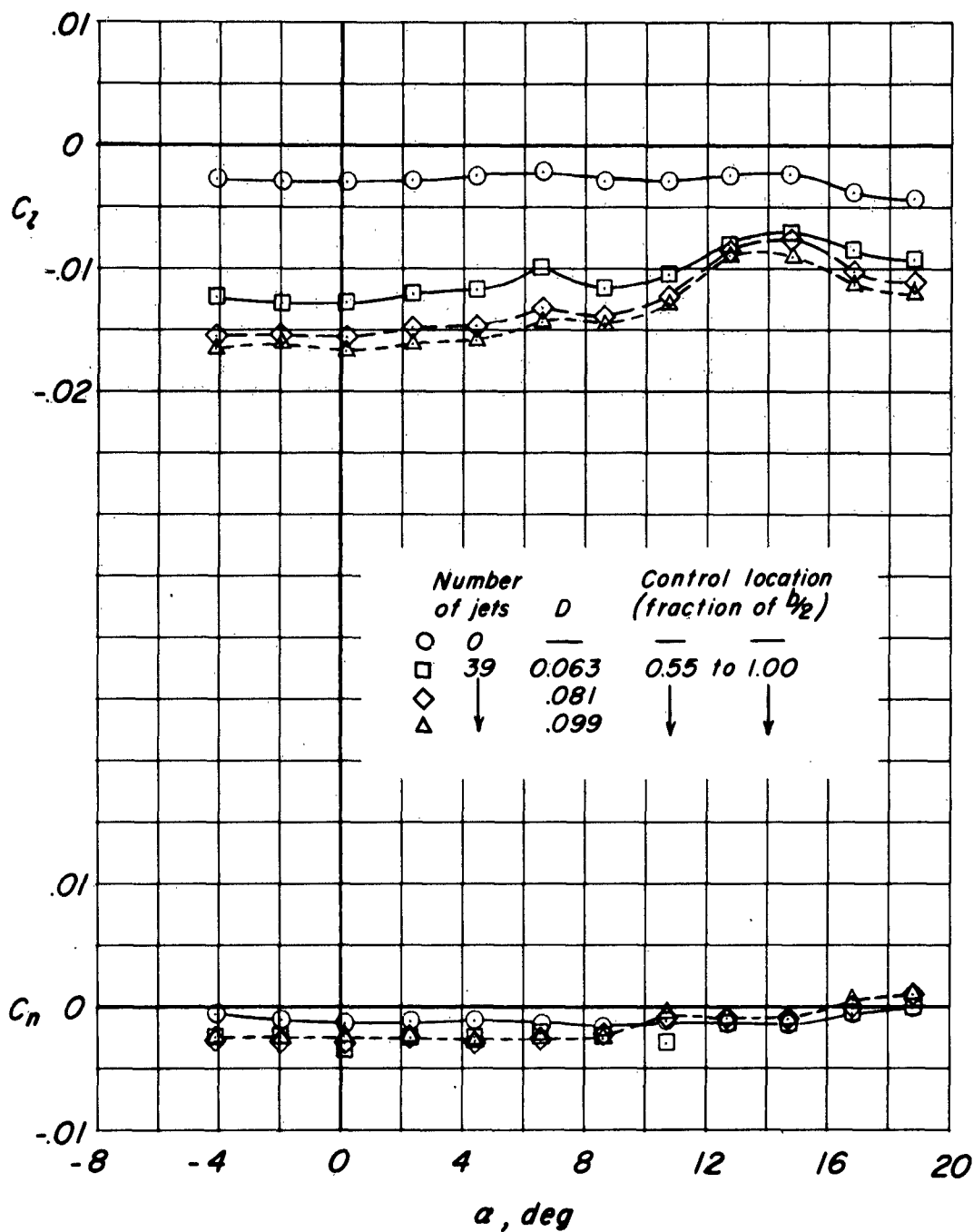


Figure 6.- Drawings of inlet plug, and of faired wing tip with the small plenum chamber attached and wing-tip inlets removed. All dimensions in inches.



(a) $M = 0.60$.

Figure 7.- Variation of rolling- and yawing-moment coefficients with angle of attack for wing with control-jet holes of three diameters in the small plenum chamber.

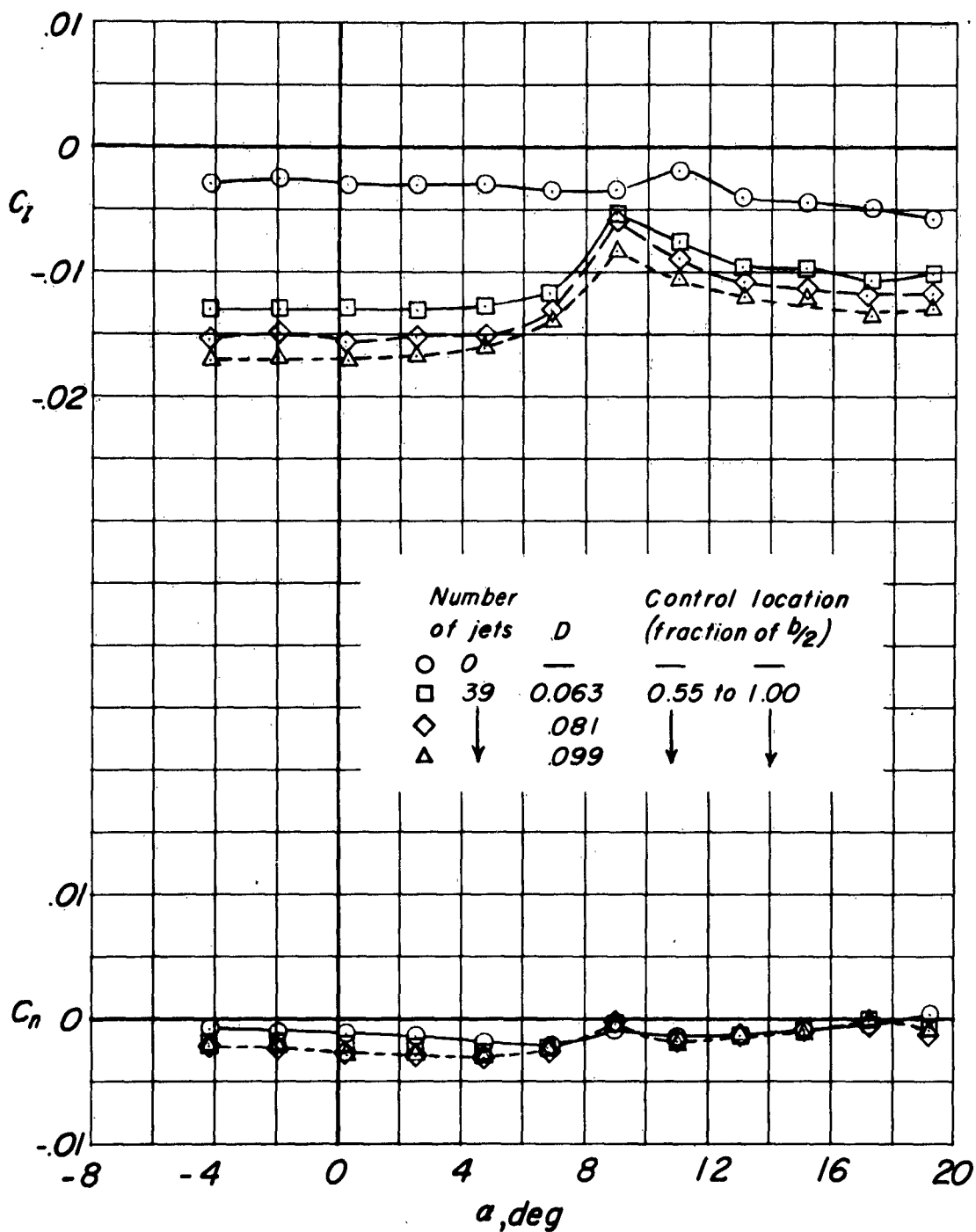
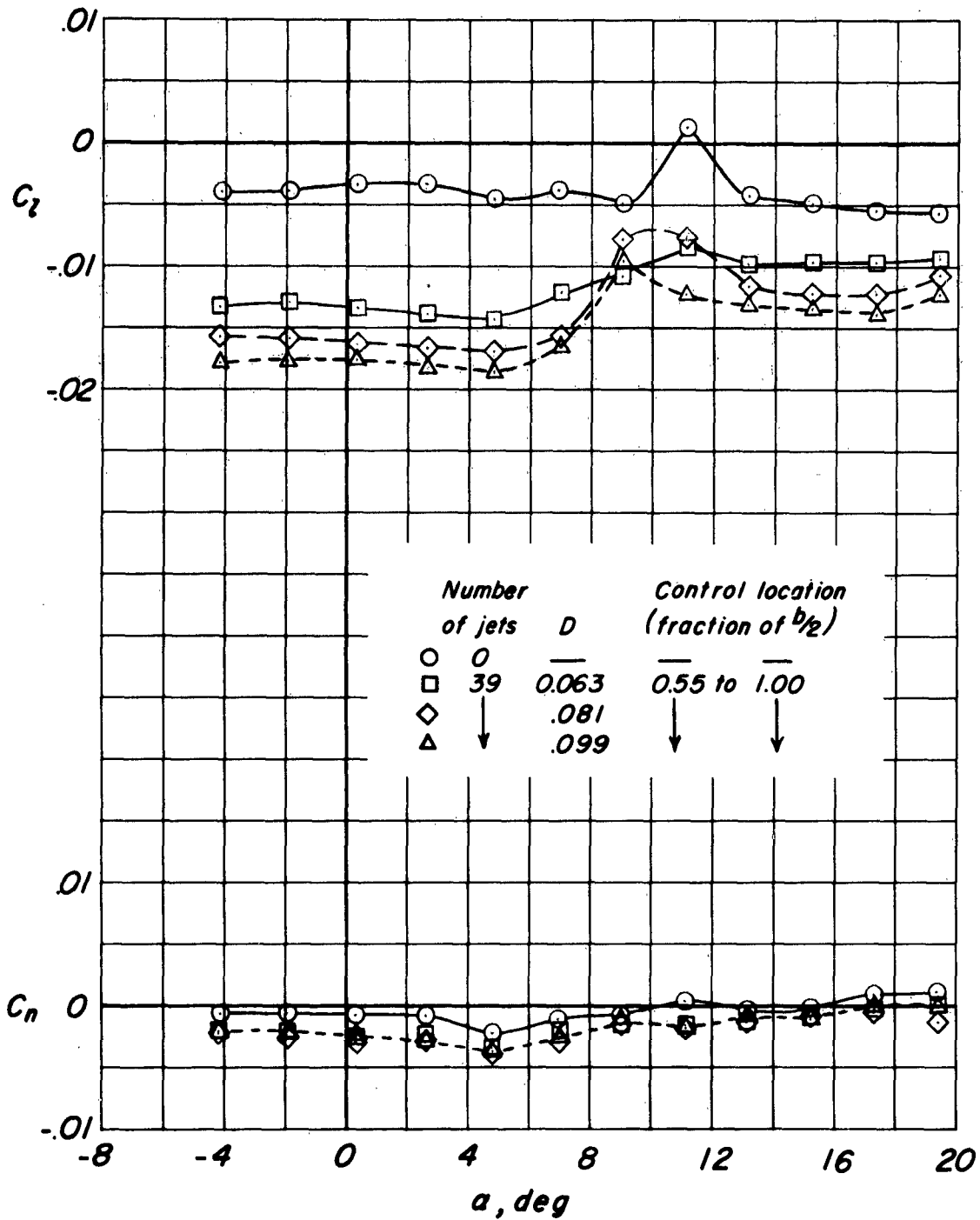
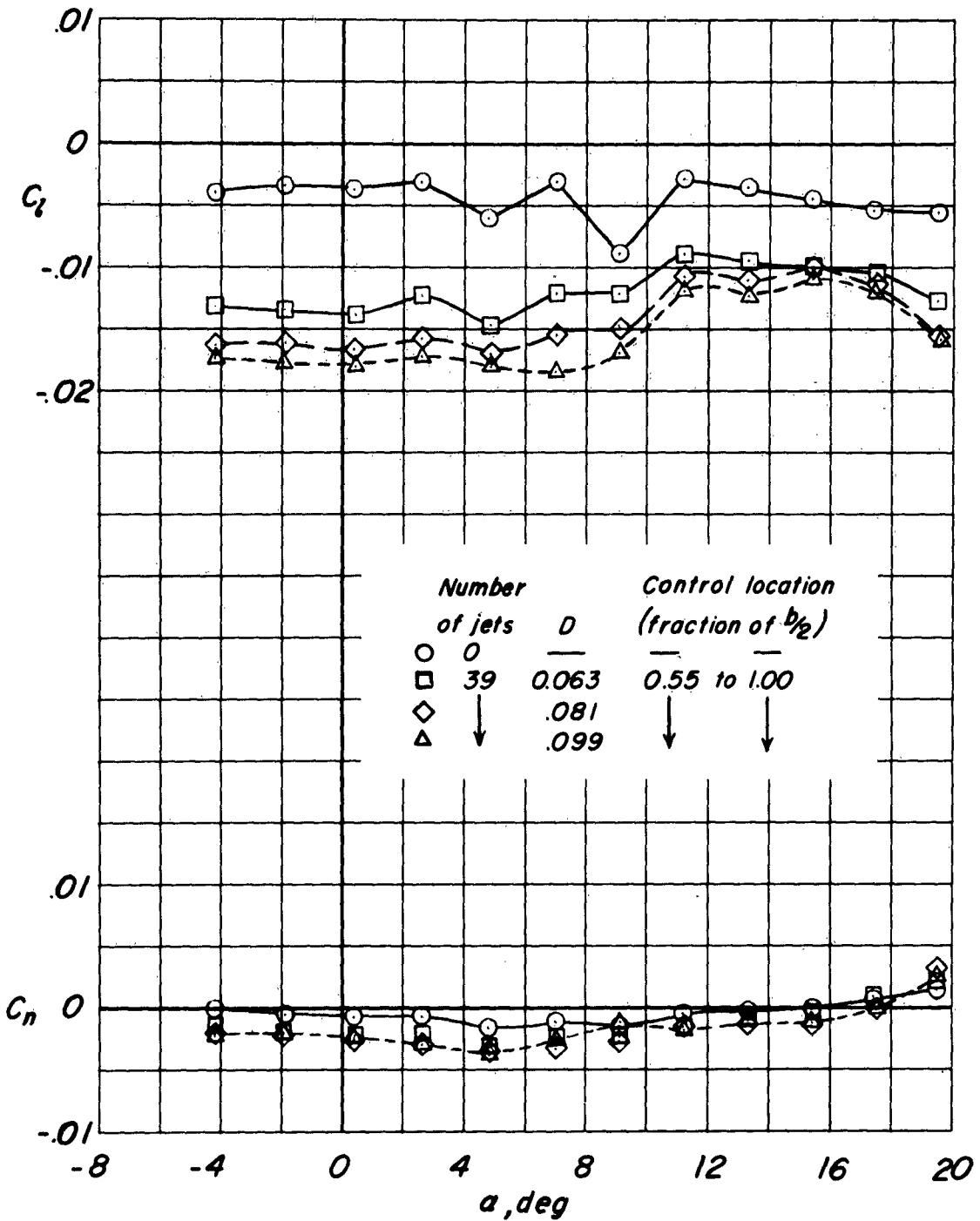
(b) $M = 0.80$.

Figure 7.- Continued.



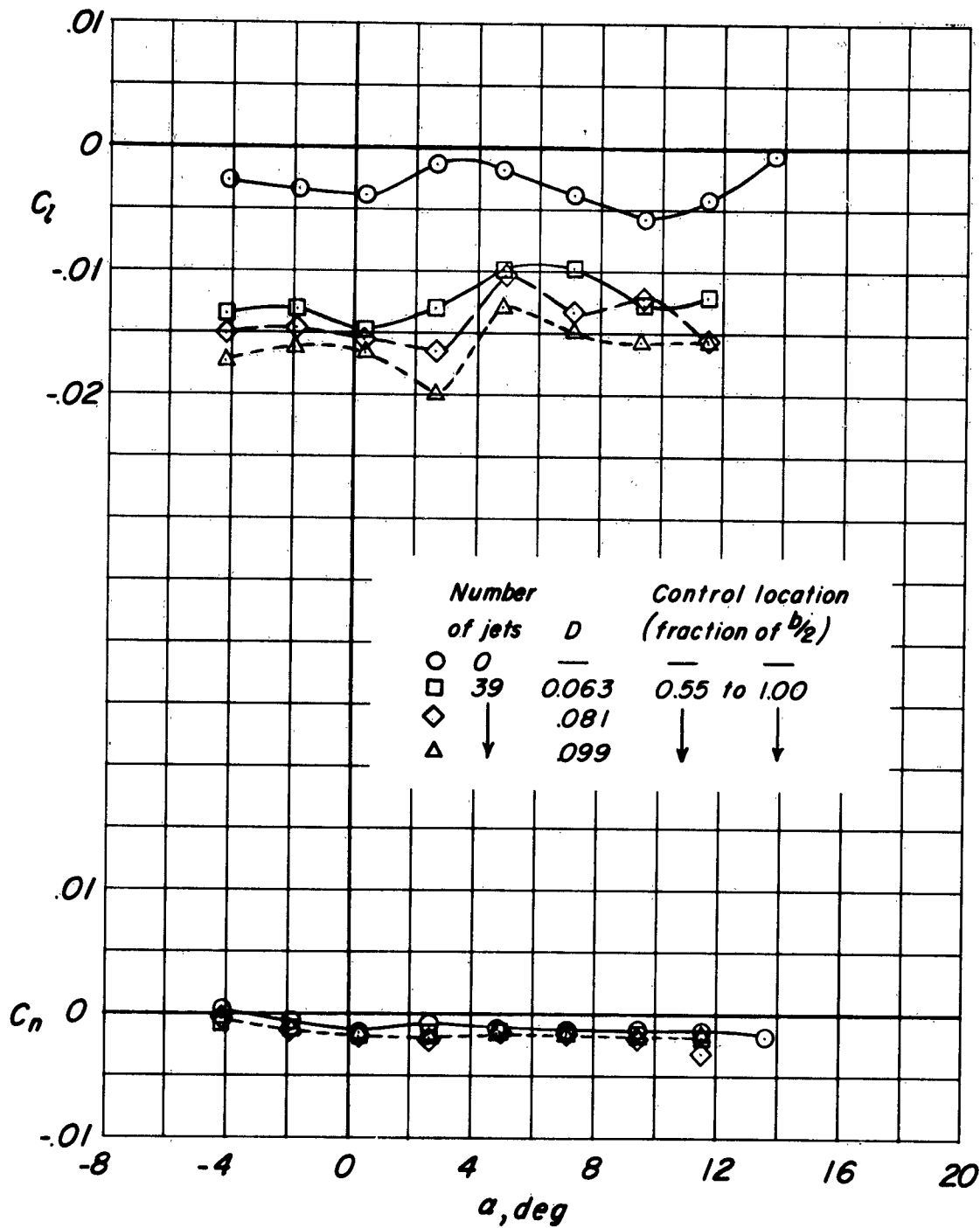
(c) $M = 0.85$.

Figure 7.- Continued.



(d) $M = 0.90$.

Figure 7.- Continued.



(e) $M = 0.96$.

Figure 7.- Concluded.

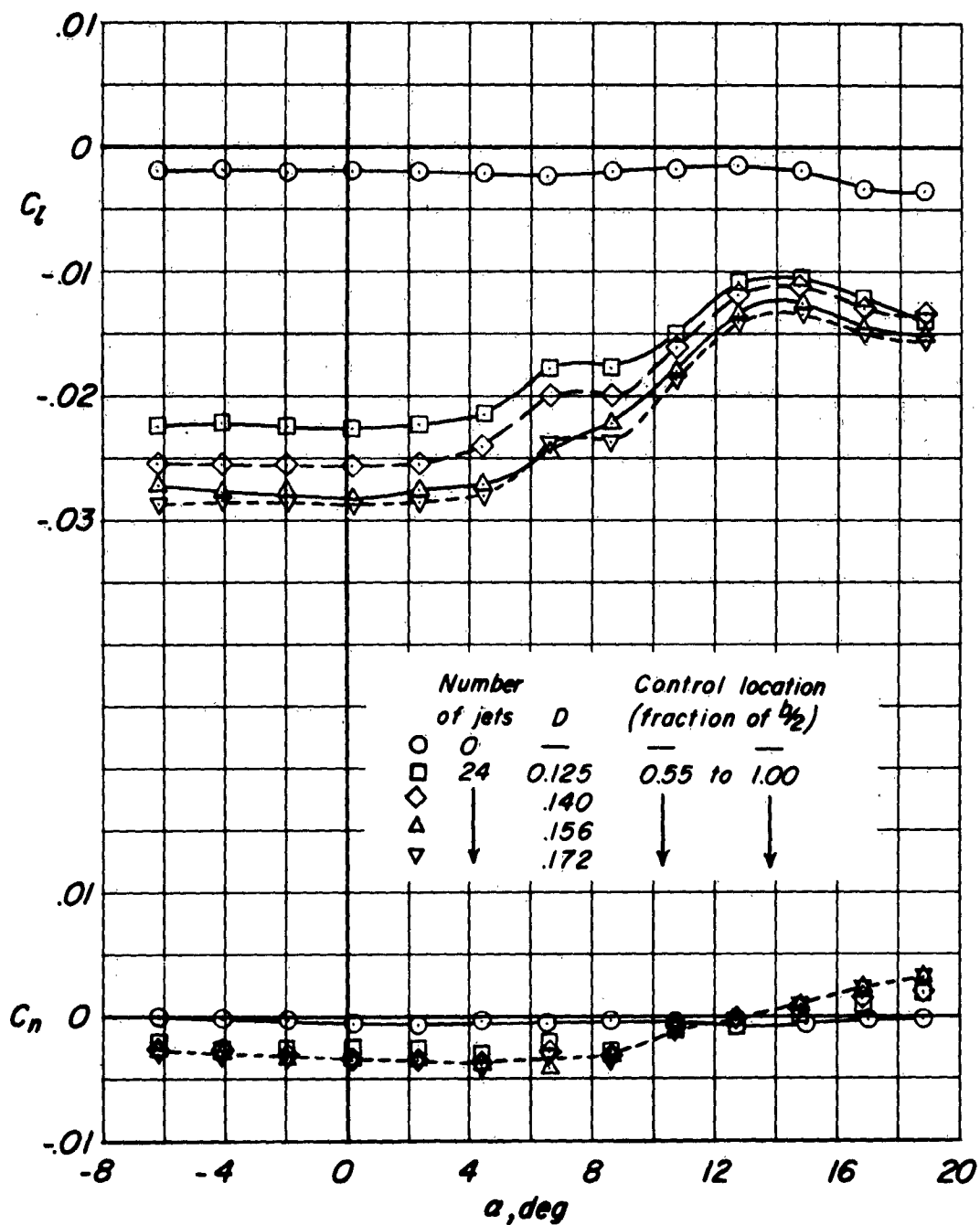
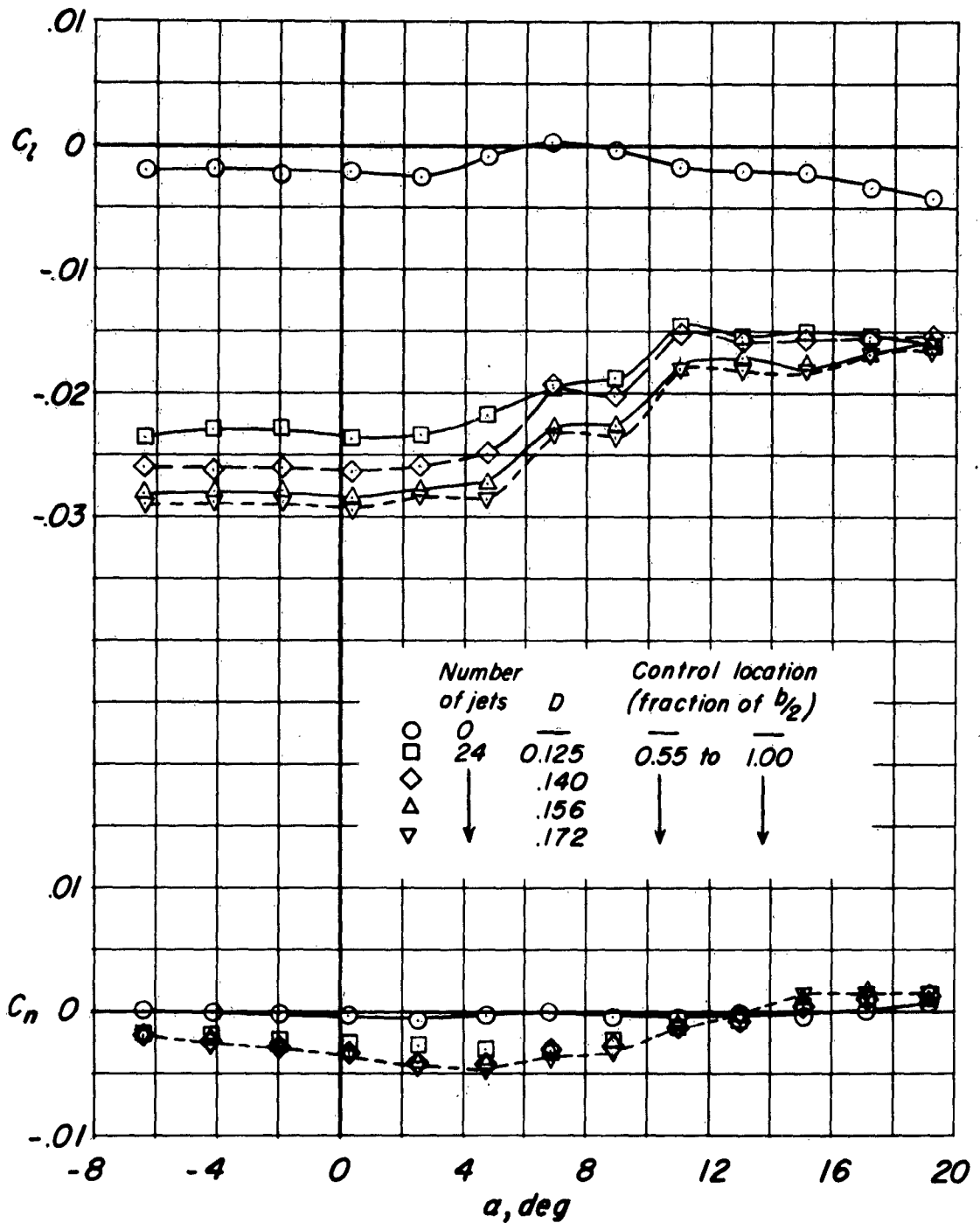
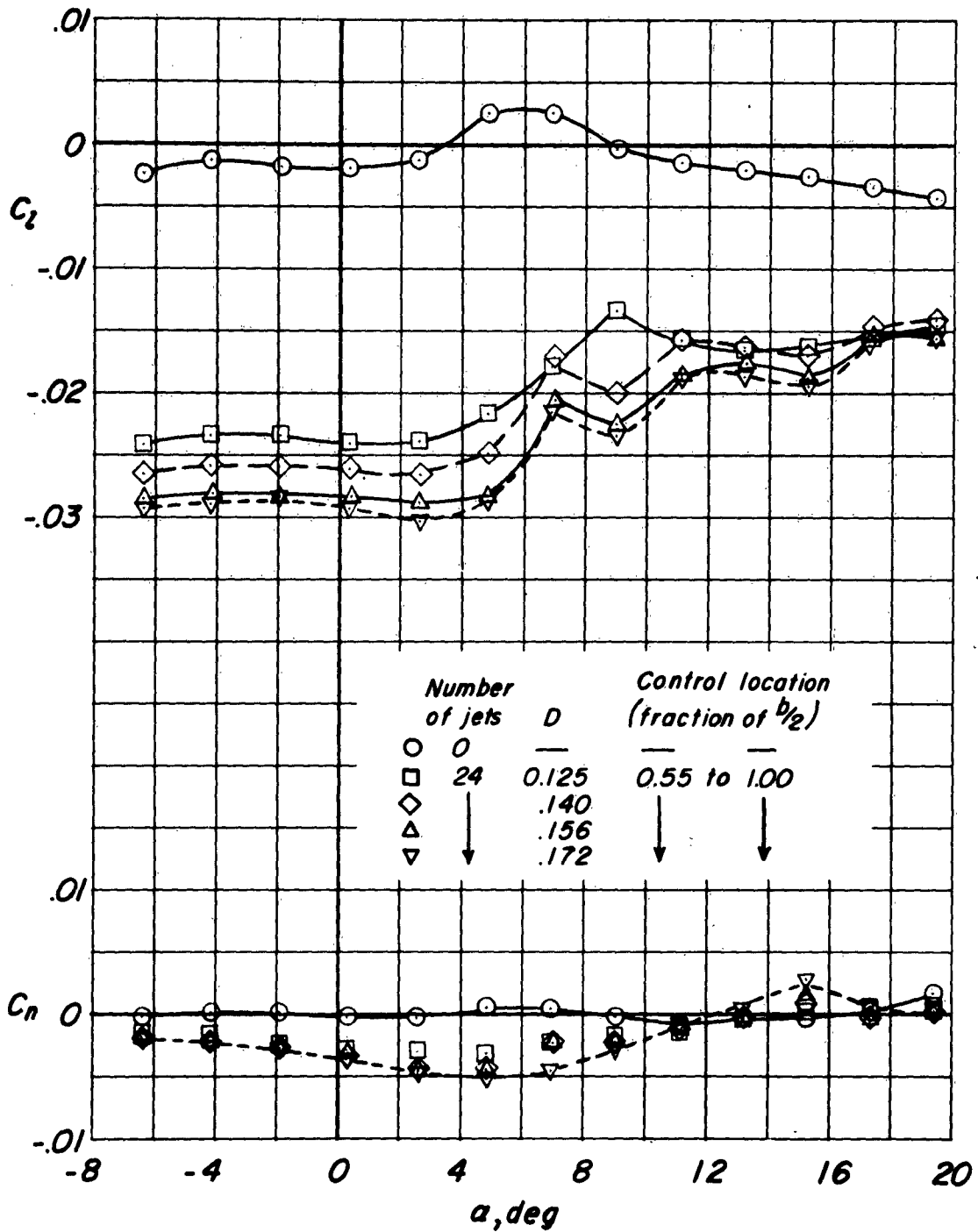
(a) $M = 0.60$.

Figure 8.- Variation of rolling- and yawing-moment coefficients with angle of attack for control-jet holes of four diameters in the large plenum chamber.



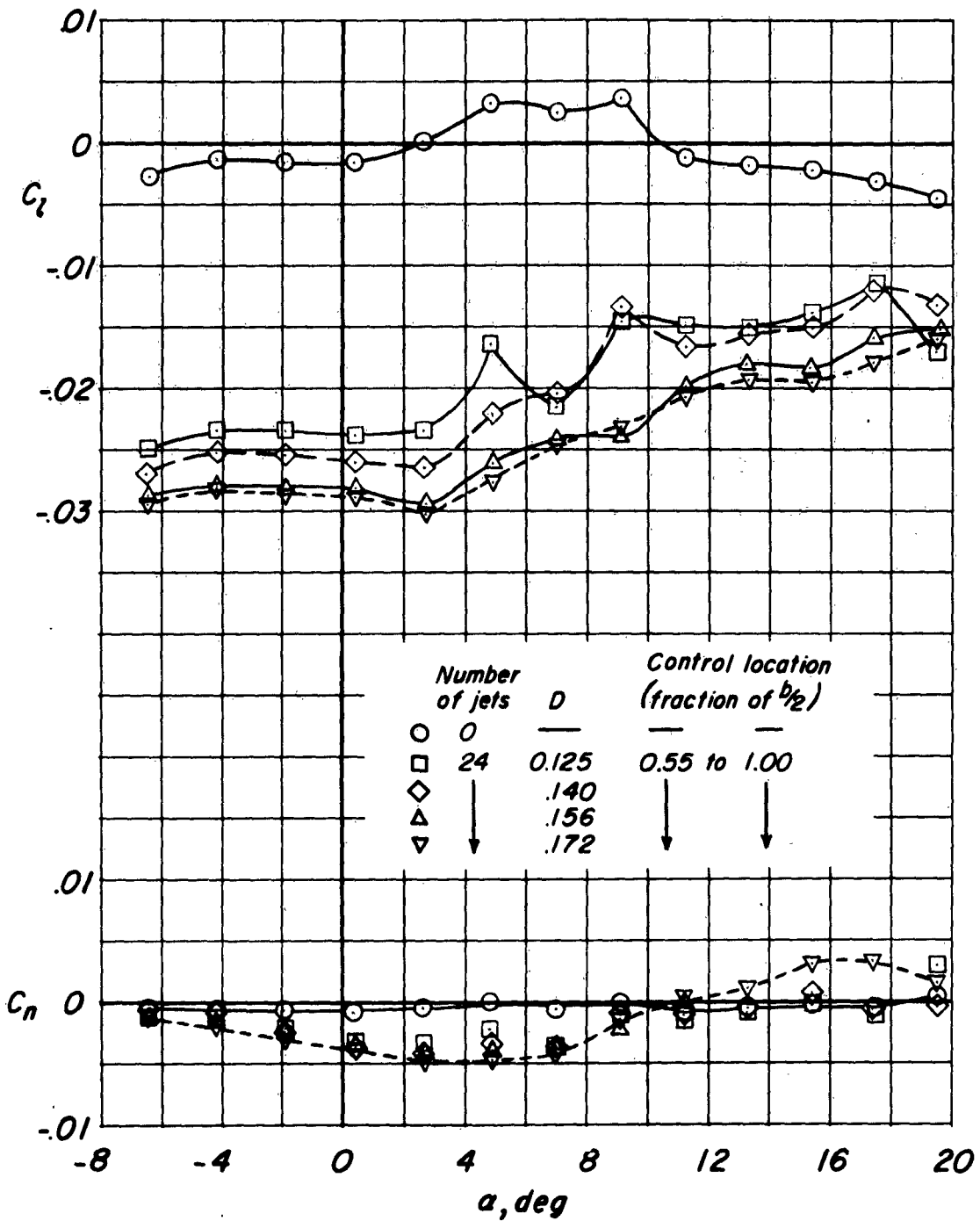
(b) $M = 0.80$.

Figure 8.- Continued.



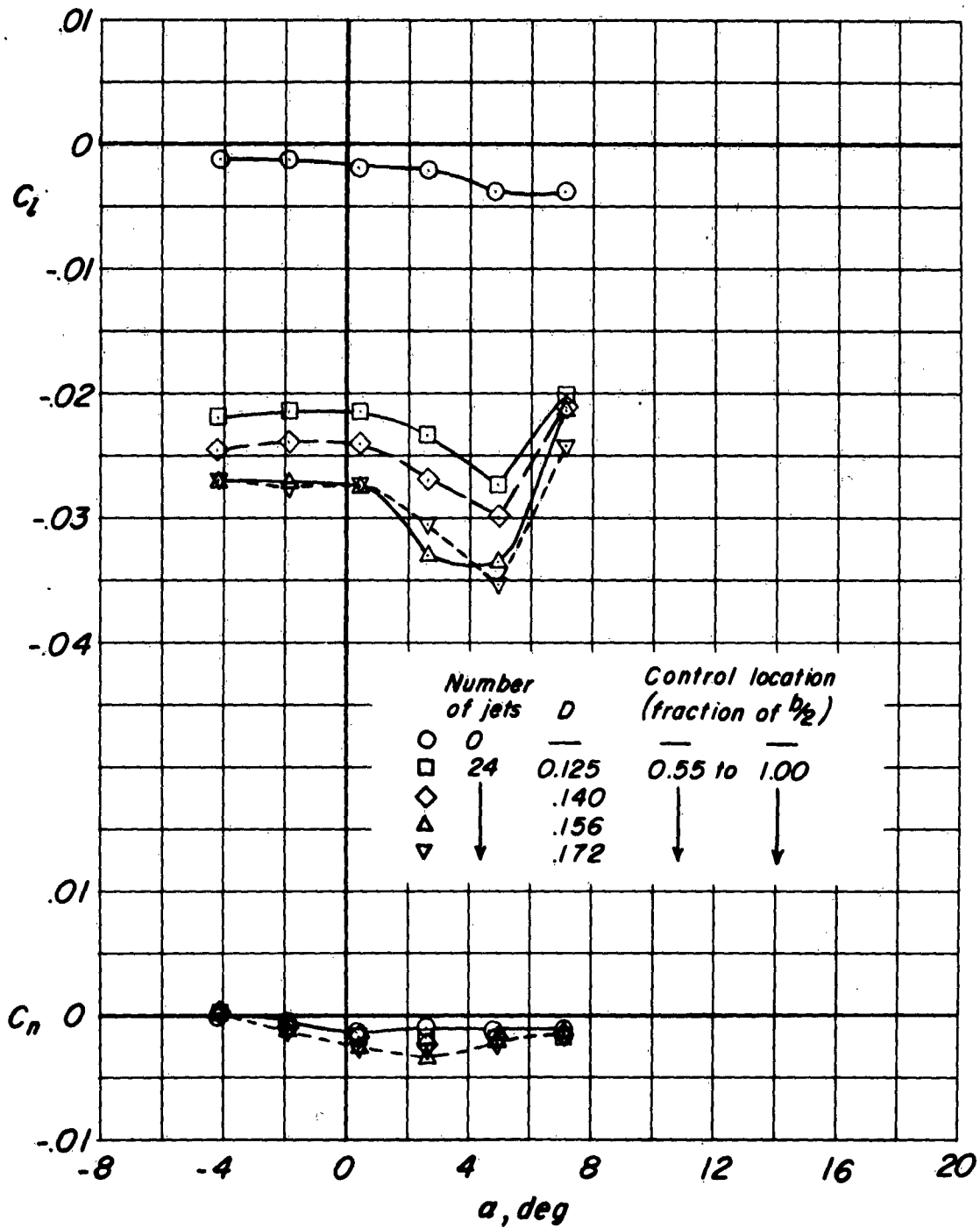
(c) $M = 0.85$.

Figure 8.- Continued.



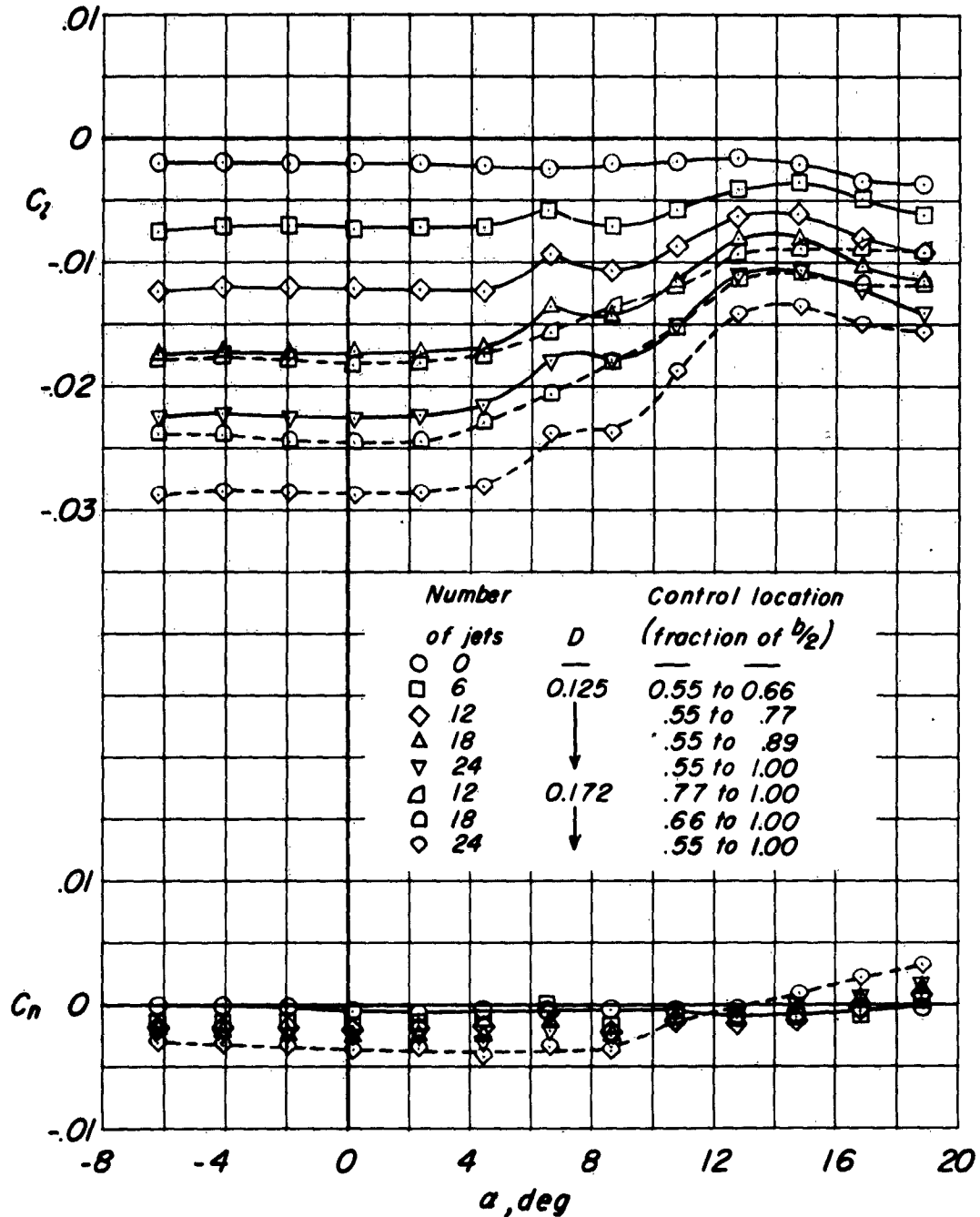
(d) $M = 0.90$.

Figure 8.- Continued.



(e) $M = 0.96$.

Figure 8.- Concluded.



(a) $M = 0.60$.

Figure 9.- Variation of rolling- and yawing-moment coefficients with angle of attack for wing with partial-span jet controls located inboard and outboard. Large plenum chamber.

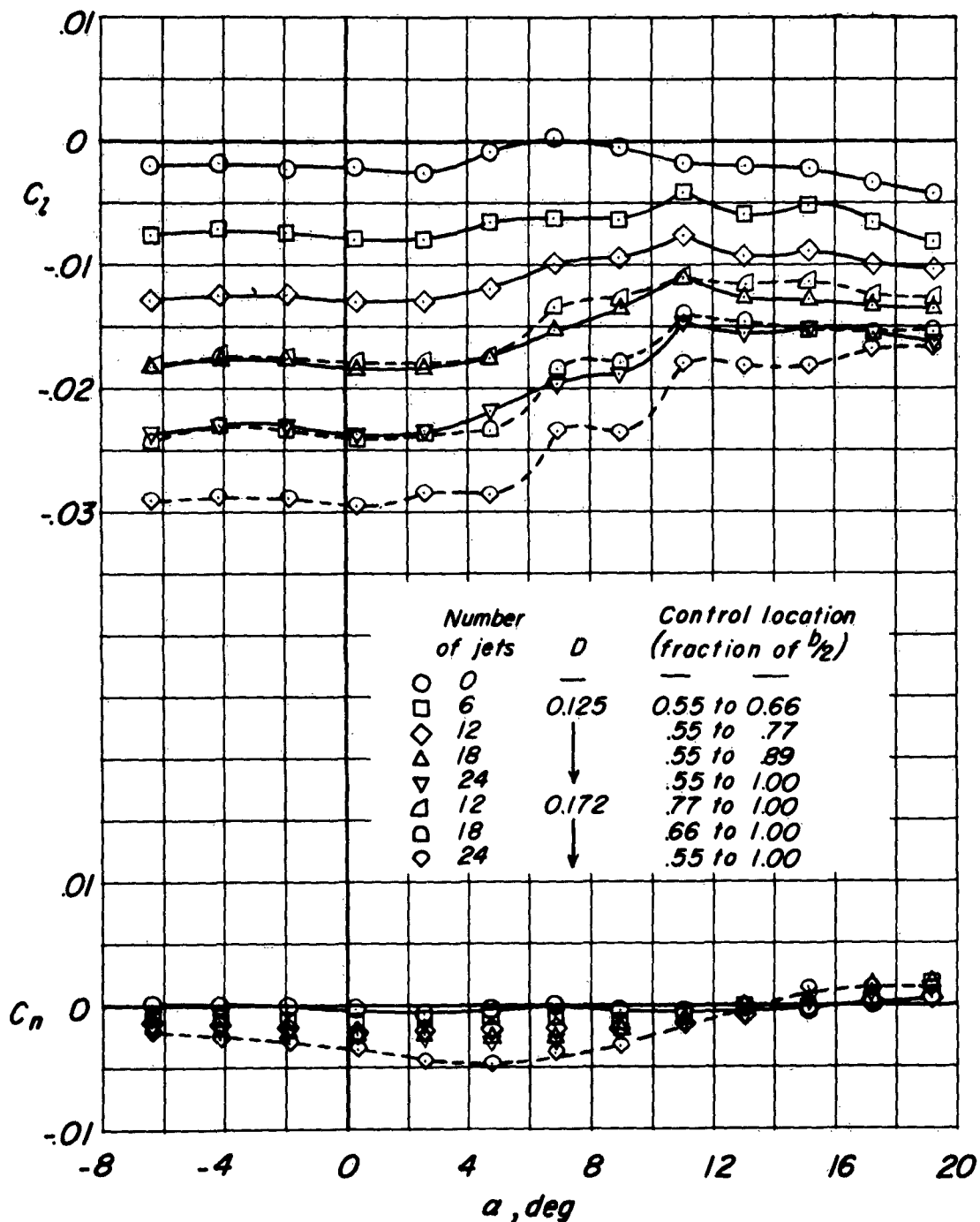
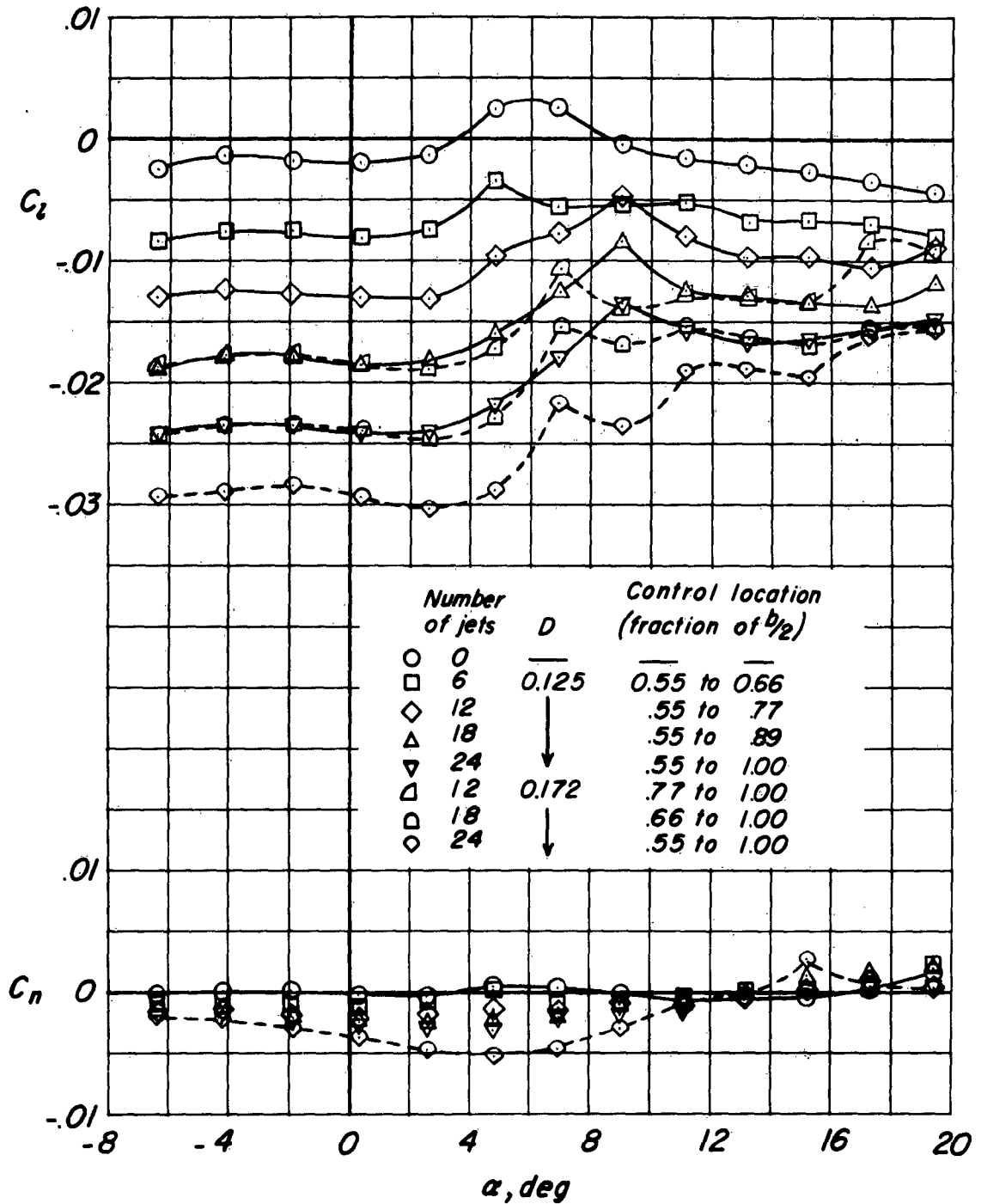
(b) $M = 0.80$.

Figure 9.- Continued.



(c) $M = 0.85$.

Figure 9.- Continued.

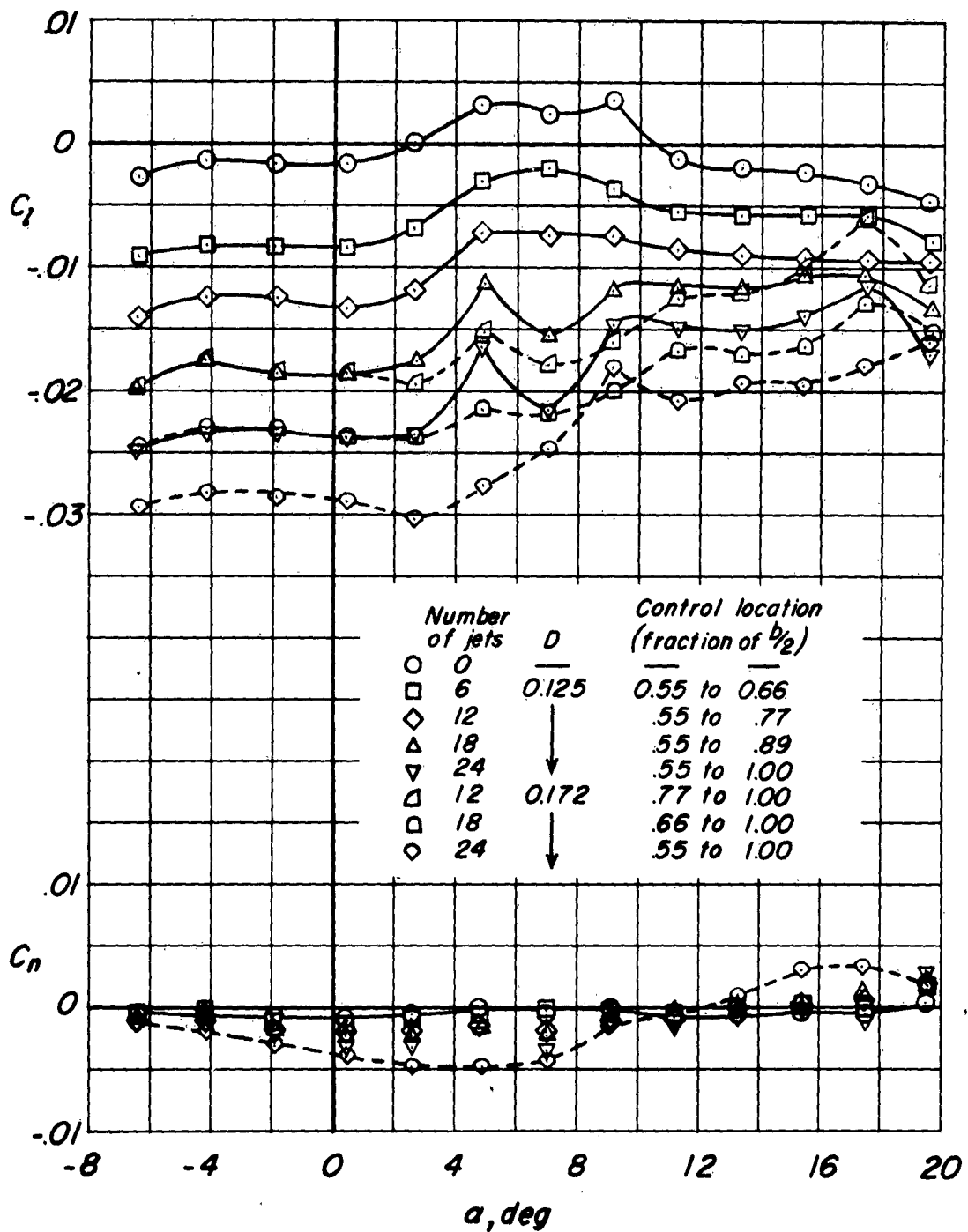
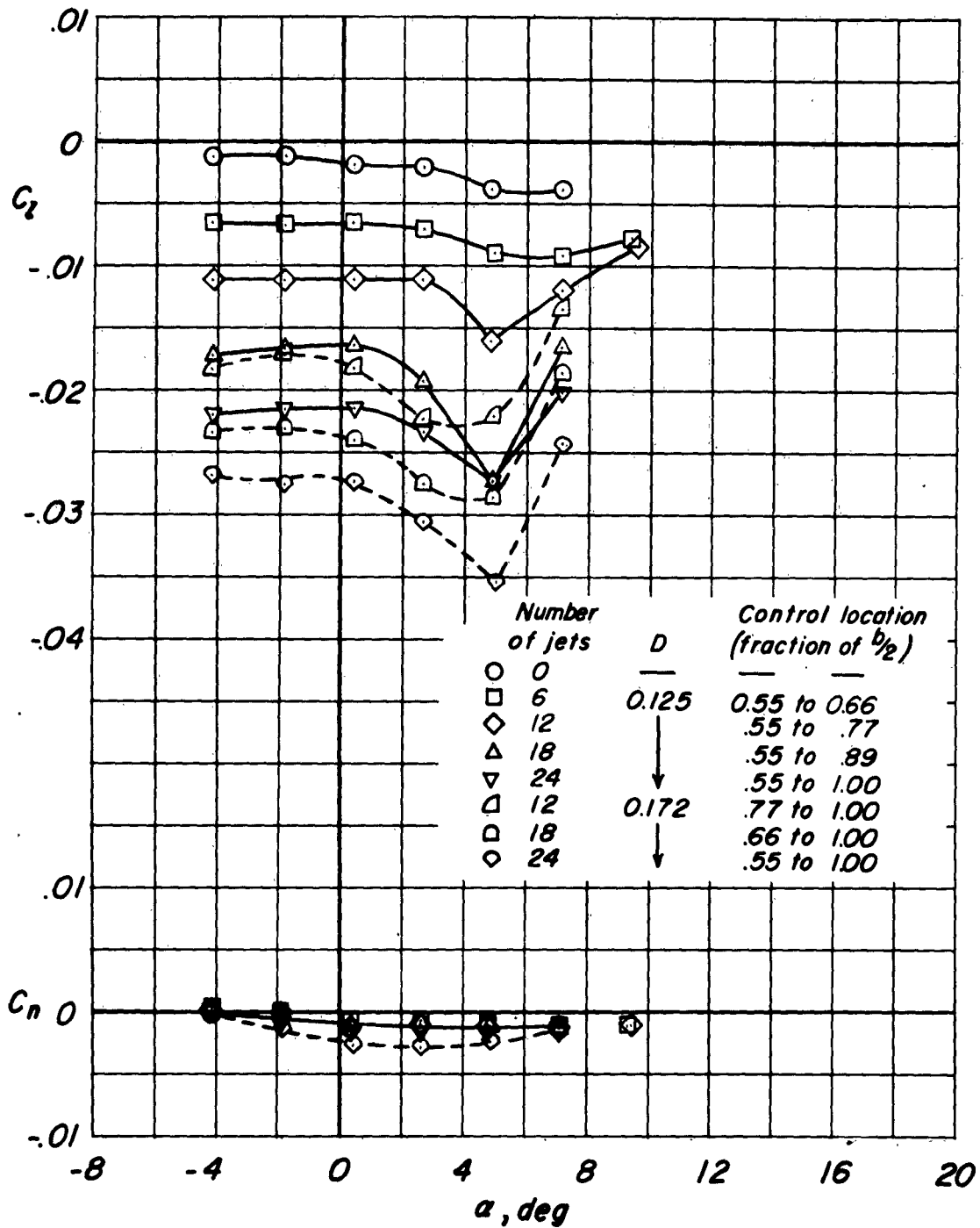
(d) $M = 0.90$.

Figure 9.- Continued.



(e) $M = 0.96$.

Figure 9.- Concluded.

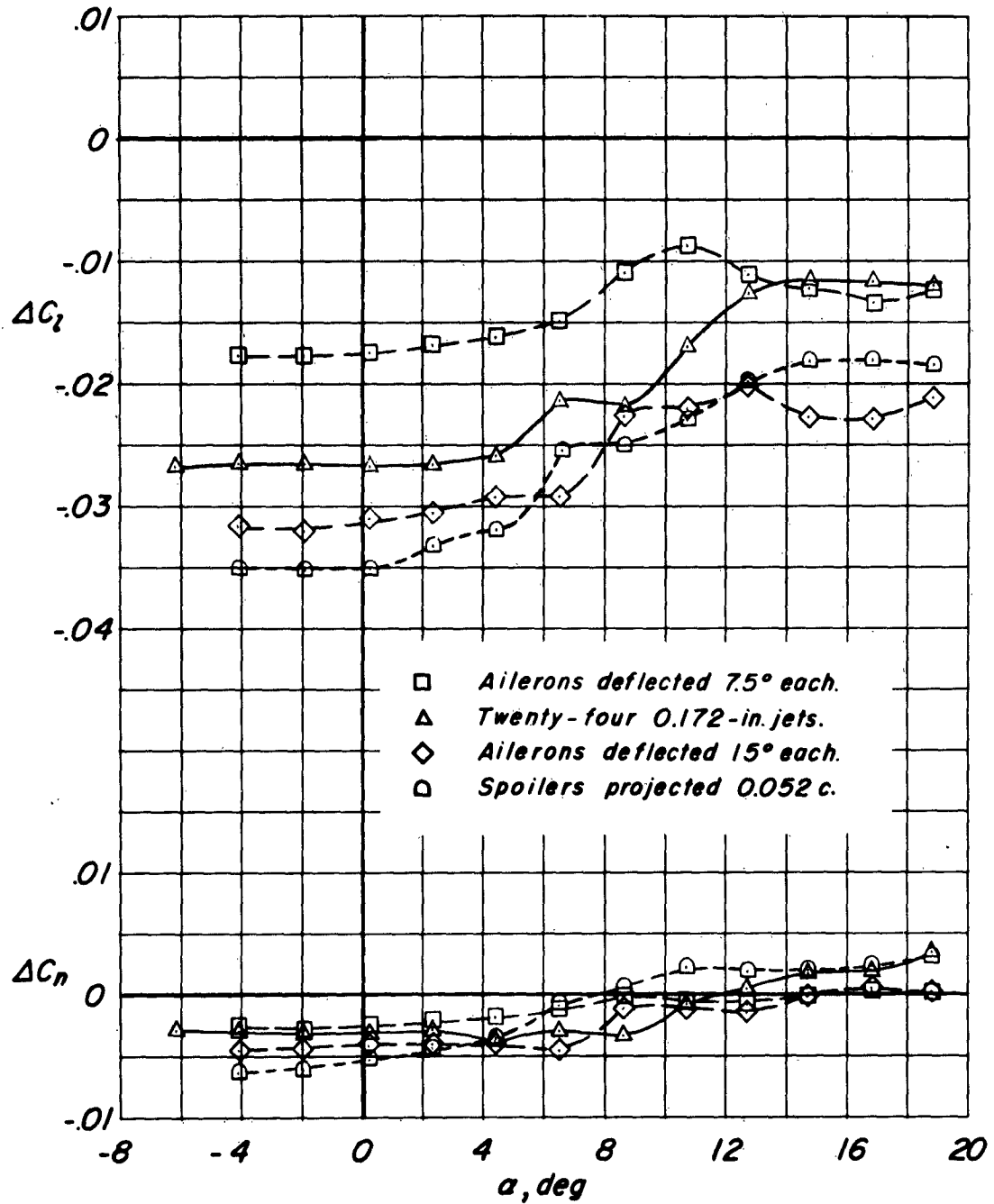
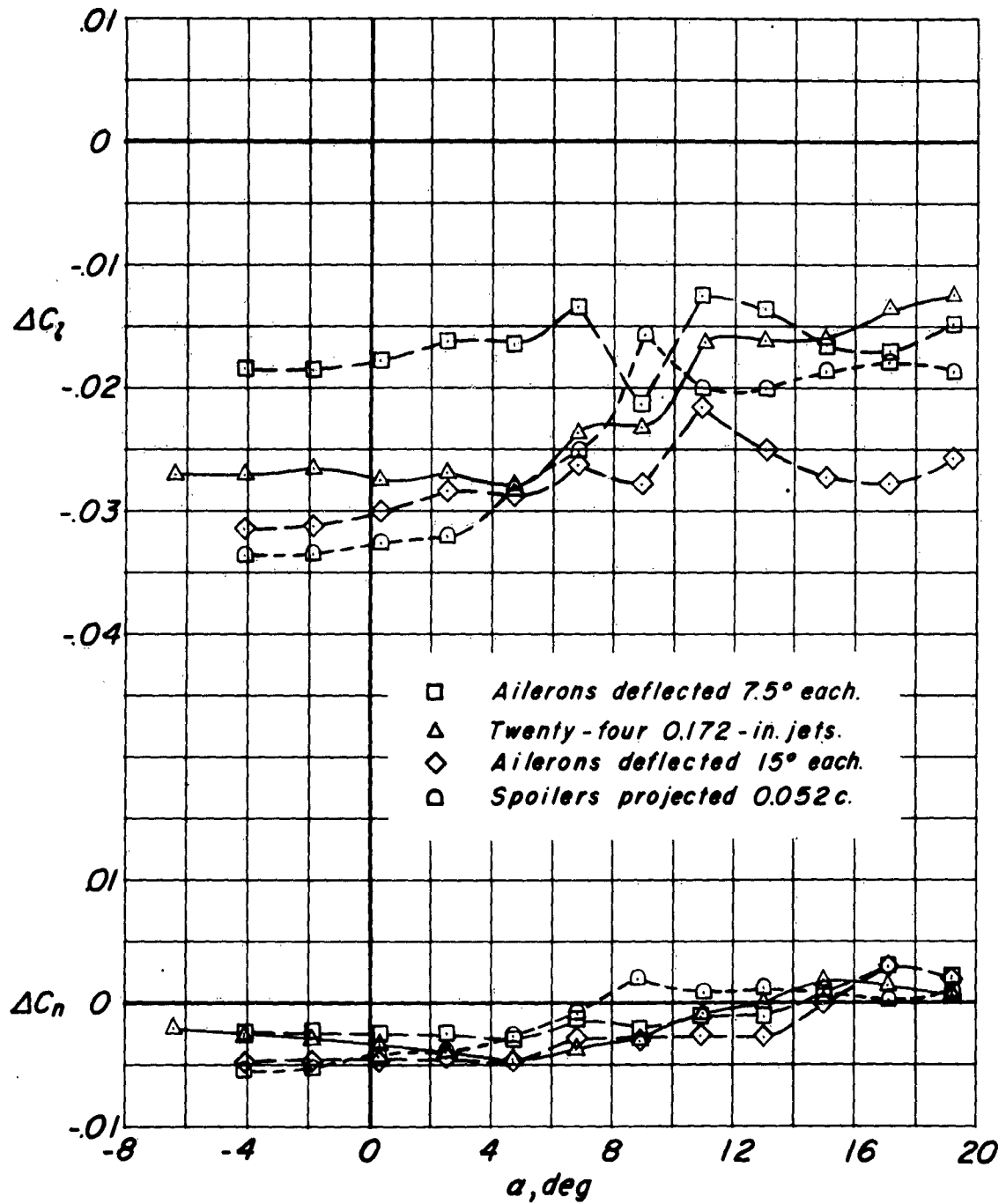
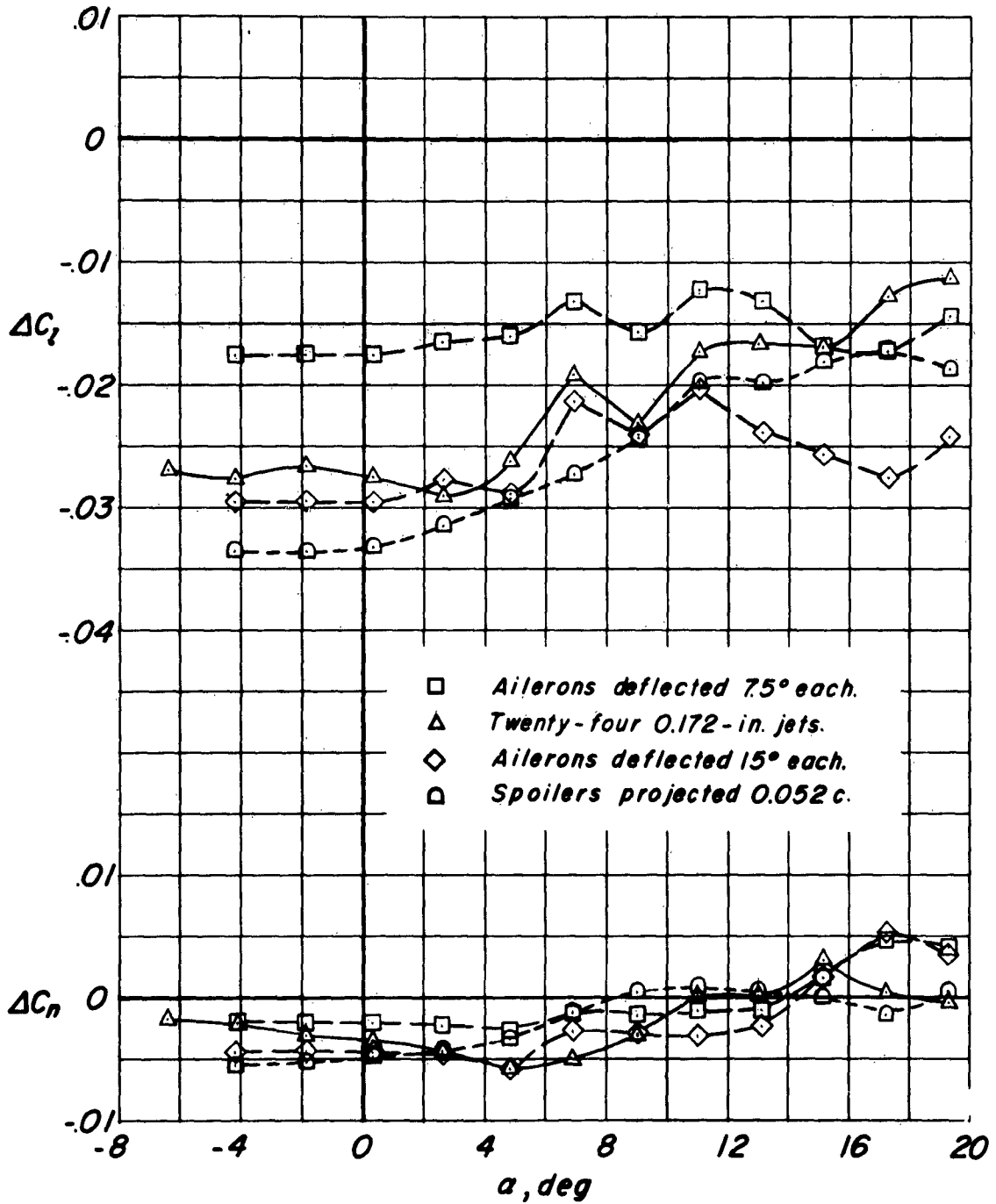
(a) $M = 0.60$.

Figure 10.- Comparison of rolling- and yawing-moment coefficients produced by jet, spoiler, and aileron controls.



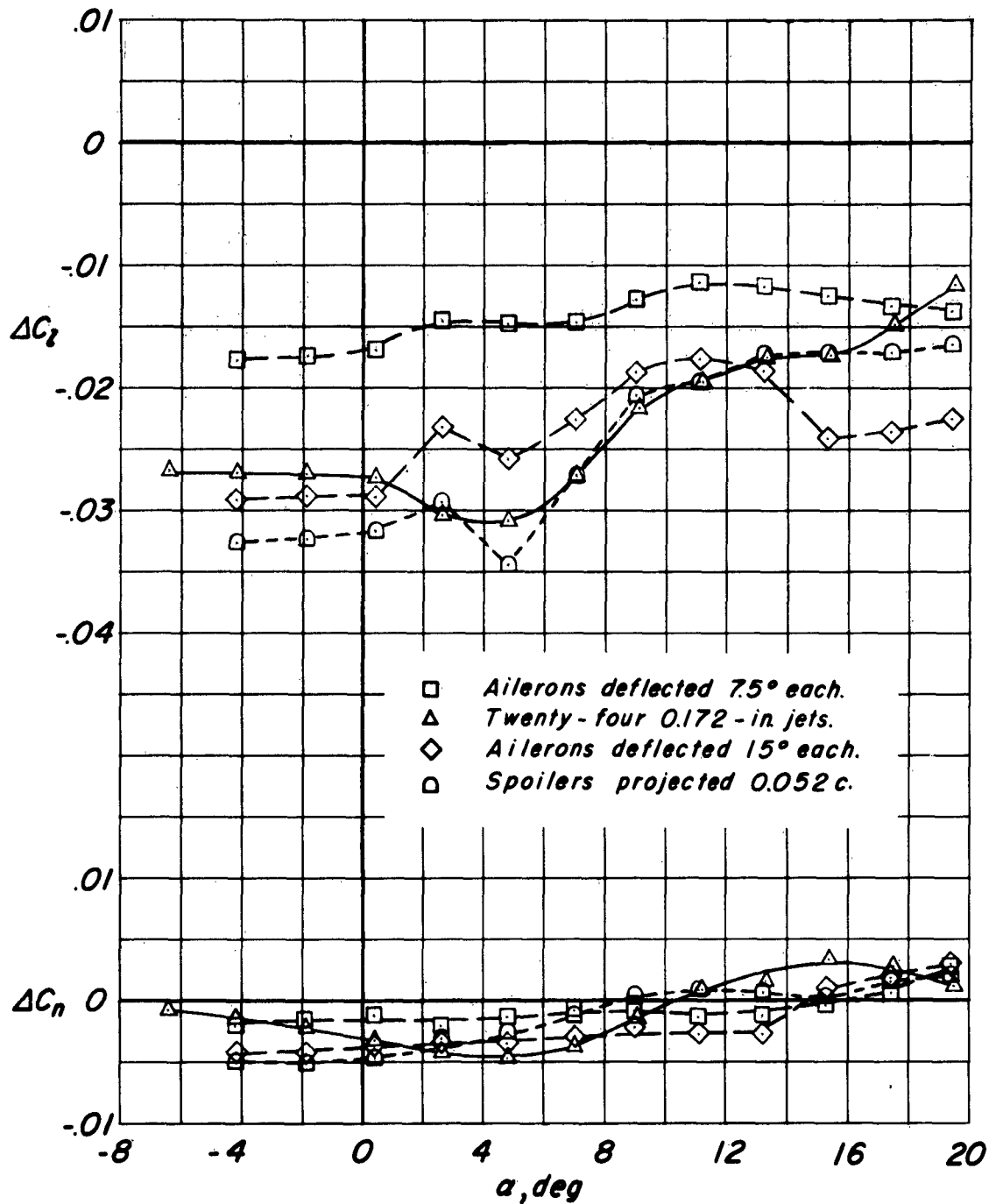
(b) M = 0.80.

Figure 10.- Continued.



(c) M = 0.85.

Figure 10.- Continued.



(d) $M = 0.90$.

Figure 10.- Continued.

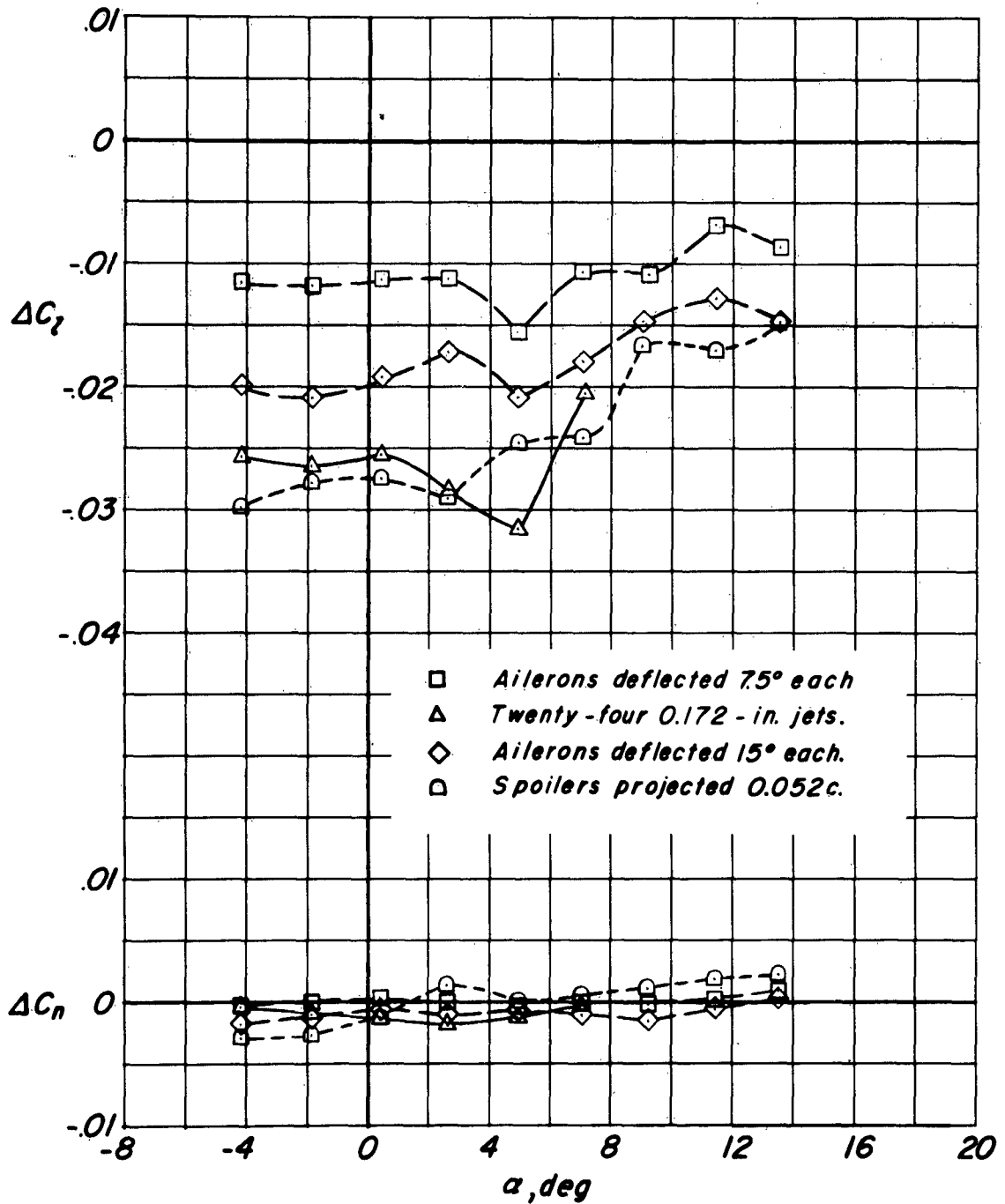
(e) $M = 0.96$.

Figure 10.- Concluded.

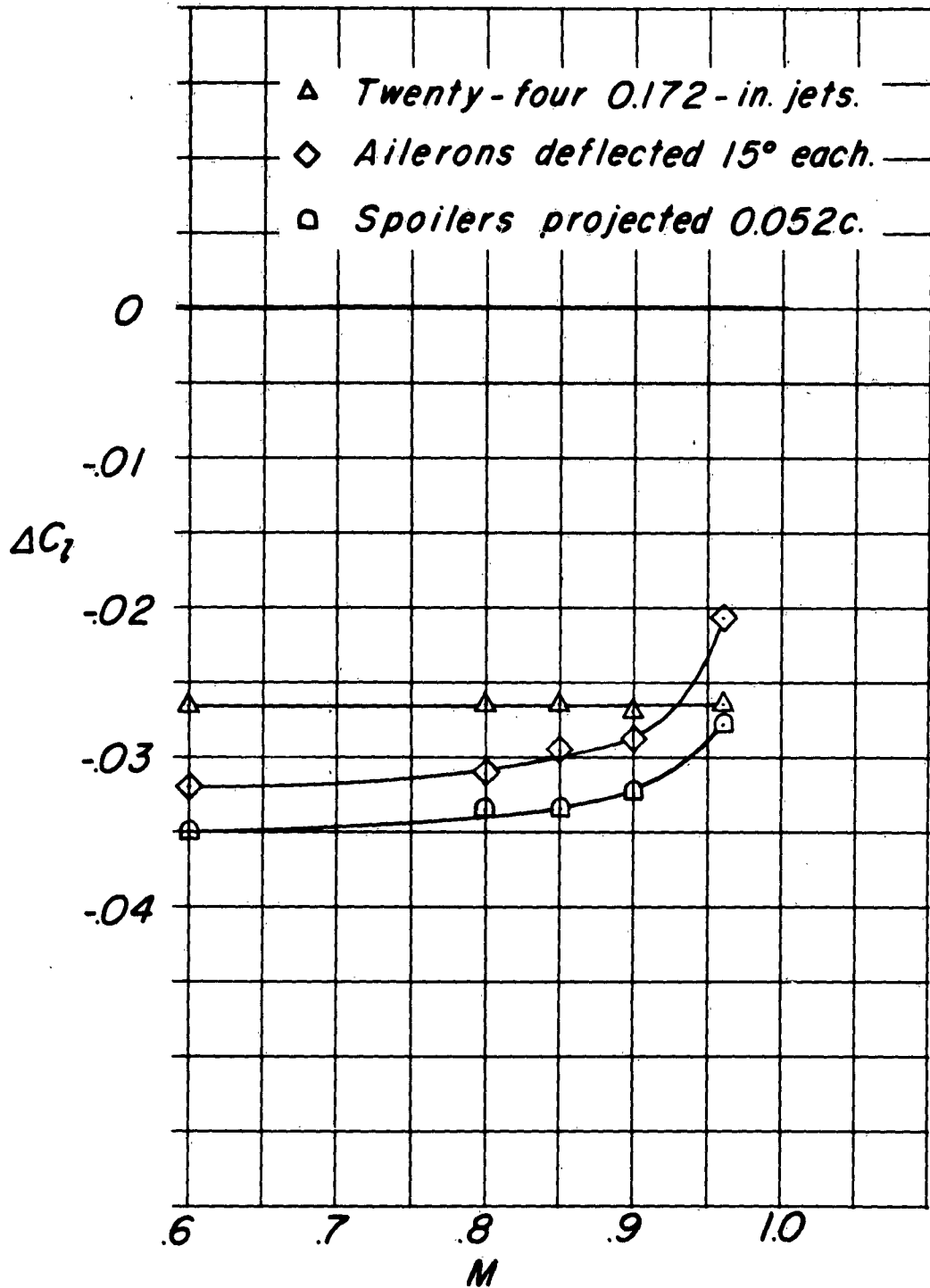
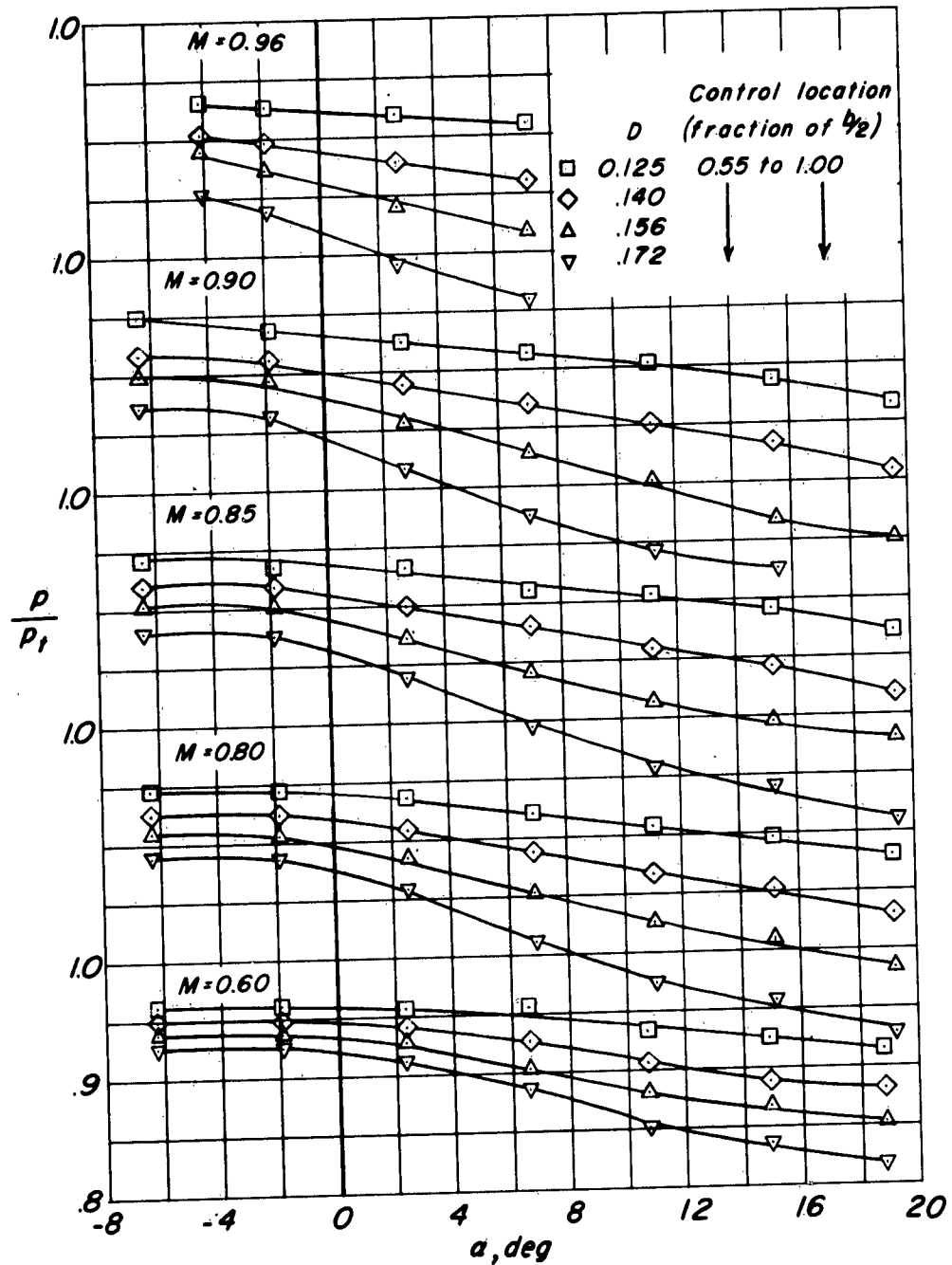
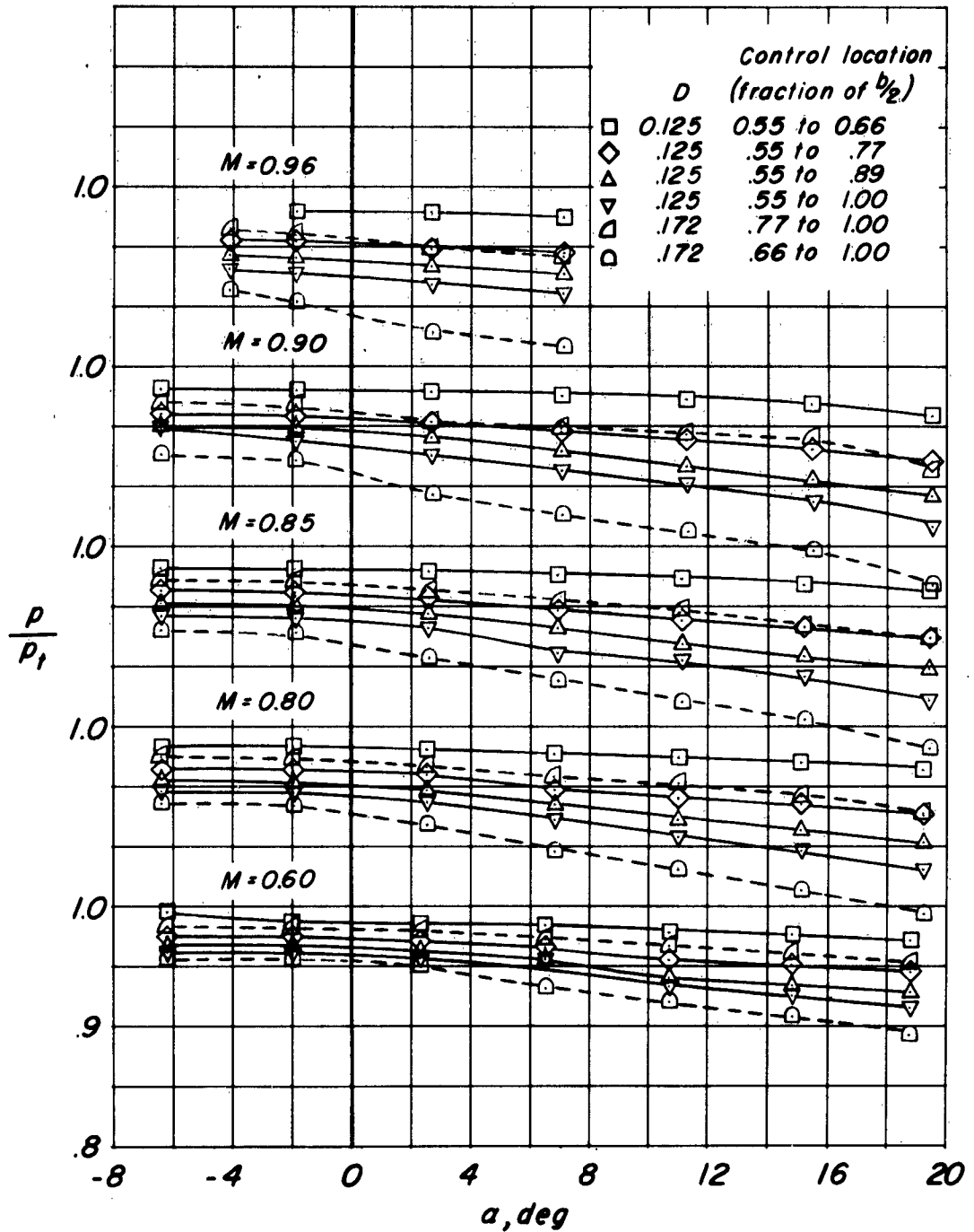


Figure 11.- Variation with Mach number of rolling-moment coefficients produced by jet, spoiler, and aileron controls. $\alpha = -2^\circ$.



(a) Constant span controls.

Figure 12.- Ratios of pressure in large jet-control plenum chamber to tunnel stagnation pressure for various angles of attack and jet diameters.



(b) Variable-span controls.

Figure 12.- Concluded.

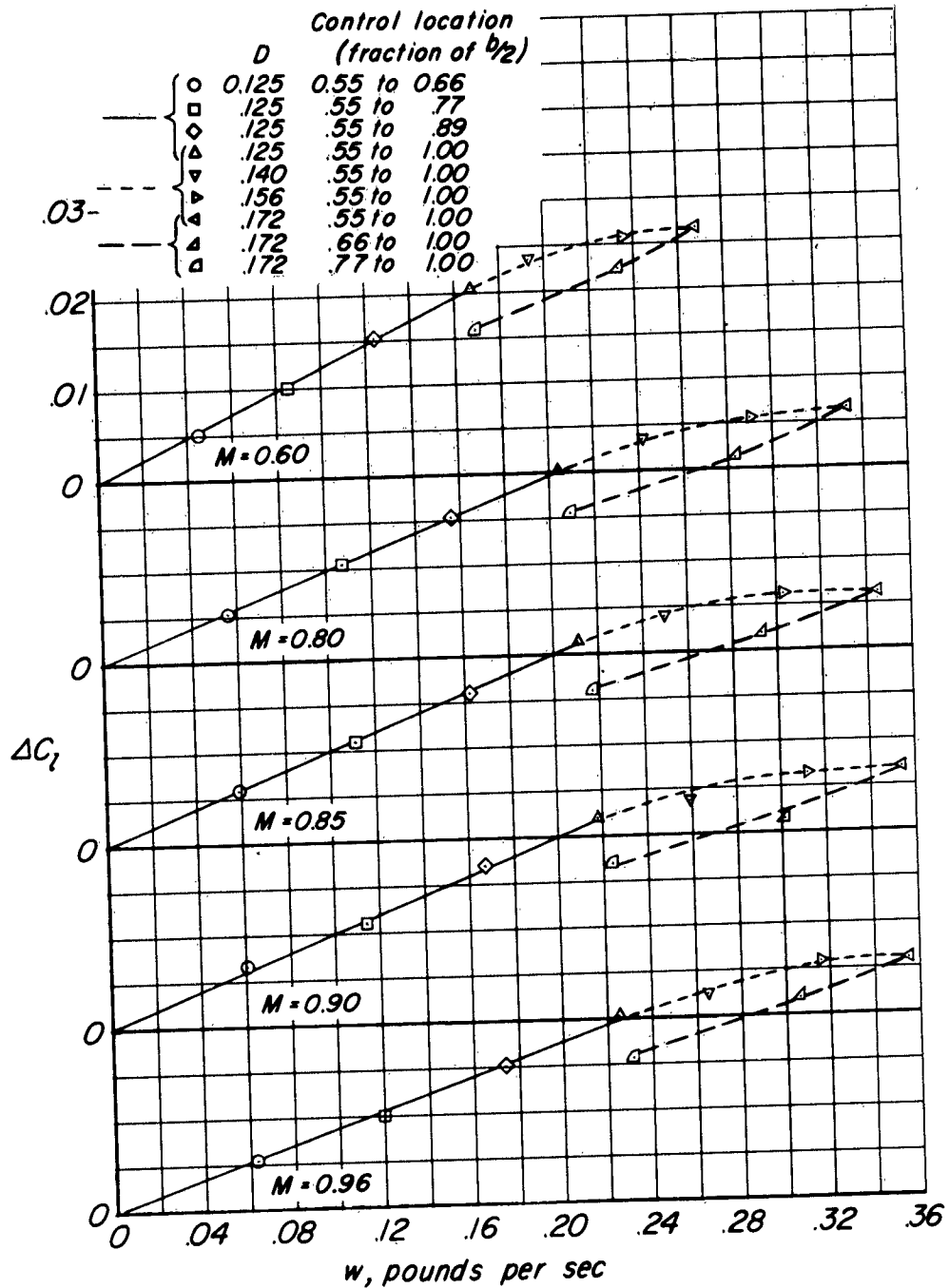


Figure 13.- Variation of rolling-moment coefficient with relative weight flow of air for various jet-control diameters, spans, and locations of controls. Large plenum chamber (w is based on a flow coefficient of unity; correct value is less but unknown). $\alpha = -2^\circ$.

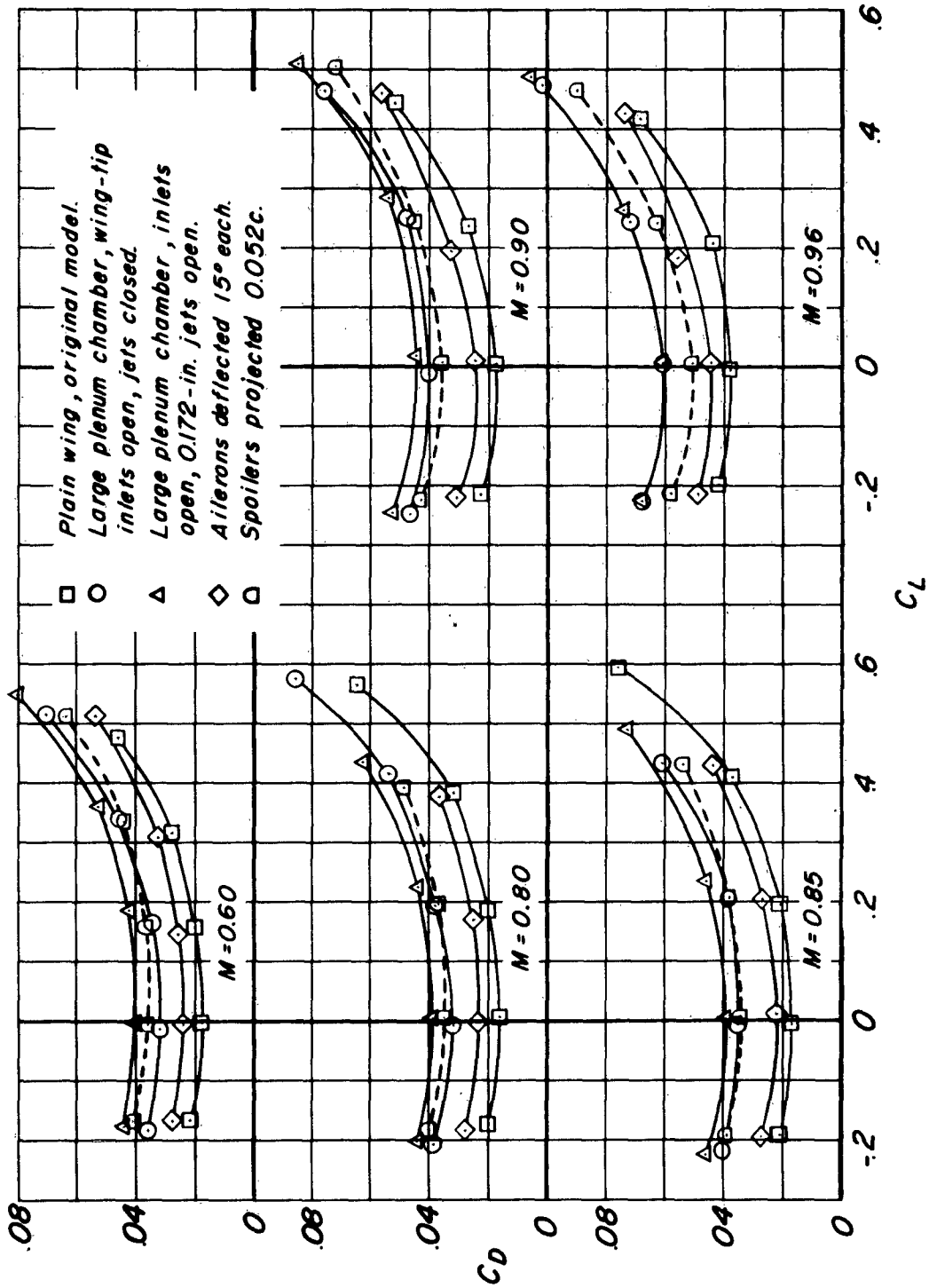


Figure 14.- Comparison of drag coefficients of jet, spoiler, and aileron controls with the plain wing.

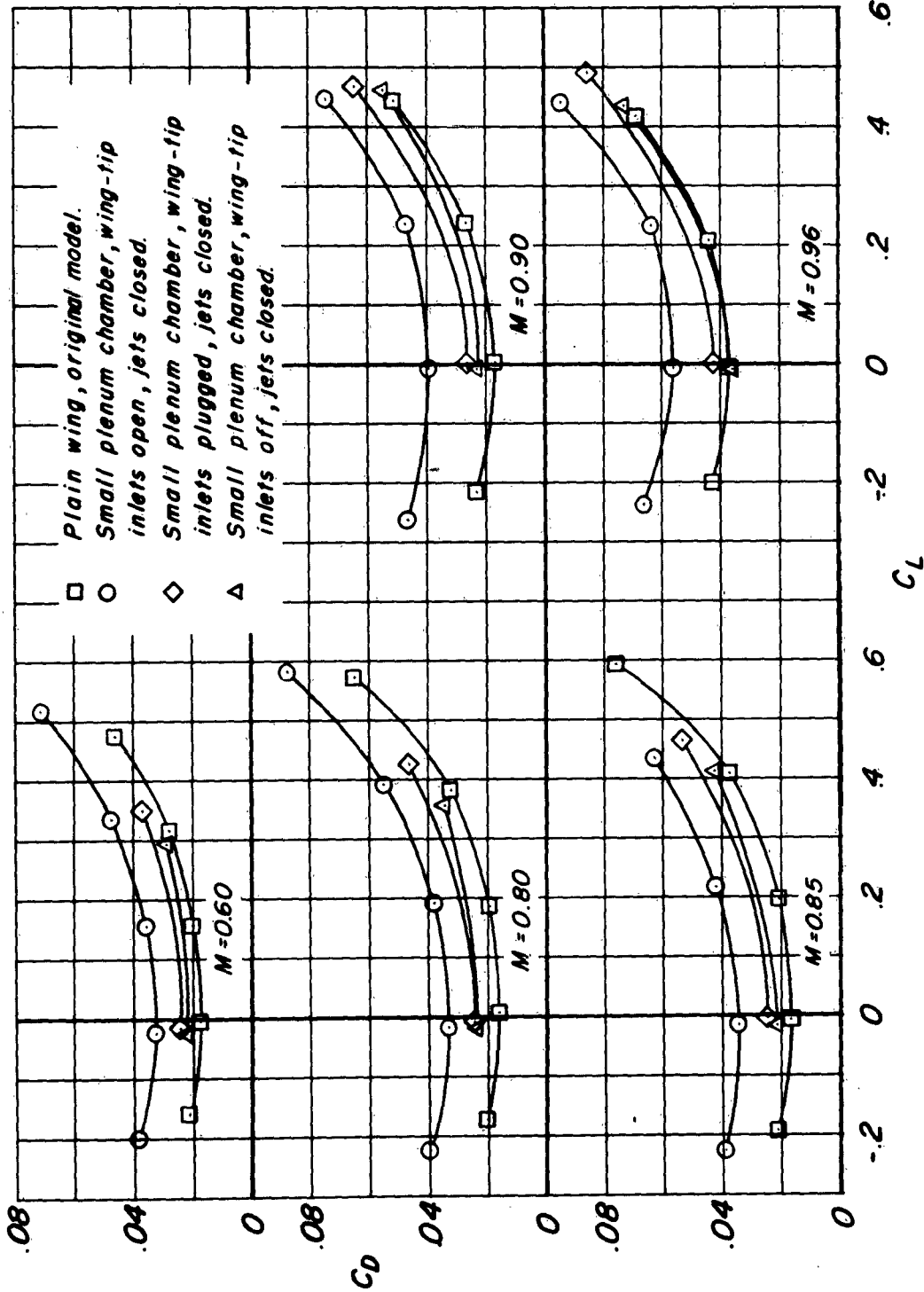


Figure 15.- Effect on the drag coefficients of some modifications to the jet control configuration.